



PCBN INSERTS







Tipped CBN Inserts
Solid CBN Inserts

Overview		B01 - B04
Code		B05 - B06
Tipped CBN Inserts	CC(P)GW/CC(P)MW DC(P)GW/DC(P)MW TP(N)GN/TP(N)MN VNGW/VNMW SPGN/SPMN WCGW(A)/WCMW(A)	C(D)NGA/C(D)NMA TC(P)GW/TC(P)MW VB(C)GW/VB(C)MW SCGW(N)/SCMW(N) SNGA(N)/SNMA(N)
Solid CBN Inserts Overview		B29 - B30
Solid CBN Inserts	CNGN/CNGX RCGX-V/RCGX-Y DNGN TNGN/TNGX	RNGN SNGN/SNGX TPGN WNGN/WNGX
		B07 - B28
		B31 - B38

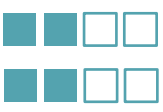
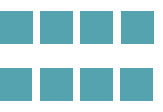
Overview

The main application of CBN inserts is for high-speed machining of hardened steel, powdered metal, super-alloys, and cast iron. Our CBN inserts are optimized and manufactured to provide significantly longer tool life, uniform surface finish, and excellent dimensional control. As a result, the cost of components can decrease significantly, resulting in higher productivity and cost savings in the manufacturing operation.

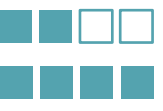
Material Introduction

	Low CBN	High CBN	
Material Characteristics	40 - 70 vol%	70 - 95 vol%	CBN Content
	0.5 - 5 µm	2 - 10 µm	CBN Grain Size
Toughness Behaviour			Strength/Toughness Thermal conductivity Toughness Behaviour also determined by tool edge geometry and severity of machining operation
			
Wear Behaviour			Property/Behaviour in Applications Wear Behaviour is influenced by machining conditions, notably cutting speed and the size of carbides in the workpiece material
			

Behavior in Applications



CBN 300/500

Low content CBN, Excellent thermo-chemical wear resistance

- High speed cut for hardened steel and bearing steel in continuous to light interrupted mode
- High speed cut for ductile cast iron in continuous mode



CBN 450/600

Low content CBN, Excellent thermo-chemical with optimum toughness

- General grade for hardened steels in continuous to interrupted mode
- Hardened alloy steel and tool steel in continuous to light interrupted mode
- Ductile cast iron and gray cast iron to interrupted cutting mode



CBN 750

Medium content CBN, Optimum chemical and abrasion wear resistance

- Soft powdered metal in continuous to light interrupted cutting mode
- Ductile cast iron in continuous to light interrupted cutting mode



CBN 900/950

High content CBN, Excellent fracture toughness and abrasion wear resistance

- Outstanding performance in turning and milling of cast iron
- Hard powder metal in continuous to severe interruption
- Hardened steel and tool steel in interrupted cutting mode
- Turning of tungsten carbide

Machining Parameter Guidelines

Work Material	Hardness	Cutting Speed V(m/min)	Cutting Depth d(mm)	Feed Rate f(mm/rev)	Recommandation
Hardened Steel	>55HRC	80~120	0.3~1.5	0.08~0.2	CBN300/500 CBN900
	<56HRC	80~150	0.5~2.0	0.1~0.25	CBN300/500
Gray Cast Iron	180-230 HB	500~1500	0.1~2.0	0.15~0.4	CBN750,CBN900
Ductile Cast Iron		200~700	0.3~2.0	0.1~0.4	CBN450
Rolls(Chilled Cast Iron)	>55 HRC	80~120	0.3~2.0	0.1~0.3	CBN900
Powdered Metal	<35 HRC	100~300	0.3~2.0	0.1~0.3	CBN500,CBN900
	>35HRC	50~200	0.3~2.0	0.1~0.3	

Edge Preparation

Work Material & Working Mode	chamfer Angle α	Chamfer Weight a(mm)	Blunt Roundness R(mm)
Steel	25°	0.1~0.2	0.01~0.02
Cast Iron	20°	0.1~0.5	<0.01
Interruption Mode	30°	0.2	0.01~0.03

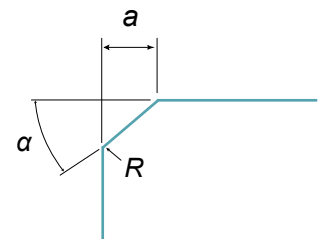

Tips:

- To make sure the maximum strength, it's better to use the inserts with a larger corner radius
- The blade chamfering will avoid the edge not to break during the interrupted cutting
- Don't use the coolant during the continuous cutting

User Case



Work material: Hardened steel, 57-62HRC, $V(m/min)=100$, $f(m/rev)=0.1$, $d(mm)=0.15mm$

One set of inserts can machine over 500 pcs workpieces, better dimensions, and surface roughness control. 10 times working life increased over other material inserts.



Cylinder bore 750~1200m/min

High-speed machining of gray cast iron cylinder bores 750~1200m/min Longer tool life, increased productivity, stable shape and dimensions, and superior cylindricity in mass production.



Face turning of half shaft HRC55-60 20CrNiMoH

$V(m/min)=170$ $f=0.22$ $D(mm)=0.1$ Increased 15% tooling life increased over competitors, at the same working parameter, Greatly reducing the user's cost.



Code

ISO

C	N	M	A	12	04	08	-	1	TP	-	T	010	15	0
1	2	3	4	5	6	7		8	9		10	11	12	13

1
Inserts Shape

A		R	
B		S	
C		T	
D		V	
		W	

2
Clearance Angle

B		N	
C		P	
D			

4
Machining and Fastening Feature

A		N		W	
B		Q		X	Drawing or Precise description of indexable inserts required

3
Tolerances, ISO[MM]

	d	m	s
	A ±0.025	±0.005	±0.025
	C ±0.025	±0.013	±0.025
	E ±0.025	±0.025	±0.025
	F ±0.013	±0.005	±0.025
	G ±0.025	±0.025	±0.130
	H ±0.013	±0.013	±0.025
	J ±0.05~±0.15	±0.005	±0.025
	K ±0.05~±0.15	±0.013	±0.025
	L ±0.05~±0.15	±0.025	±0.025
	M ±0.05~±0.15	±0.08~±0.20	±0.130

5
Insert size

Inner circle diameter	Insert size						
	C	D	R	S	T	V	W
IC mm	Code	Code	Code	Code	Code	Code	Code
3.97	1.2			03	06		03
5					08		
5.56	1.8			07	09		
6		06					
6.35	2	1/4"	06		11	11	04
8			08				05
9.525	3	3/8"	09	11	09	16	16
10							
12							
12.7	4	1/2"	12	15	12	22	22
15.875	5	5/8"	16		15	27	
16							12
19.05	6	3/4"	19		19	33	
20							
25							
25.4	8	1"	25				
31.75	10	1-1/4"					

ANSI



C	N	M	A	4	3	2	-	1	TP	-	T	010	15	0
1	2	3	4	5	6	7		8	9		10	11	12	13





6			
Thickness			
ISO		ANSI	
01	1.59	1	1/16
T1	1.98	1.2	0.75
02	2.38	1.5	3/32
T2	2.78	-	-
03	3.18	2	1/8
T3	3.97	2.5	5/32
04	4.76	3	3/16
05	5.56	3.5	7/32
06	6.36	4	1/4
07	7.94	5	5/16
09	9.52	6	3/8

7			
Corner radius r mm, Inch			
ISO		ANSI	
01	r=0.1	0.1	1/25
02	r=0.2	0	2/25
04	r=0.4	1	1/64
08	r=0.8	2	1/32
12	r=1.2	3	3/64
16	r=1.6	4	1/16
24	r=2.4	6	3/32
32	r=3.2	8	1/8

0 For diameters converted from imperial units to mm
M0 For diameters in metrica units

8	
Number of cutting corners	
1	1 corner
2	2 corners
3	3 corners
4	4 corners
6	6 corners
8	8 corners

9	
Inserts form	
	TP
	FE
	SF

10 ①	
Edge Formation	
E 	Honing
F 	Sharp edge
T 	chamfering
S 	chamfering + Honing

11 ①	
Chamfer width	
010	0.10mm
020	0.20mm
025	0.25mm
030	0.30mm
040	0.40mm
050	0.50mm
070	0.70mm
150	1.50mm
200	2.00mm

12 ①	
Chamfer edge	
10	10°
15	15°
20	20°
25	25°
30	30°
35	35°
45	45°

13 ①	
Blunt roundness	
02	0.002
05	0.005
10	0.01
20	0.02
30	0.03

CCGW/CCMW

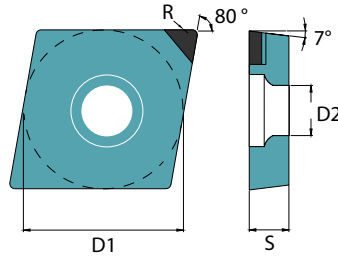
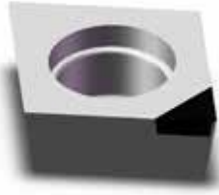

Designation	D1 [MM]	D2 [MM]	S [MM]	R
CCGW060202-1TP	6.35	2.8	2.38	0.2
CCGW060204-1TP				0.4
CCGW060208-1TP				0.8
CCMW060202-1TP	6.35	2.8	2.38	0.2
CCMW060204-1TP				0.4
CCMW060208-1TP				0.8
CCGW09T302-1TP	9.525	4.4	3.97	0.2
CCGW09T304-1TP				0.4
CCGW09T308-1TP				0.8
CCMW09T302-1TP	9.525	4.4	3.97	0.2
CCMW09T304-1TP				0.4
CCMW09T308-1TP				0.8
CCGW120402-1TP	12.7	5.5	4.76	0.2
CCGW120404-1TP				0.4
CCGW120408-1TP				0.8
CCMW120402-1TP	12.7	5.5	4.76	0.2
CCMW120404-1TP				0.4
CCMW120408-1TP				0.8

Designation	D1 [MM]	D2 [MM]	S [MM]	R
CCGW090404-1TP	9.525	3.81	4.76	0.4
CCGW090408-1TP				0.8
CCGW090412-1TP				1.2
CCGW090416-1TP				1.6
CCMW090402-1TP	9.525	3.81	4.76	0.2
CCMW090404-1TP				0.4
CCMW090408-1TP				0.8
CCMW090412-1TP				1.2
CCGW120402-1TP	12.7	5.5	4.76	0.2
CCGW120404-1TP				0.4
CCGW120408-1TP				0.8
CCGW120412-1TP				1.2
CCGW120416-1TP	12.7	5.5	4.76	1.6
CCMW120402-1TP				0.2
CCMW120404-1TP				0.4
CCMW120408-1TP				0.8
CCMW120412-1TP	12.7	5.5	4.76	1.2
CCMW120416-1TP				1.6
CCGW160608-1TP				0.8
CCGW160612-1TP	15.875	6.35	6.35	1.2
CCGW160616-1TP				1.6
CCMW160608-1TP	15.875	6.35	6.35	0.8
CCMW160612-1TP				1.2
CCMW160616-1TP				1.6

Order Note

- Please refer to B 01/02 for CBN inserts Code Key description.
- To place an order, please refer to the Designation code.
- For the item which not on the list pls contact us sales to get the quote.

CCGW/CCMW

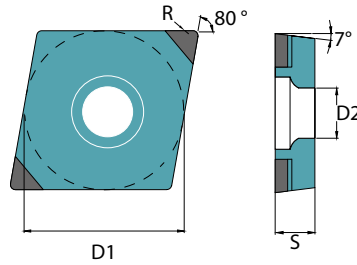

Designation	D1 [MM]	D2 [MM]	S [MM]	R
CCGW060202-2TP	6.35	2.8	2.38	0.2
CCGW060204-2TP				0.4
CCGW060208-2TP				0.8
CCMW060202-2TP	6.35	2.8	2.38	0.2
CCMW060204-2TP				0.4
CCMW060208-2TP				0.8
CCGW09T302-2TP	9.525	4.4	3.97	0.2
CCGW09T304-2TP				0.4
CCGW09T308-2TP				0.8
CCMW09T302-2TP	9.525	4.4	3.97	0.2
CCMW09T304-2TP				0.4
CCMW09T308-2TP				0.8
CCGW120402-2TP	12.7	5.5	4.76	0.2
CCGW120404-2TP				0.4
CCGW120408-2TP				0.8
CCMW120402-2TP	12.7	5.5	4.76	0.2
CCMW120404-2TP				0.4
CCMW120408-2TP				0.8

Designation	D1 [MM]	D2 [MM]	S [MM]	R			
CCGW090404-2TP	9.525	3.81	4.76	0.4			
CCGW090408-2TP				0.8			
CCGW090412-2TP				1.2			
CCGW090416-2TP				1.6			
CCMW090402-2TP	9.525	3.81	4.76	0.2			
CCMW090404-2TP				0.4			
CCMW090408-2TP				0.8			
CCMW090412-2TP				1.2			
CCGW120402-2TP	12.7	5.5	4.76	0.2			
CCGW120404-2TP				0.4			
CCGW120408-2TP				0.8			
CCGW120412-2TP				1.2			
CCGW120416-2TP	12.7	5.5	4.76	1.6			
CCMW120402-2TP				0.2			
CCMW120404-2TP				0.4			
CCMW120408-2TP				0.8			
CCMW120412-2TP	12.7	5.5	4.76	1.2			
CCMW120416-2TP				1.6			
CCGW160608-2TP				15.875	6.35	6.35	0.8
CCGW160612-2TP							1.2
CCGW160616-2TP	1.6						
CCMW160608-2TP	15.875	6.35	6.35	0.8			
CCMW160612-2TP				1.2			
CCMW160616-2TP				1.6			

Order Note

- Please refer to B 01/02 for CBN inserts Code Key description.
- To place an order, please refer to the Designation code.
- For the item which not on the list pls contact us sales to get the quote.

CPGW/CPMW

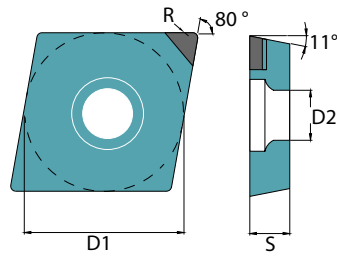

Designation	D1 [MM]	D2 [MM]	S [MM]	R
CPGW060204-1TP	6.35	2.8	2.38	0.4
CPGW060208-1TP				0.8
CPMW060202-1TP	6.35	2.8	2.38	0.2
CPMW060204-1TP				0.4
CPMW060208-1TP				0.8
CPGW090302-1TP	9.525	4.4	3.18	0.2
CPGW090304-1TP				0.4
CPGW090308-1TP				0.8

Designation	D1 [MM]	D2 [MM]	S [MM]	R
CPMW090304-1TP	9.525	4.4	3.18	0.4
CPMW090308-1TP				0.8
CPGW120402-1TP	12.7	5.5	4.76	0.2
CPGW120404-1TP				0.4
CPGW120408-1TP				0.8
CPMW120402-1TP	12.7	5.5	4.76	0.2
CPMW120404-1TP				0.4
CPMW120408-1TP				0.8

CPGW/CPMW

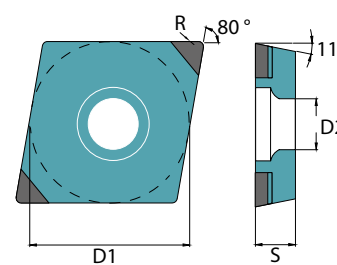
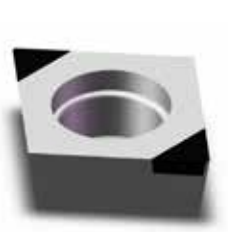

Designation	D1 [MM]	D2 [MM]	S [MM]	R
CPGW060204-2TP	6.35	2.8	2.38	0.4
CPGW060208-2TP				0.8
CPMW060202-2TP	6.35	2.8	2.38	0.2
CPMW060204-2TP				0.4
CPMW060208-2TP				0.8
CPGW090302-2TP	9.525	4.4	3.18	0.2
CPGW090304-2TP				0.4
CPGW090308-2TP				0.8

Designation	D1 [MM]	D2 [MM]	S [MM]	R
CPMW090304-2TP	9.525	4.4	3.18	0.4
CPMW090308-2TP				0.8
CPGW120402-2TP	12.7	5.5	4.76	0.2
CPGW120404-2TP				0.4
CPGW120408-2TP				0.8
CPMW120402-2TP	12.7	5.5	4.76	0.2
CPMW120404-2TP				0.4
CPMW120408-2TP				0.8

Order Note

- Please refer to B 01/02 for CBN inserts Code Key description.
- To place an order, please refer to the Designation code.
- For the item which not on the list pls contact us sales to get the quote.

CNGA/CNMA

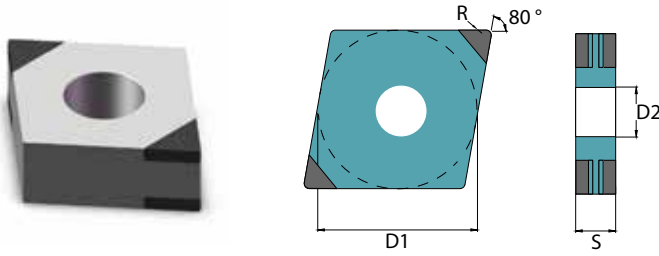

Designation	D1 [MM]	D2 [MM]	S [MM]	R
CNGA090304-4TP	9.525	3.81	3.18	0.4
CNGA090308-4TP				0.8
CNGA090312-4TP				1.2
CNGA090316-4TP				1.6
CNMA090302-4TP	9.525	3.81	3.18	0.2
CNMA090304-4TP				0.4
CNMA090308-4TP				0.8
CNMA090312-4TP				1.2
CNGA160608-4TP	15.875	6.35	6.35	0.8
CNGA160612-4TP				1.2
CNGA160616-4TP				1.6
CNMA160608-4TP	15.875	6.35	6.35	0.8
CNMA160612-4TP				1.2
CNMA160616-4TP				1.6

Designation	D1 [MM]	D2 [MM]	S [MM]	R
CNGA120402-4TP	12.7	5.16	4.76	0.2
CNGA120404-4TP				0.4
CNGA120408-4TP				0.8
CNGA120412-4TP				1.2
CNGA120416-4TP				1.6
CNMA120402-4TP				12.7
CNMA120404-4TP	0.4			
CNMA120408-4TP	0.8			
CNMA120412-4TP	1.2			
CNMA120416-4TP	1.6			

Order Note

- Please refer to B 01/02 for CBN inserts Code Key description.
- To place an order, please refer to the Designation code.
- For the item which not on the list pls contact us sales to get the quote.

CNGA/CNMA

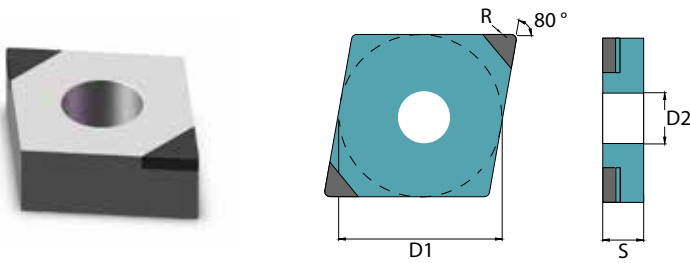

Designation	D1 [MM]	D2 [MM]	S [MM]	R
CNGA090304-2TP	9.525	3.81	3.18	0.4
CNGA090308-2TP				0.8
CNGA090312-2TP				1.2
CNGA090316-2TP				1.6
CNMA090302-2TP	9.525	3.81	3.18	0.2
CNMA090304-2TP				0.4
CNMA090308-2TP				0.8
CNMA090312-2TP				1.2
CNGA160608-2TP	15.875	6.35	6.35	0.8
CNGA160612-2TP				1.2
CNGA160616-2TP				1.6
CNMA160608-2TP	15.875	6.35	6.35	0.8
CNMA160612-2TP				1.2
CNMA160616-2TP				1.6

Designation	D1 [MM]	D2 [MM]	S [MM]	R
CNGA120402-2TP	12.7	5.16	4.76	0.2
CNGA120404-2TP				0.4
CNGA120408-2TP				0.8
CNGA120412-2TP				1.2
CNGA120416-2TP				1.6
CNMA120402-2TP				12.7
CNMA120404-2TP	0.4			
CNMA120408-2TP	0.8			
CNMA120412-2TP	1.2			
CNMA120416-2TP	1.6			

CNGA/CNMA-FULL EDGE

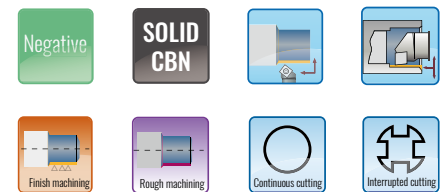
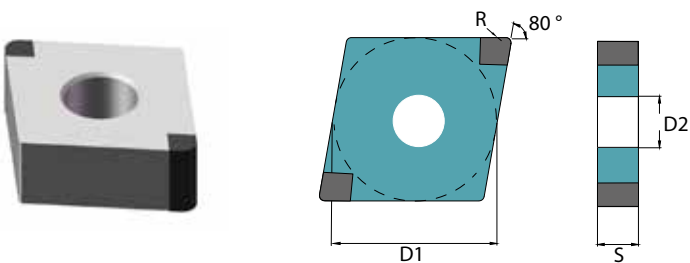

Designation	D1 [MM]	D2 [MM]	S [MM]	R
CNGA120404-2FE	12.7	5.16	4.76	0.4
CNGA120408-2FE				0.8
CNGA120412-2FE				1.2
CNGA120416-2FE				1.6

Order Note

- Please refer to B 01/02 for CBN inserts Code Key description.
- To place an order, please refer to the Designation code.
- For the item which not on the list pls contact us sales to get the quote.

DCGW/DCMW

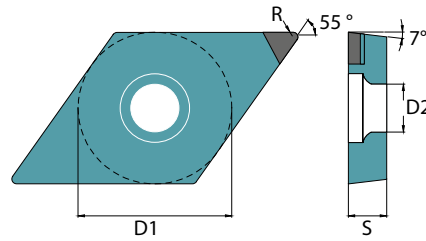
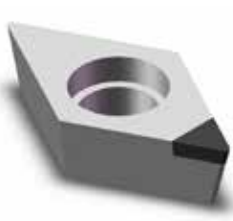

Designation	D1 [MM]	D2 [MM]	S [MM]	R
DCGW070202-1TP	6.35	2.8	2.38	0.2
DCGW070204-1TP				0.4
DCGW070208-1TP				0.8
DCMW070202-1TP	6.35	2.8	2.38	0.2
DCMW070204-1TP				0.4
DCMW070208-1TP				0.8

Designation	D1 [MM]	D2 [MM]	S [MM]	R
DCGW11T304-1TP	9.525	4.4	3.97	0.4
DCGW11T308-1TP				0.8
DCGW11T312-1TP				1.2
DCMW11T304-1TP	9.525	4.4	3.97	0.4
DCMW11T308-1TP				0.8
DCMW11T312-1TP				1.2

DPGW/DPMW

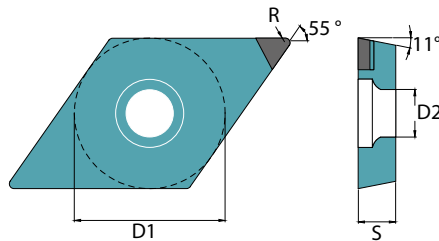
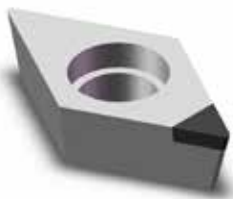

Designation	D1 [MM]	D2 [MM]	S [MM]	R
DPGT070202-1TP	6.35	2.8	2.38	0.2
DPGT070204-1TP				0.4
DPGT070208-1TP				0.8
DPMT070202-1TP	6.35	2.8	2.38	0.2
DPMT070204-1TP				0.4
DPMT070208-1TP				0.8

Designation	D1 [MM]	D2 [MM]	S [MM]	R
DPGT11T304-1TP	9.525	4.4	3.97	0.4
DPGT11T308-1TP				0.8
DPGT11T312-1TP				1.2
DPMT11T304-1TP	9.525	4.4	3.97	0.4
DPMT11T308-1TP				0.8
DPMT11T312-1TP				1.2

Order Note

- Please refer to B 01/02 for CBN inserts Code Key description.
- To place an order, please refer to the Designation code.
- For the item which not on the list pls contact us sales to get the quote.

DNGA/DNMA

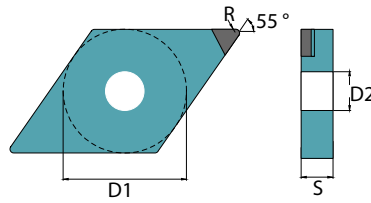
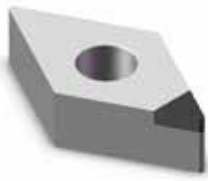

Designation	D1 [MM]	D2 [MM]	S [MM]	R
DNGA150604-1TP	12.7	5.16	6.35	0.4
DNGA150608-1TP				0.8
DNGA150612-1TP				1.2
DNGA150616-1TP				1.6
DNMA150604-1TP	12.7	5.16	6.35	0.4
DNMA150608-1TP				0.8
DNMA150612-1TP				1.2
DNMA150616-1TP				1.6

Designation	D1 [MM]	D2 [MM]	S [MM]	R
DNGA110404-1TP	9.525	3.81	4.76	0.4
DNGA110408-1TP				0.8
DNGA110412-1TP				1.2
DNMA110404-1TP				0.4
DNMA110408-1TP	9.525	3.81	4.76	0.8
DNMA110412-1TP				1.2

DNGA/DNMA

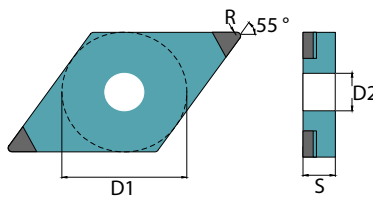
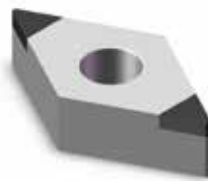

Designation	D1 [MM]	D2 [MM]	S [MM]	R
DNGA150604-2TP	12.7	5.16	6.35	0.4
DNGA150608-2TP				0.8
DNGA150612-2TP				1.2
DNGA150616-2TP				1.6
DNMA150604-2TP	12.7	5.16	6.35	0.4
DNMA150608-2TP				0.8
DNMA150612-2TP				1.2
DNMA150616-2TP				1.6

Designation	D1 [MM]	D2 [MM]	S [MM]	R
DNGA110404-2TP	9.525	3.81	4.76	0.4
DNGA110408-2TP				0.8
DNGA110412-2TP				1.2
DNMA110404-2TP	9.525	3.81	4.76	0.4
DNMA110408-2TP				0.8
DNMA110412-2TP				1.2

Order Note

- Please refer to B 01/02 for CBN inserts Code Key description.
- To place an order, please refer to the Designation code.
- For the item which not on the list pls contact us sales to get the quote.

DNGA-FULL EDGE

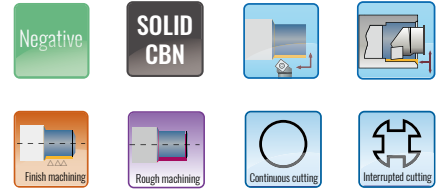
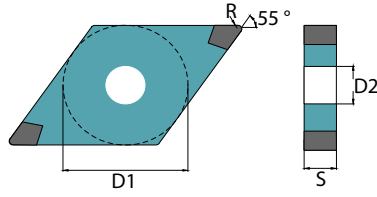
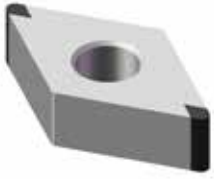

Designation	D1 [MM]	D2 [MM]	S [MM]	R
DNGA150404-2FE	12.7	5.16	4.76	0.4
DNGA150408-2FE				0.8
DNGA150412-2FE				1.2
DNGA150416-2FE				1.6
DNGA150604-2FE	12.7	5.16	6.35	0.4
DNGA150608-2FE				0.8
DNGA150612-2FE				1.2
DNGA150616-2FE				1.6

Order Note

- Please refer to B 01/02 for CBN inserts Code Key description.
- To place an order, please refer to the Designation code.
- For the item which not on the list pls contact us sales to get the quote.

TCGW/TCMW

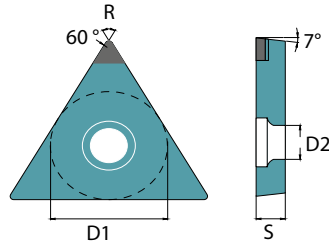
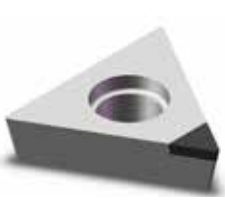

Designation	D1 [MM]	D2 [MM]	S [MM]	R
TCGW090202-1TP	5.56	2.5	2.38	0.2
TCGW090204-1TP				0.4
TCGW090208-1TP				0.8
TCMW090202-1TP	5.56	2.5	2.38	0.2
TCMW090204-1TP				0.4
TCMW090208-1TP				0.8

Designation	D1 [MM]	D2 [MM]	S [MM]	R
TCGW110202-1TP	6.35	2.8	2.38	0.2
TCGW110204-1TP				0.4
TCGW110208-1TP				0.8
TCMW110202-1TP	6.35	2.8	2.38	0.2
TCMW110204-1TP				0.4
TCMW110208-1TP				0.8

TCGW/TCMW

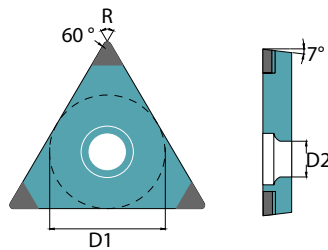
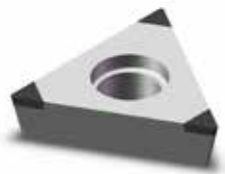

Designation	D1 [MM]	D2 [MM]	S [MM]	R
TCGW090202-3TP	5.56	2.5	2.38	0.2
TCGW090204-3TP				0.4
TCGW090208-3TP				0.8
TCMW090202-3TP	5.56	2.5	2.38	0.2
TCMW090204-3TP				0.4
TCMW090208-3TP				0.8

Designation	D1 [MM]	D2 [MM]	S [MM]	R
TCGW110202-3TP	6.35	2.8	2.38	0.2
TCGW110204-3TP				0.4
TCGW110208-3TP				0.8
TCMW110202-3TP	6.35	2.8	2.38	0.2
TCMW110204-3TP				0.4
TCMW110208-3TP				0.8

Order Note

- Please refer to B 01/02 for CBN inserts Code Key description.
- To place an order, please refer to the Designation code.
- For the item which not on the list pls contact us sales to get the quote.

TPGN/TPMN

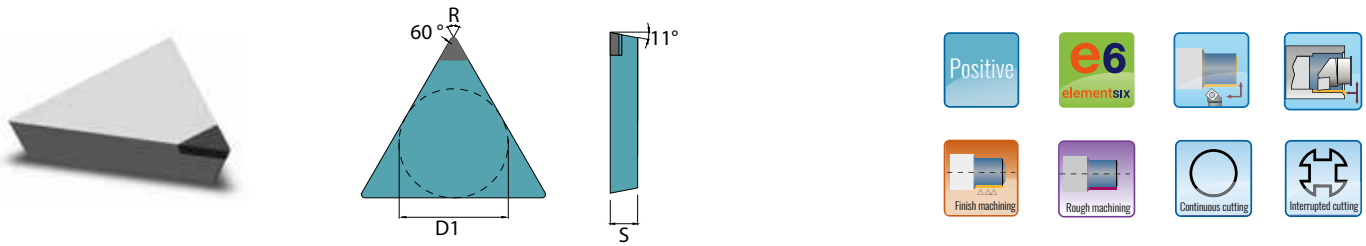

Designation	D1 [MM]	D2 [MM]	S [MM]	R
TPGN110304-1TP	6.35	-	3.18	0.4
TPGN110308-1TP				0.8
TPMN110304-1TP	6.35	-	3.18	0.4
TPMN110308-1TP				0.8
TPGN160304-1TP	9.525	-	3.18	0.4
TPGN160308-1TP				0.8
TPMN160304-1TP	9.525	-	3.18	0.4
TPMN160308-1TP				0.8

TPGN/TPMN

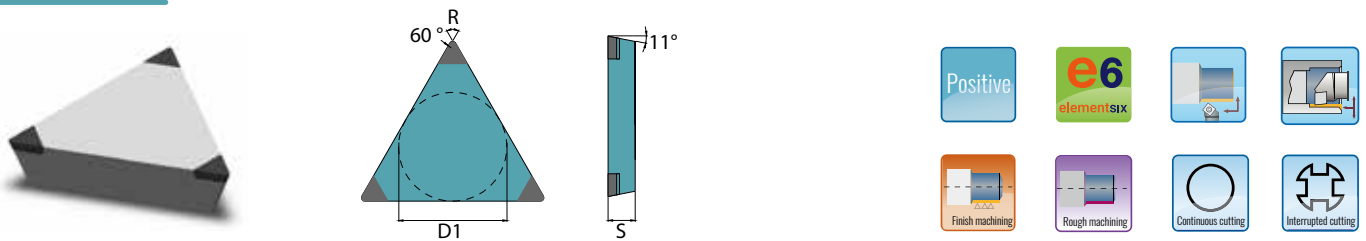

Designation	D1 [MM]	D2 [MM]	S [MM]	R
TPGN110304-3TP	6.35	-	3.18	0.4
TPGN110308-3TP				0.8
TPMN110304-3TP	6.35	-	3.18	0.4
TPMN110308-3TP				0.8
TPGN160304-3TP	9.525	-	3.18	0.4
TPGN160308-3TP				0.8
TPMN160304-3TP	9.525	-	3.18	0.4
TPMN160308-3TP				0.8

Order Note

- Please refer to B 01/02 for CBN inserts Code Key description.
- To place an order, please refer to the Designation code.
- For the item which not on the list pls contact us sales to get the quote.

TPGW/TPMW

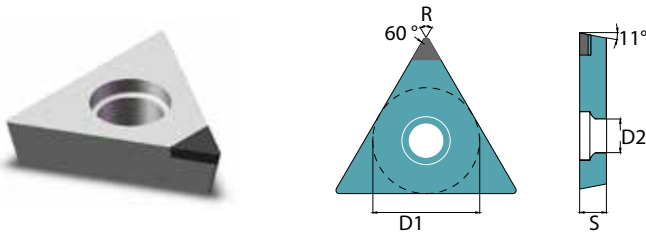

Designation	D1 [MM]	D2 [MM]	S [MM]	R
TPGW090202-1TP	5.56	2.9	2.38	0.2
TPGW090204-1TP				0.4
TPGW090208-1TP				0.8
TPMW090204-1TP	5.56	2.9	2.38	0.4
TPMW090208-1TP				0.8
TPGW110304-1TP	6.35	3.4	3.18	0.4
TPGW110308-1TP				0.8

Designation	D1 [MM]	D2 [MM]	S [MM]	R
TPMW110302-1TP	6.35	3.4	3.18	0.2
TPMW110304-1TP				0.4
TPMW110308-1TP				0.8
TPGW160304-1TP	9.525	4.4	3.18	0.4
TPGW160308-1TP				0.8
TPMW160304-1TP	9.525	4.4	3.18	0.4
TPMW160308-1TP				0.8

TPGW/TPMW

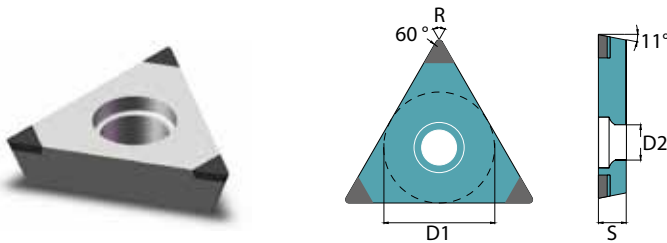

Designation	D1 [MM]	D2 [MM]	S [MM]	R
TPGW090202-3TP	5.56	2.9	2.38	0.2
TPGW090204-3TP				0.4
TPGW090208-3TP				0.8
TPMW090204-3TP	5.56	2.9	2.38	0.4
TPMW090208-3TP				0.8
TPGW110304-3TP	6.35	3.4	3.18	0.4
TPGW110308-3TP				0.8

Designation	D1 [MM]	D2 [MM]	S [MM]	R
TPMW110302-3TP	6.35	3.4	3.18	0.2
TPMW110304-3TP				0.4
TPMW110308-3TP				0.8
TPGW160304-3TP	9.525	4.4	3.18	0.4
TPGW160308-3TP				0.8
TPMW160304-3TP	9.525	4.4	3.18	0.4
TPMW160308-3TP				0.8

Order Note

- Please refer to B 01/02 for CBN inserts Code Key description.
- To place an order, please refer to the Designation code.
- For the item which not on the list pls contact us sales to get the quote.

TNGA/TNWA

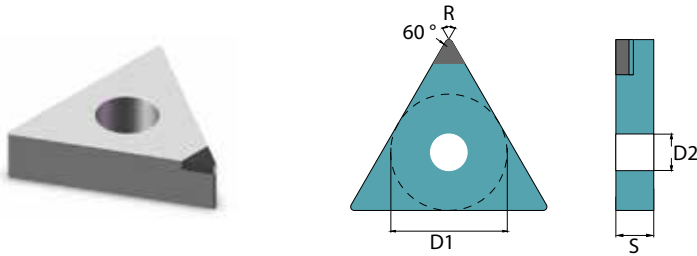

Designation	D1 [MM]	D2 [MM]	S [MM]	R
TNGA160404-1TP	9.525	3.81	4.76	0.4
TNGA160408-1TP				0.8
TNGA160412-1TP				1.2
TNWA160404-1TP	9.525	3.81	4.76	0.4
TNWA160408-1TP				0.8
TNWA160412-1TP				1.2

TNGA/TNWA

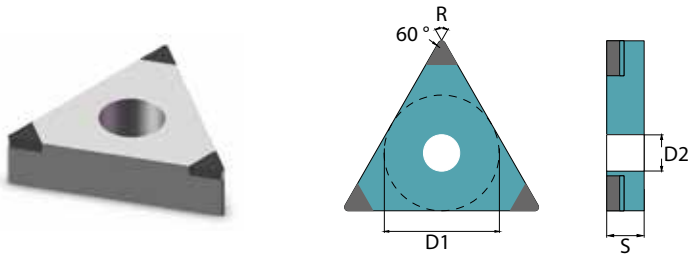

Designation	D1 [MM]	D2 [MM]	S [MM]	R
TNGA160404-3TP	9.525	3.81	4.76	0.4
TNGA160408-3TP				0.8
TNGA160412-3TP				1.2
TNWA160404-3TP	9.525	3.81	4.76	0.4
TNWA160408-3TP				0.8
TNWA160412-3TP				1.2

Order Note

- Please refer to B 01/02 for CBN inserts Code Key description.
- To place an order, please refer to the Designation code.
- For the item which not on the list pls contact us sales to get the quote.

TNGA-FULL EDGE

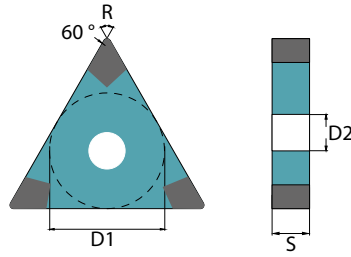
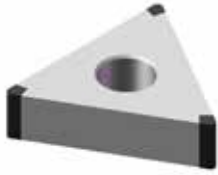

Designation	D1 [MM]	D2 [MM]	S [MM]	R
TNGA160404-3FE	9.525	3.81	4.76	0.4
TNGA160408-3FE				0.8
TNGA160412-3FE				1.2
TNGA220404-3FE	12.7	5.16	4.76	0.4
TNGA220408-3FE				0.8
TNGA220412-3FE				1.2

Order Note

- Please refer to B 01/02 for CBN inserts Code Key description.
- To place an order, please refer to the Designation code.
- For the item which not on the list pls contact us sales to get the quote.

VBGW/VBMW

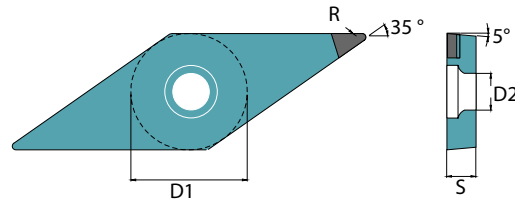
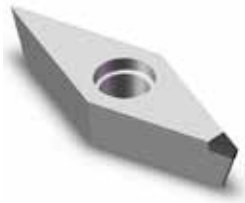

Designation	D1 [MM]	D2 [MM]	S [MM]	R
VBGW160402-1TP	9.525	4.4	4.76	0.2
VBGW160404-1TP				0.4
VBGW160408-1TP				0.8
VBGW160412-1TP				1.2
VBMW160402-1TP	9.525	4.4	4.76	0.2
VBMW160404-1TP				0.4
VBMW160408-1TP				0.8
VBMW160412-1TP				1.2

VBGW/VBMW

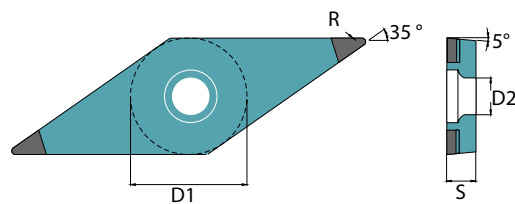
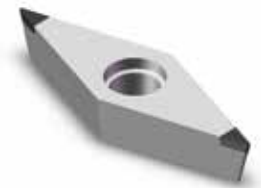

Designation	D1 [MM]	D2 [MM]	S [MM]	R
VBGW160402-2TP	9.525	4.4	4.76	0.2
VBGW160404-2TP				0.4
VBGW160408-2TP				0.8
VBGW160412-2TP				1.2
VBMW160402-2TP	9.525	4.4	4.76	0.2
VBMW160404-2TP				0.4
VBMW160408-2TP				0.8
VBMW160412-2TP				1.2

Order Note

- Please refer to B 01/02 for CBN inserts Code Key description.
- To place an order, please refer to the Designation code.
- For the item which not on the list pls contact us sales to get the quote.

VCGW/VCMW

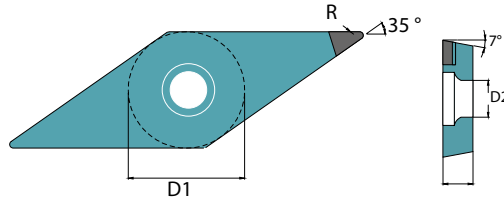

Designation	D1 [MM]	D2 [MM]	S [MM]	R
VCGW160402-1TP	9.525	4.4	4.76	0.2
VCGW160404-1TP				0.4
VCGW160408-1TP				0.8
VCMW160402-1TP	9.525	4.4	4.76	0.2
VCMW160404-1TP				0.4
VCMW160408-1TP				0.8

VCGW/VCMW

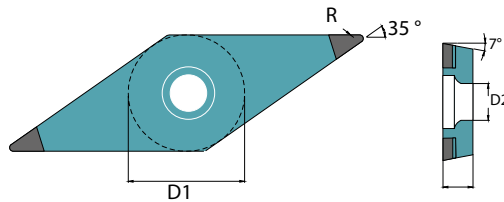

Designation	D1 [MM]	D2 [MM]	S [MM]	R
VCGW160402-2TP	9.525	4.4	4.76	0.2
VCGW160404-2TP				0.4
VCGW160408-2TP				0.8
VCMW160402-2TP	9.525	4.4	4.76	0.2
VCMW160404-2TP				0.4
VCMW160408-2TP				0.8

Order Note

- Please refer to B 01/02 for CBN inserts Code Key description.
- To place an order, please refer to the Designation code.
- For the item which not on the list pls contact us sales to get the quote.

VNGW/VNMW

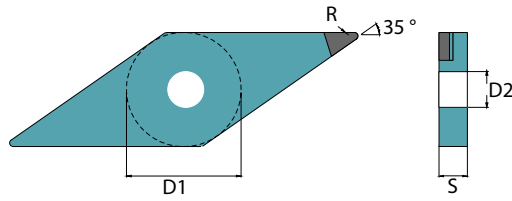
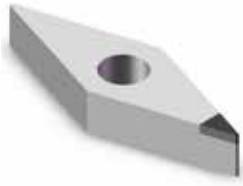

Designation	D1 [MM]	D2 [MM]	S [MM]	R
VNGW160402-1TP	9.525	3.81	4.76	0.2
VNGW160404-1TP				0.4
VNGW160408-1TP				0.8
VNGW160412-1TP				1.2
VNMW160402-1TP	9.525	3.81	4.76	0.2
VNMW160404-1TP				0.4
VNMW160408-1TP				0.8
VNMW160412-1TP				1.2

VNGW/VNMW

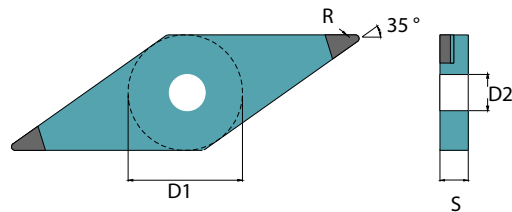
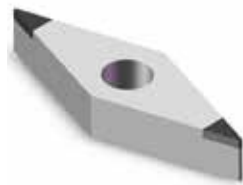

Designation	D1 [MM]	D2 [MM]	S [MM]	R
VNGW160402-2TP	9.525	3.81	4.76	0.2
VNGW160404-2TP				0.4
VNGW160408-2TP				0.8
VNGW160412-2TP				1.2
VNMW160402-2TP	9.525	3.81	4.76	0.2
VNMW160404-2TP				0.4
VNMW160408-2TP				0.8
VNMW160412-2TP				1.2

Order Note

- Please refer to B 01/02 for CBN inserts Code Key description.
- To place an order, please refer to the Designation code.
- For the item which not on the list pls contact us sales to get the quote.

SCGW/SCMW

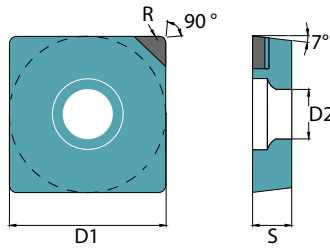
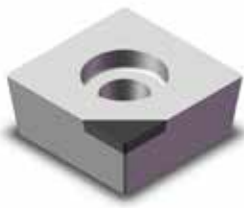

Designation	D1 [MM]	D2 [MM]	S [MM]	R
SCGW09T304-1TP	9.525	4.4	3.97	0.4
SCGW09T308-1TP				0.8
SCGW09T312-1TP				1.2
SCMW09T304-1TP	9.525	4.4	3.97	0.4
SCMW09T308-1TP				0.8
SCMW09T312-1TP				1.2

Designation	D1 [MM]	D2 [MM]	S [MM]	R
SCGW120404-1TP	12.7	5.5	4.76	0.4
SCGW120408-1TP				0.8
SCGW120412-1TP				1.2
SCMW120404-1TP	12.7	5.5	4.76	0.4
SCMW120408-1TP				0.8
SCMW120412-1TP				1.2

SCGW/SCMW

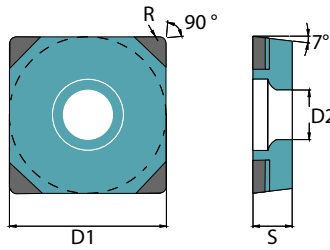
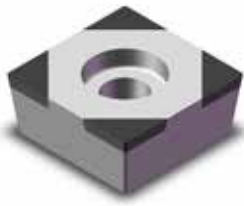

Designation	D1 [MM]	D2 [MM]	S [MM]	R
SCGW09T304-4TP	9.525	4.4	3.97	0.4
SCGW09T308-4TP				0.8
SCGW09T312-4TP				1.2
SCMW09T304-4TP	9.525	4.4	3.97	0.4
SCMW09T308-4TP				0.8
SCMW09T312-4TP				1.2

Designation	D1 [MM]	D2 [MM]	S [MM]	R
SCGW120404-4TP	12.7	5.5	4.76	0.4
SCGW120408-4TP				0.8
SCGW120412-4TP				1.2
SCMW120404-4TP	12.7	5.5	4.76	0.4
SCMW120408-4TP				0.8
SCMW120412-4TP				1.2

Order Note

- Please refer to B 01/02 for CBN inserts Code Key description.
- To place an order, please refer to the Designation code.
- For the item which not on the list pls contact us sales to get the quote.

SPGN/SPMN

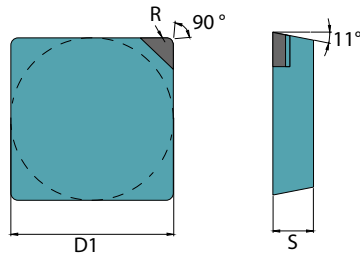

Designation	D1 [MM]	D2 [MM]	S [MM]	R
SPGN120404-1TP	12.7	-	4.76	0.4
SPGN120408-1TP				0.8
SPGN120412-1TP				1.2
SPMN120404-1TP	12.7	-	4.76	0.4
SPMN120408-1TP				0.8
SPMN120412-1TP				1.2

SPGN/SPMN

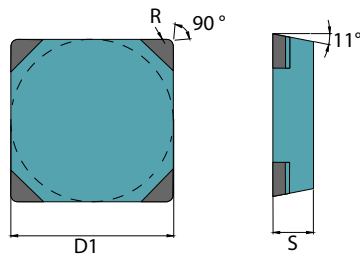

Designation	D1 [MM]	D2 [MM]	S [MM]	R
SPGN120404-4TP	12.7	-	4.76	0.4
SPGN120408-4TP				0.8
SPGN120412-4TP				1.2
SPMN120404-4TP	12.7	-	4.76	0.4
SPMN120408-4TP				0.8
SPMN120412-4TP				1.2

Order Note

- Please refer to B 01/02 for CBN inserts Code Key description.
- To place an order, please refer to the Designation code.
- For the item which not on the list pls contact us sales to get the quote.

SNGA/SNMA

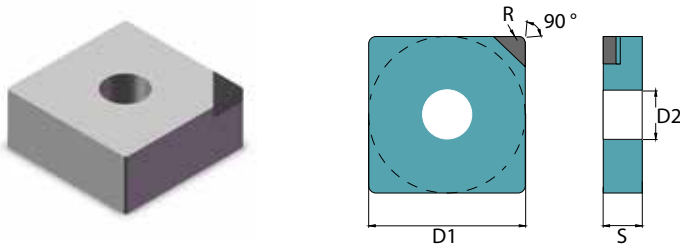

Designation	D1 [MM]	D2 [MM]	S [MM]	R
SNGA090304-1TP	9.525	3.81	3.18	0.4
SNGA090308-1TP				0.8
SNGA090312-1TP				1.2
SNMA090304-1TP	9.525	3.81	3.18	0.4
SNMA090308-1TP				0.8
SNMA090312-1TP				1.2

Designation	D1 [MM]	D2 [MM]	S [MM]	R
SNGA120404-1TP	12.7	5.16	4.76	0.4
SNGA120408-1TP				0.8
SNGA120412-1TP				1.2
SNMA120404-1TP	12.7	5.16	4.76	0.4
SNMA120408-1TP				0.8
SNMA120412-1TP				1.2

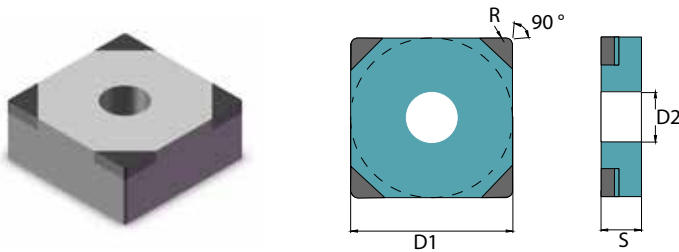

Designation	D1 [MM]	D2 [MM]	S [MM]	R
SNGA090304-4TP	9.525	3.81	3.18	0.4
SNGA090308-4TP				0.8
SNGA090312-4TP				1.2
SNMA090304-4TP	9.525	3.81	3.18	0.4
SNMA090308-4TP				0.8
SNMA090312-4TP				1.2

Designation	D1 [MM]	D2 [MM]	S [MM]	R
SNGA120408-4TP	12.7	5.16	4.76	0.8
SNGA120412-4TP				1.2
SNGA120416-4TP				1.6
SNMA120408-4TP	12.7	5.16	4.76	0.8
SNMA120412-4TP				1.2
SNMA120416-4TP				1.6

SNGA/SNMA-FULL EDGE

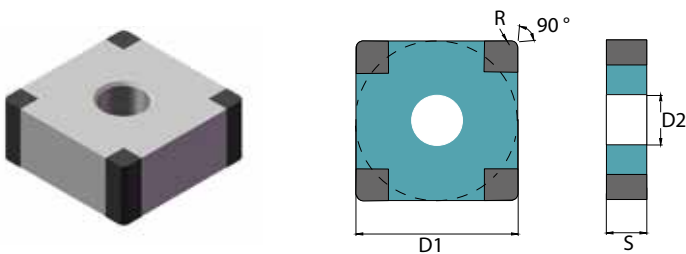

Designation	D1 [MM]	D2 [MM]	S [MM]	R
SNGA120404-4FE	12.7	5.16	4.76	0.4
SNGA120408-4FE				0.8
SNGA120412-4FE				1.2

SNGN/SNMN

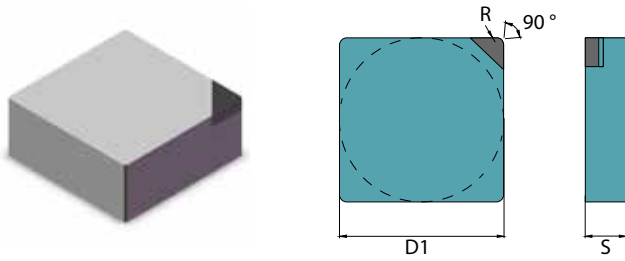

Designation	D1 [MM]	D2 [MM]	S [MM]	R
SNGN090304-1TP	9.525	-	3.18	0.4
SNGN090308-1TP				0.8
SNGN090312-1TP				1.2
SNMN090304-1TP	9.525	-	3.18	0.4
SNMN090308-1TP				0.8
SNMN090312-1TP				1.2

Designation	D1 [MM]	D2 [MM]	S [MM]	R
SNGN120404-1TP	12.7	-	4.76	0.4
SNGN120408-1TP				0.8
SNGN120412-1TP				1.2
SNMN120404-1TP	12.7	-	4.76	0.4
SNMN120408-1TP				0.8
SNMN120412-1TP				1.2

SPGN/SPMN

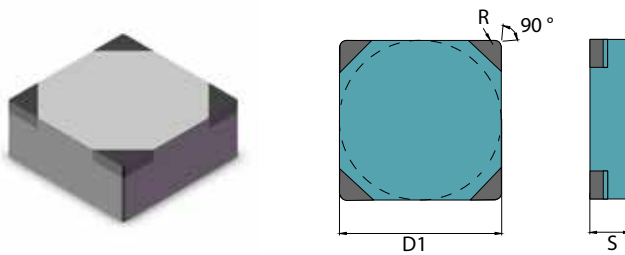

Designation	D1 [MM]	D2 [MM]	S [MM]	R
SNGN090304-4TP	9.525	-	3.18	0.4
SNGN090308-4TP				0.8
SNGN090312-4TP				1.2
SNMN090304-4TP	9.525	-	3.18	0.4
SNMN090308-4TP				0.8
SNMN090312-4TP				1.2

Order Note

- Please refer to B 01/02 for CBN inserts Code Key description.
- To place an order, please refer to the Designation code.
- For the item which not on the list pls contact us sales to get the quote.

WCGW/WCMW

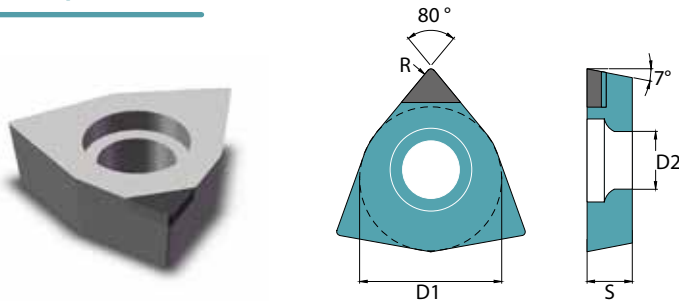

Designation	D1 [MM]	D2 [MM]	S [MM]	R
WCGW040202-1TP	6.35	2.8	2.38	0.2
WCGW040204-1TP				0.4
WCGW040208-1TP				0.8
WCMW040202-1TP	6.35	2.8	2.38	0.2
WCMW040204-1TP				0.4
WCMW040208-1TP				0.8

Designation	D1 [MM]	D2 [MM]	S [MM]	R
WCGT06T304-1TP	9.525	4.4	3.97	0.4
WCGT06T308-1TP				0.8
WCMT06T304-1TP	9.525	4.4	3.97	0.4
WCMT06T308-1TP				0.8

WCGW/WCMW

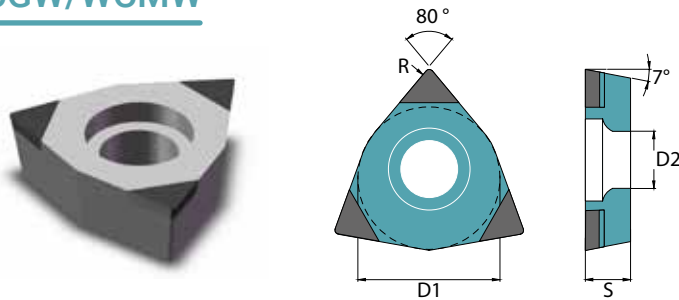

Designation	D1 [MM]	D2 [MM]	S [MM]	R
WCGW040202-3TP	6.35	2.8	2.38	0.2
WCGW040204-3TP				0.4
WCGW040208-3TP				0.8
WCMW040202-3TP	6.35	2.8	2.38	0.2
WCMW040204-3TP				0.4
WCMW040208-3TP				0.8

Designation	D1 [MM]	D2 [MM]	S [MM]	R
WCGT06T304-3TP	9.525	4.4	3.97	0.4
WCGT06T308-3TP				0.8
WCMT06T304-3TP	9.525	4.4	3.97	0.4
WCMT06T308-3TP				0.8

Order Note

- Please refer to B 01/02 for CBN inserts Code Key description.
- To place an order, please refer to the Designation code.
- For the item which not on the list pls contact us sales to get the quote.

WNGA/WNMA

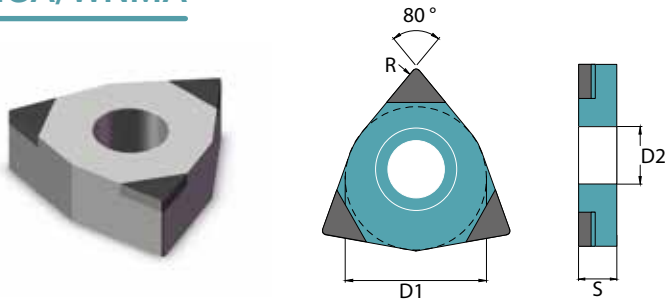

Designation	D1 [MM]	D2 [MM]	S [MM]	R
WNGA060404-3TP	9.525	3.81	4.76	0.4
WNGA060408-3TP				0.8
WNGA060412-3TP				1.2
WNGA060416-3TP				1.6
WNMA060404-3TP	9.525	3.81	4.76	0.4
WNMA060408-3TP				0.8
WNMA060412-3TP				1.2
WNMA060416-3TP				1.6

Designation	D1 [MM]	D2 [MM]	S [MM]	R
WNGA080404-3TP	12.7	5.16	4.76	0.4
WNGA080408-3TP				0.8
WNGA080412-3TP				1.2
WNGA080416-3TP				1.6
WNMA080404-3TP	12.7	5.16	4.76	0.4
WNMA080408-3TP				0.8
WNMA080412-3TP				1.2
WNMA080416-3TP				1.6

WNGA-FULL EDGE

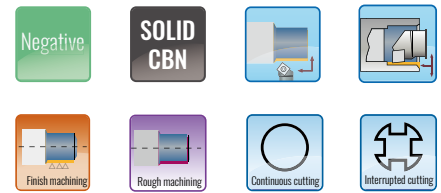
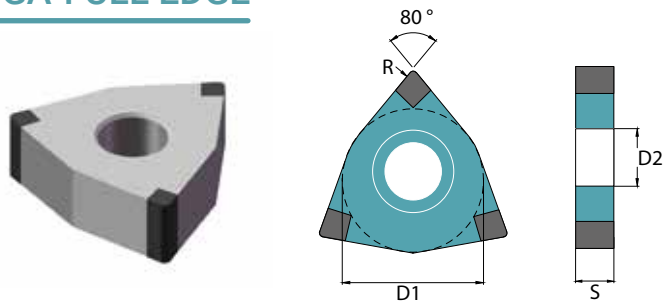

Designation	D1 [MM]	D2 [MM]	S [MM]	R
WNGA060404-3FE	9.525	3.81	4.76	0.4
WNGA060408-3FE				0.8
WNGA060412-3FE				1.2
WNGA080404-3FE	12.7	5.16	4.76	0.4
WNGA080408-3FE				0.8
WNGA080412-3FE				1.2

Order Note

- Please refer to B 01/02 for CBN inserts Code Key description.
- To place an order, please refer to the Designation code.
- For the item which not on the list pls contact us sales to get the quote.

What Are Solid CBN Inserts Used For

Solid CBN inserts have a great advantage in processing all ferrous materials, It is the first choice for hard turning the following material:

Cast Iron (Gray Iron, Ductile Iron, Chilled Cast Iron, High Chromium Cast Iron, Alloy Wear-resistant Cast Iron, etc.)

Hard Steel (Harden Steel, Bearing Steel, Die Steel, High Mn Steel, Hig-speed Steel, etc.)

Tungsten Carbide



CBN Grade And Recommend Application

Grade	SBN637	SBN500	SBN680	SBN630B	SBN2080
CBN V%	85-90	85-90	85-90	80-85	90-95
Ave particle size (µm)	12	6-12	17-20	20-25	4
Binder	Al-TiN	Al-TiN	Al-TiN	Al-TiN	Al-Co
Hardness (Hv)	3300-3600	3400-3700	3300-3500	3300-3500	3500-3700
Finish/Rough	Finish/Rough	Semifinishing	Rough/ Semifinishing	Rough	Finish
Continuous/ Intermittent processing	Continuous processing	Continuous processing	Both	Intermittent processing	Continuous/ light Intermittent
Suggest Handling Material	HSS, cast iron, hardened steel and other difficult processing materials.	HSS, cast iron, hardened steel and other difficult processing materials.	Gray Cast iron, ductile cast iron, high hard alloy cast iron, high nickel chromium, high chromium cast iron, high manganese steel	Gray Cast iron, ductile cast iron, high hard alloy cast iron, high nickel chromium, high chromium cast iron, high manganese steel	Gray Cast iron, ductile cast iron, pearlitic cast iron, Ferritic cast iron
Working material Hardness	HRC45-68	HRC55-68	HRC45-62	≅ HRC60	≅ HRC60

Solid CBN inserts For Roller



Roller Working Application	High Speed Steel Working Material	HSD80-85 Roller Hardness
Finish Machining Application	Excircle& Slot Machine Area	RC0604-V Inserts Selection

Full PCBN inserts For Gear



Driven Gear working application	20CrMnTiH working material	HRC 58-62 Roller hardness
Finish Machining Application	Excircle& End Face Machine Area	DN 1204 inserts selection

Solid CBN inserts For brake disc



Brake Disc working application	Hardness Steel working material	HB 190 Roller hardness
Finish Machining Application	Excircle& End Face Machine Area	CNGX 120712 inserts selection

CNGN

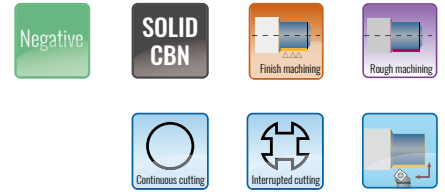
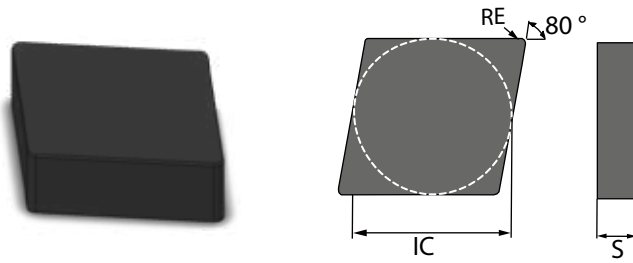

Item Code	IC	S	RE
CNGN090304-SF	9.525	3.18	0.4
CNGN090308-SF	9.525	3.18	0.8
CNGN090404-SF	9.525	4.76	0.4
CNGN090408-SF	9.525	4.76	0.8

Item Code	IC	S	RE
CNGN120404-SF	12.7	4.76	0.4
CNGN120408-SF	12.7	4.76	0.8
CNGN160404-SF	15.875	4.76	0.4
CNGN160408-SF	15.875	4.76	0.8

CNGX

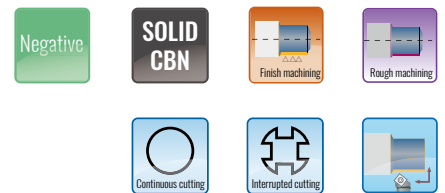
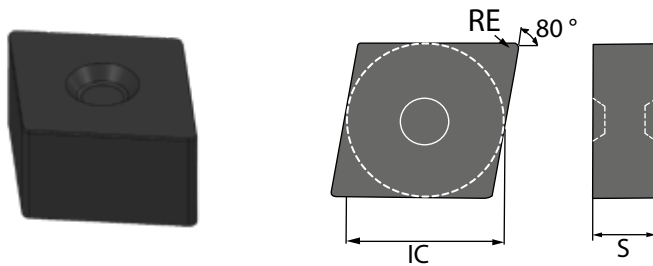

Item Code	IC	S	RE
CNGX120712-SF	12.7	7.94	1.2
CNGX120716-SF	12.7	7.94	1.6
CNGX160712-SF	15.875	7.94	1.2
CNGX160716-SF	15.875	7.94	1.6

Order Note

- Please refer to B 01/02 for CBN inserts Code Key description.
- To place an order, please refer to the Designation code.
- For the item which not on the list pls contact us sales to get the quote.

RNGN

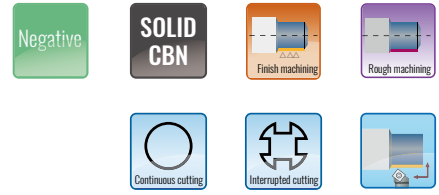
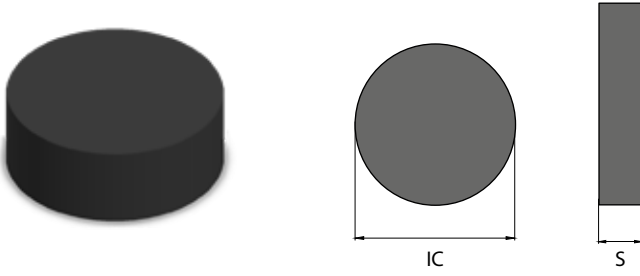

Item Code	IC	S	RE
RNGN060300-SF	6	3.18	0
RNGN060400-SF	6	4.76	0
RNGN060600-SF	6	6.35	0
RNGN090300-SF	9.525	3.18	0
RNGN090400-SF	9.525	4.76	0
RNGN090700-SF	9.525	7.94	0
RNGN120300-SF	12.7	3.18	0
RNGN120400-SF	12.7	4.76	0
RNGN120700-SF	12.7	7.94	0

Item Code	IC	S	RE
RNGN060300-SF	6	3.18	0
RNGN060400-SF	6	4.76	0
RNGN060600-SF	6	6.35	0
RNGN090300-SF	9.525	3.18	0
RNGN090400-SF	9.525	4.76	0
RNGN090700-SF	9.525	7.94	0
RNGN120300-SF	12.7	3.18	0
RNGN120400-SF	12.7	4.76	0
RNGN120700-SF	12.7	7.94	0

Order Note

- Please refer to B 01/02 for CBN inserts Code Key description.
- To place an order, please refer to the Designation code.
- For the item which not on the list pls contact us sales to get the quote.

RCGX-V

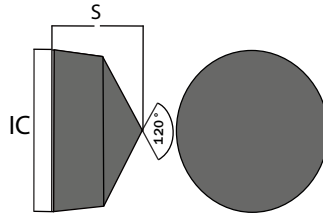

Item Code	IC	S	RE
RCGX060400V-SF	6.35	4.76	0
RCGX060600V-SF	6.35	6.35	0
RCGX090700V-SF	9.525	7.94	0
RCGX120700V-SF	12.7	7.94	0

Item Code	IC	S	RE
RCGX151000V-SF	15.875	10.0	0
RCGX191000V-SF	19.05	10.0	0
RCGX201200V-SF	20.0	12.0	0
RCGX251200V-SF	25.4	12.0	0

RCGX-Y

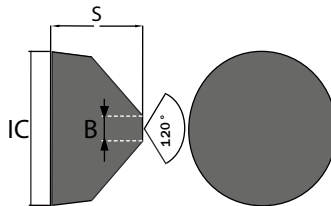

Item Code	IC	S	RE
RCGX060400Y-SF	6.35	4.76	0
RCGX060500Y-SF	6.35	5.0	0
RCGX060700Y-SF	6.35	7.94	0
RCGX090700Y-SF	9.525	7.94	0
RCGX120700Y-SF	12.7	7.94	0
RCGX191000Y-SF	19.05	10.0	0
RCGX201200Y-SF	20.0	12.0	0

Order Note

- Please refer to B 01/02 for CBN inserts Code Key description.
- To place an order, please refer to the Designation code.
- For the item which not on the list pls contact us sales to get the quote.

SCGN

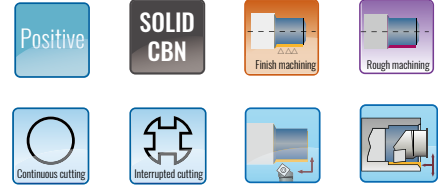
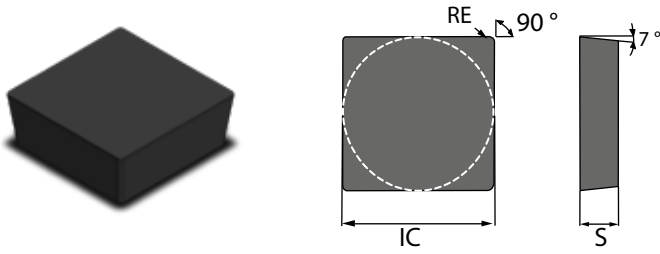

Item Code	IC	S	RE
SCGN060304-SF	6.35	3.18	0.4
SCGN060308-SF	6.35	3.18	0.8
SCGN060404-SF	6.35	4.76	0.4
SCGN060408-SF	6.35	4.76	0.8
SCGN090304-SF	9.525	3.18	0.4
SCGN090308-SF	9.525	3.18	0.8

Item Code	IC	S	RE
SCGN090404-SF	9.525	4.76	0.4
SCGN090408-SF	9.525	4.76	0.8
SCGN120404-SF	12.7	4.76	0.4
SCGN120408-SF	12.7	4.76	0.8
SCGN120712-SF	12.7	7.94	1.2
SCGN120714-SF	12.7	7.94	1.4

Order Note

- Please refer to B 01/02 for CBN inserts Code Key description.
- To place an order, please refer to the Designation code.
- For the item which not on the list pls contact us sales to get the quote.

SNGN

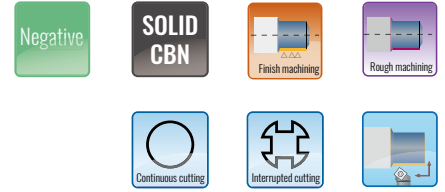
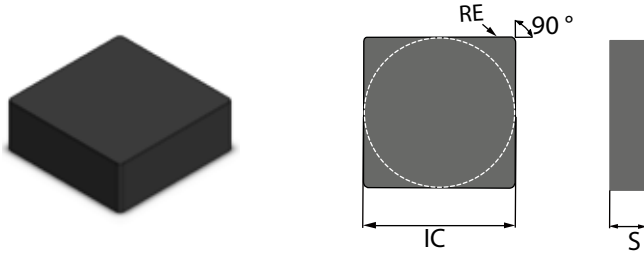

Item Code	IC	S	RE
SNGN060304-SF	6.35	3.18	0.4
SNGN060308-SF	6.35	3.18	0.8
SNGN060404-SF	6.35	4.76	0.4
SNGN060408-SF	6.35	4.76	0.8
SNGN090304-SF	9.525	3.18	0.4
SNGN090308-SF	9.525	3.18	0.8
SNGN090404-SF	9.525	4.76	0.4
SNGN090408-SF	9.525	4.76	0.8

Item Code	IC	S	RE
SNGN120404-SF	12.7	4.76	0.4
SNGN120408-SF	12.7	4.76	0.8
SNGN120712-SF	12.7	7.94	1.2
SNGN120714-SF	12.7	7.94	1.4
SNGN150712-SF	15.875	7.94	1.2
SNGN150714-SF	15.875	7.94	1.4
SNGN201012-SF	20	10	1.2
SNGN201014-SF	20	10	1.4

SNGX

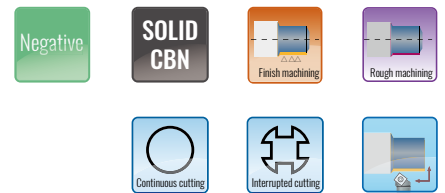
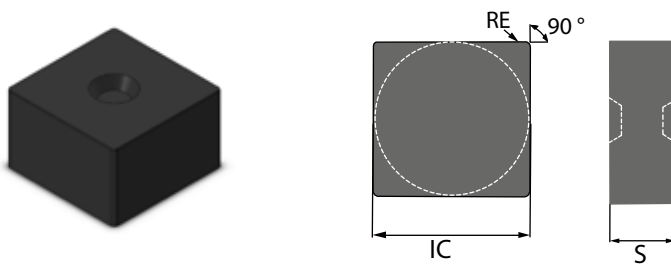

Item Code	IC	S	RE
SNGX120712-SF	12.7	7.94	1.2
SNGX120714-SF	12.7	7.94	1.4
SNGX150712-SF	15.875	7.94	1.2
SNGX150714-SF	15.875	7.94	1.4

Order Note

- Please refer to B 01/02 for CBN inserts Code Key description.
- To place an order, please refer to the Designation code.
- For the item which not on the list pls contact us sales to get the quote.

DNGN

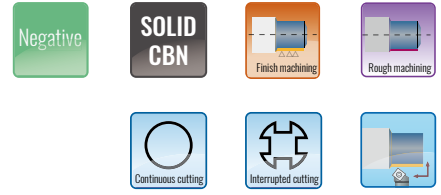
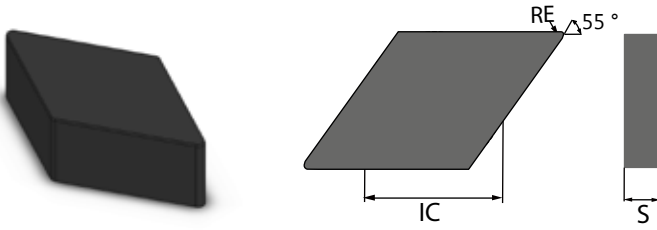

Item Code	IC	S	RE
DNGN110404-SF	9.525	4.76	0.4
DNGN110408-SF	9.525	4.76	0.8
DNGN110412-SF	9.525	4.76	1.2
DNGN150404-SF	12.7	4.76	0.4
DNGN150408-SF	12.7	4.76	0.8

Item Code	IC	S	RE
DNGN150412-SF	12.7	4.76	1.2
DNGN150604-SF	12.7	6.35	0.4
DNGN150608-SF	12.7	6.35	0.8
DNGN150612-SF	12.7	6.35	1.2

TPGN

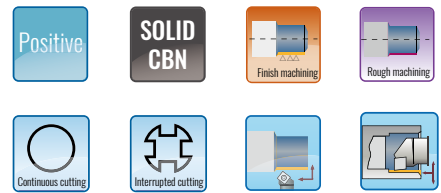
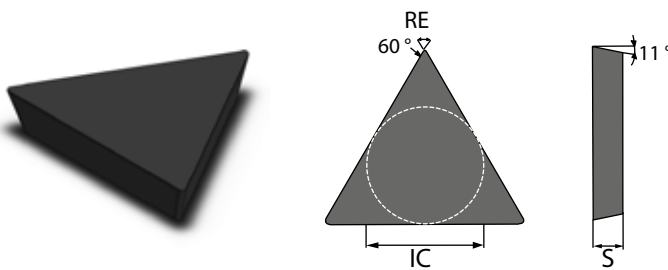

Item Code	IC	S	RE
TPGN110404-SF	6.35	4.76	0.4
TPGN110408-SF	6.35	4.76	0.8
TPGN110412-SF	6.35	4.76	1.2
TPGN160404-SF	9.525	4.76	0.4
TPGN160408-SF	9.525	4.76	0.8

Item Code	IC	S	RE
TPGN160412-SF	9.525	4.76	1.2
TPGN220408-SF	12.7	4.76	0.8
TPGN220412-SF	12.7	4.76	1.2
TPGN220416-SF	12.7	4.76	1.6

Order Note

- Please refer to B 01/02 for CBN inserts Code Key description.
- To place an order, please refer to the Designation code.
- For the item which not on the list pls contact us sales to get the quote.

TNGN

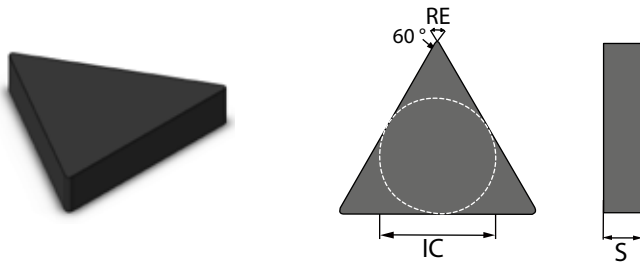

Item Code	IC	S	RE
TNGN110404-SF	6.35	4.76	0.4
TNGN110408-SF	6.35	4.76	0.8
TNGN110412-SF	6.35	4.76	1.2
TNGN160404-SF	9.525	4.76	0.4
TNGN160408-SF	9.525	4.76	0.8

Item Code	IC	S	RE
TNGN160412-SF	9.525	4.76	1.2
TNGN220408-SF	12.7	4.76	0.8
TNGN220412-SF	12.7	4.76	1.2
TNGN220416-SF	12.7	4.76	1.6

TNGX

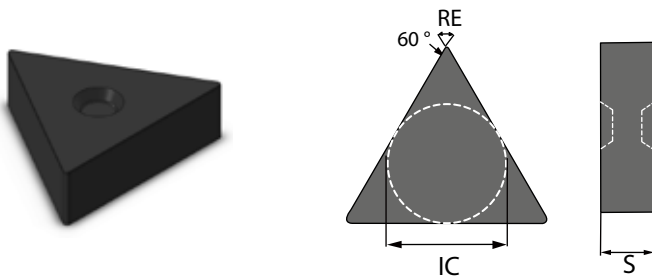

Item Code	IC	S	RE
TNGX110404-SF	6.35	4.76	0.4
TNGX110408-SF	6.35	4.76	0.8
TNGX110412-SF	6.35	4.76	1.2
TNGX160404-SF	9.525	4.76	0.4
TNGX160408-SF	9.525	4.76	0.8

Order Note

- Please refer to B 01/02 for CBN inserts Code Key description.
- To place an order, please refer to the Designation code.
- For the item which not on the list pls contact us sales to get the quote.

WNGN

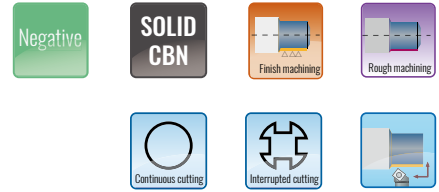
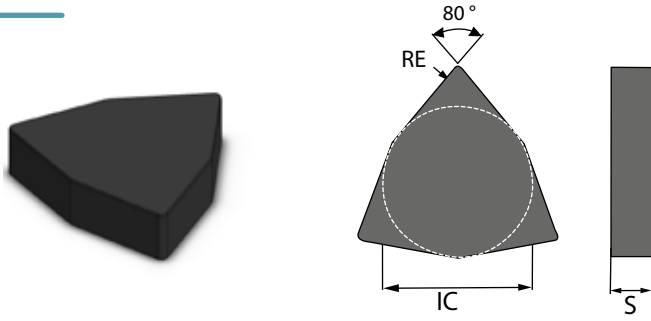

Item Code	IC	S	RE
WNGN080404-SF	12.7	4.76	0.4
WNGN080408-SF	12.7	4.76	0.8
WNGN080412-SF	12.7	4.76	1.2

WNGX

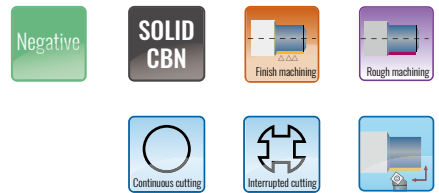
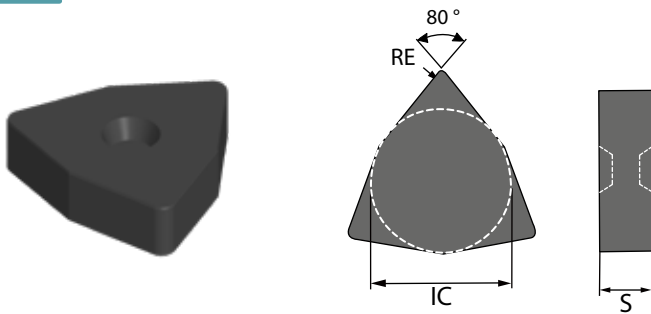

Item Code	IC	S	RE
WNGX080404-SF	12.7	4.76	0.4
WNGX080408-SF	12.7	4.76	0.8
WNGX080412-SF	12.7	4.76	1.2

Order Note

- Please refer to B 01/02 for CBN inserts Code Key description.
- To place an order, please refer to the Designation code.
- For the item which not on the list pls contact us sales to get the quote.