



PCD INSERTS

PCD tipped inserts
PCD inserts with chipbreak
PCD inserts with full edge
PCD custom-made inserts

Overview		A01 - A04
Code		A05 - A06
PCD tipped inserts	CCGW(T)/CCMW(T) DCGW(T)/DCMW(T) TCGW(T)/TCMW(T) TPGN(X)/TPMN(X) VBGW(T)/VCGW(T) WCGW(T)/WCMW(T) APKW/APKT	A07 - A13
PCD inserts with chipbreak	VBGW(T)/VBMW(T) TCGW/TCMW CCGW/CCMW DCGW/DCMW WCGW/WCMW	A14 - A16
PCD inserts with full edge	CCGW CCGT SCGW TCGW TCGT	A17 - A19
PCD custom-made inserts		A20

Overview

PCD inserts have a diamond layer on the surface of a carbide base, bonded at high temperatures and pressures with a binding agent. The bonded diamond coating makes the cutting surface and edges of the tool extremely hard and durable, suitable for a wide range of precision cutting operations including CNC turning and finishing of non-ferrous metals. PCD inserts are now commonly used across a wide range of machining and cutting processes in industry sectors ranging from woodworking and furniture manufacture to high-speed manufacture of aviation components and other special alloy parts.

Sundi Tools provides a complete range of PCD inserts for machining non-ferrous metals, designed to significantly increase tool life, achieve a uniform surface finish, and provide excellent dimensional control, resulting in higher productivity and cost reduction throughout the manufacturing process.



The Advantages of PCD inserts

- Consistent uniform wear, excellent thermal stability, and ultimate wear
- Delivers unparalleled part quality over long production runs
- Minimizes machine downtime
- cost-effective in the production
- long tool life
- resistance

PCD tools are highly wear-resistant and durable for cutting through tough materials. The addition of carbide bases provides strength and stability to the structure, making PCD tools ideal for precision cutting. The fine finish obtained by PCD polishing is often referred to as a "diamond" finish.

Due to their durability, PCD tools retain sharp edges much longer than traditional tools, leading to an excellent lifespan while maintaining high cutting and polishing accuracy. Additionally, they can be used to cut materials at high speeds, increasing removal rates and reducing machining time.



Introduce of Material & Behavior in Applications

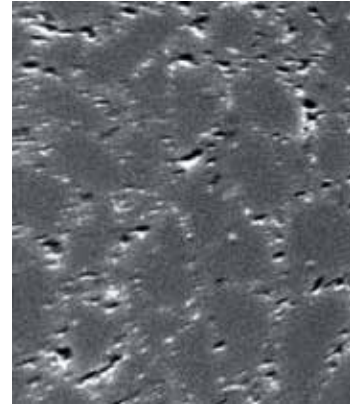
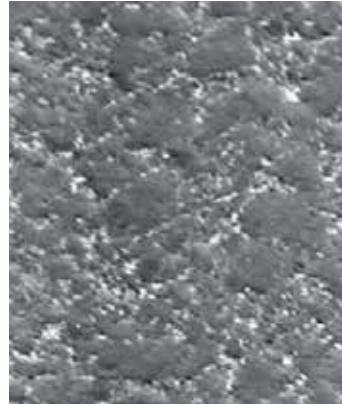
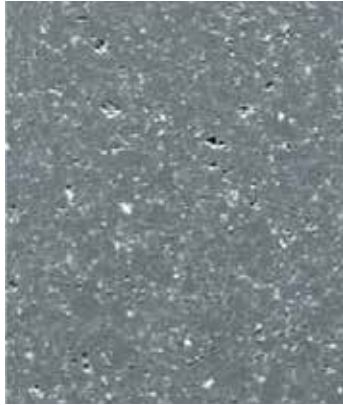
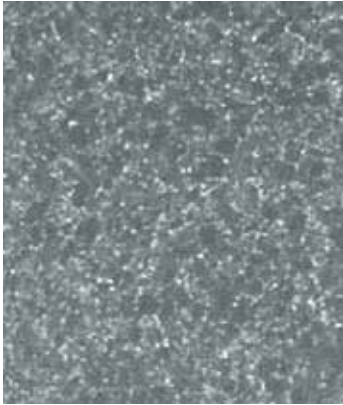

PCD-002

Excellent surface finishes for

- Aluminum, Copper, Precious Metals, Wood Composites, Plastics
- DIA Average particle size <2µm

PCD-010

High abrasion resistance and fine surface finishes for

- Aluminum Alloys (<14% Si), Copper Alloys, Graphite, and Graphite Composites
- DIA Average particle size 10µm

PCD-025

General purpose machining for

- Aluminum Alloys (>14% Si), Metal Matrix Composites, Wear Parts
- Sintered Ceramics and Carbides, Bi-Metals (Aluminum, Cast Iron)
- DIA Average particle size 25µm

PCD-030+

High abrasion and impact resistance for

- Aluminum Alloys (>14% Si)
- Fiberglass, Fiberboard, Wood Laminates
- DIA Average particle size 30 + Bi-modal

Behavior in Applications

Grade Characteristics	Grade Size	Chip Resistance	Abrasion Resistance
PCD-002	2µm	■ ■ ■ ■ ■ ■ ■ ■ ■ ■ □ □	■ ■ ■ ■ ■ ■ ■ □ □ □ □ □
PCD-010	10µm	■ ■ ■ ■ ■ ■ ■ ■ □ □	■ ■ ■ ■ ■ ■ ■ ■ ■ □ □
PCD-025	25µm	■ ■ ■ ■ ■ ■ ■ □ □ □	■ ■ ■ ■ ■ ■ ■ ■ ■ □
PCD-030+	2-30µm	■ ■ ■ ■ ■ ■ □ □ □ □	■ ■ ■ ■ ■ ■ ■ ■ ■ ■ ■

Chipping occurs when small notches form on the cutting edge, typically due to the load exceeding the material's strength.

Abrasion is characterized by the development of grooves and ridges on the tool flank in the direction of sliding. The abrasion resistance of PCD was evaluated on a high-silicon aluminum alloy.

Common Applications

- Aluminum alloys
- Silicon-aluminum alloys
- Brass and bronze alloys
- Copper alloys
- Zinc alloys
- Magnesium alloys
- Presintered tungsten carbide
- Sintered tungsten carbide
- Epoxy resins
- Fiberglass composites
- Carbon-phenolic
- Hard rubber
- Plastics
- Ceramics (unfired)
- Graphite

PCD inserts can be used in many fields, including aviation, the automotive industry, energy equipment, and the woodworking and stone industries. They can cut and process different materials such as non-ferrous metals, tungsten carbide, ceramics, non-metals, and composites.

While PCD tools are ideal for high-speed cutting of non-ferrous metals and alloys, they are not well-suited for cutting ferrous metals. Ferrous metals often contain carbides that react with the carbide base of PCD tools, causing increased wear and corrosion. For high-speed and precision cutting of ferrous metals, polycrystalline cubic boron nitride (PCBN) is a better choice.

Please contact us to discuss your specific needs.

Code

ISO

C	C	G	W	12	04	08	-	TP	N
1	2	3	4	5	6	7		8	9

1
Inserts Shape

A		R	
B		S	
C		T	
D		V	
		W	

2
Clearance Angle

B		N	
C		P	
D			

4
Machining and Fastening Feature

A		H		R	
B		M		T	
C		N		W	
F		Q		X	

Drawing or Precise description of indexable inserts required

3
Tolerances, ISO[MM]

	d	m	s
	A ±0.025	±0.005	±0.025
	C ±0.025	±0.013	±0.025
	E ±0.025	±0.025	±0.025
	F ±0.013	±0.005	±0.025
	G ±0.025	±0.025	±0.130
	H ±0.013	±0.013	±0.025
	J ±0.05~±0.15	±0.005	±0.025
	K ±0.05~±0.15	±0.013	±0.025
	L ±0.05~±0.15	±0.025	±0.025
	M ±0.05~±0.15	±0.08~±0.20	±0.130

5
Insert size

Inner circle diameter	Insert size						
	C	D	R	S	T	V	W
IC ISO Code							
IC ANSI							
3.97				03	06		03
5					08		
5.56				07	09		
6		06					
6.35	06	07	06		11	11	04
8	08		08				05
9.525	09	11	09	09	16	16	06
10			10				
12	12	15	12				
12.7	16		12	12	22	22	08
15.875			15	15	27		10
16			16				12
19.05			19	19	33		
20			20				
25							
25.4	25			25			
31.75							



ANSI

C	C	G	W	4	3	2	-	TP	N
1	2	3	4	5	6	7		8	9

6			
Thickness			
ISO		ANSI	
01	1.59	1	1/16
T1	1.98	1.2	0.75
02	2.38	1.5	3/32
T2	2.78	-	-
03	3.18	2	1/8
T3	3.97	2.5	5/32
04	4.76	3	3/16
05	5.56	3.5	7/32
06	6.36	4	1/4
07	7.94	5	5/16
09	9.52	6	3/8

7			
Corner radius r mm, Inch			
ISO		ANSI	
01	r=0.1	0.1	1/25
02	r=0.2	0	2/25
04	r=0.4	1	1/64
08	r=0.8	2	1/32
12	r=1.2	3	3/64
16	r=1.6	4	1/16
24	r=2.4	6	3/32
32	r=3.2	8	1/8

0 For diameters converted from imperial units to mm
M0 For diameters in metrica untis

8	
Inserts form	
	TP pcd brazed on corner
	TPB pcd blades with chipbreaker
	FE pcd brazed on one edge

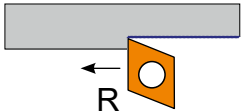
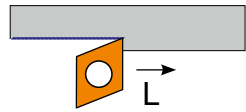
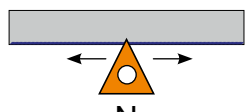
9	
Cutting direction	
	R
	L
	N

CCGW/CCMW

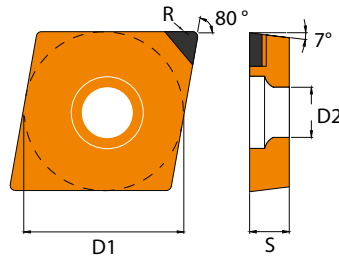
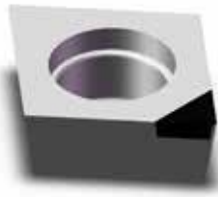

Designation	D1 [MM]	D2 [MM]	S [MM]	R
CCGW060204-TP	6.35	2.8	2.38	0.4
CCGW060208-TP				0.8
CCMW060202-TP	6.35	2.8	2.38	0.2
CCMW060204-TP				0.4
CCMW060208-TP				0.8
CCGW09T302-TP	9.525	4.4	3.97	0.2
CCGW09T304-TP				0.4
CCGW09T308-TP				0.8

Designation	D1 [MM]	D2 [MM]	S [MM]	R
CCMW09T304-TP	9.525	4.4	3.97	0.4
CCMW09T308-TP				0.8
CCGW120404-TP	12.7	5.5	4.76	0.4
CCGW120408-TP				0.8
CCGW120412-TP				1.2
CCMW120404-TP	12.7	5.5	4.76	0.4
CCMW120408-TP				0.8
CCMW120412-TP				1.2

CCGT/CCMT

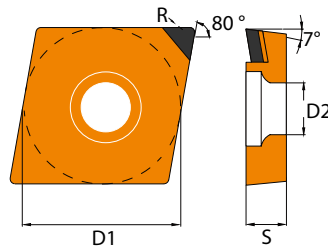
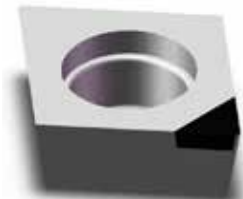

Designation	D1 [MM]	D2 [MM]	S [MM]	R
CCGT060204-TP	6.35	2.8	2.38	0.4
CCGT060208-TP				0.8
CCMT060202-TP	6.35	2.8	2.38	0.2
CCMT060204-TP				0.4
CCMT060208-TP				0.8
CCGT09T302-TP	9.525	4.4	3.97	0.2
CCGT09T304-TP				0.4
CCGT09T308-TP				0.8

Designation	D1 [MM]	D2 [MM]	S [MM]	R
CCMT09T304-TP	9.525	4.4	3.97	0.4
CCMT09T308-TP				0.8
CCGT120404-TP	12.7	5.5	4.76	0.4
CCGT120408-TP				0.8
CCGT120412-TP				1.2
CCMT120404-TP	12.7	5.5	4.76	0.4
CCMT120408-TP				0.8
CCMTW120412-TP				1.2

Order Note

- Please refer to B 01/02 for PCD inserts Code Key description.
- To place an order, please refer to the Designation code.
- For the item which not on the list pls contact us sales to get the quote.

DCGW/DCMW

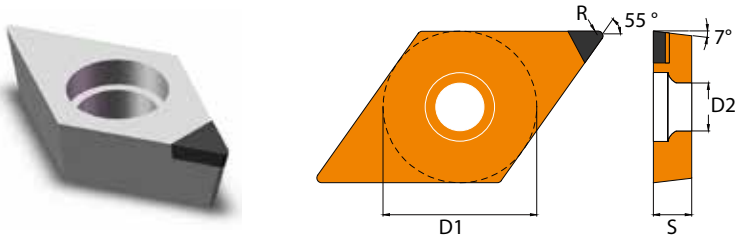

Designation	D1 [MM]	D2 [MM]	S [MM]	R
DCGW070202-TP	6.35	2.8	2.38	0.2
DCGW070204-TP				0.4
DCGW070208-TP				0.8
DCMW070202-TP	6.35	2.8	2.38	0.2
DCMW070204-TP				0.4
DCMW070208-TP				0.8

Designation	D1 [MM]	D2 [MM]	S [MM]	R
DCGW11T304-TP	9.525	4.4	3.97	0.4
DCGW11T308-TP				0.8
DCGW11T312-TP				1.2
DCMW11T304-TP	9.525	4.4	3.97	0.4
DCMW11T308-TP				0.8
DCMW11T312-TP				1.2

DCGT/DCMT

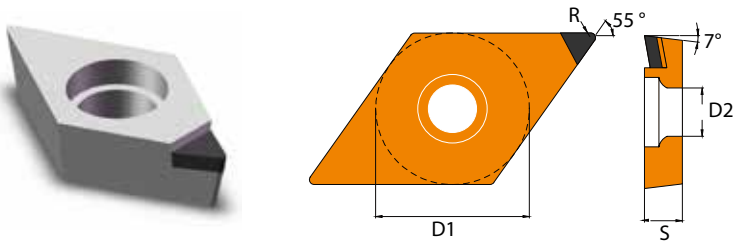

Designation	D1 [MM]	D2 [MM]	S [MM]	R
DCGT070202-TP	6.35	2.8	2.38	0.2
DCGT070204-TP				0.4
DCGT070208-TP				0.8
DCMT070202-TP	6.35	2.8	2.38	0.2
DCMT070204-TP				0.4
DCMT070208-TP				0.8

Designation	D1 [MM]	D2 [MM]	S [MM]	R
DCGT11T304-TP	9.525	4.4	3.97	0.4
DCGT11T308-TP				0.8
DCGT11T312-TP				1.2
DCMT11T304-TP	9.525	4.4	3.97	0.4
DCMT11T308-TP				0.8
DCMT11T312-TP				1.2

Order Note

- Please refer to B 01/02 for PCD inserts Code Key description.
- To place an order, please refer to the Designation code.
- For the item which not on the list pls contact us sales to get the quote.

TCGW/TCMW

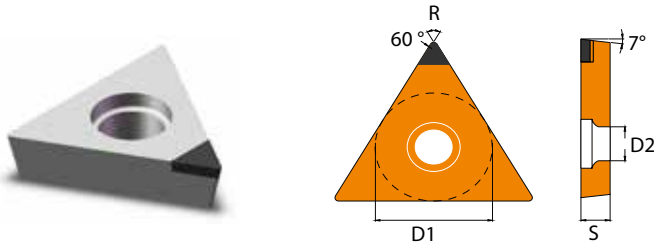

Designation	D1 [MM]	D2 [MM]	S [MM]	R
TCGW090204-TP	5.56	2.5	2.38	0.4
TCGW090208-TP				0.8
TCMW090204-TP	5.56	2.5	2.38	0.4
TCMW090208-TP				0.8
TCGW110204-TP	6.35	2.8	2.38	0.4
TCGW110208-TP				0.8

Designation	D1 [MM]	D2 [MM]	S [MM]	R
TCMW110204-TP	6.35	2.8	2.38	0.4
TCMW110208-TP				0.8
TCGW16T304-TP	9.525	4.4	3.97	0.4
TCGW16T308-TP				0.8
TCMW16T304-TP	9.525	4.4	3.97	0.4
TCMW16T308-TP				0.8

TCGT/TCMT

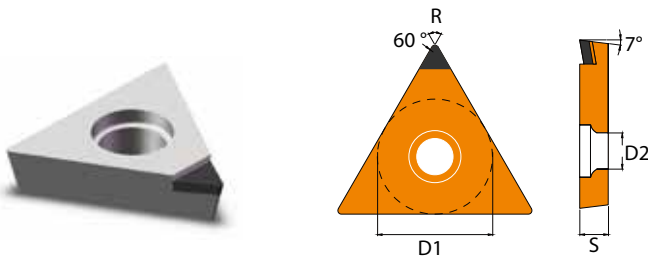

Designation	D1 [MM]	D2 [MM]	S [MM]	R
TCGT090204-TP	5.56	2.5	2.38	0.4
TCGT090208-TP				0.8
TCMT090204-TP	5.56	2.5	2.38	0.4
TCMT090208-TP				0.8
TCGT110204-TP	6.35	2.8	2.38	0.4
TCGT110208-TP				0.8

Designation	D1 [MM]	D2 [MM]	S [MM]	R
TCMT110204-TP	6.35	2.8	2.38	0.4
TCMT110208-TP				0.8
TCGT16T304-TP	9.525	4.4	3.97	0.4
TCGT16T308-TP				0.8
TCMT16T304-TP	9.525	4.4	3.97	0.4
TCMT16T308-TP				0.8

Order Note

- Please refer to B 01/02 for PCD inserts Code Key description.
- To place an order, please refer to the Designation code.
- For the item which not on the list pls contact us sales to get the quote.

TPGN/TPMN

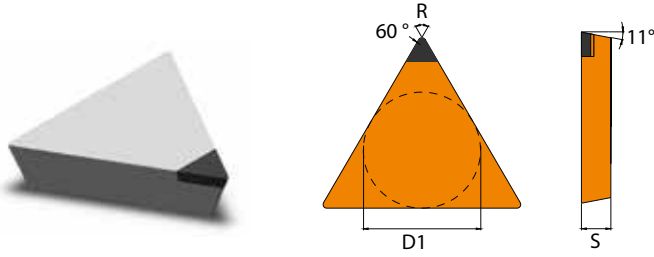

Designation	D1 [MM]	D2 [MM]	S [MM]	R
TPGN110302-TP	6.35	-	3.18	0.2
TPGN110304-TP				0.4
TPGN110308-TP				0.8
TPMN110302-TP	6.35	-	3.18	0.2
TPMN110304-TP				0.4
TPMN110308-TP				0.8

TPGX/TPMX

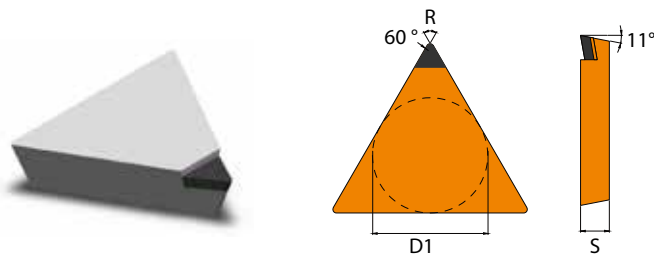

Designation	D1 [MM]	D2 [MM]	S [MM]	R
TPGX110302-TP	6.35	-	3.18	0.2
TPGX110304-TP				0.4
TPGX110308-TP				0.8
TPMX110302-TP	6.35	-	3.18	0.2
TPMX110304-TP				0.4
TPMX110308-TP				0.8

Order Note

- Please refer to B 01/02 for PCD inserts Code Key description.
- To place an order, please refer to the Designation code.
- For the item which not on the list pls contact us sales to get the quote.

VBGW/VCGW

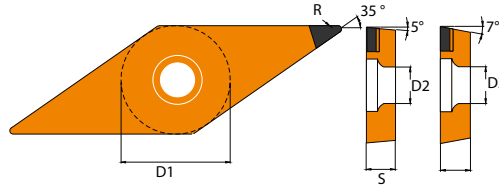
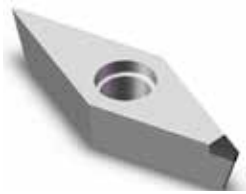

Designation	D1 [MM]	D2 [MM]	S [MM]	R
VBGW110302-TP	6.35	2.9	3.18	0.2
VBGW110304-TP				0.4
VBGW110308-TP				0.8
VBGW160404-TP	9.525	4.4	4.76	0.4
VBGW160408-TP				0.8
VBGW160412-TP				1.2

Designation	D1 [MM]	D2 [MM]	S [MM]	R
VCGW110302-TP	6.35	2.9	3.18	0.2
VCGW110304-TP				0.4
VCGW110308-TP				0.8
VCGW160404-TP	9.525	4.4	4.76	0.4
VCGW160408-TP				0.8
VCGW160412-TP				1.2

VBGT/VCGT

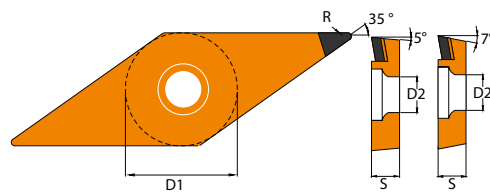

Designation	D1 [MM]	D2 [MM]	S [MM]	R
VBGT110302-TP	6.35	2.9	3.18	0.2
VBGT110304-TP				0.4
VBGT110308-TP				0.8
VBGT160404-TP	9.525	4.4	4.76	0.4
VBGT160408-TP				0.8
VBGT160412-TP				1.2

Designation	D1 [MM]	D2 [MM]	S [MM]	R
VCGT110302-TP	6.35	2.9	3.18	0.2
VCGT110304-TP				0.4
VCGT110308-TP				0.8
VCGT160404-TP	9.525	4.4	4.76	0.4
VCGT160408-TP				0.8
VCGT160412-TP				1.2

Order Note

- Please refer to B 01/02 for PCD inserts Code Key description.
- To place an order, please refer to the Designation code.
- For the item which not on the list pls contact us sales to get the quote.

WCGW/WCMW

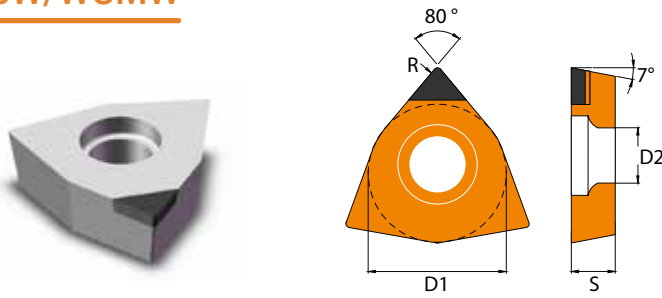

Designation	D1 [MM]	D2 [MM]	S [MM]	R
WCGW040202-TP	6.35	2.8	2.38	0.2
WCGW040204-TP				0.4
WCGW040208-TP				0.8
WCMW040202-TP	6.35	2.8	2.38	0.2
WCMW040204-TP				0.4
WCMW040208-TP				0.8

Designation	D1 [MM]	D2 [MM]	S [MM]	R
WCGW06T302-TP	9.525	4.4	3.97	0.2
WCGW06T304-TP				0.4
WCGW06T308-TP				0.8
WCMW06T302-TP	9.525	4.4	3.97	0.2
WCMW06T304-TP				0.4
WCMW06T308-TP				0.8

WCGT/WCMT

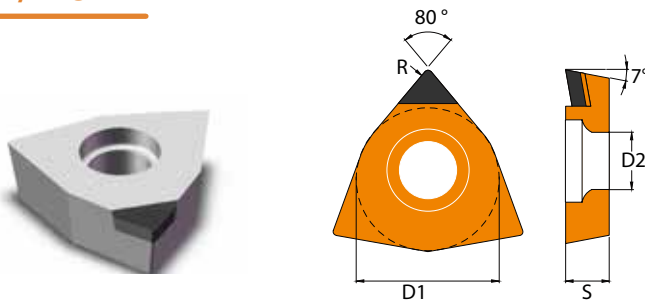

Designation	D1 [MM]	D2 [MM]	S [MM]	R
WCGT040202-TP	6.35	2.8	2.38	0.2
WCGT040204-TP				0.4
WCGT040208-TP				0.8
WCMT040202-TP	6.35	2.8	2.38	0.2
WCMT040204-TP				0.4
WCMT040208-TP				0.8

Designation	D1 [MM]	D2 [MM]	S [MM]	R
WCGT06T302-TP	9.525	4.4	3.97	0.2
WCGT06T304-TP				0.4
WCGT06T308-TP				0.8
WCMT06T302-TP	9.525	4.4	3.97	0.2
WCMT06T304-TP				0.4
WCMT06T308-TP				0.8

Order Note

- Please refer to B 01/02 for PCD inserts Code Key description.
- To place an order, please refer to the Designation code.
- For the item which not on the list pls contact us sales to get the quote.

APKW

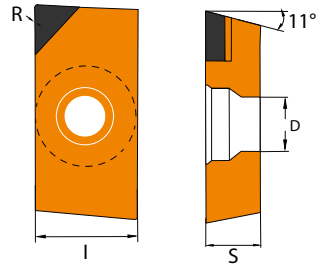
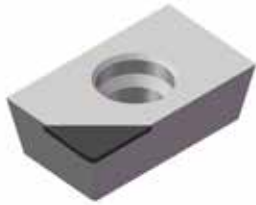

Designation	l [MM]	D [MM]	S [MM]	R
APKW110302-TP	6.35	2.8	3.18	0.2
APKW110304-TP				0.4
APKW110308-TP				0.8
APKW160302-TP	9.525	4.4	3.18	0.2
APKW160304-TP				0.4
APKW160308-TP				0.8

APKT

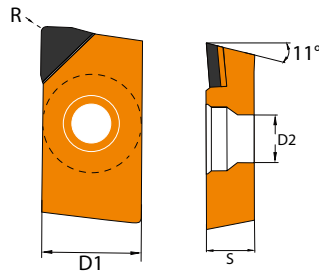
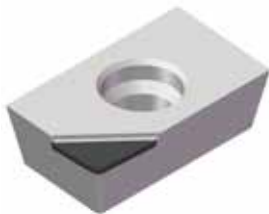

Designation	l [MM]	D [MM]	S [MM]	R
APKT110302-TP	6.35	2.8	3.18	0.2
APKT110304-TP				0.4
APKT110308-TP				0.8
APKT160302-TP	9.525	4.4	3.18	0.2
APKT160304-TP				0.4
APKT160308-TP				0.8

Order Note

- Please refer to B 01/02 for PCD inserts Code Key description.
- To place an order, please refer to the Designation code.
- For the item which not on the list pls contact us sales to get the quote.

VBGW(T)/VBMW(T)

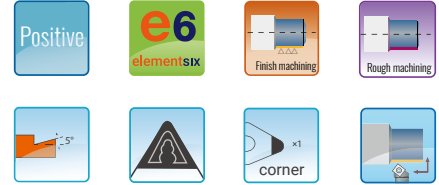
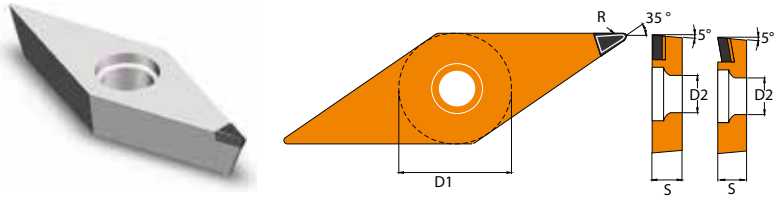

Designation	D1 [MM]	D2 [MM]	S [MM]	R
VBGW160404-TPB	9.525	4.4	4.76	0.4
VBGW160408-TPB				0.8
VBGW160412-TPB				1.2
VBMW160404-TPB	9.525	4.4	4.76	0.4
VBMW160408-TPB				0.8
VBMW160412-TPB				1.2

Designation	D1 [MM]	D2 [MM]	S [MM]	R
VBGT160404-TPB	9.525	4.4	4.76	0.4
VBGT160408-TPB				0.8
VBGT160412-TPB				1.2
VBMT160404-TPB	9.525	4.4	4.76	0.4
VBMT160408-TPB				0.8
VBMT160412-TPB				1.2

TCGW/TCMW

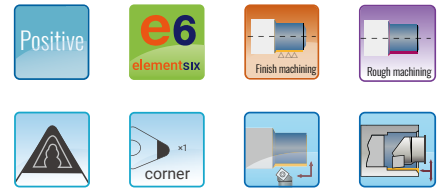
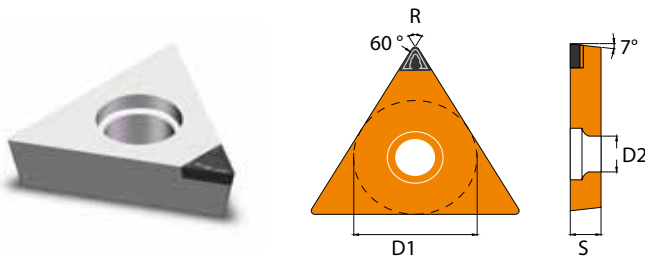

Designation	D1 [MM]	D2 [MM]	S [MM]	R
TCGW090204-TPB	5.56	2.5	2.38	0.4
TCGW090208-TPB				0.8
TCMW090204-TPB	5.56	2.5	2.38	0.4
TCMW090208-TPB				0.8
TCGW110204-TPB	6.35	2.8	2.38	0.4
TCGW110208-TPB				0.8

Designation	D1 [MM]	D2 [MM]	S [MM]	R
TCMW110204-TPB	6.35	2.8	2.38	0.4
TCMW110208-TPB				0.8
TCGW16T304-TPB	9.525	4.4	3.97	0.4
TCGW16T308-TPB				0.8
TCMW16T304-TPB	9.525	4.4	3.97	0.4
TCMW16T308-TPB				0.8

Order Note

- Please refer to B 01/02 for PCD inserts Code Key description.
- To place an order, please refer to the Designation code.
- For the item which not on the list pls contact us sales to get the quote.

CCGW/CCMW

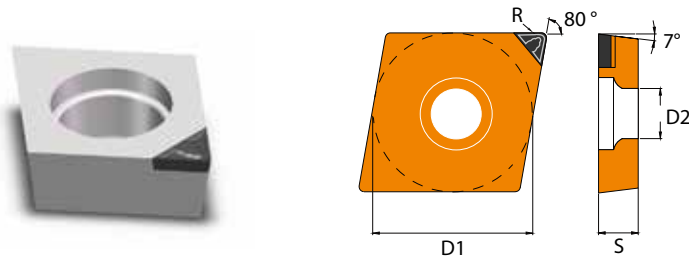

Designation	D1 [MM]	D2 [MM]	S [MM]	R
CCGW060204-TPB	6.35	2.8	2.38	0.4
CCGW060208-TPB				0.8
CCMW060202-TPB	6.35	2.8	2.38	0.2
CCMW060204-TPB				0.4
CCMW060208-TPB				0.8
CCGW09T302-TPB	9.525	4.4	3.97	0.2
CCGW09T304-TPB				0.4
CCGW09T308-TPB				0.8

Designation	D1 [MM]	D2 [MM]	S [MM]	R
CCMW09T304-TPB	9.525	4.4	3.97	0.4
CCMW09T308-TPB				0.8
CCGW120404-TPB	12.7	5.5	4.76	0.4
CCGW120408-TPB				0.8
CCGW120412-TPB				1.2
CCMW120404-TPB	12.7	5.5	4.76	0.4
CCMW120408-TPB				0.8
CCMW120412-TPB				1.2

DCGW/DCMW

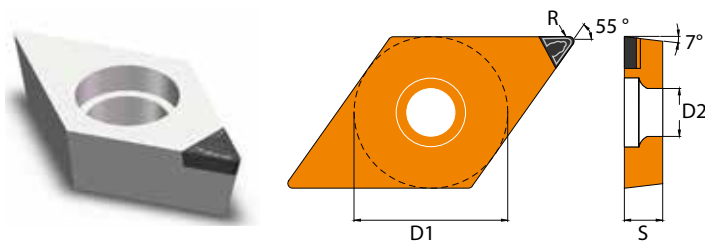

Designation	D1 [MM]	D2 [MM]	S [MM]	R
DCGW070202-TPB	6.35	2.8	2.38	0.2
DCGW070204-TPB				0.4
DCGW070208-TPB				0.8
DCMW070202-TPB	6.35	2.8	2.38	0.2
DCMW070204-TPB				0.4
DCMW070208-TPB				0.8

Designation	D1 [MM]	D2 [MM]	S [MM]	R
DCGW11T304-TPB	9.525	4.4	3.97	0.4
DCGW11T308-TPB				0.8
DCGW11T312-TPB				1.2
DCMW11T304-TPB	9.525	4.4	3.97	0.4
DCMW11T308-TPB				0.8
DCMW11T312-TPB				1.2

Order Note

- Please refer to B 01/02 for PCD inserts Code Key description.
- To place an order, please refer to the Designation code.
- For the item which not on the list pls contact us sales to get the quote.

WCGW/WCMW

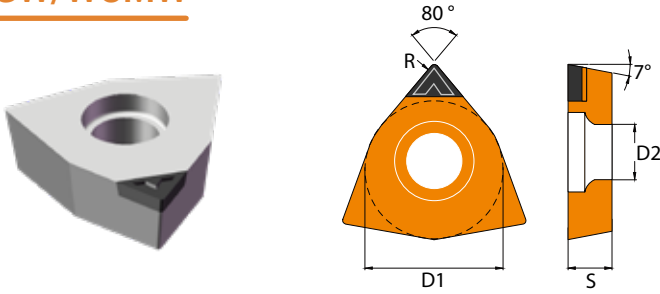

Designation	D1 [MM]	D2 [MM]	S [MM]	R
WCGW040202-TPB	6.35	2.8	2.38	0.2
WCGW040204-TPB				0.4
WCGW040208-TPB				0.8
WCMW040202-TPB	6.35	2.8	2.38	0.2
WCMW040204-TPB				0.4
WCMW040208-TPB				0.8

Designation	D1 [MM]	D2 [MM]	S [MM]	R
WCGW06T302-TPB	9.525	4.4	3.97	0.2
WCGW06T304-TPB				0.4
WCGW06T308-TPB				0.8
WCMW06T302-TPB	9.525	4.4	3.97	0.2
WCMW06T304-TPB				0.4
WCMW06T308-TPB				0.8

Order Note

- Please refer to B 01/02 for PCD inserts Code Key description.
- To place an order, please refer to the Designation code.
- For the item which not on the list pls contact us sales to get the quote.

CCGW-FULL EDGE

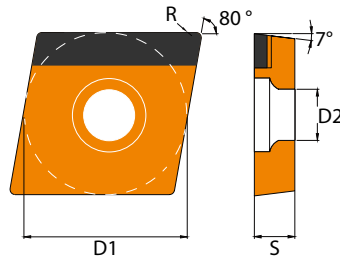

Designation	D1 [MM]	D2 [MM]	S [MM]	R
CCGW060204-FE	6.35	2.8	2.38	0.4
CCGW060208-FE				0.8
CCGW09T308-FE	9.525	4.4	3.97	0.8
CCGW09T312-FE				1.2
CCGW120412-FE	12.7	5.5	4.76	1.2

CCGT-FULL EDGE

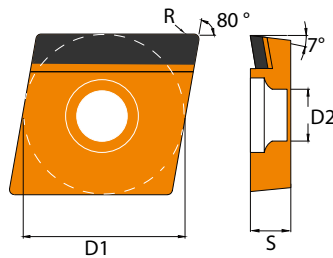

Designation	D1 [MM]	D2 [MM]	S [MM]	R
CCGT060204-FE	6.35	2.8	2.38	0.4
CCGT060208-FE				0.8
CCGT09T308-FE	9.525	4.4	3.97	0.8
CCGT09T312-FE				1.2
CCGT120412-FE	12.7	5.5	4.76	1.2

Order Note

- Please refer to B 01/02 for PCD inserts Code Key description.
- To place an order, please refer to the Designation code.
- For the item which not on the list pls contact us sales to get the quote.

SCGW-FULL EDGE

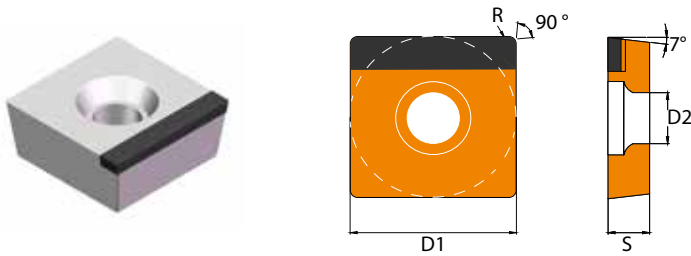

Designation	D1 [MM]	D2 [MM]	S [MM]	R
SCGW09T304-FE	9.525	4.4	3.97	0.4
SCGW09T308-FE				0.8
SCGW120404-FE	12.7	5.16	4.76	0.4
SCGW120408-FE				0.8
SCGW120412-FE				1.2

SCGW- Chipbreaker

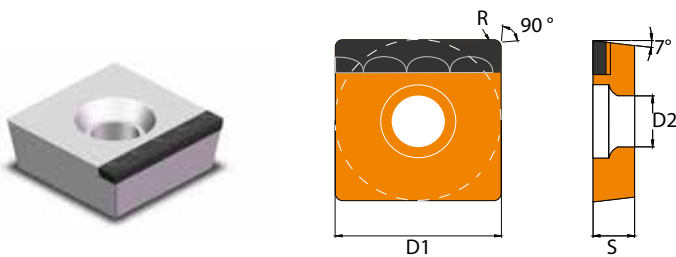

Designation	D1 [MM]	D2 [MM]	S [MM]	R
SCGW09T304-FEB	9.525	4.4	3.97	0.4
SCGW09T308-FEB				0.8
SCGW120404-FEB	12.7	5.16	4.76	0.4
SCGW120408-FEB				0.8
SCGW120412-FEB				1.2

Order Note

- Please refer to B 01/02 for PCD inserts Code Key description.
- To place an order, please refer to the Designation code.
- For the item which not on the list pls contact us sales to get the quote.

TCGW-FULL EDGE

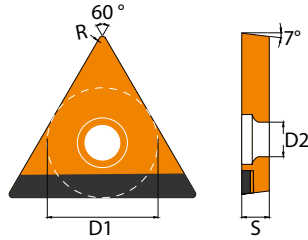

Designation	D1 [MM]	D2 [MM]	S [MM]	R
TCGW090202-FE	5.56	2.5	2.38	0.2
TCGW110204-FE	6.35	2.8	2.38	0.4
TCGW110208-FE				0.8
TCGW16T304-FE	9.525	4.4	3.97	0.4
TCGW16T308-FE				0.8

TCGT-FULL EDGE

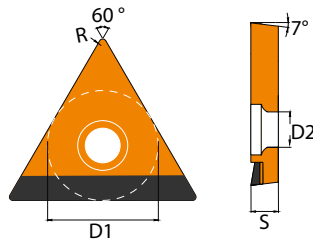

Designation	D1 [MM]	D2 [MM]	S [MM]	R
TCGT090202-FE	5.56	2.5	2.38	0.2
TCGT110204-FE	6.35	2.8	2.38	0.4
TCGT110208-FE				0.8
TCGT16T304-FE	9.525	4.4	3.97	0.4
TCGT16T308-FE				0.8

Order Note

- Please refer to B 01/02 for PCD inserts Code Key description.
- To place an order, please refer to the Designation code.
- For the item which not on the list pls contact us sales to get the quote.



1. PCD TIP Custom-made Milling(router) Bit

- The tipped PCD blade is sourced from E6, with stable performance and long service life.
- Sharp cutting edge, high-speed cutting for non-ferrous metals and non-metallic material.
- No stick to the cutting tools during processing.

Process	Router , Milling
Working Material	Aluminum , CFPR, Graphite
Tolerance	0.01~0.005MM



2. PCD Full Edge For Turning(Milling) Graphite

- The PCD inserts are used for milling graphite and other difficult machining material.
- PCD blade is tipped with a full edge making the best use of processing efficiency and tooling life.
- High wear resistance, good thermal conductivity

Process	Turning , Face Milling
Working Material	Aluminum , Graphite
Tolerance	0.025~0.015MM



3. PCD Custom-made Face Milling Bits

- High precision, the dimension differences between inserts are less than 0.025mm.
- High wear resistance, good thermal conductivity, and longer working life.
- Great performance for high-speed cutting the hardened mate.

Process	Face Milling
Working Material	Aluminum
Tolerance	0.025~0.015MM

Order Note

- Please refer to B 01/02 for PCD inserts Code Key description.
- To place an order, please refer to the Designation code.
- For the item which not on the list pls contact us sales to get the quote.