

2023

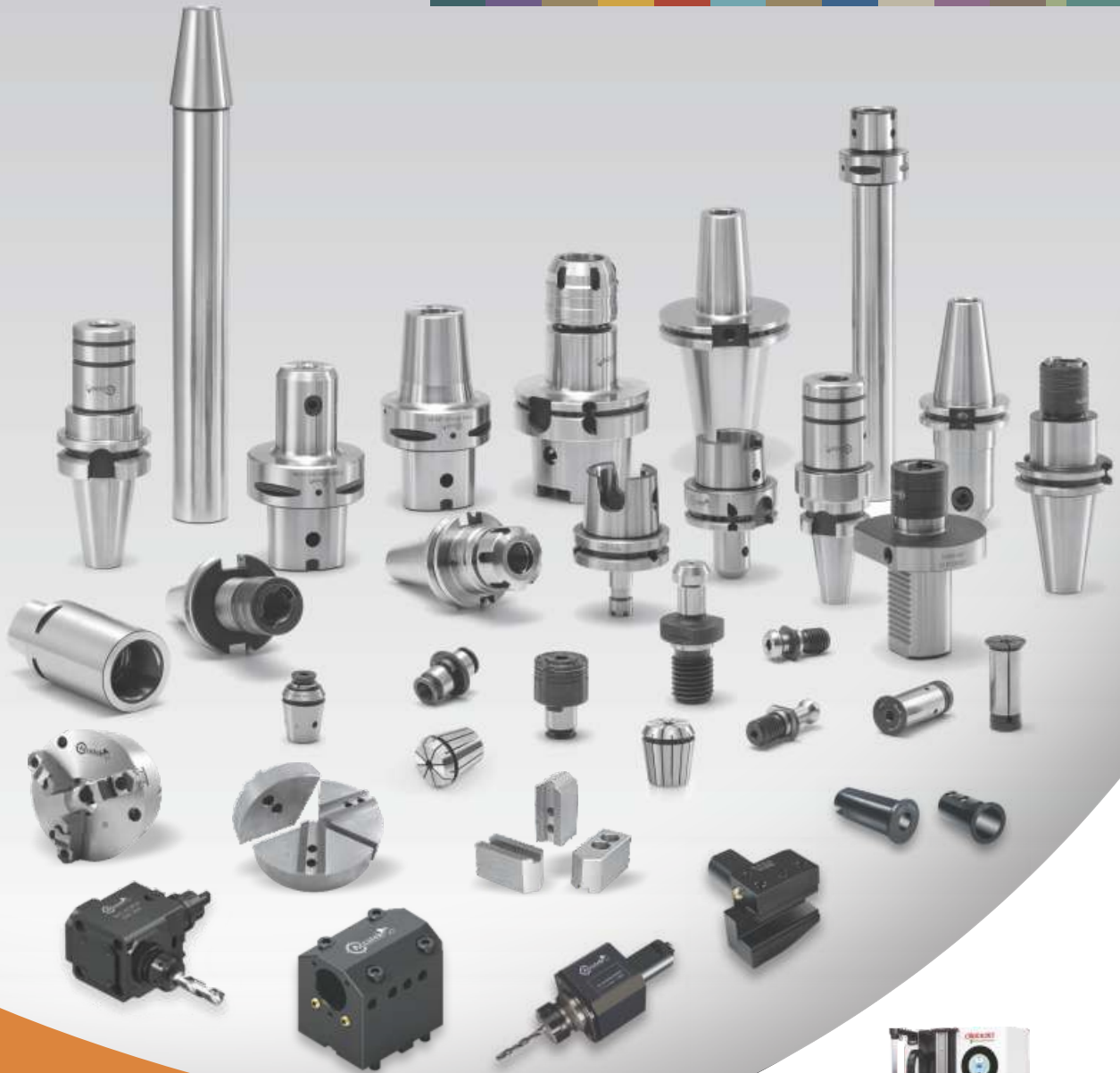

True Efficiency & Precision Delivered

Complete Tool Holding Solutions focused on Precision,
Performance and Total Cost of Ownership

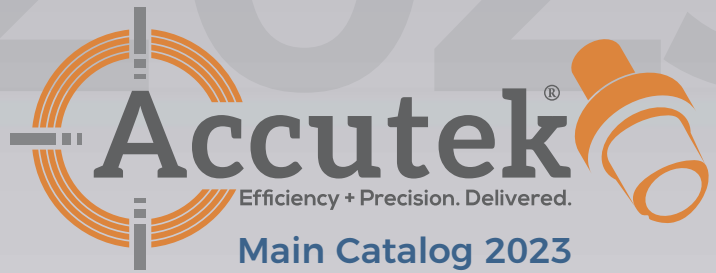

Official North American distributor of
Helmut Diebold GmbH & Co. Products



CNC Tooling System by Accutek®

AccuClamp™	Hydraulic Tool Holding
AccuGrip™	Shrink Fit Tooling
AccuLock™	Polygon Taper Interface (PTI) - Sandvik Capto® equivalent ISO 26623-1 tooling KM Taper Interface (KTI) - ISO26622-1 tooling
AccuMill™	MultiMill Chuck (MMC) System
AccuPlus™	Face Contact Sleep Taper Shank Tooling
AccuTap™	Tapping Product Range
AccuTrac™	Threaded Connection Chucks



TABLE OF CONTENTS

Accutek® Offering Overview	9
Tool holder Selection Guide	14
Spindle Selection	14
Tool Clamping Technology and Selection	16
AccuPlus™ Steep-Taper Face-Contact Chucks Technical Features	18
Balancing Guide	20
Diebold Product Offer Overview	25
CAT Taper Holders	30
CAT40 End Mill Holder (ANSI/ASME B5.50-1994)	30
CAT40 End Mill Holder X-Long (ANSI/ASME B5.50-1994)	32
CAT40 End Mill Holder IK (ANSI/ASME B5.50-1994)	33
CAT40 Morse Taper Socket (ANSI/ASME B5.50-1994)	34
CAT40 Shell Mill Holder (ANSI/ASME B5.50-1994)	34
CAT40 Shell Mill Holder X-Long (ANSI/ASME B5.50-1994)	35
CAT40 Jacob Taper Holder (ANSI-ASME BS.50-1994)	35
CAT40 ER Collet Holder (ANSI/ASME B5.50-1994)	36
CAT40 AccuMill™ Multi-Milling Chuck (ANSI/ASME B5.50-1994)	37
CAT40 AccuClamp™ Hydraulic Chuck (ANSI/ASME B5.50-1994)	37
CAT40 AccuClamp™ Hydraulic Chuck Slim Design (ANSI/ASME B5.50-1994)	38
CAT40 AccuClamp™ Heavy Duty Hydraulic Chuck (ANSI/ASME B5.50-1994)	38
CAT50 End Mill Holder (ANSI/ASME B5.50-1994)	39
CAT50 End Mill Holder X-Long (ANSI/ASME B5.50-1994)	40
CAT50 End Mill Holder IK (ANSI/ASME B5.50-1994)	41
CAT50 Shell Mill Holder (ANSI/ASME B5.500-1994)	42
CAT50 Shell Mill Holder X-Long (ANSI/ASME B5.500-1994)	43
CAT50 ER Collet Holder (ANSI/ASME B5.50-1994)	44
CAT40/50 TG Collet Holder (ANSI/ASME B5.50-1994)	45
CAT50 AccuMill™ Multi-Milling Chuck (ANSI/ASME B5.50-1994)	46
CAT50 AccuClamp™ Hydraulic Chuck (ANSI/ASME B5.50-1994)	46
CAT50 AccuClamp™ Hydraulic Chuck Slim Design (ANSI/ASME B5.50-1994)	47
CAT50 AccuClamp™ Heavy Duty Hydraulic Chucks (ANSI/ASME B5.50-1994)	47
CAT50 Morse Taper Holder (ANSI/ASME B5.50-1994)	48
CAT50 Jacob Taper Holder (ANSI-ASME BS.50-1994)	48
CAT ER-Z Short Collet Chuck (ANSI/ASME B5.50-1994)	49
BT ER-Z Short Collet Chuck (MAS 403)	49
CATP AccuPlus™ Face Contact Holders	50
AccuPlus™ CATP40 Face Contact End Mill Holder	50
AccuPlus™ CATP40 Face Contact ER Collet Holder	51

AccuPlus™ CATP40 Face Contact Shell Mill Holder	52
AccuPlus™ CATP40 Face Contact Hydraulic Chuck	52
AccuPlus™ CATP40 Face Contact AccuMill™ Multi-Milling Chuck	53
AccuPlus™ CATP40 AccuClamp™ Face Contact Hydraulic Chuck Slim Design (ANSI/ASME B5.50-1994)	54
AccuPlus™ CATP40 AccuClamp™ Heavy Duty Hydraulic Chuck (ANSI-ASME B5.50-1994)	54
AccuPlus™ CATP50 Face Contact End Mill Holder	55
AccuPlus™ CATP50 Face Contact ER Collet Holder	56
AccuPlus™ CATP50 Face Contact Shell Mill Holder	57
AccuPlus™ CATP50 Face Contact AccuMill™ Multi-Milling Chuck	58
AccuPlus™ CATP50 AccuClamp™ Face Contact Hydraulic Chuck (ANSI/ASME BS.50-1994)	58
AccuPlus™ CATP50 AccuClamp™ Face Contact Hydraulic Chuck Slim Design (ANSI/ASME B5.50-1994)	59
AccuPlus™ CATP50 AccuClamp™ Heavy Duty Hydraulic Chuck (ANSI/ASME B5.50-1994)	59
BT Taper Holders	60
BT End Mill Holder (MAS403)	60
BT ER Collet Chuck (MAS 403)	61
BT Shell Mill Holder (MAS 403)	62
BT AccuMill™ Multi-Milling Chuck (MAS 403)	63
BT AccuClamp™ Hydraulic Chuck (MAS 403)	63
BT30 AccuClamp™ Hydraulic Chuck Slim Design (MAS 403)	64
BTP AccuPlus™ Face Contact Holders	65
BTP End Mill Holder	66
BTP ER Collet Chuck	67
BTP Shell Mill Holder	68
BTP AccuMill™ Multi-Milling Chuck	69
BTP AccuMill™ Hydraulic Chuck	69
HSK Taper Holders	70
HSK End Mill Holder (DIN 6499 AND DIN 1835/B) - Inch ID	70
HSK End Mill Holder (DIN 6499 AND DIN 1835/B) - Metric ID	71
HSK-A ER Collet Chuck (DIN 69893 A+C)	72
HSK-A Shell Mill Holder (DIN 69893 A+C)	73
HSK-A AccuMill™ Multi-Milling Chuck (DIN 69893 A+C)	74
HSK-A AccuClamp™ Hydraulic Chuck (DIN 69893 A+C)	74
HSK-A Morse Taper Holder (DIN 69893 A+C)	75
CAT Vs HSK-A Extension Holder	75
HSK-E 40 Endmill Holder	76
HSK-E 40 ER Collet Chuck	76
HSK-E 40 Shell Mill Holder	76
PTI Taper Holders	78
PTI End Mill Holder (ISO 26623-1)	78
PTI ER Collet Holder (ISO 26623-1)	79

PTI Shell Mill Holder (ISO 26623-1)	81
PTI AccuMill™ Multi-Milling Chuck (ISO 26623-1)	82
PTI Hydraulic Chuck (ISO 26623-1)	82
PTI Extension Adapter (ISO 26623-2)	83
PTI Extension Front Clamping	84
PTI Reduction Adaptor	85
PTI Indexable Static Turning Tools	86
PTI Square Shank Holder (ISO26623-1)	89
KTI Taper Holders	90
KTI End Mill Holder (ISO26622-1)	90
KTI ER Collet Holder (ISO 26622-1)	91
KTI TG Collect Chuck (ISO 26622-1)	92
KTI Shell Mill Holder (ISO 26622-1)	92
KTI Extension Front Clamping	93
KTI Static Indexable Turning Tools (ISO 26622-1)	94
KTI Square Shank Holder (ISO26622-1)	97
AccuGrip™ Shrink Fit Technology Offering	98
Shrink Fit Unit Technology by Diebold	101
Diebold / Accutek Horizontal Shrink Unit	107
Diebold / Accutek Vertical Shrink Unit	108
Diebold / Accutek Micro Shrink MS 3.0 Unit	109
Diebold / Accutek Shrink Unit US 1100H Horizontal Unit	110
Diebold / Accutek Shrink Unit US 1100V Vertical Unit	111
Diebold / Accutek Shrink Unit US 1100V Vertical with TubeChiller®	112
Diebold / Accutek Shrink Fit Unit Accessories	113
CAT40 AccuGrip™ Shrink Fit Holders – Standard DIN Length	114
CAT40 AccuGrip™ Shrink Fit Holders – Long DIN Length	115
CAT40 AccuGrip™ Shrink Fit Holders – X-Long DIN Length	116
CAT50 AccuGrip™ Shrink Fit Holders – Standard DIN Length	117
CAT50 AccuGrip™ Shrink Fit Holders – Long DIN Length	118
CAT50 AccuGrip™ Shrink Fit Holders – X-Long DIN Length	119
BT30 AccuGrip™ Shrink Fit Holders – Standard DIN Length	120
BT40 AccuGrip™ Shrink Fit Holders – Standard DIN Length	121
BT40 AccuGrip™ Shrink Fit Holders – Long DIN Length	122
BT40 AccuGrip™ Shrink Fit Holders – X-Long DIN Length	123
HSK63A AccuGrip™ Shrink Fit Holders – Standard DIN Length	124
HSK63A AccuGrip™ Shrink Fit Holders – Long DIN Length	125
HSK63A AccuGrip™ Shrink Fit Holders – X-Long DIN Length	126
HSK100A AccuGrip™ Shrink Fit Holders – Standard DIN Length	127
HSK63F AccuGrip™ Shrink Fit Holders – Standard DIN Length	128

Straight Shank Extension AccuGrip™ Shrink Fit Holders	128
PTI AccuGrip™ Shrink Fit Holders – Standard DIN Length - Metric ID	129
PTI AccuGrip™ Shrink Fit Holders – Standard DIN Length - Inch ID	130
CATP40 AccuPlus™ Face Contact AccuGrip™ Shrink Fit Holders	131
CATP50 AccuPlus™ Face Contact AccuGrip™ Shrink Fit Holders	132
BTP30 AccuPlus™ Face Contact AccuGrip™ Shrink Fit Holders	133
BTP40 AccuPlus™ Face Contact AccuGrip™ Shrink Fit Holders	134
HSK63A / CAT40 AccuGrip™ Shrink Fit Slim Line Holders	135
KTI AccuGrip Shrink Fit Holders (ISO 26622-1)	136
AccuGrip™ Modular Slim Holders (Model SFSEH)	137
AccuGrip™ Modular Slim Extensions (Model SFS)	138
Blanks	140
CAT Blanks (ANSI/ASME 5.50-1994)	140
CATP AccuPlus™ Face Contact Blank	140
BT Blanks (MAS 403)	141
BTP AccuPlus™ Face Contact Blank Bars	141
PTI Blanks (ISO 26623-1)	142
KTI Blank Bars (ISO 26622-1)	143
HSK Blanks (DIN 69893-1)	143
Spindle Test Mandrel	144
Test Mandrels CAT/BT/HSK (3 µm / .0001" TIR)	144
Test Mandrels PTI/CATP/BTP (3 µm / .0001" TIR)	145
Test Mandre ER Collet (5 µm/0.000196" TIR)	146
Tool Changer Alignment Tools	147
Quick Change Tapping Systems & Accessories	150
HRF Reversible Tapping Attachments	151
HR Reversible Tapping Attachments	152
SDG Self Opening Die Head	153
Die Holder - Model DH	154
Tap Chuck - Model TK / MT	154
Tap Chuck - Medel TK / JT	155
Tapping Chucks - Tension & Compression Style with High Pressure Coolant-Through-QCLC-IK	156
Modular Shank Holders	156
Tapping Chucks - Rigid Style with Coolant-Through - QCK/IK	157
Tapping Chucks - Tension & Compression Style - Non-Coolant Through - QCLK	158
Tap Adapter Guide	160
Tap Adapters QA Style - ANSI Shank Taps	162
Tap Adapters QA Style - DIN Shank Taps	163
Tap Adapters QA/IK Style -Inch Shank Taps	164
Tap Adapters QA/IK Style - Metric Shank Taps	165

Tap Adapters QA/K Style - Inch Shank Taps	166
Tap Adapters QA/K Style - Metric Shank Taps	167
Tap Adapters QASB Style - Inch Shank Taps	168
Tap Adapters QASB Style - Metric Shank Taps	169
Tap Adapters QASB/K Style - Inch Shank Taps	170
Tap Adapters QASB/K Style- Metric Shank Taps	171
Tap Adapters QASB/IK Style - Inch Shank Taps	172
Tap Adapters QASB/IK Style - Metric Shank Taps	173
Tap Adapters QAN Style - Inch Shank Taps	174
Tap Adapters QAN Style - Metric Shank Taps	175
Tap Adapter QRE Style	176
Adapter QA Jacob Taper Holder	176
Adapter QA Thread Holder	176
Tap Adapter GWA Style Pin Wrench	177
Tap Adapter Sets	177
AccuTap™ ERT/E ER	178
ERT/E ER Quick Change Tap Collets	180
Hardware and Accessories	181
Morse Taper Sockets and Extensions	181
ER Collets- Standard, High Precision, and Sealed Collets - Inch and Metric ID Sizes	182
ER Collet Nuts	184
ER Collet Sets	185
ER-T Collets - Inch Tap Collets for Rigid Tapping - DIN6499/ISO15488	186
Straight Shank - ER Collet Holders	187
Straight Shank - ER Collet Holders-SSH-CHE	189
Reduction Collets for AccuMill™ Multi Milling Chucks and AccuClamp Hydraulic™ Chucks	191
Tool Holder Bushing	193
Retention Knobs	198
HSK Coolant Tubes	200
PTI Coolant Tubes	200
Length Adjustment Screws for ER Collet Chucks	201
“Y” Spanner Wrenches for AccuMill™ Multi-Milling Chucks	201
Torque Wrench for Multi-Milling Chucks	201
Shell Mill Arbor Screws	202
Tool Shank Holding Fixtures	203
ER Nut Wrenches and ERZ Nut Spanner	203
ER Collet Nut Wrench Heads for Interchangeable Torque Wrench	204
HSK Coolant Tube Wrench	204
Torque Wrench for AccuClamp Hydraulic Chuck	204
Spindle Taper Wipers	205

Work Holding	206
DP - Dust Proof - Self Centering Chucks	206
AD - AccuTru™- Self Centering Chucks	206
MTJ - Master & Top Jaw - Self Centering Chucks	207
4 Jaws Independent Chucks - Type IC	208
OCDK - Open Center Direct Mount Power Chuck	209
T-Nuts/Jaw Nuts	210
Jaw Boring Rings	210
Aluminum Pie Jaws - Serrated and Tongue & Groove	211
Serrated Soft Steel Top Jaws With Flat or Pointed Ends	212
Accturn™ Turret Tool Blocks & Accessories	214
BMT-40 Inch & Metric Tool Holders for DMG MORI	214
BMT-60 Inch & Metric Tool Holders for DMG MORI	216
BMT-68 Inch & Metric Tool Holders for MAZAK	218
BOT Inch & Metric Tool Holders for HAAS	219
BMT-65 Inch & Metric Tool Holders for HAAS	221
BMT-45 & BMT-55 Tool Holders for Hardinge	224
BMT-55 Tool Holders for Biglia	225
BOT Tool Holders for Muratec	226
BMT-45 Inch & Metric Tool Holders Multi Brands	227
BMT-55 Inch & Metric Tool Holders Multi Brands	229
BMT-65 Inch & Metric Tool Holders Multi Brands	231
BMT-75 Inch & Metric Tool Holders Multi Brands	233
Taper Shank Standards	234
Tap Standards ANSI / Metric	237

Overview of Products & Technology

Accutek® Offering Overview

Given the constant evolution of tooling and machining technology plus the ever-increasing needs of our customers for greater accuracy and efficiency - Accutek is committed to consistently working on developing innovative products and expanding our product offering to meet our customers' production and manufacturing process needs. The following section highlights the Accutek tooling solutions available.

Standard CNC Tooling Solutions

End Mill, Shell Mill, ER Collet, MT Socket, Jacobs Taper, Straight Shank, and R8 Shank tooling



Technology Tooling Solutions

AccuMill™ Milling Chucks, AccuGrip™ Shrink Fit Chucks, AccuPlus™ Face Contact Chucks, AccuLock™ KTI and PTI Polygon Shank Chucks, AccuTrac™ Threaded Connection Chucks, and AccuClamp™ Hydraulic Chucks



Industry Standard Spindle Connections

DIN, ANSI, BT-MAS, Face Contact, KTI Taper Interface ISO 26622-1 and Polygon Taper Interface ISO26623-1 Shanks



Overview of Products & Technology

Accutek® - Precision manufactured to the global industrial standard specifications and according to ISO 9001-2015 process standards.

Precision and Accuracy as Accutek is Focused on the "Centerline of Performance"

- TIR maintained to 0.0004"
- Balanced to G2.5 @ 25,000 RPM
- Bore tolerance: H6/H7
- Taper-to-Bore runout <0.0002"
- Taper shank ground to AT3 (or better)
- CMM and certified gauge inspection equipment
- All surfaces ground and corrosion resistant oxide coating where required
- All tool holders shipped with Certificate of Balance Accuracy



Quick Change Tapping Systems - AccuTap™







Overview of Products & Technology

AccuMill™ High Performance Milling Chucks

AccuMill™ High Performance Milling Chucks are excellent products for roughing to finishing applications in all types of materials. This Accutek design provides the highest possible tool shank gripping force (torsion) with flexibility of reduction sleeves to allow for multiple cutting tools shank sizes and no loss of TIR. This versatility allows the use of HSS shank tools, solid carbide shank tools, indexable carbide insert tooling, indexable drills, reamers, and many more tools.



Design of the AccuMill™ is unique to Accutek to maximize metal-removal performance while maximizing cutting edge tool life and providing superior part finishes. The AccuMill™ design incorporates an inner chuck body with a needle roller bearing assembly, and a heavy-wall locking nut to create a high torque rate on the tool shank maximizing torsion break-away of the tool shank. There are internal grooves parallel to the axis of the bore to allow maximum gripping force without loss of TIR accuracy. The needle roller bearing cage squeezes the ID bore when the locking nut is rotated clockwise using a specific wrench with a handle length specifically designed to produce the highest torque WITHOUT the need for “hammer” or “cheater bar” to apply additional pressure. There are no threads on the internal connection between the tool body and the locking nut. The special taper design allows the roller bearing cage to move down axially to tighten the ID bore around the tool shank. This locking pressure is distributed 360° around the tool shank and to the entire cylindrical length of the tool shank providing maximum TIR accuracy at 4 x Diameter of the tool shank.

	<p>Key Features of the AccuMill Milling Chuck:</p> <ul style="list-style-type: none">• Individual bearing seats in bearing cage• Strong carbon-steel bearing cage• Internal vertical grooves for accurate ID grinding and “dirt grooves” prevent tool slippage• Positive “stop” to prevent over-torqueing of clamp nut• “O” Ring seals prevent coolant and “swarf” from entering bearing cage area	<p>Benefits of using the AccuMill Milling Chuck:</p> <ul style="list-style-type: none">• Improved TIR results in long cutting-edge tool life• Improved TIR results in better piece part surface finish• Cylindrical gripping and axial forces create a more rigid cutting tool resulting in strong radial load ability• Reduction sleeves offer multiple diameter tool shank flexibility• Increased machining rates due to high accuracy (TIR) and radial load capability	
			

Overview of Products & Technology

AccuMill™ High Performance Milling Chucks

To achieve maximum gripping force on the tool shank, rotate the locking nut clock-wise until the rotation force of “normal” pulling force on the wrench handle is achieved. Once this is achieved back-off the locknut counter clockwise 5°-10° and you are all set to begin machining.

AccuMill™ also includes multiple “O”-Ring seals on the top and bottom of the lock nut to prevent coolant and solutions from entering the bearing cage area for maximum tool usage and minimal maintenance. Should the bearing grease be contaminated during use, the tool can be return for a low-cost refurbishment of the grease.

Why AccuMill vs. TG or ER collet chucks and side lock holders?

- High Quality AT3 steep tapers and DIN Standards HSK tapers
- Uniform gripping pressure 360-degrees around tool shank – ER/TG collets do not provide uniform 360-degree gripping forces and are 70% less in overall gripping torque than AccuMill
- Uniform gripping forces the entire length of tool shank – ER/TG collet chucks as well as side lock holders do not provide uniform tool shank gripping pressure the entire length of the tool shank during heavy radial loads.
- Symmetrical design and balance allow for higher RPM machining applications without vibrations from unbalanced/non-symmetrical tool design.
- Cutting tool shank is held with a cylindrical force and maintains cylindricity which allows excellent TIR at 4 x Dia.

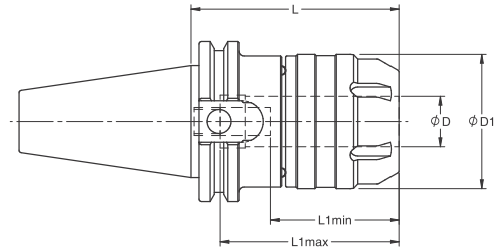

FEATURES

- **Balanced to G2.5 @ 25,000 RPM**
- **T.I.R. < 0.0002"**
- **Taper shank ground to AT3 accuracy (or better)**
- **Bore tolerance: H6**

Proper Care Will Increase AccuMill™ Performance Life

The following simple steps will help maintain maximum operational performance of your AccuMill™ chuck.

- Keep your Milling Chuck clean
 - Debris caught in between the chuck, reduction sleeve, and tool shank can not only reduce chuck life, it can also reduce accuracy and gripping force of the tool shank. Before assembling the tool's shank into the ID bore and/or reduction sleeve bore, make sure the shank and ID bores are free from grease/coolant, chips, and dirt. Clean slots of reduction sleeves with solvent or compressed air.
- Store your Milling Chucks Properly
 - When your milling chuck is not in use, make sure to follow these few guidelines:
 - Loosen the locking nut to relieve pressure on the roller bearing cage
 - Remove reduction sleeves and/or cutting tools from the ID of the milling chuck
 - Wipe Milling Chuck so it is free from coolant and spray with anti-rust solution like WD40™ or LPS 2™
- DO NOT over-tighten your Milling Chuck
 - The design of the AccuMill™ and its roller bearing cage are such that excessive torque from “cheater bars” or “hammering the wrench handle” will over tighten the bearing cage causing ID bore distortion and possible long-term TIR run-out. Only use “Y” Spanner Wrench supplied and use “normal” human pressure to the end of the wrench.

Overview of Products & Technology

Accutek®™ AccuClamp™ Hydraulic Chuck Products

AccuClamp hydraulic chucks are almost unbeatable in their combination of gripping power and TIR accuracy. The AccuClamp design uses our understanding and knowledge to expand steel in a controlled and precise way. We take this knowledge and transform it into our AccuClamp clamping technology.

AccuClamp™ benefits:

- Absolute smooth ID surface
- High Accuracy TIR achieved with high-precision ID grinding operations
- High clamping force is achieved by our unique design of two-part hydraulic clamping system chamber and flexible ID surface. Excellent vibration dampening effects.
- Leak-proof hydraulic clamping screw system for a maintenance-free product
- Accutek torque wrench for proper clamping force without over tightening clamping screw system
- Flexibility due to intermediate coolant-sealed sleeves
- All industry standard shanks can be properly gripped
- ID wiper grooves for debris-free and oil-free cutting tool shanks

AccuClamp™ Applications:

- High-Speed machining and Fine Milling
- Precision Reaming
- Parallel Milling
- Boring & Chamfering
- Tool Grinding
- Precision Workholding

AccuClamp™ Operational system:

- Make sure all surfaces of tool shank, holder ID bore, and reduction sleeve (if being used) are clean and free from oils, chips, etc.
- Open ID bore with a counterclockwise rotation of the clamping screw until cutting tool shank easily slides into ID bore
- Slightly turn the clamping screw clockwise until you feel tension/gripping force on the shank of the cutting tool.
- If the shank can be inserted full depth and still maintain an acceptable gauge length, this is best operational position.
- If cutting tool needs to be moved up slightly to maintain a required gauge length pull cutting shank upward to the desired position (maintaining a minimum of 75% shank engagement in ID).
- Tighten clamping screw by turning clockwise until torque wrench clicks when it reaches proper clamping pressure

AccuClamp™ Maintenance:

- AccuClamp system is basically a maintenance-free product. There are some good housekeeping rules to follow to maximize the quality and performance of this products
- Never over-tighten the clamping screw. Once the AccuClamp torque wrench “clicks” it has reached the required torque and hydraulic pressure to properly grip the cutting tool shank. This practice will always allow proper gripping forces on cutting shank even with the varying shank tolerances.
- Never remove clamp screw from the threaded body it is inserted into. Removal may allow debris in threaded area or in clamping system causing potential damage.
- Never tamper with, remove, or machine oil-fill hole in body of the hydraulic chamber.

The AccuClamp™ Difference

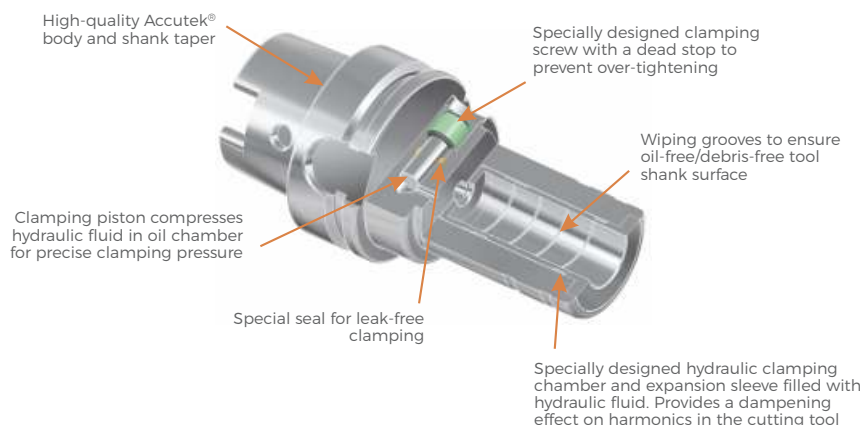

Tool holder Selection Guide

Spindle Selection

What type of spindles are available on machine tools, and which is best for your needs?

Over the past five to six decades, machine tool builders have developed many varied sizes and styles of machine tool tapers to hold the tool holders and cutting tools they want their machines to utilize. They look at multiple factors such as rigidity, RPM/Speed of spindle, size, and overall performance desired between machine control, accuracy of machine, and speed of table/head feed rate.

Over the past three decades, the metal cutting industry has settled on five to six different spindle connections and machine tool builders design their equipment using any one of these taper technologies as it best suits their machine design.

1920s. NMTB - Old technology mainly used on manual equipment and large boring mills where automatic tool changes are not needed.

1980s. CAT40/CAT50 - The ANSI/ASME B5.50 was designed in the early 1980s for use with automatic tool changing systems in machines. This replaced the manual tool changes with automatic tool change arms and tool carousel storage. This steep taper design was produced to help the machine tool builders and the metal working end-users to standardize the spindle connection since many of the machine tool builders in the 1970s and early 1980s had designed their own connection thus making it difficult for the manufacturers to standardize their equipment as they purchased new machines and tooling. The steep taper design allows for more rigid applications when heavy radial loads are part of the machining process. This design has some limitations regarding spindle RPM as high RPM machining tends to cause taper "bell-mouthing" at the spindle's largest opening allowing increased tool TIR growth and loss of machine taper/tool holder taper contact. CAT is a largely a North American spindle connection compared to balance of the world.

1980s. BT30/BT40/BT50 - MAS403 spindle connection. Originally a standard design on all Japanese designed and produced machine tools. It has slightly better "balanced by design" features and the tool change arm allows for faster tool changes between spindle and tool storage system. Uses the same steep taper design that the ANSI/ASME style offers but allows higher spindle RPM due the "balanced by design" flange. Similar performance as the ANSI/ASME style where heavy radial loads are used in many machining processes.

1990s. BT and CAT Face Contact designs, which were developed by Daishowa Seiki Co. in 1994 under US Patent 5352073, took the benefits of the MAS403 and ANSI/ASME designs but removed the "weakness"



01



02



03

Tool holder Selection Guide

from higher RPM machining by utilizing a face contact between the flange of the tool holder and the spindle face of the machine tool spindle. This additional contact surface allows more rigidity because of the larger “footprint” the spindle face contact offers. This large diameter of contacts increases the “leverage point” between spindle taper, spindle face, tool taper, and tool flange face. Excellent design where long-length tools and/or large diameter tools benefit from additional tool/taper contact for accuracy and rigidity. While this design is like the BT-MAS and CAT-ANSI, interchanging styles of tapers in a face contact spindle is not recommended. Accutek follows the expired US Patent 5352073 to maintain the integrity of the design as our AccuPlus™ product.

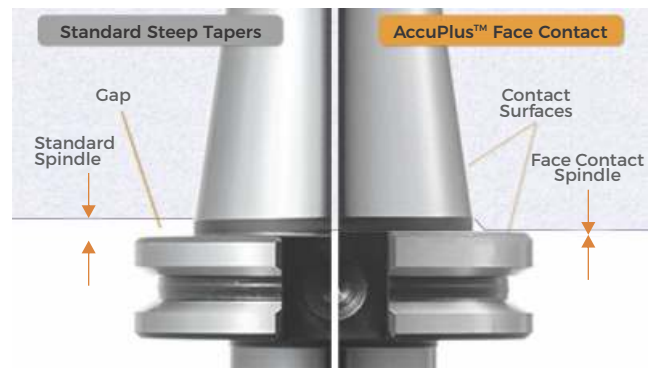

(Note: Not all "Dual Contact" shank holders conform to BigPlus Patented dimensions)

04

1990s. HSK - DIN 69893 A, C, E, and F styles - HSK means “hollow shank” and uses a drawbar that pulls the taper into the machine using internal gripping vs. the external drawbar gripping that steep taper designs use with a retention knob. While this is a spindle connection for metal working machines like the steep taper designs, this design allows for much higher spindle RPM machining because of the spindle/drawbar, and connection design. The “low profile design” and balanced orientation slots allows for a much higher spindle RPM without the spindle opening “bell-mouthing” seen in the steep taper designs. HSK also uses the face contact to increase tool holder rigidity for radial loads. HSK does require a change in “machine programming culture”. With ANSI and MAS403 designs, heavy radial loads at lower spindle RPMs is the normal practice. With the HSK shank such heavy radial loads are handled differently by increasing spindle RPM, lighter chip loads on cutting tools, and an overall increase in machining metal removal rates. By reducing chip load and increasing spindle RPM, most of the “heat” created during the machining process goes with the chip/swarf and not into the cutting tool or work piece material. Better tool life, better work piece accuracy, and better part finishes can be achieved using HSK spindle technology over steep taper designs. As HSK spindle RPM increases, HSK shank tooling tapers and diameters can “shrink” in sizes to better match the machining processes and high spindle RPM demands for high tool assembly balance needs. HSK shanks are available in sizes 20 taper through 125 (number indicates OD size of flange diameter). Styles of flanges can also be changed to increase balance of holder by changing from “A” or “C” styles to “E” or “F” styles.



05

1990s. In the mid-1990s the new machine technology was the Multi-Tasking machining center or the Mill-Turn machining centers. This new machining technology required a spindle connection that not only could rotate for rotational machining applications like milling, drilling, tapping, etc. but also maintain a static or stationary position for turning - thus the multi-tasking or mill-turn names. Rotational tool machining presents a specific set of forces that static or stationary turning does not present. Conversely, static or stationary turning presents machining forces not seen in rotation tooling applications. This required new spindle connect designs to allow the “complete” machining process with a single style tool holder and machine connection. After several attempts by cutting tool manufacturers to develop the “best” spindle/tool holder interface that performs well in both rotating and static applications, two designs have become the primary choices by machine tool builders and metal working customers - ISO 26622-1 KM®

Tool holder Selection Guide

tool shank and ISO26623-1 CAPTO®¹ shank. The KM®² shank was an original design by Kennametal Inc. and CAPTO® was an original design by Sandvik Coromant. Both designs achieve the desired results of rigidity, quick tool changes, accuracy, and strength in static operations and rotational operations. The style preference is up to the individual's comfort.



ISO26623-1



ISO26622-1

Determining your spindle connection for your next machine tool purchase depends on your comfort level with new spindle technology, need for increased machining capabilities, and type of work you plan to process through the new machine. While there are advantages with Steep Taper designs as well as HSK Taper designs, you will need to match those advantages to your specific machining needs. Most important fact about spindle and tool connection selection – TIR (Total Indicator Runout) is the primary consideration. Quality, price, and accuracy of the tool holder are all considerations, but for every .0001 of TIR away from the tool assembly centerline, 10% of your cutting tool life is lost due to uneven cutting tool edge material loads. TIR can be measured where the cutting tool shank and tool holder meet but the true assembly TIR should be measured at the tip of the cutting tool where the dimensional accuracy of your tool assembly and cutting parameters are determined.

Note : *KM63xMZ does not follow the ISO26622-1 standard and is a slight variation of the design specifically for Mazak Integrex machines. Make sure when ordering KTI shank tools you know whether your connection is KM63XMZ or KM63TS.

Tool Clamping Technology and Selection

Which tool clamping or tool holding system is your best overall value for your machining processes?

When it comes to selecting the proper or the “best value” tool clamping system for your machining applications, you must first look at the type and size of cutting tools you want or need to use. The following factors will all have an impact on steering the decision for the most appropriate technology for your application:

1. Shank styles and sizes
2. Shank types – HSS / Tool Steel or Carbide
3. Material you will be machining and whether roughing, semi-roughing/semi-finishing, or finishing
4. Length of surface to be machined with regards to radial load on the cutting tool
5. Metal-removal rates - Aggressive or more “normal”
6. Spindle RPM capability and Spindle type – HSK, Steep-Taper, Steep-Taper with Face Contact, or Multi tasking tapers like CAPTO® or KM®, and finally
7. Budgetary constraints – how much are you able or willing to spend for a tool clamping system

With regards to the last item, it is important to recognize that cost of a tooling system is not the same as the Total Cost of Ownership (TCO). The often-overlooked component of the cost of the tool life lost due to excessive runout can have a big impact on the long term financial calculations:

Total Cost of Ownership = Tooling System Cost + Tool Life Loss Selection

Example 1: CAT40 End Mill Holder with Solid Carbide four flute ½” end mill:

Tooling System Cost = \$100.00 (holder) + \$50.00 (endmill) = \$150.00

Tool Life Loss = 0.6 (average TIR of 0.0006 = 60% reduction of tool life) x \$50.00 = \$30.00.

Total Cost of Ownership = TSC + TLL = \$150 + \$30.00 = \$180.00

¹ CAPTO is a registered trademark of Sandvik Intellectual Property AB

² KM is a registered trademark of Kennametal Inc.

Tool holder Selection Guide

This means you need to add an additional \$30.00 to your total tooling cost to account for the reduced life you'll get because of the runout associated with a standard endmill holder.

Example 2: CAT40 ER32 Collet Chuck with the same four-flute, ½” end mill:

Tooling System Cost = \$180.00 (holder) + \$50.00 (endmill) = \$230.00

Tool Life Loss = 0.4 (average TIR of 0.0004 = 40% reduction of tool life) x \$50.00 = \$20.00.

Total Cost of Ownership = TSC + TLL = \$230 + \$20.00 = \$250.00

The TCO concept becomes far more important when we consider a longer production run since the TLL will overshadow the initial TSC.

Tool Clamping System	Tool Holder Cost \$	Cutting Tool Cost	Tool Life Loss (per cutting tool)	# of Cutting Tools Used	Total Cost of Ownership
CAT40 End Mill Holder	\$100.00	\$50.00	\$30.00 (60% loss)	10 endmills	\$900.00
CAT40 ER32 Holder	\$180.00	\$50.00	\$20.00 (40% loss)	10 endmills	\$880.00
CAT40 AccuMill™	\$350.00	\$50.00	\$10.00 (20% loss)	10 endmills	\$950.00*
CAT40 AccuGrip™	\$220.00	\$50.00	\$5.00 (10% loss)	10 endmills	\$770.00**

* Actual TCO is better due to improved metal removal and higher productivity rates

** TCO is lower, but additional cost of the shrink fit machine needs to be factored in

From these examples, we can see that the cost of a tool holder is only part of the total cost of ownership associated with a tool holding solution, therefore one must look at the total machining processes to determine which tool clamping system is the best value for each application. TIR of your tool clamping system will play a significant role minimizing the TCO.

The following table summarizes how various tool holder clamping systems compare against each other:

	END MILL HOLDER	ER COLLET CHUCK	HIGH PRECISION COLLECT CHUCK	MILLING CHUCK	HYDRAULIC CHUCK	SHRINK FIT HOLDER
TIR ACCURACY						
VERSATILITY						
RIGIDITY						
EASE OF USE						
PRECISION RELIABILITY						
BALANCE						
COST \$						

	POOR		FAIR		AVERAGE		GOOD		GREAT
--	------	--	------	--	---------	--	------	--	-------

For more details when selecting a Tool Clamping System, please refer to our Accutek Tool Selection Guide at the back of the catalog.

Tool holder Selection Guide

AccuPlus™ Steep-Taper Face-Contact Chucks Technical Features



AccuPlus™ Steep-Taper Face-Contact Technical Data



Taper and face contact result in greater tool holder stiffness



Compatible with BIG-PLUS © spindles and standard spindles



Primary Applications

- Face-Contact tapers provide additional radial load capabilities due to the large spindle contact surface compared with standard ANSI B5.50 or MAS BT 403 tapers.
- Excellent for long-reach axial cutting tools where cutting tool tip TIR is critical for part dimension achievement and machined surface location/
- With the wide face-contact longer axial cutting tools with high radial loads will have less “bending” or improved dynamic stiffness and rigidity. The vibration dampening of these holders reduces spindle wear and extends cutting tool life.
- Designed for use in CNC Machining Centers with Face Contact spindles and automatic tool changers

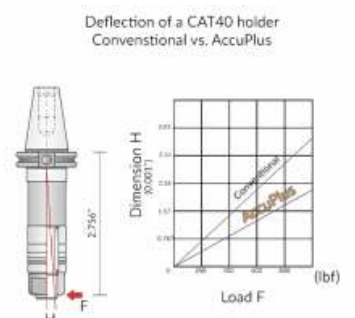
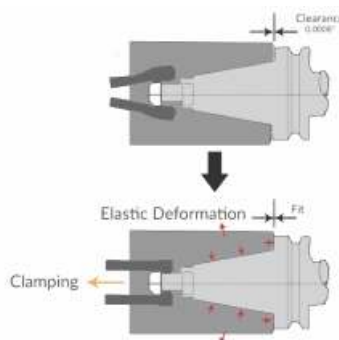
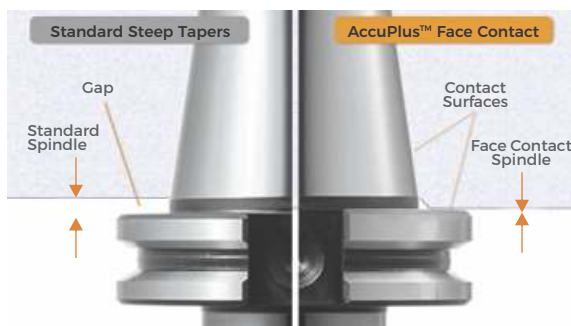

Tool holder Selection Guide

Principle Behind Face-Contact Technology

- Prior to spindle clamping, the tool taper and spindle are in contact with each other to establish good taper interface and once clamped, face contact is made because the elastic deformation of the spindle clamping system provides the proper face clamping force between spindle face and tool holder flange face.
- This simultaneous fit provides a strong spindle/tool shank connection for more accurate machining possess and increased tool life due to improved tool assembly (spindle-toolholder-cutting tool)
- Face Contact holders are universally suitable for Drilling, Face milling, End mill with radial loads, Reaming, and even grinding is machine control is capable. The vibration dampening of this face contact system reduces spindle wear and extends cutting tool life.

Important Note about AccuPlus™ and other face contact steep taper tools:

If machine has standard face contact spindle design and face contact holders are to be used, ALL tool holders should be face contact style. Do not inter-mix standard steep taper holders with face contact holders for use in same machine spindle. Face contact holders must maintain contact with spindle face surface to maintain accuracy and proper toolholder shank/machine tool spindle taper interface. Using standard steep taper tools will allow chips, swarf, and residue to collet on the face when face contact is not being maintained thus using a face contact tool holder after using a standard steep taper tool could allow the face of the spindle to have contamination between spindle face and face contact of tool holder causing damage to spindle face and/or face contact holder. Start with AccuPlus™ and face contact and stay with it for ALL tool holder style in that machine.

(Note: Not all "Dual Contact" shank holders conform to BigPlus Patented dimensions)

Tool holder Selection Guide

Balancing Guide

Accutek Balancing Methodology

Accutek's high quality and high precision tool clamping products conform to the latest ISO/DIN balancing specifications. In this section, you will find a copy of an actual balance specification sheet supplied with each Accutek rotating product to show exact balancing dynamics of the product purchased. Before we dive into the specifics of our holder balancing certificate, let's cover some theoretical and practical factors that govern the balancing framework that we follow.

Proven Theory of ISO/DIN 1940-1 and ISO/DIN 1940-2 Balancing specifications

The balance of a rotating tool clamping product is critical to machine spindle wear and cutting tool performance, but how perfect does the balancing need to be? To answer that, we must first look at what imbalance is and how it impacts a holder.

Imbalance Before Corrective Action

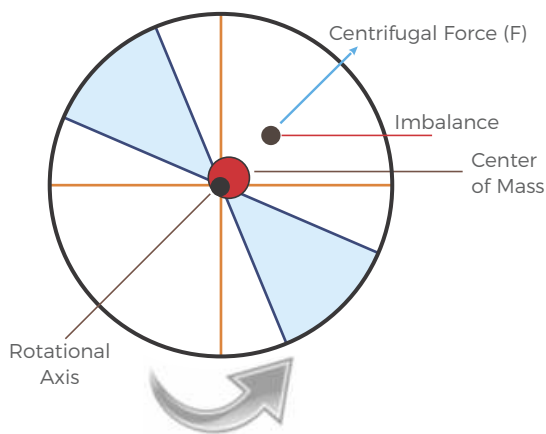

Corrective Action

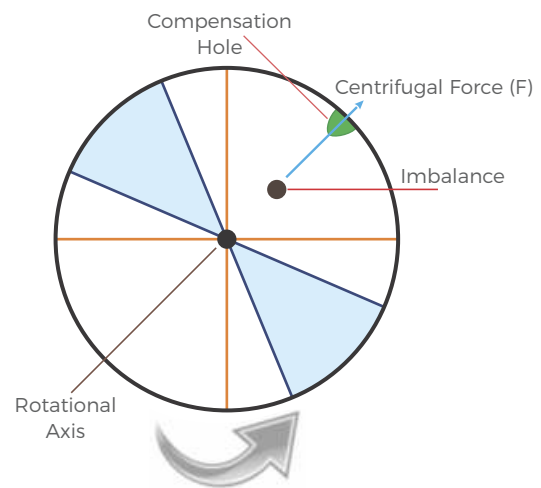

Imbalance - an unbalanced tool holder (one which has its center of mass away from its rotational axis) produces a centrifugal force at the rotation spindle, impeding efficient operation of a cutting tool. Imbalance also has a negative effect on machine spindle bearings lifespan and cutting tool performance. As in the figure above, corrective action of material removal (compensation hole) rebalances the holder and brings the center of mass back in alignment with the rotational axis.

Balanced With Corrective Action

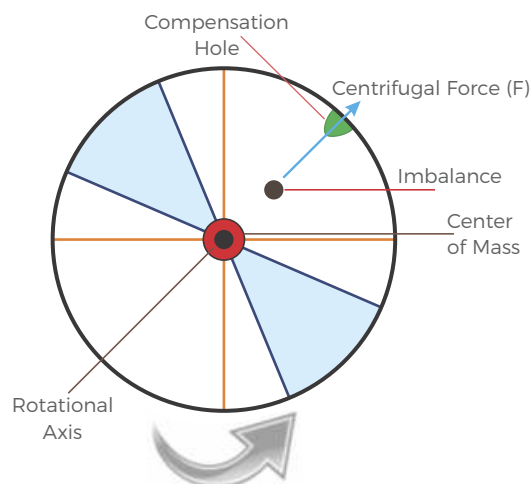

Tool holder Selection Guide

Balancing Guide

At Accutek, we balance our general purpose holders to a realistic G2.5 @25,000 RPM specification designated by ISO/DIN 1940-2. For most tool holders, any higher degree of balancing is impractical and misleading since the percentage of error increases and the practical application requires rebalancing of every tool assembly to maintain the higher standard. For example, an ER Collet holder balanced to G2.5 will not remain balanced once a retention knob, collet, and cutting tool have been installed. Multiple studies have proven that G2.5 balance levels cannot be maintained on steep taper and HSK taper CNC holders (End mill, Shell mill, ER collet chucks, etc.). The following variances create a high degree of imbalance that makes G2.5 a false rating and misrepresentation of actual repetitive tool assembly balance:

Product	Causes of imbalance in assembly of tool after established G rating Balance					
	Pre-Balance	Retention Knobs	Collets	Collet Nut/Torque	Locking Screw	Arbor Screw
ER COLLET CHUKS	Balancing with Collet Nut and Gauge Pin	✓	✓	✓	-	-
END MILL HOLDERS	Balancing with Gauge pin	✓	-	-	✓	-
SHELL MILL HOLDERS	Balancing with Arbor Screw	✓	-	-	-	✓
SHRINK FIT HOLDERS	*	✓	-	-	-	-
HYDRAULIC HOLDERS	Balancing with Gauge pin	✓	-	-	-	-
Steep Taper Tools						

Higher balance rating on AccuGrip Shrink Fit holders and AccuClamp Hydraulic Holders of G2.5 @25,000 RPM is achievable and maintained because there are limited mechanically moving parts to cause variances other than the retention knob. To mitigate any impact of the retention knob installation, all of our holders come with a ground pilot ID for the retention knob pilot location accuracy.

Accutek balancing methodology ensures performance balance of G2.5 @ 25,000 RPM on all CNC holders and G2.5 @ 25,000 RPM on all AccuGrip shrink fit and AccuClamp Hydraulic holders.

All Accutek rotation products are balanced with certified test gauge pins and collets to maintain a consistent accuracy reading. All rotating products are balanced in an “assembly” mode – meaning gauge pin and lock screw or gauge pin and ER collet with specific torque ratings to provide accurate and consistent measurements in accordance with ISO/DIN 1940-2 specifications.

Our toolholders bodies are balanced to G2.5@25,000 RPM as well as our ER collet nuts are pre-balanced to G2.5@25,000 RPM, We then assemble the entire toolholder including collet and gauge pin and then assembly is

Tool holder Selection Guide

Balancing Guide

DIN ISO 1940 Teil 1 Seite 7

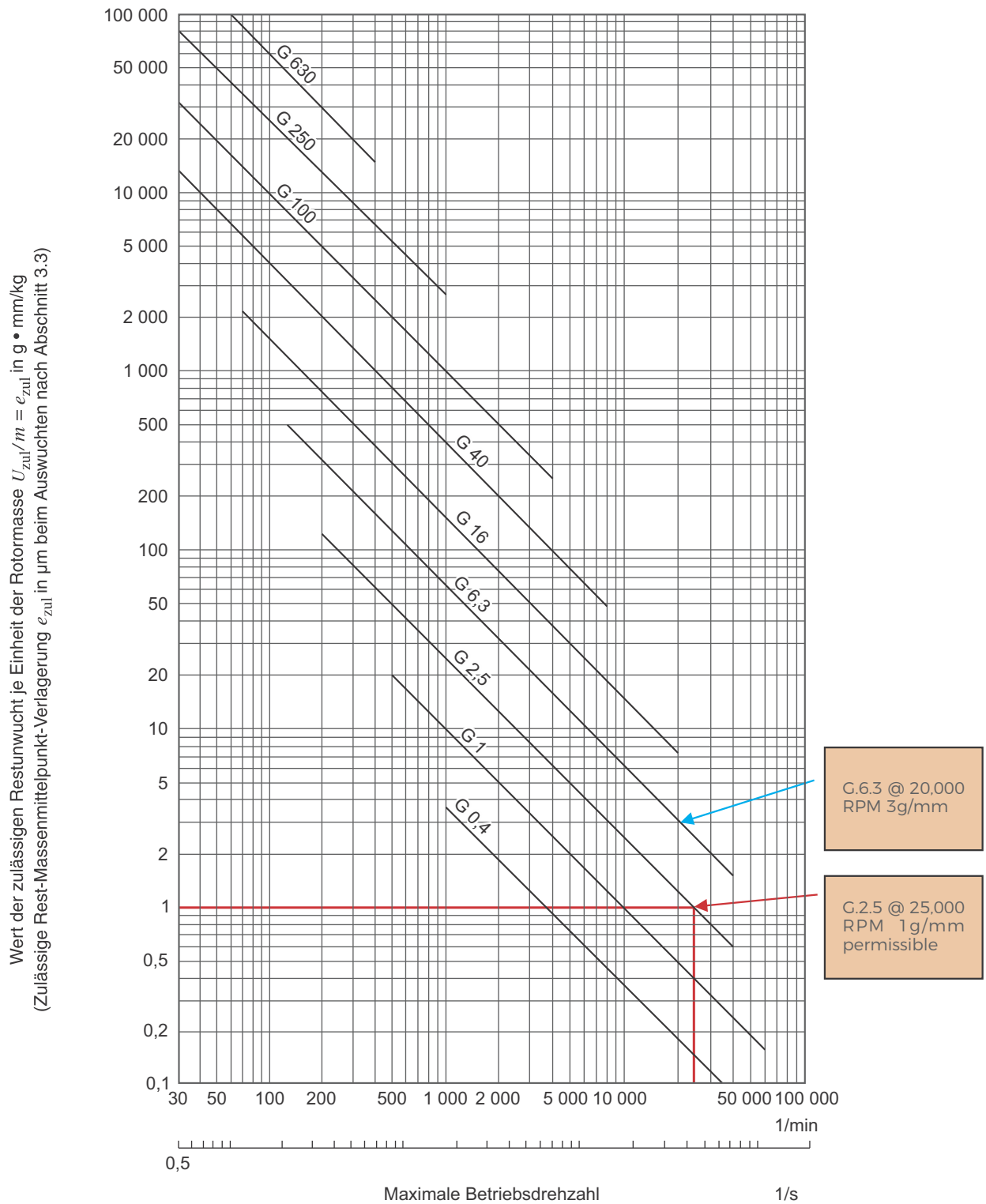

ANMERKUNG: Der Zahlenwert hinter dem Buchstaben G ist gleich dem Produkt $e_{zul} \cdot \omega$, angegeben in mm/s

Bild 2 : Wert der maximal zulässigen spezifischen Restunwucht entsprechend verschiedener Auswucht-Gütestufen

Tool holder Selection Guide

Balancing Guide

Calculations of Balancing Grade Totals - Assembly: Spindle - Tool Holder - Cutting Tool

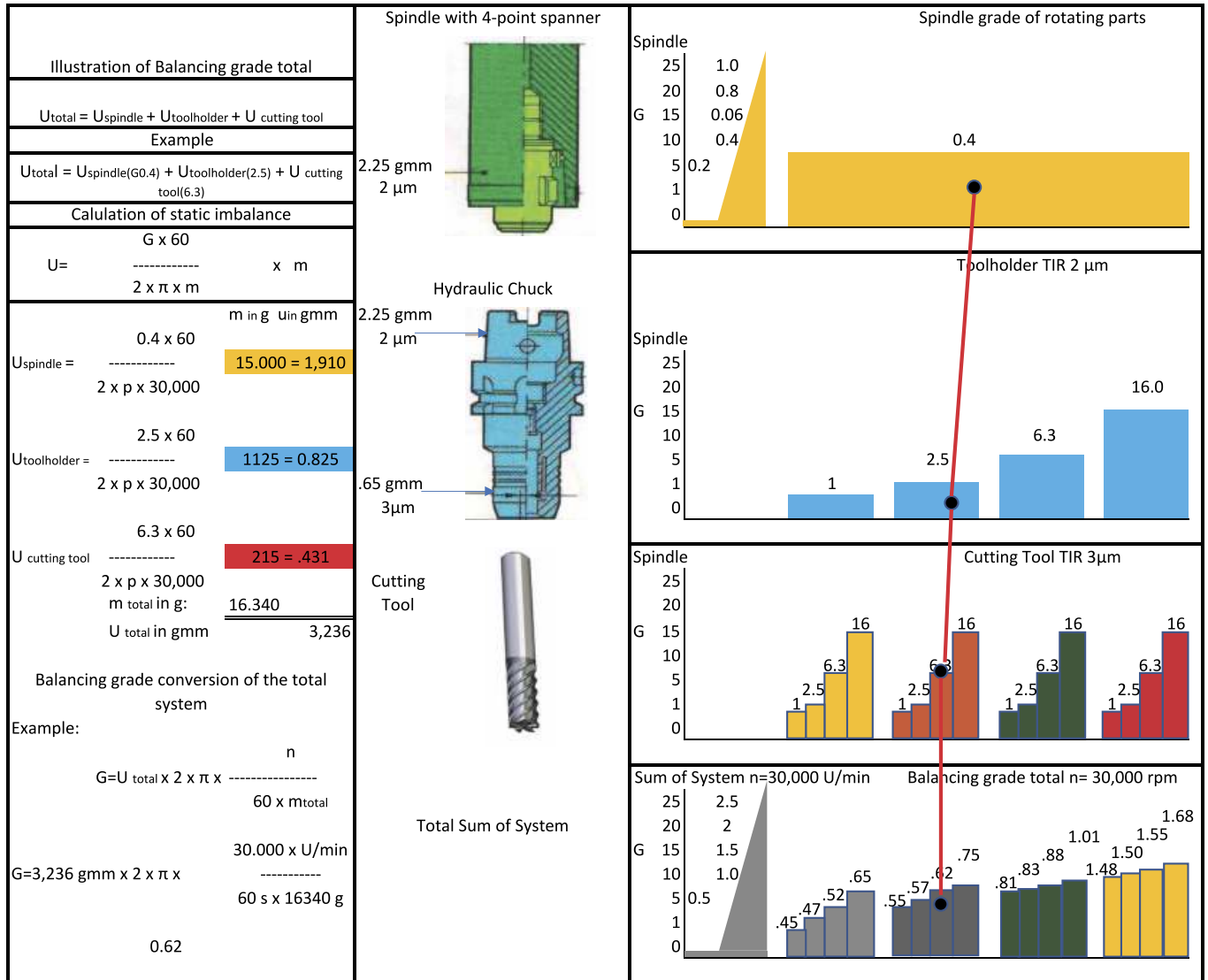

Tool holder Selection Guide

Balancing Guide

Balancing report

Rotor ID R008061

Type data

Rotor type HSK100A CHE 20-6.00 ← Specific Tool Holder
Last change 08/07/2018 13.58 ← Date & Time that balancing was performed
Set speed 1200 rpm (Direction of Rotation: Forward)

ABC geometry

Radius 1 46.0 mm

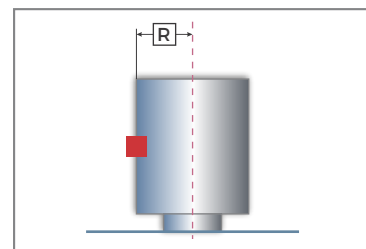

DIN ISO 21940-11 calculation

Calculation based on Quality grade G
Deviation (+/-)% 10 ← Permissible error
Balancing quality grade G 2,5 ← "G" Grade
Mass of rotor 2.75 kg
Service speed 25000 rpm ← RPM balance target
Permissible unbalance 2.9 g·mm ← Permissible Imbalance

Individual index compensation

08/07/2018/14:22:12

Run Rotor 0° mounted at machine position 180.0°
Measuring speed 1081 rpm

Unbalance

Static 139 g·mm 119.6° ← Initial Imbalance

Measuring Results, Run: 3

06/07/2018/14:23:40

Active compensations Indexing
Measuring speed 1081 rpm

Unbalance

Static 2.67 g·mm 329.5° ← Post-Correction Imbalance

Correction

Correction Plane 1 - Drilling 0.926 mm 329.5° ← Correction Detail

Date

Signature

Stamp

Accutek Diebold Product Offer Overview

Diebold CentroGrip®



The Diebold CentroGrip® Collet Chuck System is an ER collet system with much higher accuracy than the standard tool holders with ER collets and nuts.

CentroGrip® collet holders have a runout between tool taper and collet taper of less than one micron. This accuracy is required for many milling processes in high-speed machining. Micro production, medical industry, and aerospace industry. Now users of CentroGrip® holders can machine mirror like surfaces with milling cutters. The advantage of the CentroGrip® Collet Chuck is better runout even at remarkably high speeds and unbalanced level is lower.

Diebold CentroGrip® collet holders are versatile with easy handling. One ER size can accept up to twelve different collet diameters. The runout of the cutter at #xD is less than 3 micron (.0001") which is a crucial factor in high precision machining.

Diebold UltraGrip Power Chucks® 3.0



High Power Chuck for Heavy Milling

Diebold UltraGrip Power Chucks® are specially designed for extreme cutting operations with big milling cutters and high cutting forces. Diebold UltraGrip Power Chucks supply extremely high clamping forces and high vibration dampening due to their design. Low runout combined with extremely high clamping forces are unique. Diebold UltraGrip Power Chuck allows HPC milling with big cutters, high cutting depths, and high feed rates.

Diebold UltraJet® Power Chucks®



High Power Chuck for Heavy Milling with Coolant Nozzles

NEW!!! Diebold UltraJet® Power Chuck is an innovative combination of the JetSleeve® 2.0 technology, which has been established on the market for several years and Diebold's UltraGrip® Power Chuck 3.0.

When using the novel UltraJet® 3.0 it is almost impossible to overrun the chips in heavy-duty machining, resulting in even higher cutting values and significantly longer tool life. That saves money.

The coolant supply is channeled through the UltraJet 3.0 receptacle at high pressure and fed to the cutting tool through the ingenious nozzle assembly. The Venturi effect keeps the mixture independent of the speed at the cutting edge. This ensures optimal cooling and effectively washes away the resulting chips in milliseconds. This function is just as suitable for dry machining with air. The processing of deep holes and cavities is thus facilitated. No toll with internal cooling is needed. Thus, the lower cost tools with much more stable cutting edges can be used.

Diebold Thermo-ER Shrink Collets



Collet chucks use slotted collets for clamping of cutting tool shanks. These collets are flexible but also collet coolant, chips, and dirt. This has a negative effect on run-out and gripping force of cutting tool shank. The result is a loss of precision and higher wear of cutting tool, eventually damaging the work pieces. This results in higher manufacturing costs and lost up-time.

With the innovation of the Thermo-ER Shrink collets, it is possible to improve the ER system significantly. TER Shrink collets are mono-block holders, they have no slots. With a shrink process that cutting tool will clamp in the collet with an additional advantage, the cutting tool can be preset to a desired length. Gripping forces are extremely high and supply much higher torque rates than slotted collets. TER Shrink collets supply much higher runout accuracy allowing use in high-speed milling and micro production.

Accutek Diebold Product Offer Overview

Diebold Modular System – DMS



The new Diebold Modular System (DMS) consists of a base adapter (holder) and inserts of various lengths and body diameters.

When using DMS, the number of tool holders used in production can be significantly reduced with this flexible system. The modular system allows variations of the ID diameters and projection lengths. Flexible change of the “A” – Length dimension is possible without the need of a separate base holder. Total investment will be low, highest TIR accuracy and run out will be achieved.

With this modular system, due to the multi-part design, the advantages of shrink fit technology with precise run out of the tool shaft combined with the high damping capability allow high performance milling operations at high speeds. MDS tool holders have excellent vibration-dampening compared to single-piece shrink holders.

Die and Mold Industry will benefit by improving their cutting performance. Due to slim contour, collisions with work piece are prevented. Machining of deep pockets and cavities is much easier. It is also possible to use cutting tools with internal cooling

The modularity of the DMS gives maximum flexibility. A run out accuracy of less than 3 micron/.0001” is maintained, a crucial factor in high-precision machining.

Diebold UB30 Universal Balancer



The High-precision balancing of tools and tool holders capacity of the machines tool with regards to speed, cutting volume and surface quality. Balancing provides for lower vibrations. It reduces wear of the spindle and tool, reduces downtimes, and increases process security.

The spindle speeds of modern machine tools have increased in the last few years in order to achieve higher cutting volumes and machine profitability manner. The speed increases have also raised the demands for the tools and holders used, because the higher spindle speeds make the effects of imbalance increasingly more noticeable. The consequences are vibrations, bad surface finish and shorter tool life.

Diebold Pull Force Gauges



Clamping force testers are safety-relevant measuring devices.

The Diebold Pull Force Gauges are built purely mechanically and therefore they are independent from the ambient temperature. This is particularly important for service engineers when they are traveling. They can use the Pull Force Gauges immediately, even when removed from the warm or cold vehicle. Just set the dial indicator to zero and you can read the pull-in force in kN of the drawbar with an accuracy of $\pm 3\%$.

Diebold 3D Eco Edge Finder



Diebold 3D Edge Finder Eco is used to precisely search for and set workpiece reference points in all 3 axes. The 3Deco is a compression-type edge finder in which the dial gauge and the feeler mechanism are protected from damage, even if a workpiece is accidentally run over. The buttons have a predetermined breaking point in our design. The 3Deco is a very precise and versatile measuring instrument for milling and EDM machines.

The 3Deco is clamped into a tool holder and inserted into a milling spindle. Once clamped into the machine spindle, the run-out (T.I.R) is fully adjustable to Zero. Then, you can find exact positioning of the spindle axis on the edges of the workpiece. This allows for zeros to be set and the length to be measured quickly and easily. You may approach in any direction (X-, Y-, Z- axis).

Only the 3Deco allows for the edge to be found on the first attempt. No calculating of the probe's ball diameter is necessary. Problems with mathematics or calculations are eliminated, allowing for fewer operator errors. The 3Deco is quick and easy, reducing the extra time needed with most edge-finders, increasing the productivity and accuracy of the operator.

Accutek Diebold Product Offer Overview

Diebold JetSleeve® 2.0

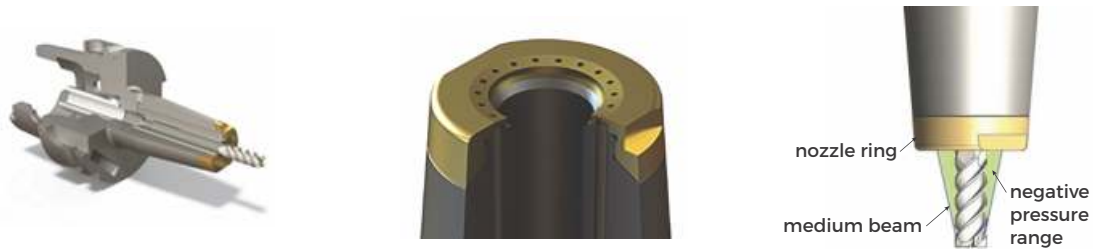

In 2015, Diebold engineers successfully developed the JetSleeve design at a new level of performance. The innovative design, JetSleeve 2.0 features shrink fit technology with micro coolant holes in a Goldring nozzle tip that remains on the holder during the shrinking process. The tiny nozzle holes incorporated in the Goldring tip allow air-oil, coolant, or only air to be sprayed to the tip of the cutting tool at high pressure due to the patented design of the nozzle ring. When using JetSleeve 2.0, chips are immediately blown/flushed away from the cutter area even in difficult-to-process deep cavities. Now the cutter damage by overrunning chips is impossible. This increases tool life by 100%-300% and frequent start of the CNC programs, as required otherwise after changes in no longer required. Now, with the extra insurance "lights-out" production is truly possible. The nozzles will not wear out, they will keep their correct size, and the angle of attack of the coolant will not change. JetSleeve 2.0 assures you that all workpieces can be milled completely in one operation. Many contours can be finished on the milling machines without the need for frequent "chip removal program stops." JetSleeve 2.0 can be used in heavy-duty machining, standard milling, and micro-machining processes.



Diebold Gauging Products

Taper Measuring Equipment

In order to be able to produce parts with tightest tolerances, tool holders of a milling machine must work absolutely correct.

Several factors are influencing the accuracy during machining:

- Spindle taper shows damage, fretting corrosion or marks
- Tool holders show corrosion or imprints
- Reduced clamping force of the spindle retention
- System vibrations arise during processing

These problems occur due to inaccurate tool holders. For this reason, tool tapers should be measured periodically and holders that are not in tolerance according to DIN/ISO standards should be discarded.

Diebold offers various measuring instruments to inspect tool holder tapers and spindle tapers.

- Taper gauges to inspect HSK tapers and their inner contour plus runout testing of the bore for the cutter. Taper gauges to inspect SK, BT and BT tapers with face contact (D-BT)
- Runout test bars: precision gauges for spindle runout testing and test of the alignment of machines
- Pull force gauges: retention force testers are used to check the pull force of clamping systems in machine spindles
- Special taper gauges: gauges for tapers with face contact for all types of modular clamping systems, cutter adapters or special applications



CAT Holders

CAT40 End Mill Holder (ANSI/ASME B5.50-1994)

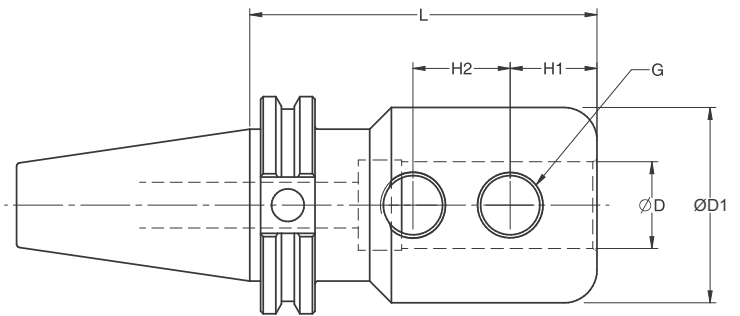

FEATURES

- Balanced to G2.5 @ 25,000 RPM
- Taper shank ground to AT3 accuracy (or better)
- T.I.R. < 0.0004"
- Bore tolerance: H6

Catalog Number	Description	ØD (inch)	L (inch)	ØD1 (inch)	H1	H2	G	Coolant Style
84240712	CAT40-EMH 0.125-2.38	0.125	2.38	0.50	0.22	-	#10-32	AD Thru
84240913	CAT40-EMH 0.187-2.50	0.187	2.50	0.69	0.56	-	#10-32	AD Thru
84240915	CAT40-EMH 0.187-3.00	0.187	3.00	0.69	0.56	-	#10-32	AD Thru
84241113	CAT40-EMH 0.250-2.50	0.250	2.50	0.69	0.56	-	1/4"-28	AD Thru
84241120	CAT40-EMH 0.250-4.00	0.250	4.00	0.69	0.56	-	1/4"-28	AD Thru
84241313	CAT40-EMH 0.312-2.50	0.312	2.50	1.00	0.75	-	1/4"-28	AD Thru
84242613	CAT40-EMH 0.375-2.50	0.375	2.50	1.00	0.75	-	3/8"-24	AD Thru
84242620	CAT40-EMH 0.375-4.00	0.375	4.00	1.00	0.75	-	3/8"-24	AD Thru
84242713	CAT40-EMH 0.4375-2.50	0.4375	2.50	1.38	0.88	-	7/16"-20	AD Thru
84241509	CAT40-EMH 0.500-1.75	0.500	1.75	1.75	0.88	-	7/16"-20	AD Thru
84241513	CAT40-EMH 0.500-2.50	0.500	2.50	1.25	0.88	-	7/16"-20	AD Thru
84241523	CAT40-EMH 0.500-4.62	0.500	4.62	1.25	0.88	-	7/16"-20	AD Thru
84241534	CAT40-EMH 0.500-6.62	0.500	6.62	1.25	0.88	-	7/16"-20	AD Thru
84243315	CAT40-EMH 0.5625-3.00	0.5625	3.00	1.62	0.94	-	9/16"-18	AD Thru
84241709	CAT40-EMH 0.625-1.75	0.625	1.75	1.75	0.94	-	9/16"-18	AD Thru
84241715	CAT40-EMH 0.625-3.00	0.625	3.00	1.62	0.94	-	9/16"-18	AD Thru
84241719	CAT40-EMH 0.625-3.75	0.625	3.75	1.62	0.94	-	9/16"-18	AD Thru
84241729	CAT40-EMH 0.625-5.75	0.625	5.75	1.62	0.94	-	9/16"-18	AD Thru
84242809	CAT40-EMH 0.750-1.75	0.750	1.75	1.75	1.00	-	5/8"-18	AD Thru
84242815	CAT40-EMH 0.750-3.00	0.750	3.00	1.75	1.00	-	5/8"-18	AD Thru
84242819	CAT40-EMH 0.750-3.75	0.750	3.75	1.75	1.00	-	5/8"-18	AD Thru
84242829	CAT40-EMH 0.750-5.75	0.750	5.75	1.75	1.00	-	5/8"-18	AD Thru
84241918	CAT40-EMH 0.875-3.50	0.875	3.50	1.75	1.00	-	5/8"-18	AD Thru
84241929	CAT40-EMH 0.875-5.75	0.875	5.75	2.00	1.00	0.81	5/8"-18*	AD Thru
84242109	CAT40-EMH 1.000-1.75	1.000	1.75	1.75	1.12	-	5/8"-18	AD Thru
84242115	CAT40-EMH 1.000-3.00	1.000	3.00	1.95	0.88	1.00	5/8"-18*	AD Thru
84242120	CAT40-EMH 1.000-4.00	1.000	4.00	2.25	1.00	1.12	3/4"-16*	AD Thru
84242130	CAT40-EMH 1.000-6.00	1.000	6.00	2.25	1.12	1.12	3/4"-16*	AD Thru
84242210	CAT40-EMH 1.250-2.00	1.250	2.00	2.25	1.12	-	5/8"-18	AD Thru
84242222	CAT40-EMH 1.250-4.25	1.250	4.25	2.50	1.00	1.12	3/4"-16*	AD Thru
84242230	CAT40-EMH 1.250-6.00	1.250	6.00	2.50	1.00	1.12	3/4"-16*	AD Thru
84242323	CAT40-EMH 1.500-4.62	1.500	4.62	2.75	1.12	1.00	3/4"-16*	AD Thru
84242330	CAT40-EMH 1.500-6.00	1.500	6.00	2.75	1.12	1.00	3/4"-16*	AD Thru

Retention knobs on page 198-199

CAT Holders

CAT40 End Mill Holder (ANSI/ASME B5.50-1994)

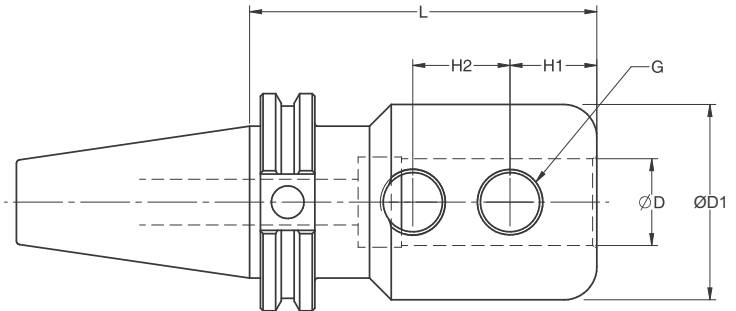

FEATURES

- Balanced to G2.5 @ 25,000 RPM
- T.I.R. < 0.0004"
- Taper shank ground to AT3 accuracy (or better)
- Bore tolerance: H6

Catalog Number	Description	ØD (mm)	L (mm)	ØD1 (mm)	H1	H2	G	Coolant Style
84240312	CAT40-EMH 3-60	3	60	12.70	5.30	-	M3x0.7	AD Thru
84240415	CAT40-EMH 4-75	4	75	17.50	14.2	-	#10-32	AD Thru
84240515	CAT40-EMH 5-75	5	75	20	16	-	M6x1	AD Thru
84240612	CAT40-EMH 6-60	6	60	25	18	-	M6x1	AD Thru
84240815	CAT40-EMH 8-75	8	75	28	18	-	M8x1.25	AD Thru
84241015	CAT40-EMH 10-75	10	75	35	20	-	M10x1.5	AD Thru
84241215	CAT40-EMH 12-75	12	75	42	22.5	-	M12x1.75	AD Thru
84241609	CAT40-EMH 16-45	16	45	44.45	33.9	-	M14x2	AD Thru
84242015	CAT40-EMH 20-75	20	75	42.90	25	-	M16x2	AD Thru
84242516	CAT40-EMH 25-80	25	80	50	24	-	M18x2	AD Thru
84242530	CAT40-EMH 25-6.00	25	152.4	63	24	25	M18x2	AD Thru
84243210	CAT40-EMH 32-50	32	50	57.15	24	-	M14x2	AD Thru

Retention knobs on page 198-199

CAT Holders

CAT40 End Mill Holder X-Long (ANSI/ASME B5.50-1994)

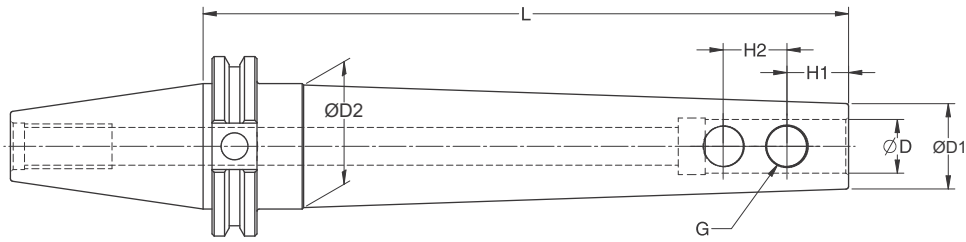

FEATURES

- Balanced to G2.5 @ 25,000 RPM
- T.I.R. < 0.0004"
- Taper shank ground to AT3 accuracy (or better)
- Bore tolerance: H6

Catalog Number	Description	ØD (inch)	ØD2 (inch)	ØD1 (inch)	L	H1	H2	G	Coolant Style
84240720XL	CAT40-EMHXL 0.125-4	0.125	0.68	0.50	4.00	0.22	-	#10-32 x 3/32	AD THRU
84240730XL	CAT40-EMHXL 0.125-6	0.125	0.82	0.50	6.00	0.22	-	#10-32 X 3/32	AD THRU
84240746XL	CAT40-EMHXL 0.125-9	0.125	1.03	0.50	9.00	0.22	-	#10-32 X 3/32	AD THRU
84240920XL	CAT40-EMHXL 0.187-4	0.187	0.74	0.56	4.00	0.56	-	#10-32 X 1/8	AD THRU
84240930XL	CAT40-EMHXL 0.187-6	0.187	0.88	0.56	6.00	0.56	-	#10-32 X 1/8	AD THRU
84240946XL	CAT40-EMHXL 0.187-9	0.187	1.09	0.56	9.00	0.56	-	#10-32 X 1/8	AD THRU
84241120XL	CAT40-EMHXL 0.250-4	0.250	0.77	0.59	4.00	0.56	-	#10-32 X 1/8	AD THRU
84241130XL	CAT40-EMHXL 0.250-6	0.250	0.91	0.59	6.00	0.56	-	#10-32 X 1/8	AD THRU
84241146XL	CAT40-EMHXL 0.250-9	0.250	1.12	0.59	9.00	0.56	-	#10-32 X 1/8	AD THRU
84241320XL	CAT40-EMHXL 0.312-4	0.312	0.80	0.62	4.00	0.75	-	1/4-28 X 1/8	AD THRU
84241330XL	CAT40-EMHXL 0.312-6	0.312	0.94	0.62	6.00	0.75	-	1/4-28 X 1/8	AD THRU
84241346XL	CAT40-EMHXL 0.312-9	0.312	1.15	0.62	9.00	0.75	-	1/4-28 X 1/8	AD THRU
84242620XL	CAT40-EMHXL 0.375-4	0.375	0.98	0.81	4.00	0.75	-	5/16-24 X 5/32	AD THRU
84242630XL	CAT40-EMHXL 0.375-6	0.375	1.12	0.81	6.00	0.75	-	5/16-24 X 5/32	AD THRU
84242646XL	CAT40-EMHXL 0.375-9	0.375	1.33	0.81	9.00	0.75	-	5/16-24 X 5/32	AD THRU
84242720XL	CAT40-EMHXL 0.437-4	0.437	1.04	0.87	4.00	0.88	-	3/8-24 X 3/16	AD THRU
84242730XL	CAT40-EMHXL 0.437-6	0.437	1.18	0.87	6.00	0.88	-	3/8-24 X 3/16	AD THRU
84242746XL	CAT40-EMHXL 0.437-9	0.437	1.39	0.87	9.00	0.88	-	3/8-24 X 3/16	AD THRU
84241520XL	CAT40-EMHXL 0.500-4	0.500	1.11	0.94	4.00	0.88	-	7/16-20 X 7/32	AD THRU
84241530XL	CAT40-EMHXL 0.500-6	0.500	1.25	0.94	6.00	0.88	-	7/16-20 X 7/32	AD THRU
84241546XL	CAT40-EMHXL 0.500-9	0.500	1.46	0.94	9.00	0.88	-	7/16-20 X 7/32	AD THRU
84243320XL	CAT40-EMHXL 0.562-4	0.562	1.11	0.94	4.00	0.94	-	1/2-20 X 1/4	AD THRU
84243330XL	CAT40-EMHXL 0.562-6	0.562	1.25	0.94	6.00	0.94	-	1/2-20 X 1/4	AD THRU
84243346XL	CAT40-EMHXL 0.562-9	0.562	1.46	0.94	9.00	0.94	-	1/2-20 X 1/4	AD THRU
84241720XL	CAT40-EMHXL 0.625-4	0.625	1.23	1.06	4.00	0.94	-	1/2-20 X 1/4	AD THRU
84241730XL	CAT40-EMHXL 0.625-6	0.625	1.37	1.06	6.00	0.94	-	1/2-20 X 1/4	AD THRU
84241746XL	CAT40-EMHXL 0.625-9	0.625	1.58	1.06	9.00	0.94	-	1/2-20 X 1/4	AD THRU
84242820XL	CAT40-EMHXL 0.750-4	0.750	1.36	1.19	4.00	1.00	-	1/2-20 X 1/4	AD THRU
84242830XL	CAT40-EMHXL 0.750-6	0.750	1.50	1.19	6.00	1.00	-	1/2-20 X 1/4	AD THRU
84242846XL	CAT40-EMHXL 0.750-9	0.750	1.71	1.19	9.00	1.00	-	1/2-20 X 1/4	AD THRU
84241920XL	CAT40-EMHXL 0.875-4	0.875	1.48	1.31	4.00	1.00	0.81	5/8-18 X 5/16	AD THRU
84241930XL	CAT40-EMHXL 0.875-6	0.875	1.62	1.31	6.00	1.00	0.81	5/8-18 X 5/16	AD THRU
84241946XL	CAT40-EMHXL 0.875-9	0.875	1.75	1.31	9.00	1.00	0.81	5/8-18 X 5/16	AD THRU
84242120XL	CAT40-EMHXL 1.000-4	1.000	1.75	1.62	4.00	1.12	1.00	5/8-18 X 5/16	AD THRU
84242130XL	CAT40-EMHXL 1.000-6	1.000	1.75	1.62	6.00	1.12	1.00	5/8-18 X 5/16	AD THRU
84242146XL	CAT40-EMHXL 1.000-9	1.000	1.75	1.62	9.00	1.12	1.00	5/8-18 X 5/16	AD THRU
84242220XL	CAT40-EMHXL 1.250-4	1.250	2.04	1.75	4.00	1.12	1.00	5/8-18 X 5/16	AD THRU
84242230XL	CAT40-EMHXL 1.250-6	1.250	2.18	1.75	6.00	1.12	1.00	5/8-18 X 5/16	AD THRU
84242246XL	CAT40-EMHXL 1.250-9	1.250	2.39	1.75	9.00	1.12	1.00	5/8-18 X 5/16	AD THRU

Retention knobs on page 198-199

CAT Holders

CAT40 End Mill Holder IK (ANSI/ASME B5.50-1994)

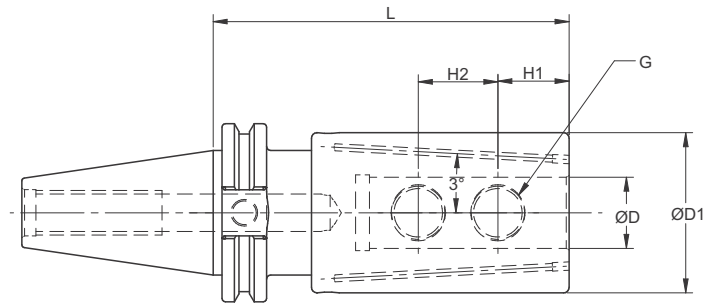

FEATURES

- Balanced to G2.5 @ 25,000 RPM
- T.I.R. < 0.0004"
- Taper shank ground to AT3 accuracy (or better)
- Bore tolerance: H6

Catalog Number	Description	ØD (inch)	L (inch)	ØD1 (inch)	H1	H2	G	Coolant Style
84240713-2CP	CAT40-EMH IK 0.125-2.50	0.125	2.50	0.73	0.56	-	10-32	Face THRU
84240913-2CP	CAT40-EMH IK 0.187-2.50	0.187	2.50	0.73	0.56	-	10-32	Face THRU
84241113-2CP	CAT40-EMH IK 0.250-2.50	0.250	2.50	0.88	0.56	-	1/4-28	Face THRU
84241120-2CP	CAT40-EMH IK 0.250-4.00	0.250	4.00	0.88	0.56	-	1/4-28	Face THRU
94241313-2CP	CAT40-EMH IK 0.312-2.50	0.312	2.50	1.00	0.75	-	1/4-28	Face THRU
84242615-2CP	CAT40-EMH IK 0.375-3.00	0.375	3.00	1.25	0.75	-	3/8-24	Face THRU
84241515-2CP	CAT40-EMH IK 0.500-3.00	0.500	3.00	1.38	0.88	-	7/16-20	Face THRU
84241523-2CP	CAT40-EMH IK 0.500-4.62	0.500	4.62	1.38	0.88	-	7/16-20	Face THRU
84241718-2CP	CAT40-EMH IK 0.625-3.54	0.625	3.54	1.62	0.94	-	9/16-18	Face THRU
84242818-2CP	CAT40-EMH IK 0.750-3.50	0.750	3.50	1.75	1.00	-	5/8-18	Face THRU
84242125-2CP	CAT40-EMH IK 1.000-5.00	1.000	5.00	2.25	1.00	1.12	3/4-16	Face THRU
84242325-2CP	CAT40-EMH IK 1.500-5.00	1.500	5.00	2.75	1.12	1.00	3/4-16	Face THRU

Retention knobs on page 198-199

CAT Holders

CAT40 Morse Taper Socket (ANSI-ASME B5.50-1994)

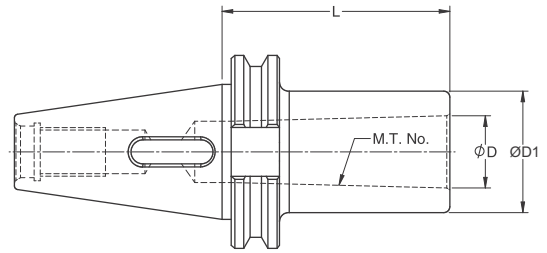

FEATURES

- Balanced to G2.5 @ 25,000 RPM
- Taper shank ground to AT3 accuracy (or better)

Catalog Number	Description	MT Socket	ØD (inch)	L (inch)	ØD1 (inch)	Coolant Style
88024109	CAT40-MTA 1-1.77	1	0.475	1.77	0.98	N/A
88024209	CAT40-MTA 2-1.77	2	0.700	1.77	1.25	N/A
88024315	CAT40-MTA 3-2.95	3	0.938	2.95	1.57	N/A
88024418	CAT40-MTA 4-3.54	4	1.231	3.54	1.97	N/A

CAT40 Shell Mill Holder (ANSI-ASME B5.50-1994)

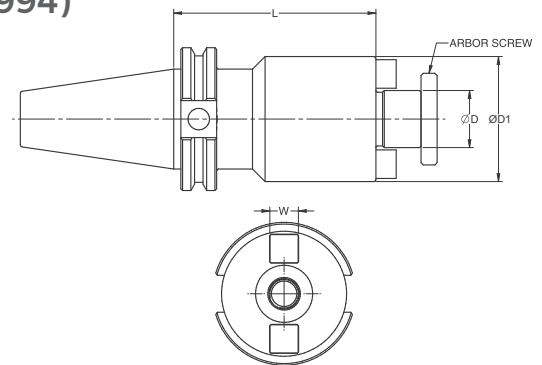

FEATURES

- Balanced to G2.5 @ 25,000 RPM
- T.I.R. < 0.0002"
- Taper shank ground to AT3 accuracy (or better)
- Coolant Through the Center of the body

Catalog Number	Description	ØD (inch)	L (inch)	ØD1 (inch)	W (inch)	Arbor Screw	Coolant Style
81245007	CAT40-SMH 0.500-1.38	0.500	1.38	1.75	0.250	1/4"-28	AD Thru
81247509	CAT40-SMH 0.750-1.77	0.750	1.77	1.75	0.312	3/8"-24	AD Thru
81247518	CAT40-SMH 0.750-3.54	0.750	3.54	1.75	0.312	3/8"-24	AD Thru
81241012	CAT40-SMH 1.000-2.36	1.000	2.36	2.19	0.375	1/2"-20	AD Thru
81241018	CAT40-SMH 1.000-3.54	1.000	3.54	2.19	0.375	1/2"-20	AD Thru
81241030	CAT40-SMH 1.000-6.00	1.000	6.00	2.19	0.375	1/2"-20	AD Thru
81241212	CAT40-SMH 1.250-2.36	1.250	2.36	2.75	0.500	5/8"-18	AD Thru
81241222	CAT40-SMH 1.250-4.25	1.250	4.25	2.75	0.500	5/8"-18	AD Thru
80241512	CAT40-SMH 1.500-2.36	1.500	2.36	3.38	0.625	3/4"-16	AD Thru
80241520	CAT40-SMH 1.500-4.00	1.500	4.00	3.38	0.625	3/4"-16	AD Thru
81241607	CAT40-SMH 16-35	16mm	35mm	35mm	8mm	M8 x L25 *	AD Thru
84242210	CAT40-SMH 22-50	22mm	50mm	45mm	10mm	M10 x L25 *	AD Thru
81242220	CAT40-SMH 22-100	22mm	100mm	45mm	10mm	M10 x L25 *	AD Thru
81242710	CAT40-SMH 27-50	27mm	50mm	70mm	12mm	M12 x L30 *	AD Thru
81242720	CAT40-SMH 27-100	27mm	100mm	70mm	12mm	M12 x L30 *	AD Thru

NOTE: ALL Shell Mill Holders are supplied with coolant through the center up to the arbor screw hole.

NOTE: * Represents holders provide with metric allen cap bolt.

Retention knobs on page 198-199

Non-Coolant and Coolant Arbor Screws on page 202

CAT Holders

CAT40 Shell Mill Holder X-Long (ANSI-ASME B5.50-1994)

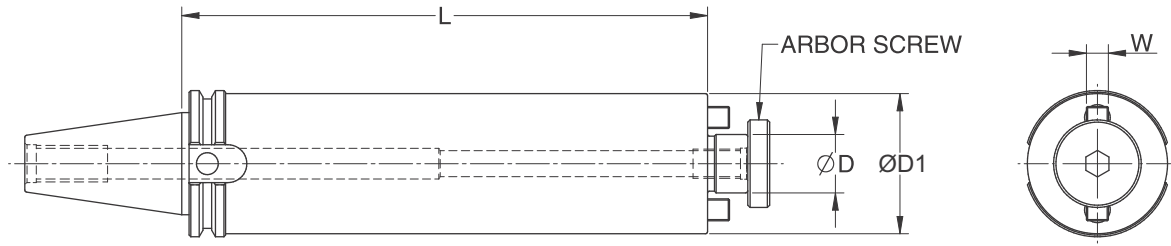

FEATURES

- Balanced to G2.5 @ 25,000 RPM
- T.I.R. < 0.0004"
- Taper shank ground to AT3 accuracy (or better)
- Coolant Through the Center of the body

Catalog Number	Description	ØD (inch)	ØD1 (inch)	L (inch)	W (inch)	Arbor Screw	Coolant Style
81245025XL	CAT40-SMHXL 0.500-5	0.500	1.25	5.00	0.250	1/4"-28	AD THRU
81245041XL	CAT40-SMHXL 0.500-8	0.500	1.25	8.00	0.250	1/4"-28	AD THRU
812475S20XL	CAT-40-SMHXL 0.750-4S	0.750	1.40	4.00	0.312	3/8"-24	AD THRU
812475S30XL	CAT40-SMHXL 0.750-6S	0.750	1.40	6.00	0.312	3/8"-24	AD THRU
812475S46XL	CAT40-SMHXL 0.750-9S	0.750	1.40	9.00	0.312	3/8"-24	AD THRU
812475W20XL	CAT40-SMHXL 0.750-4W	0.750	1.90	4.00	0.312	3/8"-24	AD THRU
812475W30XL	CAT40-SMHXL 0.750-6W	0.750	1.90	6.00	0.312	3/8"-24	AD THRU
812475W46XL	CAT40-SMHXL 0.750-9W	0.750	1.90	9.00	0.312	3/8"-24	AD THRU
81241020XL	CAT40-SMHXL1.000-4	1.000	2.40	4.00	0.375	1/2"-20	AD THRU
81241030XL	CAT40-SMHXL1.000-6	1.000	2.40	6.00	0.375	1/2"-20	AD THRU
81241046XL	CAT40-SMHXL1.000-9	1.000	2.40	9.00	0.375	1/2"-20	AD THRU
81241220XL	CAT40-SMHXL1.250-4	1.250	2.90	4.00	0.500	5/8"-18	AD THRU
81241230XL	CAT40-SMHXL1.250-6	1.250	2.90	6.00	0.500	5/8"-18	AD THRU
81241246XL	CAT40-SMHXL1.250-9	1.250	2.90	9.00	0.500	5/8"-18	AD THRU
80241520XL	CAT40-SMHXL1.500-4	1.500	3.88	4.00	0.625	3/4"-16	AD THRU

NOTE:

ALL Shell Mill Holders are supplied with coolant through the center up to the arbor screw hole.

Retention knobs [on page 198-199](#)

Non-Coolant and Coolant Arbor Screws [on page 202](#)

CAT40 Jacob Taper Holder (ANSI-ASME B5.5-1994)

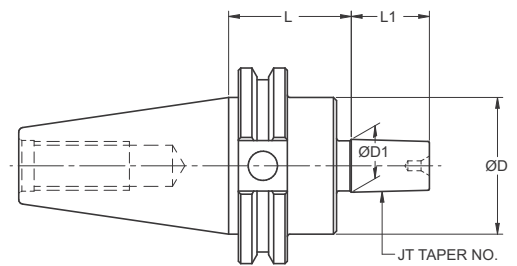
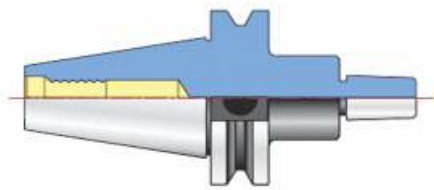

FEATURES

- Balanced to G2.5 @ 25,000 RPM
- Taper shank ground to AT3 accuracy (or better)

Catalog Number	Description	JT Taper No.	L	L1	ØD	ØD1
88424108	CAT40-JTA 1-1.57	1	1.57	0.656	1.75	0.384
88424208	CAT40-JTA 2-1.57	2	1.57	0.875	1.75	0.559
88424308	CAT40-JTA 3-1.57	3	1.57	1.219	1.75	0.811
88424408	CAT40-JTA 4-1.57	4	1.57	1.656	1.75	1.124
88424608	CAT40-JTA 6-1.57	6	1.57	1.000	1.75	0.676
884243308	CAT40-JTA 33-1.57	33	1.57	1.000	1.75	0.624

CAT Holders

CAT40 ER Collet Holder (ANSI/ASME B5.50-1994)

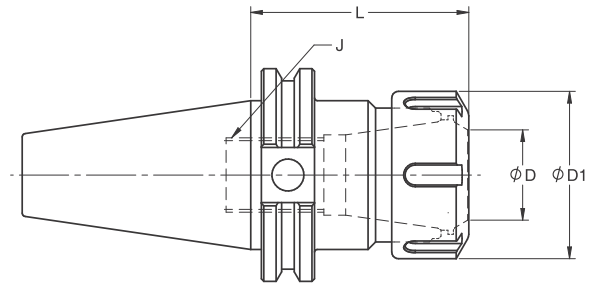

FEATURES

- Balanced to G2.5 @ 25,000 RPM
- T.I.R. < 0.0002"
- AD coolant thru the spindle
- Taper shank ground to AT3 accuracy (or better)
- Balanced ER Collet Nuts

Catalog Number	Description	Collet Size	ϕD Range	$\phi D1$ (inch)	L (inch)	J (inch)	Coolant Style
872240M14	CAT40-CHE 11M-2.75	ER11	.118 - .275	0.630	2.75	5/16-24LH	AD Thru
872240M20	CAT40-CHE 11M-4.00	ER11	.118 - .275	0.630	4.00	5/16-24LH	AD Thru
872240M30	CAT40-CHE 11M-6.00	ER11	.118 - .275	0.630	6.00	5/16-24LH	AD Thru
87224014	CAT40-CHE 11-2.75	ER11	.118 - .275	0.748	2.75	5/16-24LH	AD Thru
87224020	CAT40-CHE 11-4.00	ER11	.118 - .275	0.748	4.00	5/16-24LH	AD Thru
87224025	CAT40-CHE 11-5.00	ER11	.118 - .275	0.748	5.00	5/16-24LH	AD Thru
87224114	CAT40-CHE 16-2.75	ER16	.118 - .393	1.102	2.76	7/16-16LH	AD Thru
87224120	CAT40-CHE 16-4.00	ER16	.118 - .393	1.102	4.00	7/16-16LH	AD Thru
87224125	CAT40-CHE 16-5.00	ER16	.118 - .393	1.102	5.00	7/16-16LH	AD Thru
87224130	CAT40-CHE 16-6.00	ER16	.118 - .393	1.102	6.00	7/16-16LH	AD Thru
87224141	CAT40-CHE 16-8.00	ER16	.118 - .393	1.102	8.00	7/16-16 LH	AD Thru
872241M20	CAT40-CHE 16M-4.00	ER16	.118 - .393	0.866	4.00	7/16-16 LH	AD Thru
872241M30	CAT40-CHE 16M-6.00	ER16	.118 - .393	0.866	6.00	7/16-16 LH	AD Thru
872241M41	CAT40-CHE 16M-8.00	ER16	.118 - .393	0.866	8.00	7/16-16 LH	AD Thru
87224214	CAT40-CHE 20-2.75	ER20	.118 - .511	1.338	2.75	9/16-16LH	AD Thru
87224220	CAT40-CHE 20-4.00	ER20	.118 - .511	1.338	4.00	9/16-16LH	AD Thru
87224230	CAT40-CHE 20-6.00	ER20	.118 - .511	1.338	5.51	9/16-16LH	AD Thru
87224241	CAT40-CHE 20-8.00	ER20	.118 - .511	1.338	8.00	9/16-16LH	AD Thru
87224314	CAT40-CHE 25-2.75	ER25	.118 - .629	1.653	2.75	11/16-16LH	AD Thru
87224320	CAT40-CHE 25-4.00	ER25	.118 - .629	1.653	4.00	11/16-16LH	AD Thru
87224330	CAT40-CHE 25-6.00	ER25	.118 - .629	1.653	6.00	11/16-16LH	AD Thru
87224341	CAT40-CHE 25-8.00	ER25	.118 - .629	1.653	8.00	11/16-16LH	AD Thru
87224414	CAT40-CHE 32-2.75	ER32	.118 - .787	1.968	2.75	7/8-16LH	AD Thru
87224420	CAT40-CHE 32-4.00	ER32	.118 - .787	1.968	4.00	7/8-16LH	AD Thru
87224430	CAT40-CHE 32-6.00	ER32	.118 - .787	1.968	6.00	7/8-16LH	AD Thru
87224441	CAT40-CHE 32-8.00	ER32	.118 - .787	1.968	8.00	7/8-16LH	AD Thru
87224516	CAT40-CHE 40-3.00	ER40	.157 - 1.023	2.480	3.00	1.1/8-16LH	AD Thru
87224520	CAT40-CHE 40-4.00	ER40	.157 - 1.023	2.480	4.00	1.1/8-16LH	AD Thru
87224530	CAT40-CHE 40-6.00	ER40	.157 - 1.023	2.480	6.00	1.1/8-16LH	AD Thru
87224541	CAT40-CHE 40-8.00	ER40	.157 - 1.023	2.480	8.00	1.1/8"-16LH	AD Thru

ER Collets on page 182-186
 ER Nut Wrenches on page 203
 Retention knobs on page 198-199

CAT Holders

CAT40 AccuMill™ Multi-Milling Chuck (ANSI-ASME B5.50-1994)

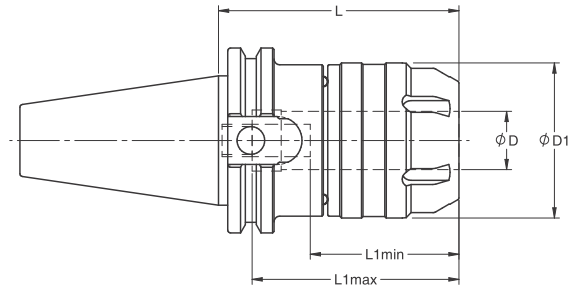

FEATURES

- Balanced to G2.5 @ 25,000 RPM
- T.I.R. < 0.0002"
- Taper shank ground to AT3 accuracy (or better)
- Bore tolerance: H6

Catalog Number	Description	Collet Size	Collect Capacity Range	ϕD	$\phi D1$	L	L1 Min/Max	Coolant Style
CAT40 Inch								
97242818	CAT40-MMC 0.750-3.50	MC75	.125 - .625	0.75	2.09	3.50	2.50/2.75	AD Thru
97242825	CAT40-MMC 0.750-5.00	MC75	.125 - .625	0.75	2.09	5.00	2.50/2.75	AD Thru
97242118	CAT40-MMC 1.000-3.50	MC1.00	.125 - .750	1.00	2.09	3.50	2.50/2.76	AD Thru
97242218	CAT40-MMC 1.250-3.50	MC1.25	.125 - 1.00	1.25	2.64	3.50	3.09/3.34	AD Thru
97242225	CAT40-MMC 1.250-5.00	MC1.25	.125 - 1.00	1.25	2.64	5.00	3.09/3.34	AD Thru
CAT40 Metric								
97242018	CAT40-MMC 20-90	MC20	3 - 16	20	53	90	63/70	AD Thru
97242024	CAT40-MMC 20-120	MC20	3 - 16	20	53	120	63/70	AD Thru
97243218	CAT40-MMC 32-90	MC32	3 - 25	32	67	90	78/85	AD Thru
97243224	CAT40-MMC 32-120	MC32	3 - 25	32	67	120	78/85	AD Thru

AccuMill™ Collets on page 191-192
 AccuMill™ Collet Nut wrenches on page 201
 Retention knobs on page 198-199

CAT40 AccuClamp™ Hydraulic Chucks (ANSI/ASME B5.50-1994)

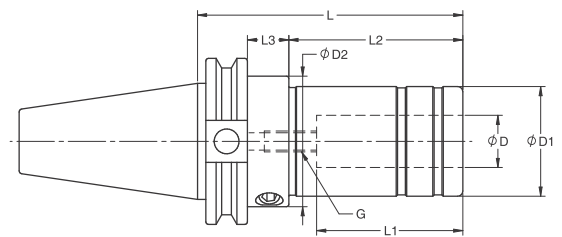

FEATURES

- Balanced to G2.5 @ 25,000 RPM
- T.I.R. < 0.0002"
- Taper shank ground to AT3 accuracy (or better)
- Bore tolerance: H6

Catalog Number	Description	ϕD (inch)	$\phi D1$ (inch)	$\phi D2$ (inch)	L (inch)	L1 (inch)	L2 (inch)	L3 (inch)	G (inch)	Coolant Style
CAT40 Inch										
68242820	CAT40-HCS 0.750-4.00	0.750	1.65	2.05	4.00	2.05	2.28	0.96	M8x1	AD Thru
68242223	CAT40-HCS 1.250-4.52	1.250	2.36	2.36	4.52	2.44	3.78	-	M8x1	AD Thru
CAT40 Metric										
68242020	CAT40-HCS 20-100	20.00	42	52	100	52	56.4	24.5	M8x1	AD Thru
68243223	CAT40-HCS 32-115	32.00	60	60	115	60	60	-	M8x1	AD Thru

AccuClamp™ Torque wrenches on page 204
 AccuClamp™ Reduction Sleeves on page 191-192
 Retention knobs on page 198-199

CAT Holders

CAT40 AccuClamp™ Hydraulic Chucks Slim Design (ANSI/ASME B5.50-1994)

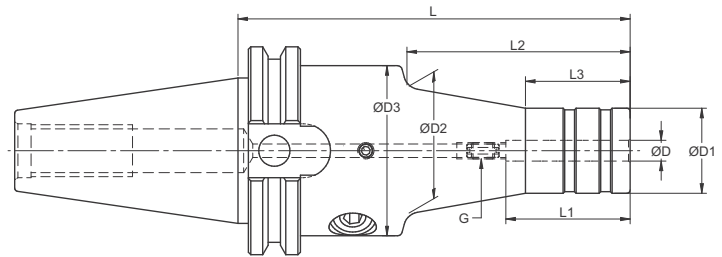

FEATURES

- Balanced to G2.5 @ 25,000 RPM
- T.I.R. < 0.0002"
- Taper shank ground to AT3 accuracy (or better)
- Bore tolerance: H6

Catalog Number	Description	ØD (inch)	ØD1 (inch)	ØD2 (inch)	ØD3 (inch)	L (inch)	L1 (inch)	L2 (inch)	L3 (inch)	G	Coolant Style
68241124SL	CAT40-HCSL 0.250-4.72	0.250	1.03	1.53	2.05	4.72	1.50	2.68	1.26	M5x0.8	AD Thru
68241324SL	CAT40-HCSL 0.312-4.72	0.312	1.10	1.61	2.05	4.72	1.65	2.68	1.26	M5x0.8	AD Thru
68242624SL	CAT40-HCSL 0.375-4.72	0.375	1.18	1.69	2.05	4.72	1.77	2.68	1.26	M6x1	AD Thru
68241524SL	CAT40 HCSL 0.500-4.72	0.500	1.26	1.77	2.05	4.72	1.81	2.68	1.26	M8x1	AD Thru

AccuClamp™ Torque wrenches [on page 204](#)

AccuClamp™ Reduction Sleeves [on page 191-192](#)

Retention knobs [on page 198-199](#)

CAT40 AccuClamp™ Heavy Duty Hydraulic Chucks (ANSI-ASME B5.50-1994)

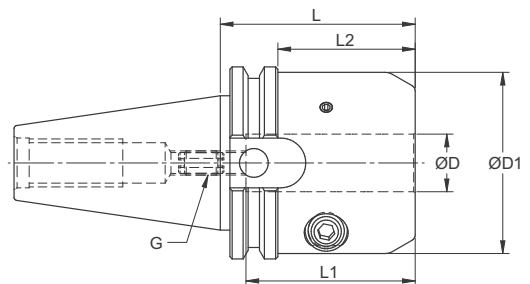

FEATURES

- Balanced to G2.5 @ 25,000 RPM
- T.I.R. < 0.0002"
- Taper shank ground to AT3 accuracy (or better)
- Bore tolerance: H6

Catalog Number	Description	ØD	ØD1	L	L1	L2	G	Coolant Style
67242813	CAT40-HC 0.750-2.50	0.75	2.36	2.50	2.05	1.75	M8x1	AD Thru
67242217	CAT40-HC 1.250-3.25	1.25	2.84	3.25	2.44	2.50	M8x1	AD Thru

AccuClamp™ Torque wrenches [on page 204](#)

AccuClamp™ Reduction Sleeves [on page 191-192](#)

Retention knobs [on page 198-199](#)

CAT Holders

CAT50 End Mill Holder (ANSI/ASME B5.50-1994)

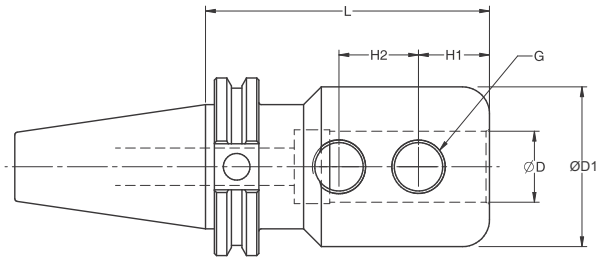

FEATURES

- Balanced to G2.5 @ 25,000 RPM
- T.I.R. < 0.0004"
- Taper shank ground to AT3 accuracy (or better)
- Bore tolerance: H6

Catalog Number	Description	ØD (inch)	L (inch)	ØD1 (inch)	H1	H2	G	Coolant Style
84260713	CAT50-EMH 0.125-2.50	0.125	2.50	0.50	0.22	-	#10-32	AD Thru
84260913	CAT50-EMH 0.187-2.50	0.187	2.50	0.69	0.56	-	#10-32	AD Thru
84261113	CAT50-EMH 0.250-2.50	0.250	2.50	0.69	0.56	-	1/4"-28	AD Thru
84261120	CAT50-EMH 0.250-4.00	0.250	4.00	0.69	0.56	-	1/4"-28	AD Thru
84261313	CAT50-EMH 0.312-2.50	0.312	2.50	1.00	0.75	-	1/4"-28	AD Thru
84261320	CAT50-EMH 0.312-4.00	0.312	4.00	1.00	0.75	-	1/4"-28	AD Thru
84262613	CAT50-EMH 0.375-2.50	0.375	2.50	1.00	0.75	-	3/8"-24	AD Thru
84262620	CAT50-EMH 0.375-4.00	0.375	4.00	1.00	0.75	-	3/8"-24	AD Thru
84262630	CAT50-EMH 0.375-6.00	0.375	6.00	1.00	0.75	-	3/8"-24	AD Thru
84262720	CAT50-EMH 0.4375-4.00	0.4375	4.00	1.38	0.88	-	7/16"-20	AD Thru
84261513	CAT50-EMH 0.500-2.62	0.500	2.62	1.38	0.88	-	7/16"-20	AD Thru
84261520	CAT50-EMH 0.500-4.00	0.500	4.00	1.38	0.88	-	7/16"-20	AD Thru
84261530	CAT50-EMH 0.500-6.00	0.500	6.00	1.38	0.88	-	7/16"-20	AD Thru
84261541	CAT50-EMH 0.500-8.00	0.500	8.00	1.38	0.88	-	7/16"-20	AD Thru
84263320	CAT50-EMH 5.625-4.00	0.5625	4.00	1.62	0.94	-	9/16"-18	AD Thru
84261720	CAT50-EMH 0.625-4.00	0.625	4.00	1.62	0.94	-	9/16"-18	AD Thru
84261730	CAT50-EMH 0.625-6.00	0.625	6.00	1.62	0.94	-	9/16"-18	AD Thru
84261741	CAT50-EMH 0.625-8.00	0.625	8.00	1.62	0.94	-	9/16"-18	AD Thru
84262820	CAT50-EMH 0.750-4.00	0.750	4.00	1.75	1.00	-	5/8"-18	AD Thru
84262830	CAT50-EMH 0.750-6.00	0.750	6.00	1.75	1.00	-	5/8"-18	AD Thru
84262841	CAT50-EMH 0.750-8.00	0.750	8.00	1.75	1.00	-	5/8"-18	AD Thru
84261920	CAT50-EMH 0.875-4.00	0.875	4.00	2.00	1.00	0.81	5/8"-18	AD Thru
84261930	CAT50-EMH 0.875-6.00	0.875	6.00	2.00	1.00	0.81	5/8"-18	AD Thru
84262113	CAT50-EMH 1.000-2.62	1.000	2.62	2.75	1.12	-	3/4"-16	AD Thru
84262120	CAT50-EMH 1.000-4.00	1.000	4.00	2.25	1.12	1.00	3/4"-16	AD Thru
84262130	CAT50-EMH 1.000-6.00	1.000	6.00	2.25	1.12	1.00	3/4"-16	AD Thru
84262141	CAT50-EMH 1.000-8.00	1.000	8.00	2.25	1.12	1.00	3/4"-16	AD Thru
84262215	CAT50-EMH 1.250-3.00	1.250	3.00	2.50	1.12	1.00	3/4"-16	AD Thru
84262220	CAT50-EMH 1.250-4.00	1.250	4.00	2.50	1.12	1.00	3/4"-16	AD Thru
84262230	CAT50-EMH 1.250-6.00	1.250	6.00	2.50	1.12	1.00	3/4"-16	AD Thru
84262241	CAT50-EMH 1.250-8.00	1.250	8.00	2.50	1.12	1.00	3/4"-16	AD Thru
84262246	CAT50-EMH 1.250-9.00	1.250	9.00	2.50	1.12	1.00	3/4"-16	AD Thru
84262320	CAT50-EMH 1.500-4.00	1.500	4.00	2.75	1.12	1.00	3/4"-16	AD Thru
84262330	CAT50-EMH 1.500-6.00	1.500	6.00	2.75	1.12	1.00	3/4"-16	AD Thru
84262341	CAT50-EMH 1.500-8.00	1.500	8.00	2.75	1.12	1.00	3/4"-16	AD Thru
84262929	CAT50-EMH 2.000-5.62	2.000	5.62	3.75	1.38	1.50	1"-14	AD Thru
84262939	CAT50-EMH 2.000-7.75	2.000	7.75	3.75	1.38	1.50	1"-14	AD Thru
84263130	CAT50-EMH 2.500-6.00	2.500	6.00	4.25	1.56	1.69	1"-14	AD Thru
84260613	CAT50-EMH 6-65	6mm	65mm	25mm	18mm	-	M6x1	AD Thru
84260813	CAT50-EMH 8-65	8mm	65mm	28mm	18mm	-	M8x1.25	AD Thru
84261020	CAT50-EMH 10-100	10mm	100mm	35mm	20mm	-	M10x1.5	AD Thru
84261220	CAT50-EMH 12-100	12mm	100mm	42mm	22.5mm	-	M12x1.75	AD Thru
84261620	CAT50-EMH 16-100	16mm	100mm	48mm	24mm	-	M14x2	AD Thru
84262020	CAT50-EMH 20-100	20mm	100mm	52mm	25mm	-	M16x2	AD Thru
84262520	CAT50-EMH 25-100	25mm	100mm	65mm	24mm	25mm	M18x2	AD Thru
84262530	CAT50-EMH 25-6.00	25mm	152.4mm	65mm	24mm	25mm	M18x2	AD Thru
84262532	CAT50-EMH 25-160	25mm	160mm	65mm	24mm	25mm	M18x2	AD Thru

CAT Holders

CAT50 End Mill Holder X-Long (ANSI/ASME B5.50-1994)

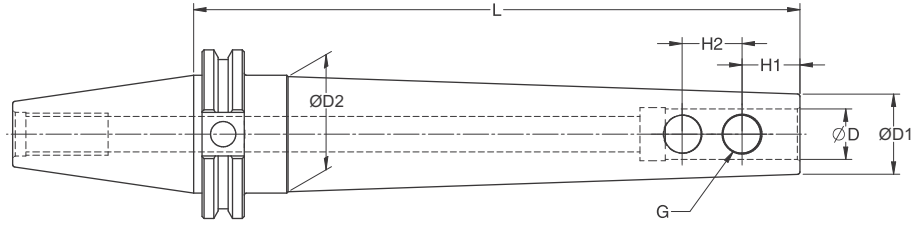

FEATURES

- Balanced to G2.5 @ 25,000 RPM
- Taper shank ground to AT3 accuracy (or better)
- T.I.R. < 0.0004"

Catalog Number	Description	ØD (inch)	ØD2 (inch)	ØD1 (inch)	L	H1	H2	G	Coolant Style
84260746XL	CAT50-EMHXL 0.125-9	0.125	1.04	0.50	9.0	0.22	-	#10-32 X 3/32	AD THRU
84260930XL	CAT50-EMHXL 0.187-6	0.187	0.88	0.56	6.0	0.56	-	#10-32 X 1/8	AD THRU
84260946XL	CAT50-EMHXL 0.187-9	0.187	1.11	0.56	9.0	0.56	-	#10-32 X 1/8	AD THRU
84261130XL	CAT50-EMHXL 0.250-6	0.250	0.91	0.59	6.0	0.56	-	#10-32 X 1/8	AD THRU
84261146XL	CAT50-EMHXL 0.250-9	0.250	1.12	0.59	9.0	0.56	-	#10-32 X 1/8	AD THRU
84261161XL	CAT50-EMHXL 0.250-12	0.250	1.33	0.59	12.0	0.56	-	#10-32 X 1/8	AD THRU
84261176XL	CAT50-EMHXL 0.250-15	0.250	1.53	0.59	15.0	0.56	-	#10-32 X 1/8	AD THRU
84261330XL	CAT50-EMHXL 0.312-6	0.312	0.94	0.62	6.0	0.75	-	1/4-28 X 1/8	AD THRU
84261346XL	CAT50-EMHXL 0.312-9	0.312	1.15	0.62	9.0	0.75	-	1/4-28 X 1/8	AD THRU
84261361XL	CAT50-EMHXL 0.312-12	0.312	1.36	0.62	12.0	0.75	-	1/4-28 X 1/8	AD THRU
84261376XL	CAT50-EMHXL 0.312-15	0.312	1.57	0.62	15.0	0.75	-	1/4-28 X 1/8	AD THRU
84262630XL	CAT50-EMHXL 0.375-6	0.375	1.12	0.81	6.0	0.75	-	5/16-24 X 5/32	AD THRU
84262646XL	CAT50-EMHXL 0.375-9	0.375	1.33	0.81	9.0	0.75	-	5/16-24 X 5/32	AD THRU
84262661XL	CAT50-EMHXL 0.375-12	0.375	1.54	0.81	12.0	0.75	-	5/16-24 X 5/32	AD THRU
84262676XL	CAT50-EMHXL 0.375-15	0.375	1.75	0.81	15.0	0.75	-	5/16-24 X 5/32	AD THRU
84262730XL	CAT50-EMHXL 0.437-6	0.437	1.19	0.87	6.0	0.88	-	3/8-24 X 3/16	AD THRU
84262746XL	CAT50-EMHXL 0.437-9	0.437	1.4	0.87	9.0	0.88	-	3/8-24 X 3/16	AD THRU
84262761XL	CAT50-EMHXL 0.437-12	0.437	1.61	0.87	12.0	0.88	-	3/8-24 X 3/16	AD THRU
84262776XL	CAT50-EMHXL 0.437-15	0.437	1.77	0.87	15.0	0.88	-	3/8-24 X 3/16	AD THRU
84261530XL	CAT50-EMHXL 0.500-6	0.500	1.25	0.94	6.0	0.88	-	7/16-20 X 7/32	AD THRU
84261546XL	CAT50-EMHXL 0.500-9	0.500	1.46	0.94	9.0	0.88	-	7/16-20 X 7/32	AD THRU
84261561XL	CAT50-EMHXL 0.500-12	0.500	1.67	0.94	12.0	0.88	-	7/16-20 X 7/32	AD THRU
84261576XL	CAT50-EMHXL 0.500-15	0.500	1.88	0.94	15.0	0.88	-	7/16-20 X 7/32	AD THRU
84261730XL	CAT50-EMHXL 0.625-6	0.625	1.37	1.06	6.0	0.94	-	1/2-20 X 1/4	AD THRU
84261746XL	CAT50-EMHXL 0.625-9	0.625	1.58	1.06	9.0	0.94	-	1/2-20 X 1/4	AD THRU
84261761XL	CAT50-EMHXL 0.625-12	0.625	1.79	1.06	12.0	0.94	-	1/2-20 X 1/4	AD THRU
84261776XL	CAT50-EMHXL 0.625-15	0.625	2.00	1.06	15.0	0.94	-	1/2-20 X 1/4	AD THRU
84262830XL	CAT50-EMHXL 0.750-6	0.750	1.5	1.19	6.0	1.00	-	1/2-20 X 1/4	AD THRU
84262846XL	CAT50-EMHXL 0.750-9	0.750	1.71	1.19	9.0	1.00	-	1/2-20 X 1/4	AD THRU
84262861XL	CAT50-EMHXL 0.750-12	0.750	1.92	1.19	12.0	1.00	-	1/2-20 X 1/4	AD THRU
84262876XL	CAT50-EMHXL 0.750-15	0.750	2.13	1.19	15.0	1.00	-	1/2-20 X 1/4	AD THRU
84261930XL	CAT50-EMHXL 0.875-6	0.875	1.62	1.43	6.0	1.00	0.81	5/8-18 X 5/16	AD THRU
84261946XL	CAT50-EMHXL 0.875-9	0.875	1.83	1.43	9.0	1.00	0.81	5/8-18 X 5/16	AD THRU
84261961XL	CAT50-EMHXL 0.875-12	0.875	2.04	1.43	12.0	1.00	0.81	5/8-18 X 5/16	AD THRU
84261976XL	CAT50-EMHXL 0.875-15	0.875	2.25	1.43	15.0	1.00	0.81	5/8-18 X 5/16	AD THRU
84262130XL	CAT50-EMHXL 1.000-6	1.000	1.93	1.62	6.0	1.12	1.00	5/8-18 X 5/16	AD THRU
84262146XL	CAT50-EMHXL 1.000-9	1.000	2.13	1.62	9.0	1.12	1.00	5/8-18 X 5/16	AD THRU
84262161XL	CAT50-EMHXL 1.000-12	1.000	2.34	1.62	12.0	1.12	1.00	5/8-18 X 5/16	AD THRU
84262176XL	CAT50-EMHXL 1.000-15	1.000	2.55	1.62	15.0	1.12	1.00	5/8-18 X 5/16	AD THRU
84262230XL	CAT50-EMHXL 1.250-6	1.250	2.19	1.88	6.0	1.12	1.00	5/8-18 X 5/16	AD THRU
84262246XL	CAT50-EMHXL 1.250-9	1.250	2.39	1.88	9.0	1.12	1.00	5/8-18 X 5/16	AD THRU
84262261XL	CAT50-EMHXL 1.250-12	1.250	2.60	1.88	12.0	1.12	1.00	5/8-18 X 5/16	AD THRU
84262276XL	CAT50-EMHXL 1.250-15	1.250	2.75	1.88	15.0	1.12	1.00	5/8-18 X 5/16	AD THRU
84262330XL	CAT50-EMHXL 1.500-6	1.500	2.55	2.25	6.0	1.12	1.00	3/4-16 X 3/8	AD THRU
84262346XL	CAT50-EMHXL 1.500-9	1.500	2.75	2.25	9.0	1.12	1.00	3/4-16 X 3/8	AD THRU
84262361XL	CAT50-EMHXL 1.500-12	1.500	2.96	2.25	12.0	1.12	1.00	3/4-16 X 3/8	AD THRU
84262376XL	CAT50-EMHXL 1.500-15	1.500	3.17	2.25	15.0	1.12	1.00	3/4-16 X 3/8	AD THRU
84262930XL	CAT50-EMHXL 2.000-6	2.000	3.46	3.19	6.0	1.38	1.50	1-14 X 3/4	AD THRU
84262946XL	CAT50-EMHXL 2.000-9	2.000	3.66	3.19	9.0	1.38	1.50	1-14 X 3/4	AD THRU
84262961XL	CAT50-EMHXL 2.000-12	2.000	3.86	3.19	12.0	1.38	1.50	1-14 X 3/4	AD THRU
84262976XL	CAT50-EMHXL 2.000-15	2.000	3.86	3.19	15.0	1.38	1.50	1-14 X 3/4	AD THRU
84263136XL	CAT50-EMHXL 2.500-7	2.500	4.5	4.5	7.0	1.56	1.69	1-14 X 3/4	AD THRU

Retention knobs on page 198-199

CAT Holders

CAT50 End Mill Holder IK (ANSI/ASME B5.50-1994)

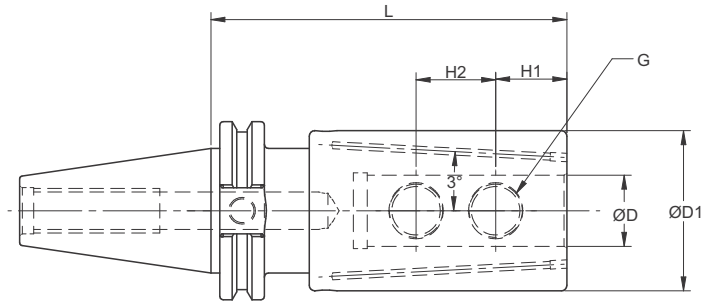

FEATURES

- Balanced to G2.5 @ 25,000 RPM
- Taper shank ground to AT3 accuracy (or better)
- T.I.R. < 0.0004"

Catalog Number	Description	ØD (inch)	ØD1 (inch)	L	H1	H2	G	Coolant Style
84260713-2CP	CAT50-EMH IK 2 0.125-2.50	0.125	0.73	2.50	0.56	-	10-32	Face THRU
84260913-2CP	CAT50-EMHIK 2 0.187-2.50	0.187	0.73	2.50	0.56	-	10-32	Face THRU
94261113-2CP	CAT50-EMH IK 2 0.250-2.50	0.250	0.88	2.50	0.56	-	1/4"-28	Face THRU
84261120-2CP	CAT50-EMH IK 2 0.250-4.00	0.250	0.88	4.00	0.56	-	1/4"-28	Face THRU
94261313-2CP	CAT50-EMH IK 2 0.312-2.50	0.312	1.00	2.50	0.75	-	1/4"-28	Face THRU
84262613-2CP	CAT50-EMH IK 2 0.375-2.50	0.375	1.25	2.50	0.75	-	3/8"-24	Face THRU
84262620-2CP	CAT50-EMH IK 2 0.375-2.50	0.375	1.25	4.00	0.75	-	3/8"-24	Face THRU
94261520-2CP	CAT50-EMH IK 2 0.500-4.00	0.500	1.38	4.00	0.88	-	7/16"-20	Face THRU
84261720-2CP	CAT50-EMH IK 2 0.625-4.00	1.625	1.62	4.00	0.94	-	9/16"-18	Face THRU
84262820-2CP	CAT50-EMH IK 2 0.750-4.00	0.750	1.75	4.00	1.00	-	5/8"-18	Face THRU
84262125-2CP	CAT50-EMH IK 2 1.000-5.00	1.000	2.25	5.00	1.00	1.12	3/4"-16	Face THRU
84262325-2CP	CAT50-EMH IK 2 1.500-5.00	1.500	2.75	5.00	1.12	1.00	3/4"-16	Face THRU

Retention knobs on page 198-199

CAT Holders

CAT50 Shell Mill Holder (ANSI-ASME B5.500-1994)

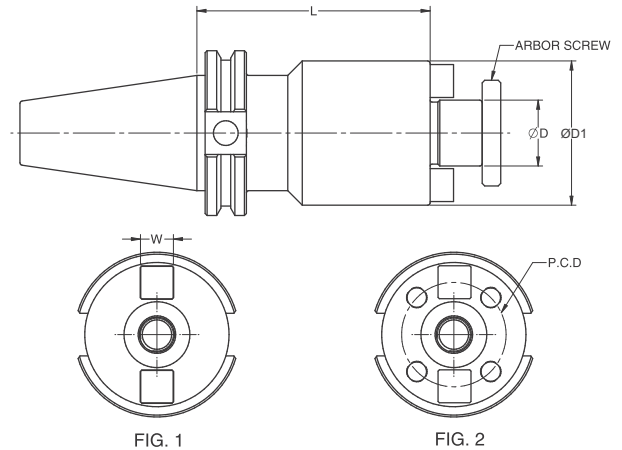

FEATURES

- Balanced to G2.5 @ 25,000 RPM
- T.I.R. < 0.0002"
- Taper shank ground to AT3 accuracy (or better)
- Coolant through center of body

Catalog Number	Description	FIG.	ØD (inch)	L (inch)	ØD1 (inch)	W (inch)	PCD	Arbor Screw	Coolant Style
81265020	CAT50-SMH 0.50-4.00	1	0.50	4.00	1.75	0.250	-	¼-28	AD THRU
81267518	CAT50-SMH 0.75-3.50	1	0.75	3.50	1.75	0.312	-	3/8-24	AD THRU
81267528	CAT50-SMH 0.75-5.50	1	0.75	5.50	1.75	0.312	-	3/8-24	AD THRU
81267541	CAT50-SMH 0.75-8.00	1	0.75	8.00	1.75	0.312	-	3/8-24	AD THRU
84261010	CAT50-SMH 1.00-2.00	1	1.00	2.00	2.19	0.375	-	1/2"-20	AD THRU
81261020	CAT50-SMH 1.00-4.00	1	1.00	4.00	2.19	0.375	-	½-20	AD THRU
81261030	CAT50-SMH 1.00-6.00	1	1.00	6.00	2.19	0.375	-	½-20	AD THRU
81261041	CAT50-SMH 1.00-8.00	1	1.00	8.00	2.19	0.375	-	½-20	AD THRU
81261051	CAT50-SMH 1.00-10.00	1	1.00	10.00	2.19	0.375	-	½-20	AD THRU
81261209	CAT50-SMH 1.25-1.75	1	1.25	1.75	2.75	0.500	-	5/8-18	AD THRU
81261218	CAT50-SMH 1.25-3.50	1	1.25	3.50	2.75	0.500	-	5/8-18	AD THRU
81261230	CAT50-SMH 1.25-6.00	1	1.25	6.00	2.75	0.500	-	5/8-18	AD THRU
80261513	CAT50-SMH 1.50-2.50	1	1.50	2.50	3.94	0.625	-	¾-16	AD THRU
80261520	CAT50-SMH 1.50-4.00	1	1.50	4.00	3.94	0.625	-	¾-16	AD THRU
80261530	CAT50-SMH 1.50-6.00	1	1.50	6.00	3.94	0.625	-	¾-16	AD THRU
80262013	CAT50-SMH 2.00-2.50	1	2.00	2.50	4.44	0.750	-	1-14	AD THRU
80262020	CAT50-SMH 2.00-4.00	1	2.00	4.00	4.44	0.750	-	1-14	AD THRU
80262030	CAT50-SMH 2.00-6.00	1	2.00	6.00	4.44	0.750	-	1-14	AD THRU
802620F13	CAT50-FMH 2.00-2.50	2	2.00	2.50	4.90	0.750	4.0	1-14	AD THRU
802620F20	CAT50-FMH 2.00-4.00	2	2.00	4.00	4.90	0.750	4.0	1-14	AD THRU
802625F13	CAT50-FMH 2.50-2.50	2	2.50	2.50	4.90	1.000	4.0	1-14	AD THRU
802625F20	CAT50-FMH 2.50-4.00	2	2.50	4.00	4.90	1.000	4.0	1-14	AD THRU
81262218	CAT50-SMH 22-90	1	22mm	90mm	45mm	10mm	-	M10xL25*	AD THRU
81262228	CAT50-SMH 22-140	1	22mm	140mm	45mm	10mm	-	M10xL25*	AD THRU

NOTE:

ALL Shell Mill Holders are supplied with coolant through the center up to the arbor screw hole.

* Represents holders provided with metric allen cap bolt.

Retention knobs **on page 198-199**

Non-Coolant and Coolant Arbor Screws **on page 202**

CAT Holders

CAT50 Shell Mill Holder X-Long (ANSI-ASME B5.500-1994)

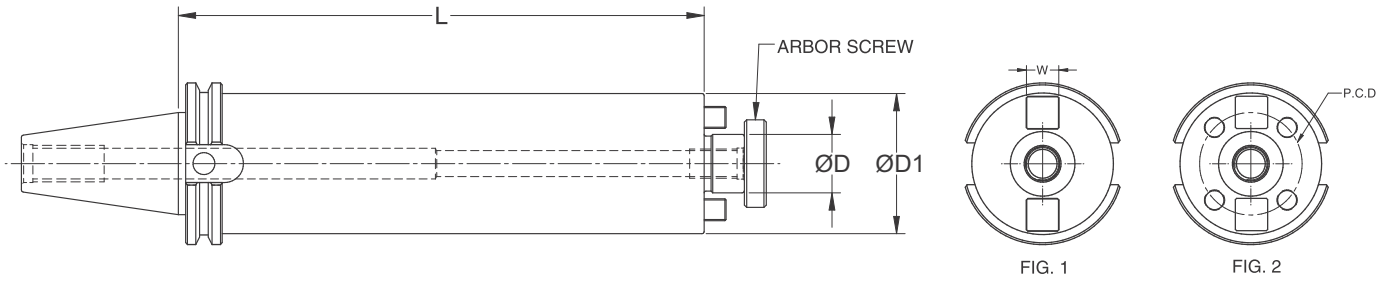

FEATURES

- Balanced to G2.5 @ 25,000 RPM
- T.I.R. < 0.0004"
- Taper shank ground to AT3 accuracy (or better)
- Coolant through center of body

Catalog Number	Description	Fig. No.	ØD (inch)	ØD1 (inch)	L (inch)	W (inch)	PCD	Arbor Screw	Coolant Style
81265030XL	CAT50-SMHXL 0.500-6	1	0.500	1.25	6.00	0.250	-	1/4"-28	AD THRU
81265046XL	CAT50-SMHXL 0.500-9	1	0.500	1.25	9.00	0.250	-	1/4"-28	AD THRU
81267520XL	CAT50-SMHXL 0.750-4	1	0.750	1.90	4.00	0.312	-	3/8"-24	AD THRU
81267530XL	CAT50-SMHXL 0.750-6	1	0.750	1.90	6.00	0.312	-	3/8"-24	AD THRU
81267546XL	CAT50-SMHXL 0.750-9	1	0.750	1.90	9.00	0.312	-	3/8"-24	AD THRU
81267561XL	CAT50-SMHXL 0.750-12	1	0.750	1.90	12.00	0.312	-	3/8"-24	AD THRU
81267576XL	CAT50-SMHXL 0.750-15	1	0.750	1.90	15.00	0.312	-	3/8"-24	AD THRU
81261025XL	CAT50-SMHXL 1.000-5	1	1.000	2.40	5.00	0.375	-	1/2"-20	AD THRU
81261036XL	CAT50-SMHXL 1.000-7	1	1.000	2.40	7.00	0.375	-	1/2"-20	AD THRU
81261051XL	CAT50-SMHXL 1.000-10	1	1.000	2.40	10.00	0.375	-	1/2"-20	AD THRU
81261061XL	CAT50-SMHXL 1.000-12	1	1.000	2.40	12.00	0.375	-	1/2"-20	AD THRU
81261076XL	CAT50-SMHXL 1.000-15	1	1.000	2.40	15.00	0.375	-	1/2"-20	AD THRU
81261230XL	CAT50-SMHXL 1.250-6	1	1.250	2.90	6.00	0.500	-	5/8"-18	AD THRU
81261246XL	CAT50-SMHXL 1.250-9	1	1.250	2.90	9.00	0.500	-	5/8"-18	AD THRU
81261261XL	CAT50-SMHXL 1.250-12	1	1.250	2.90	12.00	0.500	-	5/8"-18	AD THRU
81261276XL	CAT50-SMHXL 1.250-15	1	1.250	2.90	15.00	0.500	-	5/8"-18	AD THRU
80261525XL	CAT50-SMHXL 1.500-5	1	1.500	3.88	5.00	0.625	-	3/4"-16	AD THRU
80261541XL	CAT50-SMHXL 1.500-8	1	1.500	3.88	8.00	0.625	-	3/4"-16	AD THRU
80261561XL	CAT50-SMHXL 1.500-12	1	1.500	3.88	12.00	0.625	-	3/4"-16	AD THRU
80261576XL	CAT50-SMHXL 1.500-15	1	1.500	3.88	15.00	0.625	-	3/4"-16	AD THRU
80262061XL	CAT50-SMHXL 2.00-12	1	2.000	4.38	12.00	0.750	-	1"-14	AD THRU
802620F30XL	CAT50-FMHXL 2.000-6	2	2.000	4.90	6.00	0.750	4.00	1"-14	AD THRU
802625F20XL	CAT50-FMHXL 2.500-4	2	2.500	4.90	4.00	1.000	4.00	1"-14	AD THRU
802625F41XL	CAT50-FMHXL 2.500-8	2	2.500	4.90	8.00	1.000	4.00	1"-14	AD THRU

NOTE:

ALL Shell Mill Holders are supplied with coolant through the center up to the arbor screw hole.

Retention knobs **on page 198-199**

Non-Coolant and Coolant Arbor Screws **on page 202**

CAT Holders

CAT50 ER Collet Holder (ANSI/ASME B5.50-1994)

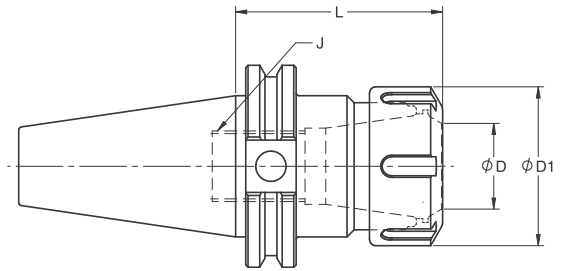

FEATURES

- Balanced to G2.5 @ 25,000 RPM
- T.I.R. < 0.0002"
- Balanced ER Collet Nuts
- AD coolant thru the spindle
- Taper shank ground to AT3 accuracy (or better)

Catalog Number	Description	Collet Size	ϕD Range (inch)	$\phi D1$ (inch)	L (inch)	J (inch)	Coolant Style
87226114	CAT50-CHE 16-2.75	ER16	.118 - .393	1.102	2.75	7/16-16LH	AD Thru
87226120	CAT50-CHE 16-4.00	ER16	.118 - .275	1.102	4.00	7/16-16LH	AD Thru
87226130	CAT50-CHE 16-6.00	ER16	.118 - .275	1.102	6.00	7/16-16LH	AD Thru
87226141	CAT50-CHE 16-8.00	ER16	.118 - .393	1.102	8.00	7/16-16LH	AD Thru
87226151	CAT50-CHE 16-10.00	ER16	.118 - .393	1.102	10.00	7/16-16LH	AD Thru
87226214	CAT50-CHE 20-2.75	ER20	.118 - .511	1.338	2.75	9/16-16LH	AD Thru
87226220	CAT50-CHE 20-4.00	ER20	.118 - .393	1.338	4.00	9/16-16LH	AD Thru
87226230	CAT50-CHE 20-6.00	ER20	.118 - .393	1.338	6.00	9/16-16LH	AD Thru
87226241	CAT50-CHE 20-8.00	ER20	.118 - .511	1.338	8.00	9/16-16LH	AD Thru
87226320	CAT50-CHE 25-4.00	ER25	.118 - .629	1.653	4.00	11/16-16LH	AD Thru
87226330	CAT50-CHE 25-6.00	ER25	.118 - .629	1.653	6.00	11/16-16LH	AD Thru
87226341	CAT50-CHE 25-8.00	ER25	.118 - .629	1.653	8.00	11/16-16LH	AD Thru
87226414	CAT50-CHE 32-2.75	ER32	.118 - .787	1.968	2.75	7/8-16LH	AD Thru
87226420	CAT50-CHE 32-4.00	ER32	.118 - .787	1.968	4.00	7/8-16LH	AD Thru
87226430	CAT50-CHE 32-6.00	ER32	.118 - .787	1.968	6.00	7/8-16LH	AD Thru
87226441	CAT50-CHE 32-8.00	ER32	.118 - .787	1.968	8.00	7/8-16LH	AD Thru
87226451	CAT50-CHE 32-10.00	ER32	.118 - .787	1.968	10.00	7/8-16LH	AD Thru
87226520	CAT50-CHE 40-4.00	ER40	.157 - 1.023	2.480	4.00	1-1/8-16LH	AD Thru
87226530	CAT50-CHE 40-6.00	ER40	.157 - 1.023	2.480	6.00	1-1/8-16LH	AD Thru

ER Collets on page 182-186
 ER Nut Wrenches on page 203
 Retention knobs on page 198-199

CAT Holders

CAT 40/50 TG Collet Holder (ANSI/ASME B5.50-1994)

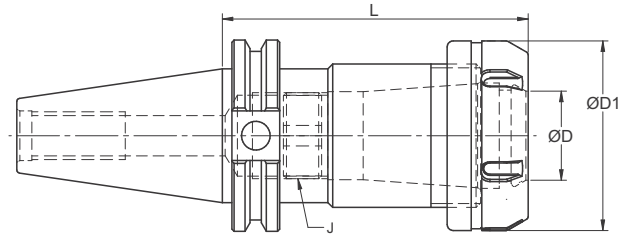

FEATURES

- Balanced to G2.5 @ 25,000 RPM
- T.I.R. < 0.0002"
- Balanced TG Collet Nuts
- AD coolant thru the spindle
- Taper shank ground to AT3 accuracy (or better)

Catalog Number	Description	Collet Size	ØD Range (inch)	ØD1 (inch)	L (inch)	J (inch)	Coolant Style
87324315	CAT40-CHT 100-3.00	TG100	0.250-1.000	2.48	3.00	1.1/8-16LH	AD Thru
87324320	CAT40-CHT 100-4.00	TG100	0.250-1.000	2.48	4.00	1.1/8-16LH	AD Thru
87324330	CAT40-CHT 100-6.00	TG100	0.250-1.000	2.48	6.00	1.1/8-16LH	AD Thru
87326328	CAT50-CHT 100-5.50	TG100	0.250-1.000	2.48	5.50	1.1/8-16LH	AD Thru

Retention knobs on page 198-199

CAT Holders

CAT50 AccuMill™ Multi-Milling Chuck (ANSI-ASME B5.50-1994)

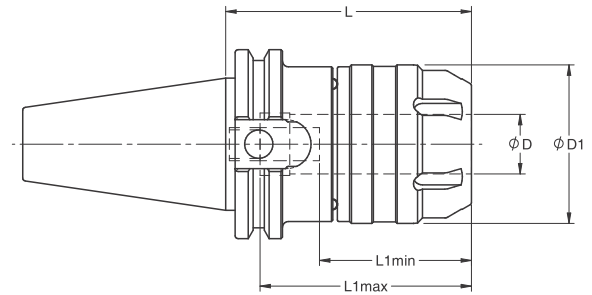

FEATURES

- Balanced to G2.5 @ 25,000 RPM
- T.I.R. < 0.0002"
- Taper shank ground to AT3 accuracy (or better)
- Bore tolerance: H6

	Catalog Number	Description	Collet Size	Collet Capacity Range	ϕD	$\phi D1$	L	L1 Min/Max	Coolant Style
CAT50 Inch	97262816	CAT50-MMC 0.750-3.25	MC75	.125 - .625	0.75	2.09	3.25	2.50/2.75	AD Thru
	97262825	CAT50-MMC 0.750-5.00	MC75	.125 - .625	0.75	2.09	5.00	2.50/2.75	AD Thru
	97262216	CAT50-MMC 1.250-3.25	MC125	.125 - 1.00	1.25	2.64	3.25	3.09/3.38	AD Thru
	97262225	CAT50-MMC 1.250-5.00	MC125	.125 - 1.00	1.25	2.64	5.00	3.09/3.38	AD Thru
CAT50 Metric	97262016	CAT50-MMC 20-80	MC20	3 -- 16	20	53	80	63/70	AD Thru
	97262024	CAT50-MMC 20-120	MC20	3 -- 16	20	53	120	63/70	AD Thru
	97263218	CAT50-MMC 32-90	MC32	3 -- 25	32	67	90	78/85	AD Thru
	97263224	CAT50-MMC 32-120	MC32	3 -- 25	32	67	120	78/85	AD Thru

AccuMill™ Collets on page 191-192 | AccuMill™ Collet Nut wrenches on page 201 | Retention knobs on page 198-199

CAT50 AccuClamp™ Hydraulic Chucks (ANSI/ASME B5.50-1994)

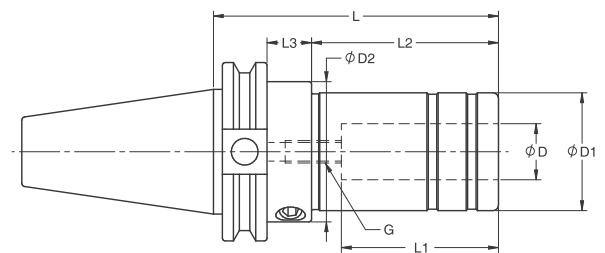

FEATURES

- Balanced to G2.5 @ 25,000 RPM
- T.I.R. < 0.0002"
- Taper shank ground to AT3 accuracy (or better)
- Bore tolerance: H6

	Catalog Number	Description	ϕD (inch)	$\phi D1$ (inch)	$\phi D2$ (inch)	L (inch)	L1 (inch)	L2 (inch)	L3 (inch)	G (inch)	Coolant Style
CAT50 Inch	68262820	CAT50-HCS 0.750-4.00	0.750	1.65	2.05	4.00	2.05	2.28	0.96	M8X1	AD Thru
	68262225	CAT50-HCS 1.250-5.00	1.250	2.36	2.75	5.00	2.44	3.46	0.78	M8X1	AD Thru
CAT50 Metric	68262020	CAT50-HCS 20-100	20mm	42mm	52mm	100mm	52mm	56mm	25mm	M8X1	AD Thru
	68263225	CAT50-HCS 32-125	32mm	60mm	70mm	125mm	60mm	86mm	20mm	M8X1	AD Thru

AccuClamp™ Torque wrenches on page 204 | AccuClamp™ Reduction Sleeves on page 191-192 | Retention knobs on page 198-199

CAT Holders

CAT50 AccuClamp™ Hydraulic Chucks Slim Design (ANSI/ASME B5.50-1994)

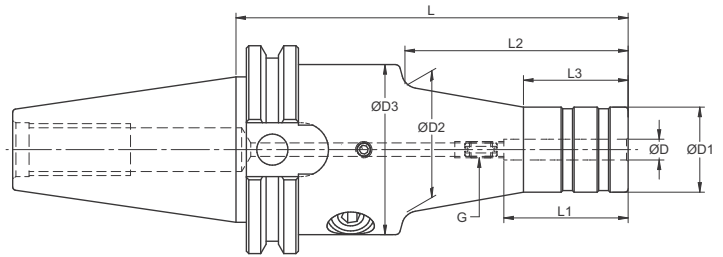

FEATURES

- Balanced to G2.5 @ 25,000 RPM
- T.I.R. < 0.0002"
- Taper shank ground to AT3 accuracy (or better)
- Bore tolerance: H6

Catalog Number	Description	ØD (inch)	ØD1 (inch)	ØD2 (inch)	ØD3 (inch)	L (inch)	L1 (inch)	L2 (inch)	L3 (inch)	G (inch)	Coolant Style
68241124SL	CAT50-HCSL 0.250-4.72	0.250	1.03	1.53	2.50	4.72	1.50	2.68	1.26	M5x0.8	AD Thru
68241324SL	CAT50-HCSL 0.312-4.72	0.312	1.10	1.61	2.50	4.72	1.65	2.68	1.26	M5x0.8	AD Thru
68242624SL	CAT50-HCSL 0.375-4.72	0.375	1.18	1.69	2.50	4.72	1.77	2.68	1.26	M6x1	AD Thru
68241524SL	CAT50 HCSL 0.500-4.72	0.500	1.26	1.77	2.50	4.72	1.81	2.68	1.26	M8x1	AD Thru

AccuClamp™ Torque wrenches **on page 204**
 AccuClamp™ Reduction Sleeves **on page 191-192**
 Retention knobs **on page 198-199**

CAT50 AccuClamp™ Heavy Duty Hydraulic Chucks (ANSI-ASME B5.50-1994)

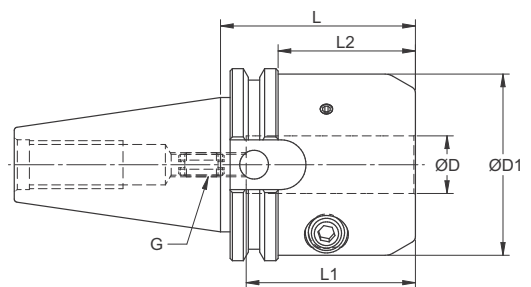

FEATURES

- Balanced to G2.5 @ 25,000 RPM
- T.I.R. < 0.0002"
- Taper shank ground to AT3 accuracy (or better)
- Bore tolerance: H6

Catalog Number	Description	ØD	ØD1	L	L1	L2	G	Coolant Style
67262817	CAT50-HC 0.750-3.25	0.75	2.36	3.25	2.05	2.50	M8x1	AD Thru
67262217	CAT50-HC 1.250-3.25	1.25	2.84	3.25	2.44	2.50	M8x1	AD Thru

AccuClamp™ Torque wrenches **on page 204**
 AccuClamp™ Reduction Sleeves **on page 191-192**
 Retention knobs **on page 198-199**

CAT Holders

CAT50 Morse Taper Holder (ANSI/ASME B5.50-1994)

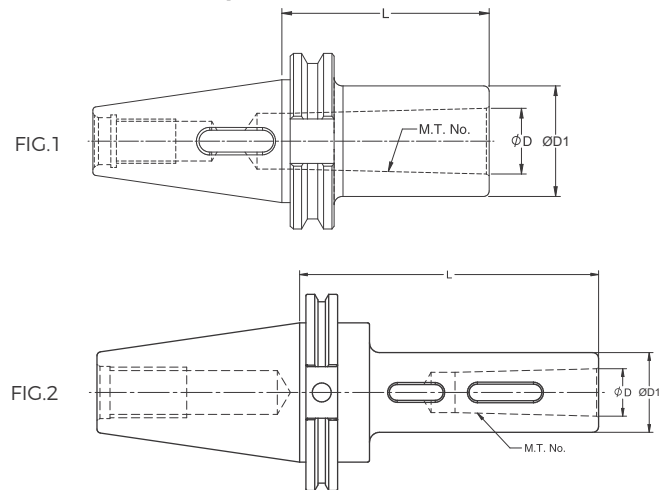

FEATURES

- Balanced to G2.5 @ 25,000 RPM
- T.I.R. < 0.0004"
- Taper shank ground to AT3 accuracy (or better)

Catalog Number	Description	MT Socket	ØD (inch)	L (inch)	ØD1 (inch)	Coolant Style
88026109	CAT50-MTA 1-1.77	1	0.475	1.77	0.98	N/A
88026124	CAT50-MTA 1-4.72	1	0.475	4.72*	0.98	N/A
88026136	CAT50-MTA 1-7.08	1	0.475	7.08*	0.98	N/A
88026209	CAT50-MTA 2-1.77	2	0.700	1.77	1.25	N/A
88026227	CAT50-MTA 2-5.31	2	0.700	5.31*	1.25	N/A
88026236	CAT50-MTA 2-7.08	2	0.700	7.08*	1.25	N/A
88026309	CAT50-MTA 3-1.77	3	0.938	1.77	1.57	N/A
88026330	CAT50-MTA 3-5.90	3	0.938	5.90*	1.57	N/A
88026336	CAT50-MTA 3-7.08	3	0.938	7.08*	1.57	N/A
88026415	CAT50-MTA 4-2.95	4	1.231	2.95	1.97	N/A
88026436	CAT50-MTA 4-7.08	4	1.231	7.08*	1.97	N/A
88026521	CAT50-MTA 5-4.13	5	1.748	4.13	2.55	N/A
88026542	CAT50-MTA 5-8.26	5	1.748	8.26*	2.55	N/A

Retention knobs on page 198-199

NOTE: * Fig. 2 style above

CAT50 Jacob Taper Holder (ANSI-ASME B5.5-1994)

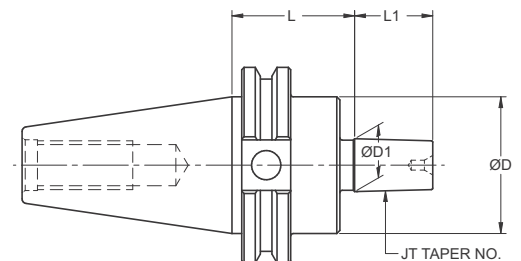
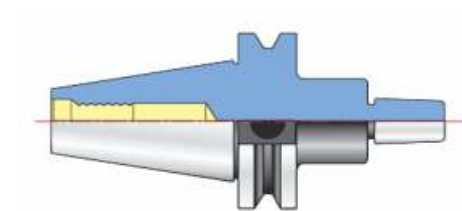

FEATURES

- Balanced to G2.5 @ 25,000 RPM
- Taper shank ground to AT3 accuracy (or better)

Catalog Number	Description	JT Taper No.	L	L1	ØD	ØD1
88426208	CAT50-JTA 2-1.57	2	1.57	0.875	2.75	0.559
88426308	CAT50-JTA 3-1.57	3	1.57	1.129	2.75	0.811
88426408	CAT50-JTA 4-1.57	4	1.57	1.656	2.75	1.124
88426608	CAT50-JTA 6-1.57	6	1.57	1.000	2.75	0.676
884263308	CAT50-JTA 33-1.57	33	1.57	1.000	2.75	0.624

CAT Holders

CAT ER-Z Short Collet Chuck (ANSI/ASME B5.50-1994)

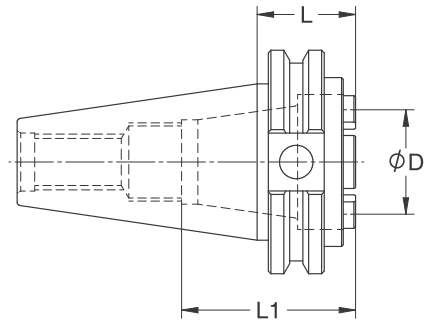
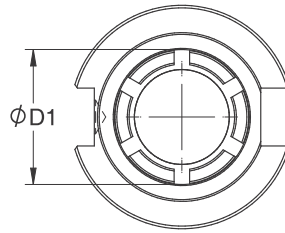

FEATURES

- Balanced to G2.5 @ 25,000 RPM
- T.I.R. < 0.0002"
- Taper shank ground to AT3 accuracy (or better)

	Catalog Number	Description	Collet Size	ϕD Range (inch)	$\phi D1$ (inch)	L (inch)	L1 (inch)	Coolant Style
CAT40	872Z24406	CAT40-CHEZ 32-1.10	ER32	.118 - .787	1.26	1.10	1.34	AD Thru
CAT50	872Z26406	CAT50-CHEZ 32-1.10	ER32	.118 - .787	1.26	1.10	1.34	AD Thru

BT ER-Z Short Collet Chuck (MAS 403)

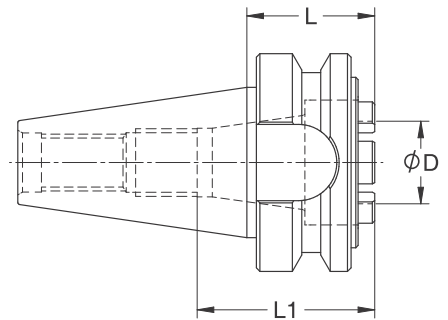
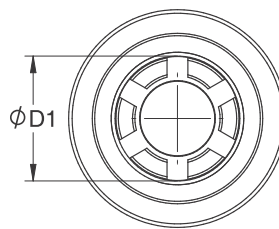

FEATURES

- Balanced to G2.5 @ 25,000 RPM
- T.I.R. < 0.0002"
- Taper shank ground to AT3 accuracy (or better)

	Catalog Number	Description	Collet Size	ϕD Range (inch)	$\phi D1$ (inch)	L (inch)	L1 (inch)	Coolant Style
BT30	872Z10205	BT30-CHEZ 20-27	ER20	.118 - .511	1.10	1.06	1.41	AD Thru
BT40	872Z12407	BT40-CHEZ 32-36	ER32	.118 - .787	1.26	1.47	1.71	AD Thru

ER Collets on page 182-186
 ER-Z Nut Wrenches on page 203
 ER-Z Nut on page 184
 Retention knobs on page 198-199

CATP AccuPlus™ Face Contact Holders

CATP40 Face Contact End Mill Holder

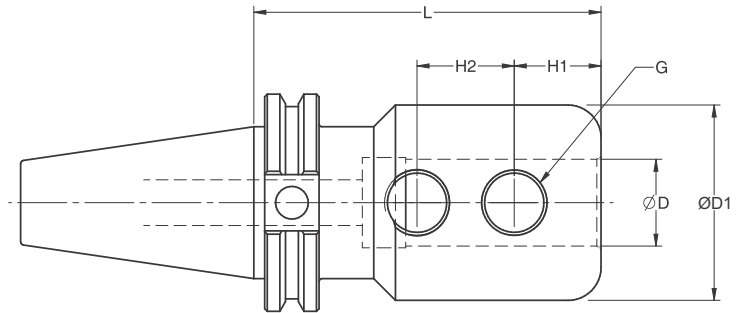

FEATURES

- Balanced to G2.5 @ 25,000 RPM
- T.I.R. < 0.0004"
- Taper shank ground to AT3 accuracy (or better)
- Bore tolerance: H6

	Catalog Number	Description	ØD (inch)	L (inch)	ØD1 (inch)	H1	H2	G	Coolant Style
CATP40	841360713	CATP40-EMH 0.125-2.50	0.125	2.50	0.50	0.22	-	10-32	AD Thru
	841360723	CATP40-EMH 0.125-4.50	0.125	4.50	0.50	0.22	-	10-32	AD Thru
	841360913	CATP40-EMH 0.187-2.50	0.187	2.50	0.69	0.56	-	10-32	AD Thru
	841361113	CATP40-EMH 0.250-2.50	0.250	2.50	0.69	0.56	-	1/4"-28	AD Thru
	841361123	CATP40-EMH 0.250-4.50	0.250	4.50	0.69	0.56	-	1/4"-28	AD Thru
	841361313	CATP40-EMH 0.312-2.50	0.312	2.50	1.00	0.75	-	1/4"-28	AD Thru
	841362613	CATP40-EMH 0.375-2.50	0.375	2.50	1.00	0.75	-	3/8"-24	AD Thru
	841362626	CATP40-EMH 0.375-5.00	0.375	5.00	1.00	0.75	-	3/8"-24	AD Thru
	841362713	CATP40-EMH 0.437-2.50	0.437	2.50	1.00	0.88	-	3/8"-24	AD Thru
	841362723	CATP40-EMH 0.437-4.50	0.437	4.50	1.00	0.88	-	3/8"-24	AD Thru
	841361509	CATP40-EMH 0.500-1.75	0.500	1.75	1.75	0.88	-	7/16"-20	AD Thru
	841361516	CATP40-EMH 0.500-3.00	0.500	3.00	1.25	0.88	-	7/16"-20	AD Thru
	841361523	CATP40-EMH 0.500-4.50	0.500	4.50	1.25	0.88	-	7/16"-20	AD Thru
	841363313	CATP40-EMH 0.562-2.50	0.562	2.50	1.25	0.94	-	1/2"-20	AD Thru
	841363323	CATP40-EMH 0.562-4.50	0.562	4.50	1.25	0.94	-	1/2"-20	AD Thru
	841361716	CATP40-EMH 0.625-3.00	0.625	3.00	1.50	0.94	-	9/16"-18	AD Thru
	841361723	CATP40-EMH 0.625-4.50	0.625	4.50	1.62	0.94	-	9/16"-18	AD Thru
	841361730	CATP40-EMH 0.625-5.75	0.625	5.75	1.62	0.94	-	9/16"-18	AD Thru
	841362809	CATP40-EMH 0.750-1.75	0.750	1.75	1.75	1.00	-	5/8"-18	AD Thru
	841362816	CATP40-EMH 0.750-3.00	0.750	3.00	1.75	1.00	-	5/8"-18	AD Thru
841362823	CATP40-EMH 0.750-4.5	0.750	4.50	1.75	1.00	-	5/8"-18	AD Thru	
841362116	CATP40-EMH 1.000-3.00	1.000	3.00	1.95	0.88	1.00	3/4"-16*	AD Thru	
841362123	CATP40-EMH 1.000-4.50	1.000	4.50	2.25	1.00	1.12	3/4"-16*	AD Thru	
841362223	CATP40-EMH 1.250-4.50	1.250	4.50	2.25	1.00	1.12	3/4"-16*	AD Thru	
841362326	CATP40-EMH 1.500-5.00	1.500	5.00	2.75	1.12	1.00	3/4"-16*	AD Thru	

NOTE: Available in IK2 Coolant Port Style Holders

Retention knobs on page 198-199

CATP AccuPlus™ Face Contact Holders

CATP40 Face Contact ER Collet Holder

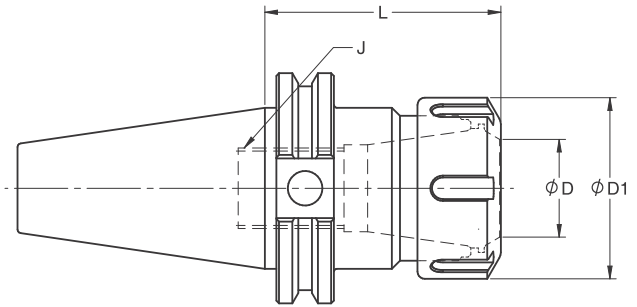

FEATURES

- Balanced to G2.5 @ 25,000 RPM
- AD coolant thru the spindle
- Balanced ER Collet Nuts
- Taper shank ground to AT3 accuracy (or better)
- T.I.R. < 0.0002

	Catalog Number	Description	Collet Size	ϕD Range inch	$\phi D1$ (inch)	L (inch)	J Adj. Screw	Coolant Style
CATP40	872136016	CATP40-CHE 11-3.00	ER11	.118 - .275	0.748	3.00	5/16-24LH	AD Thru
	872136116	CATP40-CHE 16-3.00	ER16	.118 - .393	1.102	3.00	7/16-16LH	AD Thru
	872136131	CATP40-CHE 16-6.00	ER16	.118 - .393	1.102	6.00	7/16-16LH	AD Thru
	872136216	CATP40-CHE 20-3.00	ER20	.118 - .511	1.338	3.00	9/16-16LH	AD Thru
	872136231	CATP40-CHE 20-6.00	ER20	.118 - .511	1.338	6.00	9/16-16LH	AD Thru
	872136241	CATP40-CHE 20-8.00	ER20	.118 - .511	1.338	8.00	9/16-16 LH	AD Thru
	872136316	CATP40-CHE 25-3.00	ER25	.118 - .629	1.653	3.00	11/16-16LH	AD Thru
	872136321	CATP40-CHE 25-4.00	ER25	.118 - .629	1.653	4.00	11/16-16LH	AD Thru
	872136331	CATP40-CHE 25-6.00	ER25	.118 - .629	1.653	6.00	11/16-16LH	AD Thru
	872136416	CATP40-CHE 32-3.00	ER32	.118 - .787	1.968	3.00	7/8-16LH	AD Thru
	872136431	CATP40-CHE 32-6.00	ER32	.118 - .787	1.968	6.00	7/8-16LH	AD Thru
	872136441	CATP40-CHE 32-8.00	ER32	.118 - .787	1.968	8.00	7/8-16 LH	AD Thru
	872136616	CATP40-CHE 40-3.15	ER40	.118 - 1.023	2.408	3.15	1.1/8-16 LH	AD Thru

ER Collets **on page 182-186**

ER Nut Wrenches **on page 203**

Retention knobs **on page 198-199**

CATP AccuPlus™ Face Contact Holders

CATP40 Face Contact Shell Mill Holder

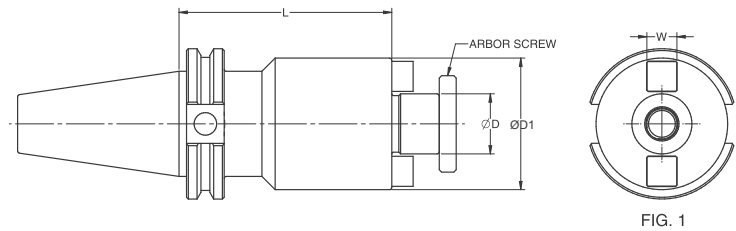

FIG. 1

FEATURES

- Balanced to G2.5 @ 25,000 RPM
- AD coolant thru the spindle with coolant through the center of body
- < 0.0002"
- Taper shank ground to AT3 accuracy (or better)

	Catalog Number	Description	ØD (inch)	L (inch)	ØD1 (inch)	W (inch)	Coolant Style
CATP40	811365011	CATP40-SMH 0.500-2.00	0.500	2.00	1.75	0.250	AD Thru
	811365021	CATP40-SMH 0.500-4.00	0.500	4.00	1.75	0.250	AD Thru
	811367511	CATP40-SMH 0.750-2.00	0.750	2.00	1.75	0.312	AD Thru
	811367521	CATP40-SMH 0.750-4.00	0.750	4.00	1.75	0.312	AD Thru
	811367531	CATP40-SMH 0.750-6.00	0.750	6.00	1.75	0.312	AD Thru
	811367541	CATP40-SMH 0.750-8.00	0.750	8.00	1.75	0.312	AD Thru
	811361012	CATP40-SMH 1.000-2.36	1.000	2.36	2.19	0.375	AD Thru
	811361011	CATP40-SMH 1.000-2.00	1.000	2.00	2.19	0.375	AD Thru
	811361021	CATP40-SMH 1.000-4.00	1.000	4.00	2.19	0.375	AD Thru
	811361031	CATP40-SMH 1.000-6.00	1.000	6.00	2.19	0.375	AD Thru
	811361211	CATP40-SMH 1.250-2.00	1.250	2.00	2.75	0.500	AD Thru
	811361221	CATP40-SMH 1.250-4.00	1.250	4.00	2.75	0.500	AD Thru
	811361231	CATP40-SMH 1.250-6.00	1.250	6.00	2.75	0.500	AD Thru
	811361511	CATP40-SMH 1.500-2.00	1.500	2.00	3.38	0.625	AD Thru
	811361513	CATP40-SMH 1.500-2.50	1.500	2.50	3.38	0.625	AD Thru
	811361521	CATP40-SMH 1.500-4.00	1.500	4.00	3.38	0.625	AD Thru
811362021	CATP40-SMH 2.000-4.00	2.000	4.00	4.44	0.750	AD Thru	

NOTE: ALL Shell Mill Holders are supplied with coolant through the center up to the arbor screw hole.
Retention knobs [on page 198-199](#) | Non-Coolant and Coolant Arbor Screws [on page 202](#)

CATP40 Face Contact AccuClamp™ Hydraulic Chucks

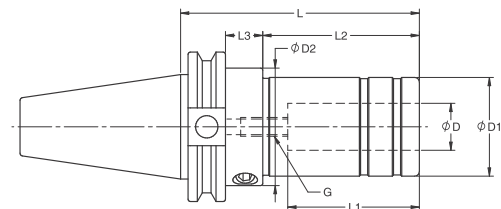

FEATURES

- Balanced to G2.5 @ 25,000 RPM
- T.I.R. < 0.0002"
- Taper shank ground to AT3 accuracy (or better)
- Bore tolerance: H6

	Catalog Number	Description	ØD (inch)	ØD1 (inch)	ØD2 (inch)	L (inch)	L1 (inch)	L2 (inch)	L3 (inch)	G (inch)	Coolant Style
CATP40	681362820	CATP40-HCS 0.750-4.00	0.750	1.65	2.05	4.00	2.05	2.28	0.96	M8x1	AD Thru
	681362223	CATP40-HCS 1.250-4.52	1.250	2.36	2.36	4.52	2.44	3.78	-	M8x1	AD Thru

AccuClamp™ Torque wrenches [on page 204](#) | AccuClamp™ Reduction Sleeves [on page 191-192](#) | Retention knobs [on page 198-199](#)

CATP AccuPlus™ Face Contact Holders

CATP40 Face Contact AccuMill™ Multi-Milling Chucks

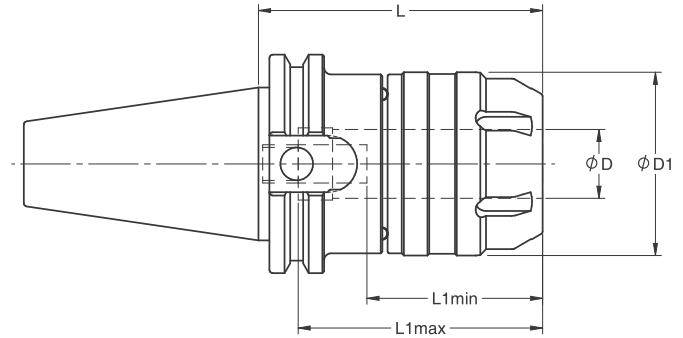

FEATURES

- Balanced to G2.5 @ 25,000 RPM
- T.I.R. < 0.0002"
- Bore Tolerance: H6
- Taper shank ground to AT3 accuracy (or better)

	Catalog Number	Description	Collet Size	Collet Capacity Range	ϕD	$\phi D1$	L	L1 Min.	L1 Max.	Coolant Style
CATP40	971362018	CATP40-MMC 20-90	MC20	3 -- 16	20	53	90	63	70	Thru
	971363220	CATP40-MMC 32-100	MC32	3 -- 25	32	74	100	78	85	Thru
	971362818	CATP40-MMC 0.750-3.50	MC 0.750	.125 - .625	0.75	2.09	3.50	2.50	2.75	Thru
	971362825	CATP40-MMC 0.750-5.00	MC 0.750	.125 - .625	0.75	2.09	5.00	2.50	2.75	Thru
	971362218	CATP40-MMC 1.250-3.50	MC 1.250	.125 - 1.00	1.25	2.64	3.50	3.09	3.34	Thru
	971362225	CATP40-MMC 1.250-5.00	MC 1.250	.125 - 1.00	1.25	2.64	5.00	3.09	3.34	Thru

AccuMill™ Collets on page 191-192

AccuMill™ Collet Nut wrenches on page 201

Retention knobs on page 198-199

Accutek Manufacturing Tip #1

Checking Drawbar force - It is critical that your PM (Preventive Maintenance) Program includes a regularly scheduled (at minimum every 90 days) inspection and check of the drawbar pulling force in your spindle. All machining centers use a drawbar that has spring packs that PULL the TOOLHOLDER back into the SPINDLE. Only mechanical pressure is used to push the drawbar "out" to release a tool shank during tool changes. This PULLBACK pressure created by the spring packs will wear or fatigue over time and the proper PULLBACK pressure will weaken. This loss of pressure allows the shank of your tool holder to move "out" of the spindle socket with radial load. There is a min/max pressure point for every brand of machine and type of spindle. Making sure your PULL BACK pressure is maintained within the proper range is critical to your machining processes, tool holder and cutting tool wear, spindle surface wear, and spindle bearing life. The process takes no more than 10-15 minutes to complete. Using a quality Drawbar Force Gauge fitted with the proper shank for your machine, hand load the Drawbar Force gauge into your spindle and let the drawbar pull it back into the spindle socket. The reading on the indicator will tell you what your drawbar force pressure is currently at vs. what should be maintained. If it is out of proper specifications, then have a certified maintenance person make the adjustment to bring the pressure back into the proper range.

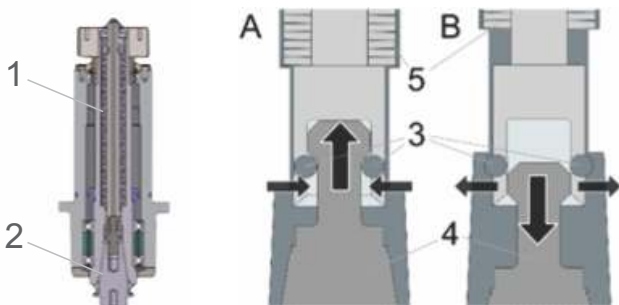

This OTT Drawbar assembly is out non-motorized Franz Kessler spindle

Microscopic examination shows that it is riddled with fatigue fracture lines.

It is SOP at HST to always replace all drawbar springs.



Images courtesy of HAAS Automation



Images courtesy of OTT Spindle

CATP AccuPlus™ Face Contact Holders

CATP40 Face Contact AccuClamp™ Hydraulic Chucks Slim Design

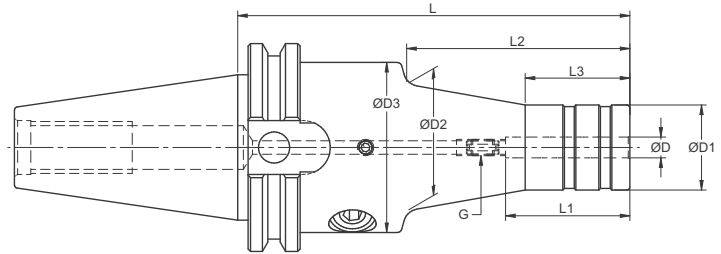

FEATURES

- Balanced to G2.5 @ 25,000 RPM
- T.I.R. < 0.0002"
- Taper shank ground to AT3 accuracy (or better)
- Bore tolerance: H6

Catalog Number	Description	ØD (inch)	ØD1 (inch)	ØD2 (inch)	ØD3 (inch)	L (inch)	L1 (inch)	L2 (inch)	L3 (inch)	G (inch)	Coolant Style
681361124SL	CATP40-HCSL 0.250-4.72	0.250	1.03	1.53	2.05	4.72	1.50	2.68	1.26	M5x0.8	AD Thru
681361324SL	CATP40-HCSL 0.312-4.72	0.312	1.10	1.61	2.05	4.72	1.65	2.68	1.26	M5x0.8	AD Thru
681362624SL	CATP40-HCSL 0.375-4.72	0.375	1.18	1.69	2.05	4.72	1.77	2.68	1.26	M6x1	AD Thru
681361524SL	CATP40 HCSL 0.500-4.72	0.500	1.26	1.77	2.05	4.72	1.81	2.68	1.26	M8x1	AD Thru

AccuClamp™ Torque wrenches [on page 204](#)

AccuClamp™ Reduction Sleeves [on page 191-192](#)

Retention knobs [on page 198-199](#)

CATP40 Face Contact AccuClamp™ Heavy Duty Hydraulic Chucks

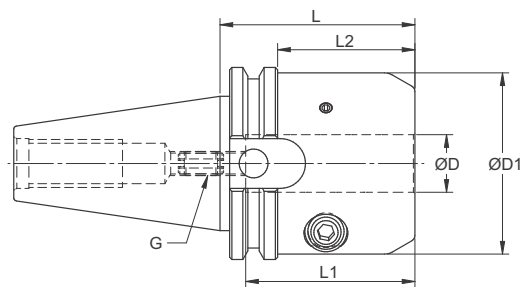

FEATURES

- Balanced to G2.5 @ 25,000 RPM
- T.I.R. < 0.0002"
- Taper shank ground to AT3 accuracy (or better)
- Bore tolerance: H6

Catalog Number	Description	ØD	ØD1	L	L1	L2	G	Coolant Style
671362813	CATP40-HC 0.750-2.50	0.75	2.36	2.50	2.05	1.75	M8x1	AD Thru
671362217	CATP40-HC 1.250-3.25	1.25	2.84	3.25	2.44	2.50	M8x1	AD Thru

AccuClamp™ Torque wrenches [on page 204](#)

AccuClamp™ Reduction Sleeves [on page 191-192](#)

Retention knobs [on page 198-199](#)

CATP AccuPlus™ Face Contact Holders

CATP50 Face Contact End Mill Holder (1835 B)

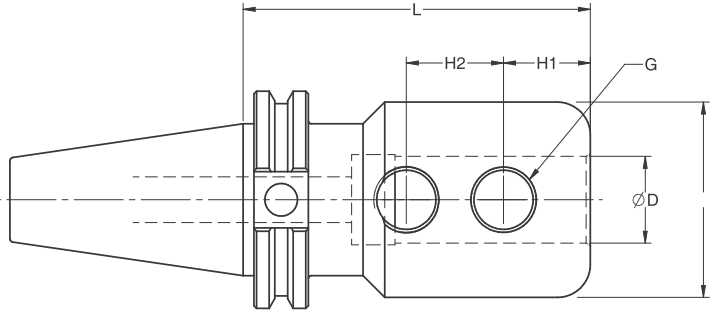

FEATURES

- Balanced to G2.5 @ 25,000 RPM
- T.I.R. < 0.0004"
- Taper shank ground to AT3 accuracy (or better)
- AD coolant thru the spindle
- Bore Tolerance: H6

	Catalog Number	Description	ØD (inch)	L (inch)	C (inch)	H1	H2	G	Coolant Style
CATP50 Inch	841381123	CATP50-EMH 0.250-4.50	0.250	4.50	0.69	0.56	-	1/4"-28	AD Thru
	841381130	CATP50-EMH 0.250-6.00	0.250	6.00	0.69	0.56	-	1/4"-28	AD Thru
	841382613	CATP50-EMH 0.375-2.50	0.375	2.50	1.00	0.75	-	3/8"-24	AD Thru
	841382623	CATP50-EMH 0.375-4.50	0.375	4.50	1.00	0.75	-	3/8"-24	AD Thru
	841382631	CATP50-EMH 0.375-6.00	0.375	6.00	1.00	0.75	-	3/8"-24	AD Thru
	841381523	CATP50-EMH 0.500-4.50	0.500	4.50	1.38	0.88	-	7/16"-20	AD Thru
	841381531	CATP50-EMH 0.500-6.00	0.500	6.00	1.38	0.88	-	7/16"-20	AD Thru
	841382823	CATP50-EMH 0.750-4.50	0.750	4.50	1.75	1.00	-	5/8"-18	AD Thru
	841382831	CATP50-EMH 0.750-6.00	0.750	6.00	1.75	1.00	-	5/8"-18	AD Thru
	841382123	CATP50-EMH 1.000-4.50	1.000	4.50	2.25	1.12	1.00	3/4"-16*	AD Thru
	841382131	CATP50-EMH 1.000-6.00	1.000	6.00	2.25	1.12	1.00	3/4"-16*	AD Thru
	841382141	CATP50-EMH 1.000-8.00	1.000	8.00	2.25	1.12	1.00	3/4"-16*	AD Thru
	841382222	CATP50-EMH 1.250-4.25	1.250	4.25	2.50	1.12	1.00	3/4"-16*	AD Thru
	841382231	CATP50-EMH 1.250-6.00	1.250	6.00	2.50	1.12	1.00	3/4"-16*	AD Thru
	841382241	CATP50-EMH 1.250-8.00	1.250	8.00	2.50	1.12	1.00	3/4"-16*	AD Thru
	841382323	CATP50-EMH 1.500-4.50	1.500	4.50	2.75	1.12	1.00	3/4"-16*	AD Thru
841382331	CATP50-EMH 1.500-6.00	1.500	6.00	2.75	1.12	1.00	3/4"-16*	AD Thru	
841382341	CATP50-EMH 1.500-8.00	1.500	8.00	2.75	1.12	1.00	3/4"-16*	AD Thru	
841382931	CATP50-EMH 2.000-6.00	2.000	6.00	3.75	1.38	1.50	1--14*	AD Thru	
841383131	CATP50-EMH 2.500-6.00	2.500	6.00	4.25	1.56	1.69	1--14*	AD Thru	
CATP50 Metric	841380623	CATP50-EMH 6-115	6 mm	115 mm	25 mm	18 mm	-	M6x1	AD Thru
	841380823	CATP50-EMH 8-115	8 mm	115 mm	28 mm	18 mm	-	M8x1.25	AD Thru
	841381819	CATP50-EMH 18-95	18 mm	95 mm	50 mm	24 mm	-	M14x2	AD Thru
	841383220	CATP50-EMH 32-100	32 mm	100 mm	72 mm	22 mm	24 mm	M20x2	AD Thru

Available in IK2 Coolant Port Style Holders

Retention knobs on page 198-199

CATP AccuPlus™ Face Contact Holders

CATP50 Face Contact ER Collet Holder

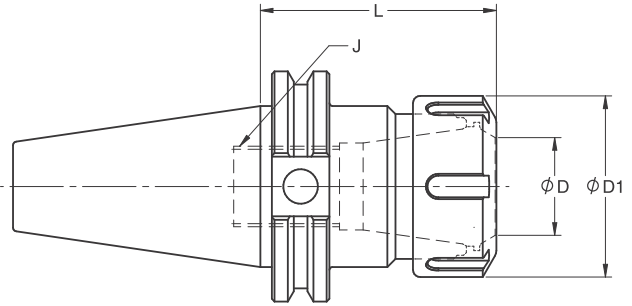

FEATURES

- Balanced to G2.5 @ 25,000 RPM
- T.I.R. < 0.0002"
- Taper shank ground to AT3 accuracy (or better)
- Balanced ER Collet Nuts

	Catalog Number	Description	Collet Size	ØD Range inch	ØD1 (inch)	L (inch)	J Adj. Screw	Coolant Style
CATP50	872138121	CATP50-CHE 16-4.00	ER16	.118 - .275	0.748	4.00	7/16-16LH	AD Thru
	872138131	CATP50-CHE 16-6.00	ER16	.118 - .275	0.748	6.00	7/16-16LH	AD Thru
	872138221	CATP50-CHE 20-4.00	ER20	.118 - .511	1.102	4.00	9/16-16LH	AD Thru
	872138231	CATP50-CHE 20-6.00	ER20	.118 - .511	1.102	6.00	9/16-16LH	AD Thru
	872138321	CATP50-CHE 25-4.00	ER25	.118 - .629	1.653	4.00	11/16-16LH	AD Thru
	872138331	CATP50-CHE 25-6.00	ER25	.118 - .629	1.653	6.00	11/16-16LH	AD Thru
	872138421	CATP50-CHE 32-4.00	ER32	.118 - .787	1.968	4.00	7/8-16LH	AD Thru
	872138431	CATP50-CHE 32-6.00	ER32	.118 - .787	1.968	6.00	7/8-16LH	AD Thru
	872138441	CATP50-CHE 32-8.00	ER32	.118 - .787	1.968	8.00	7/8-16LH	AD Thru
	872138521	CATP50-CHE 40-4.00	ER40	.157 - 1.023	2.480	4.00	1.1/8-16LH	AD Thru

ER Collets [on page 182-186](#)

ER Nut Wrenches [on page 203](#)

Retention knobs [on page 198-199](#)

Accutek Manufacturing Tip #2

TIR (Total Indicator Run-out) is critical to your manufacturing processes. TIR accuracy has a direct impact on cutting edge tool life, machined part finish, machined surface dimensional accuracy, and spindle bearing life. When selecting your tool holder style and brand, make sure you are getting the best TIR accuracy from your holder assembly.

Things that impact TIR accuracy:

- 1) Tool holder manufactured quality
- 2) Tool shank care and cleanliness
- 3) Spindle care and cleanliness
- 4) Torque on collet nut, mill chuck nut, and torque on hydraulic pressure screw
- 5) Cleanliness of tool holder and cutting tool assembly

CATP AccuPlus™ Face Contact Holders

CATP50 Face Contact Shell Mill Holder

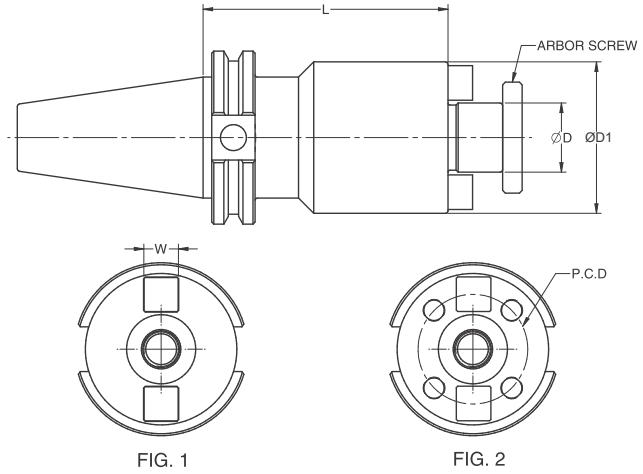

FEATURES

- Balanced to G2.5 @ 25,000 RPM
- Taper shank ground to AT3 accuracy (or better)
- T.I.R. < 0.0002"
- Coolant through the center of the body

	Catalog Number	Fig. No.	Description	ØD (inch)	L (inch)	ØD1 (inch)	W (inch)	P.C.D.	Coolant Style
CATP50	811387511	1	CATP50-SMH 0.750-2.00	0.75	2.00	1.75	0.312	-	AD Thru
	811387521	1	CATP50-SMH 0.750-4.00	0.75	4.00	1.75	0.312	-	AD Thru
	811387531	1	CATP50-SMH 0.750-6.00	0.75	6.00	1.75	0.312	-	AD Thru
	811381011	1	CATP50-SMH 1.00-2.00	1.00	2.00	2.19	0.375	-	AD Thru
	811381021	1	CATP50-SMH 1.00-4.00	1.00	4.00	2.19	0.375	-	AD Thru
	811381031	1	CATP50-SMH 1.00-6.00	1.00	6.00	2.19	0.375	-	AD Thru
	811381041	1	CATP50-SMH 1.00-8.00	1.00	8.00	2.19	0.375	-	AD Thru
	811381051	1	CATP50-SMH 1.00-10.00	1.00	10.00	2.19	0.375	-	AD Thru
	811381061	1	CATP50-SMH 1.00-12.00	1.00	12.00	2.19	0.375	-	AD Thru
	811381211	1	CATP50-SMH 1.25-2.00	1.25	2.00	2.75	0.500	-	AD Thru
	811381221	1	CATP50-SMH 1.25-4.00	1.25	4.00	2.75	0.500	-	AD Thru
	811381231	1	CATP50-SMH 1.25-6.00	1.25	6.00	2.75	0.500	-	AD Thru
	811381241	1	CATP50-SMH 1.25-8.00	1.25	8.00	2.75	0.500	-	AD Thru
	811381251	1	CATP50-SMH 1.25-10.00	1.25	10.00	2.75	0.500	-	AD Thru
	811381261	1	CATP50-SMH 1.25-12.00	1.25	12.00	2.75	0.500	-	AD Thru
	811381523	1	CATP50-SMH 1.50-4.50	1.50	4.50	3.94	0.625	-	AD Thru
	811381511	1	CATP50-SMH 1.50-2.00	1.50	2.00	3.94	0.625	-	AD Thru
	811381521	1	CATP50-SMH 1.50-4.00	1.50	4.00	3.94	0.625	-	AD Thru
	811381531	1	CATP50-SMH 1.50-6.00	1.50	6.00	3.94	0.625	-	AD Thru
	811381541	1	CATP50-SMH 1.50-8.00	1.50	8.00	3.94	0.625	-	AD Thru
	811381551	1	CATP50-SMH 1.50-10.00	1.50	10.00	3.94	0.625	-	AD Thru
	811381561	1	CATP50-SMH 1.50-12.00	1.50	12.00	3.94	0.625	-	AD Thru
	8113820F13	2	CATP50-FMH 2.00-2.50	2.00	2.50	4.90	0.750	4.0	AD Thru
	8113820F21	2	CATP50-FMH 2.00-4.00	2.00	4.00	4.90	0.750	4.0	AD Thru
	8113825F13	2	CATP50-FMH 2.50-2.50	2.50	2.50	4.90	1.000	4.0	AD Thru
	8113825F20	2	CATP50-FMH 2.50-4.00	2.50	4.00	4.90	1.000	4.00	AD Thru
	811381621	2	CATP50-SMH 16-4.00	16 mm	101.6 mm	36 mm	8 mm	-	AD Thru
	811381641	2	CATP50-SMH 16-8.00	16 mm	203.2 mm	36 mm	8 mm	-	AD Thru
	811382241	2	CATP50-SMH 22-8.00	22 mm	203.2 mm	48 mm	10 mm	-	AD Thru
	811383224	2	CATP50-SMH 32-120	32 mm	120 mm	78 mm	14 mm	-	AD Thru

NOTE:

ALL Shell Mill Holders are supplied with coolant through the center up to the arbor screw hole.

* Represents holders provide with metric allen cap bolt.

Retention knobs **on page 198-199**

Non-Coolant and Coolant Arbor Screws **on page 202**

CATP AccuPlus™ Face Contact Holders

CATP50 Face Contact AccuMill™ Multi-Milling Chucks

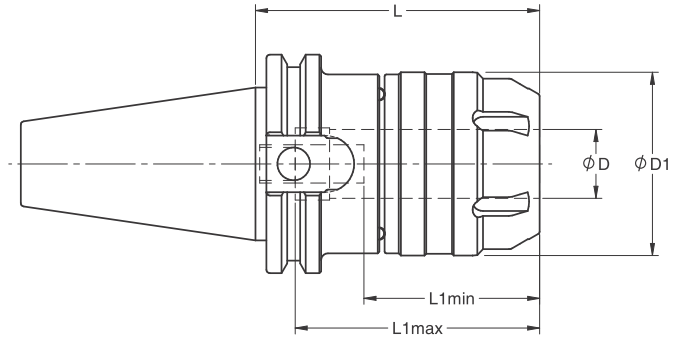

FEATURES

- Balanced to G2.5 @ 25,000 RPM
- T.I.R. < 0.0002"
- Taper shank ground to AT3 accuracy (or better)
- Bore tolerance: H6

	Catalog Number	Description	Collet Size	Collet Capacity Range	ϕD	$\phi D1$	L	L1 Min.	L1 Max.	Coolant Style
CATP50 Metric	971382021	CATP50-MMC 20-105	MC20	3 - 16	20	53	105	63	70	AD Thru
	971383221	CATP50-MMC 32-105	MC32	3 - 25	32	67	105	78	85	AD Thru
CATP50 Inch	971382817	CATP50-MMC 0.750-3.25	MC 0.750	.125 - .625	0.75	2.09	3.25	2.50	2.75	AD Thru
	971382825	CATP50-MMC 0.750-5.00	MC 0.750	.125 - .625	0.75	2.09	5.00	2.50	2.75	AD Thru
	971382217	CATP50-MMC 1.250-3.25	MC 1.250	.125 - 1.00	1.25	2.64	3.25	3.09	3.34	AD Thru
	971382225	CATP50-MMC 1.250-5.00	MC 1.250	.125 - 1.00	1.25	2.64	5.00	3.09	3.34	AD Thru

AccuMill™ Collets [on page 191-192](#) | AccuMill™ Collet Nut wrenches [on page 201](#) | Retention knobs [on page 198-199](#)

CATP50 Face Contact AccuClamp™ Hydraulic Chucks

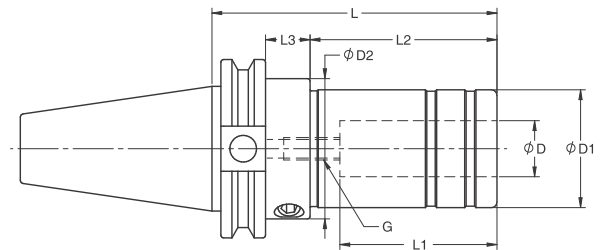

FEATURES

- Balanced to G2.5 @ 25,000 RPM
- T.I.R. < 0.0002"
- Taper shank ground to AT3 accuracy (or better)
- Bore tolerance: H6

	Catalog Number	Description	ϕD (inch)	$\phi D1$ (inch)	$\phi D2$ (inch)	L (inch)	L1 (inch)	L2 (inch)	L3 (inch)	G (inch)	Coolant Style
CATP50 Inch	681382820	CATP50-HCS 0.750-4.00	0.750	1.65	2.05	4.00	2.05	2.28	0.96	M8x1	AD Thru
	681382225	CATP50-HCS 1.250-5.00	1.250	2.36	2.75	5.00	2.44	3.46	0.78	M8x1	AD Thru
CATP50 Metric	681382020	CATP50-HCS 20-100	20.000	42	52	100	52	56.4	24.5	M8x1	AD Thru
	681382520	CATP50-HCS 25-100	25.000	52	69.85	100	52	56.4	24.5	M8x1	AD Thru
	681383225	CATP50-HCS 32-125	32.000	60	69.85	125	60	85.9	20	M8x1	AD Thru

AccuClamp™ Torque wrenches [on page 204](#) | AccuClamp™ Reduction Sleeves [on page 191-192](#) | Retention knobs [on page 198-199](#)

CATP AccuPlus™ Face Contact Holders

CATP50 Face Contact AccuClamp™ Hydraulic Chucks Slim Design

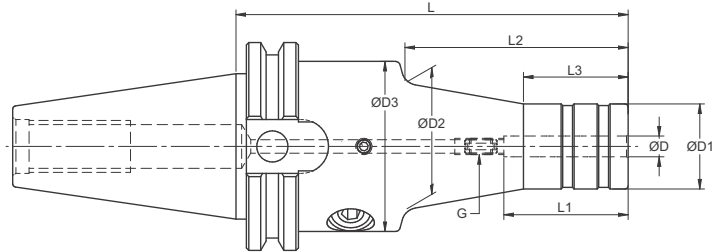

FEATURES

- Balanced to G2.5 @ 25,000 RPM
- T.I.R. < 0.0002"
- Taper shank ground to AT3 accuracy (or better)
- Bore tolerance: H6

Catalog Number	Description	ØD (inch)	ØD1 (inch)	ØD2 (inch)	ØD3 (inch)	L (inch)	L1 (inch)	L2 (inch)	L3 (inch)	G (inch)	Coolant Style
681381124SL	CATP50-HCSL 0.250-4.72	0.250	1.03	1.53	2.50	4.72	1.50	2.68	1.26	M5x0.8	AD Thru
681381324SL	CATP50-HCSL 0.312-4.72	0.312	1.10	1.61	2.50	4.72	1.65	2.68	1.26	M5x0.8	AD Thru
681382624SL	CATP50-HCSL 0.375-4.72	0.375	1.18	1.69	2.50	4.72	1.77	2.68	1.26	M6x1	AD Thru
681381524SL	CATP50 HCSL 0.500-4.72	0.500	1.26	1.77	2.50	4.72	1.81	2.68	1.26	M8x1	AD Thru

AccuClamp™ Torque wrenches [on page 204](#)
 AccuClamp™ Reduction Sleeves [on page 191-192](#)
 Retention knobs [on page 198-199](#)

CATP50 Face Contact AccuClamp™ Heavy Duty Hydraulic Chucks

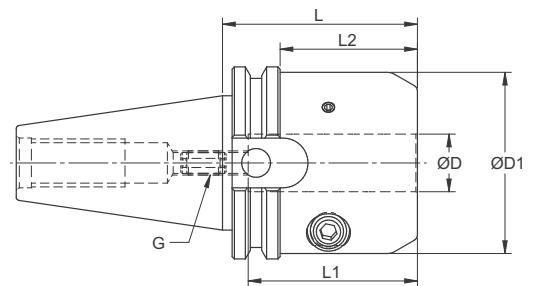

FEATURES

- Balanced to G2.5 @ 25,000 RPM
- T.I.R. < 0.0002"
- Taper shank ground to AT3 accuracy (or better)
- Bore tolerance: H6

Catalog Number	Description	ØD	ØD1	L	L1	L2	G	Coolant Style
671382817	CATP50-HC 0.750-3.25	0.75	2.36	3.25	2.05	2.50	M8x1	AD Thru
671382217	CATP50-HC 1.250-3.25	1.25	2.84	3.25	2.44	2.50	M8x1	AD Thru

AccuClamp™ Torque wrenches [on page 204](#)
 AccuClamp™ Reduction Sleeves [on page 191-192](#)
 Retention knobs [on page 198-199](#)

BT Holders

BT End Mill Holders (MAS403)

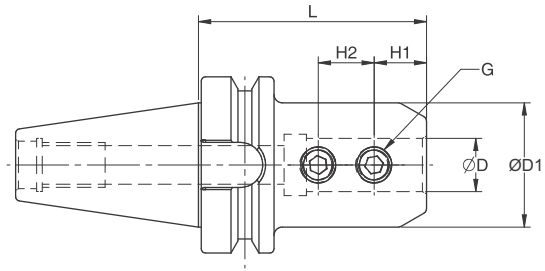

FEATURES

- Balanced to G2.5 @ 25,000 RPM
- Taper shank ground to AT3 accuracy (or better)
- T.I.R. < 0.0004"
- Bore tolerance: H6

	Catalog Number	Description	ØD	L	ØD1	G	H1	H2	Coolant Style
BT30 Inch	84100712	BT30-EMH 0.125-2.36	0.125	2.36	0.50	#10-32	0.21	-	AD Thru
	84100912	BT30-EMH 0.187-2.36	0.187	2.36	0.69	#10-32	0.56	-	AD Thru
	84101112	BT30-EMH 0.250-2.36	0.250	2.36	0.69	1/4"-28	0.56	-	AD Thru
	84102612	BT30-EMH 0.375-2.36	0.375	2.36	1.00	3/8"-24	0.75	-	AD Thru
	84101512	BT30-EMH 0.500-2.36	0.500	2.36	1.25	7/16"-20	0.88	-	AD Thru
	84101712	BT30-EMH 0.625-2.36	0.625	2.36	1.62	9/16"-18	0.94	-	AD Thru
	84102812	BT30-EMH 0.750-2.36	0.750	2.36	1.75	5/8"-18	1.00	-	AD Thru
	84102115	BT30-EMH 1.000-3.00	1.000	3.00	2.25	3/4"-16	1.00	-	AD Thru
84102215	BT30-EMH 1.250-3.00	1.250	3.00	2.25	3/4"-16	1.00	-	AD Thru	
BT30 Metric (DIN-1835-B)	84100612	BT30-EMH 6-60	6	60	25	M6	18.0	-	AD Thru
	84100812	BT30-EMH 8-60	8	60	28	M8	18.0	-	AD Thru
	84101012	BT30-EMH 10-60	10	60	35	M10	20.0	-	AD Thru
	84101212	BT30-EMH 12-60	12	60	42	M12	22.5	-	AD Thru
	84101612	BT30-EMH 16-60	16	60	48	M14	24.0	-	AD Thru
	84102012	BT30-EMH 20-60	20	60	52	M16	25.0	-	AD Thru
BT40 Inch	84120713	BT40-EMH 0.125-2.55	0.125	2.55	0.50	#10-32	0.21	-	AD Thru
	84120913	BT40-EMH 0.187-2.55	0.187	2.55	0.69	#10-32	0.56	-	AD Thru
	84120920	BT40-EMH 0.187-4.00	0.187	4.00	0.69	#10-32	0.56	-	AD Thru
	84121113	BT40-EMH 0.250-2.55	0.250	2.55	0.69	1/4"-28	0.56	-	AD Thru
	84121120	BT40-EMH 0.250-4.00	0.250	4.00	0.69	1/4"-28	0.56	-	AD Thru
	84121313	BT40-EMH 0.312-2.55	0.312	2.55	1.00	1/4"-28	0.75	-	AD Thru
	84121320	BT40-EMH 0.312-4.00	0.312	4.00	1.00	1/4"-28	0.75	-	AD Thru
	84122613	BT40-EMH 0.375-2.55	0.375	2.55	1.00	3/8"-24	0.75	-	AD Thru
	84122620	BT40-EMH 0.375-4.00	0.375	4.00	1.00	3/8"-24	0.75	-	AD Thru
	84121513	BT40-EMH 0.500-2.55	0.500	2.55	1.25	7/16"-20	0.88	-	AD Thru
	84121520	BT40-EMH 0.500-4.00	0.500	4.00	1.25	7/16"-20	0.88	-	AD Thru
	84121713	BT40-EMH 0.625-2.55	0.625	2.55	1.50	9/16"-18	0.94	-	AD Thru
	84121720	BT40-EMH 0.625-4.00	0.625	4.00	1.50	9/16"-18	0.94	-	AD Thru
	84122813	BT40-EMH 0.750-2.55	0.750	2.55	1.75	5/8"-18	1.00	-	AD Thru
	84121917	BT40-EMH 0.875-3.35	0.875	3.35	1.75	5/8"-18	1.00	0.81	AD Thru
	84122119	BT40-EMH 1.000-3.74	1.000	3.74	2.25	3/4"-16	1.13	1.00	AD Thru
	84122125	BT40-EMH 1.000-5.00	1.000	5.00	2.25	3/4"-16	1.13	1.00	AD Thru
	84122218	BT40-EMH 1.250-3.50	1.250	3.50	2.25	3/4"-16	1.00	1.00	AD Thru
	84122220	BT40-EMH 1.250-4.00	1.250	4.00	2.36	3/4"-16	1.13	1.00	AD Thru
	84122322	BT40-EMH 1.500-4.25	1.500	4.25	2.75	3/4"-16	1.12	1.00	AD Thru
BT40 Metric (DIN-1835-B)	84120615	BT40-EMH 6-75	6	75	25	M6	18.0	-	AD Thru
	84120815	BT40-EMH 8-75	8	75	28	M8	18.0	-	AD Thru
	84121015	BT40-EMH 10-75	10	75	35	M10	20.0	-	AD Thru
	84121215	BT40-EMH 12-75	12	75	42	M12	22.5	-	AD Thru
	84121615	BT40-EMH 16-75	16	75	48	M14	24.0	-	AD Thru
	84122015	BT40-EMH 20-75	20	75	52	M16	25.0	-	AD Thru
	84122518	BT40-EMH 25-90	25	90	65	M18	24.0	25	AD Thru
	84123224	BT40-EMH 32-120	32	120	72	M20	24.0	28	AD Thru
	84124024	BT40-EMH 40-120	40	120	90	M20	30.0	32	AD Thru

BT Holders

BT ER Collet Chucks (MAS 403)

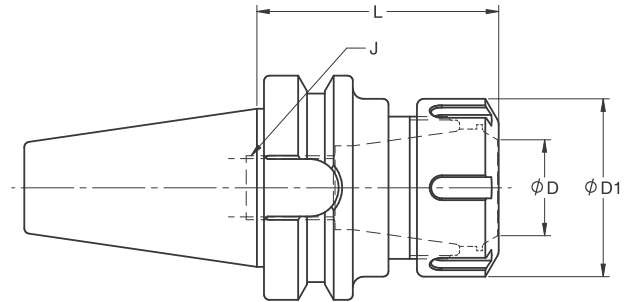

FEATURES

- Balanced to G2.5 @ 25,000 RPM
- T.I.R. < 0.0002
- Taper shank ground to AT3 accuracy (or better)
- Balanced ER Collet Nuts

	Catalog Number	Description	Collet Size	ϕD Range (mm)	$\phi D1$ (mm)	L (mm)	J	Coolant Style
BT30	87210014	BT30-CHE 11-70	ER11	3 - 7	19	70	M8x1.25	AD Thru
	87210020	BT30-CHE 11-100	ER11	3 - 7	19	100	M8x1.25	AD Thru
	87210024	BT30-CHE 11-120	ER11	3 - 7	19	120	M8x1.25	AD Thru
	87210114	BT30-CHE 16-70	ER16	3 - 10	28	70	M10X1.5	AD Thru
	87210120	BT30-CHE 16-100	ER16	3 - 10	28	100	M10X1.5	AD Thru
	87210124	BT30-CHE 16-120	ER16	3 - 10	28	120	M10X1.5	AD Thru
	87210214	BT30-CHE 20-70	ER20	3 - 13	34	70	M12X1.75	AD Thru
	87210220	BT30-CHE 20-100	ER20	3 - 13	34	100	M12X1.75	AD Thru
	87210227	BT30-CHE 20-135	ER20	3 - 13	34	135	M12X1.75	AD Thru
	87210312	BT30-CHE 25-60	ER25	3 - 16	42	60	M16X2	AD THRU
	87210314	BT30-CHE 25-70	ER25	3 - 16	42	70	M16X2.0	AD Thru
	87210320	BT30-CHE 25-100	ER25	3 - 16	42	100	M16X2.0	AD Thru
	87210327	BT30-CHE 25-135	ER25	3 - 16	42	135	M16X2.0	AD Thru
	87210414	BT30-CHE 32-70	ER32	3 - 20	50	70	M18X1.5	AD Thru
BT40	87212014	BT40-CHE 11-70	ER11	3 - 7	19	70	M8x1.25	AD Thru
	87212020	BT40-CHE 11-100	ER11	3 - 7	19	100	M8x1.25	AD Thru
	87212026	BT40-CHE 11-130	ER11	3 - 7	19	130	M8x1.25	AD Thru
	87212114	BT40-CHE 16-70	ER16	3 - 10	28	70	M10X1.5	AD Thru
	87212120	BT40-CHE 16-100	ER16	3 - 10	28	100	M10X1.5	AD Thru
	87212126	BT40-CHE 16-130	ER16	3 - 10	28	130	M10X1.5	AD Thru
	87212214	BT40-CHE 20-70	ER20	3 - 13	34	70	M12X1.75	AD Thru
	87212220	BT40-CHE 20-100	ER20	3 - 13	34	100	M12X1.75	AD Thru
	87212230	BT40-CHE 20-150	ER20	3 - 13	34	150	M16X2.0	AD Thru
	87212314	BT40-CHE 25-70	ER25	3 - 16	42	70	M16X2.0	AD Thru
	87212320	BT40-CHE 25-100	ER25	3 - 16	42	100	M16X2.0	AD Thru
	87212330	BT40-CHE 25-150	ER25	3 - 16	42	150	M16X2.0	AD Thru
	87212414	BT40-CHE 32-70	ER32	3 - 20	50	70	M18X1.5	AD Thru
	87212420	BT40-CHE 32-100	ER32	3 - 20	50	100	M18X1.5	AD Thru
	87212430	BT40-CHE 32-150	ER32	3 - 20	50	150	M18X1.5	AD Thru
	87212516	BT40-CHE 40-80	ER40	4 - 26	63	80	M22X1.5	AD Thru
	87212524	BT40-CHE 40-120	ER40	4 - 26	63	120	M22X1.5	AD Thru

ER Collets on page 182-186
 ER Nut Wrenches on page 203
 Retention knobs on page 191-192

BT Holders

BT Shell Mill Holder (MAS 403)

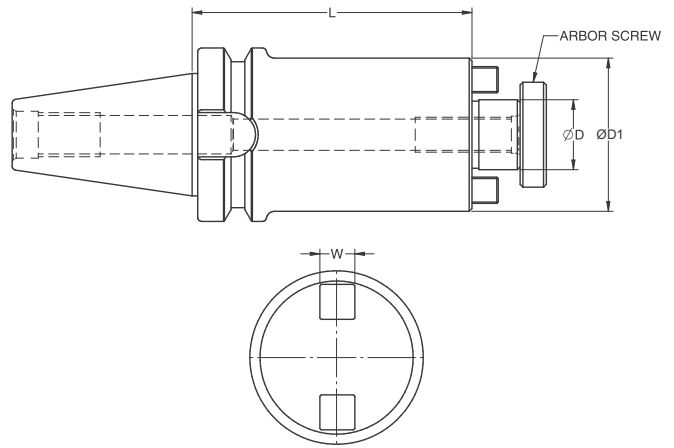

FEATURES

- Balanced to G2.5 @ 25,000 RPM
- T.I.R. < 0.0004"
- Taper shank ground to AT3 accuracy (or better)
- Coolant through the center of the body

	Catalog Number	Description	ØD	L	ØD1	H	W	Coolant Style	Ret. Screw
BT30 Inch	81105006	BT30-SMH 0.500-1.13	0.500	1.13	1.34	0.56	0.250	AD THRU	1/4-28
	81107506	BT30-SMH 0.750-1.18	0.750	1.18	1.94	0.69	0.312	AD THRU	3/8-24
	81101009	BT30-SMH 1.000-1.77	1.000	1.77	2.19	0.69	0.375	AD THRU	1/2-20
BT30 Metric	81101606	BT30-SMH 16-30	16	30	34	15	8	AD THRU	M8X25*
	81102209	BT30-SMH 22-45	22	45	45	18	10	AD THRU	M10X30*
BT40 Inch	81125009	BT40-SMH 0.500-1.77	0.500	1.77	1.75	0.56	0.250	AD THRU	1/4-28
	81125020	BT40-SMH 0.500-4.00	0.500	4.00	1.75	0.56	0.250	AD THRU	1/4-28
	81127509	BT40-SMH 0.750-1.77	0.750	1.77	1.75	0.69	0.312	AD THRU	3/8-24
	81127520	BT40-SMH 0.750-4.00	0.750	4.00	1.75	0.69	0.312	AD THRU	3/8-24
	81127530	BT40-SMH 0.750-6.00	0.750	1.77	1.75	0.69	0.312	AD THRU	3/8-24
	81121009	BT40-SMH 1.000-1.77	1.000	1.77	2.19	0.69	0.375	AD THRU	1/2-20
	81121020	BT40-SMH 1.000-4.00	1.000	4.00	2.19	0.69	0.375	AD THRU	1/2-20
	81121030	BT40-SMH 1.000-6.00	1.000	6.00	2.19	0.69	0.375	AD THRU	1/2-20
	81121212	BT40-SMH 1.250-2.36	1.250	2.36	2.75	0.69	0.500	AD THRU	5/8-18
	81121225	BT40-SMH 1.250-5.00	1.250	5.00	2.75	0.69	0.500	AD THRU	5/8-18
	80121512	BT40-SMH 1.500-2.36	1.500	2.36	3.38	0.94	0.625	AD THRU	3/4-16
80121525	BT40-SMH 1.500-5.00	1.500	5.00	3.38	0.94	0.625	AD THRU	3/4-16	
BT40 Metric	81121612	BT40-SMH 16-60	16	60	34	15	8	AD THRU	M8X25*
	81122209	BT40-SMH 22-45	22	45	45	18	10	AD THRU	M10X30*
	81122218	BT40-SMH 22-90	22	60	45	18	10	AD THRU	M10X30*
	81122712	BT40-SMH 27-60	27	60	70	20	12	AD THRU	M12X35*
	81122718	BT40-SMH 27-90	27	90	70	20	12	AD THRU	M12X35*
	81123212	BT40-SMH 32-60	32	60	85	22	14	AD THRU	M16X35*
	81123215	BT40-SMH 32-75	32	75	85	22	14	AD THRU	M16X35*

NOTE:

ALL Shell Mill Holders are supplied with coolant through the center up to the arbor screw hole.

Represents Holders provided with metric allen cap bolt.

*Retention knobs **on page 198-199**

Non-Coolant and Coolant Arbor Screws **on page 202**

BT Holders

BT AccuMill™ Milling Chuck (MAS 403)

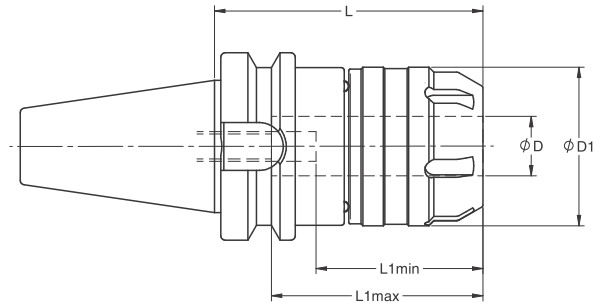

FEATURES

- Balanced to G2.5 @ 25,000 RPM
- T.I.R. < 0.0002"
- Taper shank ground to AT3 accuracy (or better)
- Bore tolerance: H6

	Catalog Number	Description	Collet Size	Collet Capacity Range	ϕD	$\phi D1$	L	L1 Min/Max	Coolant Style
BT30 Inch	97102816	BT30-MMC 0.750-3.15	0.750	.125 - .625	0.750	2.09	3.15	2.50/2.75	AD Thru
BT40 Inch	97122816	BT40-MMC 0.750-3.15	0.750	.125 - .625	0.750	2.09	3.15	2.50/2.75	AD Thru
	97122824	BT40-MMC 0.750-4.72	0.750	.125 - .625	0.750	2.09	4.72	2.50/2.75	AD Thru
	97122218	BT40-MMC 1.250-3.54	1.250	.125 - 1.00	1.000	2.64	3.54	3.09/3.34	AD Thru
	97122224	BT40-MMC 1.250-4.72	1.250	.125 - 1.00	1.000	2.64	4.72	3.09/3.34	AD Thru
BT40 Metric	97122016	BT40-MMC 20-80	20	3 - 16	20	53	80	63/70	AD Thru
	97122024	BT40-MMC 20-120	20	3 - 16	20	53	120	63/70	AD Thru
	97123218	BT40-MMC 32-90	32	3 - 25	32	67	90	78/85	AD Thru
	97123224	BT40-MMC 32-120	32	3 - 25	32	67	120	78/85	AD Thru

AccuMill™ Collets on page 191-192
 AccuMill™ Collet Nut wrenches on page 201
 Retention knobs on page 198-199

BT AccuClamp™ Hydraulic Chuck (MAS 403)

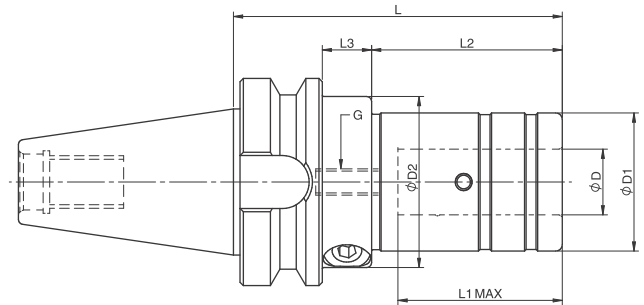

FEATURES

- Balanced to G2.5 @ 25,000 RPM
- T.I.R. < 0.0002
- Taper shank ground to AT3 accuracy (or better)
- Bore tolerance: H6

	Catalog Number	Description	ϕD	$\phi D1$	$\phi D2$	L	L1 MAX	L2	L3	G	Coolant Style
BT30 Metric	68102020	BT30-HCS 20-100	20	42	52	100	52	53.8	19.05	M8X1	AD Thru
BT40 Metric	68122020	BT40-HCS 20-100	20	42	52	100	52	55.9	17.00	M8X1	AD Thru
	68123223	BT40-HCS 32-115	32	60	-	115	60	80.0	-	M8X1	AD Thru
BT30 inch	68102820	BT30-HCS 0.75-4.00	0.75	1.65	2.05	4.0	2.05	2.18	0.75	M8X1	AD Thru
BT40 Inch	68122820	BT40-HCS 0.75-4.00	0.75	1.65	2.05	4.0	2.05	2.20	0.67	M8X1	AD Thru
	68122223	BT40-HCS 1.25-4.52	1.25	2.36	-	4.52	2.44	3.50	-	M8X1	AD Thru

AccuClamp™ Torque wrenches on page 204
 AccuClamp™ Reduction Sleeves on page 191-192
 Retention knobs on page 198-199

BT Holders

BT30 AccuClamp™ Hydraulic Chucks Slim Design (MAS 403)

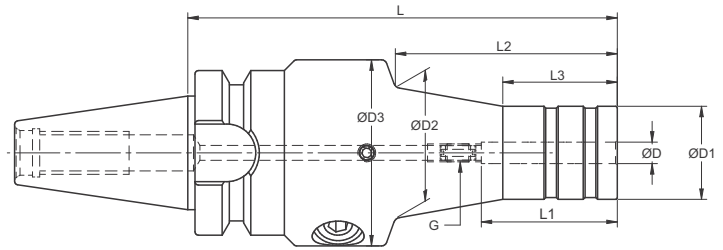

FEATURES

- Balanced to G2.5 @ 25,000 RPM
- Taper shank ground to AT3 accuracy (or better)
- T.I.R. < 0.0002"
- Bore tolerance: H6

Catalog Number	Description	ØD (inch)	ØD1 (inch)	ØD2 (inch)	ØD3 (inch)	L (inch)	L1 (inch)	L2 (inch)	L3 (inch)	G (inch)	Coolant Style
68100624SL	BT30-HCSL 6-120	6.000	26	36.60	52	120	38	62	32	M5x0.8	AD Thru
68100824SL	BT30-HCSL 8-120	8.000	28	38.60	52	120	42	62	32	M5x0.8	AD Thru
68101024SL	BT30-HCSL 10-120	10.000	30	40.60	52	120	45	62	32	M6x1	AD Thru
68101224SL	BT30-HCSL 12-120	12.000	32	42.60	52	120	46	62	32	M8x1	AD Thru

AccuClamp™ Torque wrenches **on page 204**

AccuClamp™ Reduction Sleeves **on page 191-192**

Retention knobs **on page 198-199**

Notes:

Did you know?

In the U.S., for every \$1.00 spent in manufacturing, another \$1.89 is added to the economy. That is the highest multiplier effect of any economic sector.

nam.org

BTP AccuPlus™ Face Contact Holders

BTP30 Face Contact End Mill Holder

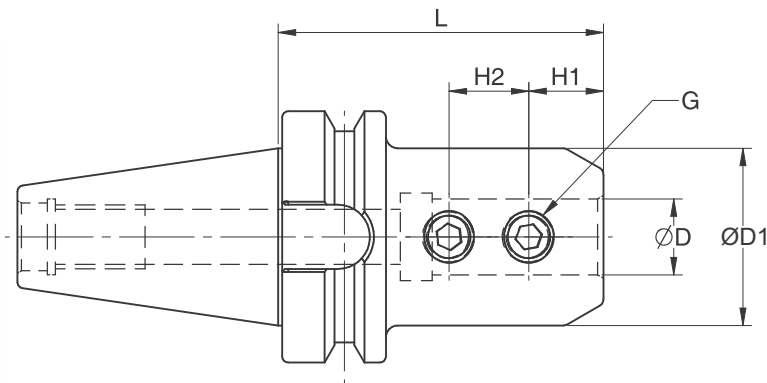

FEATURES

- Balanced to G2.5 @ 25,000 RPM
- Bore Tolerance: H6
- T.I.R. < 0.0004"
- Taper shank ground to AT3 accuracy (or better)

	Catalog Number	Description	ØD	ØD1	L	G	H1	H2	Coolant Style
BTP30 Inch	841060713	BTP30-EMH 0.125-2.50	0.125	0.50	2.50	10-32	0.21	-	AD Thru
	841060913	BTP30-EMH 0.187-2.50	0.187	0.69	2.50	10-32	0.56	-	AD Thru
	841061113	BTP30-EMH 0.250-2.50	0.250	0.69	2.50	1/4"-28	0.56	-	AD Thru
	841062613	BTP30-EMH 0.375-2.50	0.375	1.00	2.50	3/8"-24	0.75	-	AD Thru
	841061513	BTP30-EMH 0.500-2.50	0.500	1.75	2.50	7/16"-20	0.88	-	AD Thru
	841061713	BTP30-EMH 0.625-2.50	0.625	1.75	2.50	9/16"-18	0.94	-	AD Thru
	841062816	BTP30-EMH 0.750-3.00	0.750	1.75	3.00	5/8"-18	1.00	-	AD Thru
BTP30 Metric	841060612	BTP30-EMH 6-60	6	25	60	M6	18	-	AD Thru
	841060812	BTP30-EMH 8-60	8	28	60	M8	18	-	AD Thru
	841061012	BTP30-EMH 10-60	10	35	60	M10	20	-	AD Thru
	841061212	BTP30-EMH 12-60	12	42	60	M12	22.5	-	AD Thru
	841061612	BTP30-EMH 16-60	16	48	60	M14	24	-	AD Thru
	841062012	BTP30-EMH 20-60	20	52	60	M16	25	-	AD Thru
BTP40 Inch	841081113	BTP40-EMH 0.250-2.50	0.250	0.690	2.50	1/4"-28	0.560	-	AD Thru
	841081313	BTP40-EMH 0.312-2.50	0.312	1.000	2.50	1/4"-28	0.750	-	AD Thru
	841082613	BTP40-EMH 0.375-2.55	0.375	1.000	2.55	3/8"-24	0.750	-	AD Thru
	841081516	BTP40-EMH 0.500-3.00	0.500	1.250	3.00	7/16"-20	0.750	-	AD Thru
	841081716	BTP40-EMH 0.625-3.00	0.625	1.500	3.00	9/16"-18	0.940	-	AD Thru
	841082821	BTP40-EMH 0.750-4.00	0.750	1.750	4.00	5/8"-18	1.000	-	AD Thru
	841082121	BTP40-EMH 1.000-4.00	1.000	2.250	4.00	3/4"-16	1.130	1.00	AD Thru
	841082221	BTP40-EMH 1.250-4.00	1.250	2.250	4.00	3/4"-16	1.000	1.00	AD Thru
BTP40 Metric	841081618	BTP40-EMH 16-90	16	48	90	M14	24	-	AD Thru
	841082018	BTP40-EMH 20-90	20	52	90	M16	25	-	AD Thru
	841082518	BTP40-EMH 25-90	25	65	90	M18	24	22	AD Thru
	841083218	BTP40-EMH 32-90	32	72	90	M20	24	24	AD Thru
	841084018	BTP40-EMH 40-90	40	90	90	M20	30	22	AD Thru

Retention knobs on page 198-199

BTP AccuPlus™ Face Contact Holders

BTP Face Contact ER Collet Chuck

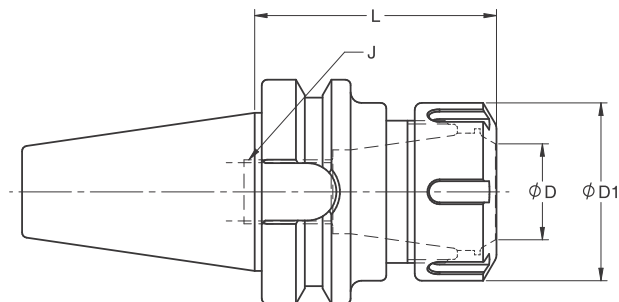

FEATURES

- Balanced to G2.5 @ 25,000 RPM
- Taper shank ground to AT3 accuracy (or better)
- T.I.R. < 0.0002"
- Balanced ER Collet Nuts

	Catalog Number	Description	Collet Size	ϕD Range (mm)	$\phi D1$ (mm)	L (mm)	J Adj. Screw	Coolant Style
BTP30	872106020	BTP30-CHE 11-100	ER11	3 - 7	19	100	M6X1	AD Thru
	872106112	BTP30-CHE 16-60	ER16	3 - 10	28	60	M10X1.5	AD Thru
	872106120	BTP30-CHE 16-100	ER16	3 - 10	28	100	M10X1.5	AD Thru
	872106212	BTP30-CHE 20-60	ER20	3 - 13	34	60	M12X1.75	AD Thru
	872106221	BTP30-CHE 20-105	ER20	3 - 13	34	105	M12X1.75	AD Thru
	872106312	BTP30-CHE 25-60	ER25	3 - 16	42	60	M16X2.0	AD Thru
	872106320	BTP30-CHE 25-100	ER25	3-16	42	100	M16X2.0	AD Thru
	872106412	BTP30-CHE 32-60	ER32	3 - 20	50	60	M18X1.5	AD Thru
	872106420	BTP30-CHE 32-100	ER32	3 - 20	50	100	M18X1.5	AD Thru
BTP40	872108020	BTP40-CHE 11-100	ER11	3 - 7	19	100	M6X1	AD Thru
	872108114	BTP40-CHE 16-70	ER16	3 - 10	28	70	M10X1.5	AD Thru
	872108120	BTP40-CHE 16-100	ER16	3 - 10	28	100	M10X1.5	AD Thru
	872108120	BTP40-CHE 16-135	ER16	3 - 10	28	135	M10X1.5	AD Thru
	872108133	BTP40-CHE 16-165	ER16	3 - 10	28	165	M10X1.5	AD Thru
	872108214	BTP40-CHE 20-70	ER20	3 - 13	34	70	M12X1.75	AD Thru
	872108224	BTP40-CHE 20-120	ER20	3 - 13	34	120	M12X1.75	AD Thru
	872108314	BTP40-CHE 25-70	ER25	3 - 16	42	70	M16X2.0	AD Thru
	872108324	BTP40-CHE 25-120	ER25	3 - 16	42	120	M16X2.0	AD Thru
	872108414	BTP40-CHE 32-70	ER32	3 - 20	50	70	M18X1.5	AD Thru
	872108424	BTP40-CHE 32-120	ER32	3 - 20	50	120	M18X1.5	AD Thru
	872108516	BTP40-CHE 40-80	ER40	4 - 26	63	80	M22X1.5	AD Thru
	872108520	BTP40-CHE 40-100	ER40	4 - 26	63	100	M22X1.5	AD Thru
	872108524	BTP40-CHE 40-120	ER40	4 - 26	63	120	M22X1.5	AD Thru

ER Collets on page 182-186
 ER Nut Wrenches on page 203
 Retention knobs on page 198-199

BTP AccuPlus™ Face Contact Holders

BTP Face Contact Shell Mill Holders

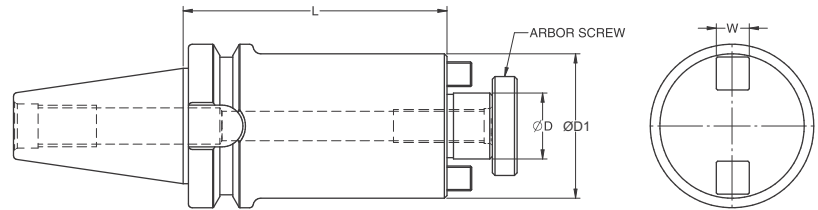

FIG.1

FEATURES

- Balanced to G2.5 @ 25,000 RPM
- AD coolant thru the spindle with coolant through the center of the body
- < 0.0002"
- Taper shank ground to AT3 accuracy (or better)

	Catalog Number	Description	ØD	L	ØD1	H	W	Coolant Style	Ret. Screw
BTP30 Inch	811065011	BTP30-SMH 0.500-2.00	0.500	2.00	1.34	0.56	0.250	AD Thru	1/4-28
	811067511	BTP30-SMH 0.750-2.00	0.750	2.00	1.94	0.69	0.312	AD Thru	3/8-24
	811061011	BTP30-SMH 1.000-2.00	1.000	2.00	2.19	0.69	0.375	AD Thru	1/2-20
	811061606	BTP30-SMH 16-30	16	30	34	15	8	AD Thru	M8X1.25
	811062209	BTP30-SMH 22-45	22	45	45	18	10	AD Thru	M10X30
BTP40 Inch	811085011	BTP40-SMH 0.500-2.00	0.500	2.00	1.34	0.56	0.250	AD Thru	1/4-28
	811085021	BTP40-SMH 0.500-4.00	0.500	4.00	1.34	0.56	0.250	AD Thru	1/4-28
	811087511	BTP40-SMH 0.750-2.00	0.750	2.00	1.94	0.69	0.312	AD Thru	3/8-24
	811087521	BTP40-SMH 0.750-4.00	0.750	4.00	1.94	0.69	0.312	AD Thru	3/8-24
	811081011	BTP40-SMH 1.000-2.00	1.000	2.00	2.19	0.69	0.375	AD Thru	1/2-20
	811081021	BTP40-SMH 1.000-4.00	1.000	4.00	2.19	0.69	0.375	AD Thru	1/2-20
	811081211	BTP40-SMH 1.250-2.00	1.250	2.00	2.75	0.69	0.500	AD Thru	5/8-18
	811081226	BTP40-SMH 1.250-5.00	1.250	5.00	2.75	0.69	0.500	AD Thru	5/8-18
	811081511	BTP40-SMH 1.500-2.00	1.500	2.00	3.38	0.94	0.625	AD Thru	3/4-16
811081526	BTP40-SMH 1.500-5.00	1.500	5.00	3.38	0.94	0.625	AD Thru	3/4-16	
BTP40 Metric	811081612	BTP40-SMH 16-60	16	60	34	15	8	AD Thru	M8X1.25
	811082209	BTP40-SMH 22-45	22	45	45	18	10	AD Thru	M10X30
	811082218	BTP40-SMH 22-90	22	60	45	18	10	AD Thru	M10X30
	811082712	BTP40-SMH 27-60	27	60	70	20	12	AD Thru	M12X35
	811082718	BTP40-SMH 27-90	27	90	70	20	12	AD Thru	M12X35
	811083212	BTP40-SMH 32-60	32	60	85	22	14	AD Thru	M16X35
	811083215	BTP40-SMH 32-75	32	75	85	22	14	AD Thru	M16X35

NOTE:

ALL Shell Mill Holders are supplied with coolant through the center up to the arbor screw hole.

Retention knobs **on page 198-199**

Non-Coolant and Coolant Arbor Screws **on page 202**

BTP AccuPlus™ Face Contact Holders

BTP Face Contact AccuMill™ Multi-Milling Chucks

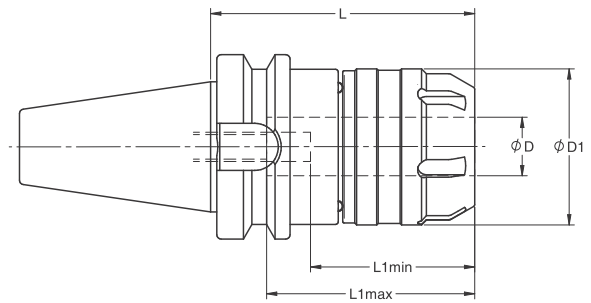

FEATURES

- Balanced to G2.5 @ 25,000 RPM
- T.I.R. < 0.0002"
- Taper shank ground to AT3 accuracy (or better)

	Catalog Number	Description	Collet Size	Capacity Range	ØD	ØD1	L	L1 Min.	L1 Max.	Coolant Style
BTP30 Inch	971062816	BTP30-MMC 0.750-3.15	0.750	.125-.625	0.750	2.09	3.15	2.50	2.75	AD Thru

	Catalog Number	Description	Collet Size	Capacity Range	ØD	ØD1	L	L1 Min.	L1 Max.	Coolant Style
BTP40 Inch	971082816	BTP40-MMC 0.750-3.15	0.750	.125-.625	0.750	2.09	3.15	2.50	2.75	AD Thru
	971082824	BTP40-MMC 0.750-4.72	0.750	.125-.625	0.750	2.09	4.72	2.50	2.75	AD Thru
	971082218	BTP40-MMC 1.250-3.54	1.250	.125-1.000	1.000	2.64	3.54	3.09	3.34	AD Thru
	971082224	BTP40-MMC 1.250-4.72	1.250	.125-1.000	1.000	2.64	4.72	3.09	3.34	AD Thru
BTP40 Metric	971082016	BTP40 -MMC- 20-80	20	3--16	20	53	80	63	70	AD Thru
	971082024	BTP40 -MMC- 20-120	20	3--16	20	53	120	63	70	AD Thru
	971083218	BTP40 -MMC- 32-90	32	3--25	32	67	90	78	85	AD Thru
	971083224	BTP40 -MMC- 32-120	32	3--25	32	67	120	78	85	AD Thru

AccuMill™ Collets on page 191-192
 AccuMill™ Collet Nut wrenches on page 201
 Retention knobs on page 198-199

BTP Face Contact AccuClamp™ Hydraulic Chuck

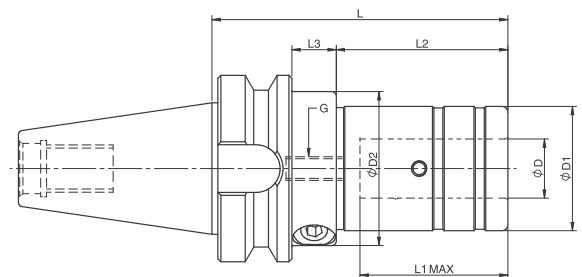

FEATURES

- Balanced to G2.5 @ 25,000 RPM
- T.I.R. < 0.0002
- Taper shank ground to AT3 accuracy (or better)
- Bore tolerance: H6

	Catalog Number	Description	ØD	ØD1	ØD2	L	L1 MAX	L2	L3	G	Coolant Style
BTP30 Metric	681062020	BTP30-HCS 20-100	20	1.65	2.05	100	2.05	2.16	0.75	M8X1	AD Thru
BTP40 Metric	681082020	BTP40-HCS 20-100	20	1.65	2.05	100	2.05	2.20	0.67	M8X1	AD Thru
	681083223	BTP40-HCS 32-115	32	2.36	-	115	2.44	3.46	-	M8X1	AD Thru
BTP30 inch	681062820	BTP30-HCS 0.75-4.00	0.75	1.65	2.05	4.0	2.05	2.22	0.75	M8X1	AD Thru
BTP40 Inch	681082820	BTP40-HCS 0.75-4.00	0.75	1.65	2.05	4.0	2.05	2.20	0.67	M8X1	AD Thru
	681082223	BTP40-HCS 1.25-4.52	1.25	2.36	-	4.52	2.44	3.50	-	M8X1	AD Thru

AccuClamp™ Torque wrenches on page 204
 AccuClamp™ Reduction Sleeves on page 191-192
 Retention knobs on page 198-199

HSK Holders

HSK End Mill Holder (DIN 6499 AND DIN 1835/B) - Inch ID



MODEL:-SL/HSK
(DIN-69893 A+C
(THRU. COOLANT))

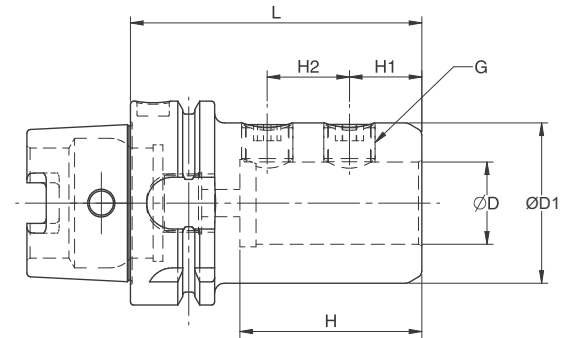

FEATURES

- Balanced to G2.5 @ 25,000 RPM
- T.I.R. < 0.0004"

- Bore tolerance: H6

	Catalog Number	Description	ØD (inch)	L (inch)	ØD1 (inch)	H (inch)	H1 (inch)	H2 (inch)	G (inch)	Coolant Style
HSK32A Inch ID	8471A1112	HSK32A-EMH 0.250-2.36	0.250	2.36	0.690	0.870	0.56	-	1/4"-28	AD Thru
	8471A1312	HSK32A-EMH 0.312-2.36	0.312	2.36	1.00	1.06	0.75	-	1/4"-28	AD Thru
	8471A2613	HSK32A-EMH 0.375-2.56	0.375	2.56	1.250	1.490	0.75	-	3/8"-24	AD Thru
	8471A1515	HSK32A-EMH 0.500-2.95	0.500	2.95	1.250	1.730	0.75	-	7/16"-20	AD Thru
	8471A1715	HSK32A-EMH 0.625-2.95	0.625	2.95	1.750	1.890	0.94	-	9/16"-18	AD Thru
HSK40A Inch ID	8472A0712	HSK40A-EMH 0.125-2.36	0.125	2.36	0.500	0.87	0.56	-	#10-32	AD Thru
	8472A1112	HSK40A-EMH 0.250-2.36	0.250	2.36	0.690	0.870	0.56	-	1/4"-28	AD Thru
	8472A1312	HSK40A-EMH 0.312-2.36	0.312	2.36	1.000	1.060	0.75	-	1/4"-28	AD Thru
	8472A2613	HSK40A-EMH 0.375-2.56	0.375	2.56	1.250	1.490	0.75	-	3/8"-24	AD Thru
	8472A1514	HSK40A-EMH 0.500-2.76	0.500	2.76	1.250	1.730	0.75	-	7/16"-20	AD Thru
	8472A1716	HSK40A-EMH 0.625-3.15	0.625	3.15	1.750	1.890	0.94	-	9/16"-18	AD Thru
	8472A2816	HSK40A-EMH 0.750-3.15	0.750	3.15	1.750	2.010	1.00	-	5/8"-18	AD Thru
HSK50A Inch ID	8473A1113	HSK50A-EMH 0.250-2.56	0.250	2.56	0.690	0.870	0.56	-	1/4"-28	AD Thru
	8473A1313	HSK50A-EMH 0.312-2.56	0.312	2.56	1.000	1.060	0.75	-	1/4"-28	AD Thru
	8473A2613	HSK50A-EMH 0.375-2.56	0.375	2.56	1.250	1.490	0.75	-	3/8"-24	AD Thru
	8473A1516	HSK50A-EMH 0.500-3.15	0.500	3.15	1.250	1.730	0.75	-	7/16"-20	AD Thru
	8473A1716	HSK50A-EMH 0.625-3.15	0.625	3.15	1.750	1.890	0.94	-	9/16"-18	AD Thru
	8473A2816	HSK50A-EMH 0.750-3.15	0.750	3.15	1.750	2.010	1.00	-	5/8"-18	AD Thru
	8473A2121	HSK50A-EMH 1.000-4.13	1.000	4.13	2.000	3.000	1.12	1.00	3/4"-16	AD Thru
HSK63A Inch ID	8474A1113	HSK63A-EMH 0.250-2.56	0.250	2.56	0.690	0.870	0.56	-	1/4"-28	AD Thru
	8474A1313	HSK63A-EMH 0.312-2.56	0.312	2.56	1.000	1.060	0.75	-	1/4"-28	AD Thru
	8474A2613	HSK63A-EMH 0.375-2.56	0.375	2.56	1.000	1.490	0.75	-	3/8"-24	AD Thru
	8474A1516	HSK63A-EMH 0.500-3.15	0.500	3.15	1.750	1.730	0.75	-	7/16"-20	AD Thru
	8474A1716	HSK63A-EMH 0.625-3.15	0.625	3.15	1.620	1.890	0.94	-	9/16"-18	AD Thru
	8474A2816	HSK63A-EMH 0.750-3.15	0.750	3.15	1.750	2.010	1.00	-	5/8"-18	AD Thru
	8474A2122	HSK63A-EMH 1.000-4.33	1.000	4.33	1.950	3.000	1.12	1.00	3/4"-16	AD Thru
	8474A2223	HSK63A-EMH 1.250-4.33	1.250	4.33	2.500	3.000	1.12	1.00	3/4"-16	AD Thru
	8474A2322	HSK63A-EMH 1.500-4.33	1.500	4.33	2.75	3.15	1.12	1.00	3/4"-16	AD Thru
HSK100A Inch ID	8476A1118	HSK100A-EMH 0.250-3.54	0.250	3.54	0.690	0.870	0.56	-	1/4"-28	AD Thru
	8476A1318	HSK100A-EMH 0.312-3.54	0.312	3.54	1.000	1.060	0.75	-	1/4"-28	AD Thru
	8476A2618	HSK100A-EMH 0.375-3.54	0.375	3.54	1.000	1.490	0.75	-	3/8"-24	AD Thru
	8476A1520	HSK100A-EMH 0.500-3.94	0.500	3.94	1.380	1.730	0.75	-	7/16"-20	AD Thru
	8476A1720	HSK100A-EMH 0.625-3.94	0.625	3.94	1.620	1.890	0.94	-	9/16"-18	AD Thru
	8476A2822	HSK100A-EMH 0.750-4.33	0.750	4.33	1.750	2.010	1.00	-	5/8"-18	AD Thru
	8476A2124	HSK100A-EMH 1.000-4.72	1.000	4.72	2.250	3.000	1.12	1.00	3/4"-16	AD Thru
	8476A2224	HSK100A-EMH 1.250-4.72	1.250	4.72	2.500	3.000	1.12	1.00	3/4"-16	AD Thru
	8476A2324	HSK100A-EMH 1.500-4.72	1.500	4.72	2.750	3.150	1.12	1.00	3/4"-16	AD Thru

Coolant tubes on page 200

Coolant Tube Wrenches on page 204

HSK Holders

HSK End Mill Holder (DIN 6499 AND DIN 1835/B) – Metric ID

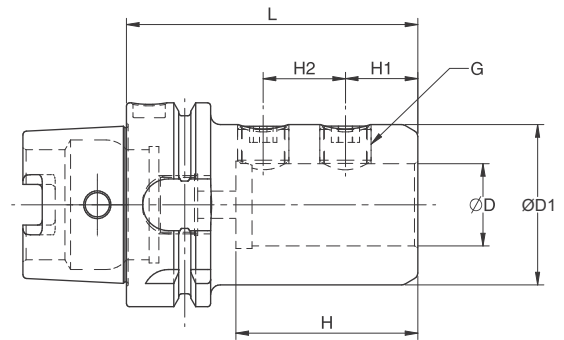

MODEL:-SL/HSK (DIN-69893 A+C)
(THRU. COOLANT)

FEATURES

- Balanced to G2.5 @ 25,000 RPM
- T.I.R. < 0.0004"
- Bore tolerance: H6

	Catalog Number	Description	ØD (mm)	L (mm)	C (mm)	H (mm)	H1 (mm)	H2 (mm)	G (mm)	Coolant Style
HSK63A Metric ID	8474A0613	HSK63A-EMH 6-65	6	65	25	36	18	-	M6	AD Thru
	8474A0813	HSK63A-EMH 8-65	8	65	28	36	18	-	M8	AD Thru
	8474A1013	HSK63A-EMH 10-65	10	65	35	40	20	-	M10	AD Thru
	8474A1216	HSK63A-EMH 12-80	12	80	42	45	22.50	-	M12	AD Thru
	8474A1416	HSK63A-EMH 14-80	14	80	44	45	22.50	-	M12	AD Thru
	8474A1616	HSK63A-EMH 16-80	16	80	48	48	24	-	M14	AD Thru
	8474A1816	HSK63A-EMH 18-80	18	80	50	48	24	-	M14	AD Thru
	8474A2016	HSK63A-EMH 20-80	20	80	52	50	25	-	M16	AD Thru
	8474A2522	HSK63A-EMH 25-110	25	110	65	56	24	25	M18	AD Thru
	8474A3222	HSK63A-EMH 32-110	32	110	72	60	24	28	M20	AD Thru
HSK100A Metric ID	8476A0618	HSK100A-EMH 6-90	6	90	25	36	18	-	M6	AD Thru
	8476A0818	HSK100A-EMH 8-90	8	90	28	36	18	-	M8	AD Thru
	8476A1018	HSK100A-EMH 10-90	10	90	35	40	20	-	M10	AD Thru
	8476A1220	HSK100A-EMH 12-100	12	100	42	45	22.50	-	M12	AD Thru
	8476A1420	HSK100A-EMH 14-100	14	100	44	45	22.50	-	M12	AD Thru
	8476A1620	HSK100A-EMH 16-100	16	100	48	48	24	-	M14	AD Thru
	8476A1820	HSK100A-EMH 18-100	18	100	50	48	24	-	M14	AD Thru
	8476A2022	HSK100A-EMH 20-110	20	110	52	50	25	-	M16	AD Thru
	8476A2524	HSK100A-EMH 25-120	25	120	65	56	24	25	M18	AD Thru
	8476A3224	HSK100A-EMH 32-120	32	120	72	60	24	28	M20	AD Thru
8476A4024	HSK100A-EMH 40-120	40	120	80	36	30	32	M20	AD Thru	

Coolant tubes [on page 200](#)
Coolant Tube Wrenches [on page 204](#)

HSK Holders

HSK-A ER Collet Chucks (DIN 69893 A+C)

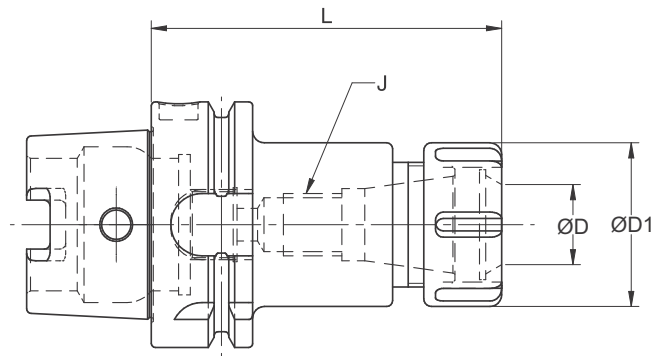

FEATURES

- Balanced to G2.5 @ 25,000 RPM
- T.I.R. < 0.0002"
- AD coolant thru the spindle
- Balanced ER Collet Nuts

	Catalog Number	Description	Collet Size	ØD Range (inch)	ØD1 (inch)	L (inch)	J Adj. Screw	Coolant Style
HSK32A	87271A113	HSK32A-CHE 16-2.56	ER16	.118 - .393	1.102	2.56	M10X1.5	AD Thru
	87271A216	HSK32A-CHE 20-3.15	ER20	.118 - .512	1.340	3.15	M12X1.75	AD Thru
	87271A314	HSK32A-CHE 25-2.76	ER25	.118 - .629	1.653	2.76	M16X2.0	AD Thru
HSK40A	87272A114	HSK40A-CHE 16-2.76	ER16	.118 - .393	1.102	2.76	M10X1.5	AD Thru
	87272A216	HSK40A-CHE 20-3.15	ER20	.118 - .512	1.340	3.15	M12X1.75	AD Thru
	87272A316	HSK40A-CHE 25-3.15	ER25	.118 - .629	1.653	3.15	M16X2	AD Thru
	87272A420	HSK40A-CHE 32-3.94	ER32	.118 - .787	1.968	3.94	M18X1.5	AD Thru
HSK50A	87273A116	HSK50A-CHE 16-3.15	ER16	.118 - .393	1.102	3.15	M10X1.5	AD Thru
	87273A216	HSK50A-CHE 16-3.15	ER20	.118 - .512	1.340	3.15	M12X1.75	AD Thru
	87273A319	HSK50A-CHE 25-3.74	ER25	.118 - .629	1.653	3.74	M16X2	AD Thru
	87273A420	HSK50A-CHE 32-3.94	ER32	.118 - .787	1.968	3.94	M18X1.5	AD Thru
HSK63A	87274A118	HSK63A-CHE 16-3.54	ER16	.118 - .393	1.102	3.15	M10X1.5	AD Thru
	87274A216	HSK63A-CHE 20-3.15	ER20	.118-.512	1.340	3.15	M12X1.75	AD Thru
	87274A232	HDK63A-CHE 20-6.30	ER20	.118-.512	1.340	6.30	M12X1.75	AD Thru
	87274A318	HSK63A-CHE 25-3.54	ER25	.118 - .629	1.653	3.74	M16X2	AD Thru
	87274A330	HSK63A-CHE 25-6.00	ER25	.118 - .629	1.653	6.00	M16X2	AD Thru
	87274A420	HSK63A-CHE 32-3.94	ER32	.118 - .787	1.968	3.94	M18X1.5	AD Thru
	87274A430	HSK63A-CHE 32-6.00	ER32	.118 - .787	1.968	6.00	M18X1.5	AD Thru
	87274A524	HSK63A-CHE 40-4.72	ER40	.157 - 1.023	2.480	4.72	M22X1.5	AD Thru
HSK100A	87276A220	HSK100A-CHE 20-3.94	ER20	.118 - .512	1.340	3.94	M12X1.75	AD Thru
	87276A232	HSK100A-CHE 20-6.30	ER20	.118 - .512	1.340	6.30	M12X1.75	AD Thru
	87276A320	HSK100A-CHE 25-3.94	ER25	.118 - .629	1.653	3.94	M16x2.00	AD Thru
	87276A330	HSK100A-CHE 25-6.30	ER25	.118 - .629	1.653	6.30	M16x2.00	AD Thru
	87276A420	HSK100A-CHE 32-3.94	ER32	.118 - .787	1.968	3.94	M18X1.5	AD Thru
	87276A430	HSK100A-CHE 32-6.00	ER32	.118 - .787	1.968	6.00	M18X1.5	AD Thru
	87276A524	HSK100A-CHE 40-4.72	ER40	.157 - 1.023	2.480	4.72	M22X1.5	AD Thru
	87276A726	HSK100A-CHE 50-5.12	ER50	.393 - 1.338	3.070	5.12	M22X1.5	AD Thru

ER Collets **on page 182-186**

ER Nut Wrenches **on page 203**

Coolant tubes **on page 200**

Coolant Tube Wrenches **on page 204**

HSK Holders

HSK-A Shell Mill Holder (DIN 69893 A+C)

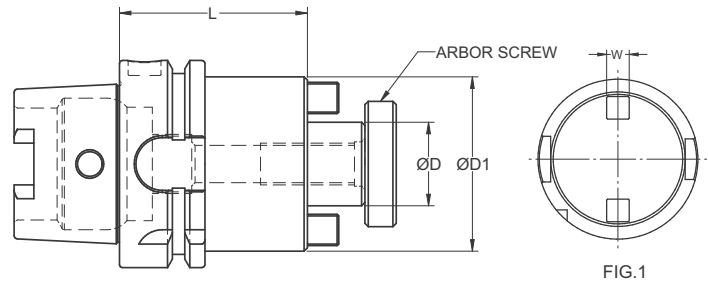

FEATURES

- Balanced to G2.5 @ 25,000 RPM
- TIR < 0.0003"
- Coolant through the center of the body

	Catalog Number	Description	Pilot Size ØD	L (inch)	ØD1 (inch)	W (inch)	Arbor Screw	Coolant Style
HSK40A	8172A5009	HSK40A-SMH 0.500-1.77	0.500	1.77	1.75	0.250	1/4-28	AD Thru
	8172A7510	HSK40A-SMH 0.750-2.00	0.750	2.00	1.75	0.312	3/8-24	AD Thru
	8172A1010	HSK40A-SMH 1.000-2.00	1.000	2.00	2.19	0.375	1/2-20	AD Thru
HSK50A	8173A5009	HSK50A-SMH 0.500-1.77	0.500	1.77	1.75	0.250	1/4-28	AD Thru
	8173A7510	HSK50A-SMH 0.750-2.00	0.750	2.00	1.75	0.312	3/8-24	AD Thru
	8173A1011	HSK50A-SMH 1.000-2.25	1.000	2.25	2.19	0.375	1/2-20	AD Thru
HSK63A	8174A5010	HSK63A-SMH 0.500-2.00	0.500	2.00	1.75	0.250	1/4-28	AD Thru
	8174A7510	HSK63A-SMH 0.750-2.00	0.750	2.00	1.75	0.312	3/8-24	AD Thru
	8174A1011	HSK63A-SMH 1.000-2.25	1.000	2.25	2.19	0.375	1/2-20	AD Thru
	8174A1211	HSK63A-SMH 1.250-2.25	1.250	2.25	2.75	0.500	5/8-18	AD Thru
	8174A1511	HSK63A-SMH 1.500-2.25	1.500	2.25	3.62	0.625	3/4-16	AD Thru
HSK100A	8176A1011	HSK100A-SMH 1.000-2.25	1.000	2.25	2.75	0.375	1/2-20	AD Thru
	8176A1213	HSK100A-SMH 1.250-2.50	1.250	2.50	2.75	0.500	5/8-18	AD Thru
	8176A1513	HSK100A-SMH 1.500-2.50	1.500	2.50	3.94	0.625	3/4-16	AD Thru
	8176A2013	HSK100A-SMH 2.000-2.50	2.000	2.50	4.44	0.750	1 - 14	AD Thru
	8176A2513	HSK100A-SMH 2.500-2.50	2.500	2.50	4.88	1.000	1 - 14	AD Thru

NOTE:

ALL Shell Mill Holders are supplied with coolant through the center up to the arbor screw hole.
 Non-Coolant and Coolant Arbor Screws **on page 202**
 Coolant tubes **on page 200**
 Coolant Tube Wrenches **on page 204**

HSK Holders

HSK-A AccuMill™ Multi-Milling Chuck (DIN 69893 A+C)

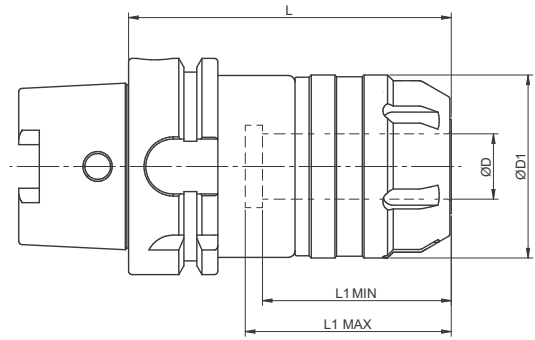

FEATURES

- Balanced to G2.5 @ 25,000 RPM
- Bore tolerance: H6
- T.I.R. < 0.0002"

	Catalog Number	Description	Collet Size	Collet Capacity Range	ØD (inch)	ØD1 (inch)	L (inch)	L1 Min/Max	Coolant Style
HSK63A	9774A2821	HSK63A-MMC 0.750-4.13	MC75	.125 - .625	0.750	2.09	4.13	2.50/2.75	AD Thru
	9774A2824	HSK63A-MMC 0.750-4.72	MC75	.125 - .625	0.750	2.09	4.72	2.50/2.75	AD Thru
	9774A2225	HSK63A-MMC 1.250-4.92	MC125	.125 - 1.00	1.250	2.64	4.92	3.09/3.34	AD Thru
HSK100A	9776A2824	HSK100A-MMC 0.750-4.75	MC75	.125 - .625	0.750	2.09	4.75	2.50/2.75	AD Thru
	9776A2228	HSK100A-MMC 1.250-5.50	MC125	.125 - 1.00	1.250	2.64	5.50	3.09/3.34	AD Thru

AccuMill™ Collets [on page 191-192](#)

AccuMill™ Collet Nut wrenches [on page 201](#)

Coolant tubes [on page 200](#)

Coolant Tube Wrenches [on page 204](#)

HSK-A AccuClamp™ Hydraulic Chuck (DIN 69893 A+C)

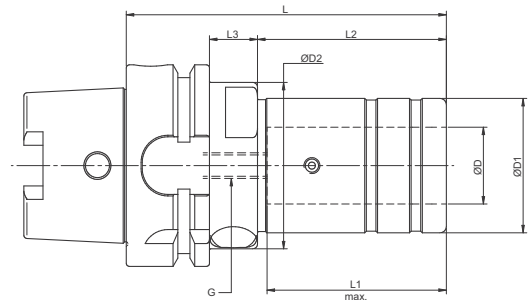

FEATURES

- Balanced to G2.5 @ 25,000 RPM
- Bore tolerance: H6
- T.I.R. < 0.0002"

	Catalog Number	Description	ØD (inch)	ØD1 (inch)	ØD2 (inch)	L (inch)	L1 (inch)	L2 (inch)	L3 (inch)	G (inch)	Coolant Style
HSK50A	6873A2620	HSK50A-HCS 0.375-4.00	0.375	1.18	1.65	4.00	1.57	2.20	0.71	M8X1	AD Thru
	6873A1520	HSK50A-HCS 0.500-4.00	0.500	1.65	-	4.00	1.78	2.91	-	M8X1	AD Thru
	6873A2824	HSK50A-HCS 0.750-4.75	0.750	1.65	1.97	4.75	2.05	2.20	0.78	M8X1	AD Thru
HSK63A	6874A2820	HSK63A-HCS 0.750-4.00	0.750	1.65	2.05	4.00	2.05	2.20	0.78	M8X1	AD Thru
	6874A2225	HSK63A-HCS 1.25-5.00	1.250	2.36	-	5.00	2.44	4.00	-	M8X1	AD Thru
HSK63A Metric	6874A2020	HSK63A-HCS 20-100	20mm	42mm	52mm	100mm	52mm	56mm	18mm	M8X1	AD Thru
HSK100A	6876A2823	HSK100A-HCS 0.750-4.50	0.750	1.65	2.05	4.50	2.05	2.40	0.95	M8X1	AD Thru
	6876A2225	HSK100A-HCS 1.25-5.00	1.250	2.36	2.75	5.00	2.44	2.91	0.95	M8X1	AD Thru

AccuClamp™ Torque wrenches [on page 204](#)

AccuClamp™ Reduction Sleeves [on page 191-192](#)

Coolant tubes [on page 200](#)

Coolant Tube Wrenches [on page 204](#)

HSK Holders

HSK-A Morse Taper Holders (DIN 69893 A+C)

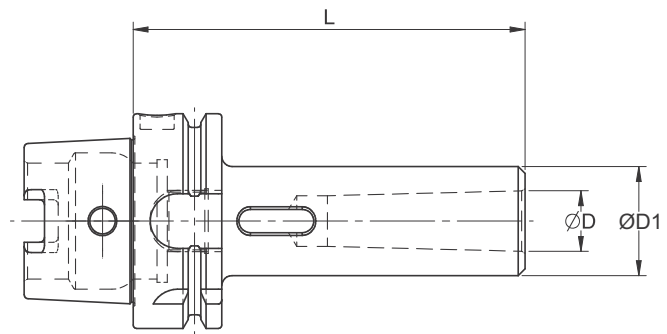

FEATURES

- T.I.R. < 0.0004"

	Catalog Number	Description	MT Socket	ØD (inch)	L (inch)	ØD1 (inch)	Coolant Style
HSK40A	88072A119	HSK40A-MTA 1-3.74	1	0.475	3.74	0.984	N/A
	88072A221	HSK40A-MTA 2-4.33	2	0.700	4.33	1.259	N/A
	88072A327	HSK40A-MTA 3-5.31	3	0.937	5.31	1.574	N/A
HSK50A	88073A119	HSK50A-MTA 1-3.74	1	0.475	3.74	0.984	N/A
	88073A223	HSK50A-MTA 2-4.53	2	0.700	4.53	1.259	N/A
	88073A327	HSK50A-MTA 3-5.31	3	0.937	5.31	1.574	N/A
HSK63A	88074A119	HSK63A-MTA1-3.74	1	0.475	3.74	0.984	N/A
	88074A223	HSK63A-MTA2-4.53	2	0.700	4.53	1.259	N/A
	88074A327	HSK63A-MTA3-5.31	3	0.937	5.31	1.574	N/A
	88074A432	HSK63A-MTA4-6.30	4	1.230	6.30	1.889	N/A
HSK100A	88076A224	HSK100A-MTA 2-4.72	2	0.700	4.72	1.259	N/A
	88076A330	HSK100A-MTA 3-5.91	3	0.937	5.91	1.574	N/A
	88076A434	HSK100A-MTA 4-6.69	4	1.230	6.69	1.889	N/A
	88076A540	HSK100A-MTA 5-7.87	5	1.747	7.87	2.480	N/A

CAT vs HSK-A Extension Holders

Front-End Clamping System

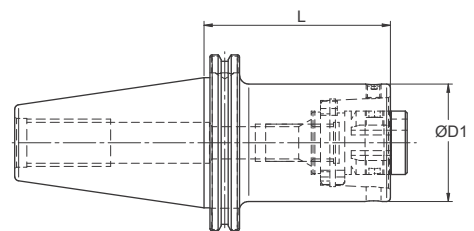

FEATURES

- Balanced to G2.5 @ 25,000 RPM
- T.I.R. < 0.0004"

	Catalog Number	Description	Adaptor	Shank	ØD1 (mm)	L (mm)
CAT40	892474A16	CAT40 EA HSK 63A-80	HSK63A	CAT 40	63	80
CAT50	892676A20	CAT50 EA HSK 100A-100	HSK100A	CAT 50	100	100
CATP40	8913674A16	CATP40 EA HSK 63A-80	HSK63A	CATP 40	63	80
CATP50	8913876A20	CATP50 EA HSK 100A-100	HSK100A	CATP 50	100	100

HSK Holders

HSK 40/E END MILL HOLDERS

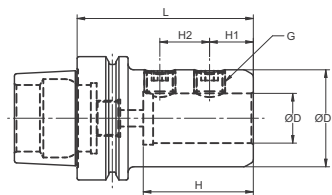

FEATURES

- Balanced to G2.5 @ 25,000 RPM
- Bore tolerance: H6
- T.I.R. < 0.0004"

	Catalog Number	Description	ØD (inch)	L (inch)	ØD1 (inch)	H (inch)	"H1" (inch)	H2 (inch)	G	Coolant Style
HSK40/E Shank	8472E1112	HSK40E-EMH 0.250-2.36	0.250	2.36	0.69	0.87	0.56	-	1/4"-28	AD THRU
	8472E1312	HSK40E-EMH 0.312-2.36	0.312	2.36	1.00	1.06	0.75	-	1/4"-28	AD THRU
	8472E2613	HSK40E-EMH 0.375-2.56	0.375	2.56	1.25	1.49	0.75	-	3/8"-24	AD THRU
	8472E1514	HSK40E-EMH 0.500-2.76	0.500	2.76	1.25	1.73	0.75	-	7/16"-20	AD THRU
	8472E1716	HSK40E-EMH 0.625-3.15	0.625	3.15	1.75	1.89	0.94	-	9/16"-18	AD THRU
	8472E2816	HSK40E-EMH 0.750-3.15	0.750	3.15	1.75	2.01	1.00	-	5/8"-18	AD THRU
	8472E2121	HSK40E-EMH 1.000-4.13	1.000	4.13	1.95	3.00	1.12	1.000	3/4"-16	AD THRU

HSK 40/E ER Collet Chuck

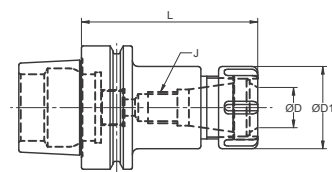

FEATURES

- Balanced to G2.5 @ 25,000 RPM
- T.I.R. < 0.0002"

	Catalog Number	Description	Collet Size	ØD Range	ØD1 (inch)	L (inch)	"J" Adj. Screw	Coolant Style
HSK40/E Shank	87272E111.	HSK40E-CHE 16-55	ER16	3 - 10	28	55	-	AD THRU
	87272E116.	HSK40E-CHE 16-80	ER16	3 - 10	28	80	M10X1.5	AD THRU
	87272E212.	HSK40E-CHE 20-60	ER20	3 - 13	34	50	-	AD THRU
	87272E316.	HSK40E-CHE 25-80	ER25	3 - 16	42	80	M16X2	AD THRU
	87272E420.	HSK40E-CHE 32-100	ER32	3 - 20	50	100	M18X1.5	AD THRU

HSK 40/E Shell Mill Holder

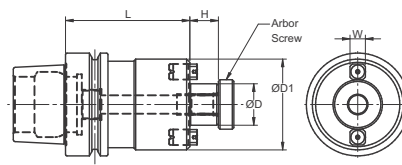

FEATURES

- Balanced to G2.5 @ 25,000 RPM
- T.I.R. < 0.0004"

	Catalog Number	Description	ØD (inch)	L Range	ØD1 (inch)	W (inch)	Arbor Screw	Coolant Style
HSK40/E Shank	8172E5009	HSK40E-SMH 0.500-1.77	0.500	1.77	1.75	0.250	1/4"-28	AD THRU
	8172E7510	HSK40E-SMH 0.750-2.00	0.750	2.00	1.75	0.312	3/8"-24	AD THRU
	8172E1010	HSK40E-SMH 1.000-2.00	1.00	2.00	2.19	0.375	1/2"-20	AD THRU

Notes:

Lined area for notes with horizontal dashed lines.

PTI Taper Holders

PTI End Mill Holder (ISO 26623-1)

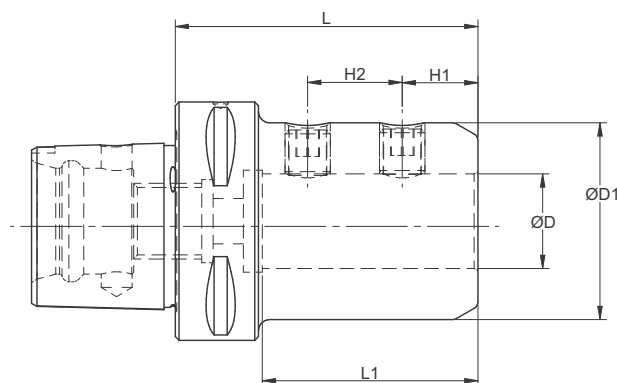

FEATURES

- Balanced to G2.5 @ 25,000 RPM
- T.I.R. < 0.0004"
- Bore tolerance: H6

	Catalog Number	Description	ØD (inch)	L (inch)	L1 (inch)	ØD1 (inch)	H1 (inch)	H2 (inch)	G	Coolant Style
PTI40 Shank	84671115	PTI40-EMH 0.250-3.00	0.250	3.00	0.870	0.690	0.56	-	1/4"-28	AD THRU
	84671316	PTI40-EMH 0.312-3.15	0.312	3.15	1.060	1.000	0.75	-	1/4"-28	AD THRU
	84672616	PTI40-EMH 0.375-3.15	0.375	3.15	1.490	1.000	0.75	-	3/8"-24	AD THRU
	84671516	PTI40-EMH 0.500-3.15	0.500	3.15	1.730	1.750	0.88	-	7/16"-20	AD THRU
	84671713	PTI40-EMH 0.625-2.50	0.625	2.50	1.890	1.620	0.94	-	9/16"-18	AD THRU
	84672817	PTI40-EMH 0.750-3.35	0.750	3.35	2.010	1.750	1.00	-	5/8"-18	AD THRU
PTI50 Shank	84681115	PTI50-EMH 0.250-3.00	0.250	3.00	0.870	0.690	0.56	-	1/4"-28	AD THRU
	84681316	PTI50-EMH 0.312-3.15	0.312	3.15	1.060	1.000	0.75	-	1/4"-28	AD THRU
	84682616	PTI50-EMH 0.375-3.15	0.375	3.15	1.490	1.000	0.75	-	3/8"-24	AD THRU
	84681516	PTI50-EMH 0.500-3.15	0.500	3.15	1.730	1.750	0.75	-	7/16"-20	AD THRU
	84681716	PTI50-EMH 0.625-3.15	0.625	3.15	1.890	1.620	0.94	-	9/16"-18	AD THRU
	84682817	PTI50-EMH 0.750-3.35	0.750	3.35	2.010	1.750	1.00	-	5/8"-18	AD THRU
	84682118	PTI50-EMH 1.000-3.54	1.000	3.54	3.000	1.950	1.12	1.00	3/4"-16	AD THRU
	84682218	PTI50-EMH 1.250-3.54	1.250	3.54	3.000	2.500	1.12	1.00	3/4"-16	AD THRU
PTI63 Shank	84691115	PTI63-EMH 0.250-3.00	0.250	3.00	0.870	0.690	0.56	-	1/4"-28	AD THRU
	84691316	PTI63-EMH 0.312-3.15	0.312	3.15	1.060	1.000	0.75	-	1/4"-28	AD THRU
	84692616	PTI63-EMH 0.375-3.15	0.375	3.15	1.490	1.000	0.75	-	3/8"-24	AD THRU
	84691516	PTI63-EMH 0.500-3.15	0.500	3.15	1.730	1.750	0.75	-	7/16"-20	AD THRU
	84691716	PTI63-EMH 0.625-3.15	0.625	3.15	1.890	1.620	0.94	-	9/16"-18	AD THRU
	84692817	PTI63-EMH 0.750-3.35	0.750	3.35	2.010	1.750	1.00	-	5/8"-18	AD THRU
	84692118	PTI63-EMH 1.000-3.54	1.000	3.54	3.000	1.950	1.12	1.00	3/4"-16	AD THRU
	84692218	PTI63-EMH 1.250-3.54	1.250	3.54	3.000	2.500	1.12	1.00	3/4"-16	AD THRU
	84692319	PTI63-EMH 1.500-3.70	1.500	3.70	3.150	2.750	1.12	1.00	3/4"-16	AD THRU

PTI Taper Holders

PTI ER Collet Holder (ISO 26623-1)

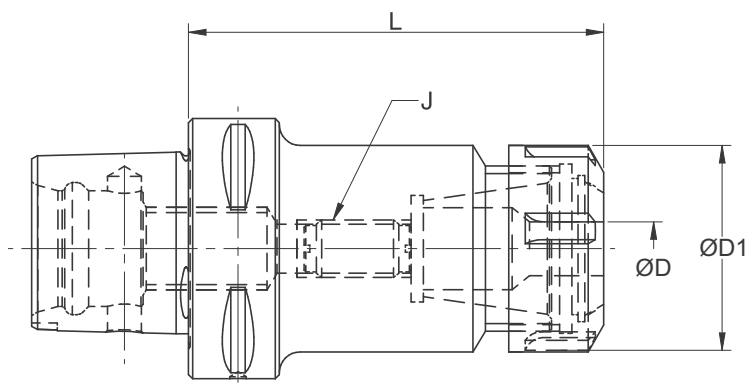

FEATURES

- Balanced to G2.5 @ 25,000 RPM
- T.I.R. < 0.0002"
- Balanced ER Collet Nuts

	Catalog Number	Description	Collet Size	ØD Range (inch)	ØD1	L	J Adj. Screw	Coolant Style
PTI32 SHANK	87266210	PTI32-CHE 20-50	ER20	3 - 13	34	50	-	AD Thru
	87266310	PTI32-CHE 25-50	ER25	3 - 16	42	50	-	AD Thru
PTI40 SHANK	87267114	PTI40-CHE 16-70	ER16	3 - 10	28	70	M10X1.5	AD Thru
	87267210	PTI40-CHE 20-50	ER20	3 - 13	34	50	-	AD Thru
	87267310	PTI40-CHE 25-50	ER25	3 - 16	42	50	-	AD Thru
	87267411	PTI40-CHE 32-55	ER32	3 - 20	50	55	-	AD Thru
PTI50 SHANK	87268112	PTI50-CHE 16-60	ER16	3 - 10	28	60	M10X1.5	AD Thru
	87268114	PTI50-CHE 16-70	ER16	3 - 10	28	70	M10X1.5	AD Thru
	87268120	PTI50-CHE 16-100	ER16	3 - 10	28	100	M10X1.5	AD Thru
	87268124	PTI50-CHE 16-120	ER16	3 - 10	28	120	M10X1.5	AD Thru
	87268212	PTI50-CHE 20-60	ER20	3 - 13	34	60	M12X1.75	AD Thru
	87268214	PTI50-CHE 20-70	ER20	3 - 13	34	70	M12X1.75	AD Thru
	87268220	PTI50-CHE 20-100	ER20	3 - 13	34	100	M12X1.75	AD Thru
	87268224	PTI50-CHE 20-120	ER20	3 - 13	34	120	M12X1.75	AD Thru
	87268226	PTI50-CHE 20-130	ER20	3 - 13	34	130	M12X1.75	AD Thru
	87268227	PTI50-CHE 20-135	ER20	3 - 13	34	135	M12X1.75	AD Thru
	87268311	PTI50-CHE 25-55	ER25	3 - 16	42	55	-	AD Thru
	87268318	PTI50-CHE 25-90	ER25	3 - 16	42	90	M16X2.0	AD Thru
	87268412	PTI50-CHE 32-60	ER32	3 - 20	50	60	-	AD Thru
	87268420	PTI50-CHE 32-100	ER32	3 - 20	50	100	M18X1.5	AD Thru
	87268516	PTI50-CHE 40-80	ER40	4 - 26	63	80	M22X1.5	AD Thru

ER Collets on page 182-186
 ER Nut Wrenches on page 203
 PTI63 and PTI80 Coolant Tubes on page 200

PTI Taper Holders

PTI ER Collet Holder (ISO 26623-1)

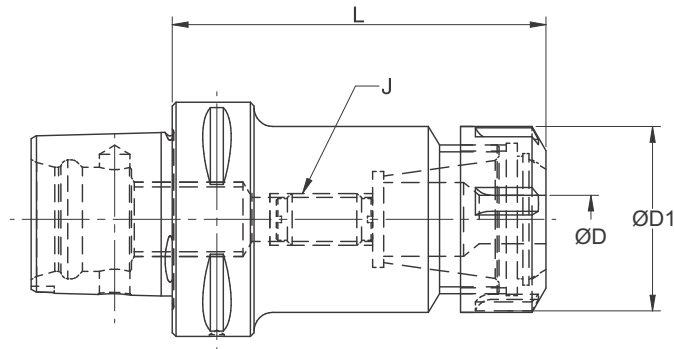

FEATURES

- Balanced to G2.5 @ 25,000 RPM
- T.I.R. < 0.0002"
- Balanced ER Collet Nuts

	Catalog Number	Description	Collet Size	ØD Range (inch)	ØD1	L	J Adj. Screw	Coolant Style
PTI63 SHANK	87269012	PTI63-CHE 11-60	ER11	3 - 7	19	60	M6X1.00	AD Thru
	87269014	PTI63-CHE 11-70	ER11	3 - 7	19	70	M6X1.00	AD Thru
	87269020	PTI63-CHE 11-100	ER11	3 - 7	19	100	M6X1.00	AD Thru
	87269024	PTI63-CHE 11-120	ER11	3 - 7	19	120	M6X1.00	AD Thru
	87269112	PTI63-CHE 16-60	ER16	3 - 10	28	60	M10X1.5	AD Thru
	87269114	PTI63-CHE 16-70	ER16	3 - 10	28	70	M10X1.5	AD Thru
	87269120	PTI63-CHE 16-100	ER16	3 - 10	28	100	M10X1.5	AD Thru
	87269124	PTI63-CHE 16-120	ER16	3 - 10	28	120	M10X1.5	AD Thru
	87269212	PTI63-CHE 20-60	ER20	3 - 13	34	60	M12X1.75	AD Thru
	87269214	PTI63-CHE 20-70	ER20	3 - 13	34	70	M12X1.75	AD Thru
	87269220	PTI63-CHE 20-100	ER20	3 - 13	34	100	M12X1.75	AD Thru
	87269224	PTI63-CHE 20-120	ER20	3 - 13	34	120	M12X1.75	AD Thru
	87269227	PTI63-CHE 20-135	ER20	3 - 13	34	135	M12X1.75	AD Thru
	87269312	PTI63-CHE 25-60	ER25	3 - 16	42	60	-	AD Thru
	87269318	PTI63-CHE 25-90	ER25	3 - 16	42	90	M16X2.0	AD Thru
	87269320	PTI63-CHE 25-100	ER25	3 - 16	42	100	M16X2.0	AD Thru
	87269326	PTI63-CHE 25-130	ER25	3 - 16	42	130	M16X2.0	AD Thru
	87269332	PTI63-CHE 25-160	ER25	3 - 16	42	160	M16X2.0	AD Thru
	87269414	PTI63-CHE 32-70	ER32	3 - 20	50	70	M18X1.5	AD Thru
	87269420	PTI63-CHE 32-100	ER32	3 - 20	50	100	M18X1.5	AD Thru
87269513	PTI63-CHE 40-65	ER40	4 - 26	63	65	-	AD Thru	
87269412	PTI63-CHE 40-80	ER40	4 - 26	63	80	M22X1.5	AD Thru	
87269526	PTI63-CHE 40-130	ER40	4 - 26	63	130	M22X1.5	AD Thru	
PTI80 SHANK	87270213	PTI80-CHE 20-65	ER20	3 - 13	34	65	M12X1.75	AD Thru
	87270314	PTI80-CHE 25-70	ER25	3 - 16	42	70	M16X2.0	AD Thru
	87270414	PTI80-CHE 32-70	ER32	3 - 20	50	70	M18X1.5	AD Thru
	87270420	PTI80-CHE 32-100	ER32	3 - 20	50	100	M18X1.5	AD Thru
	87270432	PTI80-CHE 32-160	ER32	3 - 20	50	160	M18X1.5	AD Thru
	87270446	PTI80-CHE 32-230	ER32	3 - 20	50	230	M18X1.5	AD Thru
	87270466	PTI80-CHE 32-330	ER32	3 - 20	50	330	M18X1.5	AD Thru
	87270514	PTI80-CHE 40-70	ER40	4 - 26	63	70	M22X1.5	AD Thru
	87270520	PTI80-CHE 40-100	ER40	4 - 26	63	100	M22X1.5	AD Thru
	87270524	PTI80-CHE 40-120	ER40	4 - 26	63	120	M22X1.5	AD Thru
87270532	PTI80-CHE 40-160	ER40	4 - 26	63	160	M22X1.5	AD Thru	

ER Collets on page 182-186 | ER Nut Wrenches on page 203 | PTI63 and PTI80 Coolant Tubes on page 200

PTI Taper Holders

PTI Shell Mill Holder (ISO 26623-1)

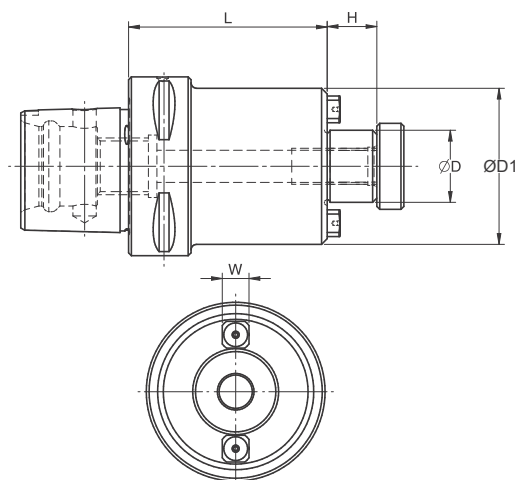

FEATURES

- Balanced to G2.5 @ 25,000 RPM
- < 0.0004"
- Coolant-Thru the Body

	Catalog Number	Description	ØD	ØD1	L	W	H	Coolant Style
PTI40 Shank	81677510	PTI40-SMH 0.750-2.00	0.75	1.75	2	0.312	0.69	AD Thru
PTI50 Shank	81687505	PTI50-SMH 0.750-1.00	0.750	1.75	1.00	0.312	0.69	AD Thru
	81685009	PTI50-SMH 0.500-1.77	0.5	1.75	1.77	0.25	0.56	AD Thru
	81687510	PTI50-SMH 0.750-2.00	0.75	1.75	2	0.312	0.69	AD Thru
	81681008	PTI50-SMH 1.000-1.57	1	2.19	1.57	0.375	0.69	AD Thru
PTI63 Shank	81695009	PTI63-SMH 0.500-1.77	0.5	1.75	1.77	0.25	0.56	AD Thru
	81697510	PTI63-SMH 0.750-2.00	0.75	1.75	2	0.312	0.69	AD Thru
	81697520	PTI63-SMH 0.750-4.00	0.750	1.75	4.00	0.312	0.69	AD Thru
	81691010	PTI63-SMH 1.000-2.00	1	2.19	2	0.375	0.69	AD Thru
	81691210	PTI63-SMH 1.250-2.00	1.25	2.75	2	0.5	0.69	AD Thru
81691510	PTI63-SMH 1.500-2.00	1.5	3.38	2	0.625	0.94	AD Thru	
PTI80 Shank	81707509	PTI80-SMH 0.750-1.77	0.750	1.75	1.77	0.312	0.69	AD Thru
	81707516	PTI80-SMH 0.750-3.15	0.750	1.75	3.15	0.312	0.69	AD Thru
	81701010	PTI80-SMH 1.000-2.00	1.000	2.16	2.00	0.375	0.69	AD Thru
	81701214	PTI80-SMH 1.250-2.75	1.250	2.75	2.75	0.500	0.69	AD Thru
	81701510	PTI80-SMH 1.500-2.00	1.5000	3.38	2.00	0.625	0.94	AD Thru
	81702010	PTI80-SMH 2.000-2.00	2.000	4.44	2.00	0.750	0.94	AD Thru
	81701610	PTI80-SMH 16-50	16 mm	36 mm	50 mm	8 mm	17mm	AD Thru

NOTE:

ALL Shell Mill Holders are supplied with coolant through the center up to the arbor screw hole.
 Represents holders provide with metric allen cap bolt.
 Non-Coolant and Coolant Arbor Screws **on page 202**
 PTI63 and PTI80 Coolant Tubes **on page 200**

PTI Taper Holders

PTI AccuMill™ Multi-Milling Chuck (ISO 26623-1)

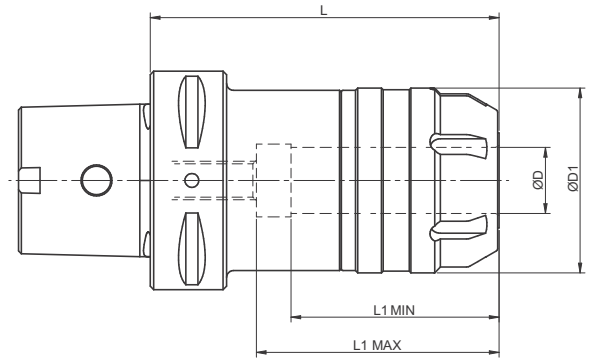

FEATURES

- Balanced to G2.5 @ 25,000 RPM
- T.I.R. < 0.0002"

	Catalog Number	Description	Collet Size	Collet Capacity Range	ØD	ØD1	L	L1 Min.	L1 Max.	Coolant Style
PTI50 Shank Metric	97682021	PTI50-MMC 20-105	MC20	3-16	20	53	105	63	70	AD Thru
	97682024	PTI50-MMC 20-120	MC20	3-16	20	53	120	63	70	AD Thru
	97683225	PTI50-MMC 32-125	MC32	3-25	32	67	125	78	85	AD Thru
PTI63 Shank Metric	97692021	PTI63-MMC 20-105	MC20	3-16	20	53	105	63	70	AD Thru
	97692024	PTI63-MMC 20-120	MC20	3-16	20	53	120	63	70	AD Thru
	97693225	PTI63-MMC 32-125	MC32	3-25	32	67	125	78	85	AD Thru
PTI63 Shank inch	97692821	PTI63-MMC 0.750-4.13	MC75	.125-.625	0.750	2.09	4.13	2.50	2.75	AD Thru
	97692824	PTI63-MMC 0.750-4.72	MC75	.125-.625	0.750	2.09	4.72	2.50	2.75	AD Thru
	97692225	PTI63-MMC 1.250-5.00	MC1.25	.125-1.000	1.250	2.64	5.00	3.09	3.34	AD Thru
PTI80 Shank	97702824	PTI80-MMC 0.750-4.72	MC75	.125-.625	.750	2.09	4.72	2.50	2.75	AD Thru
	97702228	PTI80-MMC 1.250-5.50	MC1.25	.125-1.000	1.250	2.64	5.50	3.09	3.34	AD Thru

AccuMill™ Collets [on page 191-192](#) | AccuMill™ Collet Nut wrenches [on page 201](#)
 PTI63 and PTI80 Coolant Tubes [on page 200](#)

PTI AccuClamp™ Hydraulic Chuck (ISO 26623-1)

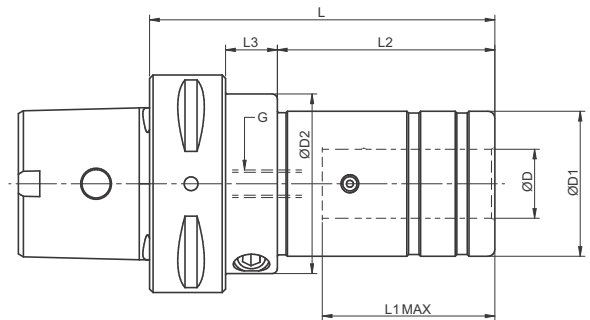

FEATURES

- Balanced to G2.5 @ 25,000 RPM
- Bore tolerance: H6
- T.I.R. < 0.0002"

	Catalog Number	Description	ØD	ØD1	ØD2	L	L1 Max.	L2	L3	G	Coolant Style
PTI50 Shank	68682020	PTI50-HCS 20-100	20	42	50	100	52	56	16	M8x1	AD Thru
	68682820	PTI50-HCS 0.750-3.94	0.750"	1.65	1.97	3.94"	2.05	2.20	0.63	M8x1	AD Thru
	68682520	PTI50-HCS 25-100	25	50	-	100	52	-	-	M8x1	AD Thru
PTI63 Shank	68692020	PTI63-HCS 20-100	20	42	52	100	52	56	22	M8x1	AD Thru
	68692525	PTI63-HCS 25-125	25	52	52	125	52	102	-	M8x1	AD Thru
	68693225	PTI63-HCS 32-125	32	60	-	125	62	102	-	M8x1	AD Thru
	68692820	PTI63-HCS 0.750-3.94	0.750"	42	52	3.94"	52	56	0.86	M8x1	AD Thru
	68692225	PTI63-HCS 1.250-5.00	1.250"	60	-	5.00"	2.44"	4.05"	-	M8x1	AD Thru

AccuClamp™ Torque wrenches [on page 204](#) | AccuClamp™ Reduction Sleeves [on page 191-192](#)
 PTI63 and PTI80 Coolant Tubes [on page 200](#)

PTI Taper Holders

PTI Extension Adapter (ISO 26623-2)

CAT Shank

CAT (ANSI/ASME B5.50-1994) EA PTI(ISO 26623-2)
 Also available in Face Contact CATP Taper
 Drawbar Style Front End

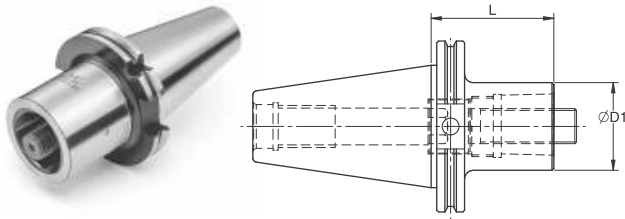

FEATURES

- T.I.R. <math>< 0.0004''</math>
- Balanced to G2.5 @ 25,000 RPM
- Taper shank ground to AT3 accuracy (or better)

Catalog Number	Description	Adaptor	Shank	$\varnothing D1$ (mm)	L (mm)
89246606	CAT40-PTI32-30	PTI32	CAT40	32	30
89246612	CAT40-PTI32-60	PTI32	CAT40	32	60
89266606	CAT50-PTI32-30	PTI32	CAT50	32	30
89266612	CAT50-PTI32-60	PTI32	CAT50	32	60
89246706	CAT40-PTI40-30	PTI40	CAT40	40	30
89246712	CAT40-PTI40-60	PTI40	CAT40	40	60
89266706	CAT50-PTI40-30	PTI40	CAT50	40	30
89266712	CAT50-PTI40-60	PTI40	CAT50	40	60
89246806	CAT40-PTI50-30	PTI50	CAT40	50	30
89246814	CAT40-PTI50-70	PTI50	CAT40	50	70
89266806	CAT50-PTI50-30	PTI50	CAT50	50	30
89266814	CAT50-PTI50-70	PTI50	CAT50	50	70
89246917	CAT40-PTI63-85	PTI63	CAT40	63	85
89266906	CAT50-PTI63-30	PTI63	CAT50	63	30
89266916	CAT50-PTI63-80	PTI63	CAT50	63	80
89267014	CAT50-PTI80-70	PTI80	CAT50	80	70
89267024	CAT50-PTI80-120	PTI80	CAT50	80	120

BT Shank

BT (MAS403) EA PTI(ISO 26623-2)
 Also available in Face Contact BTP Taper
 Drawbar Style Front End

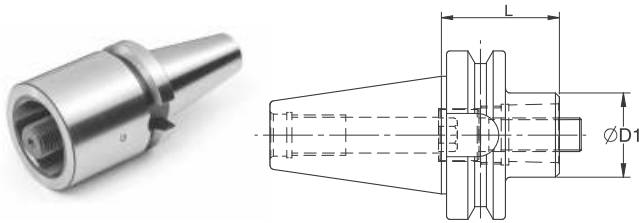

Catalog Number	Description	Adaptor	Shank	$\varnothing D1$ (mm)	L (mm)
89106606	BT30-PTI32-30	PTI32	BT30	32	30
89106612	BT30-PTI32-60	PTI32	BT30	32	60
89126606	BT40-PTI32-30	PTI32	BT40	32	30
89126612	BT40-PTI32-60	PTI32	BT40	32	60
89126706	BT40-PTI40-30	PTI40	BT40	40	30
89126712	BT40-PTI40-60	PTI40	BT40	40	60
89126806	BT40-PTI50-30	PTI50	BT40	50	30
89126814	BT40-PTI50-70	PTI50	BT40	50	70
89126915	BT40-PTI63-75	PTI63	BT40	63	75

HSK Shank

HSK EA PTI (ISO-26623-2)
 Front-End Clamping System

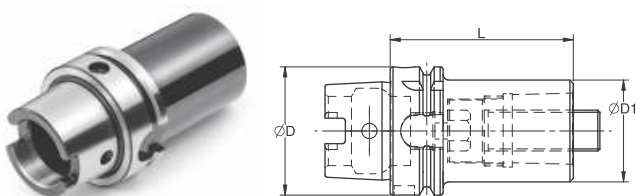

Catalog Number	Description	Adaptor	Shank	$\varnothing D1$ (mm)	L (mm)
8974A6615	HSK63A-PTI32-75	PTI32	63	32	75
8976A6616	HSK100A-PTI32-80	PTI32	100	32	80
8974A6716	HSK63A-PTI40-80	PTI40	63	40	80
8976A6718	HSK100A-PTI40-90	PTI40	100	40	90
8974A6818	HSK63A-PTI50-90	PTI50	63	50	90
8976A6820	HSK100A-PTI50-100	PTI50	100	50	100
8976A6922	HSK100A-PTI63-110	PTI63	100	63	110
8976A7024	HSK100A-PTI80-120	PTI80	100	80	120

Coolant tubes **on page 200**
 Coolant Tube Wrenches **on page 204**

PTI Taper Holders

PTI Extension Front Clamping

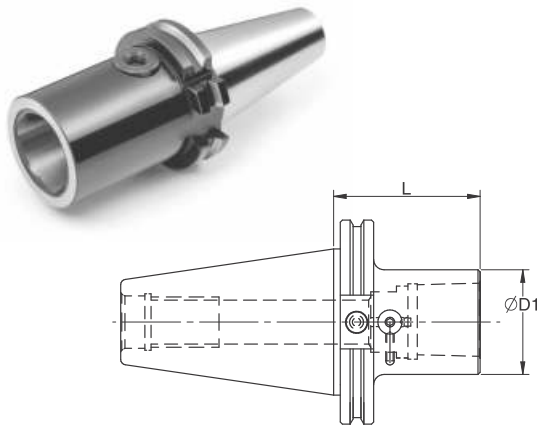

FEATURES

- T.I.R. < 0.0004"
- Balanced to G2.5 @ 25,000 RPM
- Taper shank ground to AT3 accuracy (or better)

BT/CAT Taper

Catalog Number	Description	Adaptor	Shank	$\varnothing D1$ (mm)	L (mm)
BT Shank					
89126816F	BT40-PTI50-FC 80	PIT50	BT40	50	90
89126820F	BT40-PTI50-FC 100	PTI50	BT40	50	100
CAT Shank					
89246816F	CAT40-PTI50-FC 80	PTI50	CAT40	50	80
89266816F	CAT50-PTI50-FC 80	PTI50	CAT50	50	80
89246918F	CAT40-PTI63-FC 90	PTI63	CAT40	63	90
89266921F	CAT50-PTI63-FC 105	PTI63	CAT50	63	105

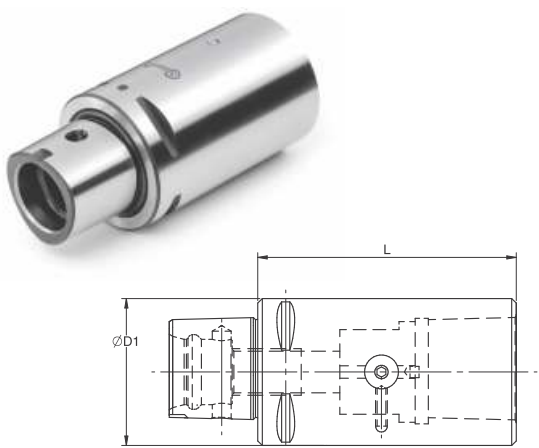

Front Clamping Extension Adaptor

Catalog Number	Description	Adaptor	Shank	$\varnothing D1$ (mm)	L (mm)
205515F	PTI50-PTI50-FC 75	PTI50	PTI50	50	75
206617F	PTI63-PTI63-FC 85	PTI63	PTI63	63	85
208820F	PTI80-PTI80-FC 100	PTI80	PTI80	80	100

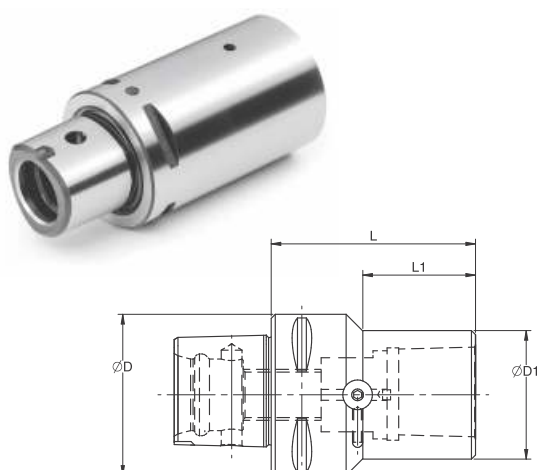

Front Clamping Reduction Adaptor

Catalog Number	Description	Adaptor	$\varnothing D$ (mm)	$\varnothing D1$ (mm)	L (mm)	L1
216516F	PTI63-PTI50-FCRA 80	PTI63	63	50	80	54
218516F	PTI80-PTI50-FCRA 80	PTI80	80	50	80	49
218618F	PTI80-PTI63-FCRA 90	PTI80	80	63	90	63

PTI Taper Holders

PTI Reduction Adaptor

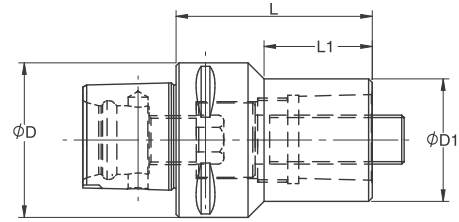

FIG.1

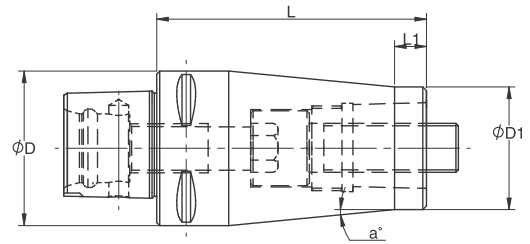

FIG.2

FEATURES

- T.I.R. < 0.0002" (5 microns)

	Catalog Number	Description	Fig.	Adaptor	ϕD (mm)	$\phi D1$ (mm)	L (mm)	L1 (mm)	a°	Weight
PTI REDUCTION ADAPTOR	214311	PTI40-PTI32-RA 55	1	PTI32	40	32	55	31	-	0.5
	214314	PTI40-PTI32-RA 70	2	PTI32	40	32	70	12	6°	0.6
	215312	PTI50-PTI32-RA 60	1	PTI32	50	32	60	35	-	0.6
	215413	PTI50-PTI40-RA 65	1	PTI40	50	40	65	40	-	0.8
	215417	PTI50-PTI40-RA 85	2	PTI40	50	40	85	12	5.4°	1.1
	216314	PTI63-PTI32-RA 70	1	PTI32	63	32	70	39	-	1.1
	216416	PTI63-PTI40-RA 80	1	PTI40	63	40	80	51.5	-	1.2
	216516	PTI63-PTI50-RA 80	1	PTI50	63	50	80	51.5	-	1.5
	216522	PTI63-PTI50-RA 110	2	PTI50	63	50	110	12	4.9°	2.2
	218312	PTI80-PTI32-RA 60	1	PTI32	80	32	60	29.5	-	1.7
	218414	PTI80-PTI40-RA 70	1	PTI40	80	40	70	36.5	-	1.9
	218516	PTI80-PTI50-RA 80	1	PTI50	80	50	80	49.5	-	2.2
	218616	PTI80-PTI63-RA 80	1	PTI63	80	63	80	53	-	2.5
	218624	PTI80-PTI63-RA 120	2	PTI63	80	63	120	12	6.2°	4

PTI Taper Holders

PTI Indexable Static Turning Tools

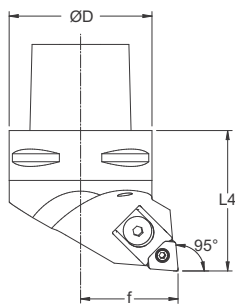

* MCLN STYLE FOR TURNING AND FACING

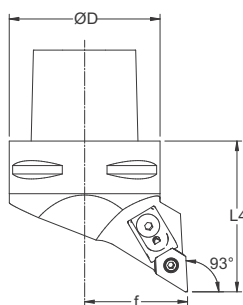
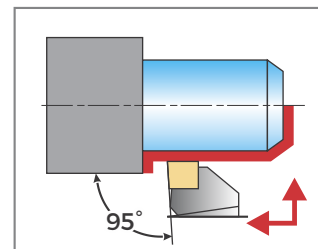

* MDJN STYLE FOR TURNING, FACING, AND PROFILING

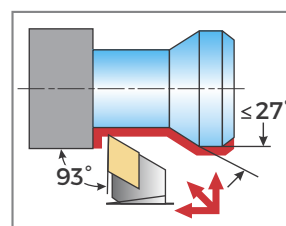

	Catalog Number	Description	Insert IC	L4	f	ØD	Insert	Clamp	Seat	Clamp Screw	Lock Pin
MCLN	74691R45120413	PTI-63 MCLNR-45065-12	0.5	65	45	PTI63	CNxx 1204XX	CMC1204	SCN1204	CSCMC1204	LPSCN1204
	74691L45120413	PTI-63 MCLNL-45065-12	0.5	65	45	PTI63	CNxx 1204XX	CMC1204	SCN1204	CSCMC1204	LPSCN1204
	74701R55120416	PTI-80 MCLNR-55080-12	0.5	80	55	PTI80	CNxx 1204XX	CMC1204	SCN1204	CSCMC1204	LPSCN1204
	74701L55120416	PTI-80 MCLNL-55080-12	0.5	80	55	PTI80	CNxx 1204XX	CMC1204	SCN1204	CSCMC1204	LPSCN1204
MDJN	74692R45110413	PTI63-MDJNR-45065-11	0.375	65	45	PTI63	DNxx1104XX	CMD1104	SDN1104	CSCMD1104	LPSDN1104
	74692L45110413	PTI63-MDJNL-45065-11	0.375	65	45	PTI63	DNxx1104XX	CMD1104	SDN1104	CSCMD1104	LPSDN1104
	74692R45150613	PTI63-MDJNR-45065-15	0.5	65	45	PTI63	DNxx1506XX	CMD1506	SDN1506	CSCMC1204	LPSCN1204
	74692L45150613	PTI63-MDJNL-45065-15	0.5	65	45	PTI63	DNxx1506XX	CMD1506	SDN1506	CSCMC1204	LPSCN1204
	74692R55150616	PTI80-MDJNR-55080-15	0.625	80	55	PTI80	DNxx1506XX	CMD1506	SDN1506	CSCMC1204	LPSCN1204
	74692L55150616	PTI80-MDJNL-55080-15	0.625	80	55	PTI80	DNxx1506XX	CMD1506	SDN1506	CSCMC1204	LPSCN1204

PTI Taper Holders

PTI Indexable Static Turning Tools

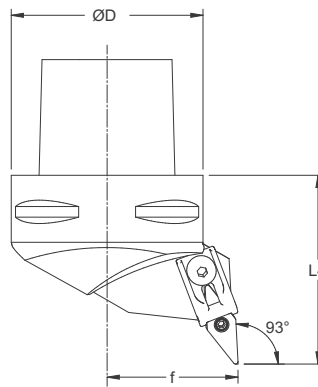

* MVJN STYLE FOR TURNING, FACING, AND PROFILING

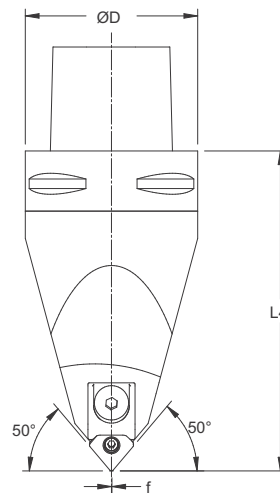

* MCMN STYLE FOR TURNING, FACING AND PROFILING

	Catalog Number	Description	Insert IC	L4	f	ØD	Insert	Clamp	Seat	Clamp Screw	Lock Pin
MVJN	74693R45160413	PTI63-MVJNR-45065-16	16	65	45	PTI63	VNxx1604xx	CMV1604	SVN1604	CSCMD1104	LPSDN1104
	74693L45160413	PTI63-MVJNL-45065-16	16	65	45	PTI63	VNxx1604xx	CMV1604	SVN1604	CSCMD1104	LPSDN1104
	74703R55160416	PTI80-MVJNR-55080-16	16	80	55	PTI80	VNxx1604xx	CMV1604	SVN1604	CSCMD1104	LPSDN1104
	74703L55160416	PTI80-MVJNL-55080-16	16	80	55	PTI80	VNxx1604xx	CMV1604	SVN1604	CSCMD1104	LPSDN1104
MCMN	74684N00120421	PTI50-MCMNN-00105-12	12	105	0	PTI50	CNxx1204xx	CMC1204	SCN1204	CSCMC1204	LPSCN1204
	74694N00120418	PTI63-MCMNN-00090-12	12	90	0	PTI63	CNxx1204xx	CMC1204	SCN1204	CSCMC1204	LPSCN1204
	74694N00120423	PTI63-MCMNN-00115-12	12	115	0	PTI63	CNxx1204xx	CMC1204	SCN1204	CSCMC1204	LPSCN1204

PTI Taper Holders

PTI Indexable Static Turning Tools

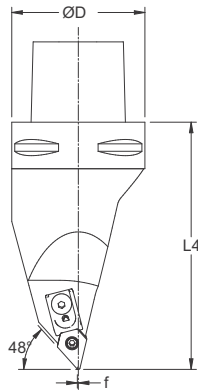

*** MDMN STYLE FOR TURNING,
FACING AND PROFILING**

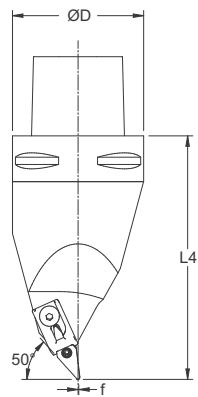

*** MVMN STYLE FOR TURNING,
FACING AND PROFILING**

	Catalog Number	Description	Insert IC	L4	f	ØD	Insert	Clamp	Seat	Clamp Screw	Lock Pin
MDMN	74685N00150623	PTI50-MDMNN-00115-15	15	115	0	PTI50	DNxx-1506xx	CMD1506	SDN1506	CSCMC1204	LPSCN1204
	74695N00150626	PTI63-MDMNN-00130-15	15	130	0	PTI63	DNxx-1506xx	CMD1506	SDN1506	CSCMC1204	LPSCN1204
	74695N33150624	PTI63-MDMNL-33120-15	15	120	33	PTI63	DNxx-1506xx	CMD1506	SDN1506	CSCMC1204	LPSCN1204
	74695N00150632	PTI63-MDMNN-00160-15	15	160	0	PTI63	DNxx-1506xx	CMD1506	SDN1506	CSCMC1204	LPSCN1204
MVMN	74706N00160432	PTI80-MVMNN-00160-16	16	160	0	PTI80	VNxx-1604xx	CMV1604	SVN1604	CSCMD1104	LPSDN1104

PTI Taper Holders

PTI Square Shank Holder (ISO 26623-1)

With Coolant Ports in Body

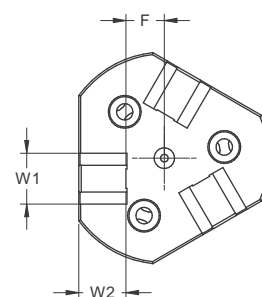
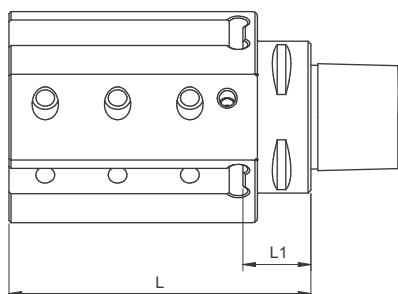
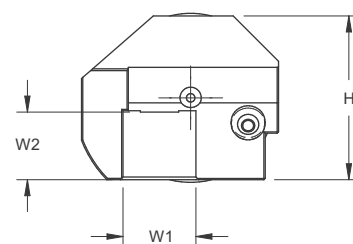
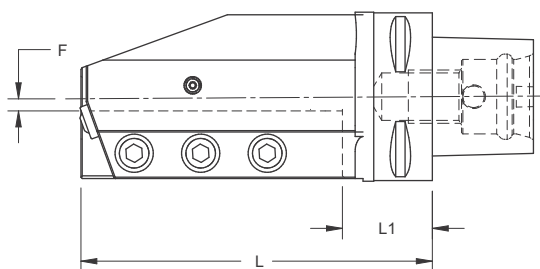
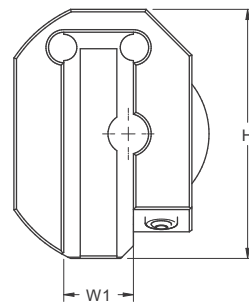
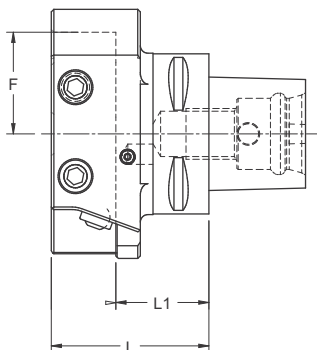

	Catalog Number	Description	L1	L	F	W1	W2	H
ETA Style	7369R402112	PTI63-ETAR1660Y	1.388	2.388	-1.579	1.000	-	3.839
	7369L402112	PTI63-ETALF1660Y	1.388	2.388	-1.579	1.000	-	3.839
STA Style Metric	7269L112020	PTI63-STALF20100Y	25	100	10.75	20	20	60
	7269L062526	PTI63-STALF25130Y	25	130	5.75	25	25	70
	7269R112020	PTI63-STAR20100Y	25	100	10.75	20	20	60
	7269R062526	PTI63-STAR25130Y	25	130	5.75	25	25	70
STA Style Inch	7269L122820	PTI63-STALF12100Y	0.921	3.937	0.460	0.750	0.750	2.362
	7269L052126	PTI63-STALF16130Y	0.906	5.118	0.210	1.000	1.000	2.756
	7269R122820	PTI63-STAR12100Y	0.921	3.937	0.460	0.750	0.750	2.362
	7269R052126	PTI63-STAR16130Y	0.906	5.118	0.210	1.000	1.000	2.756
STA Style Mini-Turret	7269R3162025Y	PTI63-STARF320125Y	28	125	16	20	20	-
	7269L3162025Y	PTI63-STALF320125Y	28	125	16	20	20	-
	7269R3162825Y	PTI63-STARF312125Y	1.10	4.921	0.63	0.750	0.750	-
	7269L3162825Y	PTI63-STALF312125Y	1.10	4.921	0.63	0.750	0.750	-

KTI Taper Holders

KTI End Mill Holder (ISO26622-1)

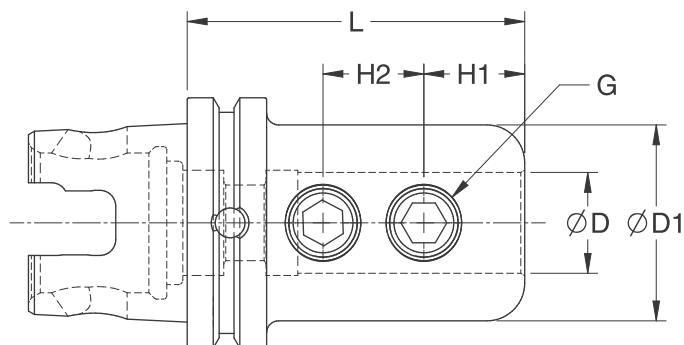

FEATURES

- Balanced to G2.5 @ 25,000 RPM
- Bore tolerance: H6
- T.I.R. < 0.0004"

	Catalog Number	Description	ØD	ØD1	L	H1	H2	G	Coolant Style
KTI 40TS Shank	841412610	KTI40TS-EMH 0.375-1.97	0.375	1.00	1.97	0.75	-	3/8"-24	AD Thru
	841411511	KTI40TS-EMH 0.500-2.16	0.500	1.38	2.17	0.88	-	7/16"-20	AD Thru
	841411712	KTI40TS-EMH 0.625-2.36	0.625	1.63	2.36	0.94	-	9/16"-18	AD Thru
	841412813	KTI40TS-EMH 0.750-2.56	0.750	1.75	2.56	1.00	-	5/8"-18	AD Thru
KTI 50TS Shank	841422610	KTI50TS-EMH 0.375-1.97	0.375	1.00	1.97	0.75	-	3/8"-24	AD Thru
	841421511	KTI50TS-EMH 0.500-2.16	0.500	1.38	2.17	0.88	-	7/16"-20	AD Thru
	841421712	KTI50TS-EMH 0.625-2.36	0.625	1.63	2.36	0.94	-	9/16"-18	AD Thru
	841422812	KTI50TS-EMH 0.750-2.36	0.750	1.75	2.36	1.00	-	5/8"-18	AD Thru
	841422117	KTI50TS-EMH 1.00-3.35	1.000	2.00	3.35	0.88	1.00	5/8"-18	AD Thru
	841422217	KTI50TS-EMH 1.25-3.35	1.250	2.50	3.35	1.00	1.00	3/4"-16	AD Thru
KTI 63XMZ Shank	841502612	KTI63XMZ-EMH 0.375-2.36	0.375	1.00	2.36	0.75	-	3/8"-24	AD Thru
	841501512	KTI63XMZ-EMH 0.500-2.36	0.500	1.38	2.36	0.88	-	7/16"-20	AD Thru
	841501712	KTI63XMZ-EMH 0.625-2.36	0.625	1.63	2.36	0.94	-	9/16"-18	AD Thru
	841502812	KTI63XMZ-EMH 0.750-2.36	0.750	1.75	2.36	1.00	-	5/8"-18	AD Thru
	841502117	KTI63XMZ-EMH 1.00-3.35	1.000	2.00	3.35	0.88	1.00	5/8"-18	AD Thru
	841502217	KTI63XMZ-EMH 1.25-3.35	1.250	2.50	3.35	1.00	1.00	3/4"-16	AD Thru

KTI Taper Holders

KTI ER Collet Holder (ISO 26622-1)

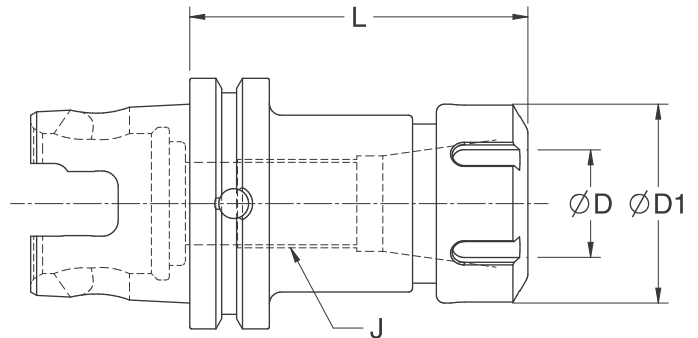

FEATURES

- Balanced to G2.5 @ 25,000 RPM
- T.I.R. < 0.0002"
- AD coolant thru the spindle
- Balanced ER Collet Nuts

	Catalog Number	Description	Collet Size	ØD Range	ØD1 (inch)	L	J (inch)	Coolant Style
KTI 40TS Shank	872141309	KTI40TS-CHE 25-1.77	ER25	.118-.275	1.653	1.77	11/16-16LH	AD Thru
	872141412	KTI40TS-CHE 32-2.36	ER32	.118-.787	1.969	2.36	7/8-16LH	AD Thru
KTI 50TS Shank	872142310	KTI50TS-CHE 25-1.97	ER25	.118-.629	1.653	1.97	11/16-16LH	AD Thru
	872142412	KTI50TS-CHE 32-2.36	ER32	.118-.787	1.969	2.36	7/8-16LH	AD Thru
	872142514	KTI50TS-CHE 40-2.76	ER40	.157-1.023	2.48	2.76	1.1/8-16LH	AD Thru
KTI 63XMZ Shank	8721500M12	KTI63XMZ-CHE 11M-2.36	ER11	.118-.275	0.63	2.36	5/16-24LH	AD Thru
	872150112	KTI63XMZ-CHE 16-2.36	ER16	.118-.393	1.10	2.36	7/16-16LH	AD Thru
	8721501M12	KTI63XMZ-CHE 16M-2.36	ER16	.118-.393	0.866	2.36	7/16-16LH	AD Thru
	872150212	KTI63XMZ-CHE 20-2.36	ER20	.118-.511	1.338	2.36	9/16-16LH	AD Thru
	872150312	KTI63XMZ-CHE 25-2.36	ER25	.118-.629	1.653	2.36	11/16-16LH	AD Thru
	872150418	KTI63XMZ-CHE 32-3.54	ER32	.118-.787	1.969	3.54	7/8-16LH	AD Thru
	872150518	KTI63XMZ-CHE 40-3.54	ER40	.157-1.023	2.48	3.54	1.1/8-16LH	AD Thru

ER Collets on page 182-186
ER Nut Wrenches on page 203

KTI Taper Holders

KTI TG Collect Chuck (ISO 26622-1)

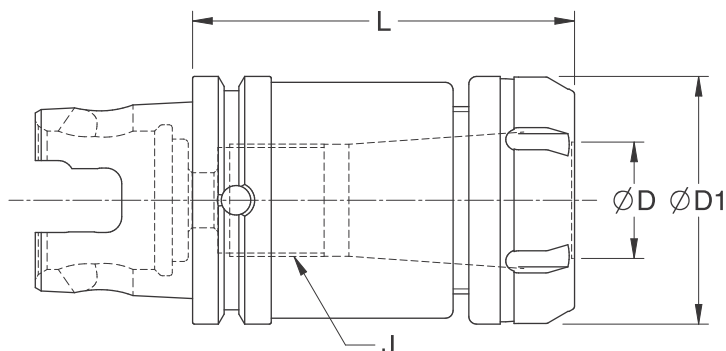

FEATURES

- Balanced to G2.5 @ 25,000 RPM
- T.I.R. < 0.0002"

Catalog Number	Description	Collet Series	ØD Range	ØD1	L	J	Coolant Style
873150320	KTI63XMZTG100100Y	TG100	0.250-1.000	2.48	3.937	1.1/8-1.6LH	AD Thru

KTI Shell Mill Holder (ISO 26622-1)

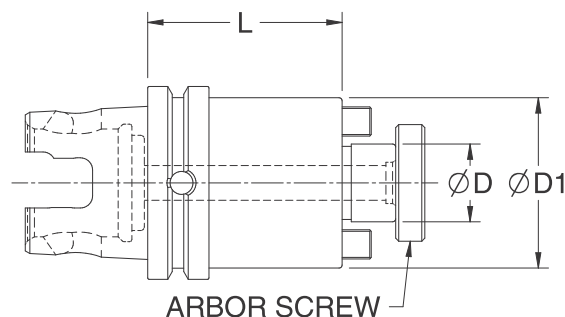
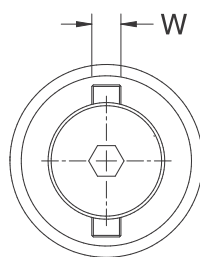

FEATURES

- Balanced to G2.5 @ 25,000 RPM
- T.I.R. < 0.0004"

	Catalog Number	Description	ØD	ØD1	L	W	Arbor Screw	Coolant Style
KTI 40TS Shank	811415005	KTI40TS-SMH .500-1.024	0.500	1.44	1.024	0.250	¼-28	AD Thru
	811417505	KTI40TS-SMH .750-1.024	0.750	1.75	1.024	0.312	3/8-24	AD Thru
	811411006	KTI40TS-SMH 1.00-1.260	1.000	2.19	1.260	0.375	½-20	AD Thru
KTI 63XMZ Shank	811505006	KTI63XMZ-SMH .500-1.25	0.500	1.44	1.25	0.250	¼-28	AD Thru
	811507506	KTI63XMZ-SMH .750-1.25	0.750	1.75	1.25	0.312	3/8-24	AD Thru
	811501013	KTI63XMZ-SMH 1.00-2.50	1.000	2.19	2.50	0.375	½-20	AD Thru
	811501213	KTI63XMZ-SMH 1.25-2.50	1.250	2.75	2.50	0.500	5/8-18	AD Thru

NOTE:

ALL Shell Mill Holders are supplied with coolant through the center up to the arbor screw hole.

Non-Coolant and Coolant Arbor Screws **on page 202**

KTI Taper Holders

KTI Extension Front Clamping

Front-End Clamping System

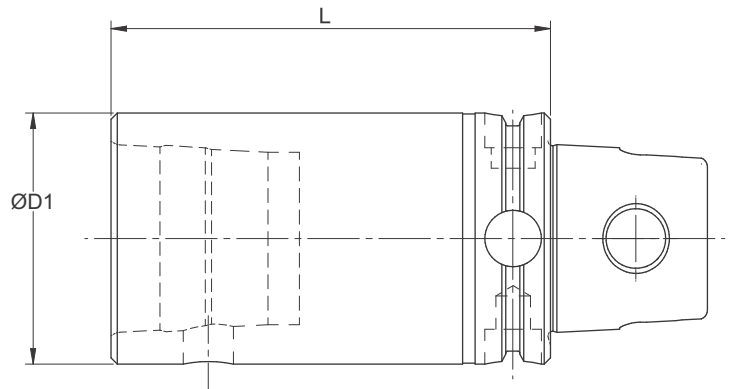

Model Front Clamping Extension Adaptor

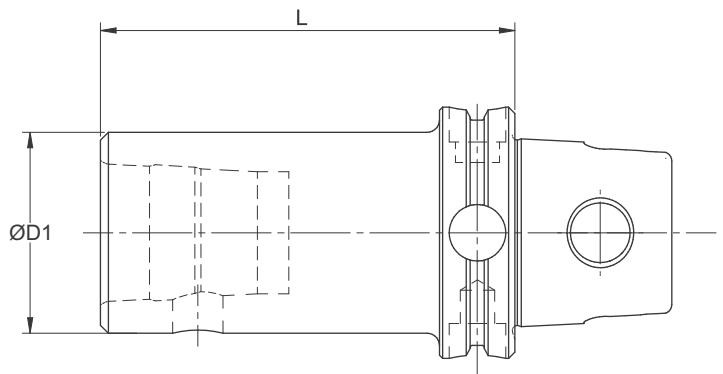

Model Front Clamping Reduction Adaptor

FEATURES

- T.I.R. < 0.0004"

	Catalog Number	Description	Adaptor	KTI-TS	ØD1 (mm)	L (mm)	Wrench
KTI Shank	8914114112	KTI40TS-EXT 40-60	KTI40	KTI40	40	60	6mm
	8914114116	KTI40TS-EXT 40-80	KTI40	KTI40	40	80	6mm

	Catalog Number	Description	Adaptor	KTI-TS	ØD1 (mm)	L (mm)	Wrench
KTI Shank	2114114014	KTI40TS-RED 32-70	KTI40TS	32	32	80	5mm

KTI Taper Holders

KTI Static Indexable Turning Tools (ISO 26622-1)

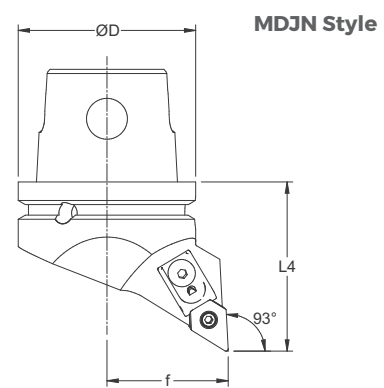
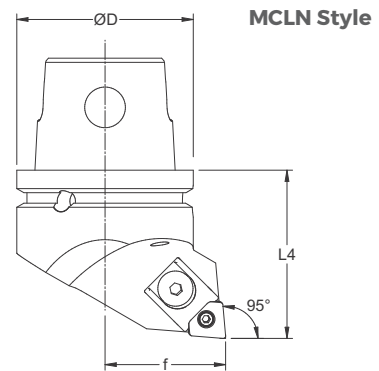

	Catalog Number	Description	L4	$\varnothing D$	f	Insert	Clamp	Seat	Clamp Screw	Lock Pin
MCLN Style	741501R43120412	KTI63XMZ-MCLNR-1260Y	60	63	43	CNxx120408	CMC1204	SCN1204	CSCMC1204	LPSCN1204
	741501L43120412	KTI63XMZ-MCLNLF-1260Y	60	63	43	CNxx120408	CMC1204	SCN1204	CSCMC1204	LPSCN1204

	Catalog Number	Description	L4	$\varnothing D$	f	Insert	Clamp	Seat	Clamp Screw	Lock Pin
MDJN Style	741502R43150412	KTI63XMZ-MDJNR-1560Y	60	63	43	DNxx150408	CMD1504	SDN1504	CSCMC1204	LPSCN1204
	741502L43150412	KTI63XMZ-MDJNL-1560Y	60	63	43	DNxx150408	CMD1504	SDN1504	CSCMC1204	LPSCN1204

KTI Taper Holders

KTI Static Indexable Turning Tools (ISO 26622-1)

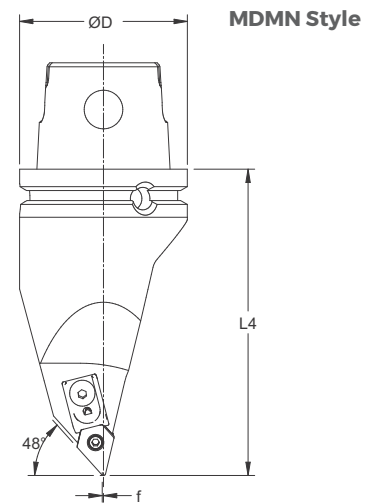
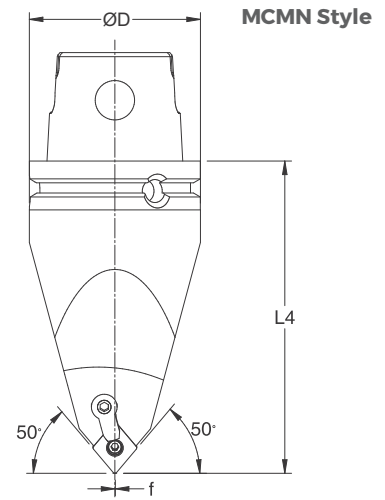

	Catalog Number	Description	L4	ØD	f	Insert	Clamp	Seat	Clamp Screw	Lock Pin
MCMN Style	741504N120423	KTI63XMZ-MCMNMF12115Y	4.528	2.48	0	CNxx120408	CMC1204	SCN1204	CSCMS1204	LPSCN1204

	Catalog Number	Description	L4	ØD	f	Insert	Clamp	Seat	Clamp Screw	Lock Pin
MDMN Style	741505R00150423	KTI63XMZ-MDMNR1504115Y	4.528	2.48	0	DNxx150408	CMD1504	SDN1504	CSCMC1204	LPSCN1204
	741505R00150623	KTI63XMZ-MDMNR1506115Y	4.528	2.48	0	DNxx150608	CMD1506	SDN1506	CSCMC1204	LPSCN1204
	741505L00150423	KTI63XMZ-MDMNLF1504115Y	4.528	2.48	0	DNxx150408	CMD1504	SDN1504	CSCMC1204	LPSCN1204
	741505L00150623	KTI63XMZ-MDMNLF1506115Y	4.528	2.48	0	DNxx150608	CMD1506	SDN1506	CSCMC1204	LPSCN1204

KTI Taper Holders

KTI Static Indexable Turning Tools (ISO 26622-1)

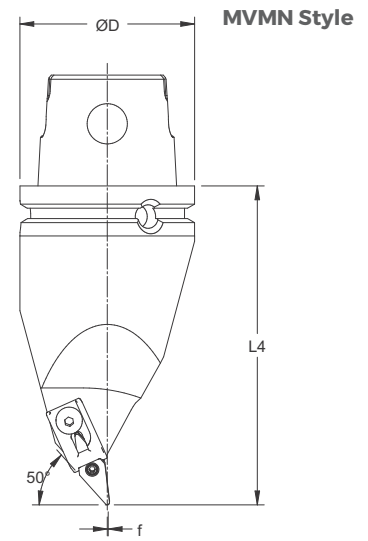

	Catalog Number	Description	L4	ØD	f	Insert	Clamp	Seat	Clamp Screw	Lock Pin
MVMN Style	741506R00160423	KTI63XMZ-MVMNR16115Y	4.528	2.48	0	VNxx160408	CMV1604	SVN1604	CSCMD1104	LPSDN1104
	741506L00160423	KTI63XMZ-MVMNLF16115Y	4.528	2.48	0	VNxx160408	CMV1604	SVN1604	CSCMD1104	LPSDN1104
	741506N160423	KTI63XMZ-MVMNMF16115Y	4.528	2.48	0	VNxx160408	CMV1604	SVN1604	CSCMD1104	LPSDN1104

KTI Taper Holders

KTI Square Shank Holder (ISO 26622-1)

Coolant-Thru Ports in the Body

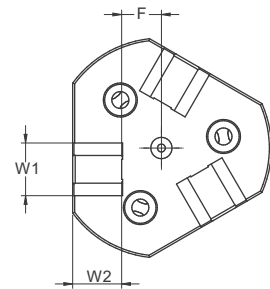
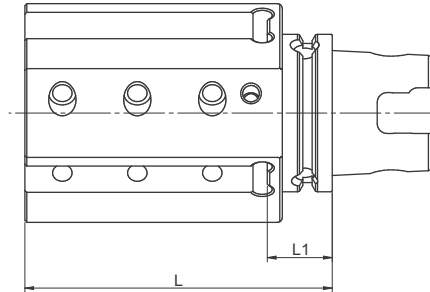
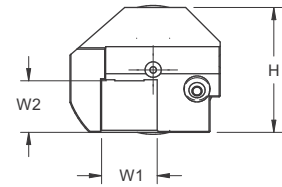
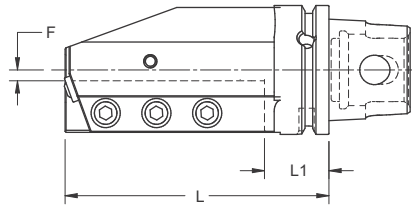
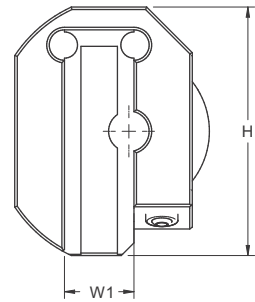
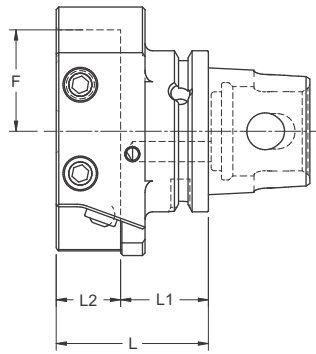

	Catalog Number	Description	L1	L	F	W1	W2	H
ETA Style	73150R402112	KTI63XMZ-ETAR1660Y	1.388	2.388	-1.579	1.000	-	3.839
	73150L402112	KTI63XMZ-ETALF1660Y	1.388	2.388	-1.579	1.000	-	3.839
STA Style Metric	72150L112020	KTI63XMZ-STALF20100Y	25	100	10.75	20	20	60
	72150L062526	KTI63XMZ-STALF25130Y	25	130	5.75	25	25	70
	72150R112020	KTI63XMZ-STAR20100Y	25	100	10.75	20	20	60
	72150R062526	KTI63XMZ-STAR25130Y	25	130	5.75	25	25	70
STA Style Inch	72150L122820	KTI63XMZ-STALF12100Y	0.921	3.937	0.460	0.750	0.750	2.362
	72150L052126	KTI63XMZ-STALF16130Y	0.906	5.118	0.210	1.000	1.000	2.756
	72150R122820	KTI63XMZ-STAR12100Y	0.921	3.937	0.460	0.750	0.750	2.362
	72150R052126	KTI63XMZ-STAR16130Y	0.906	5.118	0.210	1.000	1.000	2.756
STA Style Inch	72150R3162026y	KTI63XMZ-STARF320130Y	33	130	16	20	0.750	-
	72150L3162026Y	KTI63XMZ-STALF320130Y	33	130	16	20	1.000	-
	72150R3162826Y	KTI63XMZ-STARF312130Y	1.30	5.12	0.63	0.750	0.750	-
	72150L3162826Y	KTI63XMZ-STALF312130Y	1.30	5.12	0.63	0.750	0.750	-

AccuGrip™ Shrink Fit Technology Offering

The Premise of Shrink Fit Technology

Heat shrinking of metal has been around for many decades and is not new to manufacturing processes. In 1992 the beginning of the development of shrink fit technology with regards to metalworking cutting tools was started and then patented several years later. This tool-clamping technology was recently implemented with quick-change tool holders used in everyday machining operations and part processing. It is a cylindrical clamping design using no mechanical clamping systems and relying strictly on physical geometric surface contact to create the accuracy and gripping strength for a very effective high-speed machining system.

The shrink fit process starts by simply applying a heat source (induction heating is most accurate and most controllable) to precisely heat the material of the tool clamping holder to allow the ID bore to open. This bore is slightly smaller (microns) than the shank of the cutting tool. By opening the bore of the tool clamping holder, the plane of the tool shank can slide into the bore replacing the plane of the bore ID surface. This “dimensional interference” between tool shank and tool clamping bore ID creates an extremely tight connection once the tool assembly cools back to room temperature. Gripping force on cutting tool shank after shrink process is completed will exceed 10,000 lbs. of force for excellent tool shank grip and minimize tool slippage.

Once the tool clamping holder shrinks back to its “normal size” – the memory of the steel allows the material to return its original dimensional size (as long as the tool clamping material and area is not over heated causing the metallurgical construction of the steel to change and “lose” its memory). Since the tool shank and the tool clamping bore are in the same dimensional plane, this interference “fit” becomes the physical clamping system, holding the cutting tool shank 360° around the tool shank. This clamping force is equally distributed around the shank and up and down the bore between the tool shank and bore surface.

Since the tool clamping bore surface expands and contracts back to its original dimensional position after the heating and cooling cycle and the heat temperature never exceeds the elastic range of the tool clamping holder material, thousands of “shrink cycles” can be performed without mechanical wear or physical damage being done to the clamping system.

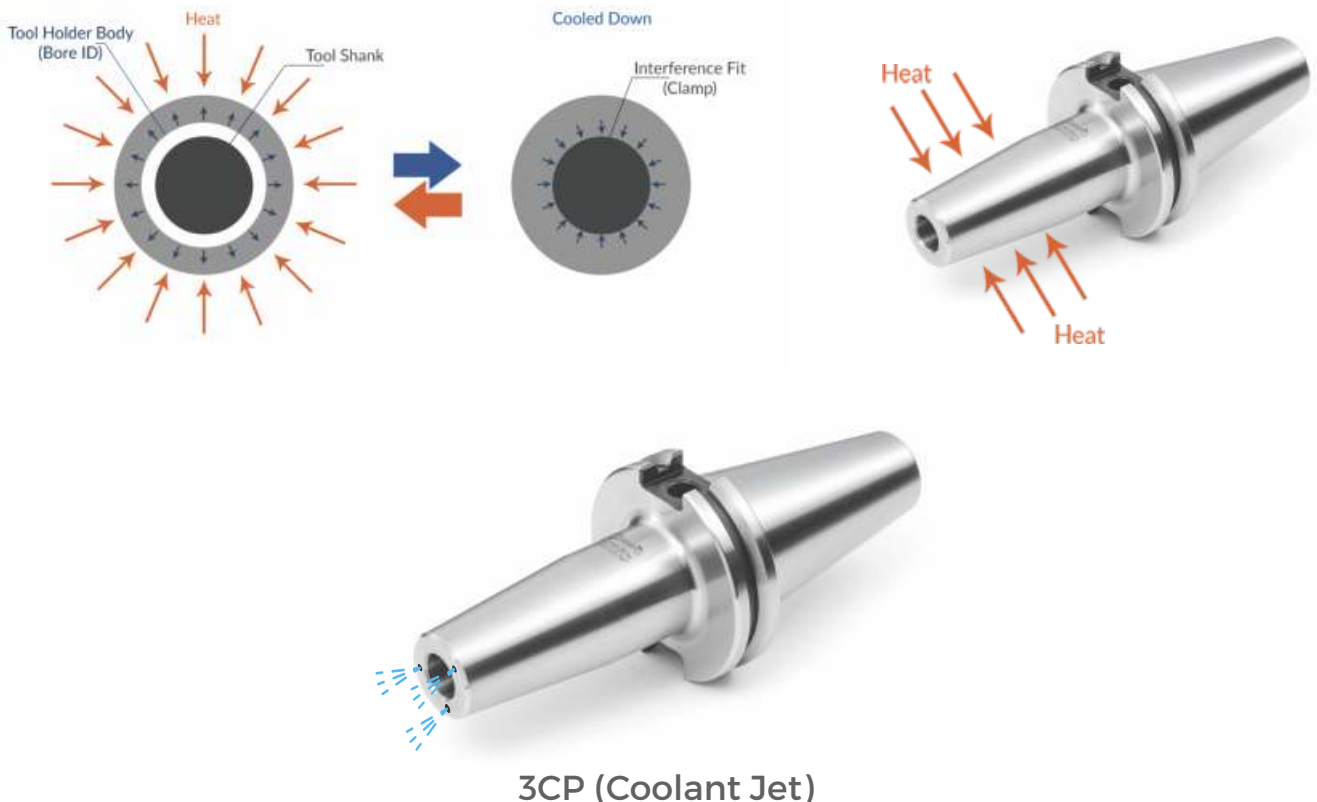

AccuGrip™ Shrink Fit Technology Offering

Shrink Fit Tooling Advantages

- Assembly creates single mono-block tool system that is more accurate in TIR cylindrically than other tool clamping system known.
- Clamping forces are greater than mechanical systems using collets, hydraulic pressure, or even “press-fit” interference technology.
- Lowest TIR runout of any tool clamping system and allows 360° surface contact between tool shank and tool holder bore.
- Excellent tool clamping system for high-speed machining due the excellent symmetrical design of the holder and no mechanical parts to change initial balanced weight.
- Slim and short tool holder profiles are achievable since there is no need for moveable parts to clamp the cutting shank.

Shrink fit technology enables machining applications and processes at greater speeds, higher feed rates while providing improved surface finish. Its high balance design and great TIR accuracy allow extended cutting tool life as well as improved machine spindle life.

Increasing Tool Life

Two main reasons for using a shrink fit tool holder are to increase tool life and to improve circular rotation of a tool. Typical industry observations have been that there is a 10% loss of tool life for every 0.0001" of T.I.R (Total Indicator Runout) in a machining application. In some applications, shrink fit tool holders deliver 4 to 7 times the tool life of other tool holding technologies. Shrink fit tool holders also center the rotating tool more accurately which balances the cutting forces on the tool. This translates into lower machining vibrations with better tool centerline positions often measured in microns.

Shrink Fit Holders Advantages

Improvements in tool life, cutting ability and surface finish mean less wear and tear on the tool holder (Taper Fretting), and machine spindle bearings. This is due to the tool holder's greater clamping power compared to other tool holding methods and superior overall rigidity. Additionally, these holders have a maximum T.I.R. of 0.0001" (25.4µM), and are balanced to 25,000 RPM.

Tool holder designs

Slim design usually incorporates a 3° clearance angle on the exterior of the shrink holder body. With a thinner body wall, this tool design is excellent for close work piece machining where tool holder and work piece clearance are critical.

Well balanced design and maintains balance even after insertion of most cutting tools due to no mechanical parts to change balance.

Standard design holders feature a 4.5° tool body angle for most efficient shrink rates and maximum tool shank rigidity for most applications.

Heavy-duty designs offer a thick tool body wall for maximum tool shank gripping strength and most rigid, vibration dampening effectiveness.

AccuKool Coolant Ports are available upon request. These coolant holes travel through the body of the shrink fit holder and exit at the tip of the shrink fit body.

There are three coolant ports per tool and are angled at a 3 degree angle so the coolant holes are central between the ID diameter and the OD diameter maximizing wall thickness between ID and holes.

The 3 degree angle is also beneficial because the exiting of the coolant is directed at 2 times the diameter of the cutting tool shank for maximum coolant flow into the cutting flutes.

By maximizing the coolant flow into the cutting tool flutes, we maximize coolant flow to and along the cutting edges for maximum coolant benefit and chip removal.

AccuKool port can handle up to 200psi coolant pressure effectively.

AccuGrip™ Shrink Fit Technology Offering

Shrink Fit Heat-Activated Systems

There have been multiple types of heating systems to create the required heat temperature to open the shrink fit bore to allow the cutting tool shank to slide into it. Open flames, hot sand, hot air, and induction coils. When considering a heating and cooling system for your shrink fit tools, operator safety, accurate heat control in temperature and time, and simplicity and efficiency are key concerns. Induction coils and solution cooling are two for the most efficient and most accurate method of heating and cooling shrink fit tool holders.

Induction coil systems offer shorter cycle times, less cooling downtime, and localize heating. Integrated with a cooling system using air or solution make it simple and safe tool clamping system.

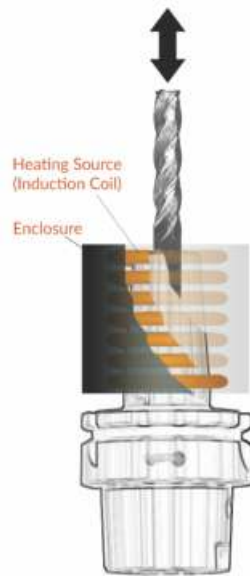

What this means to our customers

Utilizing shrink fit tool holders in your machining processes, you have a higher confidence in our "lights out" machining processes which translates into predictable tool life, production levels and shorter delivery schedules. You can also produce parts with greater positional machined accuracy.

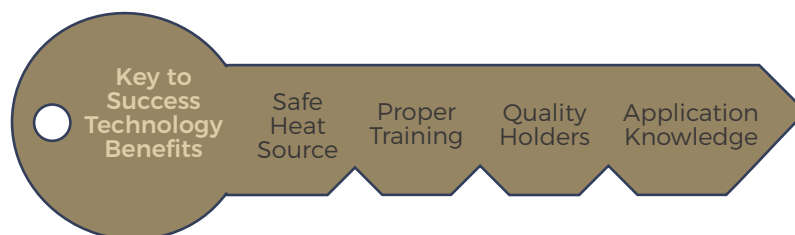

Shrink Fit Unit Technology by Diebold



Passion for Perfection



Diebold / Accutek Shrink Fit Technology: The Smart Concept

Our innovation and motivation Digitization for more process reliability and easy like a smartphone.



Digitization of tool management is the big focus of development. For our US1100 series shrink machines, completely new user interfaces have been developed as touch displays.

The devices are controlled with the tap of just one button. This ensures that even inexperienced operators can safely shrink tools in and out. Operating errors that have often occurred in the past and have led to overheating of the tool holders are thus excluded. By tapping the start symbol on the display, the shrinking process with the subsequent cooling process starts fully automatically. The patented pyrometer technology with TempControl in the coil measures the surface temperature of the chuck during the shrinking process and controls the process. As a result, only the maximum set target temperature is reached, and the bore is kept open for a longer period of time. Overheating of the tool holders due to operating errors is thus excluded. As a result of the regulation to a target value, no further parameter selection is required by the user over time and/or performance.

The devices with automatic cooling are equipped with monitoring functions to ensure that the tool holders are safely cooled after the shrinking process and that the operator cannot burn himself when removing the tools.

Diebold One Touch is the most innovative operation for shrink devices on the market.

Tool Shrinking made easy



We offer a vast range of shrink devices and shrink tools that leave nothing to be desired by users.

Our next generation US 1100 shrink machine is brand new and is available in vertical and horizontal versions. With these devices you can just shrink. With our TubeChiller® you can shrink and immediately cool without the operator coming into contact with the hot shrink holder.

Pyrometer technology is our latest technology for automatic shrinking with direct temperature monitoring, a worldwide unique solution for reliable and particularly gentle tool shrinking. The right device for every user and every budget can be found among the various device variants and performance classes. With these device lines we are the technological world market leader for shrink technology



Overview OneTouch Display

OneTouch

- ⇒ no more operating errors
- ⇒ no overheating of the shrink holders
- ⇒ no selection of parameters necessary

OneTouch is a new operating mode in the touch display in conjunction with TempControl (Pyrometer Control).

In addition to the basic function, this has additional features:

- OneTouch: shrink process with just one push of a button
- Target mode: shrinking up to an individually defined target temperature
- Cooling with the TubeChiller® (option) starts automatically without any further input
- **NEW SteadyFunction:**
Maintaining the target temperature > Longer fitting time

Touch-Display

User-friendly menu navigation with modern touch design

- Graphical visualization of the shrinking and cooling process. Simple and optionally expandable parameter input with USB Numpad.
- User-friendly creation of individual parameter lists with own names (optionally with external keyboard)
- Hiding and showing parameter lists
- I 4.0 Ready through Ethernet interface and data exchange
- Customization options: Dark design (Dark Theme)
- Avoid operating errors through individual menu configuration
- Authorization concept with password
- Handsfree operation with foot switch

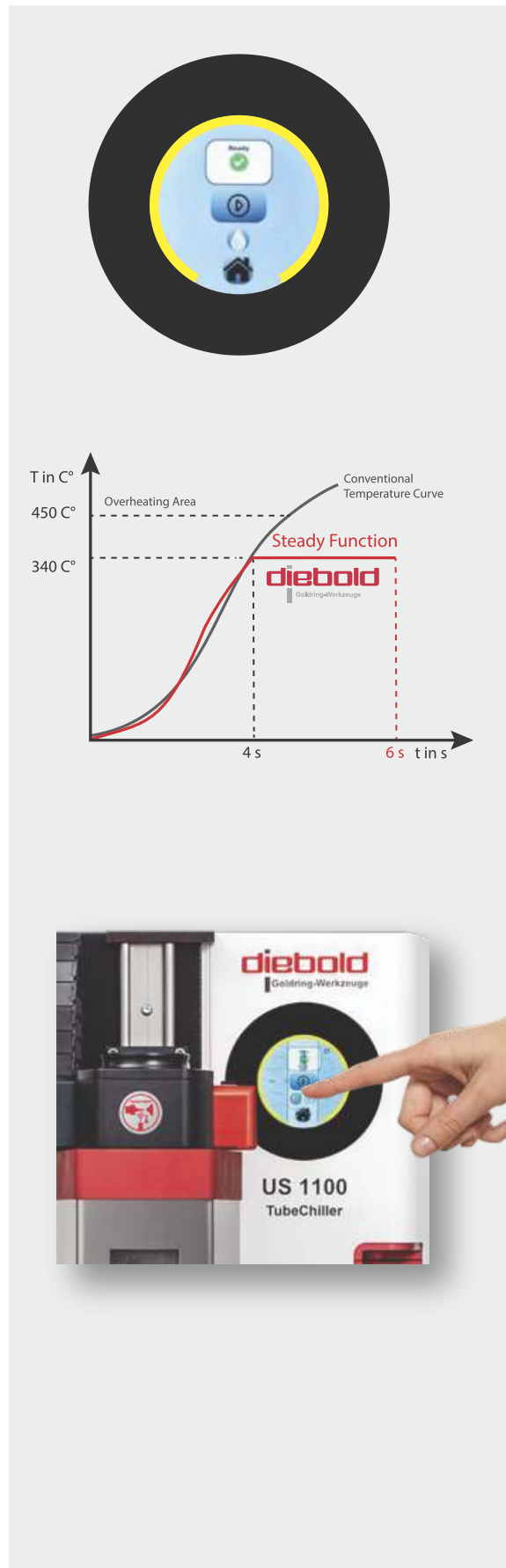

TempControl Safety Function in the Shrink Fit Unit

TempControl ensures that only the necessary temperature is used for the shrink process. The temperature of the shrink fit chuck is continuously measured by TempControl during the inductive heating process. As soon as the shrink chuck has reached the predefined temperature, the heating process is automatically terminated. Overheating of the chuck is impossible.

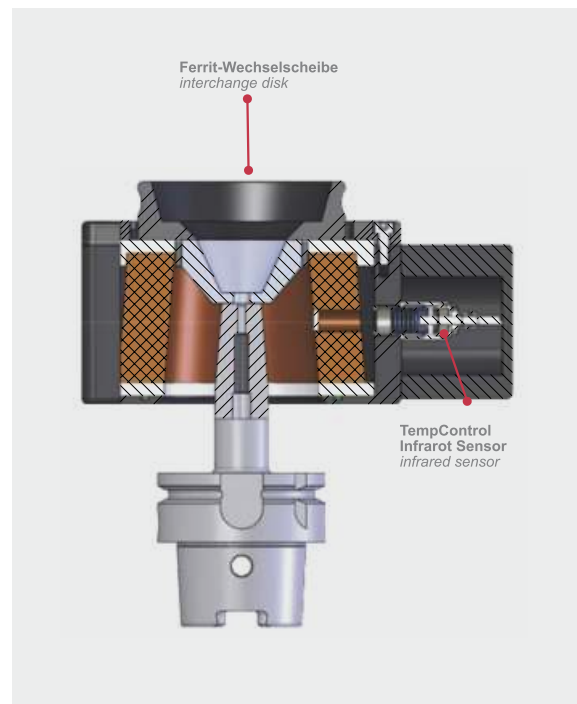

Important Note

TempControl (Pyrometer) is only included in the OneTouch Package.

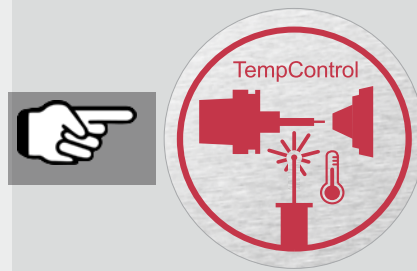

Basic II Display

In terms of menu navigation and basic functionality, the Basic Display II has the same functions as the previous display of the US1100 devices.

There are following features:

- Trouble-free operation by parameter mode (chuck + diameter) and manual mode (time + power)
- Latest digital technology replaces old microcontroller
- Operation with USB-numpad possible. This allows the Numpad to be placed in a position convenient for the operator.
- Hands Free operation with foot switch



Shrink Fit Unit with Integrated Watercooler TubeChiller®



With the „US 1100 TubeChiller“ we offer the fully automatic solution for automatic shrinking and subsequent cooling of tools. The TubeChiller® technology was developed to combine our shrinking devices of the US 1100 series with automatic cooling by the TubeChiller®. After the shrink process, cooling takes place automatically, without the risk for the operator to have contact with hot tools.

The operator places the chuck in the shrink device, pulls the coil down and starts the shrink process. After the shrink process, the cooling tube lifts up from the TubeChiller® housing. At the same time the coolant rises into the cooling tube and flows around the tool like a ring. During this movement, the induction coil is automatically moved back to its starting position without the need for an additional drive or intervention of the operator. After the cooling process, the tool holder is dried with air and ready for use in the machine.

Chiller Unit FKS 04 for fast Cooling, cleaning and preservation

To cool down the tool holders are placed in the tower of the cooling unit and the door is locked. Then the cooling medium is automatically pushed upwards by compressed air from the tank and flows around the previously heated tool in a ring. This ring-shaped and therefore symmetrical flow prevents the tool from „bending“. When all the coolant has arrived in the tower, air flows through the water like in a bubble bath, the water is flushed with room temperature air and always cools down the coolant to room temperature. The tool holder is cleaned, and rust protected at the same time.

All types of shrink holders can be cooled, regardless of their diameter and length.



Diebold / Accutek Horizontal Shrink Unit

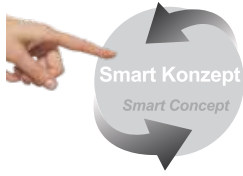

MS 3.0 Horizontal	US 1100 Horizontal
79.336.100	79.500.101



Part Number	Description Options		
79.500.800.101	Basic Display	NA	STD
79.500.800.105	Touch Display	STD	OPT
79.500.800.150	One Touch	NA	OPT
79.500.800.200	Basic Coil	NA	STD
79.500.800.205	Pyrometer Coil	NA	OPT
79.500.800.400	Length Adjustment with indicator	NA	OPT
79.500.800.410	Fixed Stop Length Adjustment	NA	OPT
79.500.800.351	TubeChiller	NA	NA
79.336.210	AirChiller	OPT	OPT
79.402	FKS 04 S Automatic	OPT	OPT

Part Number	Description Options		
79.500.900.001	Tool Holder Basic Adapter for US1100H / MS3.0	REQ	REQ
79.500.900.025	Modular tool holder HSK25	NA	OPT
79.500.900.032	Modular tool holder HSK32	NA	OPT
79.500.900.040	Modular tool holder HSK40	NA	OPT
79.500.900.050	Modular tool holder HSK50	NA	OPT
79.500.900.063	Modular tool holder HSK63	NA	OPT
79.500.900.100	Modular tool holder 30 Taper	NA	OPT
79.500.900.130	Modular tool holder 40 Taper	NA	OPT
79.500.900.150	Modular tool holder 50 Taper	NA	OPT
79.500.900.U	Universal Vise Holder	OPT	OPT

Diebold / Accutek Vertical Shrink Unit

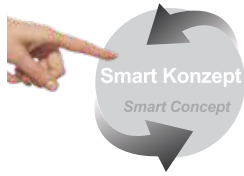

US 1100 Vertical	US 1100 TubeChiller
79.500.201	79.500.201 / 79.500.800.350



Part Number	Description Options		
79.500.800.101	Basic Display	OPT	OPT
79.500.800.105	Touch Display	OPT	OPT
79.500.800.150	One Touch	OPT	OPT
79.500.800.200	Basic Coil	STD	STD
79.500.800.205	Pyrometer Coil	OPT	OPT
79.500.800.400	Length Adjustment with indicator	OPT	OPT
79.500.800.410	Fixed Stop Length Adjustment	OPT	OPT
79.500.800.351	TubeChiller	OPT	STD
79.336.210	AirChiller	OPT	NA
79.402	FKS 04 S Automatic	OPT	NA

Part Number	Description Accessories US 1100 Vertical		
79.220.003	Centering Disc for HSK 100 / 80 / 63	STD	NA
79.220.020	Tool Holder HSK 25 / 32	OPT	OPT
79.220.021	Tool holder HSK 40 / 50	OPT	OPT
79.360.325	Tool holder HSK25 TubeChiller	NA	OPT
79.360.332	Tool holder HSK32 TubeChiller	NA	OPT
79.360.340	Tool holder HSK40 TubeChiller	NA	OPT
79.360.350	Tool holder HSK50 TubeChiller	NA	OPT
79.360.363.01	Tool holder HSK63 TubeChiller	NA	OPT
79.360.380	Tool holder HSK80 TubeChiller	NA	OPT
79.360.390	Tool holder HSK100 TubeChiller	NA	OPT
79.220.011	Tool holder 30 / 40 Taper TubeChiller	OPT	OPT
79.500.900.450	Tool holder 50 Taper TubeChiller	OPT	OPT

Micro Shrink MS 3.0 Unit



Luftkühler AirChiller /
Air cooler AirChiller
79.336.210



Universpanner /
Universal clamps
79.500.900.U



Grundhalter für MS 3.0 /
Basic holder
79.500.900.001

With the Shrink Unit MS 3.0 sensitive, thin-walled shrink chucks are shrunk gently with the right amount of energy to avoid overheating the chucks. Small milling cutters that only have a diameter of 0.04mm to 0.01mm have shank diameter of 3, 4 or 6 mm. This shows another strength of Diebold products. Shrink chucks with a 3 mm bore are not easy to manufacture so that the shrink process works reliably. These milling cutters are very sensitive and may not come into contact with cooling sleeves so that they are not destroyed. Diebold is known for the exceptionally high quality of its products. That is why the best-selling items from the extensive range are shrink chucks with a diameter of 3 mm.

- The MS 3.0 is designed for shrinking of small tool shanks in small holders
- Also, to shrink holders with standard contour up to Ø 16 mm and Shrink Collets TER11-TER20
- Automated shrinking with selectable parameters
- The unit will automatically shut off before overheating the tools
- Even when shrinking mini tools, the holders will not overheat
- For carbide shanks only: Ø 3-16 mm for holders with standard nose configuration Ø 3-16 mm for holders with slim nose design

Part Number	Description Options	Power	Shrink Range	Max. Shrink Length	Power Supply
79.336.100	520 x 350 x 350	3kW	3mm-16mm	328mm GL	230v/60/3 16A

Shrink Unit US 1100H Horizontal Unit



Part Number	Description	Std. / Opt.
79.500.800.101	Basic Control Display	OPT.
79.500.800.105	One Touch Control Display	OPT.
79.500.800.150	Pyrometer Coil System	OPT.
79.402	FKS 04 S Automatic Chiller	OPT.
79.500.900.001	Base Unit	Required
79.500.900.025	HSK 25 A/E	OPT.
79.500.900.032	HSK32 A/E	OPT.
79.500.900.040	HSK40 A/E	OPT.
79.500.900.050	HSK50 A/E	OPT.
79.500.900.063	HSK63 A/E	OPT.
79.500.900.080	HSK80 A/E	OPT.
79.500.900.100	HSK100 A	OPT.
79.500.900.130	30 Taper	OPT.
79.500.900.140	40 Taper	OPT.
79.500.900.150	50 Taper	OPT.
79.500.900.U	Universal / All Tapers	OPT.
79.TER.411	TER11 Collets	OPT.
79.TER.416	TER16 Collets	OPT.
79.TER.420	TER20 Collets	OPT.
79.TER.425	TER25 Collets	OPT.
79.TER.432	TER32 Collets	OPT.
79.500.800.400	Length Adj. with Dial Indicator	OPT.
79.500.800.410	Length Adj. with fixed stop	OPT.

Shrink range Dia. 3mm -32mm / 1/8"-1-1/4" for carbide shanks and 6mm -32mm / 1/4"-1-1/4" HSS shank tools. The optional Pyrometer technology allows automatic and direct temperature control of the Shrink Fit holder during heating. The Shrink Fit holder can no longer over-heat itself. The safe and fast shrink process does not need a prior identification of the Shrink Fit holder.

- Changeable adapters for HSK25-HSK100 or SK/CAT30/BT30 to SK/CAT/BT50 to hold the Shrink Fit tool holders in the shrink position
- With the universal tool clamping adapter, it is possible to clamp all taper sizes centric to shrink coil
- Manual operation with one power button or automatic operation with parameters
- Broken tool removal unit available
- Installation of length setting fixture is possible
- For cool down of the Shrink Fit holders, we recommend using our chiller unit FKS 04 S

Part Number	Dimensions L x T x Hmm	Power	Shrink Range	Max Shrink Length	Power Supply
79.500.101	700x470x387	11 kW	3mm-32mm/ 1/8"-1-1/4"	500mm	480/60/3 16amps



Length Adjustment Fixture with Dial Indicator



TER Collet Holder



FKS 04 S Chiller

Shrink Unit US 1100V Vertical Unit



With the US1100 Vertical the Shrink range Dia. 3mm -32mm / 1/8"-1-1/4" for carbide shanks and 6mm -32mm / 1/4"-1-1/4" HSS shank tools.

The optional Pyrometer technology allows automatic and direct temperature control of the Shrink Fit holder during heating. The Shrink Fit holder can no longer over-heat itself.

Manual operation with parameters or one-button operation means the safe and fast shrink process does not need a prior identification of the Shrink Fit holder.

Part Number	Description	Std. / Opt.
79.500.800.101	Basic Control Display	OPT.
79.500.800.105	One Touch Control Display	OPT.
79.500.800.150	Pyrometer Coil System	OPT.
79.402	FKS 04 S Automatic Chiller	OPT.
79.220.011	FKS 04 S Automatic Chiller	OPT.
79.220.020	SK/BT/CAT 50 Tapers	OPT.
79.220.021	HSK25/32	OPT.
79.220.003	HSK40/50	OPT.
79.TER.100	TER Vert. Adaptor	OPT.
79.TER.111	TER11 Collets	OPT.
79.TER.116	TER16 Collets	OPT.
79.TER.120	TER20 Collets	OPT.
79.TER.125	TER25 Collets	OPT.
79.TER.132	TER32 Collets	OPT.
79.500.800.400	Length Adj. with Dial Indicator	OPT.
79.500.800.410	Length Adj. with fixed stop	OPT.

- HSK63/80/100 shank tools can be inserted directly into the centering disc. For other shank interfaces (SK/BT/CAT 30/40/50 or HSK25 - HSK50) Shrink adapters are available
- Shrinking with Pyrometer & Temp Control
- One Touch push button display offers manual shrink process or automatic with parameters
- For cool down of shrink fit holders, we recommend our FKS 04 S automatic Chiller Unit



Shrink Unit US 1100VTC Vertical with TubeChiller®



- Shrink Unit US 1100V with Tube Chiller®
- Optional pyrometer coil with TempControl for monitoring the shrink temperature
- Foot switch for “hands free” operation i4.0 functions of the devices
- Reading tools data via RFID chip, Data Matrix, or QR code
- Integrated data interfaces USB, RS 242 for network integration
- Data transfer for statistical evaluations and documentation

Part Number	Description	Std. / Opt.
79.500.800.101	Basic Control Display	OPT.
79.500.800.105	One Touch Control Display	OPT.
79.500.800.150	Pyrometer Coil System	OPT.
79.220.011	SK/BT/CAT 30 or 40 Tapers	OPT.
79.220.011	SK/BT/CAT 30 or 40 Tapers	OPT.
79.500.900.450	SK/BT/CAT 50 Tapers	OPT.
79.360.325	HSK25	OPT.
79.360.332	HSK40	OPT.
79.360.350	HSK50	OPT.
79.360.363.01	HSK63	OPT.
79.360.380	HSK80	OPT.
79.360.390	HSK100	OPT.
79.TER.100	TER Vert. Adapter	OPT.
79.TER.111	TER11 Collets	OPT.
79.TER.116	TER16 Collets	OPT.
79.TER.120	TER20 Collets	OPT.
79.TER.125	TER25 Collets	OPT.
79.TER.132	TER32 Collets	OPT.
79.500.800.400	Length Adj. with Dial Indicator	OPT.
79.500.800.410	Length Adj. with fixed stop	OPT.



Delivery includes:

- Shrink Unit US1100 (79.500.201)
- Basic Coil (79.500.800.200) with 5 interchangeable discs, one set of protective gloves
- Optional coil with pyrometer technology (79.500.800.150)
- TubeChiller® (79.500.800.351)
Coolant Additive 1 liter (79.220.001 BL)

Part Number	Des.	Dimensions BxDxHmm	Air Pressure Required	Weight kg	Tank Cap.
79.500.201	US1100 Vertical Unit	470x387x700	-	-	-
79.500.800.351	Tube Chiller	776x556x1580	6 bar	154	19L

Voltage 480/60/3 30 amp



Shrink Fit Unit Accessories



79.402 Automatic FKS 04 Chiller Unit



79.336.210 AirChiller Unit



Length Setting Adapter for US1100V and VTC Units



79.232.063 Broken Tool Removal Fixture



79.220.031 Spiral Hose with Air Gun attachment for FKS 04 Chiller



79.145 Plier Tool for cutting tool exchange



Scanner that reads data matrix - QR code, Bar Code, or Chip information



Data Interface for i4.0 functions, data monitoring and network integration



79.237.10 Length Setting Sleeve

AccuGrip™ Shrink Fit Technology Offering

CAT40 AccuGrip™ Shrink Fit Holders – Standard DIN Length

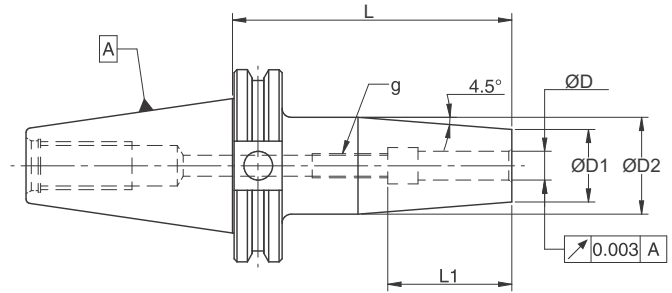

FEATURES

- Balanced to G2.5 @25,000 RPM
- T.I.R. < 0.00012" / 0.003µ
- Taper shank ground to AT3 accuracy (or better)

	Catalog Number	Description	ØD	L	ØD1	ØD2	L1	g	Coolant Style
CAT40 Inch	94240719	CAT40-SF 0.125-3.74	0.125	3.74	0.39	0.71	0.35	-	AD Thru
	94240919	CAT40-SF 0.187-3.74	0.187	3.74	0.39	0.71	0.47	-	AD Thru
	94241119	CAT40-SF 0.250-3.74	0.250	3.74	0.83	1.06	1.42	M5	AD Thru
	94241319	CAT40-SF 0.312-3.74	0.312	3.74	0.83	1.06	1.42	M5	AD Thru
	94242619	CAT40-SF 0.375-3.74	0.375	3.74	0.95	1.26	1.65	M8X1	AD Thru
	94241519	CAT40-SF 0.500-3.74	0.500	3.74	1.06	1.34	1.85	M10X1	AD Thru
	94241719	CAT40-SF 0.625-3.74	0.625	3.74	1.06	1.34	1.97	M12X1	AD Thru
	94242819	CAT40-SF 0.750-3.74	0.750	3.74	1.30	1.65	2.05	M16X1	AD Thru
	94242120	CAT40-SF 1.000-3.94	1.000	3.94	1.73	2.09	2.44	M16X1	AD Thru
	94242220	CAT40-SF 1.250-3.94	1.250	3.94	1.73	2.09	2.44	M16X1	AD Thru
CAT40 Metric	94240319	CAT40-SF 3-95	3	95	10	18	9	-	AD Thru
	94240419	CAT40-SF 4-95	4	95	10	18	12	-	AD Thru
	94240519	CAT40-SF 5-95	5	95	10	18	15	-	AD Thru
	94240619	CAT40-SF 6-95	6	95	21	27	36	M5	AD Thru
	94240819	CAT40-SF 8-95	8	95	21	27	36	M6	AD Thru
	94241019	CAT40-SF 10-95	10	95	24	32	42	M8X1	AD Thru
	94241219	CAT40-SF 12-95	12	95	24	32	47	M10X1	AD Thru
	94241419	CAT40-SF 14-95	14	95	27	34	47	M10X1	AD Thru
	94241619	CAT40-SF 16-95	16	95	27	34	50	M12X1	AD Thru
	94241819	CAT40-SF 18-95	18	95	33	42	50	M12X1	AD Thru
	94242019	CAT40-SF 20-95	20	95	33	42	52	M16X1	AD Thru
	94242520	CAT40-SF 25-100	25	100	44	53	58	M16X1	AD Thru
	94243220	CAT40-SF 32-100	32	100	44	53	62	M16X1	AD Thru

NOTE:

AccuGrip™ is available with AccuKool™ ports.

To request make the following changes to part no. and descriptions :

Example : 94241519 becomes 94241519-3CP.

The description goes from CAT40-SF .500-3.74 to CAT40-SF-IK3 .500-3.74.

Retention knobs **on page 198-199**

AccuGrip™ Shrink Fit Technology Offering

CAT40 AccuGrip™ Shrink Fit Holders – Long DIN Length

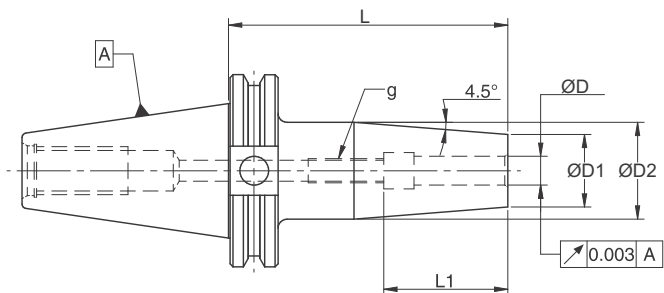

FEATURES

- Balanced to G2.5 @25,000 RPM
- T.I.R. < 0.00012" / 0.003μ
- Taper shank ground to AT3 accuracy (or better)

	Catalog Number	Description	ØD	L	ØD1	ØD2	L1	g	Coolant Style
CAT40 Inch	94240724	CAT40-SF 0.125-4.72	0.125	4.72	0.39	0.71	0.35	-	AD Thru
	94240924	CAT40-SF 0.187-4.72	0.187	4.72	0.39	0.71	0.47	-	AD Thru
	94241124	CAT40-SF 0.250-4.72	0.250	4.72	0.83	1.06	1.42	M5	AD Thru
	94241324	CAT40-SF 0.312-4.72	0.312	4.72	0.83	1.06	1.42	M5	AD Thru
	94242624	CAT40-SF 0.375-4.72	0.375	4.72	0.95	1.26	1.65	M8X1	AD Thru
	94241524	CAT40-SF 0.500-4.72	0.500	4.72	1.06	1.34	1.85	M10X1	AD Thru
	94241724	CAT40-SF 0.625-4.72	0.625	4.72	1.06	1.34	1.97	M12X1	AD Thru
	94242824	CAT40-SF 0.750-4.72	0.750	4.72	1.30	1.65	2.05	M16X1	AD Thru
	94242124	CAT40-SF 1.000-4.72	1.000	4.72	1.73	2.09	2.44	M16X1	AD Thru
	94242224	CAT40-SF 1.250-4.72	1.250	4.72	1.73	2.09	2.44	M16X1	AD Thru
CAT40 Metric	94240324	CAT40-SF 3-120	3	120	10	18	9	-	AD Thru
	94240424	CAT40-SF 4-120	4	120	10	18	12	-	AD Thru
	94240524	CAT40-SF 5-120	5	120	10	18	15	-	AD Thru
	94240624	CAT40-SF 6-120	6	120	21	27	36	M5	AD Thru
	94240824	CAT40-SF 8-120	8	120	21	27	36	M6	AD Thru
	94241024	CAT40-SF 10-120	10	120	24	32	42	M8X1	AD Thru
	94241224	CAT40-SF 12-120	12	120	24	32	47	M10X1	AD Thru
	94241424	CAT40-SF 14-120	14	120	27	34	47	M10X1	AD Thru
	94241624	CAT40-SF 16-120	16	120	27	34	50	M12X1	AD Thru
	94241824	CAT40-SF 18-120	18	120	33	42	50	M12X1	AD Thru
	94242024	CAT40-SF 20-120	20	120	33	42	52	M16X1	AD Thru
	94242524	CAT40-SF 25-120	25	120	44	53	58	M16X1	AD Thru
	94243224	CAT40-SF 32-120	32	120	44	53	62	M16X1	AD Thru

NOTE:

AccuGrip™ is available with AccuKool™ ports.

To request make the following changes to part no. and descriptions :

Example : 94241724 becomes 94241724-3CP.

The description goes from CAT40-SF .625-4.72 to CAT40-SF-IK3 .625-4.72

Retention knobs **on page 198-199**

AccuGrip™ Shrink Fit Technology Offering

CAT40 AccuGrip™ Shrink Fit Holders – X-Long DIN Length

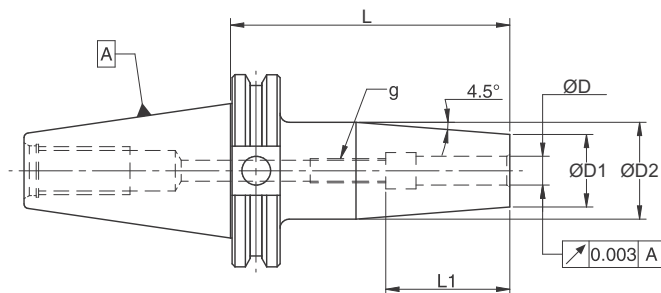

FEATURES

- Balanced to G2.5 @25,000 RPM
- Taper shank ground to AT3 accuracy (or better)
- T.I.R. < 0.00012" / 0.003µ

	Catalog Number	Description	ØD	L	ØD1	ØD2	L1	g	Coolant Style
CAT40 Inch	94240732	CAT40-SF 0.125-6.30	0.125	6.30	0.39	0.71	0.35	-	AD Thru
	94240932	CAT40-SF 0.187-6.30	0.187	6.30	0.39	0.71	0.47	-	AD Thru
	94241132	CAT40-SF 0.250-6.30	0.250	6.30	0.83	1.06	1.42	M5	AD Thru
	94241332	CAT40-SF 0.312-6.30	0.312	6.30	0.83	1.06	1.42	M5	AD Thru
	94242632	CAT40-SF 0.375-6.30	0.375	6.30	0.95	1.26	1.65	M8X1	AD Thru
	94241532	CAT40-SF 0.500-6.30	0.500	6.30	1.06	1.34	1.85	M10X1	AD Thru
	94241732	CAT40-SF 0.625-6.30	0.625	6.30	1.06	1.34	1.97	M12X1	AD Thru
	94242832	CAT40-SF 0.750-6.30	0.750	6.30	1.30	1.65	2.05	M16X1	AD Thru
	94242132	CAT40-SF 1.000-6.30	1.000	6.30	1.73	2.09	2.44	M16X1	AD Thru
	94242232	CAT40-SF 1.250-6.30	1.250	6.30	1.73	2.09	2.44	M16X1	AD Thru
CAT40 Metric	94240332	CAT40-SF 3-160	3	160	10	18	9	-	AD Thru
	94240432	CAT40-SF 4-160	4	160	10	18	12	-	AD Thru
	94240532	CAT40-SF 5-160	5	160	10	18	15	-	AD Thru
	94240632	CAT40-SF 6-160	6	160	21	27	36	M5	AD Thru
	94240832	CAT40-SF 8-160	8	160	21	27	36	M6	AD Thru
	94241032	CAT40-SF 10-160	10	160	24	32	42	M8X1	AD Thru
	94241232	CAT40-SF 12-160	12	160	24	32	47	M10X1	AD Thru
	94241432	CAT40-SF 14-160	14	160	27	34	47	M10X1	AD Thru
	94241632	CAT40-SF 16-160	16	160	27	34	50	M12X1	AD Thru
	94241832	CAT40-SF 18-160	18	160	33	42	50	M12X1	AD Thru
	94242032	CAT40-SF 20-160	20	160	33	42	52	M16X1	AD Thru
	94242532	CAT40-SF 25-160	25	160	44	53	58	M16X1	AD Thru
	94243232	CAT40-SF 32-160	32	160	44	53	62	M16X1	AD Thru

NOTE:

AccuGrip™ is available with AccuKool™ ports.

To request make the following changes to part no. and descriptions :

Example : 94241732 becomes 94241732-3CP.

The description goes from CAT40-SF .625-6.30 to CAT40-SF-IK3 .625-6.30.

Retention knobs **on page 198-199**

AccuGrip™ Shrink Fit Technology Offering

CAT50 AccuGrip™ Shrink Fit Holders – Standard DIN Length

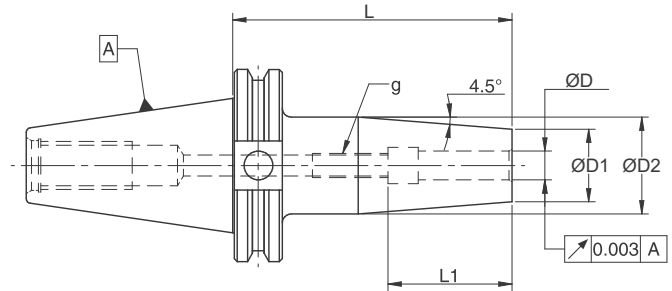

FEATURES

- Balanced to G2.5 @25,000 RPM
- T.I.R. < 0.00012" / 0.003µ
- Taper shank ground to AT3 accuracy (or better)

	Catalog Number	Description	ØD	L	ØD1	ØD2	L1	g	Coolant Style
CAT50 Inch	94261119	CAT50-SF 0.250-3.74	0.250	3.74	0.83	1.06	1.42	M5	AD Thru
	94262619	CAT50-SF 0.375-3.74	0.375	3.74	0.95	1.26	1.65	M8X1	AD Thru
	94261519	CAT50-SF 0.500-3.74	0.500	3.74	1.06	1.34	1.85	M10X1	AD Thru
	94261719	CAT50-SF 0.625-3.74	0.625	3.74	1.06	1.34	1.97	M12X1	AD Thru
	94262819	CAT50-SF 0.750-3.74	0.750	3.74	1.30	1.65	2.05	M16X1	AD Thru
	94262121	CAT50-SF 1.000-4.13	1.000	4.13	1.73	2.09	2.28	M16X1	AD Thru
	94262221	CAT50-SF 1.250-4.13	1.250	4.13	1.73	2.09	2.44	M16X1	AD Thru
CAT50 Metric	94260619	CAT50-SF 6-95	6	95	21	27	36	M5	AD Thru
	94260819	CAT50-SF 8-95	8	95	21	27	36	M6	AD Thru
	94261019	CAT50-SF 10-95	10	95	24	32	42	M8X1	AD Thru
	94261219	CAT50-SF 12-95	12	95	24	32	47	M10X1	AD Thru
	94261419	CAT50-SF 14-95	14	95	27	34	47	M10X1	AD Thru
	94261619	CAT50-SF 16-95	16	95	27	34	50	M12X1	AD Thru
	94261819	CAT50-SF 18-95	18	95	33	42	50	M12X1	AD Thru
	94262019	CAT50-SF 20-95	20	95	33	42	52	M16X1	AD Thru
	94262521	CAT50-SF 25-105	25	105	44	53	58	M16X1	AD Thru
	94263221	CAT50-SF 32-105	32	105	44	53	62	M16X1	AD Thru

NOTE:

AccuGrip™ is available with AccuKool™ ports.
 To request make the following changes to part no. and descriptions :
 Example : 94261719 becomes 94261719-3CP.
 The description goes from CAT50-SF .625-3.74 to CAT50-SF-**IK3** .625-3.74
 Retention knobs **on page 198-199**

AccuGrip™ Shrink Fit Technology Offering

CAT50 AccuGrip™ Shrink Fit Holders – Long DIN Length

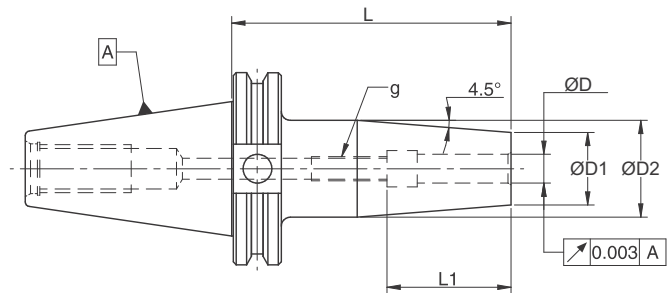

FEATURES

- Balanced to G2.5 @25,000 RPM
- T.I.R. < 0.00012" / 0.003μ
- Taper shank ground to AT3 accuracy (or better)

	Catalog Number	Description	ØD1	L	ØD1	ØD2	L1	g	Coolant Style
CAT50 Inch	94261124	CAT50-SF 0.250-4.72	0.250	4.72	0.83	1.06	1.42	M5	AD Thru
	94262624	CAT50-SF 0.375-4.72	0.375	4.72	0.95	1.26	1.65	M8X1	AD Thru
	94261524	CAT50-SF 0.500-4.72	0.500	4.72	1.06	1.34	1.85	M10X1	AD Thru
	94261724	CAT50-SF 0.625-4.72	0.625	4.72	1.06	1.34	1.97	M12X1	AD Thru
	94262824	CAT50-SF 0.750-4.72	0.750	4.72	1.30	1.65	2.05	M16X1	AD Thru
	94262124	CAT50-SF 1.000-4.72	1.000	4.72	1.73	2.09	2.28	M16X1	AD Thru
	94262224	CAT50-SF 1.250-4.72	1.250	4.72	1.73	2.09	2.44	M16X1	AD Thru
CAT50 Metric	94260624	CAT50-SF 6-120	6	120	21	27	36	M5	AD Thru
	94260824	CAT50-SF 8-120	8	120	21	27	36	M6	AD Thru
	94261024	CAT50-SF 10-120	10	120	24	32	42	M8X1	AD Thru
	94261224	CAT50-SF 12-120	12	120	24	32	47	M10X1	AD Thru
	94261424	CAT50-SF 14-120	14	120	27	34	47	M10X1	AD Thru
	94261624	CAT50-SF 16-120	16	120	27	34	50	M12X1	AD Thru
	94261824	CAT50-SF 18-120	18	120	33	42	50	M12X1	AD Thru
	94262024	CAT50-SF 20-120	20	120	33	42	52	M16X1	AD Thru
	94262524	CAT50-SF 25-120	25	120	44	53	58	M16X1	AD Thru
	94263224	CAT50-SF 32-120	32	120	44	53	62	M16X1	AD Thru

NOTE:

AccuGrip™ is available with AccuKool™ ports.

To request make the following changes to part no. and descriptions :

Example : 94261724 becomes 94261724-3CP.

The description goes from CAT50-SF .625-4.72 to CAT50-SF-IK3 .625-4.72.

Retention knobs **on page 198-199**

AccuGrip™ Shrink Fit Technology Offering

CAT50 AccuGrip™ Shrink Fit Holders – X-Long DIN Length

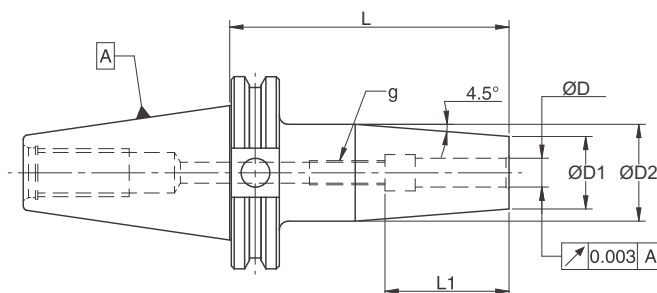

FEATURES

- Balanced to G2.5 @25,000 RPM
- T.I.R. < 0.00012" / 0.003µ
- Taper shank ground to AT3 accuracy (or better)

	Catalog Number	Description	ØD1	L	ØD1	ØD2	L1	g	Coolant Style
CAT50 Inch	94261132	CAT50-SF 0.250-6.30	0.250	6.30	0.83	1.06	1.42	M5	AD Thru
	94262632	CAT50-SF 0.375-6.30	0.375	6.30	0.95	1.26	1.65	M8X1	AD Thru
	94261532	CAT50-SF 0.500-6.30	0.500	6.30	1.06	1.34	1.85	M10X1	AD Thru
	94261732	CAT50-SF 0.625-6.30	0.625	6.30	1.06	1.34	1.97	M12X1	AD Thru
	94262832	CAT50-SF 0.750-6.30	0.750	6.30	1.30	1.65	2.05	M16X1	AD Thru
	94262132	CAT50-SF 1.000-6.30	1.000	6.30	1.73	2.09	2.28	M16X1	AD Thru
	94262232	CAT50-SF 1.250-6.30	1.250	6.30	1.73	2.09	2.44	M16X1	AD Thru
CAT50 Metric	94260632	CAT50-SF 6-160	6	160	21	27	36	M5	AD Thru
	94260832	CAT50-SF 8-160	8	160	21	27	36	M6	AD Thru
	94261032	CAT50-SF 10-160	10	160	24	32	42	M8X1	AD Thru
	94261232	CAT50-SF 12-160	12	160	24	32	47	M10X1	AD Thru
	94261432	CAT50-SF 14-160	14	160	27	34	47	M10X1	AD Thru
	94261632	CAT50-SF 16-160	16	160	27	34	50	M12X1	AD Thru
	94261832	CAT50-SF 18-160	18	160	33	42	50	M12X1	AD Thru
	94262032	CAT50-SF 20-160	20	160	33	42	52	M16X1	AD Thru
	94262532	CAT50-SF 25-160	25	160	44	53	58	M16X1	AD Thru
	94263232	CAT50-SF 32-160	32	160	44	53	62	M16X1	AD Thru

NOTE:

AccuGrip™ is available with AccuKool™ ports.
 To request make the following changes to part no. and descriptions :
 Example : 94261732 becomes 94261732-3CP.
 The description goes from CAT50-SF .625-6.30 to CAT50-SF-1K3 .625-6.30.
 Retention knobs on page 198-199

AccuGrip™ Shrink Fit Technology Offering

BT30 AccuGrip™ Shrink Fit Holders – Standard DIN Length

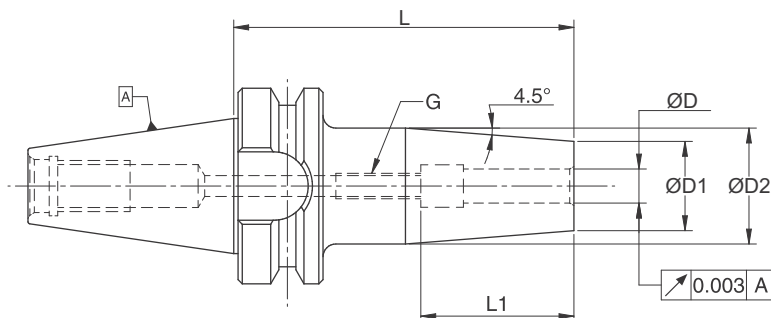

FEATURES

- Balanced to G2.5 @25,000 RPM
- T.I.R. < 0.00012" / 0.003μ
- Taper shank ground to AT3 accuracy (or better)

	Catalog Number	Description	ØD	L	ØD1	ØD2	L1	g	Coolant Style
BT30 Inch	94100716	BT30-SF 0.125-3.15	0.125	3.15	0.39	0.71	0.35	-	AD Thru
	94100916	BT30-SF 0.187-3.15	0.187	3.15	0.39	0.71	0.47	-	AD Thru
	94101116	BT30-SF 0.250-3.15	0.250	3.15	0.83	1.06	1.42	M5	AD Thru
	94102616	BT30-SF 0.375-3.15	0.375	3.15	0.95	1.26	1.65	M8X1	AD Thru
	94101516	BT30-SF 0.500-3.15	0.500	3.15	0.95	1.26	1.85	M10X1	AD Thru
	94101716	BT30-SF 0.625-3.15	0.625	3.15	1.06	1.34	1.97	M12X1	AD Thru
BT30 Metric	94100316	BT30-SF 3-80	3	80	10	18	9	-	AD Thru
	94100416	BT30-SF 4-80	4	80	10	18	12	-	AD Thru
	94100516	BT30-SF 5-80	5	80	10	18	15	-	AD Thru
	94100616	BT30-SF 6-80	6	80	21	27	36	M5	AD Thru
	94100816	BT30-SF 8-80	8	80	21	27	36	M6	AD Thru
	94101016	BT30-SF 10-80	10	80	24	32	42	M8X1	AD Thru
	94101216	BT30-SF 12-80	12	80	24	32	47	M10X1	AD Thru
	94101616	BT30-SF 16-80	16	80	27	34	50	M12X1	AD Thru
	94102016	BT30-SF 20-80	20	80	33	42	52	M16X1	AD Thru

NOTE:

AccuGrip™ is available with AccuKool™ ports.

To request make the following changes to part no. and descriptions :

Example : 94101716 becomes 94101716-3CP.

The description goes from BT30-SF .625-3.15 to BT30-SF-IK3 .625-3.15.

Retention knobs **on page 198-199**

AccuGrip™ Shrink Fit Technology Offering

BT40 AccuGrip™ Shrink Fit Holders – Standard DIN Length

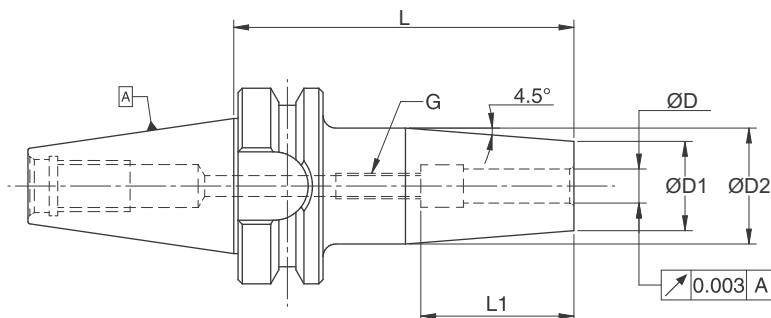

FEATURES

- Balanced to G2.5 @25,000 RPM
- T.I.R. < 0.00012" / 0.003μ
- Taper shank ground to AT3 accuracy (or better)

	Catalog Number	Description	ØD	L	ØD1	ØD2	L1	g	Coolant Style
BT40 Inch	94120718	BT40-SF 0.125-3.54	0.125	3.54	0.39	0.71	0.35	-	AD Thru
	94120918	BT40-SF 0.187-3.54	0.187	3.54	0.39	0.71	0.47	-	AD Thru
	94121118	BT40-SF 0.250-3.54	0.250	3.54	0.83	1.06	1.42	M5	AD Thru
	94122618	BT40-SF 0.375-3.54	0.375	3.54	0.95	1.26	1.65	M8X1	AD Thru
	94121518	BT40-SF 0.500-3.54	0.500	3.54	1.06	1.34	1.85	M10X1	AD Thru
	94121718	BT40-SF 0.625-3.54	0.625	3.54	1.06	1.34	1.97	M12X1	AD Thru
	94122818	BT40-SF 0.750-3.54	0.750	3.54	1.30	1.65	2.05	M16X1	AD Thru
	94122120	BT40-SF 1.000-3.94	1.000	3.94	1.73	2.09	2.44	M16X1	AD Thru
	94122220	BT40-SF 1.250-3.94	1.250	3.94	1.73	2.09	2.44	M16X1	AD Thru
BT40 Metric	94120318	BT40-SF 3-90	3	90	10	18	9	-	AD Thru
	94120418	BT40-SF 4-90	4	90	10	18	12	-	AD Thru
	94120518	BT40-SF 5-90	5	90	10	18	15	-	AD Thru
	94120618	BT40-SF 6-90	6	90	21	27	36	M5	AD Thru
	94120818	BT40-SF 8-90	8	90	21	27	36	M6	AD Thru
	94121018	BT40-SF 10-90	10	90	24	32	42	M8X1	AD Thru
	94121218	BT40-SF 12-90	12	90	24	32	47	M10X1	AD Thru
	94121618	BT40-SF 16-90	16	90	27	34	50	M12X1	AD Thru
	94122018	BT40-SF 20-90	20	90	33	42	52	M16X1	AD Thru
	94122520	BT40-SF 25-100	25	100	44	53	58	M16X1	AD Thru
	94123220	BT40-SF 32-100	32	100	44	53	58	M16X1	AD Thru

NOTE:

AccuGrip™ is available with AccuKool™ ports.
 To request make the following changes to part no. and descriptions :
 Example : 94121718 becomes 94121718-3CP.
 The description goes from BT40-SF .625-3.54 to BT40-SF-1K3 .625-3.54.
 Retention knobs on page 198-199

AccuGrip™ Shrink Fit Technology Offering

BT40 AccuGrip™ Shrink Fit Holders – Long DIN Length

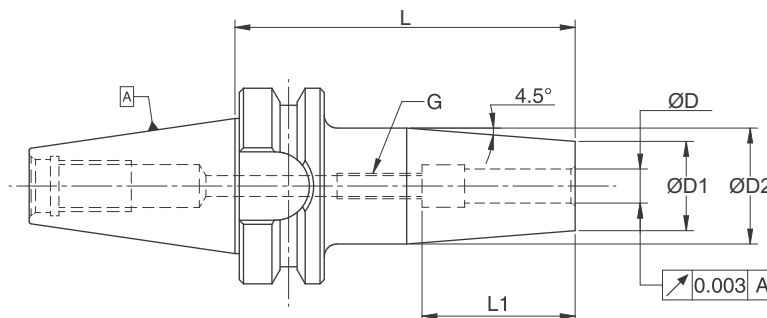

FEATURES

- Balanced to G2.5 @25,000 RPM
- T.I.R. < 0.00012" / 0.003µ
- Taper shank ground to AT3 accuracy (or better)

	Catalog Number	Description	ØD	L	ØD1	ØD2	L1	g	Coolant Style
BT40 Inch	94120724	BT40-SF 0.125-4.72	0.125	4.72	0.39	0.71	0.35	-	AD Thru
	94120924	BT40-SF 0.187-4.72	0.187	4.72	0.39	0.71	0.47	-	AD Thru
	94121124	BT40-SF 0.250-4.72	0.250	4.72	0.83	1.06	1.42	M5	AD Thru
	94122624	BT40-SF 0.375-4.72	0.375	4.72	0.95	1.26	1.65	M8X1	AD Thru
	94121524	BT40-SF 0.500-4.72	0.500	4.72	1.06	1.34	1.85	M10X1	AD Thru
	94121724	BT40-SF 0.625-4.72	0.625	4.72	1.06	1.34	1.97	M12X1	AD Thru
	94122824	BT40-SF 0.750-4.72	0.750	4.72	1.30	1.65	2.05	M16X1	AD Thru
	94122124	BT40-SF 1.000-4.72	1.000	4.72	1.73	2.09	2.44	M16X1	AD Thru
	94122224	BT40-SF 1.250-4.72	1.250	4.72	1.73	2.09	2.44	M16X1	AD Thru
BT40 Metric	94120324	BT40-SF 3-120	3	120	10	18	9	-	AD Thru
	94120424	BT40-SF 4-120	4	120	10	18	12	-	AD Thru
	94120524	BT40-SF 5-120	5	120	10	18	15	-	AD Thru
	94120624	BT40-SF 6-120	6	120	21	27	36	M5	AD Thru
	94120824	BT40-SF 8-120	8	120	21	27	36	M6	AD Thru
	94121024	BT40-SF 10-120	10	120	24	34	42	M8X1	AD Thru
	94121224	BT40-SF 12-120	12	120	24	34	47	M10X1	AD Thru
	94121624	BT40-SF 16-120	16	120	27	37	50	M12X1	AD Thru
	94122024	BT40-SF 20-120	20	120	33	43	52	M16X1	AD Thru
	94122524	BT40-SF 25-120	25	120	44	53	58	M16X1	AD Thru
	94123224	BT40-SF 32-120	32	120	44	53	58	M16X1	AD Thru

NOTE:

AccuGrip™ is available with AccuKool™ ports.

To request make the following changes to part no. and descriptions :

Example : 94121724 becomes 94121724-3CP.

The description goes from BT40-SF .625-4.72 to BT40-SF-IK3 .625-4.72.

Retention knobs **on page 198-199**

AccuGrip™ Shrink Fit Technology Offering

BT40 AccuGrip™ Shrink Fit Holders – X-Long DIN Length

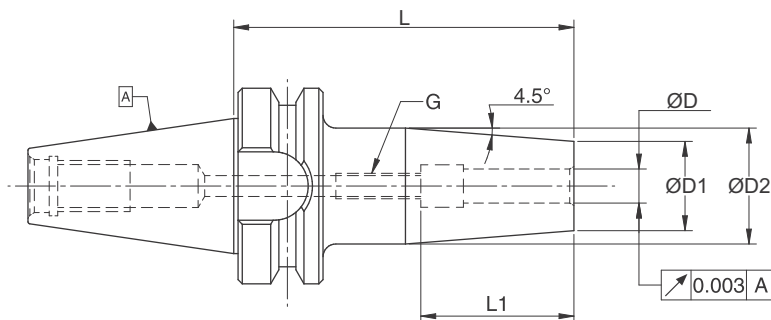

FEATURES

- Balanced to G2.5 @25,000 RPM
- T.I.R. < 0.00012" / 0.003μ
- Taper shank ground to AT3 accuracy (or better)

	Catalog Number	Description	ØD	L	ØD1	ØD2	L1	g	Coolant Style
BT40 Inch	94120732	BT40-SF 0.125-6.30	0.125	6.30	0.39	0.71	0.35	-	AD Thru
	94120932	BT40-SF 0.187-6.30	0.187	6.30	0.39	0.71	0.47	-	AD Thru
	94121132	BT40-SF 0.250-6.30	0.250	6.30	0.83	1.06	1.42	M5	AD Thru
	94122632	BT40-SF 0.375-6.30	0.375	6.30	0.95	1.26	1.65	M8X1	AD Thru
	94121532	BT40-SF 0.500-6.30	0.500	6.30	1.06	1.34	1.85	M10X1	AD Thru
	94121732	BT40-SF 0.625-6.30	0.625	6.30	1.06	1.34	1.97	M12X1	AD Thru
	94122832	BT40-SF 0.750-6.30	0.750	6.30	1.30	1.65	2.05	M16X1	AD Thru
	94122132	BT40-SF 1.000-6.30	1.000	6.30	1.73	2.09	2.44	M16X1	AD Thru
	94122232	BT40-SF 1.250-6.30	1.250	6.30	1.73	2.09	2.44	M16X1	AD Thru
BT40 Metric	94120332	BT40-SF 3-160	3	160	10	18	9	-	AD Thru
	94120432	BT40-SF 4-160	4	160	10	18	12	-	AD Thru
	94120532	BT40-SF 5-160	5	160	10	18	15	-	AD Thru
	94120632	BT40-SF 6-160	6	160	21	27	36	M5	AD Thru
	94120832	BT40-SF 8-160	8	160	21	27	36	M6	AD Thru
	94121032	BT40-SF 10-160	10	160	24	34	42	M8X1	AD Thru
	94121232	BT40-SF 12-160	12	160	24	34	47	M10X1	AD Thru
	94121632	BT40-SF 16-160	16	160	27	37	50	M12X1	AD Thru
	94122032	BT40-SF 20-160	20	160	33	43	52	M16X1	AD Thru
	94122532	BT40-SF 25-160	25	160	44	53	58	M16X1	AD Thru
	94123232	BT40-SF 32-160	32	160	44	53	58	M16X1	AD Thru

NOTE:

AccuGrip™ is available with AccuKool™ ports.
 To request make the following changes to part no. and descriptions :
 Example : 94121732 becomes 94121732-3CP.
 The description goes from BT40-SF .625-6.30 to BT40-SF-3CP .625-6.30.
 Retention knobs **on page 198-199**

AccuGrip™ Shrink Fit Technology Offering

HSK63A AccuGrip™ Shrink Fit Holders – Standard DIN Length

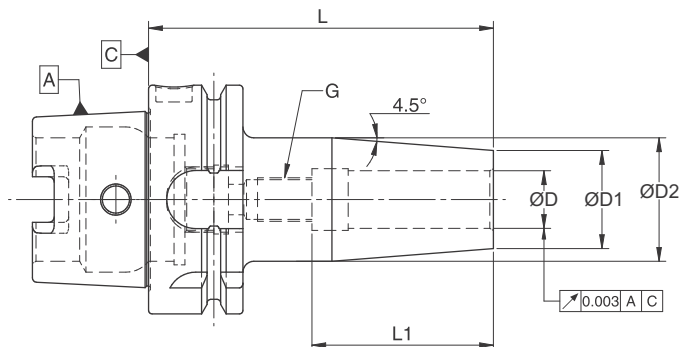

FEATURES

- Balanced to G2.5 @25,000 RPM
- T.I.R. < 0.00012" / 0.003µ

	Catalog Number	Description	ØD	L	ØD1	ØD2	L1	g	Coolant Style
HSK63A Inch	9474A0716	HSK-63A-SF 0.125-3.15	0.125	3.15	0.39	0.71	0.35	-	AD Thru
	9474A0916	HSK-63A-SF 0.187-3.15	0.187	3.15	0.39	0.71	0.47	-	AD Thru
	9474A1116	HSK-63A-SF 0.250-3.15	0.250	3.15	0.83	1.06	1.42	M5	AD Thru
	9474A2617	HSK-63A-SF 0.375-3.34	0.375	3.34	0.95	1.26	1.65	M8X1	AD Thru
	9474A1518	HSK-63A-SF 0.500-3.54	0.500	3.54	1.06	1.34	1.85	M10X1	AD Thru
	9474A1719	HSK-63A-SF 0.625-3.74	0.625	3.74	1.06	1.34	1.97	M12X1	AD Thru
	9474A2820	HSK-63A-SF 0.750-3.94	0.750	3.94	1.30	1.65	2.05	M16X1	AD Thru
	9474A2124	HSK-63A-SF 1.000-4.72	1.000	4.72	1.73	2.09	2.44	M16X1	AD Thru
9474A2224	HSK-63A-SF 1.250-4.72	1.250	4.72	1.73	2.09	2.28	M16X1	AD Thru	
HSK63A Metric	9474A0316	HSK-63A-SF 3-80	3	80	10	18	9	-	AD Thru
	9474A0416	HSK-63A-SF 4-80	4	80	10	18	12	-	AD Thru
	9474A0516	HSK-63A-SF 5-80	5	80	10	18	15	-	AD Thru
	9474A0616	HSK-63A-SF 6-80	6	80	21	27	36	M5	AD Thru
	9474A0816	HSK-63A-SF 8-80	8	80	21	27	36	M6	AD Thru
	9474A1017	HSK-63A-SF 10-85	10	85	24	32	42	M8X1	AD Thru
	9474A1218	HSK-63A-SF 12-90	12	90	24	32	47	M10X1	AD Thru
	9474A1418	HSK-63A-SF 14-90	14	90	27	34	47	M10X1	AD Thru
	9474A1618	HSK-63A-SF 16-90	16	90	27	34	50	M12X1	AD Thru
	9474A1819	HSK-63A-SF 18-95	18	95	33	42	50	M12X1	AD Thru
	9474A2020	HSK-63A-SF 20-100	20	100	33	42	52	M16X1	AD Thru

NOTE:

AccuGrip™ is available with AccuKool™ ports.

To request make the following changes to part no. and descriptions :

Example : 9474A1719 becomes 9474A1719-3CP.

The description goes from HSK-63A-SF 0.625-3.74 to HSK-63A-SF-3CP .625-3.74.

Coolant tubes **on page 200**

Coolant Tube Wrenches **on page 204**

AccuGrip™ Shrink Fit Technology Offering

HSK63A AccuGrip™ Shrink Fit Holders – Long DIN Length

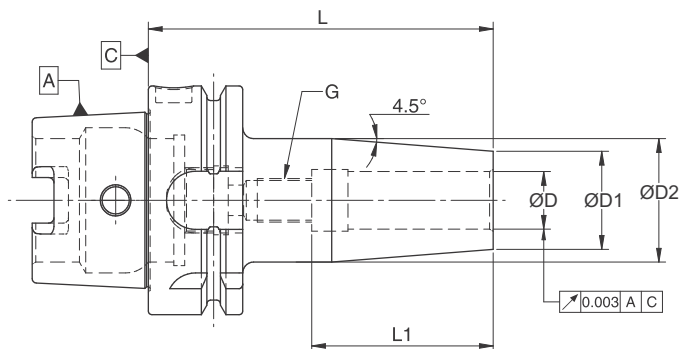

FEATURES

- Balanced to G2.5 @25,000 RPM
- T.I.R. < 0.00012" / 0.003μ

	Catalog Number	Description	ØD	L	ØD1	ØD2	L1	g	Coolant Style
HSK63A Inch	9474A0724	HSK-63A-SF 0.125-4.72	0.125	4.72	0.39	0.71	0.35	-	AD Thru
	9474A0924	HSK-63A-SF 0.187-4.72	0.187	4.72	0.39	0.71	0.47	-	AD Thru
	9474A1124	HSK-63A-SF 0.250-4.72	0.250	4.72	0.83	1.06	1.42	M5	AD Thru
	9474A2624	HSK-63A-SF 0.375-4.72	0.375	4.72	0.95	1.26	1.65	M8X1	AD Thru
	9474A1524	HSK-63A-SF 0.500-4.72	0.500	4.72	1.06	1.34	1.85	M10X1	AD Thru
	9474A1724	HSK-63A-SF 0.625-4.72	0.625	4.72	1.06	1.34	1.97	M12X1	AD Thru
	9474A2824	HSK-63A-SF 0.750-4.72	0.750	4.72	1.30	1.65	2.05	M16X1	AD Thru
	9474A2124	HSK-63A-SF 1.000-4.72	1.000	4.72	1.73	2.09	2.44	M16X1	AD Thru
	9474A2224	HSK-63A-SF 1.250-4.72	1.250	4.72	1.73	2.09	2.28	M16X1	AD Thru
HSK63A Metric	9474A0324	HSK-63A-SF 3-120	3	120	10	18	9	-	AD Thru
	9474A0424	HSK-63A-SF 4-120	4	120	10	18	12	-	AD Thru
	9474A0524	HSK-63A-SF 5-120	5	120	10	18	15	-	AD Thru
	9474A0624	HSK-63A-SF 6-120	6	120	21	27	36	M5	AD Thru
	9474A0824	HSK-63A-SF 8-120	8	120	21	27	36	M6	AD Thru
	9474A1024	HSK-63A-SF 10-120	10	120	24	32	42	M8X1	AD Thru
	9474A1224	HSK-63A-SF 12-120	12	120	24	32	47	M10X1	AD Thru
	9474A1424	HSK-63A-SF 14-120	14	120	27	34	47	M10X1	AD Thru
	9474A1624	HSK-63A-SF 16-120	16	120	27	34	50	M12X1	AD Thru
	9474A1824	HSK-63A-SF 18-120	18	120	33	42	50	M12X1	AD Thru
	9474A2024	HSK-63A-SF 20-120	20	120	33	42	52	M16X1	AD Thru
	9474A2524	HSK-63A-SF 25-120	25	120	44	53	58	M16X1	AD Thru
	9474A3224	HSK-63A-SF 32-120	32	120	44	53	62	M16X1	AD Thru

NOTE:

AccuGrip™ is available with AccuKool™ ports.

To request make the following changes to part no. and descriptions :

Example : 9474A1724 becomes 9474A1724-3CP.

The description goes from HSK-63A-SF .625-4.72 to HSK-63A-SF-3CP .625-4.72.

Coolant tubes **on page 200**

Coolant Tube Wrenches **on page 204**

AccuGrip™ Shrink Fit Technology Offering

HSK63A AccuGrip™ Shrink Fit Holders - X-Long DIN Length

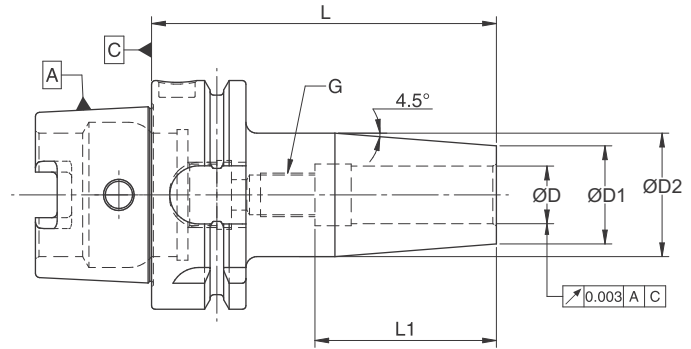

FEATURES

- Balanced to G2.5 @25,000 RPM
- T.I.R. < 0.00012" / 0.003μ

	Catalog Number	Description	ØD	L	ØD1	ØD2	L1	g	Coolant Style
HSK63A Inch	9474A0732	HSK-63A-SF 0.125-6.30	0.125	6.30	0.39	0.71	0.35	-	AD Thru
	9474A0932	HSK-63A-SF 0.187-6.30	0.187	6.30	0.39	0.71	0.47	-	AD Thru
	9474A1132	HSK-63A-SF 0.250-6.30	0.250	6.30	0.83	1.06	1.42	M5	AD Thru
	9474A2632	HSK-63A-SF 0.375-6.30	0.375	6.30	0.95	1.26	1.65	M8X1	AD Thru
	9474A1532	HSK-63A-SF 0.500-6.30	0.500	6.30	1.06	1.34	1.85	M10X1	AD Thru
	9474A1732	HSK-63A-SF 0.625-6.30	0.625	6.30	1.06	1.34	1.97	M12X1	AD Thru
	9474A2832	HSK-63A-SF 0.750-6.30	0.750	6.30	1.30	1.65	2.05	M16X1	AD Thru
	9474A2132	HSK-63A-SF 1.000-6.30	1.000	6.30	1.73	2.09	2.44	M16X1	AD Thru
	9474A2232	HSK-63A-SF 1.250-6.30	1.250	6.30	1.73	2.09	2.28	M16X1	AD Thru
HSK63A Metric	9474A0332	HSK-63A-SF 3-160	3	160	10	18	9	-	AD Thru
	9474A0432	HSK-63A-SF 4-160	4	160	10	18	12	-	AD Thru
	9474A0532	HSK-63A-SF 5-160	5	160	10	18	15	-	AD Thru
	9474A0632	HSK-63A-SF 6-160	6	160	21	27	36	M5	AD Thru
	9474A0832	HSK-63A-SF 8-160	8	160	21	27	36	M6	AD Thru
	9474A1032	HSK-63A-SF 10-160	10	160	24	32	42	M8X1	AD Thru
	9474A1232	HSK-63A-SF 12-160	12	160	24	32	47	M10X1	AD Thru
	9474A1432	HSK-63A-SF 14-160	14	160	27	34	47	M10X1	AD Thru
	9474A1632	HSK-63A-SF 16-160	16	160	27	34	50	M12X1	AD Thru
	9474A1832	HSK-63A-SF 18-160	18	160	33	42	50	M12X1	AD Thru
	9474A2032	HSK-63A-SF 20-160	20	160	33	42	52	M16X1	AD Thru
	9474A2532	HSK-63A-SF 25-160	25	160	44	53	58	M16X1	AD Thru
	9474A3232	HSK-63A-SF 32-160	32	160	44	53	62	M16X1	AD Thru

NOTE:

AccuGrip™ is available with AccuKool™ ports.

To request make the following changes to part no. and descriptions :

Example : 9474A1732 becomes 9474A1732-3CP.

The description goes from HSK-63A-SF .625-3.74 to HSK-63A-SF-1K3 .625-3.74.

Coolant tubes **on page 200**

Coolant Tube Wrenches **on page 204**

AccuGrip™ Shrink Fit Technology Offering

HSK100A AccuGrip™ Shrink Fit Holders – Standard DIN Length

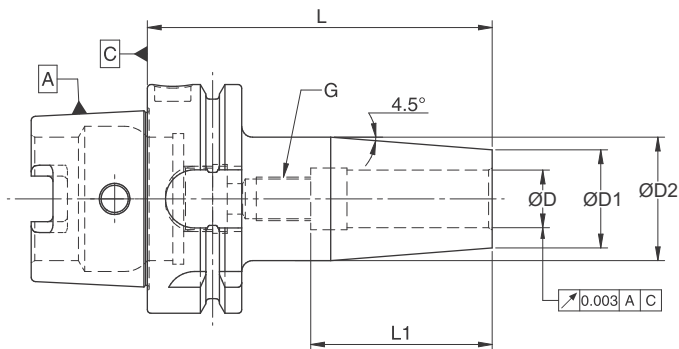

FEATURES

- Balanced to G2.5 @25,000 RPM
- T.I.R. < 0.00012" / 0.003μ

	Catalog Number	Description	ØD	L	ØD1	ØD2	L1	g	Coolant Style
HSK100A Inch	9476A1117	HSK100A-SF 0.250-3.35	0.250	3.35	0.83	1.06	1.42	M5	AD Thru
	9476A2618	HSK100A-SF 0.375-3.54	0.375	3.54	0.94	1.26	1.65	M8X1	AD Thru
	9476A1519	HSK100A-SF 0.500-3.74	0.500	3.54	1.06	1.34	1.85	M10X1	AD Thru
	9476A1720	HSK100A-SF 0.625-3.94	0.625	3.94	1.06	1.34	1.97	M12X1	AD Thru
	9476A2821	HSK100A-SF 0.750-4.13	0.750	4.13	1.30	1.65	2.05	M16X1	AD Thru
	9476A2124	HSK100A-SF 1.000-4.72	1.000	4.72	1.73	2.09	2.28	M16X1	AD Thru
	9476A2224	HSK100A-SF 1.250-4.72	1.250	4.72	1.73	2.09	2.44	M16X1	AD Thru
HSK100A Metric	9476A0617	HSK100A-SF 6-85	6	85	21	27	36	M5	AD Thru
	9476A0817	HSK100A-SF 8-85	8	85	21	27	36	M6	AD Thru
	9476A1018	HSK100A-SF 10-90	10	90	24	32	42	M8X1	AD Thru
	9476A1219	HSK100A-SF 12-95	12	95	24	32	47	M10X1	AD Thru
	9476A1419	HSK100A-SF 14-95	14	95	27	34	47	M10X1	AD Thru
	9476A1620	HSK100A-SF 16-100	16	100	27	34	50	M12X1	AD Thru
	9476A1820	HSK100A-SF 18-100	18	100	33	42	50	M12X1	AD Thru
	9476A2021	HSK100A-SF 20-105	20	105	33	42	52	M16X1	AD Thru
	9476A2523	HSK100A-SF 25-115	25	115	44	53	58	M16X1	AD Thru
	9476A3224	HSK100A-SF 32-120	32	120	44	53	62	M16X1	AD Thru

NOTE:

AccuGrip™ is available with AccuKool™ ports.

To request make the following changes to part no. and descriptions :

Example : 9476A1720 becomes 9476A1720-3CP.

The description goes from HSK-100A-SF 0.625-3.94 to HSK-100A-SF-1K3 .625-3.94.

Coolant tubes **on page 200**

Coolant Tube Wrenches **on page 204**

AccuGrip™ Shrink Fit Technology Offering

HSK63F AccuGrip™ Shrink Fit Holders – Standard DIN Length

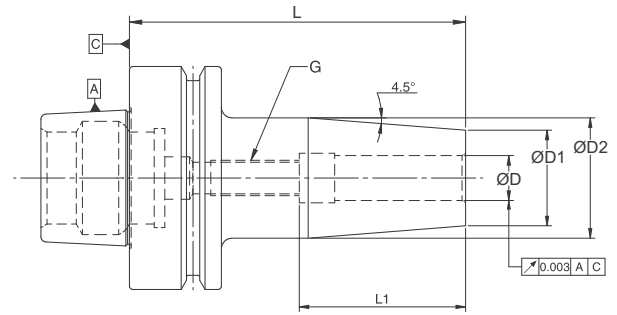

FEATURES

- Balanced to G2.5 @25,000 RPM
- T.I.R. < 0.00012" / 0.003µ

	Catalog Number	Description	ØD inch	L inch	ØD1 inch	ØD2	L1	g	Coolant Style
HSK63F Inch	9474F1118	HSK-63F-SF 0.250-3.54	0.250	3.54	0.83	1.06	1.42	M5	AD Thru
	9474F2618	HSK-63F-SF 0.375-3.54	0.375	3.54	0.95	1.26	1.65	M8X1	AD Thru
	9474F1519	HSK-63F-SF 0.500-3.74	0.500	3.74	1.06	1.34	1.85	M10X1	AD Thru
	9474F1719	HSK-63F-SF 0.625-3.74	0.625	3.74	1.06	1.34	1.97	M12X1	AD Thru
	9474F2820	HSK-63F-SF 0.750-3.94	0.750	3.94	1.30	1.65	2.05	M16X1	AD Thru
	9474F2123	HSK-63F-SF 1.000-4.53	1.000	4.53	1.73	2.09	2.28	M16X1	AD Thru
	9474F2224	HSK-63F-SF 1.250-4.72	1.250	4.72	1.73	2.09	2.44	M16X1	AD Thru

NOTE:

AccuGrip™ is available with AccuKool™ ports.

To request make the following changes to part no. and descriptions :

Example : 9474F1719 becomes 9474F1719-3CP.

The description goes from HSK-63F-SF .625-3.74 to HSK-63F-SF-IK3 .625-3.74.

Straight Shank Extension AccuGrip™ Shrink Fit Holders

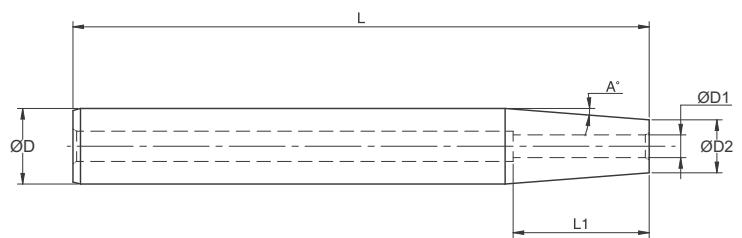

FEATURES

- T.I.R. < 0.00012" / 0.003µ
- Shank Tolerance H6
- Coolant-Thru Body

	Catalog Number	Description	ØD (inch)	ØD1 (inch)	ØD2 (inch)	L	L1	A
STRAIGHT Shank	94451121	SSH.750-SF.250-4.15	0.750	0.2500	0.472	4.15	1.417	3.0
	94451321	SSH.750-SF.3125-4.15	0.750	0.3125	0.551	4.15	1.417	3.0
	94452621	SSH.750-SF.375-4.15	0.750	0.3750	0.630	4.15	1.653	3.0
	94511521	SSH1.00-SF.500-4.15	1.000	0.5000	0.708	4.15	1.850	3.0
	94511141	SSH1.00-SF.250-8.00	1.000	0.2500	0.472	8.00	1.417	3.0
	94511341	SSH1.00-SF.3125-8.00	1.000	0.3125	0.551	8.00	1.417	3.0
	94512641	SSH1.00-SF.375-8.00	1.000	0.3750	0.630	8.00	1.653	3.0
	94511541	SSH1.00-SF.500-8.00	1.000	0.5000	0.708	8.00	1.850	3.0

AccuGrip™ Shrink Fit Technology Offering

PTI AccuGrip™ Shrink Fit Holders – Standard DIN Length

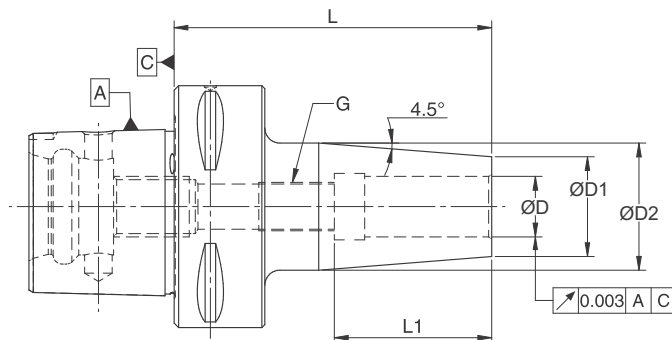

FEATURES

- Balanced to G2.5 @25,000 RPM
- T.I.R. < 0.00012" / 0.003μ

	Catalog Number	Description	ØD (mm)	L (mm)	ØD1 (mm)	ØD2 (mm)	L1 (mm)	g	Coolant Style
PTI50 Metric	94680316	PTI50-SF 3-75	3	75	10	18	9	-	AD Thru
	94680416	PTI50-SF 4-75	4	75	10	18	12	-	AD Thru
	94680516	PTI50-SF 5-75	5	75	10	18	15	-	AD Thru
	94680616	PTI50-SF 6-75	6	75	21	27	36	M5	AD Thru
	94680816	PTI50-SF 8-75	8	75	21	27	36	M6x1	AD Thru
	94681016	PTI50-SF 10-75	10	75	24	32	42	M8x1	AD Thru
	94681216	PTI50-SF 12-75	12	75	24	32	47	M10x1	AD Thru
PTI63 Metric	94690316	PTI63-SF 3-80	3	80	10	18	9	-	AD Thru
	94690416	PTI63-SF 4-80	4	80	10	18	12	-	AD Thru
	94690516	PTI63-SF 5-80	5	80	10	18	15	-	AD Thru
	94690616	PTI63-SF 6-80	6	80	21	27	36	M5	AD Thru
	94690816	PTI63-SF 8-80	8	80	21	27	36	M6x1	AD Thru
	94691017	PTI63-SF 10-85	10	80	24	32	42	M8x1	AD Thru
	94691217	PTI63-SF 12-85	12	80	24	32	47	M10x1	AD Thru
	94691618	PTI63-SF 16-90	16	85	27	42	50	M12x1	AD Thru
94692019	PTI63-SF 20-95	20	85	33	42	50	M16x1	AD Thru	
PTI80 Metric	94700618	PTI80-SF 6-90	6	80	21	27	36	M5	AD Thru
	94700818	PTI80-SF 8-90	8	80	21	27	36	M6x1	AD Thru
	94701018	PTI80-SF 10-90	10	80	24	32	42	M8x1	AD Thru
	94701219	PTI80-SF 12-95	12	80	24	32	47	M10x1	AD Thru
	94701619	PTI80-SF 16-95	16	85	27	42	50	M12x1	AD Thru
	94702019	PTI80-SF 20-95	20	85	33	42	50	M16x1	AD Thru

NOTE:

AccuGrip™ is available with AccuKool™ ports.

To request make the following changes to part no. and descriptions :

Example : 94691017 becomes 94691017-3CP.

The description goes from PTI-63-SF 10-85 to PTI-63-SF-3CP 10-85.

AccuGrip™ Shrink Fit Technology Offering

PTI AccuGrip™ Shrink Fit Holders – Standard DIN Length

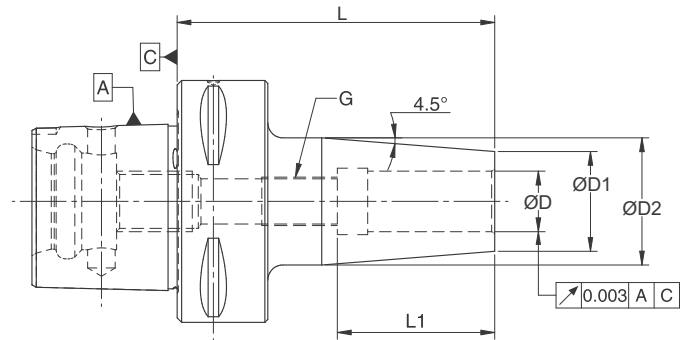

FEATURES

- Balanced to G2.5 @25,000 RPM
- T.I.R. < 0.00012" / 0.003μ

	Catalog Number	Description	ØD (inch)	L (inch)	ØD1 (inch)	ØD2 (inch)	L1 (inch)	g	Coolant Style
PTI50 Inch	94680716	PTI50-SF 0.125-3.15	0.125	3.15	0.39	0.71	0.35	-	AD Thru
	94680916	PTI50-SF 0.187-3.15	0.187	3.15	0.39	0.71	0.47	-	AD Thru
	94681116	PTI50-SF 0.250-3.15	0.250	3.15	0.83	1.06	1.42	M5	AD Thru
	94682616	PTI50-SF 0.375-3.15	0.375	3.15	0.95	1.26	1.65	M8x1	AD Thru
	94681516	PTI50-SF 0.500-3.15	0.500	3.15	1.06	1.34	1.85	M10x1	AD Thru
	94682816	PTI50-SF 0.750-3.15	0.750	3.15	1.06	1.34	1.97	M12x1	AD Thru
	94682123	PTI50-SF 1.000-4.53	1.000	4.53	1.73	2.09	2.44	M16x1	AD Thru
PTI63 Inch	94690716	PTI63-SF 0.125-3.15	0.125	3.15	0.39	0.71	0.35	-	AD Thru
	94690916	PTI63-SF 0.187-3.15	0.187	3.15	0.39	0.71	0.47	-	AD Thru
	94691116	PTI63-SF 0.250-3.15	0.250	3.15	0.83	1.06	1.42	M5	AD Thru
	94692616	PTI63-SF 0.375-3.15	0.375	3.15	0.95	1.26	1.65	M8x1	AD Thru
	94691516	PTI63-SF 0.500-3.15	0.500	3.15	1.06	1.34	1.85	M10x1	AD Thru
	94691717	PTI63-SF 0.625-3.35	0.625	3.35	1.06	1.34	1.97	M12x1	AD Thru
	94692817	PTI63-SF 0.750-3.35	0.750	3.35	1.30	1.65	2.05	M16x1	AD Thru
	94692118	PTI63-SF 1.000-3.54	1.000	3.54	1.73	2.09	2.44	M16x1	AD Thru
PTI80 Inch	94701118	PTI80-SF 0.250-3.54	0.250	3.54	0.83	1.06	1.42	M5	AD Thru
	94702718	PTI80-SF 0.375-3.54	0.375	3.54	0.95	1.26	1.65	M8x1	AD Thru
	94701518	PTI80-SF 0.500-3.54	0.500	3.54	1.06	1.34	1.85	M10x1	AD Thru
	94701719	PTI80-SF 0.625-3.74	0.625	3.74	1.06	1.34	1.97	M12x1	AD Thru
	94702819	PTI80-SF 0.750-3.74	0.750	3.74	1.30	1.65	2.05	M16x1	AD Thru
	94702119	PTI80-SF 1.000-3.74	1.000	3.74	1.73	2.09	2.29	M16x1	AD Thru

NOTE:

AccuGrip™ is available with AccuKool™ ports.

To request make the following changes to part no. and descriptions :

Example : 94691717 becomes 94691717-3CP.

The description goes from PTI-63-SF .625-3.35 to PTI-63-SF-3CP .625-3.35.

AccuGrip™ Shrink Fit Technology Offering

AccuPlus™ CATP40 Face Contact AccuGrip™ Shrink Fit Holders

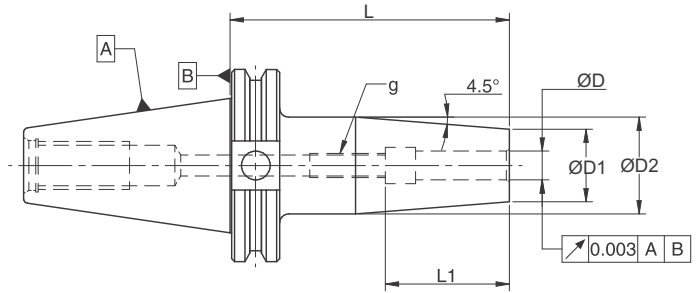

FEATURES

- Balanced to G2.5 @25,000 RPM
- T.I.R. < 0.00012" / 0.003µ
- Taper shank ground to AT3 accuracy (or better)
- AccuPlus Meets all Big Diashowa Patented dimensions

	Catalog Number	Description	ØD (inch)	L (inch)	ØD1 (inch)	ØD2 (inch)	L1 (inch)	g	Coolant Style
CATP40 Inch	941360719	CATP40-SF 0.125-3.74	0.125	3.74	0.39	0.71	0.35	-	AD Thru
	941360919	CATP40-SF 0.187-3.74	0.187	3.74	0.39	0.71	0.47	-	AD Thru
	941361119	CATP40-SF 0.250-3.74	0.250	3.74	0.83	1.06	1.42	M5	AD Thru
	941361319	CATP40-SF 0.312-3.74	0.312	3.74	0.83	1.06	1.42	M6x1	AD Thru
	941362619	CATP40-SF 0.375-3.74	0.375	3.74	0.95	1.26	1.65	M8x1	AD Thru
	941361519	CATP40-SF 0.500-3.74	0.500	3.74	1.06	1.34	1.85	M10x1	AD Thru
	941361719	CATP40-SF 0.625-3.74	0.625	3.74	1.06	1.34	1.97	M12x1	AD Thru
	941362819	CATP40-SF 0.750-3.74	0.750	3.74	1.30	1.65	2.05	M16x1	AD Thru
	941362120	CATP40-SF 1.000-3.94	1.000	3.94	1.73	2.09	2.44	M16x1	AD Thru
	941362220	CATP40-SF 1.250-3.94	1.250	3.94	1.73	2.09	2.44	M16x1	AD Thru

	Catalog Number	Description	ØD (mm)	L (mm)	ØD1 (mm)	ØD2 (mm)	L1 (mm)	g	Coolant Style
CATP40 Metric	941360319	CATP40-SF 3-95	3	95	10	18	9	-	AD Thru
	941360419	CATP40-SF 4-95	4	95	10	18	12	-	AD Thru
	941360519	CATP40-SF 5-95	5	95	10	18	15	-	AD Thru
	941360619	CATP40-SF 6-95	6	95	21	27	36	M5	AD Thru
	941360819	CATP40-SF 8-95	8	95	21	27	36	M6x1	AD Thru
	941361019	CATP40-SF 10-95	10	95	24	32	42	M8x1	AD Thru
	941361219	CATP40-SF 12-95	12	95	24	32	47	M10x1	AD Thru
	941361419	CATP40-SF 14-95	14	95	27	34	47	M10x1	AD Thru
	941361619	CATP40-SF 16-95	16	95	27	34	50	M12x1	AD Thru
	941361819	CATP40-SF 18-95	18	95	33	42	50	M12x1	AD Thru
	941362019	CATP40-SF 20-95	20	95	33	42	52	M16x1	AD Thru
	941362520	CATP40-SF 25-100	25	100	44	53	58	M16x1	AD Thru
	941363220	CATP40-SF 32-100	32	100	44	53	62	M16x1	AD Thru

NOTE:

AccuGrip™ is available with AccuKool™ ports.
 To request make the following changes to part no. and descriptions :
 Example : 941361719 becomes 941361719-3CP.
 The description goes from CATP40-SF .625-3.74 to CATP40-SF-1K3 .625-3.74.
 Retention knobs on page 198-199

AccuGrip™ Shrink Fit Technology Offering

AccuPlus™ CATP50 Face Contact AccuGrip™ Shrink Fit Holders

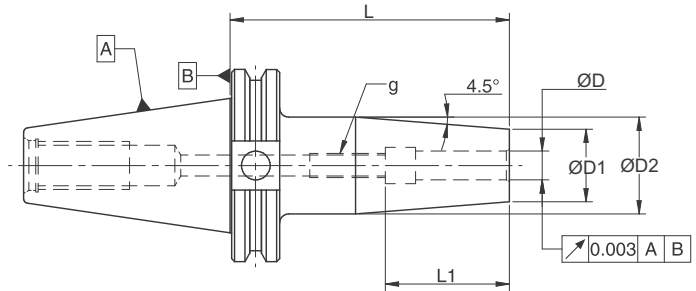

FEATURES

- Balanced to G2.5 @25,000 RPM
- T.I.R. < 0.00012" / 0.003µ
- Taper shank ground to AT3 accuracy (or better)
- AccuPlus Meets all Big Diashowa Patented dimensions

	Catalog Number	Description	ØD (inch)	L (inch)	ØD1 (inch)	ØD2 (inch)	L1 (inch)	g	Coolant Style
CATP50 Inch	941381119	CATP50-SF 0.250-3.74	0.250	3.74	0.83	1.06	1.42	M5	AD Thru
	941382619	CATP50-SF 0.375-3.74	0.375	3.74	0.95	1.26	1.65	M8x1	AD Thru
	941381519	CATP50-SF 0.500-3.74	0.500	3.74	1.06	1.34	1.85	M10x1	AD Thru
	941381719	CATP50-SF 0.625-3.74	0.625	3.74	1.06	1.34	1.97	M12x1	AD Thru
	941382819	CATP50-SF 0.750-3.74	0.750	3.74	1.30	1.65	2.05	M16x1	AD Thru
	941382121	CATP50-SF 1.000-4.13	1.000	4.13	1.73	2.09	2.44	M16x1	AD Thru
	941382221	CATP50-SF 1.250-4.13	1.250	4.13	1.73	2.09	2.44	M16x1	AD Thru

	Catalog Number	Description	ØD (mm)	L (mm)	ØD1 (mm)	ØD2 (mm)	L1 (mm)	g	Coolant Style
CATP50 Metric	941380619	CATP50-SF 6-95	6	95	21	27	36	M5	AD Thru
	941380819	CATP50-SF 8-95	8	95	21	27	36	M6x1	AD Thru
	941381019	CATP50-SF 10-95	10	95	24	32	42	M8x1	AD Thru
	941381219	CATP50-SF 12-95	12	95	24	32	47	M10x1	AD Thru
	941381419	CATP50-SF 14-95	14	95	27	34	47	M10x1	AD Thru
	941381619	CATP50-SF 16-95	16	95	27	34	50	M12x1	AD Thru
	941381819	CATP50-SF 18-95	18	95	33	42	50	M12x1	AD Thru
	941382019	CATP50-SF 20-95	20	95	33	42	52	M16x1	AD Thru
	941382521	CATP50-SF 25-105	25	105	44	53	58	M16x1	AD Thru
	941383221	CATP50-SF 32-105	32	105	44	53	62	M16x1	AD Thru

NOTE:

AccuGrip™ is available with AccuKool™ ports.

To request make the following changes to part no. and descriptions :

Example : 941381719 becomes 941381719-3CP.

The description goes from CATP50-SF .625-3.74 to CATP50-SF-1K3 .625-3.74.

Retention knobs **on page 198-199**

AccuGrip™ Shrink Fit Technology Offering

AccuPlus™ BTP30 Face Contact AccuGrip™ Shrink Fit Holders

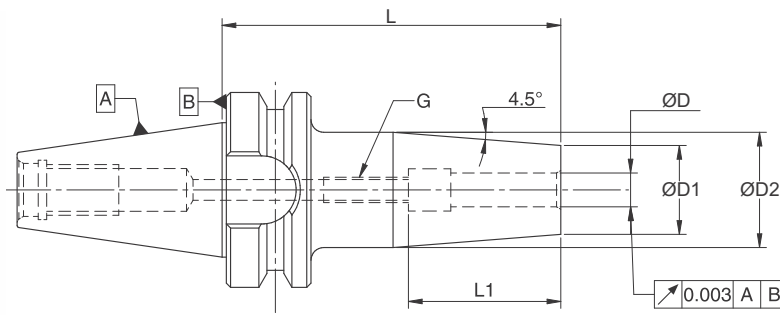

FEATURES

- Balanced to G2.5 @25,000 RPM
- T.I.R. < 0.00012" / 0.003µ
- Bore Tolerance H6
- Taper shank ground to AT3 accuracy (or better)
- AccuPlus Meets all Big Diashowa Patented dimensions

	Catalog Number	Description	ØD (inch)	L (inch)	ØD1 (inch)	ØD2	L1	g	Coolant Style
BTP30 Inch	941060716	BTP30-SF 0.125-3.15	0.125	3.15	0.39	0.71	0.35	-	AD Thru
	941060916	BTP30-SF 0.187-3.15	0.187	3.15	0.39	0.71	0.47	-	AD Thru
	941061116	BTP30-SF 0.250-3.15	0.250	3.15	0.83	1.06	1.42	M5	AD Thru
	941062616	BTP30-SF 0.375-3.15	0.375	3.15	0.95	1.26	1.65	M8x1	AD Thru
	941061516	BTP30-SF 0.500-3.15	0.500	3.15	1.06	1.34	1.85	M10x1	AD Thru
	941061716	BTP30-SF 0.625-3.15	0.625	3.15	1.06	1.34	1.97	M12x1	AD Thru

	Catalog Number	Description	ØD (mm)	L (mm)	ØD1 (mm)	ØD2	L1	g	Coolant Style
BTP30 Metric	941060316	BTP30-SF 3-80	3	80	10	18	9	-	AD Thru
	941060416	BTP30-SF 4-80	4	80	10	18	12	-	AD Thru
	941060516	BTP30-SF 5-80	5	80	10	18	15	-	AD Thru
	941060616	BTP30-SF 6-80	6	80	21	27	36	M5	AD Thru
	941060816	BTP30-SF 8-80	8	80	21	27	36	M6x1	AD Thru
	941061016	BTP30-SF 10-80	10	80	24	32	42	M8x1	AD Thru
	941061216	BTP30-SF 12-80	12	80	24	32	47	M10x1	AD Thru
	941061616	BTP30-SF 16-80	16	80	27	34	50	M12x1	AD Thru
	941062016	BTP30-SF 20-80	20	80	33	42	52	M16x1	AD Thru

NOTE:

AccuGrip™ is available with AccuKool™ ports.
 To request make the following changes to part no. and descriptions :
 Example : 941061716 becomes 941061716-3CP.
 The description goes from BTP30-SF .625-3.15 to BTP30-SF-1K3 .625-3.15.
 Retention knobs on **page 198-199**

AccuGrip™ Shrink Fit Technology Offering

AccuPlus™ BTP40 Face Contact AccuGrip™ Shrink Fit Holders

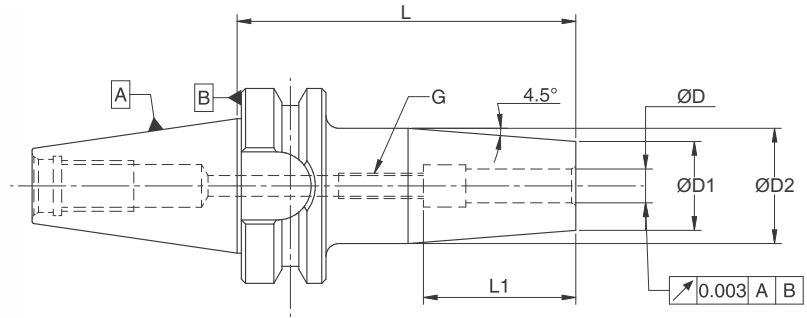

FEATURES

- Balanced to G2.5 @25,000 RPM
- T.I.R. < 0.00012" / 0.003μ
- Taper shank ground to AT3 accuracy (or better)
- AccuPlus Meets all Big Diashowa Patented dimensions

	Catalog Number	Description	ØD (inch)	L (inch)	ØD1 (inch)	ØD2	L1	g	Coolant Style
BTP40 Inch	941080718	BTP40-SF 0.125-3.54	0.125	3.54	0.39	0.71	0.35	-	AD Thru
	941080918	BTP40-SF 0.187-3.54	0.187	3.54	0.39	0.71	0.47	-	AD Thru
	941081118	BTP40-SF 0.250-3.54	0.250	3.54	0.83	1.06	1.42	M5	AD Thru
	941082618	BTP40-SF 0.375-3.54	0.375	3.54	0.95	1.26	1.65	M8x1	AD Thru
	941081518	BTP40-SF 0.500-3.54	0.500	3.54	1.06	1.34	1.85	M10x1	AD Thru
	941081718	BTP40-SF 0.625-3.54	0.625	3.54	1.06	1.34	1.97	M12x1	AD Thru
	941082818	BTP40-SF 0.750-3.54	0.750	3.54	1.30	1.65	2.05	M16x1	AD Thru
	941082120	BTP40-SF 1.000-3.94	1.000	3.94	1.73	2.09	2.44	M16x1	AD Thru
	941082220	BTP40-SF 1.250-3.94	1.250	3.94	1.73	2.09	2.44	M16x1	AD Thru

	Catalog Number	Description	ØD (mm)	L (mm)	ØD1 (mm)	ØD2	L1	g	Coolant Style
BTP40 Metric	941080318	BTP40-SF 3-90	3	80	10	18	9	-	AD Thru
	941080418	BTP40-SF 4-90	4	80	10	18	12	-	AD Thru
	941080518	BTP40-SF 5-90	5	80	10	18	15	-	AD Thru
	941080618	BTP40-SF 6-90	6	80	21	27	36	M5	AD Thru
	941080818	BTP40-SF 8-90	8	80	21	27	36	M6x1	AD Thru
	941081018	BTP40-SF 10-90	10	80	24	32	42	M8x1	AD Thru
	941081218	BTP40-SF 12-90	12	80	24	32	47	M10x1	AD Thru
	941081618	BTP40-SF 16-90	16	80	27	34	50	M12x1	AD Thru
	941082018	BTP40-SF 20-90	20	80	33	42	52	M16x1	AD Thru
	941082520	BTP40-SF 25-100	25	100	44	53	58	M16x1	AD Thru
	941083220	BTP40-SF 32-100	32	100	44	53	58	M16x1	AD Thru

NOTE:

AccuGrip™ is available with AccuKool™ ports.

To request make the following changes to part no. and descriptions :

Example : 941081718 becomes 941081718-3CP.

The description goes from BTP40-SF .625-3.54 to BTP40-SF_IK3 .625-3.54.

Retention knobs **on page 198-199**

AccuGrip™ Shrink Fit Technology Offering (Slim Line)

HSK63A AccuGrip™ Shrink Fit Slim Line Holders

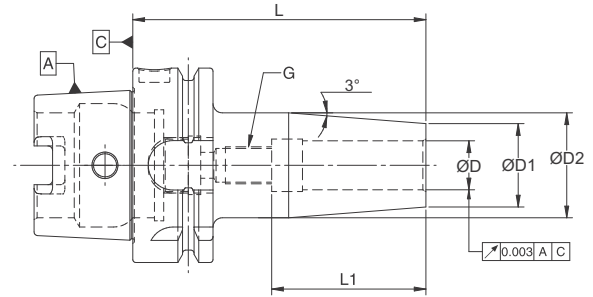

FEATURES

- Balanced to G2.5 @25,000 RPM
- T.I.R. < 0.00012" / 0.003µ

	Catalog Number	Description	ØD	ØD1	ØD2	L	L1	g	Coolant Style
HSK63A Inch	94740714SL	HSK63A-SFSL 0.125-70	0.125	0.390	0.550	2.760	0.790	M6	AD Thru
	94740918SL	HSK63A-SFSL 0.187-90	0.187	0.470	0.710	3.540	0.960	M6	AD Thru
	94741118SL	HSK63A-SFSL 0.250-90	0.250	0.470	0.710	3.540	1.420	M5	AD Thru
	94742618SL	HSK63A-SFSL 0.375-90	0.375	0.630	0.870	3.540	1.650	M8x1	AD Thru
	94741518SL	KSK63A-SFSL 0.500-90	0.500	0.790	1.020	3.540	1.850	M10x1	AD Thru
HSK63A Metric	94740314SL	HSK63A-SFSL 3-70	3	11	13	70	20	M6	AD Thru
	94740414SL	HSK63A-SFSL 4-70	4	11	14	70	20	M6	AD Thru
	94740618SL	HSK63A-SFSL 6-90	6	12	18	90	36	M5	AD Thru
	94740818SL	HSK63A-SFSL 8-90	8	14	20	90	36	M6	AD Thru
	94741018SL	HSK63A-SFSL 10-90	10	16	22	90	42	M8x1	AD Thru
	94741218SL	HSK63A-SFSL 12-90	12	18	24	90	47	M10x1	AD Thru

Coolant tubes on page 200
Coolant Tube Wrenches on page 204

CAT40 AccuGrip™ Shrink Fit Slim Line Holders

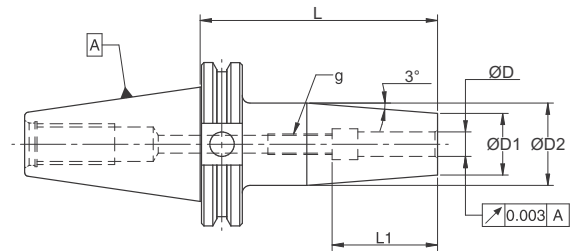

FEATURES

- Balanced to G2.5 @25,000 RPM
- T.I.R. < 0.00012" / 0.003µ
- Taper shank ground to AT3 accuracy (or better)

	Catalog Number	Description	ØD	ØD1	ØD2	L	L1	g	Coolant Style
CAT40 Inch	94240714SL	CAT40-SFSL 0.125-70	0.125	0.390	0.550	2.760	0.790	M6	AD Thru
	94240918SL	CAT40-SFSL 0.187-90	0.187	0.470	0.710	3.540	0.960	M6	AD Thru
	94241118SL	CAT40-SFSL 0.250-90	0.250	0.470	0.710	3.540	1.420	M5	AD Thru
	94242618SL	CAT40-SFSL 0.375-90	0.375	0.630	0.870	3.540	1.650	M8X1	AD Thru
	94241518SL	CAT40-SFSL 0.500-90	0.500	0.790	1.020	3.540	1.850	M10X1	AD Thru
CAT40 Metric	94240314SL	CAT40-SFSL 3-70	3	11	13	70	20	M6	AD Thru
	94240414SL	CAT40-SFSL 4-70	4	11	14	70	20	M6	AD Thru
	94240618SL	CAT40-SFSL 6-90	6	12	18	90	36	M5	AD Thru
	94240818SL	CAT40-SFSL 8-90	8	14	20	90	36	M6	AD Thru
	94241018SL	CAT40-SFSL 10-90	10	16	22	90	42	M8x1	AD Thru
	94241218SL	CAT40-SFSL 12-90	12	18	24	90	47	M10x1	AD Thru

Retention knobs on page 198-199

AccuGrip™ Shrink Fit Technology Offering

AccuGrip KTI Shrink Fit Holders (ISO 26622-1)

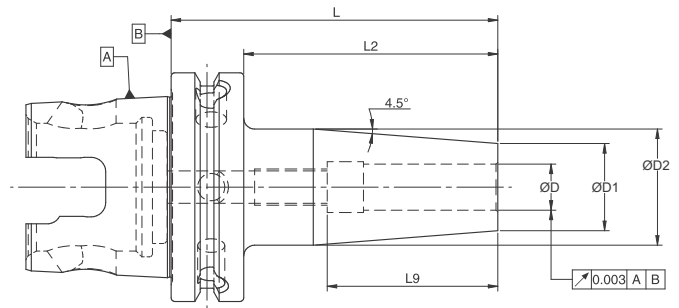

FEATURES

- Balanced to G2.5 @25,000 RPM
- T.I.R. < 0.00012" / 0.003μ

	Catalog Number	Description	ØD	ØD1	ØD2	L	L2	L9	Coolant Style
Metric ID	941500416	KTI63XMZ-SF 4-80	4	10	18	80	60	12	AD Thru
	941500616	KTI63XMZ-SF 6-80	6	21	27	80	60	36	AD Thru
	941500816	KTI63XMZ-SF 8-80	8	21	27	80	60	36	AD Thru
	941501018	KTI63XMZ-SF 10-90	10	24	32	90	70	42	AD Thru
	941501218	KTI63XMZ-SF 12-90	12	24	32	90	70	47	AD Thru
	941501420	KTI63XMZ-SF 14-100	14	27	34	100	80	47	AD Thru
	941501620	KTI63XMZ-SF 16-100	16	27	34	100	80	50	AD Thru
	941501820	KTI63XMZ-SF 18-100	18	33	44	100	80	52	AD Thru
	941502020	KTI63XMZ-SF 20-100	20	33	44	100	80	52	AD Thru
941502524	KTI63XMZ-SF 25-120	25	44	53	120	100	56	AD Thru	
Inch ID	941501116	KTI63XMZ-SF 0.250-3.15	0.25	0.827	1.059	3.150	2.362	1.417	AD Thru
	941501316	KTI63XMZ-SF 0.312-3.15	0.312	0.827	1.059	3.150	2.362	1.417	AD Thru
	941502617	KTI63XMZ-SF 0.375-3.35	0.375	0.945	1.256	3.347	2.559	1.653	AD Thru
	941501518	KTI63XMZ-SF 0.500-3.54	0.50	0.945	1.256	3.543	2.775	1.850	AD Thru
	941501719	KTI63XMZ-SF 0.625-3.74	0.625	1.063	1.335	3.740	2.952	1.968	AD Thru
	941502820	KTI63XMZ-SF 0.750-3.94	0.75	1.299	1.650	3.937	3.149	2.047	AD Thru
	941502123	KTI63XMZ-SF 1.00-4.53	1.00	1.732	2.083	4.528	3.740	2.283	AD Thru
	941502224	KTI63XMZ-SF 1.25-4.72	1.25	1.732	2.083	4.724	3.936	2.440	AD Thru

NOTE:

AccuGrip™ is available with AccuKool™ ports.

To request make the following changes to part no. and descriptions :

Example : 941501719 becomes 941501719-3CP.

The description goes from KTI63-XMZ-SF .625-3.74 to KTI63-XMZ-SF-1K3 .625-3.74.

AccuGrip™ Shrink Fit Technology Offering

AccuGrip™ Modular Slim Holders

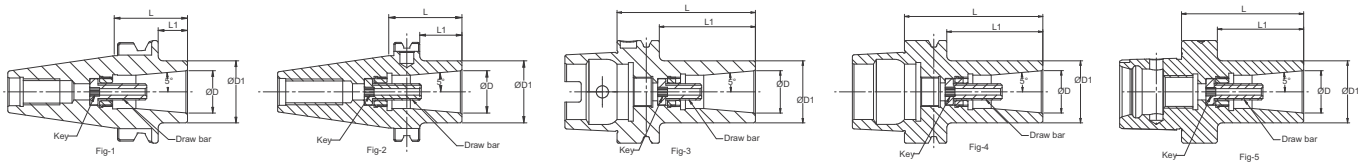

FEATURES

- Balanced to G2.5 @25,000 RPM
- T.I.R. < 0.00012" / 0.003µ

Modular Tool Holder Shanks

	Catalog Number	Description	Ext. Size	ØD mm	ØD1 mm	L	L1	Key	Fig. No.	Draw Bar
BT30	891016807	BT30 SFSEH 12 L-35	12	26.00	38.10	35.00	13.00	5.00	1	DB101.50FS
BT40	891216809	BT40 SFSEH 12 L-45	12	26.00	38.10	45.00	18.00	5.00	1	DB101.50FS
BT50	891416815	BT50 SFSEH 12 L-75	12	26.00	38.10	75.00	37.00	5.00	1	DB101.50FS
BTP30	8910616807	BTP30 SFSEH 12 L-35	12	26.00	38.10	35.00	13.15	5.00	1	DB101.50FS
BTP40	8910816809	BTP40 SFSEH 12 L-45	12	26.00	38.10	45.00	18.00	5.00	1	DB101.50FS
BTP50	8911016815	BTP50 SFSEH 12 L-75	12	26.00	38.10	75.00	37.00	5.00	1	DB101.50FS
CAT40	892416809	CAT40 SFSEH 12 L-45	12	26.00	38.10	45.00	25.95	5.00	2	DB101.50FS
CAT50	892616815	CAT50 SFSEH 12 L-75	12	26.00	38.10	75.00	55.95	5.00	2	DB101.50FS
CATP40	8913616809	CATP40 SFSEH 12 L-45	12	26.00	38.10	45.00	25.95	5.00	2	DB101.50FS
CATP50	8913816815	CATP50 SFSEH 12 L-75	12	26.00	38.10	75.00	55.95	5.00	2	DB101.50FS
HSK50A	8973A16817	HSK50A SFSEH 12 L-85	12	26.00	38.10	85.00	59.00	5.00	3	DB101.50FS
HSK63A	8974A16815	HSK63A SFSEH 12 L-75	12	26.00	38.10	75.00	49.00	5.00	3	DB101.50FS
HSK100A	8976A16819	HSK100A SFSEH 12 L-95	12	26.00	38.10	95.00	66.00	5.00	3	DB101.50FS
HSK50E	8973E16817	HSK50E SFSEH 12 L-85	12	26.00	38.10	85.00	59.00	5.00	4	DB101.50FS
HSK63E	8974E16817	HSK63E SFSEH 12 L-85	12	26.00	38.10	85.00	59.00	5.00	4	DB101.50FS
HSK100E	8976E16819	HSK100E SFSEH 12 L-95	12	26.00	38.10	95.00	66.00	5.00	4	DB101.50FS
PTI40	896716815	PTI40 SFSEH 12 L-75	12	26.00	38.10	75.00	55.00	5.00	5	DB101.50FS
PTI50	896816815	PTI50 SFSEH 12 L-75	12	26.00	38.10	75.00	55.00	5.00	5	DB101.50FS
PTI63	896916815	PTI63 SFSEH 12 L-75	12	26.00	38.10	75.00	53.00	5.00	5	DB101.50FS
PTI80	897016815	PTI80 SFSEH 12 L-75	12	26.00	38.10	75.00	45.00	5.00	5	DB101.50FS

Coolant tubes **on page 200**

Coolant Tube Wrenches **on page 204**

AccuGrip SFS Shrink Fit Extensions offer excellent TIR accuracy and clearance with extended lengths. Excellent product use for 5-Axis machining, Die/Mold work, and applications where clearance in piece part is critical.

Benefits of the AccuGrip SFS Extension System:

- 1) Made from H13 steel for high rigidity at extended lengths
- 2) Standard DIN Slim ID/OD dimensions so heat cycle is at DIN standard settings in Bilz™ and Haimer™ machines
- 3) Internal drawbar is designed to pull back and hold extension accurately and with maximum holding forces
- 4) Interchangeable design allows for application and tooling setup flexibility with multiple ID sizes and Gauge lengths
- 5) TIR accuracy is .0001" from centerline of OD at 3x tool shank diameter
- 6) Coolant through design allows coolant to flow through cutting (if coolant-thru cutting tool design)
- 7) Holders are balanced to G2.5 @ 25,000 RPM
- 8) Excellent design balance between versatility, high accuracy, and easy of use/setup
- 9) Compatible and interchangeable with MST™ SlimLine Product

AccuGrip™ Shrink Fit Technology Offering

AccuGrip™ Modular Slim Extensions (Model SFS)

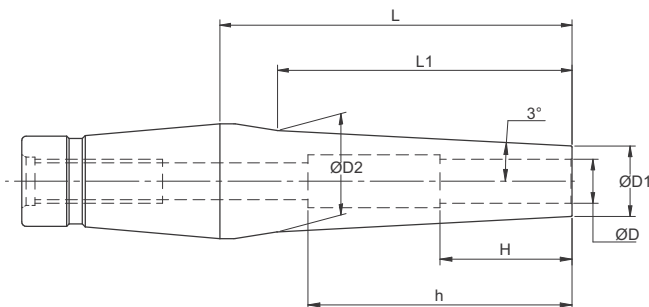

INCH SIZE									
Catalog Number	Description	ØD	ØD1	ØD2	L	L1	H	h	Coolant Style
941680711	SFS 12 0.125 L-2.17	0.125	0.354	0.531	2.17	1.654	0.390	2.56	AD Thru
941680911	SFS 12 0.187 L-2.17	0.187	0.433	0.61	2.17	1.654	0.590	2.56	AD Thru
941681111	SFS 12 0.250 L-2.17	0.250	0.472	0.65	2.17	1.654	0.710	2.56	AD Thru
941682611	SFS 12 0.375 L-2.17	0.375	0.630	0.807	2.17	1.654	0.370	2.36	AD Thru
941681511	SFS 12 0.500 L-2.17	0.500	0.709	0.886	2.17	1.654	1.180	2.36	AD Thru
941680716	SFS 12 0.125 L-3.15	0.125	0.354	0.630	3.15	2.638	0.390	3.35	AD Thru
941680916	SFS 12 0.187 L-3.15	0.187	0.433	0.709	3.15	2.638	0.590	3.35	AD Thru
941681116	SFS 12 0.250 L-3.15	0.250	0.472	0.748	3.15	2.638	0.710	3.35	AD Thru
941682616	SFS 12 0.375 L-3.15	0.375	0.630	0.906	3.15	2.638	0.370	2.36	AD Thru
941681516	SFS 12 0.500 L-3.15	0.500	0.709	0.984	3.15	2.638	1.180	2.36	AD Thru
941680722	SFS 12 0.125 L-4.33	0.125	0.354	0.756	4.33	3.818	0.390	4.33	AD Thru
941680922	SFS 12 0.187 L-4.33	0.187	0.433	0.835	4.33	3.818	0.590	4.33	AD Thru
941681122	SFS 12 0.250 L-4.33	0.250	0.472	0.874	4.33	3.818	0.710	4.33	AD Thru
941682622	SFS 12 0.375 L-4.33	0.375	0.630	1.031	4.33	3.818	0.370	2.36	AD Thru
941681522	SFS 12 0.500 L-4.33	0.500	0.709	1.110	4.33	3.818	1.180	2.36	AD Thru

METRIC SIZE									
Catalog Number	Description	ØD	ØD1	ØD2	L	L1	H	h	Coolant Style
941680311	SFS 12 3.00 L-55.00	3.00	9.00	13.5	55	42	10.00	60.00	AD Thru
941680411	SFS 12 4.00 L-55.00	4.00	10.00	14.5	55	42	12.00	60.00	AD Thru
941680611	SFS 12 6.00 L-55.00	6.00	12.00	16.5	55	42	18.00	60.00	AD Thru
941680811	SFS 12 8.00 L-55.00	8.00	14.00	18.5	55	42	25.00	60.00	AD Thru
941681011	SFS 12 10.00 L-55.00	10.00	16.00	20.5	55	42	30.00	60.00	AD Thru
941681211	SFS 12 12.00 L-55.00	12.00	18.00	22.5	55	42	30.00	60.00	AD Thru
941680316	SFS 12 3.00 L-80.00	3.00	9.00	16	80	67	10.00	80.00	AD Thru
941680416	SFS 12 4.00 L-80.00	4.00	10.00	17	80	67	12.00	80.00	AD Thru
941680616	SFS 12 6.00 L-80.00	6.00	12.00	19	80	67	18.00	80.00	AD Thru
941680816	SFS 12 8.00 L-80.00	8.00	14.00	21	80	67	25.00	80.00	AD Thru
941681016	SFS 12 10.00 L-80.00	10.00	16.00	23	80	67	30.00	60.00	AD Thru
941681216	SFS 12 12.00 L-80.00	12.00	18.00	25	80	67	30.00	60.00	AD Thru
941680322	SFS 12 3.00 L-110.00	3.00	9.00	19.2	110	97	10.00	105.00	AD Thru
941680422	SFS 12 4.00 L-110.00	4.00	10.00	20.2	110	97	12.00	105.00	AD Thru
941680622	SFS 12 6.00 L-110.00	6.00	12.00	22.2	110	97	18.00	105.00	AD Thru
941680822	SFS 12 8.00 L-110.00	8.00	14.00	24.2	110	97	25.00	105.00	AD Thru
941681022	SFS 12 10.00 L-110.00	10.00	16.00	26.2	110	97	30.00	60.00	AD Thru
941681222	SFS 12 12.00 L-110.00	12.00	18.00	28.2	110	97	30.00	60.00	AD Thru

Notes:

A series of horizontal dashed lines for writing notes.

Blanks

CAT Blanks (ANSI/ASME 5.50-1994)

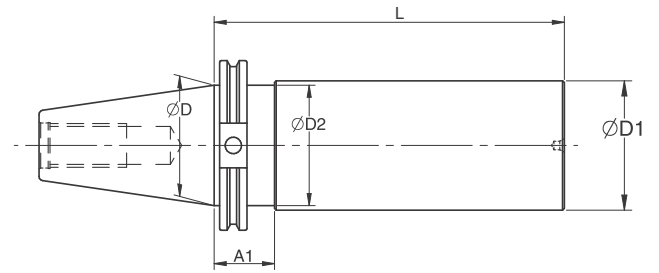

FEATURES

- Shank Hardness 54-56 HRC
- Blank Hardness 28-32 HRC
- Taper shank ground to AT3 accuracy (or better)

	Catalog Number	Description	ØD (mm)	ØD1 (mm)	L (mm)	A1 (mm)	ØD2 (mm)
CAT40	A124040150	CAT40 Blank Dia. 40-150	44.45	40	150	--	--
	A124040200	CAT40 Blank Dia. 40-200	44.45	40	200	--	--
	A124063150	CAT40 Blank Dia. 63-150	44.45	63	150	35	44.45
	A124063200	CAT40 Blank Dia. 63-200	44.45	63	200	35	44.45
	A124090150	CAT40 Blank Dia. 90-150	44.45	90	150	35	44.45
	A124090200	CAT40 Blank Dia. 90-200	44.45	90	200	35	44.45
CAT50	A126075150	CAT50 Blank Dia. 75-150	69.85	75	150	35	69.85
	A126075250	CAT50 Blank Dia. 75-250	69.85	75	250	35	69.85
	A126100175	CAT50 Blank Dia. 100-175	69.85	100	175	35	69.85
	A126100300	CAT50 Blank Dia. 100-300	69.85	100	300	35	69.85
	A126120200	CAT50 Blank Dia. 120-200	69.85	120	200	35	69.85
	A126120300	CAT50 Blank Dia. 120-300	69.85	120	300	35	69.85

CATP AccuPlus™ Face Contact Blank

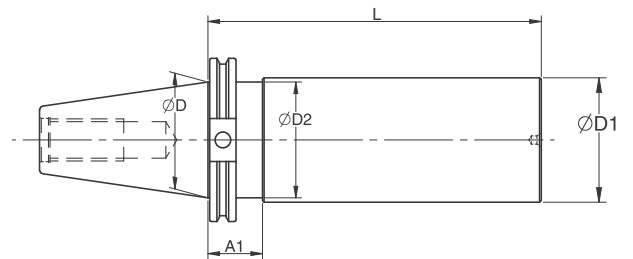

FEATURES

- Shank Hardness 54-56 HRC
- Blank Hardness 28-32 HRC
- Taper shank ground to AT3 accuracy (or better)

	Catalog Number	Description	ØD (mm)	ØD1 (mm)	L (mm)	A1 (mm)	ØD2 (mm)
CATP40	A1136040150	CATP40 Blank Dia 40-150	44.45	40	150	--	--
	A1136040200	CATP40 Blank Dia 40-200	44.45	40	200	--	--
	A1136063150	CATP40 Blank Dia 63-150	44.45	63	150	35	44.45
	A1136063200	CATP40 Blank Dia 63-200	44.45	63	200	35	44.45
	A1136090150	CATP40 Blank Dia 90-150	44.45	90	150	35	44.45
	A1136090200	CATP40 Blank Dia 90-200	44.45	90	200	35	44.45
CATP50	A1136075150	CATP50 Blank Dia 75-150	69.85	75	150	35	69.85
	A1138075250	CATP50 Blank Dia 75-250	69.85	75	250	35	69.85
	A1138100175	CATP50 Blank Dia 100-150	69.85	100	175	35	69.85
	A1138100300	CATP50 Blank Dia 100-300	69.85	100	300	35	69.85
	A1138120200	CATP50 Blank Dia 120-200	69.85	120	200	35	69.85
	A1138120300	CATP50 Blank Dia 120-300	69.85	120	300	35	69.85

Blanks

BT Blanks (MAS 403)

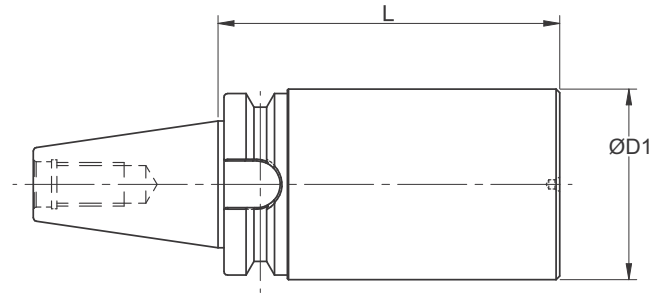

FEATURES

- Shank Hardness 54-56 HRC
- Blank Hardness 28-32 HRC
- Taper shank ground to AT3 accuracy (or better)

	Catalog Number	Description	ØD1 (mm)	L (mm)
BT30 Shank	A110060200	BT30 Blank Dia. 60, GL 200	60	200
	A110060120	BT30 Blank Dia. 60, GL 120	60	120
BT40 Shank	A112063280	BT40 Blank Dia. 63-280	63	280
	A112063200	BT40 BLANK 63-200	63	200
	A112063120	BT40 BLANK 63-120	63	120
	A112104200	BT40 BLANK 104-200	104	200

BTP AccuPlus™ Face Contact Blank Bars

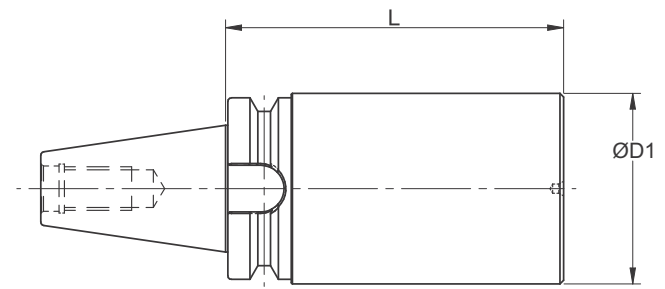

FEATURES

- Shank Hardness 54-56 HRC
- Blank Hardness 28-32 HRC
- Taper shank ground to AT3 accuracy (or better)

	Catalog Number	Description	ØD1 (mm)	L (mm)
BTP30	A1106060125	BTP30 BLANK 60-125	60	125
	A1106090125	BTP30 BLANK 90-125	90	125
BTP40	A1108063280	BTP40 BLANK 63-280	63	280
	A1108104200	BTP40 BLANK 104-200	104	200

Blanks

PTI Blanks (ISO 26623-1)

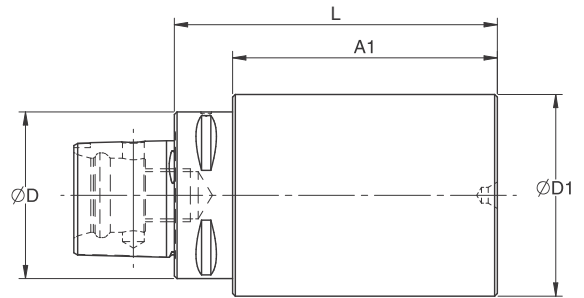

FEATURES

- Shank Hardness 54-56 HRC
- Blank Hardness 28-32 HRC

	Catalog Number	Description	ØD (mm)	ØD1 (mm)	L (mm)	A1 (mm)
PTI32	A166032090	PTI32 Blank Dia. 32-90	32	32	90	-
	A166060090	PTI32 Blank Dia. 60-90	32	60	90	75
PTI40	A167040120	PTI40 Blank Dia. 40-120	40	40	120	-
	A167050180	PTI40 Blank Dia. 50-180	40	50	180	160
	A167080120	PTI40 Blank Dia. 80-120	40	80	120	100
	A167090150	PTI40 Blank Dia. 90-150	40	90	150	130
	A167120120	PTI40 Blank Dia. 120-120	40	120	120	100
PTI50	A168050150	PTI50 Blank Dia. 50-150	50	50	150	-
	A168050200	PTI50 Blank Dia. 50-200	50	50	200	-
	A168063180	PTI50 Blank Dia. 63-180	50	63	180	160
	A168090180	PTI50 Blank Dia. 90-180	50	90	180	160
	A168095150	PTI50 Blank Dia. 95-150	50	95	150	130
	A168120200	PTI50 Blank Dia. 120-200	50	120	200	180
	A168150150	PTI50 Blank Dia. 150-150	50	150	150	130
PTI63	A169063180	PTI63 Blank Dia. 63-180	63	63	180	-
	A169070200	PTI63 Blank Dia. 70-200	63	70	200	178
	A169090200	PTI63 Blank Dia. 90-200	63	90	200	178
	A169110120	PTI63 Blank Dia. 110-120	63	110	120	98
	A169120150	PTI63 Blank Dia. 120-150	63	120	150	128
	A169120180	PTI63 Blank Dia. 120-180	63	120	180	158
	A169180120	PTI63 Blank Dia. 180-120	63	180	120	98
	A169220120	PTI63 Blank Dia. 220-120	63	220	120	98
PTI80	A170080200	PTI80 Blank Dia. 80-200	80	80	200	-
	A170090200	PTI80 Blank Dia. 90-200	80	90	200	170
	A170100200	PTI80 Blank Dia. 100-200	80	100	200	170
	A170110250	PTI80 Blank Dia. 110-250	80	110	250	220
	A170145200	PTI80 Blank Dia. 145-200	80	145	200	170
	A170150200	PTI80 Blank Dia. 150-200	80	150	200	170
	A170160120	PTI80 Blank Dia. 160-120	80	160	120	90
	A170180120	PTI80 Blank Dia. 180-120	80	180	120	90

Blanks

KTI-TS Blank Bars (ISO 26622-1)

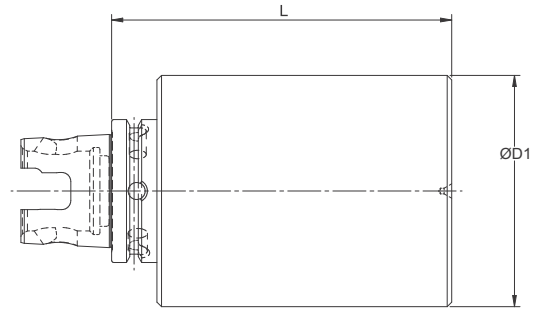

FEATURES

- Shank Hardness 54-56 HRC
- Blank Hardness 28-32 HRC

	Catalog Number	Description	ØD1 (mm)	L (mm)
KTI40TS	A1141063052	KTI40TS-BLANK 63X52	63	52
	A1141063125	KTI40TS-BLANK 63X125	63	125
	A1141090052	KTI40TS-BLANK 90X52	90	52
KTI50TS	A1142120100	KTI50TS-BLANK 120-100	120	100
KTI6350	A1156075175	KTI6350-BLANK 75-175	75	175

HSK Blanks (DIN 69893-1)

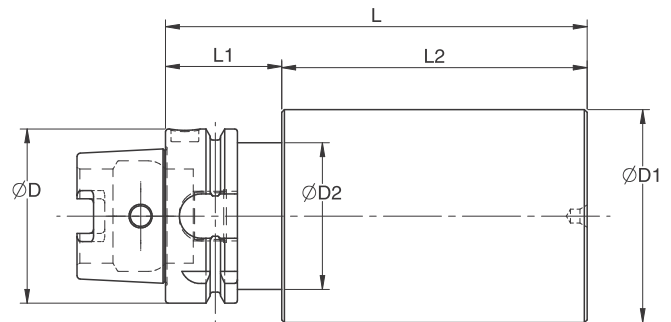

FEATURES

- Shank Hardness 54-56 HRC
- Blank Hardness 28-32 HRC

	Catalog Number	Description	ØD (mm)	ØD1 (mm)	ØD2 (mm)	L (mm)	L1 (mm)	L2 (mm)
HSK32A	A171A032090	HSK32A BLANK DIA 32-90	32	32	26	90	35	55
	A171A060090	HSK32A BLANK DIA 60-90	32	60	26	90	35	55
HSK40A	A172A040120	HSK40A BLANK DIA 40-120	40	40	34	120	35	85
	A172A040120	HSK40A BLANK DIA 80-120	40	80	34	120	35	85
HSK50A	A173A050100	HSK50A BLANK DIA 50-100	50	50	42	100	42	108
	A173A050150	HSK50A BLANK DIA 95-150	50	95	42	150	42	108
HSK63A	A174A063180	HSK63A BLANK DIA 63-180	63	63	53	180	42	138
	A174A120180	HSK63A BLANK DIA 120-180	63	120	53	180	42	138
HSK80A	A175A080120	HSK80A BLANK DIA 80-120	80	80	68	120	42	158
	A175A145200	HSK80A BLANK DIA 145-200	80	145	68	200	42	158
HSK100A	A176A145200	HSK100A BLANK DIA 145-200	100	145	88	200	45	155

Coolant tubes [on page 200](#)
Coolant Tube Wrenches [on page 204](#)

Spindle Test Mandrel

Spindle Test Mandrels (3 μm / .0001" TIR)

for spindle run-out checking and spindle and table alignment

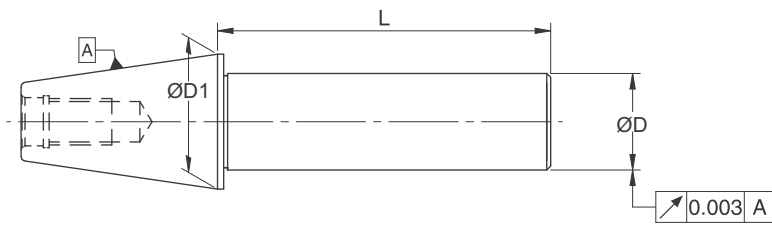

	Catalog Number	Description	ØD1	ØD (mm)	L (mm)
Cat Shank (ANSI/ASME B5.50-1994)	A2244060	CAT40 Test Mandrel Dia. 40-300	44.45	40	300
	A2264070	CAT50 Test Mandrel Dia. 40-350	69.85	40	350

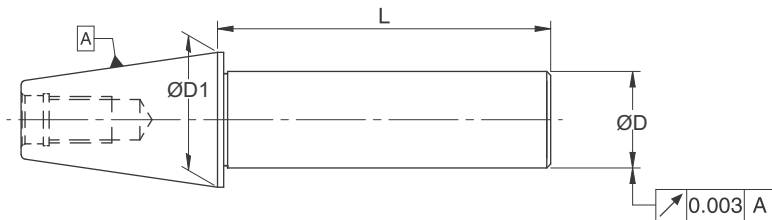

	Catalog Number	Description	ØD1	ØD (mm)	L (mm)
BT shank (MAS 403)	A2102540	BT30 Test Mandrel Dia. 25-200	31.75	25	200
	A2112540	BT35 Test Mandrel Dia. 25-200	38.10	25	200
	A2124060	BT40 Test Mandrel Dia. 40-300	44.45	40	300
	A2144070	BT50 Test Mandrel Dia. 40-350	69.85	40	350

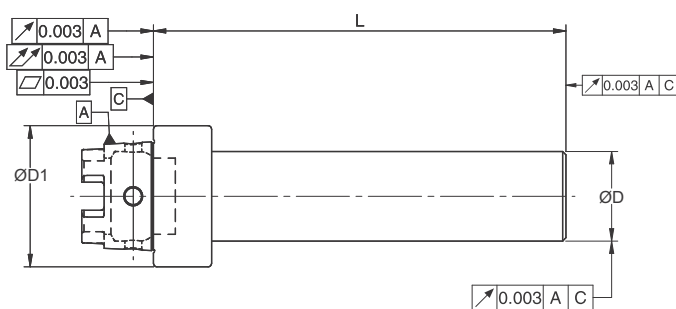

	Catalog Number	Description	ØD1	ØD (mm)	L (mm)
HSK Shank (DIN 69893A)	A271A2540	HSK32A Test Mandrel Dia. 25-200	32	25	200
	A272A3240	HSK40A Test Mandrel Dia. 32-200	40	32	200
	A273A4050	HSK50A Test Mandrel Dia. 40-250	50	40	250
	A274A4070	HSK63A Test Mandrel Dia. 40-350	63	40	350
	A275A4070	HSK80A Test Mandrel Dia. 40-350	80	40	350
	A276A4076	HSK100A Test Mandrel Dia. 40-380	100	40	380
	A277A5080	HSK125A Test Mandrel Dia. 50-400	125	50	400

Spindle Test Mandrel

AccuLoc™ PTI Spindle Test Mandrel (3 μm / .0001" TIR)

for spindle run-out checking and spindle and table alignment

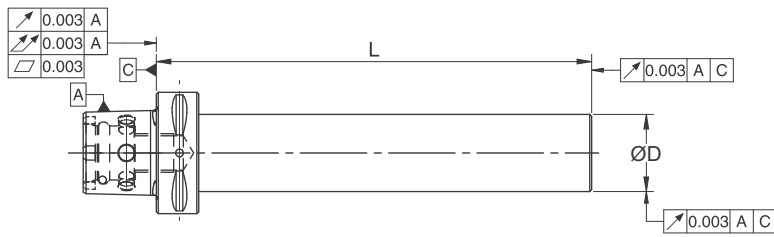

	Catalog Number	Description	ØD1	ØD (mm)	L (mm)
PTI Shank (ISO 26623-1)	A2662536	PTI32 Test Mandrel Dia. 25-180	32	25	180
	A2672536	PTI40 Test Mandrel Dia. 25-180	40	25	180
	A2683251	PTI50 Test Mandrel Dia. 32-255	50	32	255
	A2694065	PTI63 Test Mandrel Dia. 40-325	63	40	325
	A2704066	PTI80 Test Mandrel Dia. 40-330	80	40	330

AccuPlus™ Steep Taper Face Contact Spindle Test Mandrel (3 μm / .0001" TIR)

for spindle run-out checking and spindle and table alignment

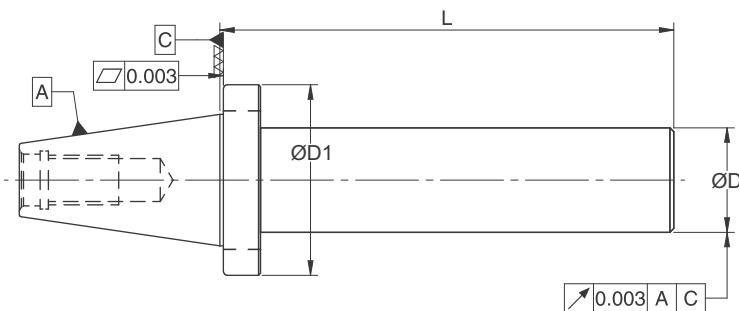

	Catalog Number	Description	ØD1	ØD (mm)	L (mm)
CATP Shank (ANSI/ASME B5.50 - 1994)	A21364060	CATP40 Test Mandrel Dia. 40-300	63.5	40	300
	A21384070	CATP50 Test Mandrel Dia. 40-350	98.43	40	350

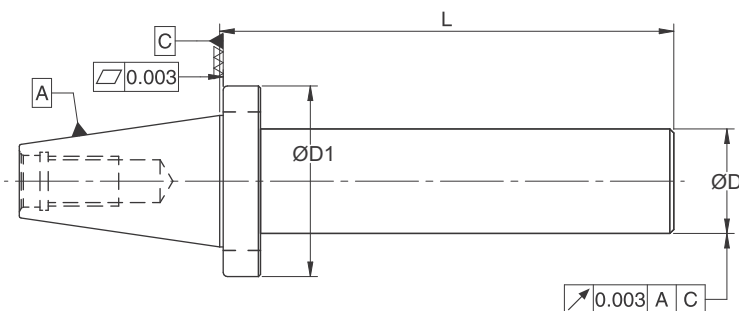

	Catalog Number	Description	ØD1	ØD (mm)	L (mm)
BTP Shank (MAS 403)	A21062540	BTP30 Test Mandrel Dia. 25-200	46	25	200
	A21084060	BTP40 Test Mandrel Dia. 40-300	63	40	300
	A21104070	BTP50 Test Mandrel Dia. 40-350	100	40	350

Spindle Test Mandrel

AccuLoc™ ER COLLET Spindle Test Mandrel (5 μm / .000196" TIR)

for spindle run-out checking and spindle and table alignment

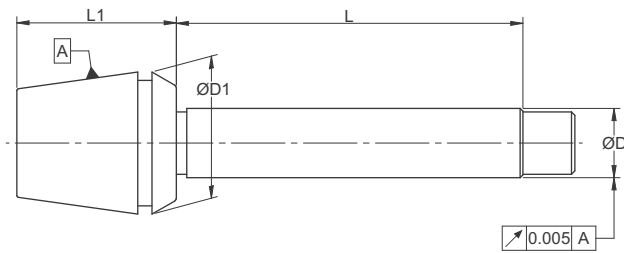

	Catalog Number	Description	ØD1	ØD (mm)	L1 (mm)	L (mm)
ER COLLET (DIN 6499)	A200520	ER11 Test Mandrel Dia. 05-100	11.5	5.00	18	100
	A210720	ER16 Test Mandrel Dia. 07-100	17.0	7.00	27	100
	A221020	ER20 Test Mandrel Dia. 10-100	21.0	10.00	31	100
	A231320	ER25 Test Mandrel Dia. 13-100	26.0	13.00	35	100
	A241620	ER32 Test Mandrel Dia. 16-100	33.0	16.00	40	100
	A252020	ER40 Test Mandrel Dia. 20-100	41.0	20.00	46	100
	A272520	ER50 Test Mandrel Dia. 25-100	51.85	25.00	60	100

Accutek Manufacturing Tip #3

Spindle run-out - No matter how accurate your cutting tool or tool holder are, if your spindle is out of alignment or has spindle bearing run-out, your part processing accuracy will only be as good and accurate as the machine allows you to control. Spindle alignment should be checked every 90 days or no less than twice per year regardless of machine usage. It also should be checked after any "crash" or "Spindle/toolholder contact" with fixtures, part, or any object not being machined. Using a high quality, high precision certified Test Arbor is critical. Load the Test Arbor in the machine spindle manually and using a .0001" Dial Indicator, check spindle rotation at the diameter closest to the spindle face, halfway down the test arbor shaft, and 1.0" from end of test arbor shaft and compare readings to determine if there is spindle bearing or spindle taper run-out. Then starting at the end of the test arbor, run the indicator the entire length of the test arbor shaft to determine if there is mis-alignment with the table surface as the spindle should rotate at a perfect 90° angle to the table of fixture. Any abnormal alignment or rotational error should be corrected as soon as it is detected to improve machining processes but also protect spindle and tooling from excessive wear.



Standard Steep Taper



HSK Taper



Polygon Taper



Face Contact Taper

BT / CAT Tools Changer Alignment Tools

Model : BT Tools Changer Alignment Tools

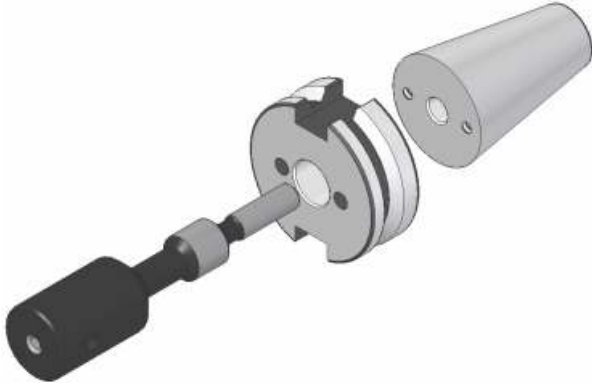

Model	Ordering Number
BT30 Tools Changer Alignment Tools	A7,10,000
BT40 Tools Changer Alignment Tools	A7,12,000
BT50 Tools Changer Alignment Tools	A7,14,000

Model : CAT Tools Changer Alignment Tools



Model	Ordering Number
CAT40 Tools Changer Alignment Tools	A7,24,000
CAT50 Tools Changer Alignment Tools	A7,26,000

PTI / HSK Tools Changer Alignment Tools

Model : PTI Tools Changer Alignment Tools



Model	Ordering Number
PTI 40 Tools Changer Alignment Tools	A7,67,000
PTI 50 Tools Changer Alignment Tools	A7,68,000
PTI 63 Tools Changer Alignment Tools	A7,69,000
PTI 80 Tools Changer Alignment Tools	A7,70,000

Model : HSK Tools Changer Alignment Tools



Model	Ordering Number
HSK 40 Tools Changer Alignment Tools	A7,72,000
HSK 50 Tools Changer Alignment Tools	A7,73,000
HSK 63 Tools Changer Alignment Tools	A7,74,000
HSK 80 Tools Changer Alignment Tools	A7,75,000
HSK100 Tools Changer Alignment Tools	A7,76,000

Tapping Systems and Accessories

Quick Change Tapping Systems for CNC Machine Tools

Accutek is a global provider of quick change tapping products for all CNC metalworking machine tools available. Our product offering includes tap holders, tap adapters, and tapping heads – both non-reversible and reversible styles. Today's tapping applications require multiple technologies to support the numerous metalworking applications requiring tapping and threading operations. The various machine tools, materials, and threaded-hole applications continue to demand innovative tooling designs to accurately produce the desired thread results, cutting tool life, and accurate thread sizes and profiles.

Following are examples of Accutek Tapping products designed to bring tapping technology to your hole-threading applications:

Rigid Tapping Holders – QCK-IK

- For use where synchronized spindle feed is incorporated into the machine tool control software
- Basic Quick Change tap holding system
- Choices of various taper shanks including steep taper (CAT and MAS-BT), HSK, Polygon shank, and KTI shank.
- Choices of other various shanks for additional spindle connections: Morse Taper, Acme shank, Straight Shank, and TR shank.
- Coolant -thru up to 20 bar/300 psi

Compensating Tapping Holders – QCLK

- Tension and Compression axial length compensating style allows for compensation between spindle speed/feed and tap pitch.
- Choices of various taper shanks including steep taper (CAT and MAS-BT), HSK, Polygon shank, and KTI shank.
- Choices of other various shanks for additional spindle connections: Morse Taper, Acme shank, Straight Shank, and TR shank.

Compensating Tapping Holders – QCLC-IK (High Pressure Coolant)

- Tension and Compression axial length compensating style allows for compensation between spindle speed/feed and tap pitch.
- Choices of various taper shanks including steep taper (CAT and MAS-BT), HSK, Polygon shank, and KTI shank.
- Choices of other various shanks for additional spindle connections: Morse Taper, Acme shank, Straight Shank, and TR shank.
- Coolant -thru up to 50 bar/725 psi

Compensating Tapping Holders with Radial Parallel Float – QCFLX

- Tension and Compression axial length compensation
- Radial Parallel float for cutting tool and hole alignment
- Choices of other various shanks for additional spindle connections: Morse Taper, Acme shank, Straight Shank, and TR shank.

Tapping Systems and Accessories

HRF Reversible Tapping Attachments



FEATURES

Usable on every vertical drilling machine or machines with rotating non-reversing spindles

Right or left-hand tapping

Axial float ensures smooth tapping and better thread profile

Planetary gear reversing mechanism transmits smooth positive reverse to the tap for retraction at 75% faster speed than it enters

HR series used with rubber collets. HRF used with QC adapters

HRF Reversible Tapping Attachments

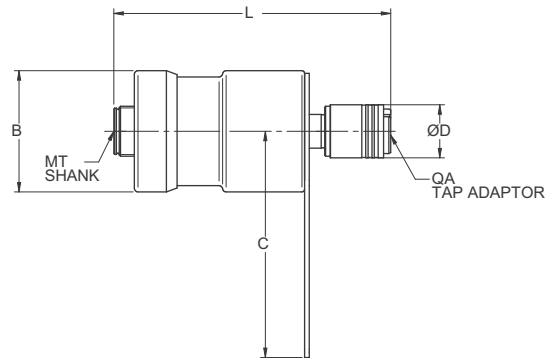

	Catalog Number	Description	Tap Size Range		Adaptor Size	Shank Size	L	ØB	ØD	ØC
			(inch)	(mm)						
Metric & INCH Shank	65291217	HRF1/ MT1	(1/16" - 1/4")	M1.4-M7	QA-0	JT33	6.69	2.17	0.91	4.06
	65301217	HRF1/ MT2	(1/16" - 1/4")	M1.4-M7	QA-0	JT33	6.69	2.17	0.91	4.06
	65302268	HRF2/ MT2	(1/8" - 1/2")	M3 -M12	QA-1	5/8"-16 UN	7.09	2.68	1.18	5.00
	65312268	HRF2/ MT3	(1/8" - 1/2")	M3 -M12	QA-1	5/8"-16 UN	7.09	2.68	1.18	5.00
	653025268	HRF2/ MT2	(1/8" - 1/2")	M3 -M12	QA-1	JT6	7.09	2.68	1.18	5.00
	653125268	HRF2/ MT3	(1/8" - 1/2")	M3 -M12	QA-1	JT6	7.09	2.68	1.18	5.00
	65313327	HRF3 MT3	(5/16" - 3/4")	M8 - M20	QA-40	M20 P2.5	7.48	3.27	1.65	6.57
	65323327	HRF3 MT4	(5/16" - 3/4")	M8 - M20	QA-40	M20 P2.5	7.87	3.27	1.65	6.57
	65324433	HRF4 MT4	(9/16" - 1-1/8")	M14 - M30	QA-3	M20 P2.5	8.66	4.33	2.83	10.55
	65334433	HRF4 MT5	(9/16" - 1-1/8")	M14 - M30	QA-3	M20 P2.5	8.66	4.33	2.83	10.55

Tap Adaptors on page 162-163

Tapping Systems and Accessories

HR Reversible Tapping Attachments

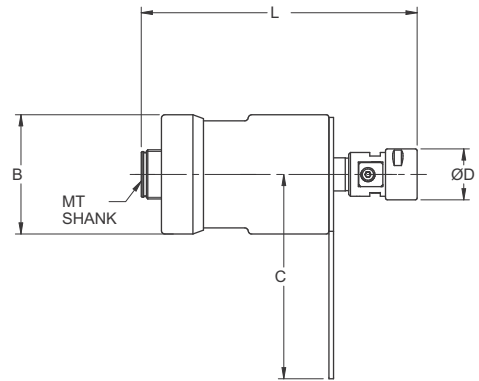

Metric & INCH Shank

Catalog Number	Description	Tap Size Range		Standard Collet		Optional Collet	Shank Size	L	ØB	ØD	ØC
		(mm)	(inch)								
61291217	HR1/ MT1	M1.4-M7	1/16"-1/4"	S-161 (2.5 - 4.5)	S-171 (4.5 - 6.5)	S-151 (1 - 2.5)	JT33	5.51	2.17	0.79	4.06
61301217	HR1/ MT2	M1.4-M7	1/16"-1/4"	S-161 (2.5 - 4.5)	S-171 (4.5 - 6.5)	S-151 (1 - 2.5)	JT33	5.91	2.17	0.79	4.06
61302268	HR2/ MT2	M3-M12	1/8"-1/2"	S-212 (3.5 - 6.5)	S-222 (6.5 - 10)	S-232 (2 - 4.5)	5/8"-16 UN	7.87	2.68	1.14	5.00
61312268	HR2/ MT3	M3-M12	1/8"-1/2"	S-212 (3.5 - 6.5)	S-222 (6.5 - 10)	S-232 (2 - 4.5)	5/8"-16 UN	8.66	2.68	1.14	5.00
613025268	HR2/ MT2	M3-M12	1/8"-1/2"	S-212 (3.5 - 6.5)	S-222 (6.5 - 10)	S-232 (2 - 4.5)	JT6	7.87	2.68	1.14	5.00
613125268	HR2/ MT3	M3-M12	1/8"-1/2"	S-212 (3.5 - 6.5)	S-222 (6.5 - 10)	S-232 (2 - 4.5)	JT6	8.66	2.68	1.14	5.00
61313327	HR3 MT3	M8-M20	5/16"-3/4"	S-413 (4.5 - 10)	S-453 (10 - 16)	S-433 (2.8 - 7)	M20 P2.5	9.06	3.27	1.49	6.57
61323327	HR3 MT4	M8-M20	5/16"-3/4"	S-413 (4.5 - 10)	S-453 (10 - 16)	S-433 (2.8 - 7)	M20 P2.5	9.45	3.27	1.49	6.57
61324433	HR4 MT4	M14-M30	9/16"-1-1/8"	S-613 (9 - 16)	S-623 (16 - 23)	-	M20 P2.5	10.43	4.33	2.03	10.55
61334433	HR4 MT5	M14-M30	9/16"-1-1/8"	S-613 (9 - 16)	S-623 (16 - 23)	-	M20 P2.5	11.02	4.33	2.03	10.55

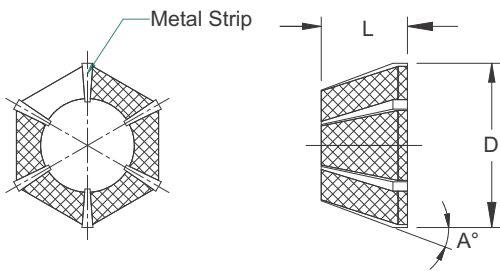

Rubber Collets for HR Tapping Heads

Catalog Number	Capacity (inch)	Capacity (mm)	Model Number	ØD	L	A°	# of Strips
S-151	0.047-0.094"	1.0 - 2.5	HR1	0.590	0.472	13°	3
S-161	0.094-0.177"	2.5 - 4.5	HR1	0.590	0.472	13°	6
S-171	0.177-0.256"	4.5 - 6.5	HR1	0.590	0.472	13°	8
S-212	0.139-0.257"	3.5 - 6.5	HR2	0.885	0.511	20°	6
S-222	0.253-0.383"	6.5 - 10	HR2	0.885	0.511	20°	6
S-232	0.090-0.180"	2.0 - 4.5	HR2	0.885	0.511	20°	6
S-413	0.176-0.383"	4.5 - 10.0	HR3	1.200	0.629	22° 30'	6
S-433	0.110-0.280"	2.8 - 7.0	HR3	1.200	0.629	22° 30'	4
S-453	0.393-0.590"	10.0-16.0	HR3	1.200	0.629	22° 30'	6
S-613	0.354-0.630"	9.0 - 16.0	HR4	1.848	0.748	25°	9
S-623	0.630-0.905"	16.0 - 23.0	HR4	1.848	0.748	25°	9

Tapping Systems and Accessories

SDG Self Opening Die - Head

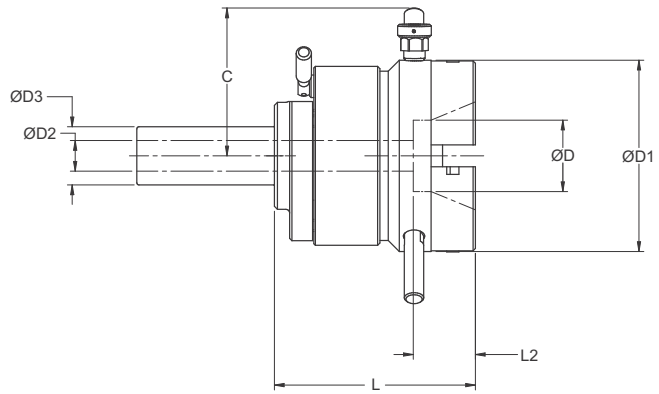

Metric & INCH Shank

Catalog Number	Description	Tap Size Range		ØD1 (inch)	ØD (inch)	C (inch)	L (inch)	L2 (inch)	Pipe (Inch)	Standard Shank	
		(inch)	(mm)							D3 (inch)	D2 (inch)
24158038	SDG-1	(3/32" - 5/16")	M2 - M8	1.77	0.49	1.89	2.11	0.94	—	0.625	0.375
24258038	SDG-2	(3/16" - 9/16")	M4 - M14	2.52	0.67	1.65	2.56	1.28	0.125 - 0.25	0.625	0.375
24234038										0.75	0.375
24210058										1.00	0.625
24334038	SDG-3	(1/4" - 3/4")	M6 - M18	3.46	0.98	2.20	3.46	1.81	0.125 - 0.5	0.75	0.375
24310005										1.00	0.5
24410005	SDG-4	(3/8" - 1")	M10 - M24	4.02	1.3	2.48	3.74	1.99	0.125 - 0.75	1.00	0.5
24415116										1.50	1.1666
24515875	SDG-5	(1/2" - 1 1/4")	M12 - M30	4.72	1.61	2.83	4.37	1.65	0.25 - 1	1.50	0.875
24520138										2.00	1.375

Tapping Systems and Accessories

Die Holder - Model DH

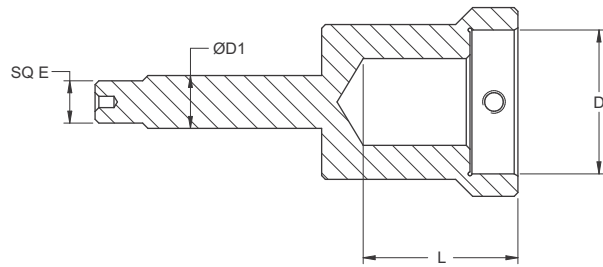

Catalog Number	Capacity	ϕD (inch)	$\phi D1$ (inch)	E (inch)	L (inch)
27812394	0.125 - 0.25	0.8125	0.394	0.315	1.378
27100394	0.125 - 0.25	1.00	0.394	0.315	1.378
27100492	0.25 - 0.375	1.00	0.492	0.394	1.496
27937551	0.25 - 0.563	0.937	0.551	0.441	1.575
27150551	0.375 - 0.75	1.50	0.551	0.441	1.575

Tap Chuck - Model TK / MT

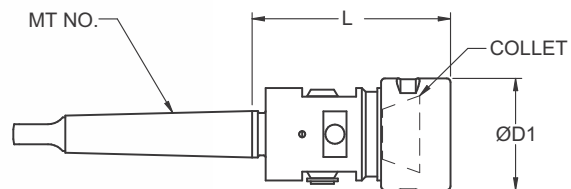

Catalog Number	Description	Suitable Collet	Capacity (inch)	ϕD (inch)	L Max. (inch)
30130177	TK1/MT2	S212	0.257 - 0.383	1.141	1.77
30131177	TK1/MT3	S-222 S-232	0.090 - 0.180		1.77
30230197	TK2/MT-2	S-413	0.180 - 0.383	1.496	1.968
30231197	TK2/MT-3	S-433	0.110 - 0.280		1.968
30232203	TK2/MT-4	S-453	0.383 - 0.630		2.027
30331341	TK3/MT-3	S-613 S-623	0.406 - 0.630	2.027	3.405
30332341	TK3/MT-4		3.405		
30333341	TK3/MT-5		3.405		

Rubber Collet on page 152

NOTE : Tap chuck model TK/MT are supplied without Rubber Collet.
If require order separately.

Tapping Systems and Accessories

Tap Chuck - Model TK / JT

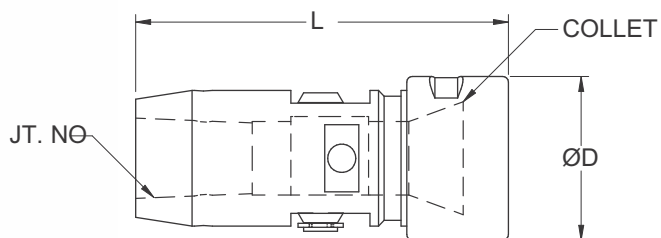

Catalog Number	Description	Suitable Collet	Capacity (inch)	ØD (inch)	L Max. (inch)
29011279	TK1/JT1	S212	0.139 - 0.257	1.141	2.795
29013295	TK1/JT2	S-222	0.257 - 0.383		2.952
29015256	TK1/JT6	S-232	0.090 - 0.180		2.559
29023315	TK2 / JT2	S-433	0.180 - 0.383	1.496	3.149
29027315	TK2/JT3	S-453	0.110 - 0.280		3.149
29025315	TK2/JT6	S-413	0.383 - 0.630		4.330
29037433	TK3/JT3	S-613	0.406 - 0.630	2.027	4.330
29038433	TK3/JT4	S-623	0.630 - 0.905		4.330

Rubber Collet **on page 152**

NOTE : Tap Chuck Model TK/JT are supplied without Rubber Collet. If require order separately.

Tapping Systems and Accessories

Tapping Chucks - Tension & Compression Style with High Pressure Coolant-Through - QCLC-IK



Modular Shanks W/ Weldon And Whistle Flats

	Catalog Number	Description	Tap Size Range	Adaptor Size	Length Composition		L (inch)	ØD1 (inch)	ØD (inch)
					Comp.	Expand.			
Metric Shank	C26331020	SSH25-QCLC-IK-115	#0-9/16	1	0.295	0.295	2.44	1.54	0.748
	C26332020	SSH25-QCLC-IK-220	1/4-7/8	2	0.492	0.492	3.86	2.36	1.220
	C26333030	SSH32-QCLC-IK-335	13/16-1-3/8	3	0.787	0.787	5.79	3.39	1.889
Inch Shank	C26511320	SSH1.00-QCLC-IK-115	#0-9/16	1	0.295	0.295	2.44	1.54	0.748
	C26512320	SSH1.00-QCLC-IK-220	1/4-7/8	2	0.492	0.492	3.86	2.36	1.220
	C26543320	SSH1.25-QCLC-IK-335	13/16-1-3/8	3	0.787	0.787	5.79	3.39	1.889

Tap Adapters on page 162-176

Taper Shank Adapters below

Modular Shank Holders

For Use with Modular Shank Tap Holders

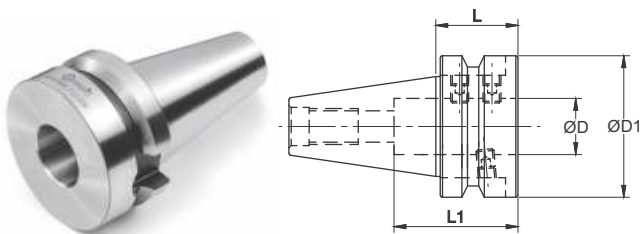

BT (MAS 403)

Suitable For Central Coolant Flow

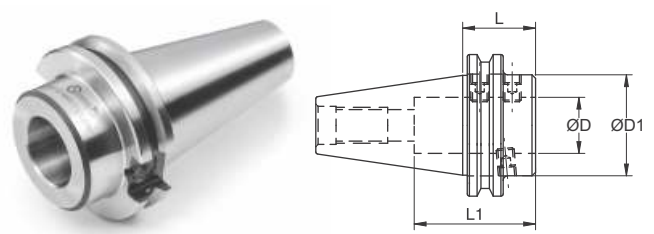

CAT (ASNI-ASME B5.50-1994)

Suitable For Central Coolant Flow

	Catalog Number	Description	Use with Modular Shank	ØD	L	L1	ØD1
Metric Bore	331225	BT40-MSH-25-35	MS25	25	35	54	63
	331432	BT50-MSH-32-35	MS32	32	35	61	69.9
	332425	CAT40-MSH-25-35	MS25	25	35	54	44.45
	332625	CAT50-MSH-25-35	MS25	25	35	54	69.9
	332632	CAT50-MSH-32-35	MS32	32	35	61	69.9
Inch Bore	331221	BT40-MSH-1.00-1.375	MS1.00	1.00	1.375	2.125	63
	331423	BT50-MSH-1.50-1.375	MS1.50	1.50	1.375	2.500	69.9
	332421	CAT40-MSH-1.00-1.375	MS1.00	1.00	1.375	2.125	44.45
	332621	CAT50-MSH-1.00-1.375	MS1.00	1.00	1.375	2.125	69.9
	332623	CAT50-MSH-1.50-1.375	MS1.50	1.50	1.375	2.500	69.9

Tapping Systems and Accessories

Tapping Chucks - Rigid Style with Coolant-Through - QCK-IK

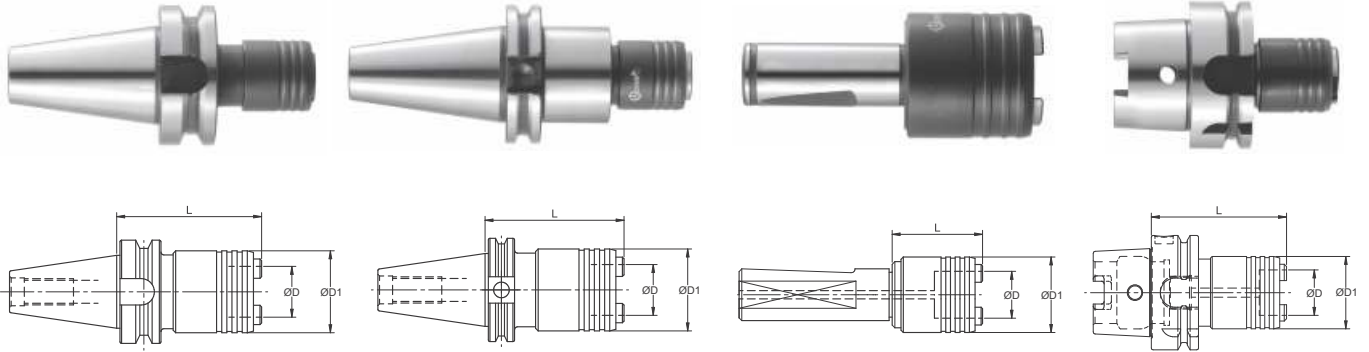

BT Style (MAS 403)

CAT Style
(ANSI/ASME B5.50-1994)

Straight Shank
W/ Modular Shank

HSK Style

	Catalog Number	Description	Tap Size Range	Adaptor Size	L (inch)	ØD1 (inch)	ØD (inch)
BT Shank	C13211010	BT30-QCK-IK 1	#0-9/16	1	2.640	1.25	0.748
	C13211020	BT40-QCK-IK 1	#0-9/16	1	2.834	1.25	0.748
	C13212020	BT40-QCK-IK 2	1/4-7/8	2	3.582	1.96	1.220
Cat Shank	C13221020	CAT40-QCK-IK 1	#0-9/16	1	3.15	1.25	0.748
	C13222020	CAT40-QCK-IK 2	1/4-7/8	2	3.15	1.96	1.220
	C13223020	CAT40-QCK-IK 3	13/16-1-3/8	3	4.33	2.83	1.889
	C13221040	CAT50-QCK-IK 1	#0-9/16	1	2.83	1.25	0.748
	C13222040	CAT50-QCK-IK 2	1/4-7/8	2	3.58	1.96	1.220
	C13223040	CAT50-QCK-IK 3	13/16-1-3/8	3	4.33	2.83	1.889
	C13224040	CAT50-QCK-IK 4	15/16-1-7/8	4	4.72	3.74	2.362
HSK Shank	C13271030	HSK50A-QCK-IK-1	#0-9/16	1	3.15	1.26	0.748
	C13272030	HSK50A-QCK-IK-2	1/4-7/8	2	3.94	1.97	1.220
	C13271040	HSK63A-QCK-IK-1	#0-9/16	1	3.35	1.26	0.748
	C13272040	HSK63A-QCK-IK-2	1/4-7/8	2	3.94	1.97	1.220
	C13271050	HSK80A-QCK-IK-1	#0-9/16	1	2.76	1.26	0.748
	C13272050	HSK80A-QCK-IK-2	1/4-7/8	2	3.64	1.97	1.220
	C13273050	HSK80A-QCK-IK-3	13/16-1-3/8	3	4.76	2.84	1.889
	C13271060	HSK100A-QCK-IK-1	#0-9/16	1	3.54	1.26	0.748
	C13272060	HSK100A-QCK-IK-2	1/4-7/8	2	4.33	1.97	1.220
C13273060	HSK100A-QCK-IK-3	13/16-1-3/8	3	5.91	2.84	1.889	
Straight Shank Modular	C13321100	SSH.750-QCK-IK-1	#0-9/16	1	1.574	1.41	0.748
	C13321130	SSH1.00-QCK-IK-1	#0-9/16	1	2.834	1.41	0.748
	C13322130	SSH1.00-QCK-IK-2	1/4-7/8	2	2.519	2.08	1.220
	C13323130	SSH1.00-QCK-IK-3	13/16-1-3/8	3	3.818	3.07	1.889
	C13321140	SSH1.25-QCK-IK-1	#0-9/16	1	2.834	1.41	0.748
	C13322140	SSH1.25-QCK-IK-2	1/4-7/8	2	2.519	2.08	1.220
	C13323140	SSH1.25-QCK-IK-3	13/16-1-3/8	3	3.818	3.07	1.889
	C13321180	SSH1.50-QCK-IK-1	#0-9/16	1	2.834	1.41	0.748
	C13322180	SSH1.50-QCK-IK-2	1/4-7/8	2	2.519	2.08	1.220
	C13323180	SSH1.50-QCK-IK-3	13/16-1-3/8	3	3.818	3.07	1.889
	C13324180	SSH1.50-QCK-IK-4	15/16-1-7/8	4	4.251	3.77	2.360

Tap Adapters on page 162-176

Tapping Systems and Accessories

Tapping Chucks - Tension & Compression Style - Non-Coolant Through - QCLK

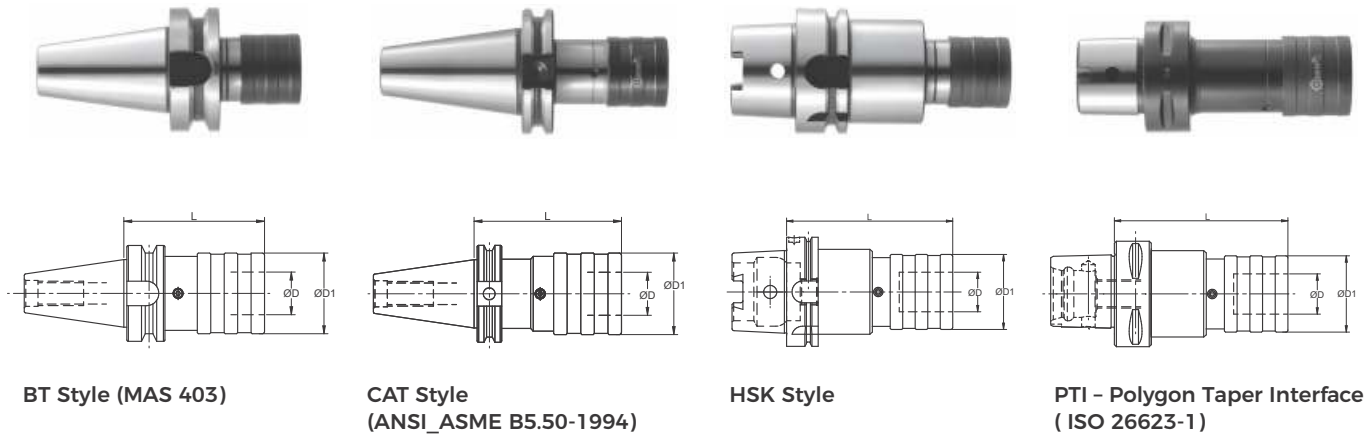

	Catalog Number	Description	Tap Size Range	Adaptor Size	Length Composition		L (inch)	ØD1 (inch)	ØD (inch)
					Comp.	Expand.			
CAT Shank	20221020	CAT40-QCLK-1	#0-9/16	1	0.295	0.295	2.97	1.42	0.748
	20222020	CAT40-QCLK-2	1/4-7/8	2	0.492	0.492	3.94	2.09	1.22
	20221040	CAT50-QCLK-1	#0-9/16	1	0.295	0.295	3.52	1.42	0.748
	20222040	CAT50-QCLK-2	1/4-7/8	2	0.492	0.492	4.04	2.09	1.22
	20223040	CAT50-QCLK-3	13/16-1-3/8	3	0.787	0.787	5.59	3.07	1.89
	20224040	CAT50-QCLK-4	1-1-7/8	4	0.886	0.886	6.52	3.78	2.36
BT Shank	20211010	BT30-QCLK 1	#0-9/16	1	0.295	0.295		1.42	0.748
	20211020	BT40-QCLK-1	#0-9/16	1	0.295	0.295	3.52	1.42	0.748
	20212020	BT40-QCLK-2	1/4-7/8	2	0.492	0.492	4.04	2.09	1.22
HSK Shank	26161030	HSK50A-QCLK-1	#0-9/16	1	0.295	0.295	4.10	1.417	0.748
	26162030	HSK50A-QCLK-2	1/4-7/8	2	0.492	0.492	5.51	2.086	1.22
	26161040	HSK63A-QCLK-1	#0-9/16	1	0.295	0.295	4.16	1.417	0.748
	26162040	HSK63A-QCLK-2	1/4-7/8	2	0.492	0.492	5.57	2.086	1.22
	26161050	HSK80A-QCLK-1	#0-9/16	1	0.295	0.295	4.36	1.417	0.748
	26162050	HSK80A-QCLK-2	1/4-7/8	2	0.492	0.492	5.77	2.086	1.22
	26163050	HSK80A-QCLK-3	13/16-1-3/8	3	0.787	0.787	8.39	3.07	1.889
	26161060	HSK100A-QCLK-1	#0-9/16	1	0.295	0.295	4.43	1.417	0.748
	26162060	HSK100A-QCLK-2	1/4-7/8	2	0.492	0.492	5.85	2.086	1.22
26163060	HSK100A-QCLK-3	13/16-1-3/8	3	0.787	0.787	8.46	3.07	1.889	
PTI Shank	20171660	PTI32-QCLK-1	#0-9/16	1	0.295	0.295	3.14	1.417	0.748
	20171680	PTI50-QCLK-1	#0-9/16	1	0.295	0.295	3.14	1.417	0.748
	20172680	PTI50-QCLK-2	1/4-7/8	2	0.492	0.492	4.53	2.086	1.22
	20171690	PTI63-QCLK-1	#0-9/16	1	0.295	0.295	3.54	1.417	0.748
	20172690	PTI63-QCLK-2	1/4-7/8	2	0.492	0.492	4.72	2.086	1.22
	20173690	PTI63-QCLK-3	13/16-1-3/8	3	0.787	0.787	6.69	3.07	1.889
	20171700	PTI80-QCLK-1	#0-9/16	1	0.295	0.295	3.35	1.417	0.748
	20172700	PTI80-QCLK-2	1/4-7/8	2	0.492	0.492	4.33	2.086	1.22
	20173700	PTI80-QCLK-3	13/16-1-3/8	3	0.787	0.787	6.30	3.07	1.889

Tap Adapters on page 162-176

Tapping Systems and Accessories

Tapping Chucks - Tension & Compression Style - Non-Coolant Through - QCLK

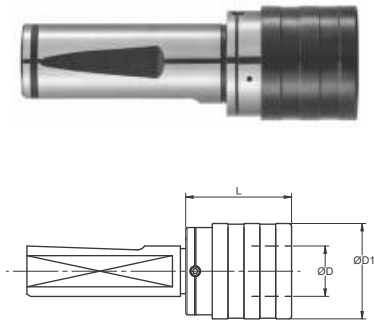

Straight Shank W/ Modular Shank

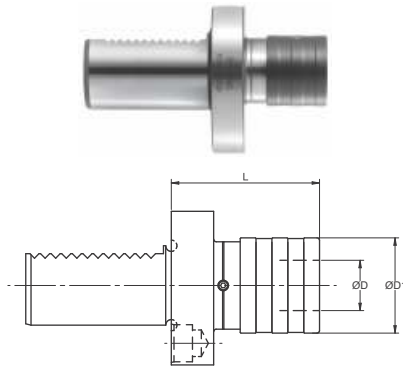

VDI Shank (VDI 3425/DIN 69880)

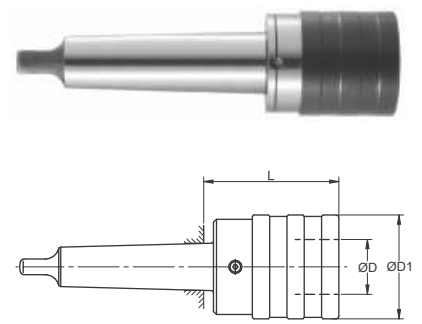

Morse Taper Style

	Catalog Number	Description	Tap Size Range	Adaptor Size	Length Composition		L (inch)	ØD1 (inch)	ØD (inch)
					Comp.	Expand.			
Straight Shank	20321100	SSH25-QCLK-1	#0-9/16	1	0.295	0.295	3.35	1.417	0.748
	20322100	SSH25-QCLK-2	1/4-7/8	2	0.492	0.492	4.33	2.086	1.22
	20321140	SSH32-QCLK-1	#0-9/16	1	0.295	0.295	3.35	1.417	0.748
	20322140	SSH32-QCLK-2	1/4-7/8	2	0.492	0.492	4.33	2.086	1.22
	20323140	SSH32-QCLK-3	13/16-1-3/8	3	0.787	0.787	6.30	3.07	1.889
	20321450	SSH.750-QCLK-1	#0-9/16	1	0.295	0.295	3.35	1.417	0.748
	20321130	SSH1.00-QCLK-1	#0-9/16	1	0.295	0.295	3.35	1.417	0.748
	20322130	SSH1.00-QCLK-2	1/4-7/8	2	0.492	0.492	4.33	2.086	1.22
	20321540	SSH1.25-QCLK-1	#0-9/16	1	0.295	0.295	3.35	1.417	0.748
	20322540	SSH1.25-QCLK-2	1/4-7/8	2	0.492	0.492	4.33	2.086	1.22
	20323540	SSH1.25-QCLK-3	13/16-1-3/8	3	0.787	0.787	6.30	3.07	1.889
20323180	SSH1.50-QCLK-3	13/16-1-3/8	3	0.787	0.787	6.30	3.07	1.889	
VDI Shank	20361000	VDI20-QCLK-1	#0-9/16	1	0.295	0.295	2.08	1.417	0.748
	20361010	VDI30-QCLK-1	#0-9/16	1	0.295	0.295	2.20	1.417	0.748
	20362010	VDI30-QCLK-2	1/4-7/8	2	0.492	0.492	3.03	2.086	1.22
	20361020	VDI40-QCLK-1	#0-9/16	1	0.295	0.295	2.20	1.417	0.748
	20362020	VDI40-QCLK-2	1/4-7/8	2	0.492	0.492	3.03	2.086	1.22
	20363020	VDI40-QCLK-3	13/16-1-3/8	3	0.787	0.787	4.85	3.07	1.889
	20361030	VDI50-QCLK-1	#0-9/16	1	0.295	0.295	2.20	1.417	0.748
	20362030	VDI50-QCLK-2	1/4-7/8	2	0.492	0.492	3.15	2.086	1.22
	20363030	VDI50-QCLK-3	13/16-1-3/8	3	0.787	0.787	4.30	3.07	1.889
	20364030	VDI50-QCLK-4	15/16 - 1-7/8	4	0.886	0.886	4.85	3.78	2.36
	20363040	VDI60-QCLK-3	13/16-1-3/8	3	0.787	0.787	4.30	3.07	1.889
20364040	VDI60-QCLK-4	15/16 - 1-7/8	4	0.886	0.886	4.75	3.78	2.36	
Morse Taper	20100020	MT2-QCLK-0	#0-1/4	0	0.255	0.255	1.77	1.03	0.512
	20101020	MT2-QCLK-1	#0-9/16	1	0.295	0.295	1.85	1.417	0.748
	20101030	MT3-QCLK-1	#0-9/16	1	0.295	0.295	1.85	1.417	0.748
	20102030	MT3-QCLK-2	1/4-7/8	2	0.492	0.492	2.79	2.086	1.22
	20102040	MT4-QCLK-2	1/4-7/8	2	0.492	0.492	2.83	2.086	1.22
	20103040	MT4-QCLK-3	13/16-1-3/8	3	0.787	0.787	4.13	3.07	1.889
	20103050	MT5-QCLK-3	13/16-1-3/8	3	0.787	0.787	4.15	3.07	1.889
	20104050	MT5-QCLK-4	15/16 - 1-7/8	4	0.886	0.886	4.58	3.78	2.36
	20105050	MT5-QCLK-5	1-1/16-2-3/4	5	1.181	1.181	7.18	5.12	3.07
	20104060	MT6-QCLK-4	15/16 - 1-7/8	4	0.886	0.886	4.66	3.78	2.36
	20105060	MT6-QCLK-5	1-1/16-2-3/4	5	1.181	1.181	6.47	5.12	3.07

Tap Adapters on page 162-176

Tapping Systems and Accessories

Tap Adapter Guide

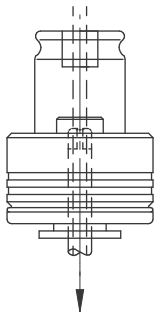
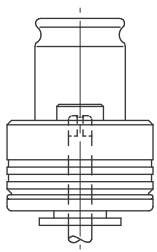
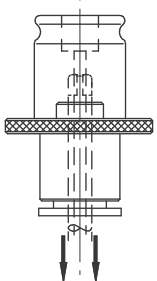
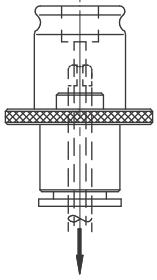
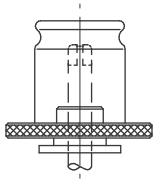

Style	Features	Coolant Style	Series Sizes	Inch Tap Range	NPT Tap Range	Metric Tap Range	Comments
QA	Quick Change	Non-Coolant	0 - 4	#0 - 1-3/8"	1/8" - 1"	3mm - 36mm	General Purpose - Use with Rigid or Tension/Compression style holders
QA-1K	Quick Change	Coolant Thru Tap	1 - 3	#0 - 1-3/8"	1/8" - 1"	3mm - 36mm	General Purpose - Use with Rigid or Tension/Compression style holders with taps that offer coolant thru tap
QA-K	Quick Change	Coolant Surround Tap	1 - 3	#0 - 1-3/8"	1/8" - 1"	3mm - 36mm	General Purpose - Use with Rigid or Tension/Compression style holders use with coolant thru holders where coolant surround the tap shank is desired.
QASB	Quick Change with Torque Control	Non-Coolant	0 - 5, 40	#0 - 2-3/4"	N/A	3mm - 36mm	General Purpose - Use with Tension/Compression style holders for through hole tapping or bottom tapping and in high nickel materials or material with Rc over 40 Rc
QASB-1K	Quick Change with Torque Control	Coolant Thru Tap	1 - 4	#0 - 1-3/8"	1/8" - 1"	3mm - 36mm	General Purpose - Use with Tension/Compression style holders for through hole tapping or bottom tapping and in high nickel materials or material with Rc over 40 Rc when using coolant through taps

Tapping Systems and Accessories

Tap Adapter Guide

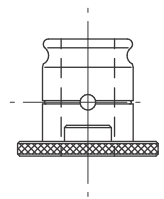
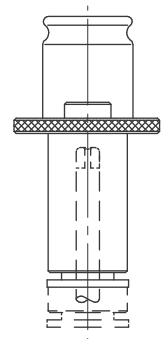
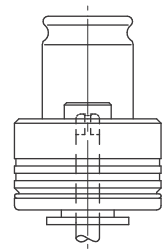
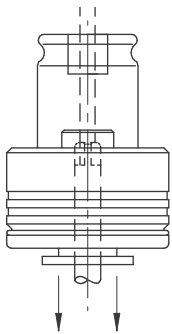

Style	Features	Coolant Style	Series Sizes	Inch Tap Range	NPT Tap Range	Metric Tap Range	Comments
QASB-K	Quick Change with Torque Control	Coolant Surround Tap	1 - 4	#0 - 1-3/8"	1/8" - 1"	3mm - 36mm	General Purpose - Use with Tension/Compression style holders for through hole tapping or bottom tapping and in high nickel materials or material with Rc over 40 Rc when coolant on the tap is desired but not coolant thru taps
QASPB	Quick Change with Torque Control for NPT Taps	Non-Coolant	2 - 5	N/A	1/8" - 3"	N/A	General Purpose - Use with Tension/Compression style holders for through hole tapping or bottom tapping and in high nickel materials or material with Rc over 40 Rc
QAN	Quick Change Extension with length adjustment	Non-Coolant	0 - 4	#0 - 1-3/8"	1/8" - 1"	3mm - 48mm	General Purpose - Use with Rigid or Tension/Compression style holders when additional piece part clearance and/or longer reach tapping applications are needed.
QRE	Quick Change Reducer	Coolant Thru	1 - 5	#0 - 1-3/8"	1/8" - 1"	3mm - 36mm	Use when you want to reduce tap adapter series within the current tap holder series in use.

Tapping Systems and Accessories

Tap Adapters QA Style – ANSI Shank Taps

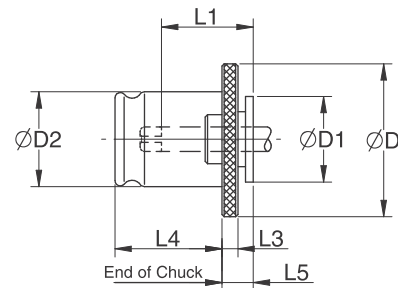

QA Style

Description	Tap Size Range		Dimension (mm/inch)						
	Inch	Metric	ϕD	$\phi D1$	$\phi D2$	L1	L3	L4	L5
QA 0	#0-5/16"	M1-M10	0.866	0.512	0.512	0.590	0.157	0.768	0.275
QA 1	#0-9/16"	M3-M12	1.181	0.748	0.748	0.669	0.157	0.846	0.275
QA 2	1/4"-7/8"	M8-M20	1.889	1.181	1.181	1.181	0.196	1.378	0.433
QA 3	13/16"-1-3/8"	M13-M33	2.755	1.889	1.889	1.732	0.236	2.185	0.551
QA 4	15/16"-1-7/8"	M22-M48	3.622	2.362	2.362	2.795	0.511	2.480	1.653

	Tap Size Range		Shank Dia. (inch)	Shank Sq. (inch)	Catalog Number				
	Inch	Metric			QA0	QA1	QA2	QA3	QA4
Hand Taps – ANSI Shank	#0 - #6	M3	0.141	0.110	40000104	40100104	40200104		
	#8, 5/32"	M4	0.168	0.131	40000148	40100148	40200148		
	#10, 3/16"	M4.5, M5	0.194	0.152	40000187	40100187	40200187		
	#12, 7/32"		0.220	0.165	40000212	40100212	40200212		
	#14, 1/4"	M6, M6.5	0.255	0.191	40000266	40100266	40200266		
	1/4" Sm	M6, M6.5	0.185	0.138	40000173	40100173	40200173		
	5/16"	M7, M8	0.318	0.238	40000324	40100324	40200324		
	3/8"	M10	0.381	0.286		40100386	40200386		
	7/16"		0.323	0.242		40100330	40200330		
	1/2"	M12, M12.5	0.367	0.275		40100366	40200366		
	9/16"	M14	0.429	0.322		40100402	40200402		
	5/8"	M16	0.480	0.360			40200435		
	11/16"	M18	0.542	0.406			40200460		
	3/4"		0.590	0.442			40200481		
	13/16"	M20	0.652	0.489			40200505	40300505	
	7/8"	M22	0.697	0.523			40200516	40300516	
	15/16"	M24	0.760	0.570				40300550	40400550
1"	M25	0.800	0.600				40300564	40400564	
1-1/8"		0.896	0.672				40300588	40400588	
1-1/4"	M30	1.021	0.766				40300625	40400625	
1-3/8"	M33	1.108	0.831				40300662	40400662	
Pipe Taps – ANSI Shank	1/8"NPT	SM. Shank	0.313	0.234	40000305	40100305	40200305		
	1/8"NPT	Lg. Shank	0.437	0.328		40100412	40200412		
	1/4"NPT		0.562	0.421			40200476		
	3/8"NPT		0.700	0.531			40200521	40300521	
	1/2"NPT		0.687	0.515			40200510	40300510	
	3/4"NPT		0.906	0.679				40300596	40400596
	1"NPT		1.125	0.843				40300669	40400669

Tapping Systems and Accessories

Tap Adapters QA Style – DIN Shank Taps

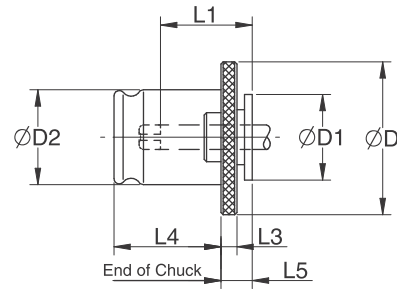

QA Style

Description	Tap Size Range		Dimension (mm/inch)						
	Inch	Metric	ØD	ØD1	ØD2	L1	L3	L4	L5
QA 0	#0-5/16"	M1-M10	0.866	0.512	0.512	0.590	0.157	0.768	0.275
QA 1	#0-9/16"	M3-M12	1.181	0.748	0.748	0.669	0.157	0.846	0.275
QA 2	1/4"-7/8"	M8-M20	1.889	1.181	1.181	1.181	0.196	1.378	0.433
QA 3	13/16"-1-3/8"	M13-M33	2.755	1.889	1.889	1.732	0.236	2.185	0.551
QA 4	15/16"-1-7/8"	M22-M48	3.622	2.362	2.362	2.795	0.511	2.480	1.653

	Size (Metric)		Shank Dia. (mm)	Shank Sq. (mm)	Catalog Number				
	DIN 371	DIN 376			QA0	QA1	QA2	QA3	QA4
Hand Taps – ANSI Shank	M3		3.5	2.7	40000091				
	M4		4.5	3.4	40000151	40100151	40200151		
	M5		6.0	4.9	40000232	40100232	40200232		
	M6		6.0	4.9	40000232	40100232	40200232		
	M7		7.0	5.5		40100274	40200274		
	M8		8.0	6.2	40000310	40100310	40200310		
		M8	6.0	4.9	40000232	40100232	40200232		
	M10		10.0	8.0	40000389	40100389	40200389		
		M10	7.0	5.5	40000274	40100274	40200274		
		M12	9.0	7.0		40100348	40200348		
		M14	11.0	9.0			40200408	40300408	
		M16	12.0	9.0			40200430	40300430	
		M18	14.0	11.0			40200465	40300465	
		M20	16.0	12.0			40200491	40300491	
		M22	18.0	14.5				40300531	40400531
		M24	18.0	14.5				40300531	40400531
		M27	20.0	16.0				40300556	40400556
		M30	22.0	18.0				40300578	40400578
		M33	25.0	20.0				40300615	40400615
		M36	28.0	22.0					40400645
	M39	32.0	24.0					40400698	
	M42	32.0	24.0					40400698	
	M45	36.0	29.0					40400734	
	M48	36.0	29.0					40400734	

Tapping Systems and Accessories

Tap Adapters QA/IK Style - Inch Shank Taps

With Coolant Through the Tap Flow

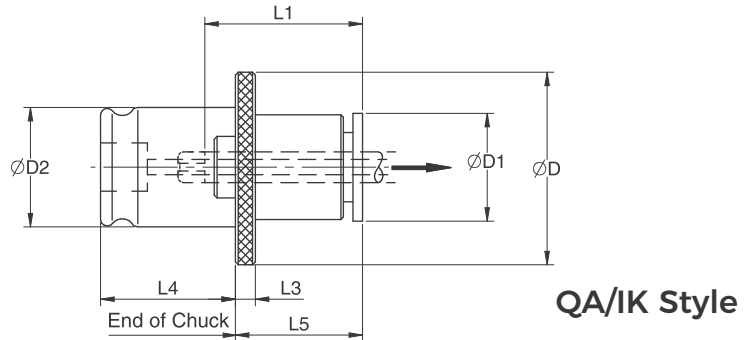

Description	Tap Size Range		Dimension (mm/inch)						
	Inch	Metric	ØD	ØD1	ØD2	L1	L3	L4	L5
QA-IK 1	#0-9/16"	M3-M12	1.181	0.748	0.748	0.669	0.157	0.846	0.680
QA-IK 2	1/4"-7/8"	M8-M20	1.890	1.181	1.220	1.181	0.196	1.378	1.230
QA-IK 3	13/16"-1-3/8"	M14-M33	2.760	1.889	1.889	1.732	0.236	2.185	1.600

	Size		Shank Dia. (inch)	Shank Sq. (inch)	Catalog Number		
	Inch	Metric			QA/IK 1	QA/IK 2	QA/IK 3
Hand Taps - ANSI Shank	#0 - #6	M3	0.141	0.110	A40100104	A40200104	
	#8	M4	0.168	0.131	A40100148	A40200148	
	#10	M4.5, M5	0.194	0.152	A40100187	A40200187	
	#12		0.220	0.165	A40100212	A40200212	
	1/4"	M6, M6.5	0.255	0.191	A40100266	A40200266	
	1/4" Sm	M6, M6.5	0.185	0.138	A40100173	A40200173	
	5/16"	M7, M8	0.318	0.238	A40100324	A40200324	
	3/8"	M10	0.381	0.286	A40100386	A40200386	
	7/16"		0.323	0.242	A40100330	A40200330	
	1/2"	M12, M12.5	0.367	0.275	A40100366	A40200366	
	9/16"	M14	0.429	0.322	A40100402	A40200402	
	5/8"	M16	0.480	0.360		A40200435	
	11/16"	M18	0.542	0.406		A40200460	
	3/4"		0.590	0.442		A40200481	
	13/16"	M20	0.652	0.489		A40200505	A40300505
	7/8"	M22	0.697	0.523		A40200516	A40300516
	15/16"	M24	0.760	0.570			A40300550
	1"	M25	0.800	0.600			A40300564
	1-1/8"		0.896	0.672			A40300588
1-1/4"	M30	1.021	0.766			A40300625	
1-3/8"	M33	1.108	0.831			A40300662	

	Size		Shank Dia. (inch)	Shank Sq. (inch)	Catalog Number		
	Inch NPT				QA/IK 1	QA/IK 2	QA/IK 3
Pipe Taps - ANSI Shank	1/8"NPT	SM. Shank	0.313	0.234	A40100305		
	1/8"NPT	Lg. Shank	0.437	0.328	A40100412	A40200412	
	1/4"NPT		0.562	0.421		A40200476	
	3/8"NPT		0.700	0.531		A40200521	A40300521
	1/2"NPT		0.687	0.515		A40200510	A40300510
	3/4"NPT		0.906	0.679			A40300596
	1"NPT		1.125	0.843			A40300669

Tapping Systems and Accessories

Tap Adapters QA/IK Style – Metric Shank Taps

With Coolant Through the Tap Flow

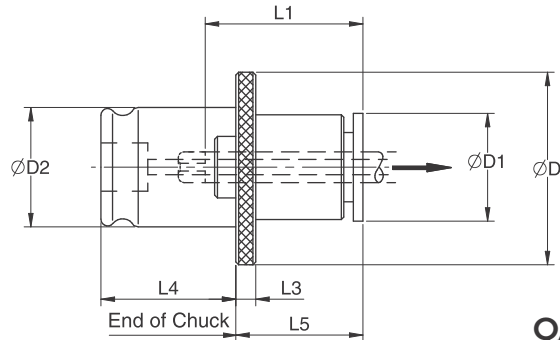

QA/IK Style

	Size (Metric)		Shank Dia. (mm)	Shank Sq. (mm)	Catalog Number		
	DIN 371	DIN 376			QA/IK 1	QA/IK 2	QA/IK 3
Hand Taps – DIN Shank	M3		3.5	2.7	A40100091		
	M4		4.5	3.4	A40100151	A40200151	
	M5		6.0	4.9	A40100232	A40200232	
	M6		6.0	4.9	A40100232	A40200232	
	M7		7.0	5.5	A40100274	A40200274	
	M8		8.0	6.2	A40100310	A40200310	
	M10	M8	6.0	4.9	A40100232	A40200232	
			10.0	8.0	A40100389	A40200389	
		M10	7.0	5.5	A40100274	A40200274	
		M12	9.0	7.0	A40100348	A40200348	
		M14	11.0	9.0	A40100408	A40200408	A40300408
		M16	12.0	9.0		A40200430	A40300430
		M18	14.0	11.0		A40200465	A40300465
		M20	16.0	12.0		A40200491	A40300491
		M22	18.0	14.5			A40300531
		M24	18.0	14.5			A40300531
		M27	20.0	16.0			A40300556
		M30	22.0	18.0			A40300578
	M33	25.0	20.0			A40300615	
	M36	28.0	22.0			A40300645	

Did you know?

Over the past 25 years, U.S.-manufactured goods exports have quadrupled. In 1990, for example, U.S. manufacturers exported \$329.5 billion in goods. By 2000, that number had more than doubled to \$708.0 billion. In 2014, it reached an all-time high, for the fifth consecutive year, of \$1.403 trillion, despite slowing global growth.

U.S. Commerce Department via. nam.org

Tapping Systems and Accessories

Tap Adapters QA/K Style – Inch Shank Taps

With Coolant Surround the Tap Flow

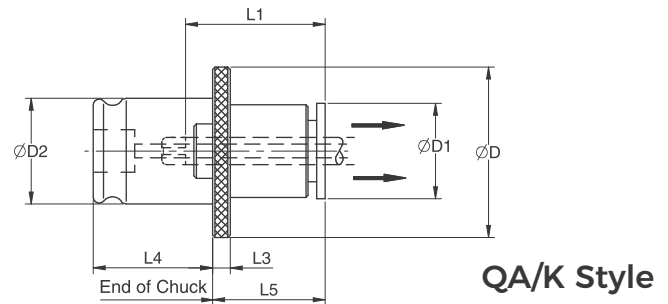

QA/K Style

Description	Tap Size Range		Dimension (mm/inch)						
	Inch	Metric	ϕD	$\phi D1$	$\phi D2$	L1	L3	L4	L5
QA/K 1	#0-9/16"	M3-M12	1.181	0.748	0.748	0.669	0.157	0.846	0.275
QA/K 2	1/4"-7/8"	M8-M20	1.890	1.181	1.220	1.181	0.196	1.378	0.433
QA/K 3	13/16"-1-3/8"	M14-M33	2.760	1.889	1.889	1.732	0.236	2.185	0.551

	Size		Shank Dia. (inch)	Shank Sq. (inch)	Catalog Number		
	Inch	Metric			QA/K 1	QA/K 2	QA/K 3
Hand Taps - ANSI Shank	#0 - #6	M3	0.141	0.110	B40100104	B40200104	
	#8	M4	0.168	0.131	B40100148	B40200148	
	#10	M4.5, M5	0.194	0.152	B40100187	B40200187	
	#12		0.220	0.165	B40100212	B40200212	
	1/4"	M6, M6.5	0.255	0.191	B40100266	B40200266	
	1/4" Sm	M6, M6.5	0.185	0.138	B40100173	B40200173	
	5/16"	M7, M8	0.318	0.238	B40100324	B40200324	
	3/8"	M10	0.381	0.286	B40100386	B40200386	
	7/16"		0.323	0.242	B40100330	B40200330	
	1/2"	M12, M12.5	0.367	0.275	B40100366	B40200366	
	9/16"	M14	0.429	0.322	B40100402	B40200402	
	5/8"	M16	0.480	0.360		B40200435	
	11/16"	M18	0.542	0.406		B40200460	
	3/4"		0.590	0.442		B40200481	
	13/16"	M20	0.652	0.489		B40200505	B40300505
	7/8"	M22	0.697	0.523		B40200516	B40300516
	15/16"	M24	0.760	0.570			B40300550
	1"	M25	0.800	0.600			B40300564
1-1/8"		0.896	0.672			B40300588	
1-1/4"	M30	1.021	0.766			B40300625	
1-3/8"	M33	1.108	0.831			B40300662	

	Size		Shank Dia. (inch)	Shank Sq. (inch)	Catalog Number		
	Inch NPT				QA/K 1	QA/K 2	QA/K 3
Pipe Taps - ANSI Shank	1/8"NPT	SM. Shank	0.313	0.234	B40100305		
	1/8"NPT	Lg. Shank	0.437	0.328	B40100412	B40200412	
	1/4"NPT		0.562	0.421		B40200476	
	3/8"NPT		0.700	0.531		B40200521	B40300521
	1/2"NPT		0.687	0.515		B40200510	B40300510
	3/4"NPT		0.906	0.679			B40300596
	1"NPT		1.125	0.843			B40300669

Tapping Systems and Accessories

Tap Adapters QA/K Style – Metric Shank Taps

With Coolant Surround the Tap Flow

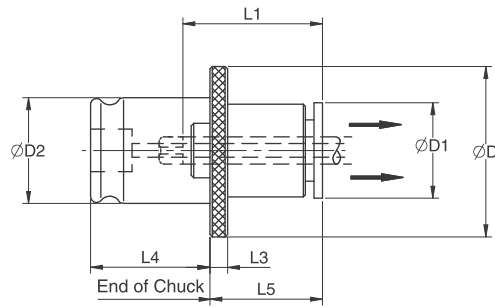

QA/K Style

	Size (Metric)		Shank Dia. (mm)	Shank Sq. (mm)	Catalog Number		
	DIN 371	DIN 376			QA/K 1	QA/K 2	QA/K 3
Hand Taps - DIN Shank	M3		3.5	2.7	B40100091		
	M4		4.5	3.4	B40100151	B40200151	
	M5		6.0	4.9	B40100232	B40200232	
	M6		6.0	4.9	B40100232	B40200232	
	M7		7.0	5.5	B40100274	B40200274	
	M8		8.0	6.2	B40100310	B40200310	
		M8	6.0	4.9	B40100232	B40200232	
	M10		10.0	8.0	B40100389	B40200389	
		M10	7.0	5.5	B40100274	B40200274	
		M12	9.0	7.0	B40100348	B40200348	
		M14	11.0	9.0	B40100408	B40200408	B40300408
		M16	12.0	9.0		B40200430	B40300430
		M18	14.0	11.0		B40200465	B40300465
		M20	16.0	12.0		B40200491	B40300491
		M22	18.0	14.5			B40300531
		M24	18.0	14.5			B40300531
		M27	20.0	16.0			B40300556
	M30	22.0	18.0			B40300578	
	M33	25.0	20.0			B40300615	
	M36	28.0	22.0			B40300645	

Tapping Systems and Accessories

Tap Adapters QASB Style - Inch Shank Taps

Without Coolant and with Safety Clutch

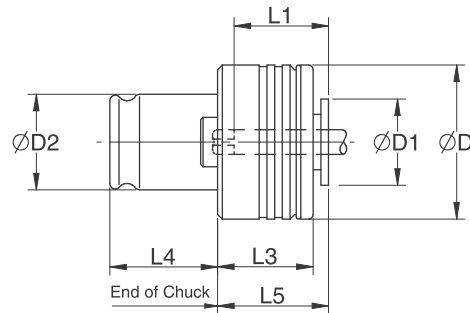

QASB Style

Description	Tap Size Range		Dimension (mm/inch)						
	Inch	Metric	ØD	ØD1	ØD2	L1	L3	L4	L5
QASB 1	#0-9/16"	M3-M12	1.259	0.748	0.748	0.669	0.984	0.846	0.984
QASB 2	1/4"-7/8"	M8-M20	1.968	1.181	1.220	1.181	1.220	1.377	1.338
QASB 3	13/16"-1-3/8"	M14-M33	2.834	1.889	1.889	1.732	1.614	2.185	1.771
QASB-4	15/16"-1-7/8"	M22-M48	3.740	2.362	2.362	2.795	2.401	2.480	2.677

	Size		Shank Dia. (inch)	Shank Sq. (inch)	Catalog Number			
	Inch	Metric			QASB-1	QASB-2	QASB-3	QASB-4
Hand Taps - ANSI Shank	#0 - #6	M3	0.141	0.110	41100104	41200104		
	#8	M4	0.168	0.131	41100148	41200148		
	#10	M4.5, M5	0.194	0.152	41100187	41200187		
	#12		0.220	0.165	41100212	41200212		
	1/4"	M6, M6.5	0.255	0.191	41100266	41200266		
	5/16"	M7, M8	0.318	0.238	41100324	41200324		
	3/8"	M10	0.381	0.286	41100386	41200386		
	7/16"		0.323	0.242	41100330	41200330		
	1/2"	M12, M12.5	0.367	0.275	41100366	41200366		
	9/16"	M14	0.429	0.322	41100402	41200402		
	5/8"	M16	0.480	0.360		41200435		
	11/16"	M18	0.542	0.406		41200460		
	3/4"		0.590	0.442		41200481		
	13/16"	M20	0.652	0.489		41200505	41300505	
	7/8"	M22	0.697	0.523		41200516	41300516	
	15/16"	M24	0.760	0.570			41300550	41400550
	1"	M25	0.800	0.600			41300564	41400564
	1-1/8"		0.896	0.672			41300588	41400588
1-1/4"	M30	1.021	0.766			41300625	41400625	
1-3/8"	M33	1.108	0.831			41300662	41400662	

	Size		Shank Dia. (inch)	Shank Sq. (inch)	Catalog Number		
	Inch NPT				QASB-1	QASB-2	QASB-3
Pipe Taps - ANSI Shank	1/8"NPT	SM. Shank	0.313	0.234	41100305		
	1/8"NPT	Lg. Shank	0.437	0.328	41100412	41200412	
	1/4"NPT		0.562	0.421		41200476	
	3/8"NPT		0.700	0.531		41200521	41300521
	1/2"NPT		0.687	0.515		41200510	41300510
	3/4"NPT		0.906	0.679			41300596
	1"NPT		1.125	0.843			41300669

GWA Style Pin Wrench on page 177

Tapping Systems and Accessories

Tap Adapters QASB Style – Metric Shank Taps

Without Coolant and with Safety Clutch

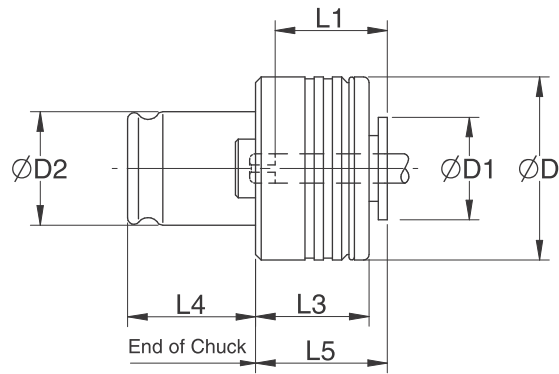

QASB Style

Description	Tap Size Range		Dimension (mm/inch)						
	Inch	Metric	ØD	ØD1	ØD2	L1	L3	L4	L5
QASB 1	#0-9/16"	M3-M12	1.259	0.748	0.748	0.669	0.984	0.846	0.984
QASB 2	1/4"-7/8"	M8-M20	1.968	1.181	1.220	1.181	1.220	1.377	1.338
QASB 3	13/16"-1-3/8"	M14-M33	2.834	1.889	1.889	1.732	1.614	2.185	1.771
QASB-4	15/16"-1-7/8"	M22-M48	3.740	2.362	2.362	2.795	2.401	2.480	2.677

Size (Metric)		Shank Dia. (mm)	Shank Sq. (mm)	Catalog Number			
DIN 371	DIN 376			QASB-1	QASB-2	QASB-3	QASB-4
M3		3.5	2.7	41100091			
M4		4.5	3.4	41100151			
M5		6.0	4.9	41100232	41200232		
M6		6.0	4.9	41100232	41200232		
M7		7.0	5.5	41100274	41200274		
M8		8.0	6.2	41100310	41200310		
	M8	6.0	4.9	41100232	41200232		
M10		10.0	8.0	41100389	41200389		
		7.0	5.5	41100274	41200274		
	M12	9.0	7.0		41200348		
	M14	11.0	9.0		41200408	41300408	
	M16	12.0	9.0		41200430	41300430	
	M18	14.0	11.0		41200465	41300465	
	M20	16.0	12.0		41200491	41300491	
	M22	18.0	14.5			41300531	41400531
	M24	18.0	14.5			41300531	41400531
	M27	20.0	16.0			41300556	41400556
	M30	22.0	18.0			41300578	41400578
	M33	25.0	20.0			41300615	41400615
	M36	28.0	22.0			41300645	41400645

GWA Style Pin Wrench on page 177

Tapping Systems and Accessories

Tap Adapters QASB-K Style – Inch Shank Taps

With Surround Coolant Flow and Safety Clutch

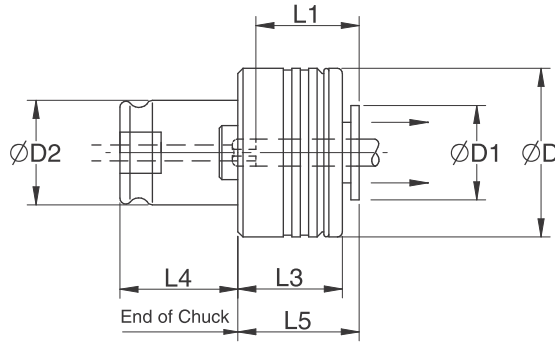

QASB/K Style

Description	Tap Size Range		Dimension (mm/inch)						
	Inch	Metric	ØD	ØD1	ØD2	L1	L3	L4	L5
QASB-K 1	#0-9/16"	M3-M12	1.259	0.748	0.748	0.669	0.984	0.846	0.984
QASB-K 2	1/4"-7/8"	M8-M20	1.968	1.181	1.220	1.181	1.220	1.377	1.338
QASB-K 3	13/16"-1-3/8"	M14-M33	2.834	1.889	1.889	1.732	1.614	2.185	1.771
QASB-K 4	15/16"-1-7/8"	M22-M48	3.740	2.362	2.362	2.795	2.401	2.480	2.677

	Size		Shank Dia. (inch)	Shank Sq. (inch)	Catalog Number			
	Inch	Metric			QASB-K 1	QASB-K 2	QASB-K 3	QASB-K 4
Hand Taps – ANSI Shank	#0 - #6	M3	0.141	0.110	B41100104	B41200104		
	#8	M4	0.168	0.131	B41100148	B41200148		
	#10	M4.5, M5	0.194	0.152	B41100187	B41200187		
	#12		0.220	0.165	B41100212	B41200212		
	1/4"	M6, M6.5	0.255	0.191	B41100266	B41200266		
	5/16"	M7, M8	0.318	0.238	B41100324	B41200324		
	3/8"	M10	0.381	0.286	B41100386	B41200386		
	7/16"		0.323	0.242	B41100330	B41200330		
	1/2"	M12, M12.5	0.367	0.275	B41100366	B41200366		
	9/16"	M14	0.429	0.322	B41100402	B41200402		
	5/8"	M16	0.480	0.360		B41200435		
	11/16"	M18	0.542	0.406		B41200460		
	3/4"		0.590	0.442		B41200481		
	13/16"	M20	0.652	0.489		B41200505	B41300505	
	7/8"	M22	0.697	0.523		B41200516	B41300516	
	15/16"	M24	0.760	0.570			B41300550	B41400550
	1"	M25	0.800	0.600			B41300564	B41400564
	1-1/8"		0.896	0.672			B41300588	B41400588
1-1/4"	M30	1.021	0.766			B41300625	B41400625	
1-3/8"	M33	1.108	0.831			B41300662	B41400662	

	Size		Shank Dia. (inch)	Shank Sq. (inch)	Catalog Number		
	Inch NPT				QASB/K 1	QASB/K 2	QASB/K 3
Pipe Taps – ANSI Shank	1/8"NPT	SM. Shank	0.313	0.234	B41100305		
	1/8"NPT	Lg. Shank	0.437	0.328	B41100412	B41200412	
	1/4"NPT		0.562	0.421		B41200476	
	3/8"NPT		0.700	0.531		B41200521	B41300521
	1/2"NPT		0.687	0.515		B41200510	B41300510
	3/4"NPT		0.906	0.679			B41300596
	1"NPT		1.125	0.843			B41300669

GWA Style Pin Wrench on page 177

Tapping Systems and Accessories

Tap Adapters QASB-K Style- Metric Shank Taps

With Surround Coolant Flow and Safety Clutch

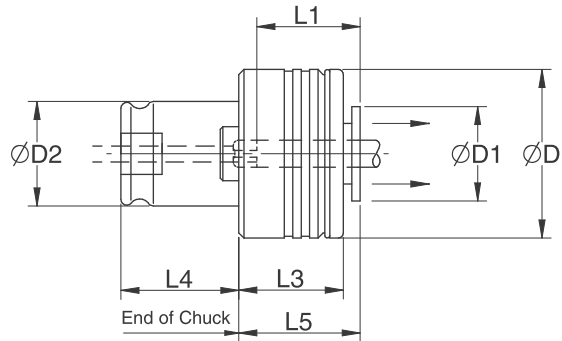

QASB/K Style

	Size (Metric)		Shank Dia. (mm)	Shank Sq. (mm)	Catalog Number				
	DIN 371	DIN 376			QASB-K 1	QASB-K 2	QASB-K 3	QASB-K 4	
Hand Taps - DIN Shank	M3		3.5	2.7	B41100091				
	M4		4.5	3.4	B41100151	B41200151			
	M5		6.0	4.9	B41100232	B41200232			
	M6		6.0	4.9	B41100232	B41200232			
	M7		7.0	5.5	B41100274	B41200274			
	M8		8.0	6.2	B41100310	B41200310			
	M10	M8	6.0	4.9	B41100232	B41200232			
			10.0	8.0	B41100389	B41200389			
		M10	M10	7.0	5.5	B41100274	B41200274		
			M12	9.0	7.0		B41200348		
			M14	11.0	9.0		B41200408	B41300408	
			M16	12.0	9.0		B41200430	B41300430	
			M18	14.0	11.0		B41200465	B41300465	
			M20	16.0	12.0		B41200491	B41300491	
			M22	18.0	14.5			B41300531	B41400531
			M24	18.0	14.5			B41300531	B41400531
			M27	20.0	16.0			B41300556	B41400556
M30			22.0	18.0			B41300578	B41400578	
M33	25.0	20.0			B41300615	B41400615			
M36	28.0	22.0			B41300645	B41400645			

GWA Style Pin Wrench on page 177

Tapping Systems and Accessories

Tap Adapters QASB-IK Style - Inch Shank Taps

With Coolant Flow and Safety Clutch

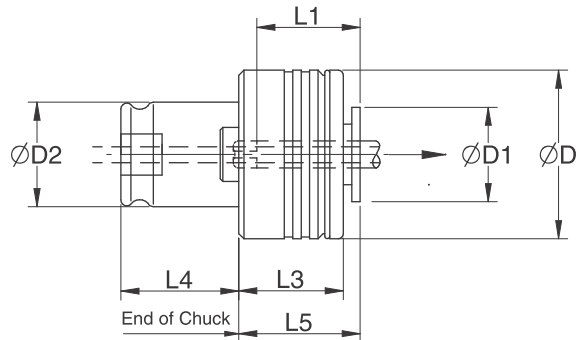

QASB-IK Style

Description	Tap Size Range		Dimension (mm/inch)						
	Inch	Metric	ØD	ØD1	ØD2	L1	L3	L4	L5
QASB-IK 1	#0-9/16"	M3-M12	1.259	0.748	0.748	0.669	0.984	0.846	0.984
QASB-IK 2	1/4"-7/8"	M8-M20	1.968	1.181	1.220	1.181	1.220	1.377	1.338
QASB-IK 3	13/16"-1-3/8"	M14-M33	2.834	1.889	1.889	1.732	1.614	2.185	1.771
QASB-IK 4	15/16"-1-7/8"	M22-M48	2.760	3.740	2.362	2.795	2.401	2.480	2.677

	Size		Shank Dia. (inch)	Shank Sq. (inch)	Catalog Number		
	Inch	Metric			QASB/IK 1	QASB/IK 2	QASB/IK 3
Hand Taps - ANSI Shank	#0 - #6	M3	0.141	0.110	A41100104	A41200104	
	#8	M4	0.168	0.131	A41100148	A41200148	
	#10	M4.5, M5	0.194	0.152	A41100187	A41200187	
	#12		0.220	0.165	A41100212	A41200212	
	1/4"	M6, M6.5	0.255	0.191	A41100266	A41200266	
	1/4" Sm	M6, M6.5	0.185	0.138	A41100173	A41200173	
	5/16"	M7, M8	0.318	0.238	A41100310	A41200310	
	3/8"	M10	0.381	0.286	A41100386	A41200386	
	7/16"		0.323	0.242	A41100330	A41200330	
	1/2"	M12, M12.5	0.367	0.275	A41100366	A41200366	
	9/16"	M14	0.429	0.322	A41100402	A41200402	
	5/8"	M16	0.480	0.360		A41200435	
	11/16"	M18	0.542	0.406		A41200460	
	3/4"		0.590	0.442		A41200481	
	13/16"	M20	0.652	0.489		A41200505	A41300505
	7/8"	M22	0.697	0.523		A41200516	A41300516
	15/16"	M24	0.760	0.570			A41300550
	1"	M25	0.800	0.600			A41300564
	1-1/8"		0.896	0.672			A41300588
1-1/4"	M30	1.021	0.766			A41300625	
1-3/8"	M33	1.108	0.831			A41300662	

	Size		Shank Dia. (inch)	Shank Sq. (inch)	Catalog Number		
	Inch NPT				QASB/IK 1	QASB/IK 2	QASB/IK 3
Pipe Taps - ANSI Shank	1/8"NPT	SM. Shank	0.313	0.234	A41100305		
	1/8"NPT	Lg. Shank	0.437	0.328	A41100412	A41200412	
	1/4"NPT		0.562	0.421		A41200476	
	3/8"NPT		0.700	0.531		A41200521	
	1/2"NPT		0.687	0.515		A41200510	A41300510
	3/4"NPT		0.906	0.679			A41300596
	1"NPT		1.125	0.843			A41300669

GWA Style Pin Wrench on page 177

Tapping Systems and Accessories

Tap Adapters QASB-IK Style - Metric Shank Taps

With Coolant Flow and Safety Clutch

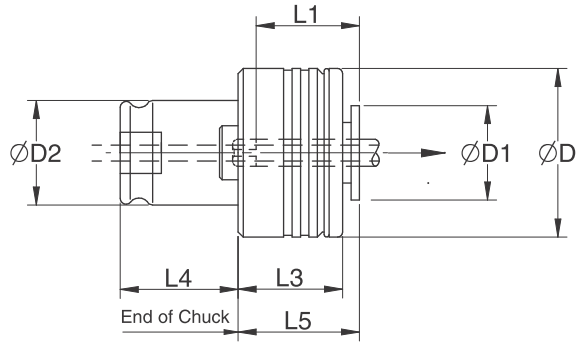

QASB-IK Style

	Size (Metric)		Shank Dia. (mm)	Shank Sq. (mm)	Catalog Number				
	DIN 371	DIN 376			QASB-IK 1	QASB-IK 2	QASB-IK 3	QASB-IK 4	
Hand Taps - DIN Shank	M3		3.5	2.7	A41100091				
	M4		4.5	3.4	A41100151	A41200151			
	M5		6.0	4.9	A41100232	A41200232			
	M6		6.0	4.9	A41100232	A41200232			
	M7		7.0	5.5	A41100274	A41200274			
	M8		8.0	6.2	A41100310	A41200310			
	M10	M8	6.0	4.9	A41100232	A41200232			
			10.0	8.0	A41100389	A41200389			
		M10	M10	7.0	5.5	A41100274	A41200274		
			M12	9.0	7.0	A41100348	A41200348		
			M14	11.0	9.0		A41200408	A41300408	
			M16	12.0	9.0		A41200430	A41300430	
			M18	14.0	11.0		A41200465	A41300465	
			M20	16.0	12.0		A41200491	A41300491	
			M22	18.0	14.5			A41300531	A41400531
	M24	18.0	14.5			A41300531	A41400531		
	M27	20.0	16.0			A41300556	A41400556		
M30	22.0	18.0			A41300578	A41400578			
M33	25.0	20.0			A41300615	A41400615			
M36	28.0	22.0				A41400645			

GWA Style Pin Wrench on page 177

Did you know?

Manufacturers in the United States perform more than three-quarters of all private-sector research and development (R&D) in the nation, driving more innovation than any other sector.

R&D in the manufacturing sector has risen from \$126.2 billion in 2000 to \$229.9 billion in 2014. In the most recent data, pharmaceuticals accounted for nearly one-third of all manufacturing R&D, spending \$74.9 billion in 2014. Aerospace, chemicals, computers, electronics and motor vehicles and parts were also significant contributors to R&D spending in that year.

nam.org

Tapping Systems and Accessories

Tap Adapters QAN Style - Inch Shank Taps

With Length Adjust

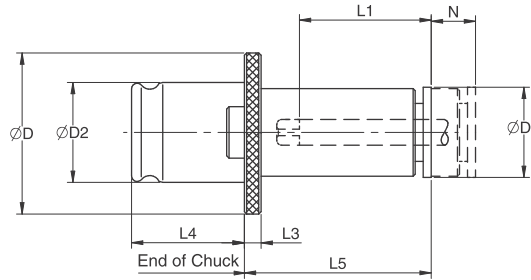

QAN Style

Description	Tap Size Range		Dimension (mm/inch)							
	Inch	Metric	N	ØD	ØD1	ØD2	L1	L3	L4	L5
QAN 0	#0-5/16"	M1-M10	0.32	0.87	0.512	0.512	0.59	0.157	0.767	1.141
QAN 1	#0-9/16"	M3-M12	0.39	1.181	0.748	0.748	0.669	0.157	0.846	1.338
QAN 2	1/4"-7/8"	M8-M20	0.59	1.889	1.181	1.220	1.181	0.196	1.377	2.362
QAN 3	13/16"-1-3/8"	M13-M33	0.984	2.755	1.889	1.889	1.732	0.236	2.185	3.267
QAN 4	15/16"-1-7/8"	M22-M48	1.574	3.622	2.362	2.362	2.795	0.520	2.480	5.390

	Size		Shank Dia. (inch)	Shank Sq. (inch)	Catalog Number				
	Inch	Metric			QAN 0	QAN 1	QAN 2	QAN 3	QAN 4
Hand Taps - ANSI Shank	#0 - #6	M3	0.141	0.110	48000104	48100104	48200104		
	#8, 5/32"	M4	0.168	0.131	48000148	48100148	48200148		
	#10, 3/16"	M4.5, M5	0.194	0.152	48000187	48100187	48200187		
	#12, 7/32"		0.220	0.165	48000212	48100212	48200212		
	1/4", #14	M6, M6.5	0.255	0.191	48000266	48100266	48200266		
	1/4" Sm	M6, M6.5	0.185	0.138	48000173	48100173	48200173		
	5/16"	M7, M8	0.318	0.238	48000324	48100324	48200324		
	3/8"	M10	0.381	0.286	48000386	48100386	48200386		
	7/16"		0.323	0.242	48000330	48100330	48200330		
	1/2"	M12, M12.5	0.367	0.275	48000366	48100366	48200366		
	9/16"	M14	0.429	0.322	48000402	48100402	48200402		
	5/8"	M16	0.480	0.360			48200435		
	11/16"	M18	0.542	0.406			48200460		
	3/4"		0.590	0.442			48200481		
	13/16"	M20	0.652	0.489			48200505	48300505	
	7/8"	M22	0.697	0.523			48200516	48300516	
	15/16"	M24	0.760	0.570				48300550	48400550
	1"	M25	0.800	0.600				48300564	48400564
1-1/8"		0.896	0.672				48300588	48400588	
1-1/4"	M30	1.021	0.766				48300625	48400625	
1-3/8"	M33	1.108	0.831				48300662	48400662	

	Size		Shank Dia. (inch)	Shank Sq. (inch)	Catalog Number				
	Inch	Metric			QAN 0	QAN 1	QAN 2	QAN 3	QAN 4
Pipe Taps - ANSI Shank	1/8"NPT	SM. Shank	0.313	0.234	48000305	48100305	48200305		
	1/8"NPT	Lg. Shank	0.437	0.328	48000412	48100412	48200412		
	1/4"NPT		0.562	0.421		48100460			
	3/8"NPT		0.700	0.531		48100521		48300521	
	1/2"NPT		0.687	0.515		48100510		48300510	
	3/4"NPT		0.906	0.679					48400596
	1"NPT		1.125	0.843					48400669

Tapping Systems and Accessories

Tap Adapters QAN Style - Metric Shank Taps

With Length Adjust

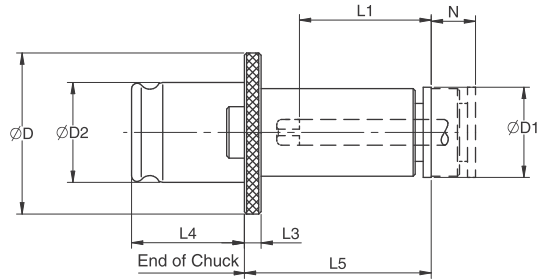

QAN Style

	Size		Shank Dia. (mm)	Shank Sq. (mm)	Catalog Number				
	Inch	Metric			QAN 0	QAN 1	QAN 2	QAN 3	QAN 4
Hand Taps - DIN Shank		M3	3.5	2.7	48000091				
		M4	4.5	3.4	48000151	48100151	48200151		
		M5	6.0	4.9	48000232	48100232	48200232		
		M6	6.0	4.9	48000232	48100232	48200232		
		M7	7.0	5.5		48100274	48200274		
		M8	8.0	6.2	48000310	48100310	48200310		
		M8	6.0	4.9	48000232	48100232	48200232		
		M10	10.0	8.0	48000389	48100389	48200389		
		M10	7.0	5.5	48000274	48100274	48200274		
		M12	9.0	7.0		48100348	48200348		
		M14	11.0	9.0			48200408	48300408	
		M16	12.0	9.0			48200430	48300430	
		M18	14.0	11.0			48200465	48300465	
		M20	16.0	12.0			48200491	48300491	
		M22	18.0	14.5				48300531	48400531
		M24	18.0	14.5				48300531	48400531
		M27	20.0	16.0				48300556	48400556
		M30	22.0	18.0				48300578	48400578
		M33	25.0	20.0				48300615	48400615
		M36	28.0	22.0					48400645
	M39	32.0	24.0					48400698	
	M42	32.0	24.0					48400698	
	M45	36.0	29.0					48400734	
	M48	36.0	29.0					48400734	

Tapping Systems and Accessories

Tap Adapter QRE Style

For Reduction from Larger Tap Adapter to Smaller Tap Adapter

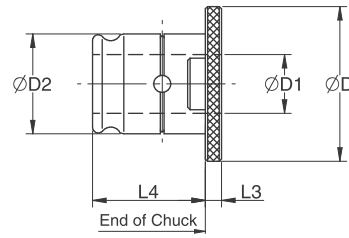

QRE Style

Catalog Number	Description	Suitable for Chuck Size	Adapter Size	Dimension (inch)				
				ØD	ØD1	ØD2	L3	L4
66100000	QRE 1/0	1	0	1.181	0.51	0.74	0.15	0.84
66200000	QRE 2/0	2	0	1.889	0.51	1.22	0.19	1.37
66200100	QRE 2/1	2	1	1.889	0.74	0.122	0.19	1.37
66300100	QRE 3/1	3	1	2.755	0.74	1.88	0.23	2.18
66300200	QRE 3/2	3	2	2.755	1.22	1.88	0.23	2.18
66400200	QRE 4/2	4	2	3.622	1.22	2.36	0.51	2.48
66400300	QRE 4/3	4	3	3.622	1.88	2.36	0.51	2.48
66500300	QRE 5/3	5	3	4.488	1.88	3.07	0.51	3.62
66500400	QRE 5/4	5	4	4.488	2.36	3.07	0.51	3.62

Adapter QA Jacob Taper Holder

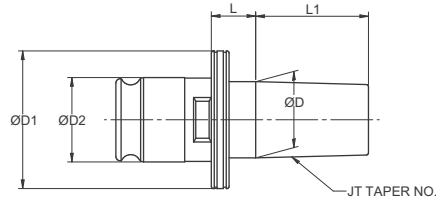

Catalog Number	Description	JT Taper No.	Dimension (mm)				
			L	L1	ØD	ØD1	ØD2
884401102	QA1-JTA 1-10	1	10.00	16.67	9.754	31.00	19.00
884401202	QA1-JTA 2-10	2	10.00	22.22	14.199	31.00	19.00
884401302	QA1-JTA 3-10	3	10.00	30.96	20.559	31.00	19.00
884401602	QA1-JTA 6-10	6	10.00	25.40	17.170	31.00	19.00
8844013302	QA1-JTA 33-10	33	10.00	25.40	15.850	31.00	19.00

Adapter QA Thread Holder

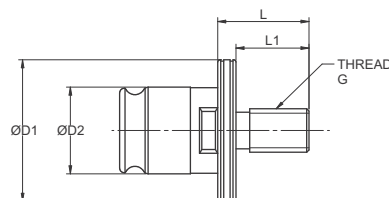

Catalog Number	Description	Dimension (mm)				
		L	L1	ØD1	ØD2	G
88640120604	QA1-THREAD 3/8"-16	20.00	16.00	31.00	19.00	3/8"-16
88640120704	QA1-THREAD 3/8"-24	20.00	16.00	31.00	19.00	3/8"-24
88640120804	QA1-THREAD 1/2"-20	20.00	16.00	31.00	19.00	1/2"-20

Tapping Systems and Accessories

GWA Style Pin Wrench



For turning the threaded ring of Torque style adapters.

Adaptor Size	GWA Size	Catalog Number
0	GWA-0	912000
1	GWA-1	912100
2	GWA-2	912200
3	GWA-3	912300
4	GWA-4	912400
5	GWA-5	912500

Tap Adapter Sets



	Catalog Number	Description	Adapter Size	Tap Sizes Included
Rigid Adapters (QA)	S40100010	QA1 Tap Adapter 10pc set	1	0-6, 8, 10, 12, 14 & ¼", 5/16", LS 3/8", 7/16", ½", 9/16"
	TS40100010-1	QA1 Tap Adapter 10pc set with 1" T/C Tapping Chuck (QCLK-1)		
	RS40100010-1	QA1 Tap Adapter 10pc set with 1" Rigid Tapping Chuck (QCK-1)		
	S40200013	QA2 Tap Adapter 13pc set	2	S401, TS401, RS 401 sets
	TS40200013-1	QA2 Tap Adapter 13pc set with 1" T/C Tapping Chuck (QCLK-2)		
	RS40200013-1	QA2 Tap Adapter 13pc set with 1" Rigid Tapping Chuck (QCK-1)		
	S40200018	QA2 Tap Adapter 18pc set	2	0-6, 8, 10, 12, 14 & ¼", 5/16", LS 3/8", 7/16", ½", 9/16", 5/8", 11/16", ¾", 13/16", 7/8", ¼" Pipe, 3/8" Pipe, ½" Pipe
	S40300009	QA3 Tap Adapter 9pc set	3	13/16", 7/8", 15/16", 1", 1-1/8", 1-1/4", 1-3/8", ¾" Pipe, 1" Pipe
	TS40300009-1.5	QA3 Tap Adapter 9pc set with 1.5" T/C Tapping Chuck (QCLK-3)		
RS40300009-1.5	QA3 Tap Adapter 9pc set with 1.5" Rigid Tapping Chuck (QCLK-3)			
Adapters with Clutch (QASB)	S41100010	QASB1 Torque Style Tap Adapter 10pc Set	1	0-6, 8, 10, 12, 14 & ¼", 5/16", LS 3/8", 7/16", ½", 9/16"
	TS41100010-1	QASB1 Torque Style Tap Adapter 10pc Set with 1" T/C Tapping Chuck		
	S41200012	QASB2 Torque Style Tap Adapter 12pc Set	2	0-6, 8, 10, 12, 14 & ¼", 5/16", LS 3/8", 7/16", ½", 9/16", 1/8" SS Pipe, 1/8" LS Pipe
	TS41200012-1	QASB2 Torque Style Tap Adapter 12pc Set with 1" T/C Tapping Chuck		

Note: High Precision (HP) Sets available

Tapping Systems and Accessories

AccuTap™ ERT/E ER

ER Tapping Collet with Quick Change feature and Axial Compensation



Features of AccuTap™ System:

✓ **High Quality**

Made using ISO 9001-2008 quality process standards

✓ **Compact**

Same quality that an ER collet and a QA tap adapter have but now designed into a sole product for use in small places (Swiss machining), Short gauge length confinements (Swiss machining), and shorter overall gauge length of tool assembly for high rigidity. Excellent for minimal clearance applications and machines with limited tooling clearances.

✓ **Interchangeable**

Can be used in any ER collet holder that conforms to ER DIN 6499/ISO 15488 standard
Can be used in ER 16 through ER40 collet chucks

✓ **Robust Design**

Features quality tempered spring for proper tension based on each individual tap size. Compensates for machine feed and tap pitch variances. Designed for high torque drive which ensures the same accuracy as the tap itself. Positive drive of tap using square internal to design of collet.

✓ **Cost Reduction Product**

Consolidate tooling setups with less tapping system products required. Quick change front-end design allows for tap changes without removing collet nut and collet for tap replacement. Simply depress tap button and tap is released for new tap to be inserted back into the collet.

Applications of AccuTap™ System:

- Axial float with tension control for CNC milling and turning machines with reversible spindles and where rigid tapping is desired.
- Blind hole and through hole tapping applications

Tapping Systems and Accessories

Simple to use and program:

- 1 Enter feed rate according to thread pitch (or 1-2% lower). Set spindle to starting point with 0.08 clearance.
- 2 Start spindle forward with right hand rotation until reaching desired depth.
- 3 Stop feed and rotation and reverse to starting point.

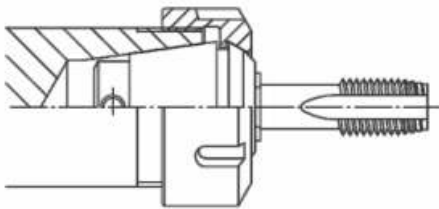
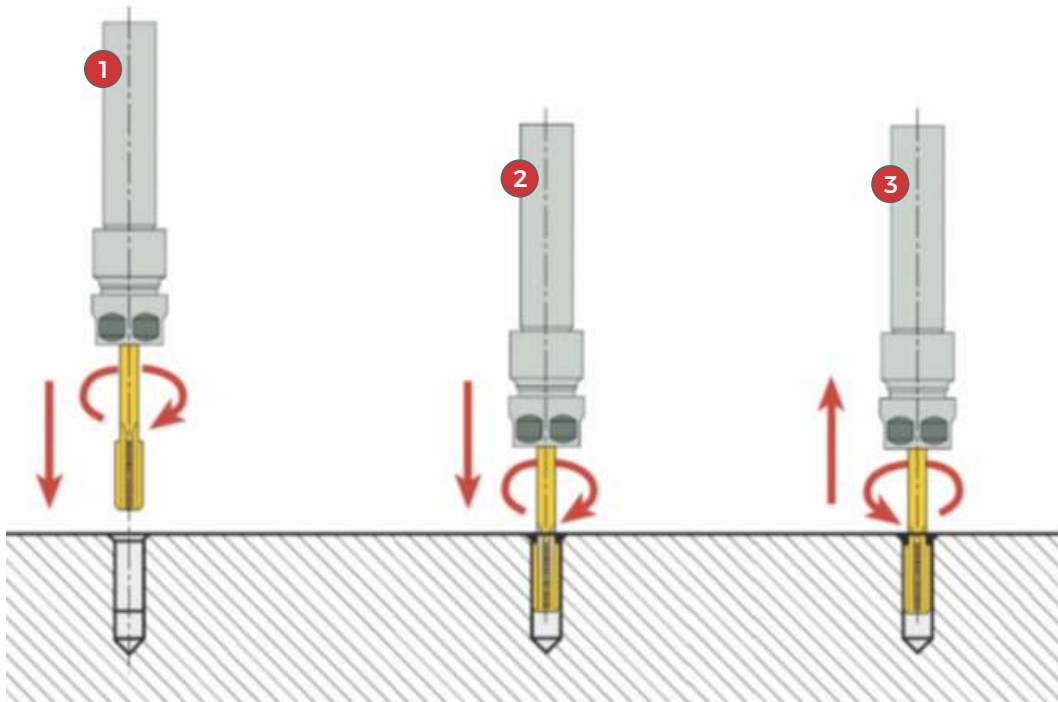

AccuTap™ ERT/E Tapping collets with axial compensation are a cost-effective tool holding Tapping option when producing threads in a piece part using a metal cutting tap. 100% thread profile from first thread to last thread. Increased tap life due to cutting action of tap is not compromised between programming and machining “micro-errors”.

Directions for Proper Use:

For tapping cycle, program the tap feed rate at 95% of the tap thread pitch value. This will allow 20%-25% of the tension compensation stroke to be used when the spindle rotation and spindle feed movement are simultaneously reversed.

On the reverse feed, program tap feed rate at 100% of the tap thread pitch value to allow the tension compensation to let the tap cut the exact thread pitch profile that the tap is ground to for all threads through the entire tapped hole. The tension stroke varies based on collet size and tap size. The tension spring is designed for each individual tap shank size to allow for proper tension compensation of each tap.

AccuTap™ ERT/E can be used at high RPM machining however some balance compensation may be required for inertia difference between spindle and feed movement.

Coolant through can be used if a maximum of 15 Bar or 200 psi coolant pressure is not exceeded. Exceeding this limit may cause coolant pressure to move tap in an axial position.

Tapping Systems and Accessories

ERT/E ER Quick Change Tap Collets with Square Drive and Axial Compensation

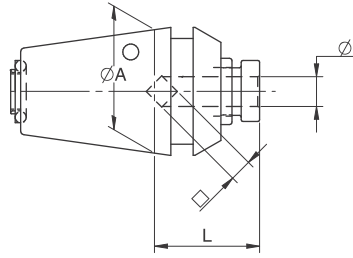

Model	Tension	A (mm)	L (mm)
ERT/E-16	7.00mm	16	21
ERT/E-20	7.50mm	20	24
ERT/E-25	8.00mm	25	24
ERT/E-32	10.00mm	32	27.5
ERT/E-40	12.00mm	40	34.5

	Shank (inch)	Square (inch)	Tap Size	ERT/E-16	ERT/E-20	ERT/E-25	ERT/E-32	ERT/E-40
Inch size (ANSI Shanks and Squares)	0.141	0.110	#0-#6	E95510104	E95520104	E95530104	E95540104	E95550104
	0.168	0.131	#8	E95510148	E95520148	E95530148	E95540148	E95550148
	0.194	0.152	#10, 3/16	E95510187	E95520187	E95530187	E95540187	E95550187
	0.220	0.165	#12		E95520212	E95530212	E95540212	E95550212
	0.255	0.191	1/4"		E95520266	E95530266	E95540266	E95550266
	0.318	0.238	5/16"			E95530324	E95540324	E95550324
	0.381	0.286	3/8"			E95530386	E95540386	E95550386
	0.323	0.242	7/16"			E95530330	E95540330	E95550330
	0.367	0.275	1/2"			E95530366	E95540366	E95550366
	0.429	0.322	9/16"				E95540402	E95550402
	0.480	0.360	5/8"				E95540435	E95550435
	0.542	0.406	11/16"				---	E95550460
	0.590	0.442	3/4"				---	E95550481
	0.437	0.328	1/8" NPT			---	E95540412	E95550412
	0.562	0.421	1/4" NPT					E95550476
0.542	0.406	3/8" NPT					E95550460	
	Shank (mm)	Square (mm)	Tap Size	ERT/E-16	ERT/E-20	ERT/E-25	ERT/E-32	ERT/E-40
Metric sizes (DIN Shanks and Squares)	3.50	2.7	M4 DIN 376	E95510038	E95520038	E95530038	E95540038	E95550038
	3.50	2.7	M3 DIN 371	E95510091	E95520091	E95530091	E95540091	E95550091
	4.00	3.0	M3.5 DIN 371	E95510121	E95520121	E95530121	E95540121	E95550121
	6.00	4.9	M5 DIN 371	E95510232	E95520232	E95530232	E95540232	E95550232
	4.50	3.4	M4 DIN 371	E95510151	E95520151	E95530151	E95540151	E95550151
	6.00	4.9	M6 DIN 371	E95510232	E95520232	E95530232	E95540232	E95550232
	6.00	4.9	M8 DIN 376		E95520232	E95530232	E95540232	E95550232
	7.00	5.5	M10 DIN 376		E95520274	E95530274	E95540274	E95550274
	8.00	6.2	M8 DIN 371			E95530310	E95540310	E95550310
	9.00	7.0	M12			E95530348	E95540348	E95550348
	10.00	8.0	M10 DIN 371				E95540389	E95550389
	11.00	9.0	M14				E95540408	E95550408
	12.00	9.0	M16				E95540430	E95550430
	14.00	11.0	M18					E95550465
	16.00	12.0	M20					E95550491

	Catalog Number	Description	Collet Size	Accommodates Tap Size Range
Inch Taps	E9551-SET	ERTE-16 SET (3pcs.)	ER16	#0 - #10
	E9552-SET	ERTE-20 SET (5pcs.)	ER20	#0 - 1/4"
	E9553-SET	ERTE-25 SET (9pcs.)	ER25	#0 - 7/16", 1/8NPT
	E9554-SET	ERTE-32 SET (12pcs.)	ER32	#0-5/8, 1/8NPT-1/4NPT
	E9555-SET	ERTE-40 SET (16pcs.)	ER40	#0-3/4, 1/8NPT-3/8NPT
Metric Taps	E9551M-SET	ERTE-16M SET (5pcs.)	ER16	M3-M6
	E9552M-SET	ERTE-20M SET (7pcs.)	ER20	M3-M10
	E9553M-SET	ERTE-25M SET (9pcs.)	ER25	M3-M12
	E9554M-SET	ERTE-32M SET (12pcs.)	ER32	M3-M16
	E9555M-SET	ERTE-40M SET (14pcs.)	ER4	M3-M20

Hardware and Accessories

Morse Taper Sockets and Extensions

RS And ES Styles

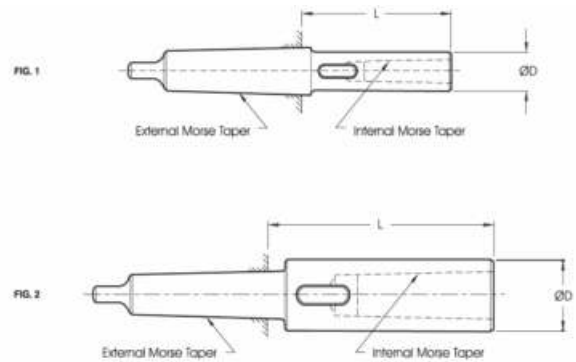
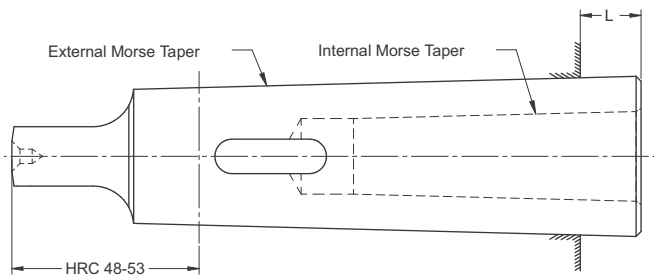

RS Style

ES Style

Catalog Number	Description	Morse Taper		L
		External	Internal	
212100	RS 21	2	1	0.670
213100	RS 31	3	1	0.200
213200	RS 32	3	2	0.710
214100	RS 41	4	1	0.260
214200	RS 42	4	2	0.260
214300	RS 43	4	3	0.890
215100	RS 51	5	1	0.260
215200	RS 52	5	2	0.260
215300	RS 53	5	3	0.260
215400	RS 54	5	4	0.850
216100	RS 61	6	1	0.315
216200	RS 62	6	2	0.315
216300	RS 63	6	3	0.315
216400	RS 64	6	4	0.315
216500	RS 65	6	5	0.315

Catalog Number	Description	Morse Taper		Fig #	ØD	L
		External	Internal			
201100	ES 11	1	1	2	0.79	3.27
201200	ES 12	1	2	2	1.18	3.86
202100	ES 21	2	1	2	1.18	3.34
202200	ES 22	2	2	2	0.79	3.94
202300	ES 23	2	3	2	1.42	4.76
203100	ES 31	3	1	1	0.79	3.19
203200	ES 32	3	2	2	1.18	3.94
203300	ES 33	3	3	2	1.42	4.76
203400	ES 34	3	4	2	1.89	5.83
204100	ES 41	4	1	1	0.79	3.25
204200	ES 42	4	2	1	1.18	3.84
204300	ES 43	4	3	2	1.42	4.82
204400	ES 44	4	4	2	1.89	5.81
204500	ES 45	4	5	2	2.48	7.18
205100	ES 51	5	1	1	0.79	3.25
205200	ES 52	5	2	1	1.18	3.83
205300	ES 53	5	3	1	1.42	4.67
205400	ES 54	5	4	2	1.89	5.90
205500	ES 55	5	5	2	2.48	7.30
206100	ES 61	5	1	1	0.79	3.30
206200	ES 62	6	2	1	1.18	3.90
206300	ES 63	6	3	1	1.42	4.72
206400	ES 64	6	4	1	1.89	5.71
206500	ES 65	6	5	1	2.48	7.10

Hardware and Accessories

ER Collets- Standard, High Precision, and Steel Sealed Collets - Inch and Metric ID Sizes

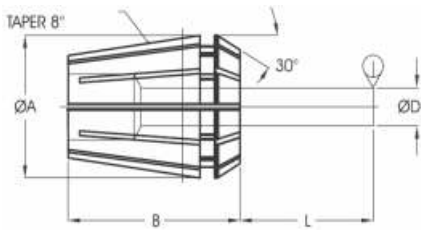

Collet Dimensions			Collet Accuracy					
ER Size	A	B	L Range	ØD Range	Standard	Premium	DIN 6499	Micro Precision
8	0.335	0.531	0.60	.120-.235	0.0004	0.0002	0.0006	.0001
11	0.452	0.710	1.00	.236-.393	0.0004	0.0002	0.0006	.0001
16	0.669	1.060	1.50	.393-.708	0.0004	0.0002	0.0006	.0001
20	0.826	1.220	2.00	.708-1.023	0.0004	0.0002	0.0006	.0001
25	1.023	1.380	2.25	1.023-1.340			0.0010	.0001
32	1.299	1.570						
40	1.614	1.810						

Accutek Micro-Precision available on request



Standard ER Collet
 (.0004"/10 micron TIR)
 (0.039"/1.0mm collapse range)



Premium / HP - High Precision Collet
 (.0002"/5 micron TIR)
 (.020/.5mm collapse range)



Steel-Sealed Coolant Collet
 1000 PSI - 0.0004"/10 micron TIR
 (no collapse range)

Operating Instructions

DIN 6499 – ISO 15488

Assembly Instructions

The ER Collet must first be inserted into the ER Nut before it can be put onto the Collet Chuck. Never insert the collet into the chuck and then attempt to tighten the nut over - this will damage the assembly. Make note of the high point of the eccentric ring (indicated by a "E" mark on the face of the Nut) and insert the collet such that the groove fits over the ring. Push the collet into position (you will hear a click) as per the illustration on the left. Now it is safe to thread the Nut and Collet assembly into the collet chuck.

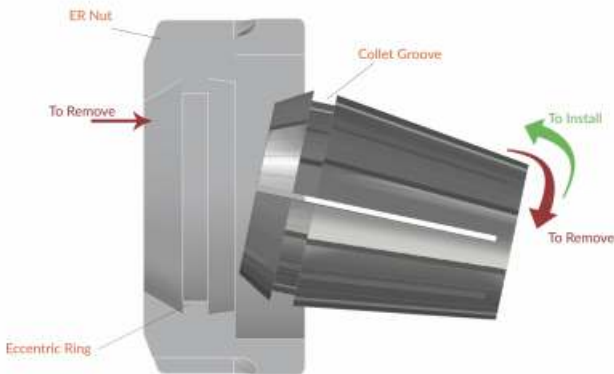

Disassembly Instructions

Remove the Nut and Collet assembly from the collet chuck and follow the instructions in reverse of the assembly steps. Press on the face of the collet (see red arrows) and push the collet down until the collet removes from the nut.

Please Note!

Correct assembly is critical for maintaining concentricity (TIR accuracy) of the collet - improper assembly may result in damage to the clamping nut.

All MC and HC Collets are supplied with Rubber and at seals that are removable not desired.

Never clamp oversized tool shanks!

Example: Never use a 11mm-10mm collet for a tool shank diameter of 11.2mm. Use the next size larger collet 11.5mm-11mm. All Accutek ER collets have .5mm collapse range.

For the best gripping strength and collet TIR accuracy, ensure that the full length of the cutting tool shank is inserted in the collet ID bore. If full insertion is not possible, make sure at least 2/3 of the shank is inserted into the ID bore. Improper tool shank insertion will permanently deform the collet and will result in poor collet TIR/runout.

Hardware and Accessories

ER Collets- Standard, High Precision, and Steel Sealed Collets - Inch and Metric ID Sizes

NOTE : Add HP to part number for High Precision, MP for Micron Precision or SS for Steel Sealed Collets.

ID Size	ER8	ER11	ER16	ER20	ER25	ER32	ER40
	Standard	Standard	Standard	Standard	Standard	Standard	Standard
1mm	95226010	95220010	95221010				
1.5mm	95226015	95220015	95221015				
1/16"	95226159	95220159	95221159	95222159			
5/64"	95226198	95220198	95221198	95222198			
2mm	95226020	95220020	95221020	95222020	95223020		
3/32"	95226238	95220238	95221238	95222238	95223238		
2.5mm	95226025	95220025	95221025	95222025	95223025		
7/64"	95226278	95220278	95221278	95222278	95223278		
3mm	95226030	95220030	95221030	95222030	95223030		
1/8"	95226318	95220318	95221318	95222318	95223318	95224318	95225318
3.5mm	95226035	95220035	95221035	95222035	95223035	95224035	95225035
9/64"	95226357	95220357	95221357	95222357	95223357	95224357	95225357
5/32"	95226397	95220397	95221397	95222397	95223397	95224397	95225397
4mm	95226040	95220040	95221040	95222040	95223040	95224040	95225040
11/64"	95226437	95220437	95221437	95222437	95223437	95224437	95225437
4.5mm	95226045	95220045	95221045	95222045	95223045	95224045	95225045
3/16"	95226476	95220476	95221476	95222476	95223476	95224476	95225476
5mm	95226050	95220050	95221050	95222050	95223050	95224050	95225050
13/64"		95220516	95221516	95222516	95223516	95224516	95225516
5.5mm		95220055	95221055	95222055	95223055	95224055	95225055
7/32"		95220556	95221556	95222556	95223556	95224556	95225556
15/64"		95220595	95221595	95222595	95223595	95224595	95225595
6mm		95220060	95221060	95222060	95223060	95224060	95225060
1/4"		95220635	95221635	95222635	95223635	95224635	95225635
6.5mm		95220065	95221065	95222065	95223065	95224065	95225065
17/64"		95220675	95221675	95222675	95223675	95224675	95225675
7mm		95220070	95221070	95222070	95223070	95224070	95225070
9/32"			95221714	95222714	95223714	95224714	95225714
7.5mm			95221075	95222075	95223075	95224075	95225075
19/64"			95221754	95222754	95223754	95224754	95225754
5/16"			95221794	95222794	95223794	95224794	95225794
8mm			95221080	95222080	95223080	95224080	95225080
21/64"			95221833	95222833	95223833	95224833	95225833
8.5mm			95221085	95222085	95223085	95224085	95225085
11/32"			95221873	95222873	95223873	95224873	95225873
9mm			95221090	95222090	95223090	95224090	95225090
23/64"			95221913	95222913	95223913	95224913	95225913
9.5mm			95221095	95222095	95223095	95224095	95225095
3/8"			95221953	95222953	95223953	95224953	95225953
25/64"			95221992	95222992	95223992	95224992	95225992
10mm			95221100	95222100	95223100	95224100	95225100
13/32"				95222102	95223102	95224102	95225102
10.5mm				95222105	95223105	95224105	95225105
27/64"				95222107	95223107	95224107	95225107
11mm				95222110	95223110	95224110	95225110
7/16"				95222111	95223111	95224111	95225111
11.5mm				95222115	95223115	95224115	95225115
29/64"				95222116	95223116	95224116	95225116
15/32"				95222119	95223119	95224119	95225119
12mm				95222120	95223120	95224120	95225120
31/64"				95222123	95223123	95224123	95225123
12.5mm				95222125	95223125	95224125	95225125
1/2"				95222127	95223127	95224127	95225127
13mm				95222130	95223130	95224130	95225130
33/64"					95223131	95224131	95225131
17/32"					95223134	95224134	95225134
13.5mm					95223135	95224135	95225135
35/64"					95223138	95224138	95225138
14mm					95223140	95224140	95225140
9/16"					95223142	95224142	95225142
14.5mm					95223145	95224145	95225145
37/64"					95223146	95224146	95225146
15mm					95223150	95224150	95225150
19/32"					95223151	95224151	95225151
39/64"					95223154	95224154	95225154
15.5mm					95223155	95224155	95225155
5/8"					95223158	95224158	95225158
16mm					95223160	95224160	95225160

Hardware and Accessories

ER Collets- Standard, High Precision, and Steel Sealed Collets - Inch and Metric ID Sizes

NOTE : Add HP to part number for High Precision, MP for Micron Precision or SS for Steel Sealed Collets.

ID Size	ER8	ER11	ER16	ER20	ER25	ER32	ER40
	Standard	Standard	Standard	Standard	Standard	Standard	Standard
41/64"						95224162	95225162
16.5mm						95224165	95225165
21/32"						95224166	95225166
17mm						95224170	95225170
43/64"						95224171	95225171
11/16"						95224174	95225174
17.5mm						95224175	95225175
45/64"						95224178	95225178
18mm						95224180	95225180
23/32"						95224182	95225182
18.5mm						95224185	95225185
47/64"						95224186	95225186
19mm						95224190	95225190
3/4"						95224191	95225191
49/64"						95224194	95225194
19.5mm						95224195	95225195
25/32"						95224198	95225198
20mm						95224200	95225200
51/64"							95225202
20.5mm							95225205
13/16"							95225206
21mm							95225210
53/64"							95225211
27/32"							95225214
21.5mm							95225215
55/64"							95225218
22mm							95225220
7/8"mm							95225222
22.5mm							95225225
57/64"							95225226
23mm							95225230
29/32"							95225231
59/64"							95225234
23.5mm							95225235
15/16"							95225238
24mm							95225240
61/64"							95225242
24.5mm							95225245
31/32"							95225246
25mm							95225250
63/64"							95225251
1.0"							95225254
25.5mm							95225255
26mm							95225260

ER Collet Nuts

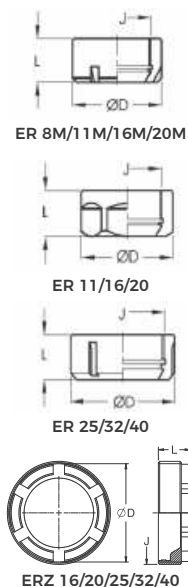

Catalog Number	Collet Size and Type	ØD (mm)	L (mm)	J (mm)
87921081	ER8M	12	11	M10x0.75
87921111	ER11M	16	10.8	M13x0.75
87921110	ER11	19	11.3	M14x0.75
87921161	ER16M	22	18	M19x1.0
87921160	ER16	28	17	M22x1.50
87921201	ER20M	28	19	M24x1.0
87921200	ER20	34	19	M25x1.5
87921251	ER25M	35	20	M30x1.0
87921250	ER25	42	20	M32x1.5
87921320	ER32	50	22	M40x1.5
87921400	ER40	63	25	M50x1.5
879Z21160	ER16Z	24	11.5	M24x1
879Z21200	ER20Z	28	12	M28x1.5
879Z21250	ER25Z	32	12.5	M32x1.5
879Z21320	ER32Z	40	12.4	M40x1.5
879Z21400	ER40Z	50	14.5	M50x1.5

Hardware and Accessories

ER Collet Sets



	Catalog Number	Collet Size	Number of Collets	Collets Included	Fits Shank Sizes
Inch ID Sets	95226000	ER08	9	.062-.187	.042-.187
	95220000	ER11	7	.062-.250	.062-.250
	95220001	ER11	13	.062-.250	.062-.250
	95221000	ER16	11	.093-.375	.062-.375
	95222000	ER20	15	.125-.500	.125-.500
	95223000	ER25	18	.125-.625	.125-.625
	95224000	ER32	21	.125-.750	.187-.750
	95225000	ER40	15	.125-1.00	.125-1.00
Metric ID Sets	95226009	ER08	9	1mm-5mm	.5mm-5mm
	95220009	ER11	13	1mm-7mm	.5mm-7mm
	95221009	ER16	10	1mm-10mm	.5mm-10mm
	95222009	ER20	12	2mm-13mm	1.0mm-13mm
	95223009	ER25	15	2mm-16mm	1.0mm-16mm
	95224009	ER32	18	3mm-20mm	2mm-20mm
	95225009	ER40	23	4mm-26mm	3mm-26mm

Note: High Precision (HP) and Steel Sealed (SS) Sets available

Effect of Tool Run-out (TIR) on Cutting Edge Tool Life

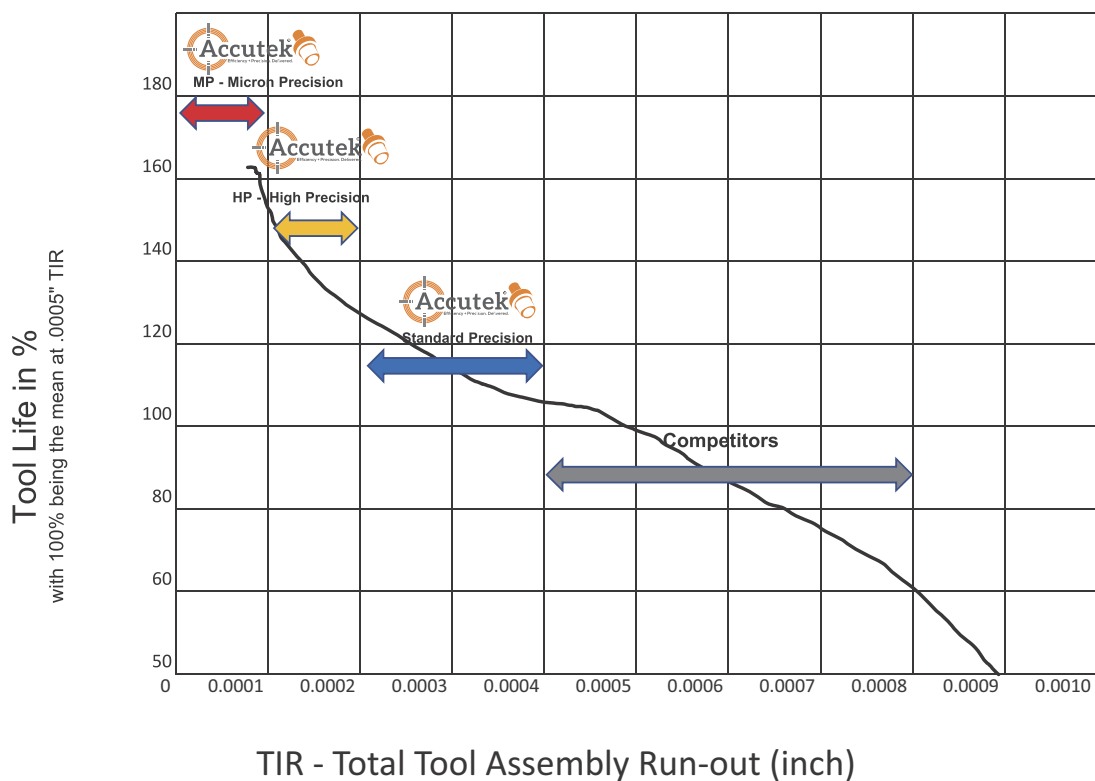

Hardware and Accessories

ER-T Collets - Inch Tap Collets for Rigid Tapping - DIN6499/ISO15488

Tap Collets are sized for tap shank diameter and tap shank square

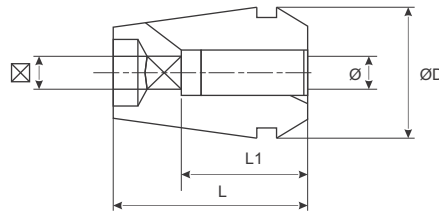

Collet Series	ØD	L
ER16	16mm	27.5mm
ER20	20mm	31.5mm
ER25	25mm	34.0mm
ER32	32mm	40.0mm
ER40	40mm	46.0mm

ANSI Standard Taps								
Tap Size	Shank Size	Square size	ER11	ER16	ER20	ER25	ER32	Er40
#0-#6	0.141	0.110		95531112	95532112		95534112	95535112
#8	0.168	0.131		95531147	95532147	95533147	95534147	95535147
#10	0.194	0.152		95531180	95532180	95533180	95534180	95535180
#12	0.220	0.165		95531218	95532218	95533218	95534218	95535218
1/4"	0.255	0.191		95531266	95532266	95533266	95534266	95535266
5/16"	0.318	0.238		95531324	95532324	95533324	95534324	95535324
3/8"	0.381	0.286			95532385	95533385	95534385	95535385
7/16"	0.323	0.242			95532330	95533330	95534330	95535330
1/2"	0.367	0.275			95532366	95533366	95534366	95535366
9/16"	0.429	0.322				95533402	95534402	95535402
5/8"	0.480	0.360				95533435	95534435	95535435
11/16"	0.542	0.406					95534460	95535460
3/4"	0.590	0.442					95534481	95535481
13/16"	0.652	0.489					95534652	95535652
7/8"	0.697	0.523						95535697
15/16"	0.760	0.570						95535760
1.0"	0.800	0.600						95535800
1/8"NPT	0.313	0.234			95532306	95533306	95534306	95535306
1/8" NPT	0.437	0.329				95533412	95534412	95535412
1/4" NPT	0.563	0.421					95534476	95535476
3/8" NPT	0.700	0.531						95535521

ER-T Collets - Metric Tap Collets for Rigid Tapping- DIN6499/ISO15488

Tap Collets are sized for tap shank diameter and tap shank square

ANSI Standard Taps								
Tap Size	Shank Size	Square Size	ER11	ER16	ER20	ER25	ER32	ER40
M3 (DIN371)	3.5	2.7	95530091	95531091	95532091	95533091	95534091	95535091
M3.5 (DIN371)	4.0	3.0	95530121	95531121	95532121	95533121	95534121	95535121
M6 (DIN376)	4.5	3.4	95530151	95531151	95532151	95533151	95534151	95535151
M6 (DIN371)	6.0	4.9	95530232	95531232	95532232	95533232	95534232	95535232
M8 (DIN376)	6.0	4.9	95530232	95531232	95532232	95533232	95534232	95535232
M10 (DIN376)	7.0	5.5	95530274	95531274	95532274	95533274	95534274	95535274
M8 (DIN371)	8.0	6.2		95531310	95532310	95533310	95534310	95535310
M12 (DIN376)	9.0	7.0		95531348	95532348	95533348	95534348	95535348
M10 (DIN371)	10.0	8.0		95531389	95532389	95533389	95534389	95535389
M14 (DIN376)	11.0	9.0			95532408	95533408	95534408	95535408
M16 (DIN376)	12.0	9.0			95532430	95533430	95534430	95535430
M18 (DIN376)	14.0	11.0				95533465	95534465	95535465
M20 (DIN376)	16.0	12.0				95533491	95534491	95535491
M22/M24 (DIN376)	18.0	14.5					95534531	95535531
M27 (DIN376)	20.0	16.0					95534556	95535556
M30 (DIN376)	22.0	18.0					95534578	95535578
M33 (DIN376)	25.0	20.0					95534615	95535615

Hardware and Accessories

Straight Shank

ER Collet Holder

Accutek Style SSH-CHE Cylindrical straight shank with no flats on shank. Can be used in Swiss style machines as well as ER collets for extended reach when required. All SSH Style holders will have ER Hex nut for ER11 - ER20 and Y-Spanner nut for ER25, ER32, and ER40.

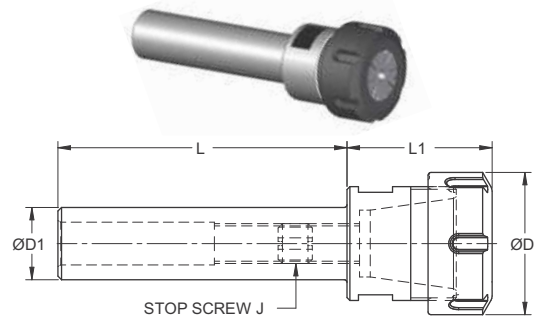

Accutek Style SSH-CHE-M Cylindrical straight shank with no flats on shank. Can be used in Swiss style machines as well as ER collets for extended reach when required. All SSH-CHE-M Style holders will have ER Mini- nut for ER11 - ER25.

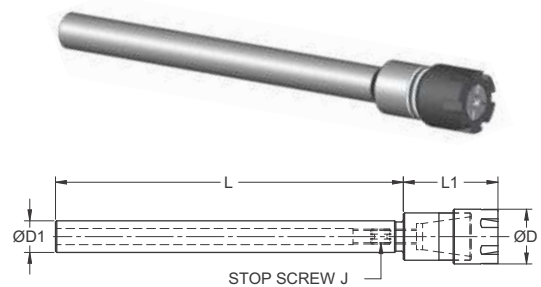

Accutek Style SSHF-CHE-M Cylindrical straight shank with flats on shank. Can be used in Swiss style machines as well as ER collets for extended reach when required. All SSH-CHE-M Style holders will have ER Mini- nut for ER11 - ER25.

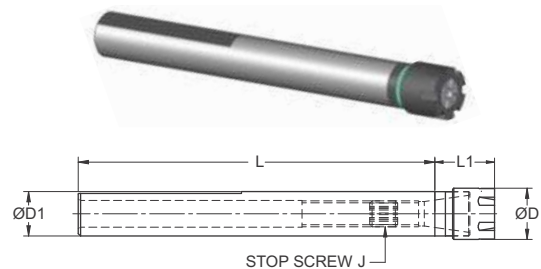

Accutek Style SSH-NC-CHE Cylindrical straight shank with flats on shank. Can be used in conventional CNC lathe machines. All SSH-NC-M Style holders will have ER Y Spanner nuts ER25-ER40.

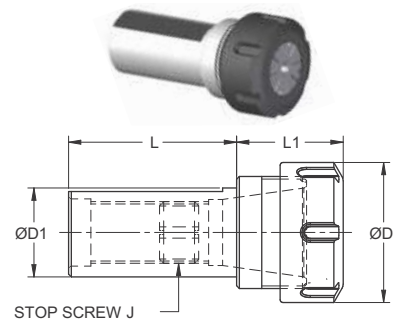

Accutek Style SSH-DEF-CHE-M Cylindrical straight shank with flats on shank and dual ER collet ends. Can be used in Swiss style machines as well as ER collets for extended reach when required. All SSH-DE-CHE-M Style holders will have ER Mini- nut for ER8 - ER20.

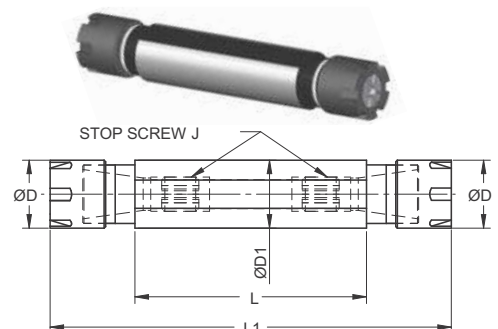

Hardware and Accessories

Straight Shank

ER Collet Holder - SSH-CHE - NO FLAT ON SHANK

Catalog Number	Description	Machine Brand	ER Collet	Stop Screw J	ØD1	Shank L	Proj LI	ØD	Flat on Shank
87241014	SSH-.500-CHE 11-2.75	Various	ER11	M6x1	0.500	2.75	1.12	0.748	N
87241028	SSH-.500-CHE 11-5.50	Various	ER11	M6X1	0.500	5.50	1.12	0.748	N
87241120	SSH-.500-CHE 16-4.00	Various	ER16	M6X1	0.500	4.00	1.50	1.102	N
87241220	SSH-.500-CHE 20-4.00	Various	ER20	M6X1	0.500	4.00	1.75	1.338	N
87242112	SSH-.625-CHE 16-2.36	Various	ER16	5/16-24LH	0.625	2.36	1.44	1.102	N
87242220	SSH-.625-CHE 20-4.00	Tornos	ER16	5/16-24LH	0.625	4.00	1.75	1.338	N
87245110	SSH-.750-CHE 16-2.00	Citizen	ER16	7/16-16LH	0.750	2.00	1.25	1.102	N
87245120	SSH-.750-CHE 16-4.00	Citizen	ER16	7/16-16LH	0.750	4.00	1.25	1.102	N
87245125	SSH-.750-CHE 16-5.00	-	ER16	7/16-16LH	0.750	5.00	1.25	1.102	N
87245212	SSH-.750-CHE 20-2.36	Citizen	ER20	7/16-16LH	0.750	2.36	1.50	1.338	N
87245228	SSH-.750-CHE 20-5.50	Various	ER20	7/16-16LH	0.750	5.50	1.50	1.338	N
87245310	SSH-.750-CHE 25-2.00	Citizen	ER25	7/16-16LH	0.750	2.00	1.88	1.653	N
87246110	SSH-20-CHE 16-50	Tsugami	ER16	M10x1.5	20mm	50mm	32mm	28mm	N
87246120	SSH-20-CHE 16-100	Tsugami	ER16	M10x1.5	20mm	100mm	32mm	28mm	N
87246206	SSH-20-CHE 20-30	Tsugami	ER20	M10x1.5	20mm	30mm	38mm	34mm	N
87246212	SSH-20-CHE 20-60	Tsugami	ER20	M10x1.5	20mm	60mm	38mm	34mm	N
87246310	SSH-20-CHE 25-50	Tsugami	ER25	M10x1.5	20mm	50mm	47mm	42mm	N
87246320	SSH-20-CHE 25-100	Tsugami	ER25	M10x1.5	20mm	100mm	47mm	42mm	N
87246410	SSH-20-CHE 32-50	Tsugami	ER32	M10x1.5	20mm	50mm	55mm	50mm	N
87246420	SSH-20-CHE 32-100	Tsugami	ER32	M10x1.5	20mm	100mm	55mm	50mm	N
87251220	SSH-1.00-CHE 20-4.00	Various	ER20	9/16-16LH	1.000	4.00	1.57	1.338	N
87251230	SSH-1.00-CHE 20-6.00	Various	ER20	9/16-16LH	1.000	6.00	1.57	1.338	N
87251310	SSH-1.00-CHE 25-2.00	Citizen/Miyano	ER25	11/16-16LH	1.000	2.00	1.88	1.653	N
87251320	SSH-1.00-CHE 25-4.00	Citizen/Miyano	ER25	11/16-16LH	1.000	4.00	1.88	1.653	N
87251410	SSH-1.00-CHE 32-2.00	Citizen/Miyano	ER32	M14x2	1.000	2.00	2.00	1.968	N
87251420	SSH-1.00-CHE 32-4.00	Citizen/Miyano	ER32	M14x2	1.000	4.00	2.00	1.968	N
87251425	SSH-1.00-CHE 32-5.00	Citizen/Miyano	ER32	M14x2	1.000	5.00	2.00	1.968	N
87251510	SSH-1.00-CHE 40-2.00	Citizen/Miyano	ER40	M14x2	1.000	2.00	2.36	2.48	N
87250310	SSH-25-CHE 25-50	Tornos	ER25	M16x2	25mm	50mm	50mm	42mm	N
87250320	SSH-25-CHE 25-100	Tornos	ER25	M16x2	25mm	100mm	50mm	42mm	N
87250410	SSH-25-CHE 32-50	Tornos	ER32	M16x2	25mm	50mm	55mm	50mm	N
87250510	SSH-25-CHE 40-50	Tornos	ER40	M16x2	25mm	50mm	60mm	63mm	N
87254412	SSH-1.250-CHE 32-2.50	Various	ER32	7/8-16LH	1.25	2.50	2.10	1.968	N
87254428	SSH-1.250-CHE 32-5.50	Various	ER32	7/8-16LH	1.25	5.50	2.10	1.968	N

Hardware and Accessories

Straight Shank

ER Collet Holder - SSH-CHE (M) - NO FLAT ON SHANK

Catalog Number	Description	Machine Brand	ER Collet	Stop Screw J	ØD1	Shank L	Proj L1	ØD	Flat on Shank
872410M14	SSH-500-CHE 11M-2.75	-	ER11	M6x1	0.500	2.75	1.18	0.63	N
872410M28	SSH-500-CHE 11M-5.50	Various	ER11	M6x1	0.500	5.50	1.18	0.63	N
872411M14	SSH-500-CHE 16M-2.75	-	ER16	M6x1	0.500	2.75	1.50	0.866	N
872411M28	SSH-500-CHE 16M-5.50	Various	ER16	M6x1	0.500	5.50	1.50	0.866	N
872412M28	SSH-500-CHE 20M-5.50	Various	ER20	M6x1	0.500	5.50	1.75	1.10	N
872420M28	SSH-625-CHE 11M-5.50	-	ER11	5/16-24LH	0.500	5.50	0.88	0.63	N
872420M30	SSH-625-CHE 11M-6.00	Tornos	ER11	5/16-24LH	0.625	6.00	0.88	0.63	N
872451M30	SSH-750-CHE 16M-6.00	Citizen	ER16	7/16-16LH	0.750	6.00	1.10	0.866	N
872452M28	SSH-750-CHE 20M-5.50	Various	ER20	7/16-16LH	0.750	5.50	1.60	1.10	N
872453M20	SSH-750-CHE 25M-4.00	Citizen	ER25	7/16-16LH	0.750	4.00	1.88	1.38	N
8772453M25	SSH-750-CHE 25M-5.00	-	ER25	7/16-16LH	0.750	5.00	1.88	1.378	N
872461M22	SSH-20-CHE 16M-110	-	ER16	M10x1.5	20mm	110mm	25.5mm	22mm	N
872461M31	SSH-20-CHE 16M-155	Tsugami	ER16	M10x1.5	20mm	155mm	25.5mm	22mm	N
872462M24	SSH-20-CHE 20M-120	-	ER20	M12x1.75	20mm	120mm	40mm	28mm	N
872462M36	SSH-20-CHE 20M-180	Various	ER20	M12x1.75	20	140	40	28	N
872462M42	SSH-20-CHE 20M-8.20	-	ER20	M12x1.75	20mm	8.20	1.57	1.102	N
872501M19	SSH-25-CHE 16M-95	-	ER16	M10x1.5	25mm	95mm	25.5mm	22mm	N
872502M31	SSH-25-CHE 20M-155	Tornos	ER20	M12x1.75	25	155	27	28	N
872503M24	SSH-25-CHE 25M-120	-	ER25	M16x2	25mm	120mm	36mm	35mm	N
872512M30	SSH-1.00-CHE 20M-6.00	Citizen/Miyano	ER20	9/16-16LH	1.000	6.00	1.10	1.10	N
872513M28	SSH-1.00-CHE 25M-5.50	-	ER25	11/16-16LH	1.000	5.50	2.00	1.378	N
872513M34	SSH-1.00-CHE 25M-6.70	-	ER25	11/16-16LH	1.000	6.70	2.00	1.378	N

Straight Shank - ER Collet Holder - MODEL SSH-NC-CHE - FLAT ON SHANK

Catalog Number	Description	Machine Brand	ER Collet	Stop Screw J	ØD1	Shank L	Proj L1	ØD	Flat on Shank
87254F312	SSHF-NC-1.250-CHE 25-2.36	Various	ER25	11/16-16LH	1.250	2.36	1.25	1.653	Y
87254F318	SSHF-NC-1.250-CHE 25-3.62	-	ER25	11/16-16LH	1.250	3.62	1.25	1.653	Y
87254F412	SSHF-NC-1.250-CHE 32-2.36	Various	ER32	M22x1.5	1.250	2.36	1.50	1.968	Y
87254F425	SSHF-NC-1.250-CHE 32-4.86	-	ER32	M22x1.5	1.250	4.86	1.50	1.968	Y
87254F420	SSHF-NC-1.250-CHE 32-3.86	Various	ER32	M22x1.5	1.250	3.86	1.50	1.968	Y
87254F512	SSHF-NC-1.250-CHE 40-2.36	Various	ER32	M22x1.5	1.250	2.36	2.20	2.480	Y
87259F416	SSHF-NC-1.500-CHE 32-3.15	Various	ER32	M22x1.5	1.500	3.15	1.50	1.968	Y
87259F423	SSHF-NC-1.500-CHE 32-4.50	-	ER32	M22x1.5	1.500	4.50	1.50	1.968	Y
87259F425	SSHF-NC-1.500-CHE 32-5.00	-	ER32	M22x1.5	1.500	5.00	1.50	1.968	Y
87259F515	SSHF-NC-1.500-CHE 40-3.00	Various	ER40	M22x1.5	1.500	3.00	2.20	2.480	Y
87259F528	SSHF-NC-1.500-CHE 40-5.50	Various	ER40	M22x1.5	1.500	5.50	2.20	2.480	Y

Straight Shank - ER Collet Holder - MODEL SSH-DEF-CHE (M) - FLAT ON SHANK

Catalog Number	Description	Machine Brand	ER Collet	Stop Screw J	ØD1	Shank L	Proj L1	ØD	Flat on Shank
872430M0M18	SSH-DEF-16-CHE 11M-50	Star	ER11	M6x1	16	50	89	16	Y
872450M M16	SSH-DEF-.750-CHE 11M-40	Citizen	ER11	5/16-24LH	19.05	40	79	16	Y
872450M0M22	SSH-DEF-.750-CHE 11M-70	Citizen	ER11	5/16-24LH	19.05	70	109	16	Y
872450M0M26	SSH-DEF-.750-CHE 11M-90	Citizen	ER11	5/16-24LH	19.05	90	129	16	Y
872451M1M21	SSH-DEF-.750-CHE 16M-55	Citizen	ER16	7/16-16LH	19.05	55	107	22	Y
872460M0M14	SSH-DEF-20-CHE 11M-30	Tsugami	ER11	5/16-24LH	20	30	69	16	Y
872460M0M28	SSH-DEF-20-CHE 11M-50	Tsugami	ER11	5/16-24LH	20	50	89	16	Y
872461M1M21	SSH-DEF-20-CHE 16M-55	Tsugami	ER16	7/16-16LH	20	55	107	22	Y
872471M1M22	SSH-DEF-22-CHE 16M-55	Star/Tsugami	ER16	7/16-16LH	22	55	110	22	Y
872471M1M26	SSH-DEF-22-CHE 16M-75	Star/Tsugami	ER16	7/16-16LH	22	75	130	22	Y
872501M1M24	SSH-DEF-25-CHE 16M-62	Tornos	ER16	7/16-16LH	25	62	117	22	Y
872511M1M24	SSH-DEF-1.00-CHE 16M-62	Miyano	ER16	7/16-16LH	25.4	62	117	22	Y
872552M2M22	SSH-DEF-32-CHE 20M-55	Various	ER20	9/16-16LH	32	55	110	28	Y
872552M2M26	SSH-DEF-32-CHE 20M-75	Various	ER20	9/16-16LH	32	75	130	28	Y

Hardware and Accessories

Straight Shank - ER Collet Holder - MODEL SSHF-CHE (M) - FLAT ON SHANK

Catalog Number	Description	Machine Brand	ER Collet	Stop Screw J	ØD1	Shank L	Proj L1	ØD	Flat on Shank
87242F0M08	SSHF-.625-CHE 11M-1.50	Various	ER11	5/16-24LH	0.625	1.50	0.75	0.63	Y
87242F0M28	SSHF-.625-CHE 11M-5.50	Various	ER11	5/16-24LH	0.625	5.50	0.75	0.63	Y
87243F0M08	SSHF-16-CHE 11M-38	Star	ER11	M8x1	16mm	38mm	19mm	16mm	Y
87243F0M28	SSHF-16-CHE 11M-140	Star	ER11	M8x1	16mm	140mm	19mm	16mm	Y
87245F0M23	SSHF-.750-CHE 11M-4.50	Citizen	ER11	7/16-16LH	0.750	4.50	0.75	0.63	Y
87245F1M08	SSHF-.750-CHE 16M-1.50	Citizen	ER16	7/16-16LH	0.750	1.50	1.10	0.866	Y
87245F1M14	SSHF-.750-CHE 16M-2.75	Citizen	ER16	7/16-16LH	0.750	2.75	1.10	0.866	Y
87245F1M24	SSHF-.750-CHE 16M-4.75	Citizen	ER16	7/16-16LH	0.750	4.75	1.10	0.866	Y
87245F1M28	SSHF-.750-CHE 16M-5.50	Citizen	ER16	7/16-16LH	0.750	5.50	1.10	0.866	Y
87245F1M30	SSHF-.750-CHE 16M-6.00	-	ER16	7/16-16LH	0.750	6.00	1.10	0.866	Y
87246F0M12	SSHF-20-CHE 11M-60	Various	ER11	M8x1	20mm	60mm	19mm	16mm	Y
87246F1M08	SSHF-20-CHE 16M-38	Various	ER16	M10x1.5	20mm	38mm	27mm	22mm	Y
87246F1M14	SSHF-20CHE 16M-70	Tsugami	ER16	M10x1.5	20mm	70mm	27mm	22mm	Y
87246F1M24	SSHF-20-CHE 16M-120	Tsugami	ER16	M10x1.5	20mm	120mm	27mm	22mm	Y
87246F1M28	SSHF-20-CHE 16M-140	Tsugami	ER16	M10x1.5	20mm	140mm	27mm	22mm	Y
87251F1M07	SSHF-1.00-CHE 16M-1.30	Various	ER16	7/16-16LH	1.000	1.30	1.10	0.866	Y
87251F1M13	SSHF-1.00-CHE 16M-2.55	Citizen/Miyano	ER16	7/16-16LH	1.000	2.55	1.10	0.866	Y
87251F1M15	SSHF-1.00-CHE 16M-3.00	Citizen/Miyano	ER16	7/16-16LH	1.000	3.00	1.10	0.866	Y
87251F1M20	SSHF-1.00-CHE 16M-4.00	Citizen/Miyano	ER16	7/16-16LH	1.000	4.00	1.10	0.866	Y
87251F1M26	SSHF-1.00-CHE 16M-130	-	ER16	7/16-16LH	1.000	130mm	1.10	0.866	Y
87251F2M20	SSHF-1.00-CHE 20M-4.00	Citizen/Miyano	ER20	9/16-16LH	1.000	4.00	1.10	1.10	Y
87251F2M28	SSHF-1.00-CHE 20M-5.50	Citizen/Miyano	ER20	9/16-16LH	1.000	5.50	1.10	1.10	Y
87251F2M34	SSHF-1.00-CHE 20M-6.64	-	ER20	9/16-16LH	1.000	6.64	1.10	1.102	Y
87250F1M13	SSHF-25-CHE 16M-65	Tornos	ER16	M10x1.5	25mm	65mm	28mm	22mm	Y
87250F1M19	SSHF-25-CHE 16M-95	-	ER16	M10x1.5	25mm	95mm	28mm	22mm	Y
87250F2M20	SSHF-25-CHE 20M-100	Tornos	ER20	M12x1.75	25mm	100mm	28mm	28mm	Y
87250F2M30	SSHF-25-CHE 20M-150	Tornos	ER20	M12x1.75	25mm	150mm	28mm	28mm	Y
872503M15	SSHF-25-CHE 25M-75	Tornos	ER25	M16x2	25mm	75mm	50mm	35mm	Y
872503M29	SSHF-25-CHE 25M-145	Tornos	ER25	M16x2	25mm	145mm	36mm	35mm	Y

Hardware and Accessories

Reduction Collets for AccuMill™ Multi Milling Chucks and AccuClamp™ Hydraulic Chucks

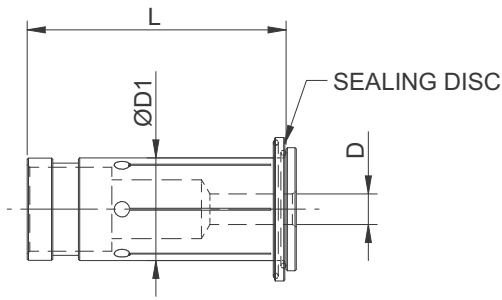

COLLET FOR ACCUMILL MULTI MILLING CHUCKS
MODEL - MC

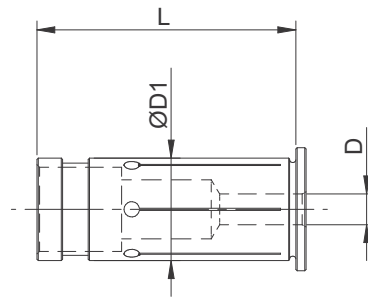

COLLET FOR ACCUCLAMP HYDRAULIC CHUCKS
MODEL - HC

Series	ØD1	L
MC20	0.787	2.00
MC32	1.260	2.38
MC75	0.750	2.00
MC125	1.250	2.38

20mm MMC		20mm HCS		0.75" MMC		0.75" HCS	
Catalog Number	Description	Catalog Number	Description	Catalog Number	Description	Catalog Number	Description
954MC020003	MC20-3mm	954HC020003	HC20-3mm	954MC075003	MC75-3mm	954HC075003	HC75-3mm
954MC020004	MC20-4mm	954HC020004	HC20-4mm	954MC075004	MC75-4mm	954HC075004	HC75-4mm
954MC020005	MC20-5mm	954HC020005	HC20-5mm	954MC075005	MC75-5mm	954HC075005	HC75-5mm
954MC020006	MC20-6mm	954HC020006	HC20-6mm	954MC075006	MC75-6mm	954HC075006	HC75-6mm
954MC020007	MC20-7mm	954HC020007	HC20-7mm	954MC075007	MC75-7mm	954HC075007	HC75-7mm
954MC020008	MC20-8mm	954HC020008	HC20-8mm	954MC075008	MC75-8mm	954HC075008	HC75-8mm
954MC020009	MC20-9mm	954HC020009	HC20-9mm	954MC075009	MC75-9mm	954HC075009	HC75-9mm
954MC020010	MC20-10mm	954HC020010	HC20-10mm	954MC075010	MC75-10mm	954HC075010	HC75-10mm
954MC020011	MC20-11mm	954HC020011	HC20-11mm	954MC075011	MC75-11mm	954HC075011	HC75-11mm
954MC020012	MC20-12mm	954HC020012	HC20-12mm	954MC075012	MC75-12mm	954HC075012	HC75-12mm
954MC020013	MC20-13mm	954HC020013	HC20-13mm	954MC075013	MC75-13mm	954HC075013	HC75-13mm
954MC020014	MC20-14mm	954HC020014	HC20-14mm	954MC075014	MC75-14mm	954HC075014	HC75-14mm
954MC020015	MC20-15mm	954HC020015	HC20-15mm	954MC075015	MC75-15mm	954HC075015	HC75-15mm
954MC020016	MC20-16mm	954HC020016	HC20-16mm	954MC075016	MC75-16mm	954HC075016	HC75-16mm
954MC020125	MC20- 1/8"	954HC020125	HC20- 1/8"	954MC075125	MC75-1/8"	954HC075125	HC75-1/8"
954MC020187	MC20- 3/16"	954HC020187	HC20- 3/16"	954MC075187	MC75-3/16"	954HC075187	HC75-3/16"
954MC020250	MC20-1/4"	954HC020250	HC20-1/4"	954MC075250	MC75-1/4"	954HC075250	HC75-1/4"
954MC020312	MC20-5/16"	954HC020312	HC20-5/16"	954MC075312	MC75-5/16"	954HC075312	HC75-5/16"
954MC020375	MC20-3/8"	954HC020375	HC20-3/8"	954MC075375	MC75-3/8"	954HC075375	HC75-3/8"
954MC020437	MC20-7/16"	954HC020437	HC20-7/16"	954MC075437	MC75-7/16"	954HC075437	HC75-7/16"
954MC020500	MC20-1/2"	954HC020500	HC20-1/2"	954MC075500	MC75-1/2"	954HC075500	HC75-1/2"
954MC020562	MC20-9/16"	954HC020562	HC20-9/16"	954MC075562	MC75-9/16"	954HC075562	HC75-9/16"
954MC020625	MC20-5/8"	954HC020625	HC20-5/8"	954MC075625	MC75-5/8"	954HC075625	HC75-5/8"

All MC and HC Collets are supplied with Rubber and Aluminum Coolant seals that are removable but not desired.

Hardware and Accessories

Reduction Collets for AccuMill™ Multi Milling Chucks and AccuClamp™ Hydraulic Chucks

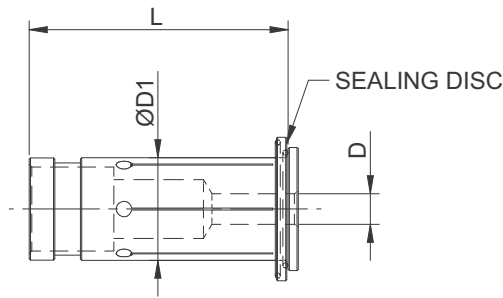

COLLET FOR ACCUMILL MULTI MILLING CHUCKS
MODEL - MC

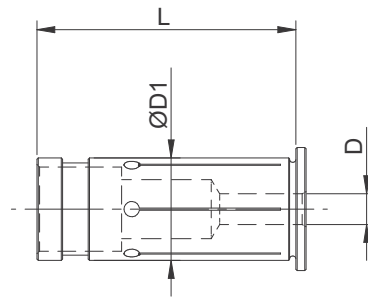

COLLET FOR ACCUCLAMP HYDRAULIC CHUCKS
MODEL - HC

Series	ØD1	L
MC20	0.787	2.00
MC32	1.260	2.38
MC75	0.750	2.00
MC125	1.250	2.38

32mm MMC		32mm HCS		1.25" MMC		1.25" HCS	
Catalog Number	Description	Catalog Number	Description	Catalog Number	Description	Catalog Number	Description
954MC032003	MC32-3mm	954HC032003	HC32-3mm	954MC125003	MC125-3mm	954HC125003	HC125-3mm
954MC032004	MC32-4mm	954HC032004	HC32-4mm	954MC125004	MC125-4mm	954HC125004	HC125-4mm
954MC032005	MC32-5mm	954HC032005	HC32-5mm	954MC125005	MC125-5mm	954HC125005	HC125-5mm
954MC032006	MC32-6mm	954HC032006	HC32-6mm	954MC125006	MC125-6mm	954HC125006	HC125-6mm
954MC032007	MC32-7mm	954HC032007	HC32-7mm	954MC125007	MC125-7mm	954HC125007	HC125-7mm
954MC032008	MC32-8mm	954HC032008	HC32-8mm	954MC125008	MC125-8mm	954HC125008	HC125-8mm
954MC032009	MC32-9mm	954HC032009	HC32-9mm	954MC125009	MC125-9mm	954HC125009	HC125-9mm
954MC032010	MC32-10mm	954HC032010	HC32-10mm	954MC125010	MC125-10mm	954HC125010	HC125-10mm
954MC032011	MC32-11mm	954HC032011	HC32-11mm	954MC125011	MC125-11mm	954HC125011	HC125-11mm
954MC032012	MC32-12mm	954HC032012	HC32-12mm	954MC125012	MC125-12mm	954HC125012	HC125-12mm
954MC032013	MC32-13mm	954HC032013	HC32-13mm	954MC125013	MC125-13mm	954HC125013	HC125-13mm
954MC032014	MC32-14mm	954HC032014	HC32-14mm	954MC125014	MC125-14mm	954HC125014	HC125-14mm
954MC032015	MC32-15mm	954HC032015	HC32-15mm	954MC125015	MC125-15mm	954HC125015	HC125-15mm
954MC032016	MC32-16mm	954HC032016	HC32-16mm	954MC125016	MC125-16mm	954HC125016	HC125-16mm
954MC032017	MC32-17mm	954HC032017	HC32-17mm	954MC125017	MC125-17mm	954HC125017	HC125-17mm
954MC032018	MC32-18mm	954HC032018	HC32-18mm	954MC125018	MC125-18mm	954HC125018	HC125-18mm
954MC032019	MC32-19mm	954HC032019	HC32-19mm	954MC125019	MC125-19mm	954HC125019	HC125-19mm
954MC032020	MC32-20mm	954HC032020	HC32-20mm	954MC125020	MC125-20mm	954HC125020	HC125-20mm
954MC032021	MC32-21mm	954HC032021	HC32-21mm	954MC125021	MC125-21mm	954HC125021	HC125-21mm
954MC032022	MC32-22mm	954HC032022	HC32-22mm	954MC125022	MC125-22mm	954HC125022	HC125-22mm
954MC032023	MC32-23mm	954HC032023	HC32-23mm	954MC125023	MC125-23mm	954HC125023	HC125-23mm
954MC032024	MC32-24mm	954HC032024	HC32-24mm	954MC125024	MC125-24mm	954HC125024	HC125-24mm
954MC032025	MC32-25mm	954HC032025	HC32-25mm	954MC125025	MC125-25mm	954HC125025	HC125-25mm
954MC032125	MC32-1/8"	954HC032125	HC32-1/8"	954MC125125	MC125-1/8"	954HC125125	HC125-1/8"
954MC032187	MC32-3/16"	954HC032187	HC32-3/16"	954MC125187	MC125-3/16"	954HC125187	HC125-3/16"
954MC032250	MC32-1/4"	954HC032250	HC32-1/4"	954MC125250	MC125-1/4"	954HC125250	HC125-1/4"
954MC032312	MC32-5/16"	954HC032312	HC32-5/16"	954MC125312	MC125-5/16"	954HC125312	HC125-5/16"
954MC032375	MC32-3/8"	954HC032375	HC32-3/8"	954MC125375	MC125-3/8"	954HC125375	HC125-3/8"
954MC032437	MC32-7/16"	954HC032437	HC32-7/16"	954MC125437	MC125-7/16"	954HC125437	HC125-7/16"
954MC032500	MC32-1/2"	954HC032500	HC32-1/2"	954MC125500	MC125-1/2"	954HC125500	HC125-1/2"
954MC032562	MC32-9/16"	954HC032562	HC32-9/16"	954MC125562	MC125-9/16"	954HC125562	HC125-9/16"
954MC032625	MC32-5/8"	954HC032625	HC32-5/8"	954MC125625	MC125-5/8"	954HC125625	HC125-5/8"
954MC032750	MC32-3/4"	954HC032750	HC32-3/4"	954MC125750	MC125-3/4"	954HC125750	HC125-3/4"
954MC032875	MC32-7/8"	954HC032875	HC32-7/8"	954MC125875	MC125-7/8"	954HC125875	HC125-7/8"
954MC032100	MC32-1"	954HC032100	HC32-1"	954MC125100	MC125-1"	954HC125100	HC125-1"

All MC and HC Collets are supplied with Rubber and Aluminum Coolant seals that are removable but not desired.

Hardware and Accessories

Tool Holder Bushing Type-C

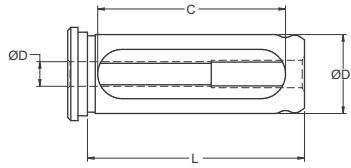

Catalog Number	Description	ØD (inch)	ØD1 (inch)	C (inch)	L (inch)	No. Slots
C750250	Type C Bushing 0.750OD x 0.250ID	0.250	0.750	1.88	2.25	1
C750312	Type C Bushing 0.750OD x 0.312ID	0.312	0.750	1.88	2.25	1
C750375	Type C Bushing 0.750OD x 0.375ID	0.375	0.750	1.88	2.25	1
C750500	Type C Bushing 0.750OD x 0.500ID	0.500	0.750	1.88	2.25	1
C100250	Type C Bushing 1.000OD x 0.250ID	0.250	1.000	2.38	2.75	1
C100312	Type C Bushing 1.000OD x 0.312ID	0.312	1.000	2.38	2.75	1
C100375	Type C Bushing 1.000OD x 0.375ID	0.375	1.000	2.38	2.75	1
C100500	Type C Bushing 1.000OD x 0.500ID	0.500	1.000	2.38	2.75	1
C100625	Type C Bushing 1.000OD x 0.625ID	0.625	1.000	2.38	2.75	1
C100750	Type C Bushing 1.000OD x 0.750ID	0.750	1.000	2.38	2.75	1
C125375	Type C Bushing 1.250OD x 0.375ID	0.375	1.250	2.85	3.25	1
C125500	Type C Bushing 1.250OD x 0.500ID	0.500	1.250	2.85	3.25	1
C125625	Type C Bushing 1.250OD x 0.625ID	0.625	1.250	2.85	3.25	1
C125750	Type C Bushing 1.250OD x 0.750ID	0.750	1.250	2.85	3.25	1
C125875	Type C Bushing 1.250OD x 0.875ID	0.875	1.250	2.85	3.25	1
C125100	Type C Bushing 1.250OD x 1.000ID	1.000	1.250	2.85	3.25	1
C150375	Type C Bushing 1.500OD x 0.375ID	0.375	1.500	3.00	3.38	1
C150500	Type C Bushing 1.500OD x 0.500ID	0.500	1.500	3.00	3.38	1
C150625	Type C Bushing 1.500OD x 0.625ID	0.625	1.500	3.00	3.38	1
C150750	Type C Bushing 1.500OD x 0.750ID	0.750	1.500	3.00	3.38	1
C150875	Type C Bushing 1.500OD x 0.875ID	0.875	1.500	3.00	3.38	1
C150100	Type C Bushing 1.500OD x 1.000ID	1.000	1.500	3.00	3.38	1
C150125	Type C Bushing 1.500OD x 1.250ID	1.250	1.500	3.00	3.38	1
C175500	Type C Bushing 1.750OD x 0.500ID	0.500	1.750	3.13	3.50	1
C175625	Type C Bushing 1.750OD x 0.625ID	0.625	1.750	3.13	3.50	1
C175750	Type C Bushing 1.750OD x 0.750ID	0.750	1.750	3.13	3.50	1
C175875	Type C Bushing 1.750OD x 0.875ID	0.875	1.750	3.13	3.50	1
C175100	Type C Bushing 1.750OD x 1.000ID	1.000	1.750	3.13	3.50	1
C175125	Type C Bushing 1.750OD x 1.250ID	1.250	1.750	3.13	3.50	1
C175150	Type C Bushing 1.750OD x 1.500ID	1.500	1.750	3.13	3.50	1
C200500	Type C Bushing 2.000OD x 0.500ID	0.500	2.000	3.63	4.00	1
C200625	Type C Bushing 2.000OD x 0.625ID	0.625	2.000	3.63	4.00	1
C200750	Type C Bushing 2.000OD x 0.750ID	0.750	2.000	3.63	4.00	1
C200875	Type C Bushing 2.000OD x 0.875ID	0.875	2.000	3.63	4.00	1
C200100	Type C Bushing 2.000OD x 1.000ID	1.000	2.000	3.63	4.00	1
C200125	Type C Bushing 2.000OD x 1.250ID	1.250	2.000	3.63	4.00	1
C200150	Type C Bushing 2.000OD x 1.500ID	1.500	2.000	3.63	4.00	1
C200175	Type C Bushing 2.000OD x 1.750ID	1.750	2.000	3.63	4.00	1
C250750	Type 'C' Bushing 2.500 O.D. & ID 0.750	0.750	2.500	4.13	4.50	1
C250100	Type 'C' Bushing 2.500 O.D. & ID 1.000	1.000	2.500	4.13	4.50	1
C250125	Type 'C' Bushing 2.500 O.D. & ID 1.250	1.250	2.500	4.13	4.50	1
C250150	Type 'C' Bushing 2.500 O.D. & ID 1.500	1.500	2.500	4.13	4.50	1
C250175	Type 'C' Bushing 2.500 O.D. & ID 1.750	1.750	2.500	4.13	4.50	1
C250200	Type 'C' Bushing 2.500 O.D. & ID 2.000	2.000	2.500	4.13	4.50	1
C250225	Type 'C' Bushing 2.500 O.D. & ID 2.250	2.250	2.500	4.13	4.50	1

Hardware and Accessories

Tool Holder Bushing Type-B

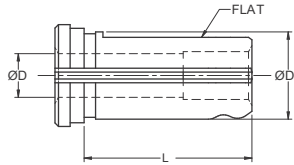

Catalog Number	Description	ØD (inch)	ØD1 (inch)	L (inch)
B750250	Type B Bushing 0.750OD x 0.250ID	0.250	0.750	1.44
B750312	Type B Bushing 0.750OD x 0.312ID	0.312	0.750	1.44
B750375	Type B Bushing 0.750OD x 0.375ID	0.375	0.750	1.44
B750500	Type B Bushing 0.750OD x 0.500ID	0.500	0.750	1.44
B100250	Type B Bushing 1.000OD x .250ID	0.250	1.000	1.72
B100312	Type B Bushing 1.000OD x .312ID	0.312	1.000	1.72
B100375	Type B Bushing 1.000OD x .375ID	0.375	1.000	1.72
B100500	Type B Bushing 1.000OD x .500ID	0.500	1.000	1.72
B100625	Type B Bushing 1.000OD x .625ID	0.625	1.000	1.72
B100750	Type B Bushing 1.000OD x .750ID	0.750	1.000	1.72
B125375	Type 'B' Bushing 1.250 O.D. & ID 0.375	0.375	1.250	2.15
B125500	Type 'B' Bushing 1.250 O.D. & ID 0.500	0.500	1.250	2.15
B125625	Type 'B' Bushing 1.250 O.D. & ID 0.625	0.625	1.250	2.15
B125750	Type 'B' Bushing 1.250 O.D. & ID 0.750	0.750	1.250	2.15
B125875	Type 'B' Bushing 1.250 O.D. & ID 0.875	0.875	1.250	2.15
B125100	Type 'B' Bushing 1.250 O.D. & ID 1.000	1.000	1.250	2.15
B150375	Type 'B' Bushing 1.500 O.D. & ID 0.375	0.375	1.500	2.51
B150500	Type 'B' Bushing 1.500 O.D. & ID 0.500	0.500	1.500	2.51
B150625	Type 'B' Bushing 1.500 O.D. & ID 0.625	0.625	1.500	2.51
B150750	Type 'B' Bushing 1.500 O.D. & ID 0.750	0.750	1.500	2.51
B150875	Type 'B' Bushing 1.500 O.D. & ID 0.875	0.875	1.500	2.51
B150100	Type 'B' Bushing 1.500 O.D. & ID 1.000	1.000	1.500	2.51
B150125	Type 'B' Bushing 1.500 O.D. & ID 1.250	1.250	1.500	2.51
B175500	Type 'B' Bushing 1.750 O.D. & ID 0.500	0.500	1.750	3.00
B175625	Type 'B' Bushing 1.750 O.D. & ID 0.625	0.625	1.750	3.00
B175750	Type 'B' Bushing 1.750 O.D. & ID 0.750	0.750	1.750	3.00
B175875	Type 'B' Bushing 1.750 O.D. & ID 0.875	0.875	1.750	3.00
B175100	Type 'B' Bushing 1.750 O.D. & ID 1.000	1.000	1.750	3.00
B175125	Type 'B' Bushing 1.750 O.D. & ID 1.250	1.250	1.750	3.00
B175150	Type 'B' Bushing 1.750 O.D. & ID 1.500	1.500	1.750	3.00
B200500	Type 'B' Bushing 2.000 O.D. & ID 0.500	0.500	2.000	3.49
B200625	Type 'B' Bushing 2.000 O.D. & ID 0.625	0.625	2.000	3.49
B200750	Type 'B' Bushing 2.000 O.D. & ID 0.750	0.750	2.000	3.49
B200875	Type 'B' Bushing 2.000 O.D. & ID 0.875	0.875	2.000	3.49
B200100	Type 'B' Bushing 2.000 O.D. & ID 1.000	1.000	2.000	3.49
B200125	Type 'B' Bushing 2.000 O.D. & ID 1.250	1.250	2.000	3.49
B200150	Type 'B' Bushing 2.000 O.D. & ID 1.500	1.500	2.000	3.49
B200175	Type 'B' Bushing 2.000 O.D. & ID 1.750	1.750	2.000	3.49
B250750	Type 'B' Bushing 2.500 O.D. & ID 0.750	0.750	2.500	4.00
B250100	Type 'B' Bushing 2.500 O.D. & ID 1.000	1.000	2.500	4.00
B250125	Type 'B' Bushing 2.500 O.D. & ID 1.250	1.250	2.500	4.00
B250150	Type 'B' Bushing 2.500 O.D. & ID 1.500	1.500	2.500	4.00
B250175	Type 'B' Bushing 2.500 O.D. & ID 1.750	1.750	2.500	4.00
B250200	Type 'B' Bushing 2.500 O.D. & ID 2.000	2.000	2.500	4.00
B250225	Type 'B' Bushing 2.500 O.D. & ID 2.250	2.250	2.500	4.00

Hardware and Accessories

Tool Holder Bushing Type-J

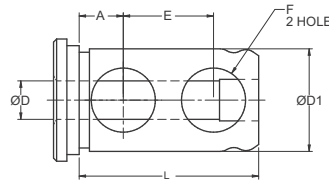

Catalog Number	Description	ØD (inch)	ØD1 (inch)	L (inch)	A (inch)	E (inch)	F (inch)
J750250	Type J Bushing .750OD x .250ID	0.250	0.750	1.50	0.375	0.810	0.375
J750312	Type J Bushing .750OD x .312ID	0.312	0.750	1.50	0.375	0.810	0.375
J750375	Type J Bushing .750OD x .375ID	0.375	0.750	1.50	0.375	0.810	0.375
J750500	Type J Bushing .750OD x .500ID	0.500	0.750	1.50	0.375	0.810	0.375
J100250	Type J Bushing 1.000OD x .250ID	0.250	1.000	1.75	0.437	0.880	0.625
J100312	Type J Bushing 1.000OD x .312ID	0.312	1.000	1.75	0.437	0.880	0.625
J100375	Type J Bushing 1.000OD x .375ID	0.375	1.000	1.75	0.437	0.880	0.625
J100500	Type J Bushing 1.000OD x .500ID	0.500	1.000	1.75	0.437	0.880	0.625
J100625	Type J Bushing 1.000OD x .625ID	0.625	1.000	1.75	0.437	0.880	0.625
J100750	Type J Bushing 1.000OD x .750ID	0.750	1.000	1.75	0.437	0.880	0.625
J125375	Type J Bushing 1.250OD x .375ID	0.375	1.250	2.13	0.625	1.000	0.625
J125500	Type J Bushing 1.250OD x .500ID	0.500	1.250	2.13	0.625	1.000	0.625
J125625	Type J Bushing 1.250OD x .625ID	0.625	1.250	2.13	0.625	1.000	0.625
J125750	Type J Bushing 1.250OD x .750ID	0.750	1.250	2.13	0.625	1.000	0.625
J125875	Type J Bushing 1.250OD x .875ID	0.875	1.250	2.13	0.625	1.000	0.625
J125100	Type J Bushing 1.250OD x 1.000ID	1.000	1.250	2.13	0.625	1.000	0.625
J150375	Type J Bushing 1.500OD x .375ID	0.375	1.500	2.50	0.687	1.130	0.875
J150500	Type J Bushing 1.500OD x .500ID	0.500	1.500	2.50	0.687	1.130	0.875
J150625	Type J Bushing 1.500OD x .625ID	0.625	1.500	2.50	0.687	1.130	0.875
J150750	Type J Bushing 1.500OD x .750ID	0.750	1.500	2.50	0.687	1.130	0.875
J150875	Type J Bushing 1.500OD x .875ID	0.875	1.500	2.50	0.687	1.130	0.875
J150100	Type J Bushing 1.500OD x 1.000ID	1.000	1.500	2.50	0.687	1.130	0.875
J150125	Type J Bushing 1.500OD x 1.250ID	1.250	1.500	2.50	0.687	1.130	0.875
J175500	Type J Bushing 1.750OD x .500ID	0.500	1.750	3.00	0.75	1.250	0.875
J175625	Type J Bushing 1.750OD x .625ID	0.625	1.750	3.00	0.75	1.250	0.875
J175750	Type J Bushing 1.750OD x .750ID	0.750	1.750	3.00	0.75	1.250	0.875
J175875	Type J Bushing 1.750OD x .875ID	0.875	1.750	3.00	0.75	1.250	0.875
J175100	Type J Bushing 1.750OD x 1.000ID	1.000	1.750	3.00	0.75	1.250	0.875
J175125	Type J Bushing 1.750OD x 1.250ID	1.250	1.750	3.00	0.75	1.250	0.875
J175150	Type J Bushing 1.750OD x 1.500ID	1.500	1.750	3.00	0.75	1.250	0.875
J200500	Type J Bushing 2.000OD x .500ID	0.500	2.000	3.50	0.75	1.500	1.000
J200625	Type J Bushing 2.000OD x .625ID	0.625	2.000	3.50	0.75	1.500	1.000
J200750	Type J Bushing 2.000OD x .750ID	0.750	2.000	3.50	0.75	1.500	1.000
J200875	Type J Bushing 2.000OD x .875ID	0.875	2.000	3.50	0.75	1.500	1.000
J200100	Type J Bushing 2.000OD x 1.000ID	1.000	2.000	3.50	0.75	1.500	1.000
J200125	Type J Bushing 2.000OD x 1.250ID	1.250	2.000	3.50	0.75	1.500	1.000
J200150	Type J Bushing 2.000OD x 1.500ID	1.500	2.000	3.50	0.75	1.500	1.000
J200175	Type J Bushing 2.000OD x 1.750ID	1.750	2.000	3.50	0.75	1.500	1.000
J250750	Type 'J' Bushing 2.500 O.D.& ID .7500	0.750	2.500	4.00	0.88	1.75	1.25
J250100	Type 'J' Bushing 2.500 O.D.& ID 1.000	1.000	2.500	4.00	0.88	1.75	1.25
J250125	Type 'J' Bushing 2.500 O.D. & ID 1.250	1.250	2.500	4.00	0.88	1.75	1.25
J250150	Type 'J' Bushing 2.500 O.D. & ID 1.500	1.500	2.500	4.00	0.88	1.75	1.25
J250175	Type 'J' Bushing 2.500 O.D. & ID 1.750	1.750	2.500	4.00	0.88	1.75	1.25
J250200	Type 'J' Bushing 2.500 O.D. & ID 2.000	2.000	2.500	4.00	0.88	1.75	1.25
J250225	Type 'J' Bushing 2.500 O.D. & ID 2.250	2.250	2.500	4.00	0.88	1.75	1.25

Hardware and Accessories

Tool Holder Bushing Type-Z

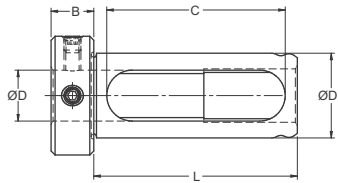

Catalog Number	Description	ØD (inch)	ØD1 (inch)	C (inch)	L (inch)	B (inch)
Z100250	Type Z Bushing 1.000OD x 0.250ID	0.250	1.000	2.380	2.750	0.500
Z100312	Type Z Bushing 1.000OD x 0.312ID	0.312	1.000	2.380	2.750	0.500
Z100375	Type Z Bushing 1.000OD x 0.375ID	0.375	1.000	2.380	2.750	0.500
Z100500	Type Z Bushing 1.000OD x 0.500ID	0.500	1.000	2.380	2.750	0.500
Z100625	Type Z Bushing 1.000OD x 0.625ID	0.625	1.000	2.380	2.750	0.500
Z100750	Type Z Bushing 1.000OD x 0.750ID	0.750	1.000	2.380	2.750	0.500
Z125375	Type Z Bushing 1.250OD x 0.375ID	0.375	1.250	2.630	3.000	0.625
Z125500	Type Z Bushing 1.250OD x 0.500ID	0.500	1.250	2.630	3.000	0.625
Z125625	Type Z Bushing 1.250OD x 0.625ID	0.625	1.250	2.630	3.000	0.625
Z125750	Type Z Bushing 1.250OD x 0.750ID	0.750	1.250	2.630	3.000	0.625
Z125875	Type Z Bushing 1.250OD x 0.875ID	0.875	1.250	2.630	3.000	0.625
Z125100	Type Z Bushing 1.250OD x 1.000ID	1.000	1.250	2.630	3.000	0.625
Z150375	Type Z Bushing 1.500OD x 0.375ID	0.375	1.500	2.800	3.250	0.75
Z150500	Type Z Bushing 1.500OD x 0.500ID	0.500	1.500	2.800	3.250	0.75
Z150625	Type Z Bushing 1.500OD x 0.625ID	0.625	1.500	2.800	3.250	0.75
Z150750	Type Z Bushing 1.500OD x 0.750ID	0.750	1.500	2.800	3.250	0.75
Z150875	Type Z Bushing 1.500OD x 0.875ID	0.875	1.500	2.800	3.250	0.75
Z150100	Type Z Bushing 1.500OD x 1.000ID	1.000	1.500	2.800	3.250	0.75
Z150125	Type Z Bushing 1.500OD x 1.250ID	1.250	1.500	2.800	3.250	0.75
Z175500	Type Z Bushing 1.750OD x 0.500ID	0.500	1.750	3.130	3.500	0.75
Z175625	Type Z Bushing 1.750OD x 0.625ID	0.625	1.750	3.130	3.500	0.75
Z175750	Type Z Bushing 1.750OD x 0.750ID	0.750	1.750	3.130	3.500	0.75
Z175875	Type Z Bushing 1.750OD x 0.875ID	0.875	1.750	3.130	3.500	0.75
Z175100	Type Z Bushing 1.750OD x 1.000ID	1.000	1.750	3.130	3.500	0.75
Z175125	Type Z Bushing 1.750OD x 1.250ID	1.250	1.750	3.130	3.500	0.75
Z175150	Type Z Bushing 1.750OD x 1.500ID	1.500	1.750	3.130	3.500	0.75
Z200500	Type Z Bushing 2.000OD x 0.500ID	0.500	2.000	3.130	3.750	0.75
Z200625	Type Z Bushing 2.000OD x 0.625ID	0.625	2.000	3.130	3.750	0.75
Z200750	Type Z Bushing 2.000OD x 0.750ID	0.750	2.000	3.130	3.750	0.75
Z200875	Type Z Bushing 2.000OD x 0.875ID	0.875	2.000	3.130	3.750	0.75
Z200100	Type Z Bushing 2.000OD x 1.000ID	1.000	2.000	3.130	3.750	0.75
Z200125	Type Z Bushing 2.000OD x 1.250ID	1.250	2.000	3.130	3.750	0.75
Z200150	Type Z Bushing 2.000OD x 1.500ID	1.500	2.000	3.130	3.750	0.75
Z200175	Type Z Bushing 2.000OD x 1.750ID	1.750	2.000	3.130	3.750	0.75
Z250750	Type 'Z' Bushing 2.500 O.D. & ID 0.750	0.750	2.500	3.880	4.250	1
Z250100	Type 'Z' Bushing 2.500 O.D. & ID 1.000	1.000	2.500	3.880	4.250	1
Z250125	Type 'Z' Bushing 2.500 O.D. & ID 1.250	1.250	2.500	3.880	4.250	1
Z250150	Type 'Z' Bushing 2.500 O.D. & ID 1.500	1.500	2.500	3.880	4.250	1
Z250175	Type 'Z' Bushing 2.500 O.D. & ID 1.750	1.750	2.500	3.880	4.250	1
Z250200	Type 'Z' Bushing 2.500 O.D. & ID 2.000	2.000	2.500	3.880	4.250	1
Z250225	Type 'Z' Bushing 2.500 O.D. & ID 2.250	2.250	2.500	3.880	4.250	1

Hardware and Accessories

Tool Holder Bushing Type-LBF

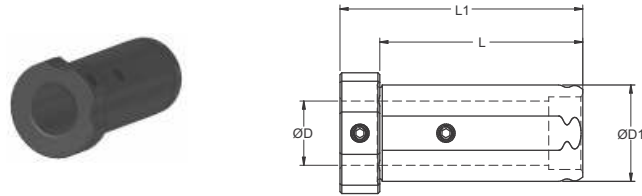

Catalog Number	Description	ØD (inch)	ØD1 (inch)	L1 (inch)	L (inch)
LBF 150250	Type LBF Bushing 1.50OD x .250ID	0.250	1.50	3.780	3.160
LBF 150375	Type LBF Bushing 1.50OD x .375ID	0.375	1.50	3.780	3.160
LBF 150500	Type LBF Bushing 1.50OD x .500ID	0.500	1.50	3.780	3.160
LBF 150625	Type LBF Bushing 1.50OD x .6250ID	0.625	1.50	3.780	3.160
LBF 150750	Type LBF Bushing 1.50OD x .750ID	0.750	1.50	3.780	3.160
LBF 150875	Type LBF Bushing 1.50OD x .8750ID	0.875	1.50	3.780	3.160
LBF 150100	Type LBF Bushing 1.50OD x 1.00ID	1.000	1.50	3.780	3.160
LBF 150125	Type LBF Bushing 1.50OD x 1.25ID	1.250	1.50	3.780	3.160

Tool Holder Bushing Type-LB

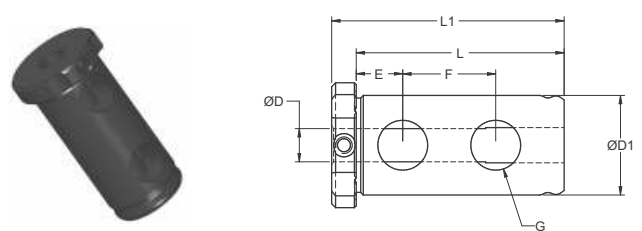

Catalog Number	Description	ØD (inch)	ØD1 (inch)	L1 (inch)	L (inch)	E (inch)	F (inch)	G (inch)
LB 150250	Type LB Bushing 1.50OD x .250ID	0.250	1.50	3.780	3.160	0.500	1.750	0.750
LB 150375	Type LB Bushing 1.50OD x .375ID	0.375	1.50	3.780	3.160	0.500	1.750	0.750
LB 150500	Type LB Bushing 1.50OD x .500ID	0.500	1.50	3.780	3.160	0.500	1.750	0.750
LB 150625	Type LB Bushing 1.50OD x .6250ID	0.625	1.50	3.780	3.160	0.500	1.750	0.750
LB 150750	Type LB Bushing 1.50OD x .750ID	0.750	1.50	3.780	3.160	0.500	1.750	0.750
LB 150875	Type LB Bushing 1.50OD x .8750ID	0.875	1.50	3.780	3.160	0.500	1.750	0.750
LB 150100	Type LB Bushing 1.50OD x 1.00ID	1.000	1.50	3.780	3.160	0.500	1.750	0.750
LB 150125	Type LB Bushing 1.50OD x 1.25ID	1.250	1.50	3.780	3.160	0.500	1.750	0.750

Hardware and Accessories

Retention Knobs

Machine Spindle	Brands
A	Hurco
B	DMG/Mori Seiki
C	Toyoda
D	Mazak
E	Okuma
F	Brother
G	Fanuc
I	Matsuura
H	Haas
J	OKK
K	Doosan
M	Kitamura
N	Makino
P	SNK
R	Yasda
S	Mitsui Seiki
T	Fadal
U	Ikegai
V	Victor
W	Kira
Y	Kia
Z	Toshiba

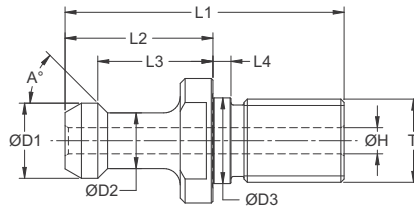

Figure-1

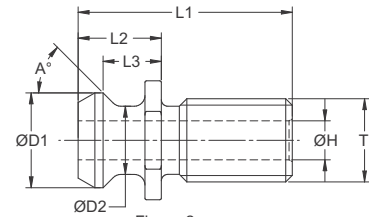

Figure-2

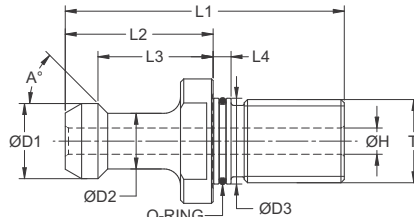

Figure-3

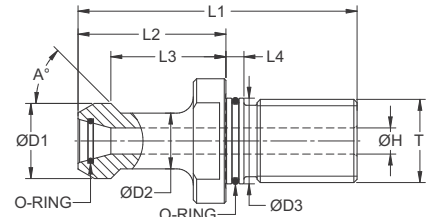

Figure-4

Catalog Number	Machine Spindle Taper	Coolant Hole Y/N	Fig.	A Pull Angle	ØD1 Head	ØD2 Neck	ØD3 Pilot Dia.	L4 Pilot Length	L1 OAL	L2 Proj.	L3 Pull Length	H Coolant Hole	Flats	T Knob Thread	Machine Spindle
9610450102	BT30	N		45	0.520	0.385			1.100	0.460	0.320	N	13mm	M12	A
9610450105	BT30	N	1	45	0.433	0.276	0.492	0.157	1.683	0.906	0.709	N	13mm	M12	G, H, J
9610600105	BT30	N	1	60	0.433	0.276	0.492	0.157	1.683	0.906	0.709	N	13mm	M12	B, E, F, I
9610900105	BT30	N	1	90	0.549	0.313	0.492	0.157	1.770	0.906	0.709	N	13mm	M12	
9612450207	BT40	N	1	45	0.591	0.394	0.669	0.236	2.362	1.378	1.102	N	19mm	M16	A,E,J,M,C,E,H,N
9612600207	BT40	N	1	60	0.591	0.394	0.669	0.236	2.360	1.378	1.102	N	19mm	M16	E
9612750206	BT40	N	1	75	0.748	0.551	0.669	0.236	2.126	1.142	0.906	N	19mm	M16	E, I, K, N, R
9612900205	BT40	N	1	90	0.591	0.394	0.669	0.236	2.126	0.980	0.709	N	19mm	M16	S
9612900207	BT40	N	1	90	0.591	0.394	0.669	0.236	2.360	1.378	1.102	N	19mm	M16	B, J, T
9624450703	CAT40	N	2	45	0.740	0.490	-	-	1.624	0.640	0.440	N	19mm	5/8"-11	D, E
9624450706	CAT40	N	1	45	0.591	0.394	0.641	0.177	2.250	1.266	0.990	N	19mm	5/8"-11	A,C,E,H,J,K
9624600706	CAT40	N	1	60	0.591	0.394	0.512		2.250	1.266	0.990	N	19mm	5/8"-11	
9624750705	CAT40	N	1	75	0.748	0.551	0.641	0.177	2.010	1.024	0.787	N	19mm	5/8"-11	I, K, M, N
9624900706	CAT40	N	1	90	0.591	0.394	0.641	0.177	2.244	1.260	0.984	N	19mm	5/8"-11	B, J
9626450905	CAT50	N	2	45	1.140	0.820	-	-	2.300	1.000	0.700	N	1.250	1"-8	A, N
9626450909	CAT50	N	1	45	0.906	0.669	1.031	0.217	3.354	1.780	1.386	N	30mm	1"-8	H, M
9626600909	CAT50	N	1	60	0.906	0.669	1.024	0.217	3.248	1.772	1.378	N	30mm	1"-8	I, P
9626900909	CAT50	N	1	90	0.906	0.669	1.031	0.217	3.346	1.780	1.386	N	30mm	1"-8	B, E, J
9610450105C	BT30	Y	1	45	0.433	0.276	0.492	0.157	1.683	0.906	0.709	0.118	13mm	M12	G, H, J
9610450105CO	BT30	Y	3	45	0.433	0.276	0.492	0.157	1.683	0.906	0.709	0.118	13mm	M12	B
9610600105C	BT30	Y	1	60	0.433	0.276	0.492	0.157	1.683	0.906	0.709	0.118	13mm	M12	B, E, F, I
9610750105C	BT30	Y	1	75	0.471	0.313	0.492	0.157	1.683	0.920	0.723	0.118	13mm	M12	R
9610900105C	BT30	Y	1	90	0.549	0.313	0.492	0.157	1.770	0.906	0.709	0.118	13mm	M12	
9612450204C	BT40	Y	1	45	0.740	0.490	0.669	0.236	1.736	0.752	0.552	0.276	19mm	M16	D
9612450207C	BT40	Y	1	45	0.591	0.394	0.669	0.236	2.360	1.378	1.102	0.197	19mm	M16	A,E,J,M,C,E,H,N
9612750206C	BT40	Y	1	75	0.748	0.551	0.669	0.236	2.126	1.142	0.906	0.236	19mm	M16	E, I, K, N, R
9624450703C	CAT40	Y	2	45	0.740	0.490	-	-	1.624	0.640	0.440	0.157	19mm	5/8"-11	D, E
9624450706C	CAT40	Y	1	45	0.591	0.394	0.641	0.177	2.250	1.266	0.990	0.200	19mm	5/8"-11	A,C,E,H,J,K
9624750705C	CAT40	Y	1	75	0.748	0.551	0.641	0.177	2.010	1.024	0.787	0.236	19mm	5/8"-11	I, K, M, N
9624750705C-2O	CAT40	Y	4	75	0.748	0.551	0.641	0.177	2.010	1.024	0.787	0.236	19mm	5/8"-11	K (HP)*
9624750705CO	CAT40	Y	3	75	0.748	0.551	0.641	0.177	2.010	1.024	0.787	0.236	19mm	5/8"-11	B
9624900706C	CAT40	Y	1	90	0.591	0.394	0.641	0.177	2.244	1.260	0.984	0.200	19mm	5/8"-11	B, J
9626450905COP	CAT50	Y	3	45	1.140	0.820	1.031	0.240	2.575	1.000	0.700	0.468	1.250	1"-8	A, C, D, N
9626450905CP	CAT50	Y	1	45	1.140	0.820	1.031	0.240	2.575	1.000	0.700	0.468	1.250	1"-8	A, C, D, N
9626450909C	CAT50	Y	1	45	0.906	0.669	1.031	0.217	3.354	1.780	1.386	0.312	30mm	1"-8	H, M
9626450909CO	CAT50	Y	3	45	0.906	0.669	1.031	0.217	3.354	1.780	1.386	0.312	30mm	1"-8	C
9626600909CO	CAT50	Y	3	60	0.906	0.669	1.024	0.217	3.508	1.772	1.378	0.312	30mm	1"-8	E
9626750907C	CAT50	Y	1	75	1.102	0.826	1.031	0.217	2.919	1.344	0.990	0.315	30mm	1"-8	I, K
9626900906C	CAT50	Y	1	90	0.942	0.706	1.031	0.217	2.519	1.218	0.903	0.315	1.250	1"-8	K (HP)*
9626900909C	CAT50	Y	1	90	0.906	0.669	1.031	0.217	3.346	1.780	1.386	0.312	30mm	1"-8	B, E, J
9626900909C-2O	CAT50	Y	4	90	0.906	0.669	1.031	0.217	3.346	1.780	1.386	0.312	30mm	1"-8	B, E, J (HP)*

Note: Machine Tool Builders change retention knob specifications from time to time. C = COOLANT THRU, O = 1 O-RING, 2O = 2 O-RING
 Always double check the required dimensions of the retention knob you require. * HP - High Pressure Coolant spindles.

Hardware and Accessories

Retention Knobs

Machine Spindle	Brands
A	Hurco
B	DMG/Mori Seiki
C	Toyoda
D	Mazak
E	Okuma
F	Brother
G	Fanuc
I	Matsuura
H	Haas
J	OKK
K	Doosan
M	Kitamura
N	Makino
P	SNK
R	Yasda
S	Mitsui Seiki
T	Fadal
U	Ikegai
V	Victor
W	Kira
Y	Kia
Z	Toshiba

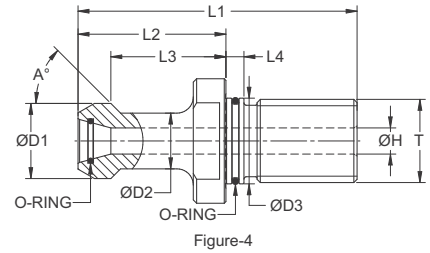
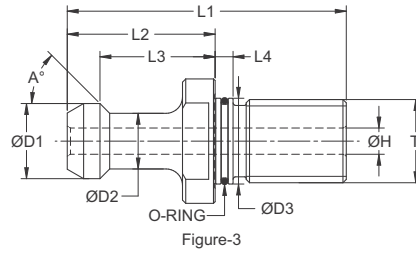
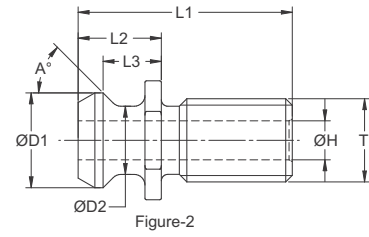
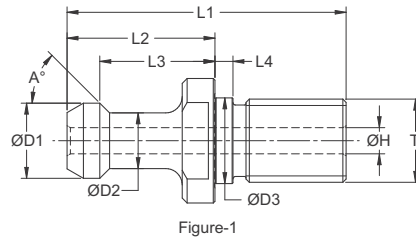

Catalog Number	Machine Spindle Taper	Coolant Hole Y/N	Fig.	A Pull Angle	ØD1 Head	ØD2 Neck	ØD3 Pilot Dia.	L4 Pilot Length	L1 OAL	L2 Proj.	L3 Pull Length	H Coolant Hole	Flats	T Knob Thread	Machine Spindle
9610450102C	BT30	Y	2	45	0.520	0.385	-	-	1.100	0.460	0.320	0.118	13mm	M12	A
9610450102P	BT30	N	1	45	0.520	0.385	0.492	0.157	1.385	0.460	0.320	N	13mm	M12	A
9610450102CP	BT30	Y	1	45	0.520	0.385	0.492	0.157	1.385	0.460	0.320	0.118	13mm	M12	A
9612450203C	BT40	Y	1	45	0.740	0.490	0.669	0.236	1.654	0.640	0.440	0.197	19mm	M16	A
9612450207CO	BT40	Y	3	45	0.591	0.394	0.669	0.236	2.362	1.378	1.102	0.197	19mm	M16	U
9612600207C	BT40	Y	1	60	0.591	0.394	0.669	0.236	2.362	1.378	1.102	0.197	19mm	M16	W
9612900207C	BT40	Y	1	90	0.591	0.394	0.669	0.236	2.362	1.378	1.102	0.197	19mm	M16	Y
9624450703CO	CAT40	Y	3	45	0.740	0.490	0.641	0.177	1.624	0.640	0.440	0.157	19mm	5/8"-11	D (HP)*
9624600706C	CAT40	Y	1	60	0.591	0.394	0.641	0.177	2.250	1.266	0.990	0.200	19mm	5/8"-11	C, Z
9626600909C	CAT50	Y	1	60	0.906	0.669	1.024	0.217	3.354	1.772	1.378	0.315	30mm	1"-8	E
9618150105	SK30	N	1	75	13mm	9mm	13mm	5mm	44mm	24mm	19mm	N	14mm	M12	P
9618150105C	SK30	Y	1	75	13mm	9mm	13mm	5mm	44mm	24mm	19mm	3mm	14mm	M12	P
9619150205	SK40	N	1	75	19mm	14mm	17mm	7mm	54mm	26mm	20mm	N	19mm	M16	SK40
9619150205C	SK40	Y	1	75	19mm	14mm	17mm	7mm	54mm	26mm	20mm	7mm	19mm	M16	SK40
9621150407	SK50	N	1	75	28mm	21mm	25mm	10mm	74mm	34mm	25mm	N	30mm	M24	P
9621150407C	SK50	Y	-	75	28mm	21mm	25mm	10mm	74mm	34mm	25mm	11.5mm	30mm	M24	P

C = COOLANT THRU, O = 1 O-RING, 2O = 2 O-RING
 * HP - High Pressure Coolant spindles.

Note: Machine Tool Builders change retention knob specifications from time to time. Always double check the required dimensions of the retention knob you require.

Hardware and Accessories

HSK Coolant Tubes

For HSK Holders 32 - 125 Tapers

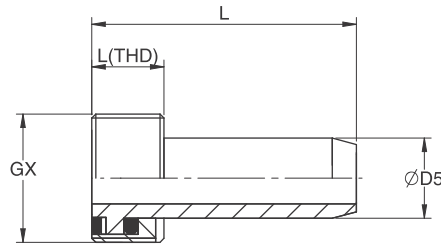

Catalog Number	Description	GX (mm)	L (mm)	ØD5 (mm)	Torque for holder Assembly Nm/In Lbs.
9697110CB	HSK32 Tube	M10x1	26.70	6	7Nm/
9697212CB	HSK40 Tube	M12x1	29.5	8	11Nm/
9697316CB	HSK50 Tube	M16x1	33.20	10	15Nm/
9697418CB	HSK63 Tube	M18x1	36.60	12	20Nm/
9697520CB	HSK80 Tube	M20x1.5	40.10	14	25Nm/
9697624CB	HSK100 Tube	M24x1.5	44.2	16	30Nm/
9697730CB	HSK125 Tube	M30X1.5	48.0	18	35Nm/

Coolant Tube Wrenches on page 160

Assembly instructions for the Coolant Tube internal taper shank of HSK holders

- 1) Shank must be clean of all machining debris
- 2) Add lubricant (light grease) to O-Ring before assembly
- 3) Completely insert the Coolant tube centrally in HSK
- 4) Screw in the coolant tube using the proper installation wrench
- 5) Check the coolant tube for radial movement - should be none
- 6) Check the coolant tube for axial movement - should be none
- 7) Standard coolant tubes are supplied in a brass material. Steel coolant tubes are available in HSK63, HSK80, and HSK100 sizes. Add "S" to end of part number

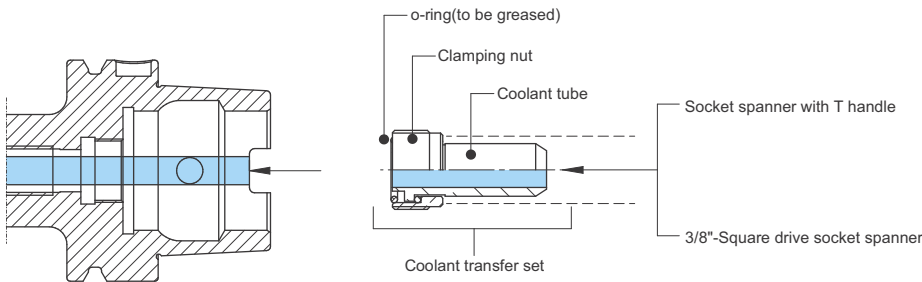

PTI Coolant Tubes

For PTI Holders 63 & 80 Tapers

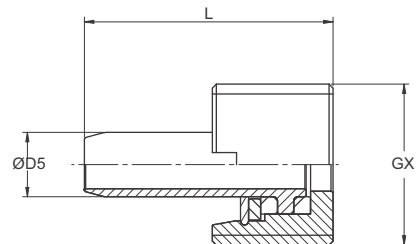

Catalog Number	Description	GX (mm)	L (mm)	ØD5 (mm)
966920C	PTI63 Tube	M20x2.0	31.0	8
967020C	PTI80 Tube	M20x2.0	33.5	10

Hardware and Accessories

Length Adjustment Screws for ER Collet Chucks

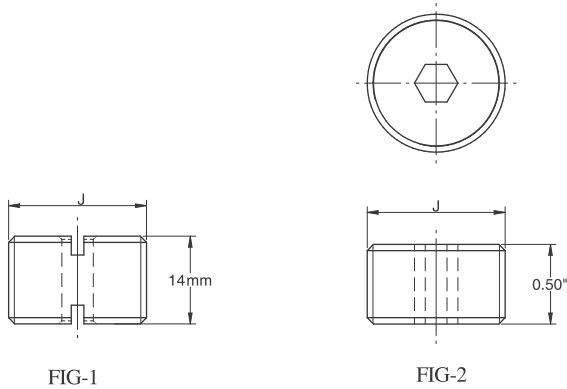

Catalog Number	J	Fig.
87922081	M8X1.25	1
87922111	M10X1.50	1
87922110	M12X1.75	1
87922161	M12X1.75	1
87922160	M16X2.00	1
87922201	M18X1.50	1
87922200	M22X1.50	1
87922250	M28X1.50	1

Catalog Number	Description	ER Collet Chuck Size	J	Fig.
87922794	ER11 - .250	ER11	5/16"-24 LH	2
87922437	ER16 - .437	ER16	7/16"-16 LH	2
87922563	ER20 - .562	ER20	9/16"-16 LH	2
87922688	ER25 - .687	ER25	11/16"-16 LH	2
87922875	ER32 - .875	ER32	7/8"-16 LH	2
87922112	ER40 - 1.125	ER40	1-1/8"-16 LH	2

"Y" Spanner Wrenches for AccuMill™ Multi-Milling Chucks

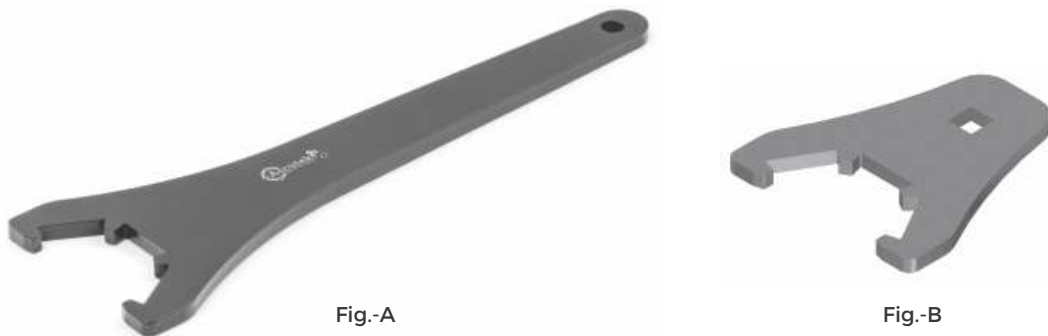

Catalog Number	Description	Milling Chuck Size	L (mm)	Fig.
87922320	MMC 75 Spanner	20mm/.750"	250	A
87922400	MMC 125 Spanner	32mm/1.250"	287	A
87922329	MMC 75 "Y" Claw Wrench	20mm/.750"	85	B
87922409	MMC 125 "Y" Claw Wrench	32mm/1.250"	104.5	B

Torque Wrench for Multi-Milling Chucks

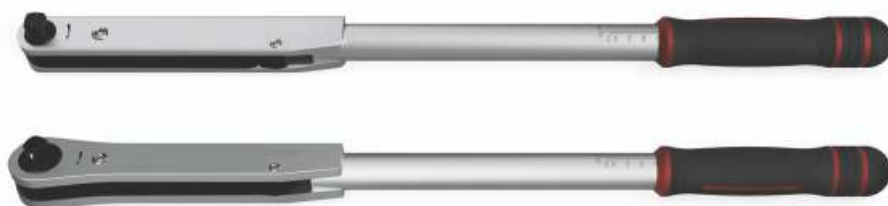

Catalog Number	Description	Milling Chuck Size	Range (Nm)
87932065	Torque Wrench 3/8" Sq. Drive	20mm/.750"	65
87940155	Torque Wrench 1/2" Sq. Drive	32mm/1.250"	155

Hardware and Accessories

Shell Mill Arbor Screws

For use with Shell Mill holders – Standard and AccuKool™ style

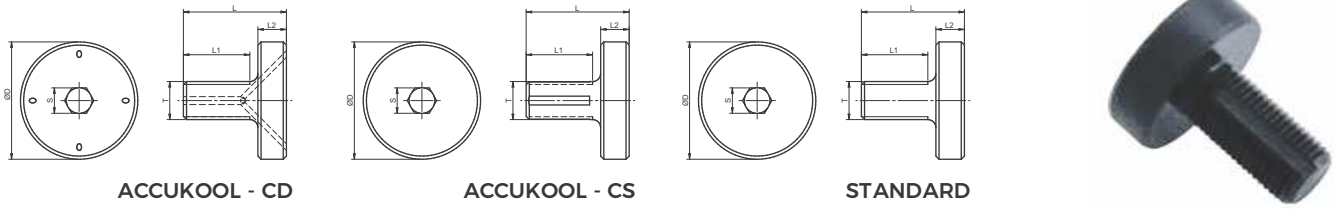

	Catalog Number	Description	Style	Cutter Pilot Size	ØD	L	L1	L2	T	Key
Inch	9615006	SMLS-050	Standard	0.50	0.656	1.34	1.0	0.34	1/4"-28	3/16"
	9615006CS	SMLS-CS-050	AccuKool	0.50	0.656	1.34	1.0	0.34	1/4"-28	3/16"
	9615006CD	SMLS-CD-050	AccuKool	0.50	0.656	1.38	1.0	0.38	1/4"-28	3/16"
	9615006-SM	SMLS-050-SM	Small Head Standard	0.50	0.394	1.34	1.0	0.34	1/4"-28	3/16"
	9615006CS-SM	SMLS-CS-050-SM	Small Head AccuKool	0.50	0.394	1.34	1.0	0.34	1/4"-28	3/16"
	9615006CD-SM	SMLS-CD-050-SM	Small Head AccuKool	0.50	0.394	1.38	1.0	0.38	1/4"-28	3/16"
	9617507	SMLS-075	Standard	0.75	0.875	1.8	1.43	0.37	3/8"-24	1/4"
	9617507CS	SMLS-CS-075	AccuKool	0.75	0.875	1.8	1.43	0.37	3/8"-24	1/4"
	9617507CD	SMLS-CD-075	AccuKool	0.75	0.875	1.8	1.37	0.43	3/8"-24	1/4"
	9617507-SM	SMLS-075-SM	Small Head Standard	0.75	0.625	1.8	1.43	0.37	3/8"-24	1/4"
	9617507CS-SM	SMLS-CS-075-SM	Small Head AccuKool	0.75	0.625	1.8	1.43	0.37	3/8"-24	1/4"
	9617507CD-SM	SMLS-CD-075-SM	Small Head AccuKool	0.75	0.625	1.8	1.30	0.50	3/8"-24	1/4"
	9611008	SMLS-100	Standard	1.00	1.19	1.62	1.25	0.37	1/2"-20	5/16"
	9611008CS	SMLS-CS-100	AccuKool	1.00	1.19	1.62	1.25	0.37	1/2"-20	5/16"
	9611008CD	SMLS-CD-100	AccuKool	1.00	1.19	1.68	1.25	0.43	1/2"-20	5/16"
	9611008-SM	SMLS-100-SM	Small Head Standard	1.00	0.750	1.62	1.25	0.37	1/2"-20	5/16"
	9611008CS-SM	SMLS-CS-100-SM	Small Head AccuKool	1.00	0.750	1.62	1.25	0.37	1/2"-20	5/16"
	9611008CD-SM	SMLS-CD-100-SM	Small Head AccuKool	1.00	0.750	1.70	1.20	0.50	1/2"-20	5/16"
	9611209	SMLS-125	Standard	1.25	1.50	1.44	0.94	0.50	5/8"-18	5/16"
	9611209CS	SMLS-CS-125	AccuKool	1.25	1.50	1.44	0.94	0.50	5/8"-18	5/16"
	9611209CD	SMLS-CD-125	AccuKool	1.25	1.50	1.49	0.94	0.55	5/8"-18	5/16"
	9611209-SM	SMLS-125-SM	Small Head Standard	1.25	0.940	1.44	0.94	0.50	5/8"-18	5/16"
	9611209CS-SM	SMLS-CS-125-SM	Small Head AccuKool	1.25	0.940	1.44	0.94	0.50	5/8"-18	5/16"
	9611209CD-SM	SMLS-CD-125-SM	Small Head AccuKool	1.25	0.940	1.54	1.00	0.56	5/8"-18	5/16"
	9611510	SMLS-150	Standard	1.50	1.875	1.63	1.13	0.50	3/4"-16	3/8"
	9611510CS	SMLS-CS-150	AccuKool	1.50	1.875	1.63	1.13	0.50	3/4"-16	3/8"
	9611510CD	SMLS-CD-150	AccuKool	1.50	1.875	1.68	1.13	0.55	3/4"-16	3/8"
	9612011	SMLS-200	Standard	2.00	2.40	1.81	1.31	0.50	1"-14	1/2"
	9612011CS	SMLS-CS-200	AccuKool	2.00	2.40	1.81	1.31	0.50	1"-14	1/2"
	9612011CD	SMLS-CD-200	AccuKool	2.00	2.40	1.88	1.33	0.55	1"-14	1/2"
9612511	SMLS-250	AccuKool	2.50	3.10	2.00	1.5	0.50	1"-14	1/2"	
9612511CS	SMLS-CS-250	AccuKool	2.50	3.10	2.00	1.5	0.50	1"-14	1/2"	
9612511CD	SMLS-CD-250	AccuKool	2.50	3.10	2.05	1.5	0.55	1"-14	1/2"	
Metric	9611601	SMLS-16M	Standard	16mm	13mm	33mm	25mm	8mm	M8X1.25	6mm
	9612202	SMLS-22M	Standard	22mm	16mm	35mm	25mm	10mm	M10X1.5	8mm
	9612202CS	SMLS-CS-22M	AccuKool	22mm	28mm	25mm	18mm	7mm	M10X1.5	8mm
	9612202CD	SMLS-CD-22M	AccuKool	22mm	28mm	25mm	18mm	7mm	M10X1.5	8mm
	9612703	SMLS-27M	Standard	27mm	18mm	47mm	35mm	12mm	M12X1.75	10mm
	9612703CS	SMLS-CS-27M	AccuKool	27mm	35mm	30mm	22mm	8mm	M12X1.75	10mm
	9612703CD	SMLS-CD-27M	AccuKool	27mm	35mm	30mm	22mm	8mm	M12X1.75	10mm
	9613204	SMLS-32M	Standard	32mm	24mm	51mm	35mm	16mm	M16X2.00	14mm
	9613204CS	SMLS-CS-32M	AccuKool	32mm	42mm	35mm	26mm	9mm	M16X2.00	14mm
	9613204CD	SMLS-CD-32M	AccuKool	32mm	42mm	35mm	26mm	9mm	M16X2.00	14mm
	9614005	SMLS-40M	Standard	40mm	30mm	55mm	35mm	20mm	M20X2.5	17mm
	9614005CS	SMLS-CS-40M	AccuKool	40mm	52mm	45mm	30mm	15mm	M20X2.5	17mm
9614005CD	SMLS-CD-40M	AccuKool	40mm	52mm	40mm	30mm	15mm	M20X2.5	17mm	

NOTE:

CD Style Arbor Screw features coolant thru the arbor screw and exiting thru the face of the arbor screw.

CS Style Arbor Screw features coolant slots along the threads of the arbor screw and into then body of the Coolant-thru Cutter

Hardware and Accessories

Tool Shank Holding Fixtures

For tool setup

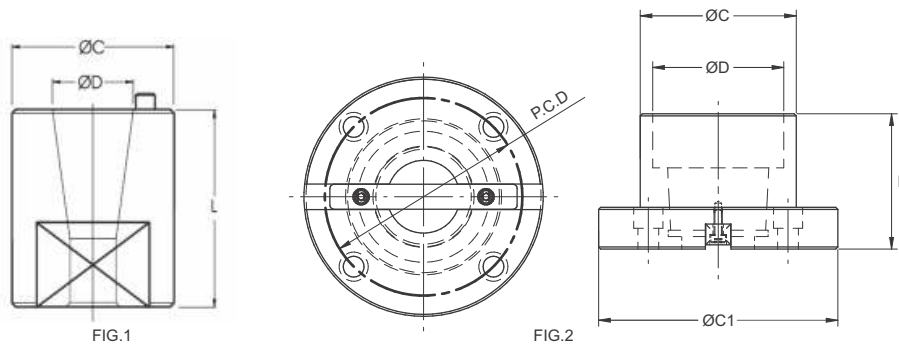

Catalog Number	Description	ØD (mm)	C (mm)	C (mm)	L (mm)	PCD (mm)	Fig. No.
952030	HF 30 Taper	31.75	70	-	75	-	1
952040	HF 40 Taper	44.45	75	-	100	-	1
952050	HF 50 Taper	69.85	100	-	135	-	1
952A40	HF HSK 40 Taper	40	50	100	50	90	2
952A50	HF HSK 50 Taper	50	60	115	60	95	2
952A63	HF HSK 63 Taper	63	75	115	65	95	2
952A10	HF HSK 100 Taper	100	105	170	95	140	2
952P50	HF PTI 50 Taper	-	70	115	75	95	1
952P63	HF PTI 63 Taper	-	80	115	85	95	1
952P80	HF PTI 80 Taper	-	100	170	100	140	1

ER Nut Wrenches

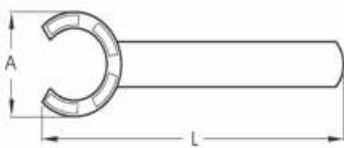

ER 8M/11M/16M/20M



ER 11/16/20

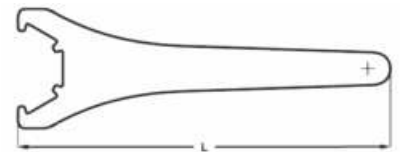

ER 25/32/40

Catalog Number	Description	Collet Size and Type	A (mm)	L (mm)
87922081	ER8M-Spanner	ER8M	13.0	75
87922111	ER11M-Spanner	ER11M	16.8	90
87922110	ER11-C-Spanner	ER11	32.0	95
87922161	ER16M-Spanner	ER16M	22.5	110
87922160	ER16-C-Spanner	ER16	42.0	140
87922201	ER20M-Spanner	ER20M	29.0	120
87922200	ER20-C-Spanner	ER20	60.0	135
87922250	ER25-Y-Spanner	ER25	-	205
87922320	ER32- Y-Spanner	ER32	-	250
87922400	ER40- Y-Spanner	ER40	-	287

ERZ Nut Spanner

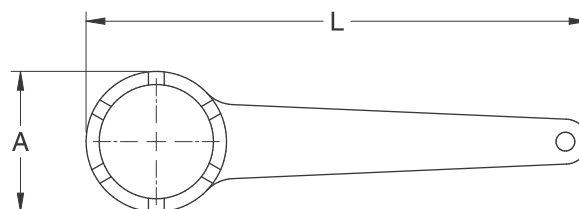

Catalog Number	Description	ØD (mm)	C (mm)	L (mm)
87922160Z	ERZ16 Spanner	ERZ16	22	97
87922200Z	ERZ20 Spanner	ERZ20	25.5	97
87922250Z	ERZ25 Spanner	ERZ25	30	134
87922320Z	ERZ32 Spanner	ERZ32	37.5	134
87922400Z	ERZ40 Spanner	ERZ40	47	150

Hardware and Accessories

ER Torque Wrench Handles

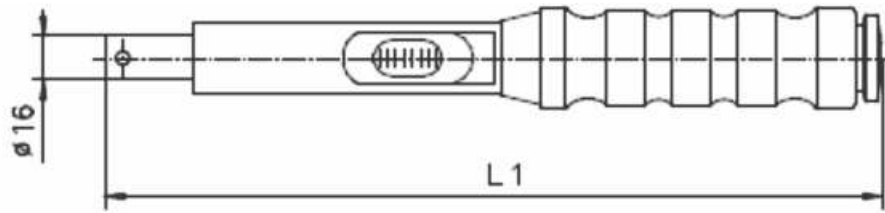

Catalog Number	Description	ER Collet Size	Range		L1 (mm)
			Nm	Ft-lbs.	
99010811	Mini-Torque	ER8/ER11	5--50	3.7--37	335
99011620	Small Torque	ER16/ER20	5--50	5.9-44	300
99012532	Medium Torque	ER25/ER32	20-100	14.8-73.8	340
99014050	Large Torque	ER40/ER50	60-300	44.3-221	545

HSK Coolant Tube Wrenches

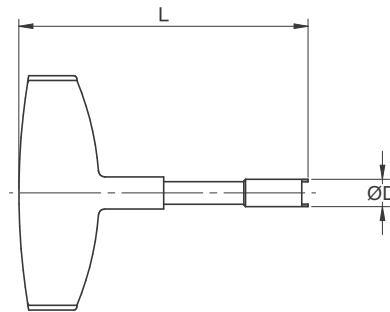

Catalog Number	Description	HSK Taper Size	ϕD (mm)	L (mm)
CTS7110C	HSKA/E 32 CTW	HSKA/E 32	8.50	120
CTS7212C	HSKA/E 40 CTW	HSKA/E 40	10.50	120
CTS7316C	HSKA/E 50 CTW	HSKA/E 50	14.50	120
CTS7418C	HSKA/E 63 CTW	HSKA/E 63	16.50	120
CTS7520C	HSKA/E 80 CTW	HSKA/E 80	18.50	130
CTS7624C	HSKA/E 100 CTW	HSKA/E 100	22.5	130
CTS7730C	HSKA/E 125 CTW	HSKA/E 125	ON REQUEST	ON REQUEST

Torque Wrench for AccuClamp™ Hydraulic Chuck



Catalog Number	Description	Range	
		Nm	Ft-lbs.
87924H20	HCS-0.75 / 20	5.5	4.00
87924H32	HCS-1.250 / 32	6.0	4.34

Hardware and Accessories

Spindle Taper Wipers

In today's environment of absolute precision, one of the biggest problems with accuracy is at the point of the tool coupling. The slightest ingress of dirt can give you run out, changes in length and general problems with repeatability. To combat this, all Spindles should be cleaned daily with taper cleaners. Spindle and taper cleaning tools can be supplied for your specific machine and tool holder tapers.

Robust construction with high oil and grease resistance.

- Plastic injection molded core with fluted location for cleaning strips ensures accurate sizing and cleaning efficiency.
- Cleaning strips will maintain adhesion to the taper core due to inset location even under scrubbing action.
- Cleaning strips at well-spaced intervals to move quite large residual partials.



Steep Taper Spindle Wipers

Catalog Number	Description
99150030	30 Taper Wipe
99150035	35 Taper Wipe
99150040	40 Taper Wipe
99150050	50 Taper Wipe



HSK Taper Spindle Wipers

Catalog Number	Description
99120032	HSK32 Wipe
99120040	HSK40 Wipe
99120050	HSK50 Wipe
99120063	HSK63 Wipe
99120080	HSK80 Wipe
99120100	HSK100 Wipe
99120125	HSK125 Wipe



Polygon Spindle-Wiper

Catalog Number	Description
99100030	PTI30 Wipe
99100040	PTI40 Wipe
99100050	PTI50 Wipe
99100063	PTI63 Wipe
99100080	PTI80 Wipe
99100100	PTI100 Wipe



HSK Taper Wipers

Catalog Number	Description
99130032	HSK32 Taper Wipe
99130040	HSK40 Taper Wipe
99130050	HSK50 Taper Wipe
99130063	HSK63 Taper Wipe
99130080	HSK80 Taper Wipe
99130100	HSK100 Taper Wipe
99130125	HSK125 Taper Wipe



ER Collet Taper Wiper

Catalog Number	Description
99400020	ER20 Wipe
99400025	ER25 Wipe
99400032	ER32 Wipe
99400040	ER40 Wipe
99400050	ER50 Wipe



Face Contact Tool Taper Wiper

Catalog Number	Description
99110030	BTP30 Taper Wipe
99110040	BTP40 Taper Wipe
99110050	BTP50 Taper Wipe
99140040	CATP40 Taper Wipe
99140050	CATP50 Taper Wipe

Work holding

DP – Dust Proof- Self Centering Chucks



The Accutek Dust Proof Scroll Operated Self Centering Chuck is the result of continuous Research & Development by our team committed to solving work holding problems.

Our Dust Proof chucks have been developed for mass production workshops where dust causes periodic breakdowns in chucks, thus reducing productivity. This new design of scroll operated self-centering chuck has serrated base jaws mountable with reversible Top Hard Jaws or Top Soft Jaws (both Top Hard Jaws and Top Soft Jaws are standard accessories with the chuck). The serrated base jaws have a limited movement and are also sealed against any dust entry into the chuck. Therefore, the life of our Dust Proof Chucks is increased by 60% and the loss in productivity due to more frequent cleaning is reduced.

FEATURES

- Body: Semi-Steel body with jaw ways hardened and ground
- Jaws: Teeth are precision ground from both sides
- Scroll: Threads are precision ground from both sides. 40-45 HRC.

Catalog Number	Description	Chuck Size (mm/inch)	Jaw Style
160DP3	6" Dust Proof; Serrated jaw (2 piece type); 3 jaw; Plain Back; Semi-Steel Body	160mm/6"	2pc Master/Top
200DP3	8" Dust Proof; Serrated jaw (2 piece type); 3 jaw; Plain Back; Semi-Steel Body	200mm/8"	2pc Master/Top
250DP3	10" Dust Proof; Serrated jaw (2 piece type); 3 jaw; Plain Back; Semi-Steel Body	250mm/10"	2pc Master/Top
315DP3	12" Dust Proof; Serrated jaw (2 piece type); 3 jaw; Plain Back; Semi-Steel Body	315mm/12"	2pc Master/Top

AD – AccuTru™- Self Centering Chucks



FEATURES

- Body: Forged Steel body with jaw ways hardened and ground
- Jaws: Teeth are precision ground from both sides
- Scroll: Threads are precision ground from both sides
 - o Hardness 40-45 Hrc
- Parts interchangeable with Bison Chucks
- Runout: Less than 0.0016" for chucks greater than 6" Dia.

	Catalog Number	Description	Chuck Size d1 (mm/inch)	Jaw Style
3 Jaw	B125AD3S	5" Bison style; Adjustable - Set Tru; 3-jaw; Steel Body Chuck	125mm/5"	2pc Master/Top
	B160AD3S	6" Bison style; Adjustable - Set Tru; 3-jaw; Steel Body Chuck	160mm/6"	2pc Master/Top
	B200AD3S	8" Bison style; Adjustable - Set Tru; 3-jaw; Steel Body Chuck	200mm/8"	2pc Master/Top
	B250AD3S	10" Bison style; Adjustable - Set Tru; 3-jaw; Steel Body Chuck	250mm/10"	2pc Master/Top
	B315AD3S	12" Bison style; Adjustable - Set Tru; 3-jaw; Steel Body Chuck	315mm/12"	2pc Master/Top
	B400AD3S	15" Bison style; Adjustable - Set Tru; 3-jaw; Steel Body Chuck	400mm/15"	2pc Master/Top
6 Jaw	B160AD6S	6" Bison style; Adjustable - Set Tru; 6-jaw; Steel Body Chuck	125mm/5"	2pc Master/Top
	B200AD6S	8" Bison style; Adjustable - Set Tru; 6-jaw; Steel Body Chuck	160mm/6"	2pc Master/Top
	B250AD6S	10" Bison style; Adjustable - Set Tru; 6-jaw; Steel Body Chuck	200mm/8"	2pc Master/Top
	B315AD6S	12" Bison style; Adjustable - Set Tru; 6-jaw; Steel Body Chuck	250mm/10"	2pc Master/Top
	B400AD6S	15" Bison style; Adjustable - Set Tru; 6-jaw; Steel Body Chuck	315mm/12"	2pc Master/Top

Work holding

MTJ – Master & Top Jaw - Self Centering Chucks



MTJ3

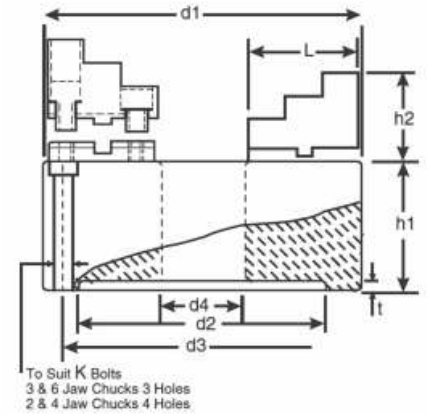

FEATURES

- Jaw ways hardened and ground
- Jaws: Teeth are precision ground from both sides
- Scroll: Threads are precision ground from both sides
 - o Hardness 40-45 Hrc
- Parts interchangeable with Bison Chucks
- Runout: Less than 0.0016" for chucks greater than 6" Dia.

	Catalog Number	Description	Chuck Size d1 (mm/inch)	Jaw Style	d2 (mm)	d3 (mm)	d4 (mm)	h1 (mm)	h2 (mm)	K (mm)
3 Jaw	B125MTJ3	5" 3-jaw Self Centering Master Jaw Scroll Chuck; Semi-Steel Body	125mm/5"	2pc Master/Top	95	108	33	56	40	M8
	B160MTJ3	6" 3-jaw Self Centering Master Jaw Scroll Chuck; Semi-Steel Body	160mm/6"	2pc Master/Top	125	140	42	65	40	M10
	B200MTJ3	8" 3-jaw Self Centering Master Jaw Scroll Chuck; Semi-Steel Body	200mm/8"	2pc Master/Top	160	176	55	75	44	M10
	B250MTJ3	10" 3-jaw Self Centering Master Jaw Scroll Chuck; Semi-Steel Body	250mm/10"	2pc Master/Top	200	224	76	85	54	M12
	B315MTJ3	12" 3-jaw Self Centering Master Jaw Scroll Chuck; Semi-Steel Body	315mm/12"	2pc Master/Top	260	286	103	94	57	M12
	B400MTJ3	15" 3-jaw Self Centering Master Jaw Scroll Chuck; Semi-Steel Body	400mm/15"	2pc Master/Top	330	362	136	105	67	M16
	B500MTJ3	20" 3-jaw Self Centering Master Jaw Scroll Chuck; Semi-Steel Body	500mm/20"	2pc Master/Top	420	458	200	120	77	M20
	B630MTJ3	25" 3-jaw Self Centering Master Jaw Scroll Chuck; Semi-Steel Body	630mm/25"	2pc Master/Top	545	586	275	135	85	M20
6 Jaw	B125MTJ6	5" 6-jaw Self Centering Master Jaw Scroll Chuck; Semi-Steel Body	125mm/5"	2pc Master/Top	95	108	33	56	40	M8
	B160MTJ6	6" 6-jaw Self Centering Master Jaw Scroll Chuck; Semi-Steel Body	160mm/6"	2pc Master/Top	125	140	42	65	40	M10
	B200MTJ6	8" 6-jaw Self Centering Master Jaw Scroll Chuck; Semi-Steel Body	200mm/8"	2pc Master/Top	160	176	55	75	44	M10
	B250MTJ6	10" 6-jaw Self Centering Master Jaw Scroll Chuck; Semi-Steel Body	250mm/10"	2pc Master/Top	200	224	76	85	54	M12
	B315MTJ6	12" 6-jaw Self Centering Master Jaw Scroll Chuck; Semi-Steel Body	315mm/12"	2pc Master/Top	260	286	103	94	57	M12
	B400MTJ6	15" 6-jaw Self Centering Master Jaw Scroll Chuck; Semi-Steel Body	400mm/15"	2pc Master/Top	330	362	136	105	67	M16
	B500MTJ6	20" 6-jaw Self Centering Master Jaw Scroll Chuck; Semi-Steel Body	500mm/20"	2pc Master/Top	420	458	200	120	77	M20
	B630MTJ6	25" 6-jaw Self Centering Master Jaw Scroll Chuck; Semi-Steel Body	630mm/25"	2pc Master/Top	545	586	275	135	85	M20

Work Holding

4 Jaws Independent Chucks - Type IC



FEATURES

BODY:

High strength cast iron alloyed with manganese and chrome (SC iron optional)

JAWS:

Case hardened and precision ground at gripping faces and jaw ways.

OPERATING SCREW:

- Case hardened alloy steel for strength and wear resistance.
- Square thread for HIGH GRIPPING FORCE

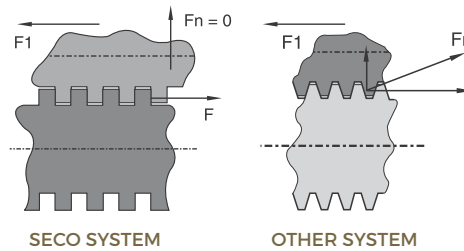
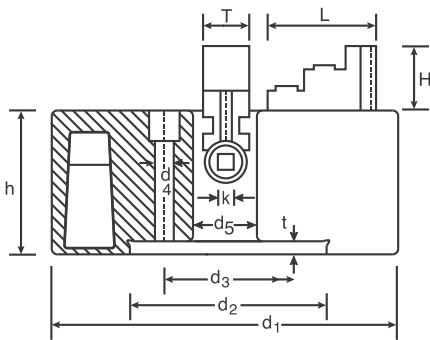

F : Force applied
 Fn : Force lost
 F1 : Gripping Force
 STATE SYSTEM F1=F
 Others System F1=F-Fn
 F1<20%F



THRUST BEARING:

Case hardened alloy steel so designed to provide maximum strength and life to working parts

DIMENSIONAL DATA (Heavy Duty)

Catalog Number	Nominal Size d1	d2	d3 H7	d4	d5	t	h	k	T	L	H	Max. Rec. rev/min	Clamping Capacity	Wt. in Kg.	
160IC	6.30	4.921	5.511	M-10x4	1.771	0.236	2.755	0.3149	0.944	2.165	0.866	750	0.236	5.905	10
200IC	7.992	3.740	3.251	M-10x4	1.968	0.236	3.267	0.3937	1.1417	2.952	1.220	750	0.472	7.874	17
250IC	10	4.921	4.125	M-10x4	2.362	0.315	3.267	0.3937	1.1417	3.346	1.338	600	0.708	10	20
305IC	12.204	6.299	5.251	M-12x4	2.952	0.393	3.700	0.4724	1.3385	3.937	1.732	600	0.708	12.204	34
350IC	13.897	6.299	5.251	M-12x4	3.149	0.393	3.700	0.4724	1.3385	4.330	1.732	600	0.708	13.897	40
400IC	15.748	7.874	6.748	M-16x4	3.937	0.472	3.937	0.2424	1.5748	4.724	2.559	600	1.0	15.748	60
450IC	17.716	7.874	6.748	M-16x4	3.937	0.472	3.937	0.551	1.5748	4.724	2.559	600	1.0	17.716	75
500IC	20.472	10.236	9.251	M-18x4	5.0	0.708	4.330	0.551	1.850	5.905	3.385	450	2.165	20.472	107
600IC	24.803	10.236	9.251	M-18x4	7.0	0.708	4.330	0.551	1.850	5.905	3.385	450	2.165	24.803	140
800IC	31.496	15.157	13.0	M-22x8	10.623	0.472	6.496	0.866	2.756	8.188	3.937	400	3.937	31.50	400
800IC	31.496	25.787	23.740	M-18x8	21.062	0.472	6.496	0.866	2.756	8.188	3.937	400	3.937	31.50	350

DIMENSIONAL DATA (Light Duty) (For Grinding Machines)

100ICL	3.937	3.504	2.952	M-8x4	1.0	0.157	1.338	0.196	0.413	1.456	0.630				
152ICL	6.0	3.248	2.756	M-8x4	1.574	0.196	1.811	0.275	0.669	2.165	0.787				
200ICL	8.0	3.740	3.248	M-10x4	1.811	0.196	2.007	0.275	0.748	2.519	0.944				
254ICL	10.0	5.0	4.370	M-10x4	1.968	0.196	2.716	0.275	1.0	3.267	1.181				

NOTE: All dimensions are in inches

Work Holding

OCDK - Open Center Direct Mount Power Chuck

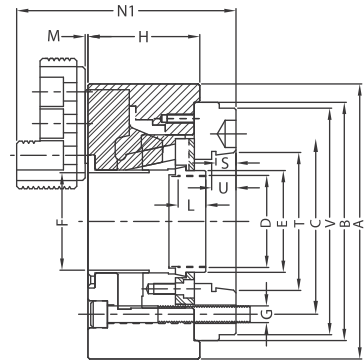
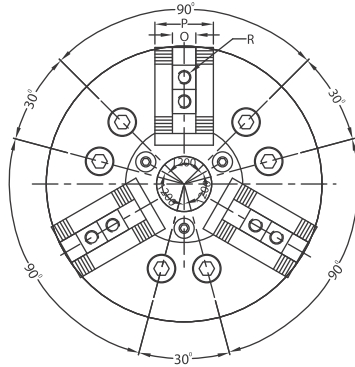

OCDK (Direct Mounting)

Accutek open center power chucks with thru hole are ideal for high speed chucking, bar chucking, and universal machining. These chucks come fitted with a back-plate ready to mount on the machine.

FEATURES

- High Speed applications
- Constant accuracy & high endurance
- Strong gripping force
- Kitagawa B-200 Series compatible

DIMENSIONAL DATA (Heavy Duty)

Catalog Number	A	B	Taper Nose	C	D	E	F	G	H	J		L	M	N	N1	OH7	P	Q	R	S	T	U	Serrations
										Min.	Max.												
135OCDK3	135 mm	110	A2-4	82.6	M36 x 2.0	48	33	3xM10	61	-2.30	8.20	20	1.5	92	105	10	27	4	M8 x 1.25	10	65.513	12	1.5mm x 60°
170OCDK3	170 mm	140	A2-5	104.8	M55 x 2.0	60	45	6xM10	81	-11.30	2.60	20	2	117	130	12	32	5	M10 x 1.25	12	82.563	15	1.5mm x 60°
210OCDK3	210 mm	170	A2-6	133.4	M60 x 2.0	66	52	6xM12	92	-11.70	2.25	20	2	144	163	14	37	5	M12 x 1.75	13	106.375	16	1.5mm x 60°
254OCDK3	254 mm	220	A2-8	171.4	M85 x 2.0	94	75	6xM16	100	-10.00	9.00	20	2	156	175	16	42	5	M12 x 1.75	14	139.719	18	1.5mm x 60°
305OCDK3	305 mm	220	A2-8	171.4	M100 x 2.0	108	90	6xM16	110	-3.00	20	35	2	161	185	21	52	6	M16 x 2.0	14	139.719	18	1.5mm x 60°
380OCDK3	380 mm	300	A2-11	235.0	M130 x 2.0	139	117.5	6xM20	131	-10.50	14.50	34	5	222.5	250	24	62	6	M20 x 2.5	16	196.869	20	1.5mm x 60°
450OCDK3	450 mm	380	A2-11	235.0	M130 x 2.0	139	117.5	6xM20	131	-10.50	14.50	34	5	222.5	250	24	62	6	M20 x 2.5	16	196.869	20	1.5mm x 60°
530OCDK3	530 mm	380	A2-15	330.20	M155 x 3.0	170	140	6xM22	140	-11.50	13.5	41	6	231.5	277	24	62	6	M20 x 2.5	17	285.78	21	1.5mm x 60°

EXTRA LARGE BORE

Catalog Number	A	B	Taper Nose	C	D	E	F	G	H	J		L	M	N	N1	OH7	P	Q	R	S	T	U	Serrations
										Min.	Max.												
170OCDKBB3	170 mm	140	A2-5	104.8	M60 x 2.0	65	52	6xM10	81	-11.50	1.00	20	2	117	130.0	12	32	5	M10 x 1.25	12	82.563	15	1.5mm x 60°
210OCDKBB3	210 mm	170	A2-6	133.4	M75 x 2.0	80	62	6xM12	91	-17.20	3.00	20	2	144	163.0	14	37	5	M12 x 1.75	13	106.375	16	1.5mm x 60°
254OCDKBB3	254 mm	220	A2-8	171.4	M98 x 2.0	123	90	6xM16	100	-10.50	11.00	20	2	156	175.0	16	42	5	M12 x 1.75	14	139.719	18	1.5mm x 60°
325OCDKBB3	325 mm	300	A2-11	235	M130 x 2	123	117	6xM18	112	-3	20	35	2	169	193.0	21	52	6	M16 x 2.00	16	196.869	20	1.5mm x 60°

NOTE: 1/16" X 90° serrations are optional.

SIZE	Max. RPM	Jaw Stroke (Per Jaw)	Plunger Stroke (Max.)	Weight (Kgs.) approx	Operating Force (Max. Kgf.)	Gripping Force (Max. Kgf.)
135 mm	6000	2.75	10	9	1600	3000
170 mm	6000	2.75	12	12	3000	7000
210 mm	5000	3.75	16	20	3000	7500
254 mm	4200	4.4	19	35	5000	10000
305 mm	3200	5.5	23	50	6000	13500
325 mm	3200	5.5	23	65	6000	13500
380 mm	2500	5.3	25	120	7200	18000
450 mm	2200	5.3	25	130	7200	18000
530 mm	2200	5.3	25	130	7200	18000

Chucks can be supplied with back plates of other International Standards on demand.

Work holding

T-Nuts/Jaw Nuts

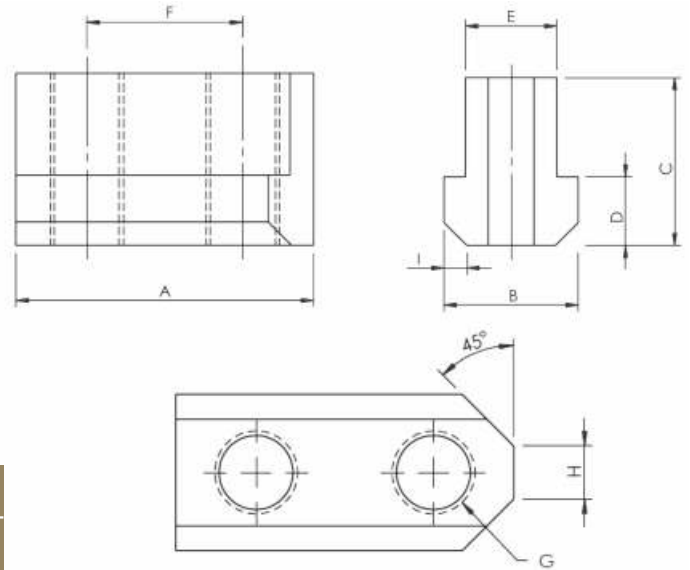
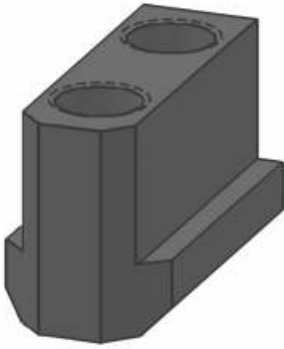

FEATURES

- Made with 4140 mild steel, heat treated to 28-40 HRC

Catalog Number	Suitable for	Chuck Size (mm/inch)	All Dimensions in Inches								
			A	B	C	D	E	F	G	H	I
TN6T1	Matsumoto	160mm/6"	1.4398	0.6898	0.8701	0.2953	0.4717	0.7874	M10	0.256	0.098 x 45°
TN8T1	Kitagawa B-208	200mm/8"	1.8299	0.8098	0.8098	0.3346	0.5508	0.9843	M12	0.472	0.112 x 45°
TN8T2	Kitagawa, Matsumoto, Howa (H07MA-8, H015-8)	200mm/8"	1.8701	0.8000	1.0000	0.3346	0.5508	0.9843	M12	0.295	0.112 x 45°
TN10T1	Kitagawa, Matsumoto, Howa H01MA-10	250mm/10"	2.0496	0.8665	1.0000	0.3346	0.6299	1.1811	M12	0.295	0.112 x 45°
TN10T2	Kitagawa B-210	250mm/10"	2.0098	0.8898	0.8500	0.3346	0.6299	1.1811	M12	0.433	0.112 x 45°
TN12T1	Kitagawa, Matsumoto, Howa	315mm/12"	2.2500	1.0394	1.2996	0.5299	0.7087	1.1811	M14	0.354	0.177 x 45°
TN12T2	Kitagawa B-212	315mm/12"	2.1898	1.1598	1.0925	0.4528	0.8268	1.1811	M16	0.512	0.177 x 45°
TN15T1	Kitagawa B-215	400mm/15"	3.1496	1.3197	1.7898	0.6500	0.9449	1.6929	M20	0.472	0.196 x 45°

Jaw Boring Rings

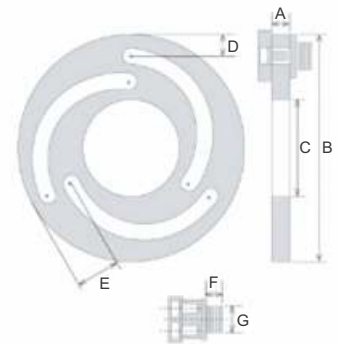

Catalog Number	Description	Chuck Diameter	C ID Inch	"B" OD Inch	F Pin Depth	G Pin Diameter
JBR05	5.0" Chuck Jaw Boring Ring	5.0"	2.362	5.511	0.354	0.511
JBR06	6.0" Chuck Jaw Boring Ring	6.0"	3.149	6.614	0.354	0.649
JBR08	8.0" Chuck Jaw Boring Ring	8.0"	4.527	8.582	0.354	0.728
JBR10	10.0" Chuck Jaw Boring Ring	10.0"	5.905	10.157	0.354	0.728
JBR12	12.0" Chuck Jaw Boring Ring	12.0"	7.401	12.440	0.354	0.885
JBR16	16.0" Chuck Jaw Boring Ring	16.0"	9.055	14.960	0.629	1.220

Work holding

Aluminum Pie Jaws - Serrated and Tongue & Groove

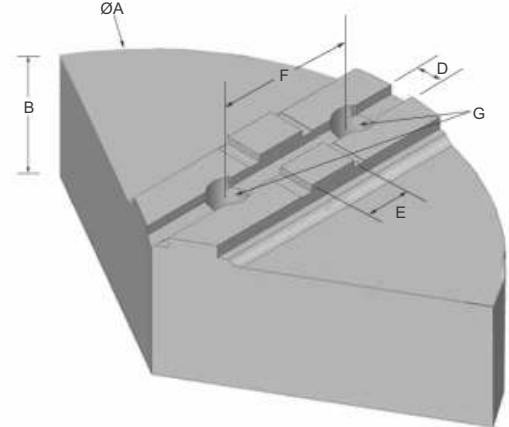
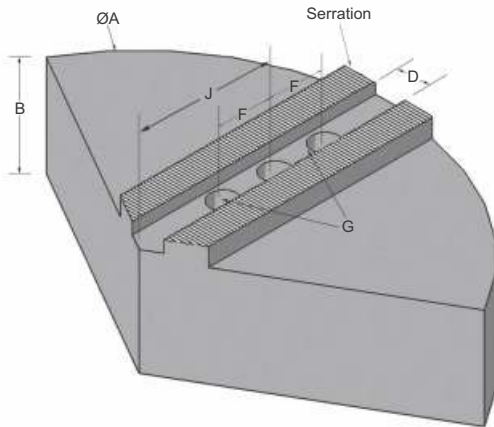

Catalog Number	A	B	D	E	F	G	J	Serrations
RAK620	6.0"	2.0"	0.472"	-	0.787"	M10	1.626"	1.5 x 60°
RAK640	6.0"	4.0"	0.472"	-	0.787"	M10	1.626"	1.5 x 60°
RAK820	8.0"	2.0"	0.551"	-	0.984"	M10	2.244"	1.5 x 60°
RAK840	8.0"	4.0"	0.551"	-	0.984"	M10	2.244"	1.5 x 60°
RAK1020	10.0"	2.0"	0.630"	-	1.181"	M12	2.374"	1.5 x 60°
RAK1040	10.0"	4.0"	0.630"	-	1.181"	M12	2.374"	1.5 x 60°
RAK1220	12.0"	2.0"	0.827"	-	1.181"	M12	2.874"	1.5 x 60°
RAK1240	12.0"	4.0"	0.827"	-	1.181"	M12	2.874"	1.5 x 60°

Catalog Number	A	B	D	E	F	G	J	Serrations
RAT620	6.0"	2.0"	0.313"	0.500"	1.500"	3/8" BSW	1.360"	-
RAT820	8.0"	2.0"	0.313"	0.500"	1.750"	3/8" BSW	2.150"	-
RAT840	8.0"	4.0"	0.313"	0.500"	1.750"	3/8" BSW	2.150"	-
RAT860	8.0"	6.0"	0.313"	0.500"	1.750"	3/8" BSW	2.150"	-
RAT1020	10.0"	2.0"	0.500"	0.750"	2.126"	1/2" UNC	2.230"	-
RAT1030	10.0"	3.0"	0.500"	0.750"	2.126"	1/2" UNC	2.230"	-
RAT1040	10.0"	4.0"	0.500"	0.750"	2.126"	1/2" UNC	2.230"	-
RAT1220	12.0"	2.0"	0.500"	0.750"	2.500"	1/2" UNC	3.370"	-
RAT1225	12.0"	2.5"	0.500"	0.750"	2.500"	1/2" UNC	3.370"	-
RAT1530	15.0"	3.0"	0.500"	0.750"	3.000"	5/8" BSW	3.785"	-

Work holding

Serrated Soft Steel Top Jaws with Flat or Pointed Ends

SERRATION:- 1.5 X 60°

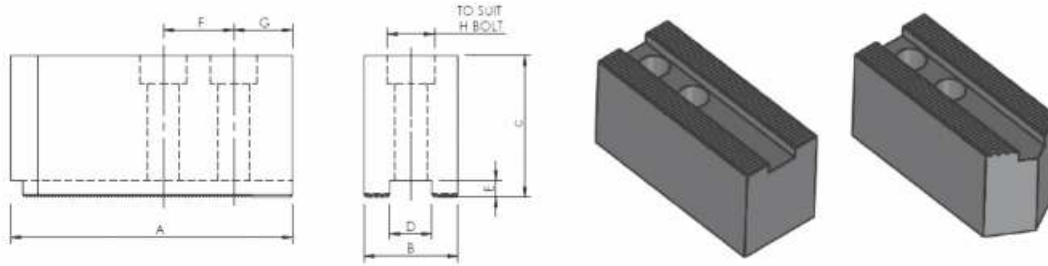

NOTE: ALL DIMENSIONS ARE IN INCHES

FLAT

POINTED

Chuck Size (Inch)	Suitable for Chuck Brands	Catalog Numbers				A	B	C	D	E	F	G	H	Wt. each (lbs)
		Steel		Aluminum										
		Pointed	Flat	Point	Flat									
4 & 5	Kitagawa (B-204 / B-205)	SP438T1				2.0	1.0	1.50	0.394 (10MM)	0.118	0.551 (14MM)	0.40	M8	0.7
5	Kitagawa (B-05)	SP538T1				2.5	1.0	1.50	0.394 (10MM)	0.157	0.709 (18MM)	0.50	M8	0.9
5	Strong (N-05 / NT-05)	SP538T2				2.5	1.0	1.50	0.394 (10MM)	0.157	0.748 (19MM)	0.50	M8	0.9
5	Kitagawa	SP575T3				2.5	1.0	3.0	0.394 (10MM)	0.197	0.551 (14MM)	0.433	M8	0.7
6	Matsumoto (Z-6, ZA-5-6-0, ZA-5-6B, ZJA5-6)	SP638T3				3.0	1.25	1.50	0.433 (11MM)	0.197	0.984 (25MM)	0.433	M8	1.3
6	Kitagawa (B206 / B06)	SP638T2	SF638T1	AP638T1	AF638T1	3.0	1.25	1.50	0.472 (12MM)	0.197	0.787 (20MM)	0.433	M10	1.3
6	Kitagawa (B206 / B06)	SP675T2	SF675T1	AP675T1	AF675T1	3.0	1.25	3.0	0.472 (12MM)	0.236	0.787 (20MM)	0.433	M10	2.9
8	Kitagawa, Sam Chully, SMW, Strong, Matsumoto, Howa	SP850T3	SF850T1	AP850T1	AF850T1	4.0	1.50	2.0	0.551 (14MM)	0.197	0.984 (25MM)	1.0	M12	3.1
8	Kitagawa, Sam Chully, SMW, Strong, Matsumoto, Howa	SP8100T2	SF8100T1	AP8100T1	AF8100T1	4.0	1.50	4.0	0.551 (14MM)	0.256	0.984 (25MM)	1.0	M12	3.1
10	Kitagawa, Sam Chully, SMW, Strong, Matsumoto, Howa	SP1050T2	SF1050T1	AP1050T1	AF1050T1	4.5	1.50	2.0	0.63 (16MM)	0.197	1.181 (30MM)	1.0	M12	5.7
10	Kitagawa, Sam Chully, SMW, Strong, Matsumoto, Howa	SP10100T2	SF10100T1	AP10100T1	AF10100T1	4.5	1.50	4.0	0.63 (16MM)	0.197	1.181 (30MM)	1.0	M12	3.5
12	Kitagawa (B-12, Sam Chully, Strong, Matsumoto, Howa)	SP1250T3	N/A	N/A	N/A	5.5	2.0	2.0	0.709 (18MM)	0.197	1.181 (30MM)	1.0	M14	6.6
12	Kitagawa (B-12, Sam Chully, Strong, Matsumoto, Howa)	SP12100T2	SF12100T1	AP12100T1	AF12100T1	5.5	2.0	4.0	0.709 (18MM)	0.197	1.181 (30MM)	1.0	M14	3.5
12	Kitagawa B-212, SMW, Sam Chully, Matsumoto, Howa	SP1250T5	SF1250T2	AP1250T2	AF1250T2	5.5	2.0	2.0	0.827 (21MM)	0.197	1.181 (30MM)	1.0	M16	12
12	Kitagawa B-212, SMW, Sam Chully, Matsumoto, Howa	SP12100T5	SF12100T2	AP12100T2	AF12100T2	5.5	2.0	4.0	0.827 (21MM)	0.197	1.181 (30MM)	1.0	M16	12

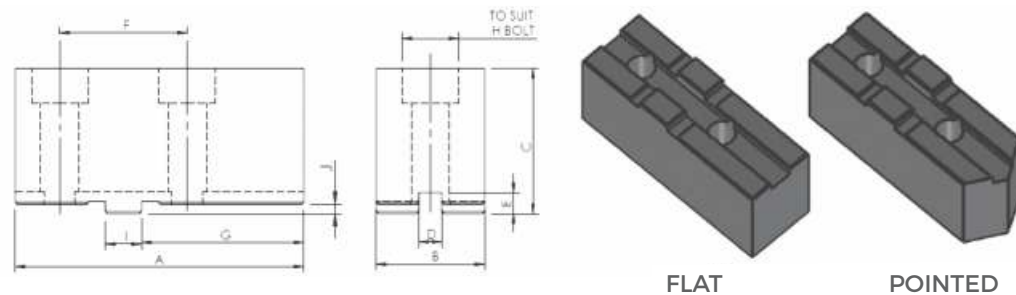

FLAT

POINTED

Chuck Size (Inch)	Suitable for Chuck Brands	Catalog Numbers				A	B	C	D	E	F	G	H	Wt. each (lbs)
		Steel		Aluminum										
		Pointed	Flat	Point	Flat									
6	Bergman, Buck, Bison, Chusman, Huron, Rohm, Forkardt, Pratt Burnerd America, Nobel, Yuasa	SPT638T2	SFT638T1	APT638T2	AFT638T1	3.0	1.25	1.5	0.313 (7.95 MM)	0.291	1.5 (38.10 MM)	1.50	3/8"	0.50
8		SPT850T2	SFT850T1	APT850T2	AFT850T1	4.0	1.5	2.0	0.313 (7.95 MM)	0.291	1.77 (44.958 MM)	2.25	3/8"	0.50
10		SPT1050T2	SFT1050T1	APT1050T2	AFT1050T1	5.0	1.5	2.0	0.5 (12.70 MM)	0.291	2.125 (53.975 MM)	2.25	M12	0.75
10		SPT10100T2	SFT10100T1	APT10100T2	AFT10100T1	5.0	1.5	4.0	0.5 (12.70 MM)	0.291	2.125 (53.975 MM)	2.25	M12	0.75
12		N/A	SFT1250T1	N/A	AFT1250T1	6.0	2.0	2.0	0.5 (12.70 MM)	0.291	2.125 (53.975 MM)	3.13	M12	0.75
12		SPT1250T2	N/A	APT1250T2	N/A	6.0	2.0	2.0	0.5 (12.70 MM)	0.291	2.5 (63.50 MM)	3.13	M12	0.75
12		N/A	SFT12100T1	N/A	AFT12100T1	6.0	2.0	4.0	0.5 (12.70 MM)	0.291	2.5 (63.50 MM)	3.13	M12	0.75

BMT-40 Inch & Metric Tool Holders

DURATURN 2050, 2550 (MC)	NRX 2000
NL, NLX 1500, 2000, 2500 20 STATIONS TURRET	NZ 1500, 2000 16 STATIONS TURRETS
NT, NTX 1000, 2000	NZX 1500, 2000 20 STATIONS TURRETS
NT 3000/3100/3150/3200	



STATIC TOOL HOLDERS

Inch/Metric	Item Name	Item ID	3D-View of Tool that be used in Our Tool Holders	Tool Clamping	Coolant Supply Type	Applications	3D View
I	B40 ATH 12-25.4 L115	SD58014		□1.0"	External Coolant Supply	180° Reversible & Used for Facing & Face Grooving	
M	B40 ATH 12-25 L115	SD48065		□25mm			
I	B40 ATH 12-19.05 L115	SD58013		□0.75"			
M	B40 ATH 12-20 L115	SD48447		□20mm			
I	B40 BTH 12-31.75 CH100 L115	SD48426		Ø1.25"	Internal & External Coolant Supply	180° Reversible & Used for 'U' Drilling, Boring, Drilling, Internal Threading, ID Grooving	
M	B40 BTH 12-32 CH100 L115	SD48153		Ø32mm			
I	B40 BTH 12-38.1 CH100 L115	SD48670		Ø1.5"			
M	B40 BTH 12-40 CH100 L115	SD58258		Ø40mm			
I	B40 BTH 12-38.1 CH100 L140	SD58015		Ø1.5"			
M	B40 BTH 12-40 CH100 L140	SD48141		Ø40mm			
I	B40 BTHD 12-25.4 CH75/105 L130	SD48522		Ø1.0"			
M	B40 BTHD 12-25 CH75/105 L130	SD48068		Ø25mm			
I	B40 BTHS 12-31.75 CH90 L115	SD58166		Ø1.25"	External Coolant Supply	180° Reversible & Used for Boring, Drilling, Internal Threading, ID Grooving (Gives Better Clamping & Rigidity)	
M	B40 BTHS 12-32 CH90 L115	SD48837		Ø32mm			
I	B40 BTHS 12-38.1 CH90 L115	SD48667		Ø1.5"			
M	B40 BTHS 12-40 CH90 L115	SD48838		Ø40mm			
I	B40 BTHD 12-25.4 CH75 L130	SD58016		Ø1.0"	Internal & External Coolant Supply	180° Reversible & Used for 'U' Drilling, Boring, Drilling, Internal Threading, ID Grooving	
M	B40 BTHD 12-25 CH75 L130	SD48139		Ø25mm			
I	B40 RTH 12-19.05 L115	SD58019		□0.75"	External Coolant Supply	180° Reversible & Used for OD Turning, OD Threading, Parting & OD Grooving	
M	B40 RTH 12-20 L115	SD48138		□20mm			
I	B40 RTH 12-19.05 L115-LEFT	SD58020		□0.75"			
M	B40 RTH 12-20 L115-LEFT	SD48209		□20mm			

BMT-40 Inch & Metric Tool Holders

DURATURN 2050, 2550 (MC)	NRX 2000
NL, NLX 1500, 2000, 2500 20 STATIONS TURRETS	NZ 1500, 2000 16 STATIONS TURRETS
NT, NTX 1000, 2000	NZX 1500, 2000 20 STATIONS TURRETS
NT 3000/3100/3150/3200	



STATIC TOOL HOLDERS

Inch/Metric	Item Name	Item ID	3D-View of Tool that be used in Our Tool Holders	Tool Clamping	Coolant Supply Type	Applications	3D View
I	B40 RTH 12-19.05 L115-RIGHT	SD58021		□0.75"	External Coolant Supply	180° Reversible & Used for OD Turning, OD Threading, Parting & OD Grooving	
M	B40 RTH 12-20 L115-RIGHT	SD48210		□20mm			
I	B40 RTH 12-25.4 L120	SD58022		□1.0"			
M	B40 RTH 12-25 L120	SD48204		□25mm			
I	B40 RTH 12-25.4 L124	SD58023		□1.0"			
M	B40 RTH 12-25 L124	SD48154		□25mm			
I	B40 RTH 12-25.4 L141	SD58024		□1.0"			
M	B40 RTH 12-25 L141	SD48062		□25mm			
I	B40 RTHD 12-19.05 L140	SD58025		□0.75"			
M	B40 RTHD 12-20 L140	SD48063		□20mm			
I	B40 RTHM 12-19.05 L130	SD58026		□0.75"			
M	B40 RTHM 12-20 L130	SD48064		□20mm			
I	B40 RTHM 12-25.4 L150	SD58027		□1.0"			
M	B40 RTHM 12-25 L150	SD48144		□25mm			

DRIVEN TOOL HOLDERS

Inch/Metric	Item Name	Item ID	3D-View of Tool that be used in Our Tool Holders	Tool Clamping	Coolant Supply Type	Applications	3D View
ER32	B40 ATH ER32 DIN 1809 EXT NUT	SD7504		ER32	External Coolant Supply	Used for Straight (0°) OD Drilling & OD Slotting & Milling	
ER32	B40 RTH ER32 CH-85 DIN 1809 EXT INT NUT	SD7506		ER32	External Coolant Supply	180° Reversible & used for Right Angle (90°) Face Drilling & Milling	

BMT-60 Inch & Metric Tool Holders



NL, NLX 1500, 2000, 2500, 3000 12 STATIONS TURRETS	NZL 2000, 2500
NLX 4000 12 STATIONS TURRETS	NZX 2500 12 STATIONS TURRETS
NT 4000, 4200, 4250, 4300, 5000, 5400	



STATIC TOOL HOLDERS

Inch/Metric	Item Name	Item ID	3D-View of Tool that be used in Our Tool Holders	Tool Clamping	Coolant Supply Type	Applications	3D View	
I	B60 BTH 20-38.1 CH80 L135	SD48246		Ø1.50"	Internal & External Coolant Supply	Used for 'U' Drilling, Boring, Drilling, Internal Threading, ID Grooving		
M	B60 BTH 20-40 CH80 L135	T10097A		Ø40mm				
I	B60 BTH 20-50.8 CH80 L135	SD48247		Ø2.0"				
M	B60 BTH 20-50 CH80 L135	SD48516		Ø50mm				
I	B60 BTH 20-63.5 CH80 L140	SD48194		Ø2.50"	External Coolant Supply			
M	B60 BTH 20-60 CH80 L140	SD58391		Ø60mm				
I	B60 BTHS 20-63.5 CH80 L140	SD58204			Ø2.50"		External Coolant Supply	
M	B60 BTHS 20-60 CH80 L140	SD58392			Ø60mm			
I	B60 BTHD 20-31.75 CH80/125 L135	SD48178			Ø1.25"		Internal & External Coolant Supply	
M	B60 BTHD 20-32 CH80/125 L135	T10096A			Ø32mm			
I	B60 ATH 20-25.4 L130	SD48666		□1.0"	External Coolant Supply	Used for Facing & Face Grooving		
M	B60 ATH 20-25 L130	T03005A		□25mm				
I	B60 RTH 20-25.4 L130 H70	SD58028			□1.0"	External Coolant Supply	180° Reversible & used for OD Turning, OD Threading, Parting & OD Grooving	
M	B60 RTH 20-25 L130 H70	T00186A			□25mm			
I	B60 RTH 20-25.4 L130 H90	SD58029			□1.0"			
M	B60 RTH 20-25 L130 H90	T00385A			□25mm			
I	B60 RTH 20-25.4 L130 H110	SD58030			□1.0"			
M	B60 RTH 20-25 L130 H110	T00197A			□25mm			
I	B60 RTH 20-25.4 L163.5	SD58031			□1.0"			
M	B60 RTH 20-25 L163.5	SD48060			□25mm			
I	B60 RTHD 20-25.4 L165.5	SD48059			□1.0"	External Coolant Supply		
M	B60 RTHD 20-25 L165.5	SD48059			□25mm			

BMT-60 Inch & Metric Tool Holders



NL, NLX 1500, 2000, 2500, 3000 12 STATIONS TURRETS	NZL 2000, 2500
NLX 4000 12 STATIONS TURRETS	NZX 2500 12 STATIONS TURRETS
NT 4000, 4200, 4250, 4300, 5000, 5400	



STATIC TOOL HOLDERS

Inch/Metric	Item Name	Item ID	3D-View of Tool that be used in Our Tool Holders	Tool Clamping	Coolant Supply Type	Applications	3D View
I	B60 RTHM 20-25.4 L155.5	SD48428		□1.0"	External Coolant Supply	Used for OD Turning, OD Threading & OD Grooving in Multiple (M3 & M4) Applications for Main & Sub Spindle	
M	B60 RTHM 20-25 L155.5	T00184A		□25mm			
I	B60 RTHM 20-25.4 L189	SD58032		□1.0"			
M	B60 RTHM 20-25 L189	SD48061		□25mm			

DRIVEN TOOL HOLDERS

Inch/Metric	Item Name	Item ID	3D-View of Tool that be used in Our Tool Holders	Tool Clamping	Coolant Supply Type	Applications	3D View
ER32	B60 ATH ER32 DIN 1809 EXT NUT	SD7602		ER32	External Coolant Supply	Used for Straight (0°) OD Drilling & OD Slotting & Milling	
ER40	B60 ATH ER40 DIN 1809 EXT NUT	SD7609		ER40			
ER32	B60 RTH ER32 CH90 DIN 1809 EXT NUT (6000 RPM)	SD7605		ER32		180° Reversible & used for Right Angle (90°) Face Drilling & Milling	
ER40	B60 RTH ER40 CH90 DIN 1809 EXT NUT (10000 RPM)	SD7611		ER40			
ER40	B60 RTH ER40 CH90 DIN 1809 EXT NUT (6000 RPM)	SD7606		ER40			

BMT-68 Metric & Inch Tool Holders

QTC/QTU 100-350 M/MY/MS/MSY	QT/QTS 100M/MY/MS/MSY	MZ 68 B/C
QT 200, 250 M/MY/MS/MSY/16D	QT/QTS 200, 250 M/MY/MS/MSY	QT-Ez 8-12 M/MY/MSY



STATIC TOOL HOLDERS

Inch/Metric	Item Name	Item ID	3D-View of Tool that be used in Our Tool Holders	Tool Clamping	Coolant Supply Type	Applications	3D View
M	B68 ATH 16-25 L140	SD48170		□25mm	External Coolant Supply	Used for Facing & Face Grooving	
I	B68 ATH 16-25.4 L140	SD48633		□1.0"			
M	B68 BTH 16-25 CH95 L140	SD48520		∅25mm	Internal & External Coolant Supply	Used for 'U' Drilling, Boring, Drilling, Internal Threading, ID Grooving	
I	B68 BTH 16-25.4 CH95 L140	SD48634		∅1.0"			
M	B68 BTH 16-32 CH95 L140	SD58172		∅32mm			
I	B68 BTH 16-31.75 CH95 L140	SD58171		∅1.25"			
M	B68 BTH 16-40 CH95 L140	SD48169		∅40mm			
I	B68 BTH 16-38.1 CH95 L140	SD48248	∅1.50"				
M	B68 RTH 16-20 L143	SD58085		□20mm	External Coolant Supply	Used for OD Turning, OD Threading, Parting & OD Grooving	
I	B68 RTH 16-19.05 L143	SD58170		□0.75"			
M	B68 RTH 16-25 L143	SD48074		□25mm			
I	B68 RTH 16-25.4 L143	SD48632		□1.0"			
M	B68 ATH 16-25 L144	SD48067		□25mm			
I	B68 ATH 16-25.4 L144	SD48631	□1.0"		Used for OD Turning, OD Threading & OD Grooving in Multiple (M3 & M4) Applications for Main & Sub Spindle		

DRIVEN TOOL HOLDERS

Inch/Metric	Item Name	Item ID	3D-View of Tool that be used in Our Tool Holders	Tool Clamping	Coolant Supply Type	Applications	3D View
ER32	B68 ATH ER32 DIN 1809 EXT NUT	SD8101		ER32	External Coolant Supply	Used for Straight (0°) OD Drilling & OD Slotting & Milling	
ER32	B68 RTH ER32 CH-80 DIN 1809 EXT. NUT	SD8102		ER32	External Coolant Supply	Used for Right Angle (90°) Face Drilling & Milling	



HAAS BOT Metric & Inch Tool Holders

SPHOORTI
Smarter Assets



HAAS: ST-10/15 (12 Station Hybrid Turret), ST-10/15 (BOT-Turret)-BOLT PATTERN (45 x 70)



Inch/Metric	Item Name	Item ID	3D-View of Tool that be used in Our Tool Holders	Tool Clamping	Coolant Supply Type	Applications	3D View
I	CBTH 15-19.05 CH25.4 L77.2 TC	SD56011		Ø0.75"	Internal & External Coolant Supply	Used for 'U' Drilling, Boring, Drilling, Internal Threading, ID Grooving	
M	CBTH 15-20 CH25.4 L77.2 TC	SD56021		Ø20mm			
I	CBTH 15-25.4 CH25.4 L77.2 TC	SD56019		Ø1.0"			
M	CBTH 15-25 CH25.4 L77.2 TC	SD56022		Ø25mm			
I	CBTH 15-31.75 CH25.4 L77.2 TC	SD56020		Ø1.25"			
M	CBTH 15-32 CH25.4 L77.2 TC	SD56023		Ø32mm			
I	CATH 15-19.05 L77.2	SD56025		□0.75"	External Coolant Supply	Used for Facing & Face Grooving	
M	CATH 15-20 L77.2	SD56024		□20mm			

HAAS: SL/ST-40 (BOT-Turret)-BOLT PATTERN (70 x 105)



Inch/Metric	Item Name	Item ID	3D-View of Tool that be used in Our Tool Holders	Tool Clamping	Coolant Supply Type	Applications	3D View
I	CBTH 20-50.8 CH41.275 L123.825	SD56005		Ø2.0"	Internal & External Coolant Supply	Used for 'U' Drilling, Boring, Drilling, Internal Threading, ID Grooving	
M	CBTH 20-50 CH41.275 L123.825	SD56007		Ø50mm			
I	CBTH 20-63.5 CH41.275 L123.825	SD56006		Ø2.50"			
M	CBTH 20-60 CH41.275 L123.825	SD56008		Ø60mm			
I	CATH 20-31.75 L123.825	SD56009		□1.25"	External Coolant Supply	Used for Facing & Face Grooving	
M	CATH 20-32 L123.825	SD56010		□32mm			

HAAS BOT Metric & Inch Tool Holders

BOLT PATTERN (45 x 80)

SPHOORTI
America's Assistant



HAAS: DS-30 (12 Station Hybrid Turret), SL-20/30, TL-15/25 (BOT-Turret), SL-20/30, TL-15/25 (12 Station Hybrid Turret), ST-20/25/30/35 (BOT Turret), ST-20/25/30/35 (12 Station Hybrid Turret)

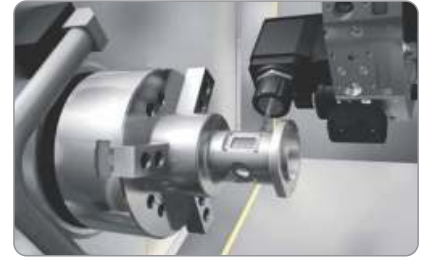

Inch/Metric	Item Name	Item ID	3D-View of Tool that be used in Our Tool Holders	Tool Clamping	Coolant Supply Type	Applications	3D View		
I	CBTH 20-25.4 CH31.75 L82.55 TC	30-1912		Ø1"	Internal & External Coolant Supply	Used for 'U' Drilling, Boring, Drilling, Internal Threading, ID Grooving			
M	CBTH 20-25 CH31.75 L82.55 TC	SD54071		Ø25					
I	CBTH 20-31.75 CH31.75 L82.55 TC	SD54068		Ø1.25"					
M	CBTH 20-32 CH31.75 L82.55 TC	30-2468		Ø32mm					
I	CBTH 20-38.1 CH31.75 L82.55 TC	20-0442A		Ø1.50"					
M	CBTH 20-40 CH31.75 L82.55 TC	30-3215		Ø40mm					
I	CBTH 20-50.8 CH31.75 L82.55 TC	SD56583		Ø2.0"					
M	CBTH 20-50 CH31.75 L82.55 TC	SD58400		Ø50mm					
I	CATH 20-25.4 L82.55	30-1911		□1.0"	External Coolant Supply	Used for Facing & Face Grooving			
M	CATH 20-25 L82.55	SD53870		□25mm					
I	CRTH 20-25.4 H55	SD54183		□1.0"		Used for ID Turning, OD Threading, Parting & OD Grooving			
M	CRTH 20-25 H55	SD54184		□25mm					
I	CRTH 20-25.4 H83	SD54181		□1.0"					
M	CRTH 20-25 H83	SD54182		□25mm					
I	CRTH 20-25.4 L103	SD54192		□1.0"					
M	CRTH 20-25 L103	SD54191		□25mm					
I	CRTHM 20-25.4 H55	SD54177		□1.0"					
M	CRTHM 20-25 H55	SD54178		□25mm					
I	CRTHM 20-25.4 H83	SD54179		□1.0"					
M	CRTHM 20-25 H83	SD54180		□25mm					
I	CBTH 20-19.05/19.05 CH76.2/114.3 L120.65 TC	SD54175		Ø0.75"			Internal & External Coolant Supply	Used for 'U' Drilling, Boring, Drilling, Internal Threading, ID Grooving	
M	CBTH 20-20/20 CH76.2/114.3 L120.65 TC	SD54176		Ø20mm					
I	CBTH 20-25.4/25.4 CH76.2/114.3 L120.65 TC	SD56343		Ø1.0"					
M	CBTH 20-25/25 CH76.2/114.3 L120.65 TC	SD56637		Ø25mm					
I	WEDGE 25.4 x 48.26	SD20-0668		□1.0"					
M	WEDGE 25 x 48.26	SD54208		□25mm					
I	COOLANT BALL Ø12.57 x 26.4	SD54209							
M	COOLANT BALL Ø12.57 x 20.7 (DUMMY)	SD54210							
I	COOLANT BALL Ø12.57 x 10.2	SD54211							

HAAS BMT-65 Inch & Metric Tool Holders

This includes all varieties of tool holder for both 12-Station HAAS BMT-TURRET. As we know BMT65 turret offers a half-station indexing option that increases your available tool stations to 24, with 12 of those stations able to accept driven tools. The TURRET looks the same on the outside, but will index every 15 degrees, rather than every 30 degrees. Special static toolholders are included with this option.

MACHINE MAKE : HAAS

MACHINE MODEL : ST-20Y, ST-25Y, ST-30Y, ST-35Y, DS-30Y

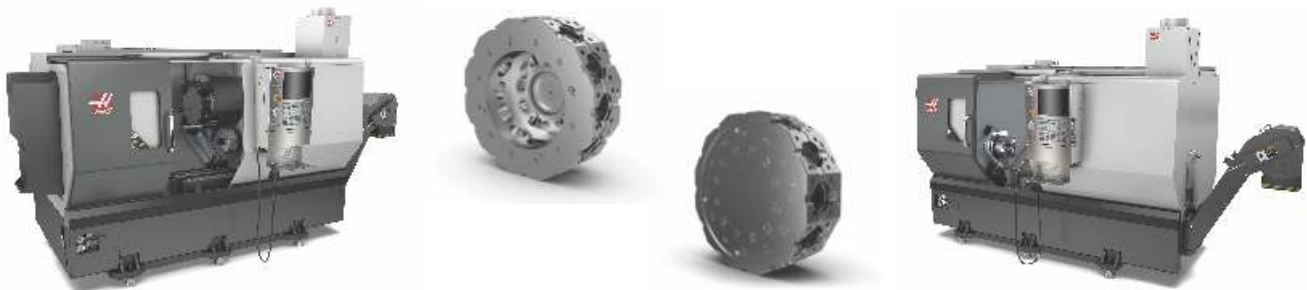

STATIC TOOL HOLDERS

Inch/ Metric	Item Name	Item ID	3D-View of Tool that be used in Our Tool Holders	Tool Clamping	Coolant Supply Type	Applications	3D View				
I	B65 ATH 18-25.4 L105	SD48526		□1.0"	External Coolant Supply	180° Reversible & used for facing & face grooving.					
M	B65 ATH 18-25 L105	SD48467		□25mm							
I	B65 BTH 18-38.1 CH72 L120	SD48527		Ø1.50"	Internal & External Coolant Supply	180° Reversible & used for "U" Drilling, Boring, Drilling, Internal Threading, ID Grooving					
M	B65 BTH 18-40 CH72 L120	SD48458		Ø40mm							
I	B65 BTH 18-25.4 CH72 L120	SD48528		Ø1.0"							
M	B65 BTH 18-25 CH72 L120	SD48466		Ø25mm							
I	B65 BTH 18-31.75 CH72 L120	SD48290		Ø1.25"							
M	B65 BTH 18-32 CH72 L120	SD48465		Ø32mm							
I	B65 BTH 18-38.1 CH72 L120	SD48529		Ø1.50"							
M	B65 BTH 18-40 CH72 L120	SD48468		Ø40mm							
I	B65 BTHS 18-25.4 CH72 L120	SD48564		Ø1.0"				External Coolant Supply	180° Reversible & Used for Boring, Drilling, Internal Threading, ID Grooving (Gives Better Clamping & Rigidity)		
M	B65 BTHS 18-25 CH72 L120	SD48563		Ø25mm							
I	B65 BTHS 18-38.1 CH72 L120	SD48565	Ø1.50"								
M	B65 BTHS 18-40 CH72 L120	SD48566	Ø40mm								
I	B65 BTHS 18-50.8 CH72 L120	SD48568	Ø2.0"								
M	B65 BTHS 18-50 CH72 L120	SD48567	Ø50mm								
I	B65 BTHS 18-25.4 CH72 L120 (SLIT & TC)	SD48574		Ø1.0"	Internal & External Coolant Supply	180° Reversible & used for Boring, Drilling, Internal Threading, ID Grooving (Gives Better Clamping & Rigidity)					
M	B65 BTHS 18-25 CH72 L120 (SLIT & TC)	SD48573		Ø25mm							
I	B65 BTHS 18-38.1 CH72 L120 (SLIT & TC)	SD48575		Ø1.25"							
M	B65 BTHS 18-40 CH72 L120 (SLIT & TC)	SD48576		Ø32mm							
I	B65 BTHS 18-50.8 CH72 L120 (SLIT & TC)	SD48578		Ø1.50"							
M	B65 BTHS 18-50 CH72 L120 (SLIT & TC)	SD48577		Ø40mm							
I	B65 RTH 18-25.4 L131	SD48530						□1.0"	External Coolant Supply	180° Reversible & used for "U" Drilling Boring, Drilling, Internal Threading, ID Grooving (Gives Better Clamping & Rigidity)	
M	B65 RTH 18-25 L131	SD48457						□25mm			
I/M	B65 RTHD 18-25/25.4 L131	SD58240		□25mm/ □1.0"	External Coolant Supply	180° Reversible & used for OD Turning, OD Threading, Parting & OD Grooving with Double Turning Tool Application.					

HAAS BMT-65 Inch & Metric Tool Holders

SPHOORTI
America's Assistant



This includes all varieties of tool holder for both 12-Station HAAS BMT-TURRET. As we know BMT65 turret offers a half-station indexing option that increases your available tool stations to 24, with 12 of those stations able to accept driven tools. The TURRET looks the same on the outside, but will index every 15 degrees, rather than every 30 degrees. Special static toolholders are included with this option.

MACHINE MAKE : HAAS

MACHINE MODEL : ST-20Y, ST-25Y, ST-30Y, ST-35Y, DS-30Y



STATIC TOOL HOLDERS

Inch/ Metric	Item Name	Item ID	3D-View of Tool that be used in Our Tool Holders	Tool Clamping	Coolant Supply Type	Applications	3D View
I	B65 BTH 18-25.4 CH72L154	SD48682		Ø1.0"	External Coolant Supply	180° Reversible & used for Boring, Drilling, Internal Threading, ID Grooving.	
M	B65 BTH 18-25 CH72 L154	SD48681		Ø25mm			
I	B65 BTH 18-31.75 CH72 L154	SD48531		Ø1.25"			
M	B65 BTH 18-32 CH72 L154	SD48449		Ø32mm			
I	B65 BTH 18-38.1 CH72 L154	SD48684		Ø1.50"			
M	B65 BTH 18-40 CH72 L154	SD48683		Ø40mm			
I	B65 BTH 18-25.4 CH72 L127	SD48680		Ø1.0"	Internal & External Coolant Supply	180° Reversible & used for "U" Drilling Boring, Drilling, Internal Threading, ID Grooving (Gives Better Clamping & Rigidity)	
M	B65 BTH 18-25 CH72 L127	SD48494		Ø25mm			
I	B65 BTH 18-31.75 CH72 L127	SD48532		Ø1.25"			
M	B65 BTH 18-32 CH72 L127	SD48452		Ø32mm			
I	B65 BTHS 18-38.1 CH72 L127	SD48227		Ø1.50"			
M	B65 BTHS 18-40 CH72 L127	SD48025		Ø40mm			
I	B65 RTHM 18-25.4 L164	SD48533		□1.0"	External Coolant Supply	Used for OD Turning, OD Threading & OD Grooving in Multiple (M3 & M4) Applications for Main & Sub Spindle	
M	B65 RTHM 18-25 L164	SD48455		□25mm			
I	B65 RTHM 18-25.4 L149	SD48534		□1.0"			
M	B65 RTHM 18-25 L149	SD48460		□25mm			
I	B65 BTHT 18-25.4 CH107/96.755/56 L154	SD48535		Ø1.0"	External Coolant Supply	Used in 24 Station BMT Tool Disc (A/F 387.35) Having 15 Degree Indexing Option	
M	B65 BTHT 18-25 CH107/96.755/56 L154	SD48462		Ø25mm			
I	B65 BTHT 18-25.4 CH107/96.755/56 L127	SD48536		Ø1.0"	Internal & External Coolant Supply		
M	B65 BTHT 18-25 CH107/96.755/56 L127	SD48464		Ø25mm			
I	B65 PTH-32 L126.5	SD48459		SH32	Internal & External Coolant Supply	180° Reversible & used Parting with Blade.	
I	B65 RTHA 18-25.4/19.05 L132	SD48579		□25.4mm/ □0.75"	External Coolant Supply	Used in 24 Station BMT Tool Disc (A/F 387.35) Having 15 Degree Indexing Option	
M	B65 RTHA 18-25/20 L132	SD48569		□25mm/ □20mm			
I	B65 RTHA 18-25.4 L132	SD48537		□1.0"			
M	B65 RTHA 18-25 L132	SD48463		□25mm			
I	B65 RTHMA 18-25.4/19.05 L162	SD48580		□25.4mm/ □0.75"			
M	B65 RTHMA 18-25/20 L162	SD48571		□25/□20mm			
I	B65 RTHMA 18-25.4 L162	SD48538		□1.0"			
M	B65 RTHMA 18-25 L162	SD48461		□25mm			

HAAS BMT-65 Inch & Metric Tool Holders

This includes all varieties of tool holder for both 12-Station HAAS BMT-TURRET. As we know BMT65 turret offers a half-station indexing option that increases your available tool stations to 24, with 12 of those stations able to accept driven tools. The TURRET looks the same on the outside, but will index every 15 degrees, rather than every 30 degrees. Special static toolholders are included with this option.

MACHINE MAKE : HAAS

MACHINE MODEL : ST-20Y, ST-25Y, ST-30Y, ST-35Y, DS-30Y



DRIVEN TOOL HOLDERS

Inch/Metric	Item Name	Item ID	3D-View of Tool that be used in Our Tool Holders	Tool Clamping	Coolant Supply Type	Applications	3D View
ER32	B65 ATH ER32 DIN1809 INT. NUT	SD7204		ER32	External Coolant Supply	Used for Straight (0°) OD Drilling & OD Slotting & Milling	
ER32	B65 ATH ER32 DIN1809 EXT. NUT	SD7223		ER32			
ER32	B65 RTH ER32 CH72 DIN1809 INT. NUT	SD7217		ER32			
ER32	B65 RTH ER32 CH72 DIN1809 EXT. NUT	SD7220		ER32			



THE HAAS BMT65
BASE MOUNT TOOLING TURRET

- STANDARD TURRET
12 LIVE-TOOL STATIONS
- OPTIONAL TURRET
12 DRIVEN STATIONS AND HALF-STATION INDEXING

THE HAAS BMT65
BASE MOUNT TOOLING TURRET

- STANDARD TURRET
12 LIVE-TOOL STATIONS
- OPTIONAL TURRET
12 DRIVEN STATIONS AND HALF-STATION INDEXING

THE HAAS BMT65
BASE MOUNT TOOLING TURRET

- IMPROVED CUTTING PERFORMANCE
- INCREASED TOOL LIFE
- EXTRA CLEARANCE
+5" ON AN ST-20Y

THE HAAS BMT65
BASE MOUNT TOOLING TURRET

- STANDARD TURRET
12 LIVE-TOOL STATIONS

The BMT65 turret offers a half-station indexing option that increases your available tool stations to 24, with 12 of those stations able to accept driven tools. The turret looks the same on the outside, but will index every 15 degrees, rather than every 30 degrees. Special static toolholders are included with this option.

BMT-45 & BMT-55 Tool Holders



HARDINGE TALENT (BMT45-GS 42, 51 SUPER-PRECISION, TALENT 42, 51)
& (BMT55-CONQUEST H51, SUPER PRECISION T56, T-65)



STATIC TOOL HOLDERS

SL. NO.	Item Name	Item ID	3D-View of Tool that be used in Our Tool Holders	Tool Clamping	Coolant Supply Type	3D View	BMT-TYPE
01	B45 ATH 15-20 L87	SD48079		□20mm	External Coolant Supply		BMT-45
02	B45 ATH 15-20 L103	SD48235		□20mm			BMT-45
03	B55 ATH 15-25D L90	SD48347		□25mm			BMT-55
04	B45 RTH 15-20 L106	SD48261		□20mm			BMT-45
05	B55 RTH 15-20 L104	SD48433		□20mm			BMT-55
06	B45 RTHDA 15-20/15° L114 HG	SD48122		□20mm			BMT-45
07	B45 RTHDA 15-20/11.25° L114 HG	SD48120		□20mm			BMT-45
08	B45 BTH 15-32/12 CH65/15° L90 HG	SD48121		Ø32mm/ Ø12mm	Internal & External Coolant Supply		BMT-45
09	B45 BTH 15-32/12 CH65/11.25° L90 HG	SD48119		Ø32mm/ Ø12mm			BMT-45
10	B45 BTH 15-32 CH65 L80	SD48049		Ø32mm			BMT-45
11	B45 BTH 15-32 CH85 L80	SD48341		Ø32mm			BMT-45
12	B55 BTH 15-40 CH60 L103	SD48019		Ø40mm			BMT-55
13	B55 BTH 15-40 CH70 L103	SD48032		Ø40mm			BMT-55
14	B55 BTH 15-40 CH100 L103	SD48020		Ø40mm			BMT-55
15	B45 BTH 15-32 CH65 L140	SD48262		Ø32mm	External Coolant Supply		BMT-45

DRIVEN TOOL HOLDERS

16	B45 ATH ER25 DIN1809 INT. NUT	SD7014		ER25	External Coolant Supply		BMT-45
17	B55 ATH ER25 DIN1809 INT. NUT	SD7116		ER25			BMT-55
18	B55 ATH ER32 DIN1809 INT. NUT	SD7114		ER32			BMT-55
19	B45 RTH ER25 CH65 DIN1809	SD7002		ER25	External Coolant Supply		BMT-45
20	B55 RTH ER25 CH70 DIN1809 INT. NUT	SD7108		ER25			BMT-55
21	B55 RTH ER32 CH70 DIN1809 INT. NUT	SD7129		ER32			BMT-55
22	B55 RTH ER25 CH85 DIN1809 INT. NUT	SD7130		ER25			BMT-55
23	B55 RTH ER32 CH85 DIN1809 INT. NUT	SD7131		ER32			BMT-55
24	B45 RTHD ER25 CH65 DIN1809	SD7016		ER25	External Coolant Supply		BMT-45
25	B45 RTHA ER20 DIN1809	SD7017		ER20			BMT-45

BMT-55 Tool Holders

Biglia BI55A/B, Biglia B301, B501, B650, B658, B1200, Biglia B446 T2, B465 T2, Biglia B446 T3, B465 T3, B545, B565, B745, B765, Biglia B620, Biglia B750, B1250 (16 station turret) Biglia BV210, BV315, Biglia Quattro B445, B470



STATIC TOOL HOLDERS

SL. NO.	Item Name	Item ID	3D-View of Tool that be used in Our Tool Holders	Tool Clamping	Coolant Supply Type	3D View	Application
01	B55 ATH 15-25.4 L100 BICL	SD58331		□1"	External Coolant Supply		USED FOR FACING & FACE GROOVING
02	B55 RTH 15-25.4 L121 BICL	SD58332		□1"			USED FOR OD TURNING, OD THREADING, PARTING & OD GROOVING
03	B55 BTH 15-31.75 CH100 L102 BICL	SD58333		Ø1 1/4"	Internal & External Coolant Supply		USED FOR 'U' DRILLING, BORING, DRILLING, INTERNAL THREADING, ID GROOVING
04	B55 BTH 15-38.1 CH100 L102 BICL	SD58104		Ø1 1/2"			

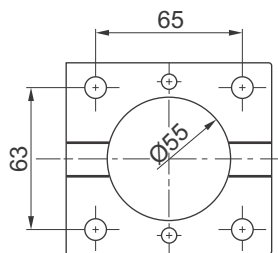

BOLT HOLE PATTERN - 65x63 MM

MD200 (100 / 180) 10 Station, MW 180 / 200 (EX) 10 Station, MS90 / 100 10 Station



STATIC TOOL HOLDERS

SL. NO.	Item Name	Item ID	3D-View of Tool that be used in Our Tool Holders	Tool Clamping	Coolant Supply Type	3D View	Application
01	CRTH 18-25 L178 MU	SD56421		□25mm	External Coolant Supply		USED FOR OD TURNING, OD THREADING, PARTING & OD GROOVING
02	CBTH 18-40 CH130 L185 MU TC	SD56499		∅40mm	Internal & External Coolant Supply		USED FOR 'U' DRILLING, BORING, DRILLING, INTERNAL THREADING, ID GROOVING
03	CATH 18-25 L175 MU	SD56554		□25mm	Internal & External Coolant Supply		USED FOR FACING & FACE GROOVING

BMT-45 Inch & Metric Tool Holders



STATIC TOOL HOLDERS

SL. NO.	Item Name	Item ID	3D-View of Tool that be used in Our Tool Holders	Tool Clamping	Coolant Supply Type	Application	3D View	
I	B45 ATH 15-19.05 L87	SD48373		□0.75"		180° REVERSABLE & USED FOR FACING & FACE GROOVING		
M	B45 ATH 15-20 L87	SD48079		□20mm				
I	B45 ATHM 15-19.05 L103	SD48622		□0.75"				
M	B45 ATHM 15-20 L103	SD48235		□20mm				
I	B45 RTH 15-19.05 L102	SD48625		□0.75"	External Coolant Supply	180° REVERSABLE & USED FOR OD TURNING, OD THREADING, PARTING & OD GROOVING		
M	B45 RTH 15-20 L102	SD48078		□20mm				
I	B45 RTH 15-19.05 L106	SD48626		□0.75"				
M	B45 RTH 15-20 L106	SD48261		□20mm				
I	B45 RTH 15-19.05 L108	SD58083		□0.75"				
M	B45 RTH 15-20 L108	SD58390		□20mm				
I	B45 RTH 15-25.4 L111	SD58076		□1.00"				
M	B45 RTH 15-25 L111	SD48653		□25mm				
I	B45 RTHD 15-19.05 L106	SD58082		□0.75"/ □20mm				
M	B45 RTH 15-19.05 L127	SD48627		□0.75"				
I	B45 RTH 15-20 L127	SD48258		□20mm				
M	B45 RTHM 15-19.05 L124	SD58289						□0.75"
I	B45 RTHM 15-20 L124	SD58130	□20mm					
M	B45 RTHM 15-19.05 L132	SD48375	□0.75"					
I	B45 RTHM 15-20 L132	SD48236	□20mm					
M	B45 RTHM 15-19.05 L164	SD48628	□0.75"					
I	B45 RTHM 15-20 L164	SD48259	□20mm					
M	B45 RTHMA 15-19.05 L136	SD48414	□0.75"		USED IN 24 STATION BMT TOOL DISC (A/F 320 HAVING 15° INDEXING OPTION)			
I	B45 RTHMA 15-20 L136	SD48065	□20mm					

BMT-45 Inch & Metric Tool Holders



STATIC TOOL HOLDERS

SL. NO.	Item Name	Item ID	3D-View of Tool that be used in Our Tool Holders	Tool Clamping	Coolant Supply Type	Application	3D View			
I	B45 BTH 15-25.4 CH65 L80	SD48376		Ø1.00"	Internal & External Coolant Supply	180° REVERSABLE & USED FOR 'U' DRILLING, BORING, DRILLING, INTERNAL THREADING, ID GROOVING				
M	B45 BTH 15-25 CH65 L80	SD48344		Ø25mm						
I	B45 BTH 15-31.75 CH65 L80	SD48377		Ø1.25"						
M	B45 BTH 15-32 CH65 L80	SD48049		Ø32mm						
I	B45 BTH 15-38.1 CH65 L80	SD48321		Ø1.50"						
M	B45 BTH 15-40 CH65 L80	SD48094		Ø40mm						
I	B45 BTH 15-31.75 CH85 L80	SD48624		Ø1.25"			External Coolant Supply			
M	B45 BTH 15-32 CH85 L80	SD48341		Ø32mm						
I	B45 BTH 15-31.75 CH85 L110	SD58077		Ø1.25"						
M	B45 BTH 15-32 CH85 L110	SD58382		Ø32mm						
I	B45 BTH 15-31.75 CH65 L95	SD58290		Ø1.25"						
M	B45 BTH 15-32 CH65 L95	SD58129		Ø32mm						
I	B45 BTH 15-38.1 CH65 L95	SD58081		Ø1.5"			External Coolant Supply			
M	B45 BTH 15-40 CH65 L95	SD58307		Ø40mm						
I	B45 BTH 15-31.75 CH65 L140	SD48623					Ø1.25"	External Coolant Supply		
M	B45 BTH 15-32 CH65 L140	SD48262					Ø32mm			
I	B45 BTHD 15-19.05 CH55/100 L90.5	SD58078		Ø0.75"	Internal & External Coolant Supply					
M	B45 BTHD 15-20 CH55/100 L90.5	SD58042		Ø20mm						
I	B45 BTHD 15-25.4 CH50/90 L80	SD58292		Ø1.00"						
M	B45 BTHD 15-25 CH50/90 L80	SD58271		Ø25mm						
I	B45 BTHD 15-19.05 CH55/100 L90.5 OFFSET 7.5	SD58079		Ø0.75"						
M	B45 BTHD 15-20 CH55/100 L90.5 OFFSET 7.5	SD58128		Ø20mm						
I	B45 BTHT 15-19.05 CH55/100/91.141 L92	SD58291		Ø0.75"	External Coolant Supply	USED IN 24 STATION BMT TOOL DISC (A/F 320 HAVING 15° INDEXING OPTION)				
M	B45 BTHT 15-20 CH55/100/91.141 L92	SD58002		Ø20mm						
I/M	B45 PTH-26	SD48090		SH26	External Coolant Supply	180° REVERSABLE & USED FOR PARTING WITH BLADE				

STATIC TOOL HOLDERS

ER25	B45 ATH ER25 DIN1809 INT. NUT	SD7014		ER25 RANGE 1-16	External Coolant Supply	USED FOR STRAIGHT (0°) OD DRILLING & OD SLOTTING & MILLING	
ER25	B45 ATH ER25 DIN1809 EXT. NUT	SD7001		ER25 RANGE 1-16			
ER25	B45 RTH ER25 CH65 DIN1809 EXT. NUT	SD7002		ER25 RANGE 1-16		180° REVERSABLE & USED FOR RIGHT ANGLE (90°) FACE DRILLING & MILLING	

BMT-55 Inch & Metric Tool Holders



STATIC TOOL HOLDERS

SL. NO.	Item Name	Item ID	3D-View of Tool that be used in Our Tool Holders	Tool Clamping	Coolant Supply Type	Application	3D View			
I	B55 ATH 15-25.4 L90	SD48217		□1.00"	External Coolant Supply	180° REVERSABLE & USED FOR FACING & FACE GROOVING				
M	B55 ATH 15-25 L90	SD48021		□25mm						
I	B55 ATH 15-25.4D L90	SD48655		□1.0"						
M	B55 ATH 15-25D L90	SD48347		□25mm						
I	B55 BTH 15-38.1 CH60 L103	SD48218		Ø1.50"	Internal & External Coolant Supply	180° REVERSABLE & USED FOR 'U' DRILLING, BORING, DRILLING, INTERNAL THREADING, ID GROOVING				
M	B55 BTH 15-40 CH60 L103	SD48019		Ø40mm						
I	B55 BTH 15-31.75 CH70 L103	SD48656		Ø1.25"						
M	B55 BTH 15-32 CH70 L103	SD58440		Ø32mm						
I	B55 BTH 15-38.1 CH70 L103	SD48219		Ø1.50"						
M	B55 BTH 15-40 CH70 L103	SD48032		Ø40mm						
I	B55 BTH 15-31.75 CH80 L103	SD48657		Ø1.25"						
M	B55 BTH 15-32 CH80 L103	SD48441		Ø32mm						
I	B55 BTH 15-38.1 CH85 L103	SD48829		Ø1.50"						
M	B55 BTH 15-40 CH85 L103	SD48691		Ø40mm						
I	B55 BTH 15-38.1 CH100 L103	SD48220		Ø1.50"						
M	B55 BTH 15-40 CH100 L103	SD48020		Ø40mm						
I	B55 BTH 15-38.1 CH115 L90	SD48658		Ø1.50"						
M	B55 BTH 15-40 CH115 L90	SD48328		Ø40mm						
I	B55 BTHD 15-19.05 CH75/130 L120	SD48659		Ø0.75"						
M	B55 BTHD 15-20 CH75/130 L120	SD48493		Ø20mm						
I	B55 RTH 15-19.05 L104	SD48661		□0.75"	External Coolant Supply	180° REVERSABLE & USED FOR OD TURNING, OD THREADING, PARTING & OD GROOVING				
M	B55 RTH 15-20 L104	SD48433		□20mm						
I	B55 RTH 15-25.4 L120	SD48660		□1.00"						
M	B55 RTH 15-25 L120	SD48418		□25mm						
I	B55 RTH 15-25.4 L139	SD48221		□1.00"						
M	B55 RTH 15-25 L139	SD48030		□25mm						
I	B55 RTHM 15-25.4 L152	SD48222					□1.0"	External Coolant Supply	USED FOR OD TURNING, OD THREADING & OD GROOVING IN MULTIPLE (M3 & M4) APPLICATIONS FOR MAIN & SUB SPINDLE	
M	B55 RTHM 15 -25 L152	SD48022					□25mm			
I	B55 RTHM 15-25.4 L188	SD48223					□1.0"			
M	B55 RTHM 15-25 L188	SD48031					□25mm			
I/M	B55 PTH -32	SD48054		SH32 BLADE WIDTH 32		180° REVERSABLE & USED FOR PARTING WITH BLADE				

BMT-55 Inch & Metric Tool Holders



BMT-55 AXIAL AND RADIAL DRIVEN TOOLS

SL. NO.	Item Name	Item ID	3D-View of Tool that be used in Our Tool Holders	Tool Clamping	Coolant Supply Type	Application	3D View
ER25	B55 ATH ER25 DIN1809 EXT.NUT	SD7136		ER25 RANGE 1-16	External Coolant Supply	USED FOR STRAIGHT (0°) OD DRILLING & OD SLOTTING & MILLING	
ER25	B55 ATH ER25 DIN1809 INT. NUT	SD7116		ER25 RANGE 1-16			
ER32	B55 ATH ER32 DIN1809 INT. NUT	SD7114		ER32 RANGE 2-20			
ER25	B55 RTH ER25 CH-70 DIN1809 EXT. NUT	SD7132		ER25 RANGE 1-16	External Coolant Supply	180° REVERSABLE & USED FOR RIGHT ANGLE (90°) FACE DRILLING & MILLING	
ER32	B55 RTH ER32 CH-70 DIN1809 EXT. NUT	SD7133		ER32 RANGE 2-20			
ER25	B55 RTH ER25 CH-85 DIN1809 EXT. NUT	SD7134		ER25 RANGE 1-16			
ER32	B55 RTH ER32 CH-85 DIN1809 EXT. NUT	SD7135		ER32 RANGE 2-20			
ER25	B55 RTH ER25 CH-70 DIN1809 INT. NUT	SD7108		ER25 RANGE 1-16			
ER32	B55 RTH ER32 CH-70 DIN1809 INT. NUT	SD7129		ER32 RANGE 2-20			
ER25	B55 RTH ER25 CH-85 DIN1809 INT. NUT	SD7130		ER25 RANGE 1-16			
ER32	B55 RTH ER32 CH-85 DIN1809 INT. NUT	SD7131		ER32 RANGE 2-20			

BMT-65 Inch & Metric Tool Holders



STATIC TOOL HOLDERS

SL. NO.	Item Name	Item ID	3D-View of Tool that be used in Our Tool Holders	Tool Clamping	Coolant Supply Type	Application	3D View				
I	B65 ATH 18-25.4 L100	SD48415		□1.0"	External Coolant Supply	180° REVERSABLE & USED FOR RIGHT ANGLE (90°) FACE DRILLING & MILLING					
M	B65 ATH 18-25 L100	SD48444		□25mm							
I	B65 ATH 15-25.4 L115	SD48225		□1.0"							
M	B65 ATH 15-25 L115	SD48026		□25mm							
I	B65 ATH 18-25.4 L125	SD48226		□1.0"							
M	B65 ATH 18-25 L125	SD48069		□25mm							
I	B65 ATH 18-25.4 H85	SD48664		□1.0"							
M	B65 ATH 18-25 H85	SD48412		□25mm							
I	B65 ATH 18-25.4 H115	SD48665		□1.0"							
M	B65 ATH 18-25 H115	SD48413		□25mm							
I	B65 BTH 18-38.1 CH72 L127	SD48227						Ø1.50"	Internal & External Coolant Supply	180° REVERSABLE & USED FOR 'U' DRILLING, BORING, DRILLING, INTERNAL THREADING, ID GROOVING	
M	B65 BTH 18-40 CH72 L127	SD48025						Ø40mm			
I	B65 BTH 18-50.8 CH72 L127	SD48832						Ø2.0"			
M	B65 BTH 18-50 CH72 L127	SD48315						Ø50mm			
I	B65 BTH 18-38.1 CH100 L120	SD48663						Ø1.50"			
M	B65 BTH 18-40 CH100 L120	SD48508						Ø40mm			
I	B65 BTH 18-50.8 CH80 L120	SD48424	Ø2.0"								
M	B65 BTH 18-50 CH80 L120	SD48833	Ø50mm								
I	B65 BTH 18-38.1 CH100 L127	SD48228	Ø1.50"								
M	B65 BTH 18-40 CH100 L127	SD48033	Ø40mm								
I	B65 BTH 18-38.1 CH115 L127	SD48229	Ø1.50"								
M	B65 BTH 18-40 CH115 L127	SD48027	Ø40mm								
I	B65 BTHD 18-25.4 CH65/120 L127	SD48716	Ø1.0"								
M	B65 BTHD 18-25 CH65/120 L127	SD48830	Ø25mm								
I	B65 BTHD 18-31.75 CH65/120 L127	SD48314	Ø1.25"								
M	B65 BTHD 18-32 CH65/120 L127	SD48313	Ø32mm								
I	B65 BTHD 18-25.4 CH85/130 L121	SD48263	Ø1.0"								
M	B65 BTHD 18-25 CH85/130 L121	SD48606	Ø25mm								
I	B65 RTH 18-25.4 L130	SD48230		□1.0"	External Coolant Supply	180° REVERSABLE & USED FOR OD TURNING, OD THREADING, PARTING & OD GROOVING					
M	B65 RTH 18-25 L130	SD48024		□25mm							
I	B65 RTH 18-25.4 L104	SD48231		□1.0"							
M	B65 RTH 18-25 L104	SD48073		□25mm							
I	B65 RTH 18-25.4 L150-32	SD48834		□1.0"							
M	B65 RTH 18-25 L150-32	SD48502		□25mm							
I	B65 RTHM 18 -25.4 L151	SD48814		□1.0"	External Coolant Supply	USED FOR OD TURNING, OD THREADING & OD GROOVING IN MULTIPLE (M3 & M4) APPLICATIONS FOR MAIN & SUB SPINDLE					
M	B65 RTHM 18 -25 L151	SD48826		□25mm							
M	B65 PTH -32	SD48034		SH32 BLADE WIDTH 32	External Coolant Supply	180° REVERSABLE & USED FOR PARTING WITH BLADE					

BMT-65 Inch & Metric Tool Holders

SPHOORTI
América Latina



DRIVEN TOOL HOLDERS

SL. NO.	Item Name	Item ID	3D-View of Tool that be used in Our Tool Holders	Tool Clamping	Coolant Supply Type	Application	3D View
ER32	B65 ATH ER32 DIN1809 INT. NUT	SD7204		ER32 RANGE 2-20	External Coolant Supply	USED FOR STRAIGHT (0°) OD DRILLING & OD SLOTTING & MILLING	
ER32	B65 ATH ER32 DIN1809 EXT. NUT	SD7223		ER32 RANGE 2-20			
ER32	B65 RTH ER32 CH72 DIN1809 INT. NUT	SD7217		ER32 RANGE 2-20	External Coolant Supply	180° REVERSABLE & USED FOR RIGHT ANGLE (90°) FACE DRILLING & MILLING	
ER32	B65 RTH ER32 CH100 DIN1809 INT. NUT	SD7215		ER32 RANGE 2-20			
ER32	B65 RTH ER32 CH72 DIN1809 EXT. NUT	SD7220		ER32 RANGE 2-20			
ER32	B65 RTH ER32 CH100 DIN1809 EXT. NUT	SD7226		ER32 RANGE 2-20			

BMT-75 Inch & Metric Tool Holders



STATIC TOOL HOLDERS

SL. NO.	Item Name	Item ID	3D-View of Tool that be used in Our Tool Holders	Tool Clamping	Coolant Supply Type	Application	3D View	
I	B75 ATH 18-25.4 L140	SD48269		□1.00"	External Coolant Supply	180° REVERSABLE & USED FOR FACING & FACE GROOVING		
M	B75 ATH 18-25 L140	SD48002		□25mm				
I	B75 ATH 18-31.75 L135	SD48690		□1.25"				
M	B75 ATH 18-32 L135	SD48686		□32mm				
I	B75 BTH 25-50.8 CH60 L165	SD48270		Ø2.0"	Internal & External Coolant Supply	180° REVERSABLE & USED FOR 'U' DRILLING, BORING, DRILLING, INTERNAL THREADING, ID GROOVING		
M	B75 BTH 25-50 CH60 L165	SD48004		Ø50mm				
I	B75 BTH 25-63.5 CH60 L165	SD48271		Ø2.50"				
M	B75 BTH 25-60 CH60 L165	SD48003		Ø60mm				
I	B75 BTH 25-63.5 CH90 L165	SD48272		Ø2.50"				
M	B75 BTH 25-60 CH90 L165	SD48256		Ø60mm				
I	B75 BTH 25-63.5 CH110 L137	SD48672		Ø2.50"				
M	B75 BTH 25-60 CH110 L137	SD48671		Ø60mm				
I	B75 RTH 25-25.4 L165	SD48273		□1.0"	External Coolant Supply	180° REVERSABLE & USED FOR OD TURNING, OD THREADING, PARING & OD GROOVING		
M	B75 RTH 25-25 L165	SD48001		□25mm				
I	B75 RTH 25-31.75 L168	SD48677		□1.25"				
M	B75 RTH 25-32 L168	SD48005		□32mm				
I	B75 RTH 25-25.4 L145.5	SD48673		□1.0"				
M	B75 RTH 25-25 L145.5	SD48434		□25mm				
I	B75 RTH 25-31.75 L150.5	SD48676		□1.25"				
M	B75 RTH 25-32 L150.5	SD48435		□32mm				
I	B75 RTH 25-31.75 L153	SD48675		□1.25"				
M	B75 RTH 25-32 L153	SD48674		□32mm				
I	B75 RTHM 25 -31.75 L181	SD48678		□1.25"				
M	B75 RTHM 25 -32 L181	SD48438		□32mm				

DRIVEN TOOL HOLDERS

ER32	B75 ATH ER32 DIN1809 EXT. NUT	SD7301		ER32 RANGE 2-20	External Coolant Supply	USED FOR STRAIGHT (0°) OD DRILLING & OD SLOTTING & MILLING	
ER40	B75 ATH ER40 DIN1809 EXT. NUT	SD7303		ER40 RANGE 3-26			
ER40	B75 RTH ER40 CH60 DIN1809 EXT. NUT CW	SD7305		ER40 RANGE 3-26		180° REVERSABLE & USED FOR RIGHT ANGLE (90°) FACE DRILLING & MILLING	
ER40	B75 RTH ER40 CH110 DIN1809 EXT. NUT CW	SD7311		ER40 RANGE 3-26			

Taper Shank Standards

DIN 69871/DIN 2080 Shank Details

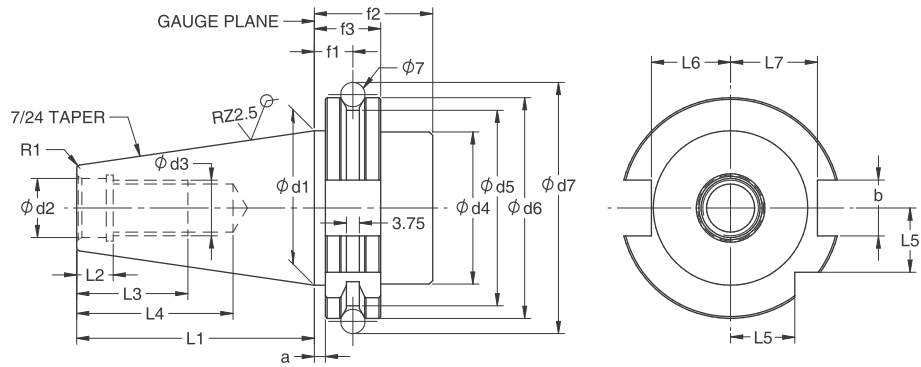

Designation	a ± 0.1	b H12	φd1	φd3	φd2 H7	φd7 ± 0.05	φd6 -0.1	φd5 -0.5	φd4 max	f1 ± 0.1
SK30	3.2	16.1	31.75	M12	13	59.3	50	44.3	45	11.1
SK40	3.2	16.1	44.45	M16	17	72.3	63.55	56.25	50	11.1
SK50	3.2	25.7	69.85	M24	25	107.25	97.50	91.25	80	11.1
Designation	f2 min	f3 -0.1	L1 -0.3	L2 +0.5	L3 min	L4 min	L5 -0.3	L6 -0.4	L7 -0.4	R1
SK30	35	19.1	47.8	5.5	24	33.5	15	16.4	19	0.6
SK40	35	19.1	68.4	8.2	32	42.5	18.5	22.8	25	1.2
SK50	35	19.1	101.75	11.5	47	61.5	30	35.5	37.7	2.5

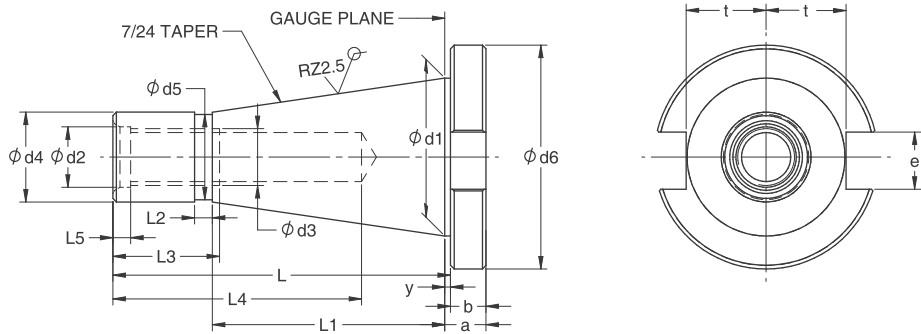

Designation	φd1 Basic	φd4 a10	φd5	L max	L1	L2	y ± 0.4	φd6 a10	a ± 0.1
ISO30	31.75	17.4	16.5	70	50	3	1.6	50	9.6
ISO40	44.45	25.3	24	95	67	5	1.6	63	11.6
ISO50	69.85	39.6	38	130	105	8	3.2	100/95	15.2
Designation	b	e H12	t max	φd3	φd2	L5	L3	L4 min	
ISO30	8	16.1	16.2	M12	12.5	3	24	50	
ISO40	10	16.1	22.5	M16	17	4.5	30	70	
ISO50	12	25.7	35.3	M24	25	6	45	90	

Taper Shank Standards

HSK Shank Details - A, C, E and F

Shape A

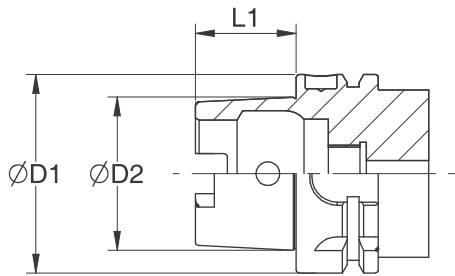

Shape B

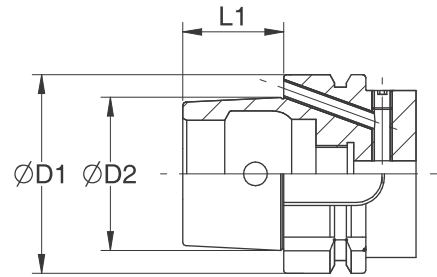

Hollow-shank taper for automatic tool changing with gripping and locating groove. Manual operation is possible through the access hole in the taper. Torque is transmitted both positively and non-positively.

Shape C

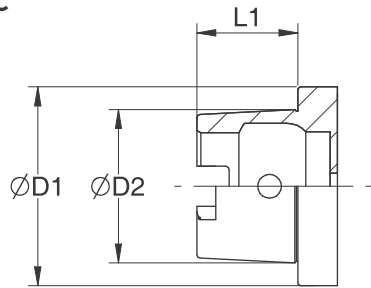

Shape D

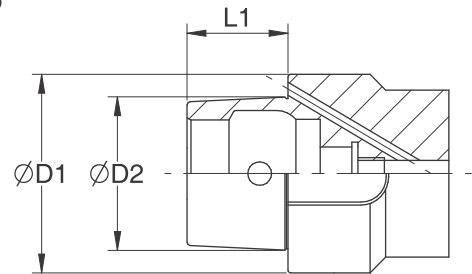

Hollow-shank taper for manual tool changing. operation is possible through the access hole in the taper. Torque is transmitted both positively and non-positively.

Shape E

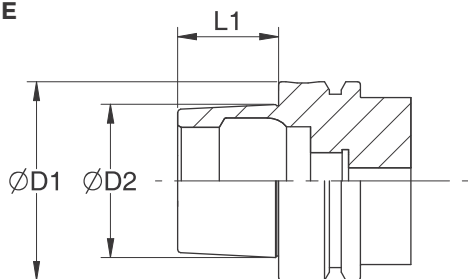

Shape F

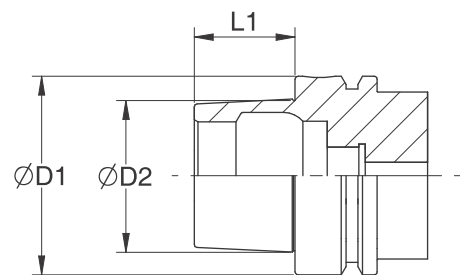

Hollow-shank taper for automatic tool changing (manual operation through access hole in taper not possible). Torque is transmitted non-positively.

HSK Shape A,C,E			HSK Shape B,D,F		
Nominal Size ØD1 (mm)	ØD2 (mm)	L1 (mm)	Nominal Size ØD1 (mm)	ØD2 (mm)	L1 (mm)
25	19	13	-	-	-
32	24	16	-	-	-
40	30	20	40	24	16
50	38	25	50	30	20
63	48	32	63	38	25
80	60	40	80	48	32
100	75	50	100	60	40

Tap Standards ANSI / Metric

ANSI Shank							Metric Shank												
metric thread ANSI Shank	Tap #	fract. Dia.	inch shank Dia.	inch square	Dia (mm)	square (mm)	inch shank Dia.	inch square	Dia (mm)	square (mm)	DIN352 hand tap short	DIN353 inch	DIN371 strong shank	DIN376 DIN374 normal + fine	DIN2182 normal inch	DIN2183 out of range inch	ISO 529	JIS	JIS INCH
M1.6	0		0.141	0.110	3.58	2.79	0.098	0.083	2.50	2.1	M1		M1	M3.5	1/16"	1/16"			
M1.8	1		0.141	0.110	3.58	2.79	0.098	0.083	2.50	2.1	M1.1		M1.1						
M2,M2.2	2		0.141	0.110	3.58	2.79	0.098	0.083	2.50	2.1	M1.2		M1.2						
M2.5	3		0.141	0.110	3.58	2.79	0.098	0.083	2.50	2.1	M1.4		M1.4						
	4		0.141	0.110	3.58	2.79	0.098	0.083	2.50	2.1	M1.6		M1.6						
M3,M3.15	5	1/8"	0.141	0.110	3.58	2.79	0.098	0.083	2.50	2.1	M1.8		M1.8						
M3.5	6		0.141	0.110	3.58	2.79	0.110	0.083	2.80	2.1	M2		M2	M4	3/32"	5/32"			
	7		0.168	0.130	4.26	3.3	0.110	0.083	2.80	2.1	M2.2		M2.2						
M4	8	5/32"	0.168	0.130	4.26	3.3	0.110	0.083	2.80	2.1	M2.5		M2.5						
	9		0.194	0.152	4.93	3.86	0.110	0.088	2.80	2.24								M2.5	
M5	10	3/16"	0.194	0.152	4.93	3.86	0.118	0.098	3	2.5								M2.5	#3
	12	7/32"	0.220	0.165	5.59	4.19	0.124	0.098	3.15	2.5								#8	
M6,M6.3	14	1/4"	0.247	0.185	6.27	4.7	0.124	0.110	3.15	2.8								#4	
	16		0.273	0.205	6.93	5.2	0.138	0.106	3.5	2.7	M3		M3	M5	1/8"			#6	
	18		0.299	0.225	7.59	5.71	0.140	0.110	3.55	2.8								#6	
	20		0.325	0.244	8.25	6.2	0.157	0.118	4	3	M3.5		M3.5 #6		7/32"				
		5/32"	0.160	0.122	4.06	3.1	0.157	0.126	4	3.2								M3	#5, #6
		3/16"	0.192	0.149	4.88	3.78	0.177	0.134	4.5	3.4	M4		M4	M6	5/32"	1/4"			
		7/32"	0.223	0.167	5.66	4.24	0.197	0.157	5	4								#10	M4, M5 #8
		1/4"	0.255	0.191	6.48	4.85	0.217	0.177	5.5	4.5									M4, M5.5 #10
M7,M8		9/32"	0.286	0.214	7.26	5.44	0.220	0.177	5.6	4.5								#12	M6 1/4"-20
		5/16"	0.318	0.238	8.08	6.05	0.236	0.177	6	4.5									
		11/32"	0.349	0.262	8.86	6.65	0.236	0.193	6	4.9	M5		M5						
M10		3/8"	0.381	0.286	9.68	7.26	0.236	0.193	6	4.9	M6,M8		M6	M8					
		13/32"	0.323	0.242	8.20	6.15	0.240	0.197	6.1	5									M6 M8, M7 5/16"-18
		7/16"	0.323	0.242	8.20	6.15	0.244	0.197	6.20	5									
		15/32"	0.354	0.265	8.99	6.73	0.248	0.197	6.30	5								1/4"-20	
M12, M12.5		1/2"	0.367	0.275	9.32	6.99	0.276	0.217	7	5.5	M10	G1/8"		M10	1/4"	3/8"			M10, M9
		17/32"	0.398	0.298	10.11	7.57	0.315	0.236	8	6									M11 1/8"
M14		9/16"	0.429	0.322	10.90	8.18	0.315	0.244	8	6.2			M8		5/16"	7/16"			
		19/32"	0.460	0.345	11.68	8.76	0.315	0.248	8	6.3								5/16"-18	
M16		5/8"	0.480	0.360	12.19	9.14	0.335	0.256	8.5	6.5									M12
		21/32"	0.511	0.383	12.96	9.73	0.354	0.276	9	7				M12	3/8"	1/2"			M12
M18		11/16"	0.542	0.406	13.77	10.31	0.394	0.315	10	8			M10						
		23/32"	0.573	0.430	14.55	10.92	0.413	0.315	10.5	8									M14, M15
		3/4"	0.590	0.442	14.99	11.23	0.433	0.354	11	9	M14	G1/4"		M14		9/16"			1/4"
		25/32"	0.621	0.466	15.77	11.84	0.472	0.354	12	9	M16	G3/8"		M16		5/8"			M14, M15
M20		13/16"	0.652	0.489	16.56	12.42	0.492	0.394	12.5	10								M16	M16
		27/32"	0.684	0.513	17.37	13.03	0.512	0.394	13	10									M17

Tap Standards ANSI / Metric

ANSI Shank							Metric Shank													
metric thread ANSI Shank	Tap #	fract. Dia.	inch shank Dia.	inch square	Dia (mm)	square (mm)	inch shank Dia.	inch square	Dia (mm)	square (mm)	DIN352 hand tap short	DIN353 inch	DIN371 strong shank	DIN374 normal + fine	DIN2182 normal inch	out of range inch	ISO 529	JIS	JIS INCH	
M22		7/8"	0.697	0.523	17.70	13.28	0.551	0.433	14	11	M18			M18		11/16"		M18	3/8"	
							0.551	0.441	14	11.2							M18			
M24		15/16"	0.760	0.570	19.30	14.48	0.591	0.472	15	12								M20		
M25		1"	0.800	0.600	20.32	15.24	0.630	0.472	16	12	M20	G1/2"		M20		13/16"				
M27		1-1/16"	0.862	0.646	21.89	16.41	0.669	0.512	17	13								M22		
		1-1/8"	0.896	0.672	22.76	17.07	0.709	0.551	18	14									1/2"	
M30		1-3/16"	0.959	0.719	24.36	18.26	0.709	0.571	18	14.5	M22	G5/8"		M22		7/8"				
		1-1/4"	1.021	0.766	25.93	19.46	0.709	0.571	18	14.5	M24			M24		15/16"				
M33		1-5/16"	1.084	0.813	27.53	20.65	0.748	0.591	19	15								M24, M25	1/2"NPT	
		1-3/8"	1.108	0.831	28.14	21.11	0.787	0.591	20	15								M26, M27		
M36		1-7/16"	1.171	0.878	29.74	22.3	0.787	0.630	20	16	M27	G3/4"		M27		1"				
		1-1/2"	1.233	0.925	31.32	23.5	0.827	0.669	21	17								M28		
M39		1-5/8"	1.305	0.979	33.15	24.87	0.866	0.669	22	17								M28		
M42		1-3/4"	1.430	1.072	36.32	27.23	0.866	0.709	22	18	M30	G7/8"		M30		1-1/8"				
		1-7/8"	1.519	1.139	38.58	28.93	0.906	0.669	23	17								M30	3/4"	
M48		2"	1.644	1.233	41.76	31.32	0.945	0.748	24	19								M32	3/4"NPT	
							0.984	0.748	25	19								M33		
							0.984	0.787	25	20	M33	G1"		M33		1-1/4"				
Pulley Taps																				
M6		1/4"	0.255	0.191	6.48	4.85	1.024	0.827	26	21								M35, M34	1"	
M8		5/16"	0.318	0.238	8.08	6.04	1.102	0.827	28	21								M36, M38	1" NPT	
M10		3/8"	0.381	0.286	9.68	7.26	1.102	0.866	28	22	M36	G1-1/8"		M36		1-3/8"				
		7/16"	0.444	0.333	11.28	8.46	1.102	0.882	28	22.4										
		1/2"	0.504	0.380	12.80	9.65	1.181	0.906	30	23								M39, M40		
		5/8"	0.633	0.475	16.08	12.06	1.260	0.945	32	24	M39	G1-1/4"		M39		1-1/2"				
		3/4"	0.756	0.569	19.20	14.45	1.260	0.945	32	24	M42	G1-1/4"		M42		1-5/8"				
Pipe Taps																				
		1/8"SS	0.313	0.234	7.94	5.94	1.260	1.024	32	26								M42	1-1/4"	
		1/8"LS	0.437	0.328	11.11	8.33	1.378	1.024	35	26								M45	1-3/8"	
		1/4"	0.563	0.421	14.29	10.69	1.417	1.142	36	29	M45	G1-3/8"		M45		1-3/4"				
		3/8"	0.700	0.531	17.78	13.49	1.417	1.142	36	29	M48	G1-1/2"		M48		1-7/8"				
		1/2"	0.687	0.515	17.46	13.08	1.417	1.142	36	29		G1-3/4"								
		5/8"	0.813	0.594	20.64	15.09	1.496	1.142	38	29		G2"						M48	1-1/2"	
		3/4"	0.906	0.679	23.02	17.25	1.575	1.260	40	32	M52	G2-1/4"		M52		2"				
		7/8"	1.094	0.812	27.78	20.62	1.772	1.378	45	35	M56	G2-1/2"		M56		2-1/4"				
		1"	1.125	0.843	28.57	21.41	1.772	1.378	45	35	M60			M60		2-1/2"				
		1-1/4"	1.313	0.984	33.34	24.99	1.969	1.535	50	39	M64	G2-3/4"		M64		2-1/2"				
		1-3/8"	1.108	0.831	28.14	21.11	2.205	1.732	56	44	M68	G3-1/4"		M68		2-3/4"				
		1-1/2"	1.500	1.125	38.10	28.57	2.205	1.732	56	44						3"				

Accutek Manufacturing Tips

Accutek Manufacturing Tip #4

Types of Improper Tool holder wear and/or damage – The average tool holder shank, whether HSK, CAT, BT, or Steep taper Face contact has a “dimension life” of about 3-5 years. This means most tool holders, regardless of brand, are usually worn beyond new “Standard ANSI or DIN” specifications. This “wear” means your tools are no longer maintaining proper spindle taper/tool shank taper contact, TIR accuracy, or even proper spindle taper alignment. All this “Wear” means your machining processes are fighting to maintain centerline and highest level of machine spindle and toolholder interface. Types of wear and causes:



Normal wear

- 1) Even surface wear pattern from flange back towards retention knob end.
 - 2) No nicks or dents that cause high spots or low spots on taper
- Proper tool holder and spindle care:
- 1) Make sure tool taper is clean before inserting into tool carousel or machine spindle
 - 2) Make sure you use a spindle taper wiper every day
 - 3) Store tool holders in clean environment and sprayed with rust preventing lubricant is being store longer than 14 days
 - 4) DO NOT store tool holders in metal or wood storage racks – wood hold moisture and will cause rust. Steel will scratch or dent taper.

Fretting (not rust!)

- Causes:
- 1) Poor drawbar force pressure
 - 2) Excessive radial load on cutting tool/holder assembly
 - 3) Spindle taper surface in poor condition or bell mouth
- Resolutions:
- 1) Check drawbar force to make sure in is within factory specifications
 - 2) Reduce radial load on application
 - 3) Check spindle taper and tool holder taper for “out of specification” dimensions and spindle bell mousing

Uneven Taper Wear

- Causes:
- 1) Over torque of Retention Knobs
 - 2) Incorrect Retention knob for machine spindle
 - 3) Poor quality tool holder material or heat treatment and grind
- Resolutions:
- 1) Torque specifications for retention knob
 - 2) Check Drawbar Force
 - 3) Conduct Taper/Spindle Bluing process to see if tool taper or machine taper is correct.



Accutek Inc.

15 W. Commercial Ave., Addison IL 60101-4501
info@accutekusa.com
+1 (312) 857-6577

www.accutekusa.com