

www.neidlein.de



NEIDLEIN

SPANNZEUGE GmbH

Tools for Clamping between Centers

process oriented for turning, hard turning, grinding and milling

Face Drivers FSB / SB



with drive pins and movable center pin

The entire surface of the workpiece can be tooled and finished by clamping with a maximum of torque transmission. NEIDLEIN face drivers are mechanical clamping systems which are suited **for turning as well as hard turning.**

Face drivers of type FSB / SB are power-operated by the thrust of the tailstock. Workpieces are clamped centrally using a movable center pin. This way different centerings can be adjusted, thus ensuring a constant datum-point at the end face of the workpieces.

Type FSB with flange retainer

Type FSB is mounted onto the machine spindle nose using a flange adapter.



Type SB with MK- or cylindrical retainer

Type SB with taper shank and extracting nut for fast mounting into the machine spindle.



NEIDLEIN face drivers FSB / SB with movable center pins ensure:

- a maximum of torque transmission, thus achieving high metal removing rates
- datum-point at the end face of the workpiece
stable datum-point in case of different centerings
- extended tool-life of driving devices and cutting tools due to vibration-free running
- run-out deviation max.: 0.015 - 0.02 mm
- clamping force is triggered by tailstock
- fixed center pin/fixed datum-point in clamped state
- compensating driving devices/ideal clamping of the workpiece
- simple handling

Clamping principle

The center pin located on the side of the tailstock pushes the workpiece against the movable center pin of the face driver. The center pin will draw back until the surface of the workpiece bears against the drive pins. In this state the clamping bolt is clamped over the power flow in order to ensure a fixed datum-point during the entire tooling process.

The drive pins are "floatingly", thus compensating for variations in workpiece, squareness and surface finish. The entire surface of the workpiece can now be finished in one single clamping. Please check page 14 - 15 for metal removing rates to be obtained as well as for the tailstock forces required. Compatible standard drive pins and center pins are listed on page 22 - 28.

We will be glad to design clamping devices suitable for your workpieces.

Type FSB with flange retainer

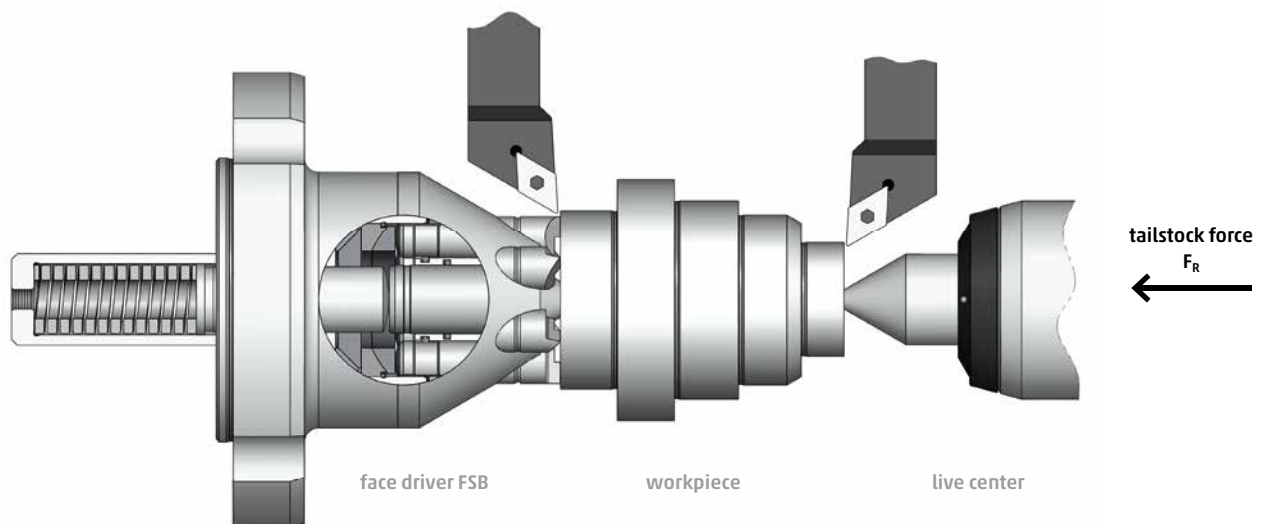

Technical data – type FSB face driver

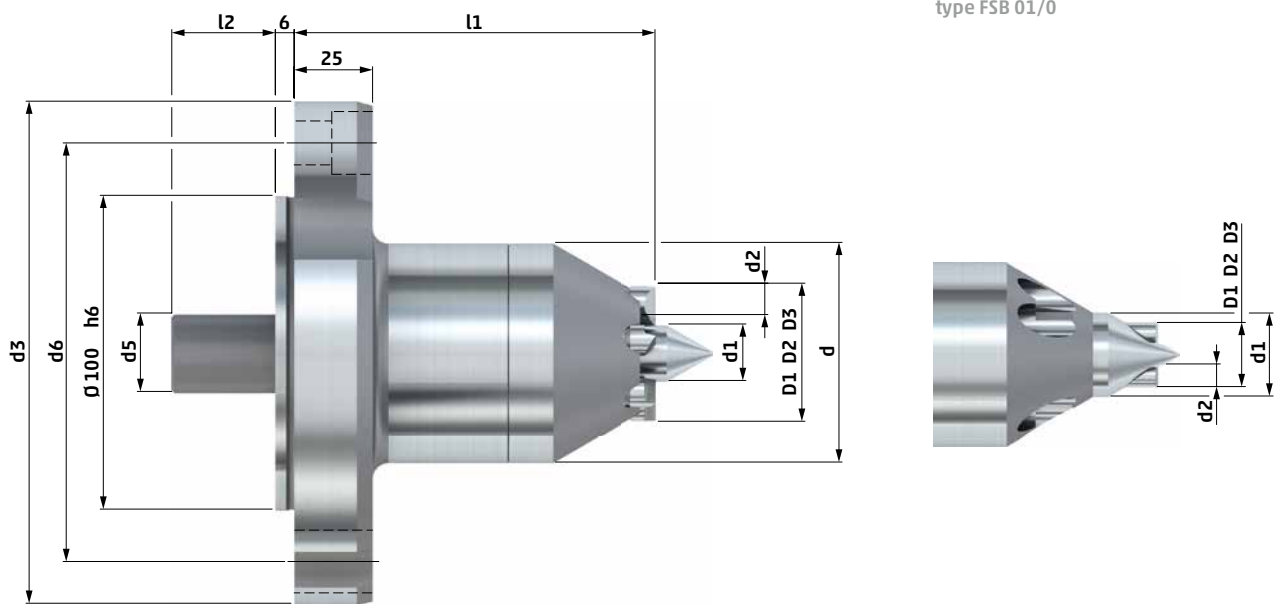

| type FSB | d | d1 | center Ø | d2 | d3 | d5 | d6 | l1 | l2 | drive pin | fastening screw | | clamping Ø | | | cat. no. |
|-------------|-----|----|----------|----|-----|----|-------|-----|-----|-----------|-----------------|-----|------------|-----|-----|---------------|
| | | | | | | | | | | | type | pcs | D1 | D2 | D3 | |
| 01 | 48 | 22 | 0 - 5 | 6 | 160 | 25 | 133.4 | 115 | 28 | 3 | M12 | 3 | 8 | 11 | 17 | 730 12 |
| 0 | 48 | 22 | 0 - 3 | 8 | 160 | 25 | 133.4 | 115 | 28 | 3 | M12 | 3 | 6 | 11 | 19 | 730 01 |
| 11 | 42 | 6 | 0 - 6 | 6 | 160 | 25 | 133.4 | 115 | 28 | 3 | M12 | 3 | 11 | 14 | 20 | 730 11 |
| 1 | 48 | 8 | 0 - 8 | 8 | 160 | 25 | 133.4 | 115 | 28 | 3 | M12 | 3 | 13 | 18 | 26 | 730 02 |
| 2 | 70 | 14 | 2 - 14 | 10 | 160 | 25 | 133.4 | 115 | 23 | 6 | M12 | 3 | 26 | 31 | 36 | 730 03 |
| 3 | 70 | 18 | 2 - 18 | 10 | 160 | 25 | 133.4 | 115 | 33 | 6 | M12 | 3 | 34 | 39 | 44 | 730 04 |
| 35 | 80 | 14 | 2 - 14 | 15 | 160 | 25 | 133.4 | 115 | 33 | 6 | M12 | 3 | 29 | 39 | 49 | 730 09 |
| 4 | 90 | 24 | 3 - 24 | 15 | 160 | 32 | 133.4 | 115 | 72 | 6 | M12 | 3 | 39 | 49 | 59 | 730 05 |
| 45 | 100 | 28 | 3 - 28 | 15 | 160 | 32 | 133.4 | 115 | 72 | 6 | M12 | 3 | 49 | 59 | 69 | 730 10 |
| 5 | 132 | 35 | 3 - 35 | 20 | 160 | 45 | 133.4 | 115 | 164 | 6 | M12 | 3 | 69 | 84 | 99 | 730 06 |
| 55 | 182 | 35 | 3 - 35 | 20 | 220 | 45 | 171.4 | 115 | 165 | 6 | M16 | 3 | 110 | 125 | 140 | 730 08 |
| 6 | 212 | 35 | 3 - 35 | 20 | 250 | 45 | 210 | 115 | 165 | 6 | M20 | 3 | 140 | 155 | 170 | 730 07 |
| 7 | 255 | 50 | 25 - 48 | 20 | 290 | 50 | 250 | 132 | 165 | 6 | M20 | 6 | 180 | 195 | 210 | 730 13 |
| 75 | 302 | 50 | 25 - 48 | 20 | 348 | 50 | 310 | 132 | 165 | 6 | M20 | 6 | 230 | 245 | 260 | 730 14 |
| 8 | 360 | 80 | 30 - 76 | 30 | 440 | 78 | 394 | 190 | 262 | 6 | M20 | 6 | 270 | 290 | 310 | 730 16 |
| 85 | 410 | 80 | 30 - 76 | 30 | 490 | 78 | 444 | 190 | 262 | 6 | M20 | 6 | 320 | 340 | 360 | 730 15 |

- All face drivers are supplied without drive pins. (drive pins see page 22 - 27)
- Types FSB 01 / 0 are supplied with center body, all other types without center pin. (center pins see page 28)
- Mounting elements for face drivers see page 76 - 73.

It is the purpose of a flange-adapter to provide stable connection to the machine spindle. We supply these flange adapters for various sizes of spindle noses either in standard size (DIN ISO 702-1 / DIN 55028) or for spindle noses specific to manufacturer of machine-tools. Thus face drivers of type FSB can be used on different machines. Driving devices and center pins can be exchanged front view on the machine without any effort.

Upon request and depending on the tooling direction of the machine the face driver can be equipped optionally with drive pins for counter-clockwise tooling (SR / tooling direction M3), for clockwise tooling (SL / tooling direction M4) or for both tooling directions (NV = bi-directional).

Apart from the clamping diameters listed in the table under D1, D2, D3 we can also supply intermediate dimensions upon request. We can as well make extra-large center pins or mushroom centers appropriate to oversized centerings in workpieces. (see page 30)

Technical data – type SB face driver

type SB 01/0

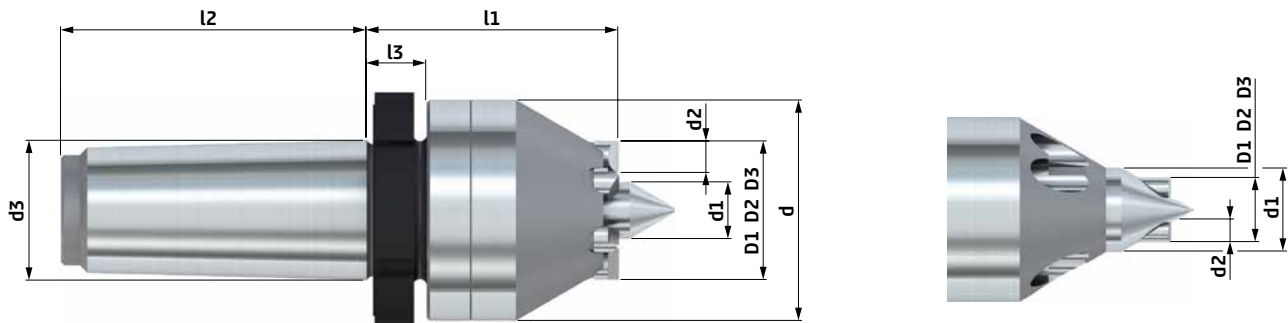

| type SB | MK | d | d1 | center Ø | d2 | d3 | l1 | l2 | l3 | drive pin | clamping Ø | | | cat. no. |
|------------|----|-----|----|----------|----|-----------|-----|-----|----|-----------|------------|-----|-----|---------------|
| | | | | | | | | | | | D1 | D2 | D3 | |
| 01 | 3 | 48 | 22 | 0 - 5 | 6 | M28 x 1.5 | 87 | 61 | 14 | 3 | 8 | 11 | 17 | 720 16 |
| | 4 | 48 | 22 | 0 - 5 | 6 | M35 x 1.5 | 87 | 74 | 16 | 3 | 8 | 11 | 17 | 720 17 |
| | 5 | 48 | 22 | 0 - 5 | 6 | M48 x 1.5 | 87 | 97 | 19 | 3 | 8 | 11 | 17 | 720 18 |
| 0 | 3 | 48 | 22 | 0 - 3 | 8 | M28 x 1.5 | 87 | 61 | 14 | 3 | 6 | 11 | 19 | 720 01 |
| | 4 | 48 | 22 | 0 - 3 | 8 | M35 x 1.5 | 87 | 74 | 16 | 3 | 6 | 11 | 19 | 720 02 |
| | 5 | 48 | 22 | 0 - 3 | 8 | M48 x 1.5 | 87 | 97 | 19 | 3 | 6 | 11 | 19 | 720 03 |
| 11 | 3 | 42 | 6 | 0 - 6 | 6 | M28 x 1.5 | 80 | 61 | 14 | 3 | 11 | 14 | 20 | 720 19 |
| | 4 | 42 | 6 | 0 - 6 | 6 | M35 x 1.5 | 80 | 74 | 16 | 3 | 11 | 14 | 20 | 720 20 |
| | 5 | 42 | 6 | 0 - 6 | 6 | M48 x 1.5 | 80 | 97 | 19 | 3 | 11 | 14 | 20 | 720 21 |
| 1 | 3 | 48 | 8 | 0 - 8 | 8 | M28 x 1.5 | 80 | 61 | 14 | 3 | 13 | 18 | 26 | 720 04 |
| | 4 | 48 | 8 | 0 - 8 | 8 | M35 x 1.5 | 80 | 74 | 16 | 3 | 13 | 18 | 26 | 720 05 |
| | 5 | 48 | 8 | 0 - 8 | 8 | M48 x 1.5 | 80 | 97 | 19 | 3 | 13 | 18 | 26 | 720 06 |
| 2 | 4 | 70 | 14 | 2 - 14 | 10 | M35 x 1.5 | 80 | 74 | 16 | 6 | 26 | 31 | 36 | 720 07 |
| | 5 | 70 | 14 | 2 - 14 | 10 | M48 x 1.5 | 80 | 97 | 19 | 6 | 26 | 31 | 36 | 720 08 |
| 3 | 4 | 70 | 18 | 2 - 18 | 10 | M35 x 1.5 | 80 | 74 | 16 | 6 | 34 | 39 | 44 | 720 09 |
| | 5 | 70 | 18 | 2 - 18 | 10 | M48 x 1.5 | 80 | 97 | 19 | 6 | 34 | 39 | 44 | 720 10 |
| 4 | 5 | 90 | 24 | 3 - 24 | 15 | M48 x 1.5 | 104 | 97 | 19 | 6 | 39 | 49 | 59 | 720 11 |
| | 6 | 90 | 24 | 3 - 24 | 15 | M70 x 1.5 | 104 | 134 | 20 | 6 | 39 | 49 | 59 | 720 12 |
| 5 | 6 | 132 | 35 | 3 - 35 | 20 | M70 x 1.5 | 135 | 134 | 20 | 6 | 69 | 84 | 99 | 720 13 |
| 55 | 6 | 182 | 35 | 3 - 35 | 20 | M70 x 1.5 | 140 | 134 | 20 | 6 | 110 | 125 | 140 | 720 15 |
| 6 | 6 | 212 | 35 | 3 - 35 | 20 | M70 x 1.5 | 140 | 134 | 20 | 6 | 140 | 155 | 170 | 720 14 |

- Face driver with cylindrical shank upon request.
- All face drivers are supplied without drive pins. (drive pins see page 22 - 27)
- Types SB 01/0 are supplied with center body, all other types without center pin. (center pins see page 28)
- Reducing sleeves for face drivers see page 76 - 77.

Type series SB with MK retainer is embedded directly in the machine spindle and removed by means of an extracting nut. Driving devices and center pins can be exchanged front view on the machine without any effort.

If necessary and depending on the tooling direction of the machine the face driver can be equipped optionally with drive pins for counter-clockwise tooling (SR/tooling direction M3), for

clockwise tooling (SL/tooling direction M4) or for both tooling directions (NV = bi-directional).

Apart from the clamping diameters listed in the table under D1, D2, D3 we also supply intermediate dimensions upon request. We also make extra-large center pins or mushroom centers appropriate to oversized centerings in workpieces. (see page 30)

Face Drivers FFB / FFBH



with drive pins and fixed center pin for high true run accuracy

The entire surface of the workpiece can be completely machined with one single clamping and with a maximum of torque transmission. NEIDLEIN face drivers are mechanical clamping systems, suitable **for turning and hard turning** likewise.

Face drivers of type FFB/FFBH are power-operated on the side of the machine spindle as well as the side of the tailstock. The workpieces are clamped centrally by the fixed center pin. This operation results in high true run-out accuracy.

Drive pins of type FFBH are hydraulically activated and compensated, thus achieving excellent true run-out accuracy.

Type FFB with flange retainer

Type FFB is mounted onto the machine spindle nose using flange-adapter, adjustable for true run-out.



Type FFBH with flange retainer

Type FFBH is mounted onto the machine spindle nose using flange-adapter adjustable for true run-out.



NEIDLEIN face drivers FFB / FFBH with fixed center pin ensure:

- maximum of torque transmission, thus achieving a high rate of metal removing
- datum-point location in the center of the workpiece ensures constant measures of length
- extended service life of drive pins and cutting tools due to vibration-free running
- run-out deviation max.: 0.002 - 0.01 mm
- fixed clamping location
- compensating driving devices/ideal clamping of the workpiece
- easy handling

Clamping principle

The center pin located on the side of the tailstock pushes the workpiece against the fixed center pin of the face driver. The motion of the drive pins against the surface of the workpiece is initiated by the clamping cylinder mounted into the machine. The drive pins are "floatingly" suspended, thus compensating irregularities with regard to possible unevenness of the surface of workpieces. The datum-point of workpieces on the machines is determined by the size of the center hole. The entire surface of the workpiece can now be tooled in one single clamping.

See page 20-21 with data for achievable removal of material and the thrust requested. The appropriate standard drive pins and center pins can be found on page 22-27 and page 29.

We will be glad to design clamping devices suitable for your workpieces.

Type FFB / FFBH with flange retainer

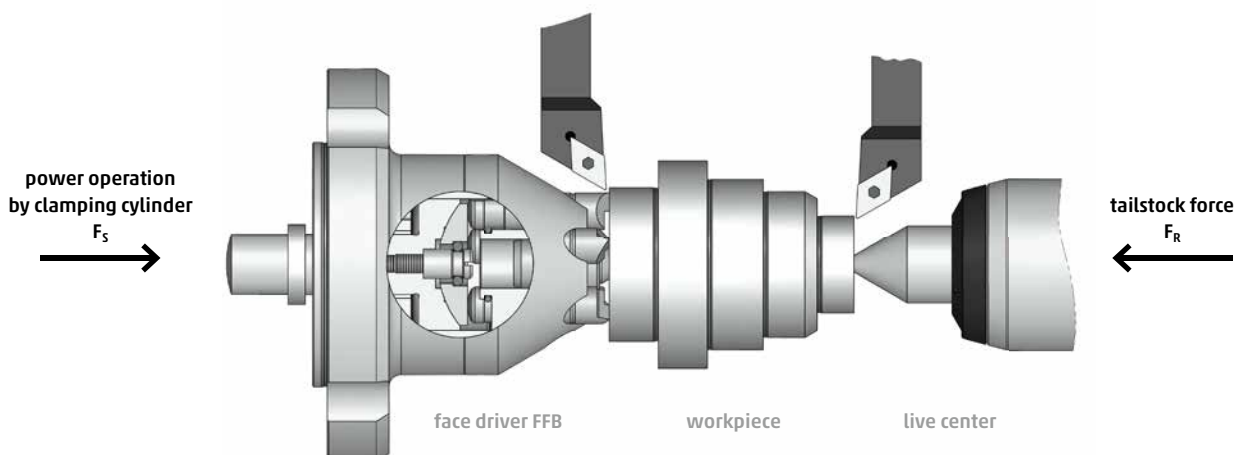

Technical data – type FFB face drivers

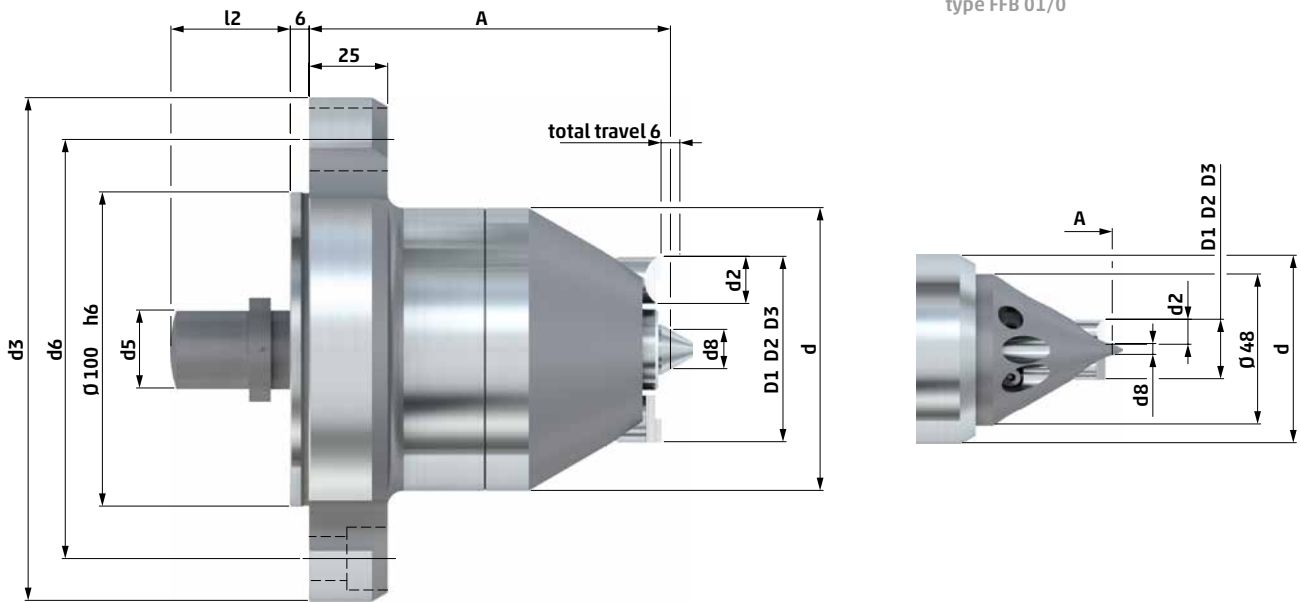

| type FFB | d | center Ø | d2 | d3 | d5 | d6 | d8 | A | l2 | drive pin | fastening screw type | pcs | clamping Ø | | | cat. no. |
|-------------|-----|----------|----|-----|----|-------|------|-----|----|-----------|-------------------------|-----|------------|-----|-----|---------------|
| | | | | | | | | | | | | | D1 | D2 | D3 | |
| 01 | 60 | 1 - 5 | 6 | 160 | 18 | 133.4 | 3.5 | 115 | 38 | 3 | M12 | 3 | 8 | 11 | 17 | 731 01 |
| 0 | 60 | 1 - 3 | 8 | 160 | 18 | 133.4 | 3 | 115 | 38 | 3 | M12 | 3 | 6 | 11 | 19 | 731 12 |
| 11 | 42 | 2 - 6.5 | 6 | 160 | 12 | 133.4 | 4.25 | 115 | 38 | 3 | M12 | 3 | 11 | 14 | 20 | 731 11 |
| 1 | 48 | 4 - 8.5 | 8 | 160 | 18 | 133.4 | 6.25 | 115 | 38 | 3 | M12 | 3 | 13 | 18 | 26 | 731 02 |
| 2 | 70 | 4 - 9 | 10 | 160 | 22 | 133.4 | 6.5 | 115 | 38 | 3 | M12 | 3 | 26 | 31 | 36 | 731 03 |
| 3 | 70 | 6 - 11 | 10 | 160 | 22 | 133.4 | 8.5 | 115 | 38 | 3 | M12 | 3 | 34 | 39 | 44 | 731 04 |
| 35 | 80 | 4 - 9 | 15 | 160 | 22 | 133.4 | 6.5 | 115 | 38 | 3 | M12 | 3 | 29 | 39 | 49 | 731 13 |
| 4 | 90 | 10 - 15 | 15 | 160 | 25 | 133.4 | 12.5 | 115 | 38 | 5 | M12 | 3 | 39 | 49 | 59 | 731 05 |
| 45 | 100 | 10 - 15 | 15 | 160 | 25 | 133.4 | 12.5 | 115 | 54 | 5 | M12 | 3 | 49 | 59 | 69 | 731 06 |
| 5 | 132 | 10 - 15 | 20 | 160 | 25 | 133.4 | 12.5 | 115 | 54 | 5 | M12 | 3 | 69 | 84 | 99 | 731 07 |
| 55 | 182 | 10 - 15 | 20 | 220 | 40 | 171.4 | 12.5 | 155 | 54 | 5 | M16 | 3 | 110 | 125 | 140 | 731 08 |
| 6 | 220 | 10 - 15 | 20 | 250 | 40 | 210 | 12.5 | 171 | 54 | 5 | M20 | 3 | 140 | 155 | 170 | 731 09 |

- All face drivers are supplied without drive pins. (drive pins see page 22 - 27)
- Types FFB 01/0 are supplied with center body, all other types without center pin. (center pin see page 29)
- The diameter d8 refers to the standard center pins. (see page 29)
- Further center pins for other center holes upon request. (see page 30)
- Mounting elements for face drivers see page 68 - 73.

It is the purpose of an adjustable flange-adapter to provide stable connection to the machine spindle. We supply these flange adapters for various sizes of spindle noses in standard size (DIN ISO 702-1/DIN 55028) or for spindle noses specific to machine-tool manufacturer. Thus face drivers of type FFB can be used all-purpose on different machines. Driving devices and center pins can be exchanged front view on the machine without any effort.

Upon request and depending on the tooling direction of the machine, the face driver can be equipped optionally with drive pins for counter-clockwise tooling (SR/tooling direction M3), for clockwise tooling (SL/tooling direction M4) or for both tooling directions (NV = bi-directional).

Apart from the clamping diameters enlisted in the table under D1, D2, D3 we can also supply intermediate dimensions upon request. We can as well make extra-large center pins or mushroom centers appropriate to oversized centerings in workpieces. (see page 30)

Technical data – type FFBH face drivers

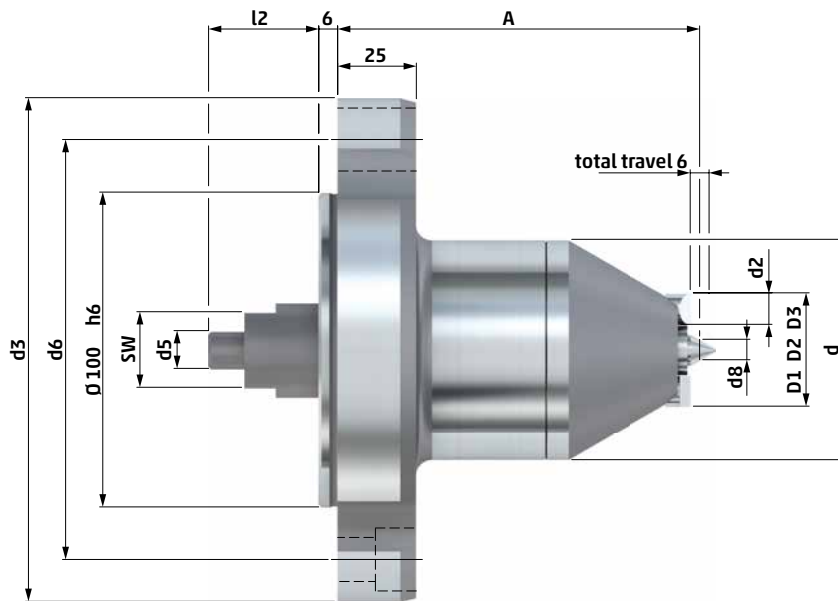

| type | d | center Ø | d2 | d3 | SW | d5 | d6 | d8 | A | l2 | drive pin | fastening screw | | | cat. no. | | |
|-----------|-----|----------|----|-----|----|----|-------|------|-----|----|-----------|-----------------|-----|------------|----------|----|---------------|
| | | | | | | | | | | | | type | pcs | clamping Ø | | | |
| FFBH | | | | | | | | | | | | | D1 | D2 | D3 | | |
| 1 | 70 | 4 - 8.5 | 8 | 160 | 24 | 12 | 133.4 | 6.25 | 115 | 35 | 3 | M12 | 3 | 13 | 18 | 26 | 631 02 |
| 2 | 70 | 4 - 9 | 10 | 160 | 24 | 12 | 133.4 | 6.5 | 115 | 35 | 3 | M12 | 3 | 26 | 31 | 36 | 631 03 |
| 3 | 70 | 6 - 11 | 10 | 160 | 24 | 12 | 133.4 | 8.5 | 115 | 35 | 3 | M12 | 3 | 34 | 39 | 44 | 631 04 |
| 4 | 90 | 10 - 15 | 15 | 160 | 34 | 12 | 133.4 | 12.5 | 132 | 35 | 5 | M12 | 3 | 39 | 49 | 59 | 631 06 |
| 45 | 100 | 10 - 15 | 15 | 160 | 34 | 12 | 133.4 | 12.5 | 132 | 35 | 5 | M12 | 3 | 49 | 59 | 69 | 631 07 |
| 5 | 132 | 10 - 15 | 20 | 160 | 34 | 12 | 133.4 | 12.5 | 149 | 35 | 5 | M12 | 3 | 69 | 84 | 99 | 631 08 |

- All face drivers are supplied without drive pins and without center pins. (changeable parts see page 22 - 27 and page 29)
- The diameter d8 refers to the standard center pins. (see page 28)
- Further center pins for other center holes upon request. (see page 30)
- Mounting elements for face drivers see page 68 - 73.

Technical data – type FFBH hydraulic unit

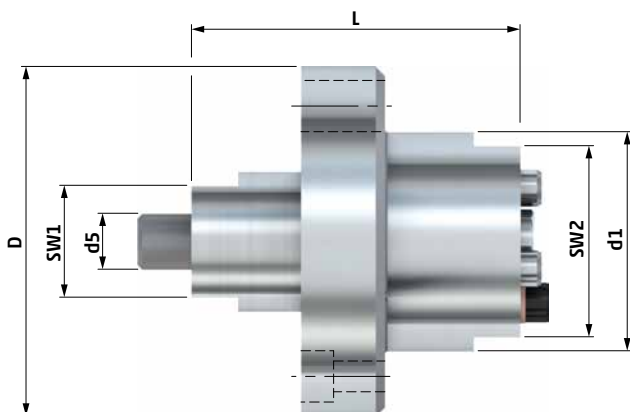

| type | SW1 | d5 | L | d1 | SW2 | D | cat. no. |
|-----------|-----|----|------|----|-----|-----|------------------|
| FFBH | | | | | | | |
| 1 | 24 | 12 | 70,5 | 47 | 41 | 75 | 631 02 HE |
| 2 | 24 | 12 | 70,5 | 47 | 41 | 75 | |
| 3 | 24 | 12 | 70,5 | 47 | 41 | 75 | |
| 4 | 34 | 12 | 70,5 | 65 | 59 | 93 | 631 06 HE |
| 45 | 34 | 12 | 70,5 | 65 | 59 | 93 | |
| 5 | 34 | 12 | 70,5 | 87 | 81 | 131 | 631 08 HE |

The general explanatory notes for this face driver FFBH can be obtained from the sheet "technical data – type FFB". For safe and smooth operation of face driver we recommend exchange of hydraulic unit after 1500 operating hours.

Furthermore, we offer the option for professional maintenance of the exchanged hydraulic units in our production plant.



Drive Pins FSB / SB / FFB · Chisel SL / SR / NV

for torque transmission onto the workpiece
for soft / green tooling

Type **FSB / SB / FFB** · chisel SL / SR / NV



SR



SL

SR

NV

view from tailstock onto the face driver

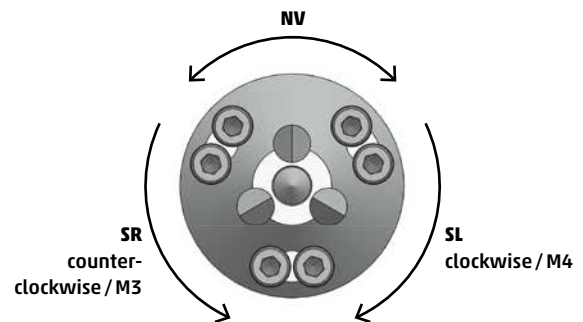

NV

SR

counter-
clockwise / M3

SL

clockwise / M4

Technical data – type **FSB / SB / FFB** · chisel SL / SR / NV

types 01 and 11 with chisel SL and SR are double chiselled

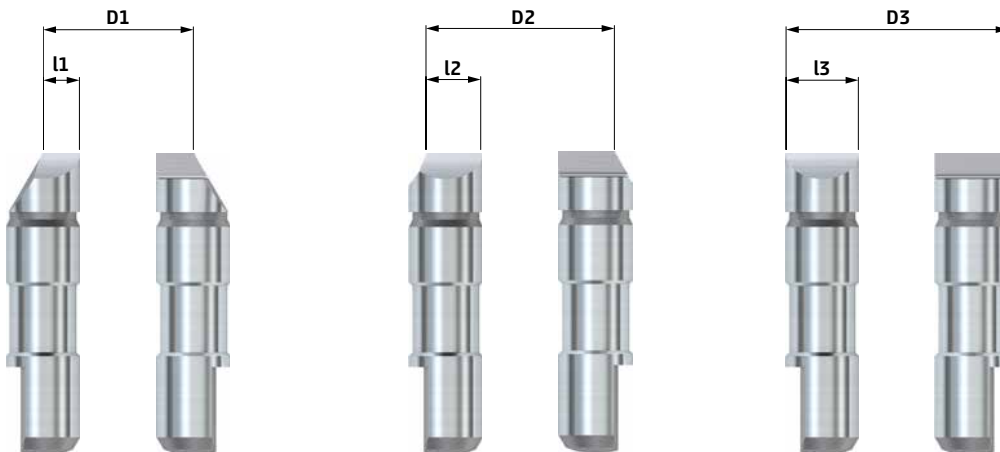

TYPE CHISEL SL
for tooling
direction M4

TYPE CHISEL SR
for tooling
direction M3

TYPE CHISEL NV
for tooling
direction M4 and M3

| for type FSB/SB/FFB | clamping Ø | | | chisel length | | | cat. no. | cat. no. | cat. no. |
|------------------------|------------|-----|-----|---------------|-----|-----|----------------|----------------|----------------|
| | D1 | D2 | D3 | l1 | l2 | l3 | | | |
| 01 | 8 | | | 1.5 | | | 736 104 | 736 101 | 736 107 |
| | | 11 | | | 3 | | 736 105 | 736 102 | 736 108 |
| | | | 17 | | | 6 | 736 106 | 736 103 | 736 109 |
| 0 | 6 | | | 1.5 | | | 736 04 | 736 01 | 736 07 |
| | | 11 | | | 4 | | 736 05 | 736 02 | 736 08 |
| | | | 19 | | | 8 | 736 06 | 736 03 | 736 09 |
| 1 | 13 | | | 1.5 | | | 736 13 | 736 10 | 736 16 |
| | | 18 | | | 4 | | 736 14 | 736 11 | 736 17 |
| | | | 26 | | | 8 | 736 15 | 736 12 | 736 18 |
| 11 | 11 | | | 1.5 | | | 736 76 | 736 73 | 736 79 |
| | | 14 | | | 3 | | 736 77 | 736 74 | 736 80 |
| | | | 20 | | | 6 | 736 78 | 736 75 | 736 81 |
| 2 | 26 | | | 5 | | | 736 22 | 736 19 | 736 25 |
| | | 31 | | | 7.5 | | 736 23 | 736 20 | 736 26 |
| | | | 36 | | | 10 | 736 24 | 736 21 | 736 27 |
| 3 | 34 | | | 5 | | | 736 31 | 736 28 | 736 34 |
| | | 39 | | | 7.5 | | 736 32 | 736 29 | 736 35 |
| | | | 44 | | | 10 | 736 33 | 736 30 | 736 36 |
| 35 | 29 | | | 5 | | | 736 85 | 736 82 | 736 88 |
| | | 39 | | | 5 | | 736 86 | 736 83 | 736 89 |
| | | | 49 | | | 5 | 736 87 | 736 84 | 736 90 |
| 4 | 39 | | | 5 | | | 736 40 | 736 37 | 736 43 |
| | | 49 | | | 7.5 | | 736 41 | 736 38 | 736 44 |
| | | | 59 | | | 7.5 | 736 42 | 736 39 | 736 45 |
| 45 | 49 | | | 5 | | | 736 94 | 736 91 | 736 97 |
| | | 59 | | | 7.5 | | 736 95 | 736 92 | 736 98 |
| | | | 69 | | | 7.5 | 736 96 | 736 93 | 736 99 |
| 5 | 69 | | | 5 | | | 73649 | 736 46 | 736 52 |
| | | 84 | | | 10 | | 73650 | 736 47 | 736 53 |
| | | | 99 | | | 10 | 73651 | 736 48 | 736 54 |
| 55 | 110 | | | 5 | | | 73658 | 736 55 | 736 61 |
| | | 125 | | | 10 | | 73659 | 736 56 | 736 62 |
| | | | 140 | | | 10 | 73660 | 736 57 | 736 63 |
| 6 | 140 | | | 5 | | | 73667 | 736 64 | 736 70 |
| | | 155 | | | 10 | | 73668 | 736 65 | 736 71 |
| | | | 170 | | | 10 | 73669 | 736 66 | 736 72 |
| 7 | 180 | | | 5 | | | 736 114 | 736 111 | 736 117 |
| | | 195 | | | 15 | | 736 115 | 736 112 | 736 118 |
| | | | 210 | | | 20 | 736 116 | 736 113 | 736 119 |
| 75 | 230 | | | 5 | | | 736 344 | 736 341 | 736 347 |
| | | 245 | | | 15 | | 736 345 | 736 342 | 736 348 |
| | | | 260 | | | 20 | 736 346 | 736 343 | 736 349 |
| 8 | 270 | | | 10 | | | 736 373 | 736 370 | 736 376 |
| | | 290 | | | 20 | | 736 374 | 736 371 | 736 377 |
| | | | 310 | | | 30 | 736 375 | 736 372 | 736 378 |
| 85 | 320 | | | 10 | | | 736 364 | 736 361 | 736 367 |
| | | 340 | | | 20 | | 736 365 | 736 362 | 736 368 |
| | | | 360 | | | 30 | 736 366 | 736 363 | 736 369 |

■ Further clamping Ø of drive pins upon request.



Drive Pins FSB / SB / FFB · KV-HS

**cross serrated and coated for hard turning operation
for torque transmission onto the workpiece
for hard tooling**

Type FSB / SB / FFB · KV-HS



Technical data – type FSB / SB / FFB · KV-HS

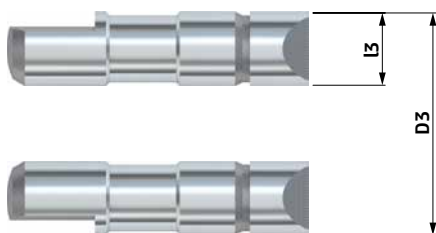
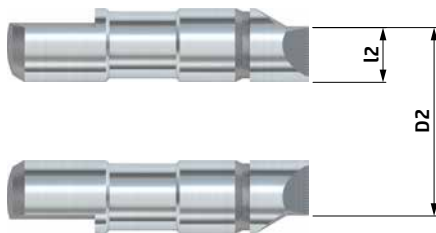
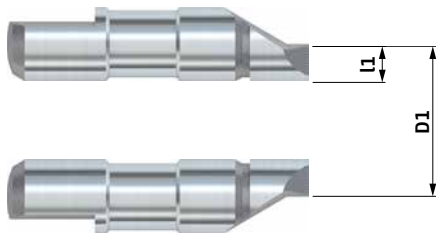

| for type FSB/SB/FFB | clamping Ø | | | chisel length | | | cat. no. |
|------------------------|------------|----|-----|---------------|------|----|----------------|
| | D1 | D2 | D3 | l1 | l2 | l3 | |
| 01 | 8 | | | 1.5 | | | 736 200 |
| | 11 | | | | 3 | | 736 201 |
| | | | 17 | | | 6 | 736 202 |
| 0 | 6 | | | 1.5 | | | 736 203 |
| | 11 | | | | 4 | | 736 204 |
| | | | 19 | | | 8 | 736 205 |
| 1 | 13 | | | 1.5 | | | 736 209 |
| | 18 | | | | 4 | | 736 210 |
| | | | 26 | | | 8 | 736 211 |
| 11 | 11 | | | 1.5 | | | 736 206 |
| | 14 | | | | 3 | | 736 207 |
| | | | 20 | | | 6 | 736 208 |
| 2 | 26 | | | 5 | | | 736 212 |
| | 31 | | | | 7.5 | | 736 213 |
| | | | 36 | | | 10 | 736 214 |
| 3 | 34 | | | 5 | | | 736 215 |
| | 39 | | | | 7.5 | | 736 216 |
| | | | 44 | | | 10 | 736 217 |
| 35 | 29 | | | 5 | | | 736 218 |
| | 39 | | | | 10 | | 736 219 |
| | | | 49 | | | 15 | 736 220 |
| 4 | 39 | | | 5 | | | 736 221 |
| | 49 | | | | 10 | | 736 222 |
| | | | 59 | | | 15 | 736 223 |
| 45 | 49 | | | 5 | | | 736 224 |
| | 59 | | | | 10 | | 736 225 |
| | | | 69 | | | 15 | 736 226 |
| 5 | 69 | | | 5 | | | 736 227 |
| | 84 | | | | 12.5 | | 736 228 |
| | | | 99 | | | 20 | 736 229 |
| 55 | 110 | | | 5 | | | 736 230 |
| | 125 | | | | 12.5 | | 736 231 |
| | | | 140 | | | 20 | 736 232 |
| 6 | 140 | | | 5 | | | 736 233 |
| | 155 | | | | 12.5 | | 736 234 |
| | | | 170 | | | 20 | 736 235 |

■ Further clamping Ø of drive pins upon request.



Drive Pins FSB / SB / FFB · FV Diamond

serrated and diamond embedded
for torque transmission onto the workpiece
for hard tooling

for higher friction coefficient and higher tool life of drive pin

Type FSB / SB / FFB · FV diamond

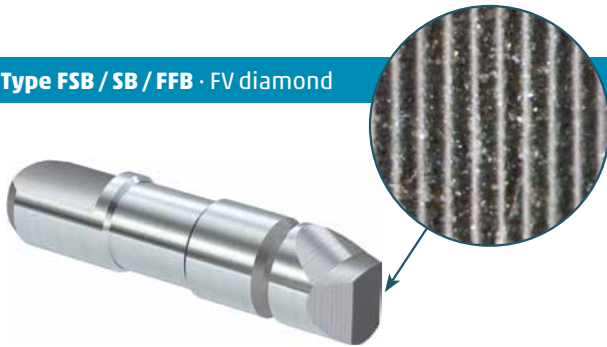

Technical data - type FSB / SB / FFB · FV diamond

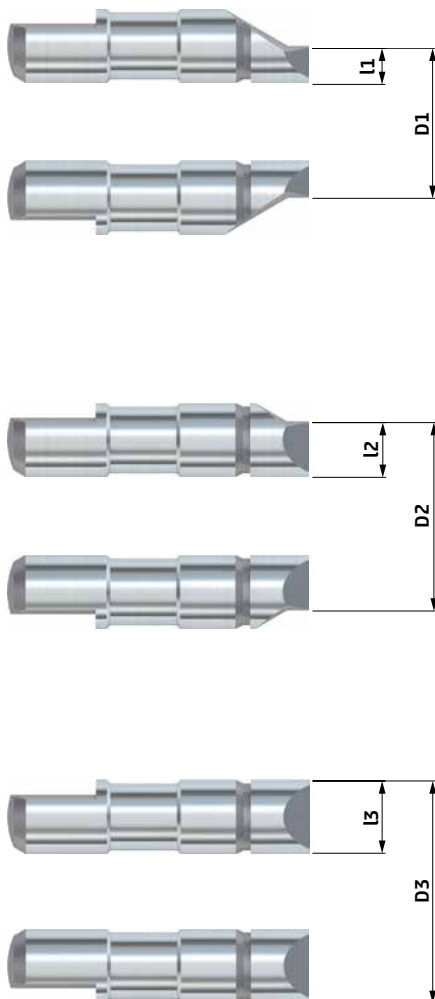

| for type FSB/SB/FFB | clamping Ø | | | chisel length | | | cat. no. |
|------------------------|------------|----|-----|---------------|------|----|----------------|
| | D1 | D2 | D3 | l1 | l2 | l3 | |
| 01 | 8 | | | 1.5 | | | 736 400 |
| | 11 | | | | 3 | | 736 401 |
| | | | 17 | | | 6 | 736 402 |
| 0 | 6 | | | 1.5 | | | 736 403 |
| | 11 | | | | 4 | | 736 404 |
| | | | 19 | | | 8 | 736 405 |
| 1 | 13 | | | 1.5 | | | 736 409 |
| | 18 | | | | 4 | | 736 410 |
| | | | 26 | | | 8 | 736 411 |
| 11 | 11 | | | 1.5 | | | 736 406 |
| | 14 | | | | 3 | | 736 407 |
| | | | 20 | | | 6 | 736 408 |
| 2 | 26 | | | 5 | | | 736 412 |
| | 31 | | | | 7.5 | | 736 413 |
| | | | 36 | | | 10 | 736 414 |
| 3 | 34 | | | 5 | | | 736 415 |
| | 39 | | | | 7.5 | | 736 416 |
| | | | 44 | | | 10 | 736 417 |
| 35 | 29 | | | 5 | | | 736 418 |
| | 39 | | | | 10 | | 736 419 |
| | | | 49 | | | 15 | 736 420 |
| 4 | 39 | | | 5 | | | 736 421 |
| | 49 | | | | 10 | | 736 422 |
| | | | 59 | | | 15 | 736 423 |
| 45 | 49 | | | 5 | | | 736 424 |
| | 59 | | | | 10 | | 736 425 |
| | | | 69 | | | 15 | 736 426 |
| 5 | 69 | | | 5 | | | 736 427 |
| | 84 | | | | 12.5 | | 736 428 |
| | | | 99 | | | 20 | 736 429 |
| 55 | 110 | | | 5 | | | 736 430 |
| | 125 | | | | 12.5 | | 736 431 |
| | | | 140 | | | 20 | 736 432 |
| 6 | 140 | | | 5 | | | 736 433 |
| | 155 | | | | 12.5 | | 736 434 |
| | | | 170 | | | 20 | 736 435 |

■ Further clamping Ø of drive pins upon request.



Drive Pins FSB / SB / FFB · Chisel Carbide

full carbide / carbide inserts
for torque transmission onto the workpiece
for tooling of high-tensile-strength materials

Type FSB / SB / FFB · chisel carbide

model B / SR



MODEL A



MODEL B

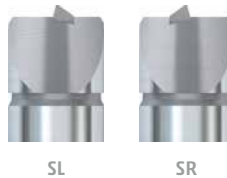

Technical data – type FSB / SB / FFB · chisel carbide

type 01 - 3 made of full carbide, model A

type 35 - 6 with carbide inserts, model B

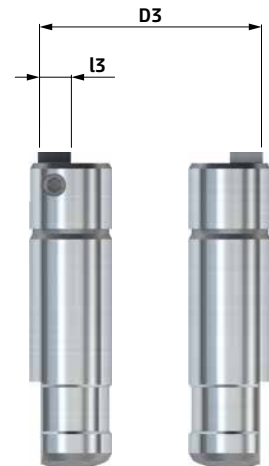

MODEL A**TYPE CHISEL SL**for tooling
direction M4**TYPE CHISEL SR**for tooling
direction M3**TYPE CHISEL NV**for tooling
direction M4 and M3

| for type FSB / SB / FFB | clamping Ø D3 | length l3 | cat. no. | cat. no. | cat. no. |
|----------------------------|------------------|--------------|----------------|----------------|----------------|
| 01 | 17 | 6 | 736 500 | 736 518 | 736 536 |
| 0 | 19 | 8 | 736 501 | 736 519 | 736 537 |
| 1 | 26 | 8 | 736 502 | 736 520 | 736 538 |
| 11 | 20 | 6 | 736 503 | 736 521 | 736 539 |
| 2 | 36 | 10 | 736 504 | 736 522 | 736 540 |
| 3 | 44 | 10 | 736 505 | 736 523 | 736 541 |

MODEL B

| for type FSB / SB / FFB | clamping Ø | | length l3 | cat. no. | cat. no. |
|----------------------------|------------|-----|--------------|----------------|----------------|
| | D1 | D3 | | | |
| 35 | 34 | | 6 | 736 506 | 736 524 |
| | | 46 | 6 | 736 507 | 736 525 |
| 4 | 44 | | 6 | 736 508 | 736 526 |
| | | 56 | 6 | 736 509 | 736 527 |
| 45 | 54 | | 6 | 736 510 | 736 528 |
| | | 66 | 6 | 736 511 | 736 529 |
| 5 | 75 | | 6 | 736 512 | 736 530 |
| | | 95 | 6 | 736 513 | 736 531 |
| 55 | 116 | | 6 | 736 514 | 736 532 |
| | | 136 | 6 | 736 515 | 736 533 |
| 6 | 146 | | 6 | 736 516 | 736 534 |
| | | 166 | 6 | 736 517 | 736 535 |

- Drive Pins are supplied with carbide insert.
- Further clamping-Ø of drive pins upon request.

Changeable inserts for type 35 - 6, model B

| changeable parts | cat. no. |
|--|----------------|
| carbide insert | 736 550 |
| set screw for fastening of carbide insert | 736 551 |



Center Pins FSB / SB

for face drivers FSB / SB with movable center pin

Type FSB / SB · center pin



center body type FSB / SB 01 / 0



Technical data - type FSB / SB · center pin

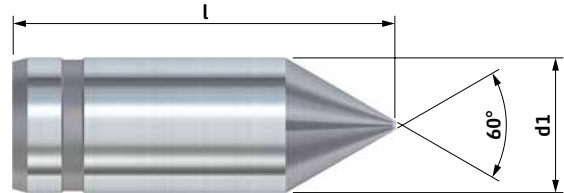

center body type FSB / SB 01 / 0

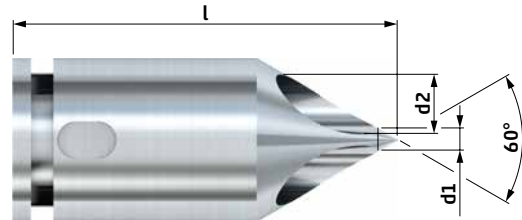

| for type FSB / SB | d1 | center Ø | d2 | l | cat. no. |
|----------------------|----|----------|----|-----|----------------|
| 01 | 5 | 0 - 5 | 6 | 52 | 735 101 |
| 0 | 3 | 0 - 3 | 8 | 52 | 735 01 |
| 11 | 6 | 0 - 6 | - | 53 | 735 11 |
| 1 | 8 | 0 - 8 | - | 53 | 735 02 |
| 2 | 14 | 2 - 14 | - | 47 | 735 03 |
| 3 | 18 | 2 - 18 | - | 51 | 735 04 |
| 35 | 14 | 2 - 14 | - | 47 | 735 09 |
| 4 | 24 | 3 - 24 | - | 70 | 735 05 |
| 45 | 28 | 3 - 28 | - | 74 | 735 10 |
| 5 | 35 | 6 - 35 | - | 96 | 735 06 |
| 55 | 35 | 6 - 35 | - | 96 | 735 08 |
| 6 | 35 | 6 - 35 | - | 96 | 735 07 |
| 7 | 50 | 25 - 48 | - | 100 | 735 301 |
| 75 | 50 | 25 - 48 | - | 100 | 735 401 |
| 8 | 80 | 30 - 76 | - | 135 | 735 601 |
| 85 | 80 | 30 - 76 | - | 135 | 735 501 |

■ Further center pins for other center holes upon request.

Center Pins FFB / FFBH

for face drivers FFB / FFBH with fixed center pin

Type FFB / FFBH · tool steel or carbide

Technical data - type FFB / FFBH · tool steel or carbide



with carbide insert

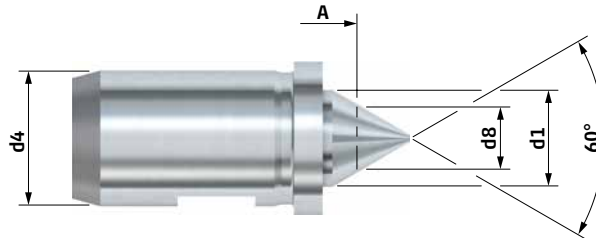

A overhang dimension of face driver to centre d8 (see page 18-19)

center body type FSB / SB 01 / 0

center body type FSB / SB 01 / 0

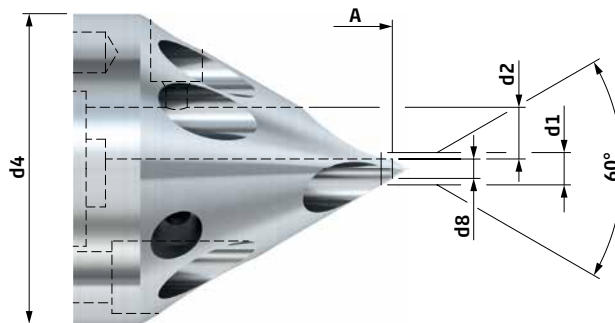

TYPE
TOOL STEEL

TYPE
CARBIDE

| for type FFB / FFBH | d1 | d2 | d4 | center Ø | d8 | cat. no. |
|------------------------|-----|----|----|----------|------|----------------|
| 01 | 5 | 6 | 48 | 1-5 | 3.5 | 734 01 |
| 0 | 3 | 8 | 48 | 1-3 | 3 | 734 101 |
| 11 | 7.8 | - | 6 | 2-6.5 | 4.25 | 734 11 |
| 1 | 9.8 | - | 8 | 4-8.5 | 6.25 | 734 02 |
| 2 | 10 | - | 14 | 4-9 | 6.5 | 734 03 |
| 3 | 12 | - | 18 | 6-11 | 8.5 | 734 04 |
| 35 | 10 | - | 14 | 4-9 | 6.5 | 734 12 |
| 4 | 16 | - | 20 | 10-15 | 12.5 | 734 05 |
| 45 | 16 | - | 28 | 10-15 | 12.5 | 734 06 |
| 5 | 16 | - | 35 | 10-15 | 12.5 | 734 07 |
| 55 | 16 | - | 35 | 10-15 | 12.5 | 734 08 |
| 6 | 16 | - | 35 | 10-15 | 12.5 | 734 09 |

| cat. no. |
|---------------|
| 734 43 |
| 734 44 |
| 734 33 |
| 734 34 |
| 734 35 |
| 734 36 |
| 734 37 |
| 734 38 |
| 734 39 |
| 73440 |
| 734 41 |
| 734 42 |

- Further center pins for other center holes upon request.
- Center pins of type FFB / FFBH 01 / 0 (type carbide) are just carbide coated on the 60° centering.



Pipe Drivers NDG / AND

The entire outside surface of a tubular workpiece can be tooled with one single clamping and high torque transmission.

By means of a pipe driver, large clamping areas can be covered.

Type NDG pipe driver



Clamping principle

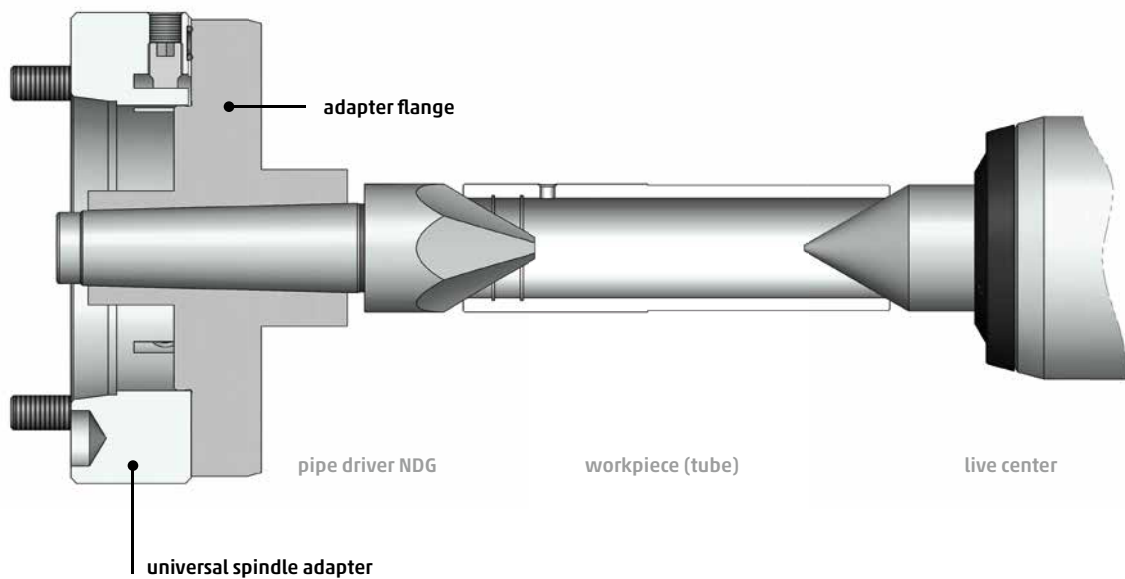

NEIDLEIN pipe drivers NDG and AND ensure:

- high torque transmission, thus achieving a high rate of metal removing
- extended service life of driving chisels
- large clamping area of tubular workpieces
2 - 155 mm bore-diameter
- finishing of outer surface by clamping
» saving of time
- easy handling

Technical data - type NDG pipe driver

| type NDG | morse taper | D | d1 | L | L1 | L2 | L3 | a | chisel PCS | for bore-Ø from | to | cat. no. |
|----------|-------------|----|----|-----|----|----|-----|-----|------------|-----------------|----|----------|
| 0/15 | 2 | 18 | 0 | 100 | 32 | 4 | 68 | 60° | 6 | 2 | 17 | 750 01 |
| 0/30 | 3 | 31 | 0 | 135 | 50 | 5 | 85 | 60° | 6 | 2 | 30 | 750 02 |
| 10/40 | 3 | 45 | 8 | 145 | 60 | 5 | 85 | 60° | 6 | 9 | 43 | 750 03 |
| 20/60 | 3 | 63 | 18 | 147 | 62 | 5 | 85 | 60° | 8 | 19 | 60 | 750 04 |
| 10/40 | 4 | 45 | 8 | 168 | 60 | 6 | 108 | 60° | 6 | 9 | 43 | 750 05 |
| 20/60 | 4 | 63 | 18 | 170 | 62 | 6 | 108 | 60° | 8 | 19 | 60 | 750 06 |

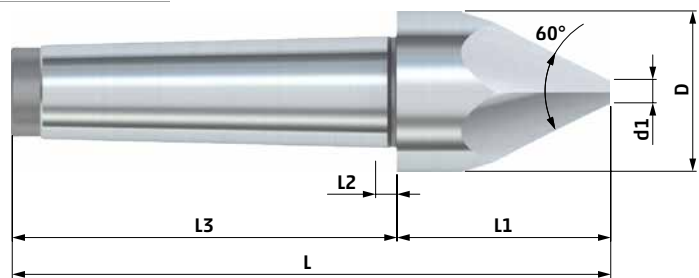

Technical data - type NDG drive cone exchangeable

| type NDG | D | d1 | d2 | L | L1 | a | chisel PCS | for bore-Ø from | to | cat. no. |
|----------|-----|------|----|----|----|-----|------------|-----------------|-----|----------|
| 35/90 | 93 | 32.8 | 35 | 70 | 46 | 60° | 10 | 33 | 90 | 751 01 |
| 90/155 | 158 | 88 | 35 | 75 | 46 | 60° | 10 | 88 | 155 | 751 02 |

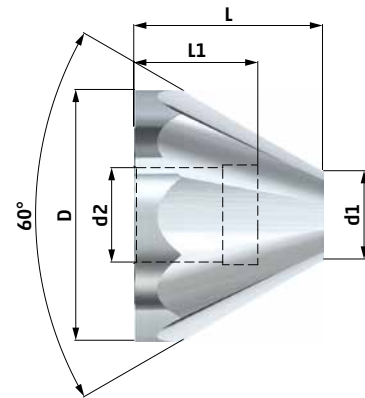

Technical data - type AND arbor

| type AND | morse taper | D | d2 | L1 | L2 | L3 | L4 | cat. no. |
|----------|-------------|------|----|----|----|----|-----|----------|
| 35/4 | 4 | 46 | 35 | 36 | 16 | 5 | 108 | 752 01 |
| 35/5 | 5 | 44.5 | 35 | 36 | 16 | 5 | 130 | 752 02 |
| 35/6 | 6 | 64 | 35 | 36 | 16 | 5 | 144 | 752 03 |

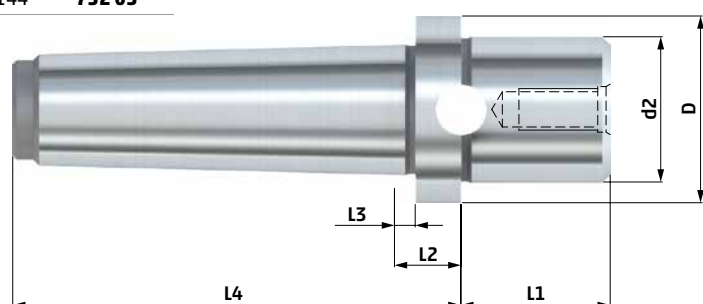



Face Drivers FFBR / FBSR

with drive pins and fixed center pin

The complete surface of both, hardened and soft workpieces, can be finish-ground with one single clamping.

Face drivers types FFBR/FBSR are power-operated on the side of the spindle. The workpieces are clamped centrally using a dead center pin, this way a high true running accuracy is achieved.

Type FFBR with flange retainer

There are two retainer designs for adapting the face drivers onto the machine spindle – either for adaption onto a flange adapter with 140 in diameter or for direct mounting onto a spindle nose DIN 702-1 size 6 (DIN 55026/28).



Type FBSR with morse taper retainer

Like face driver FFBR, but including morse taper shank and extracting nut. Adjustment true by using set screws inside shank for highest true running accuracy.



NEIDLEIN face drivers FFBR / FBSR ensure:

- datum-point located in the center of the workpiece
- run-out deviation max.: 0.002 - 0.003 mm
- compensating drive components
- retractable drive pins for secure loading and unloading of the workpiece
- adjustment true at face drivers for highest run-out requirements

Clamping principle

The center pin located on the side of the tailstock pushes the workpiece against the fixed center pin of the face driver. The motion of the drive pins against the surface of the workpiece is initiated by the clamping cylinder mounted into the machine. The drive pins are "floatingly" suspended, thus compensating

irregularities with regard to possible unevenness of the surface of workpieces. The datum-point of workpieces on the machines is determined by the size of the center hole. The entire surface of workpiece can now be tooled in one single clamping.

Typ FFBR mit Flanschaufnahme

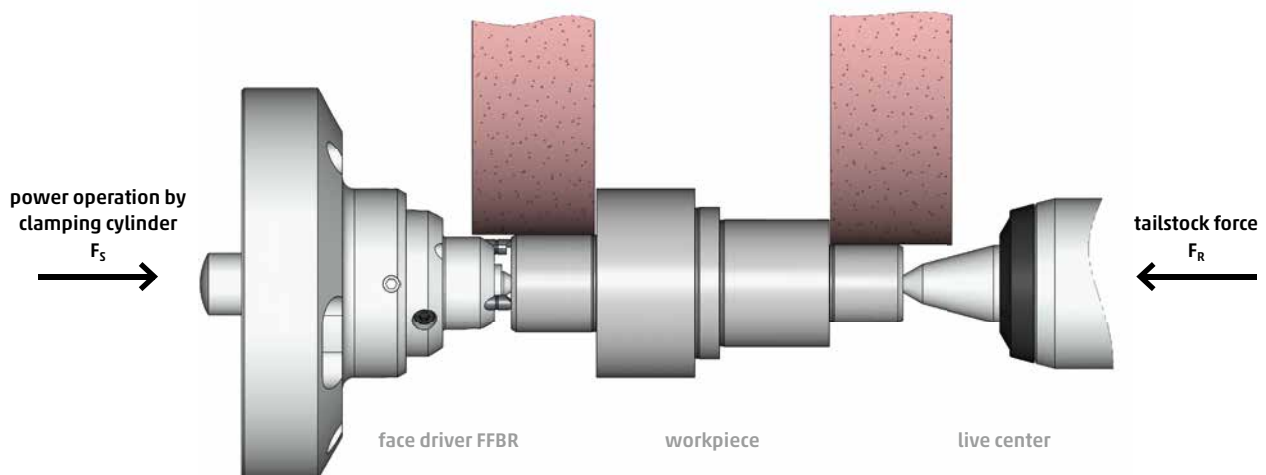

Technical data – type FFBR face driver

type cylindrical retainer $\varnothing 140$ mm
on flange adapter

type short taper retainer DIN 702-1 size 6
directly onto the machine spindle

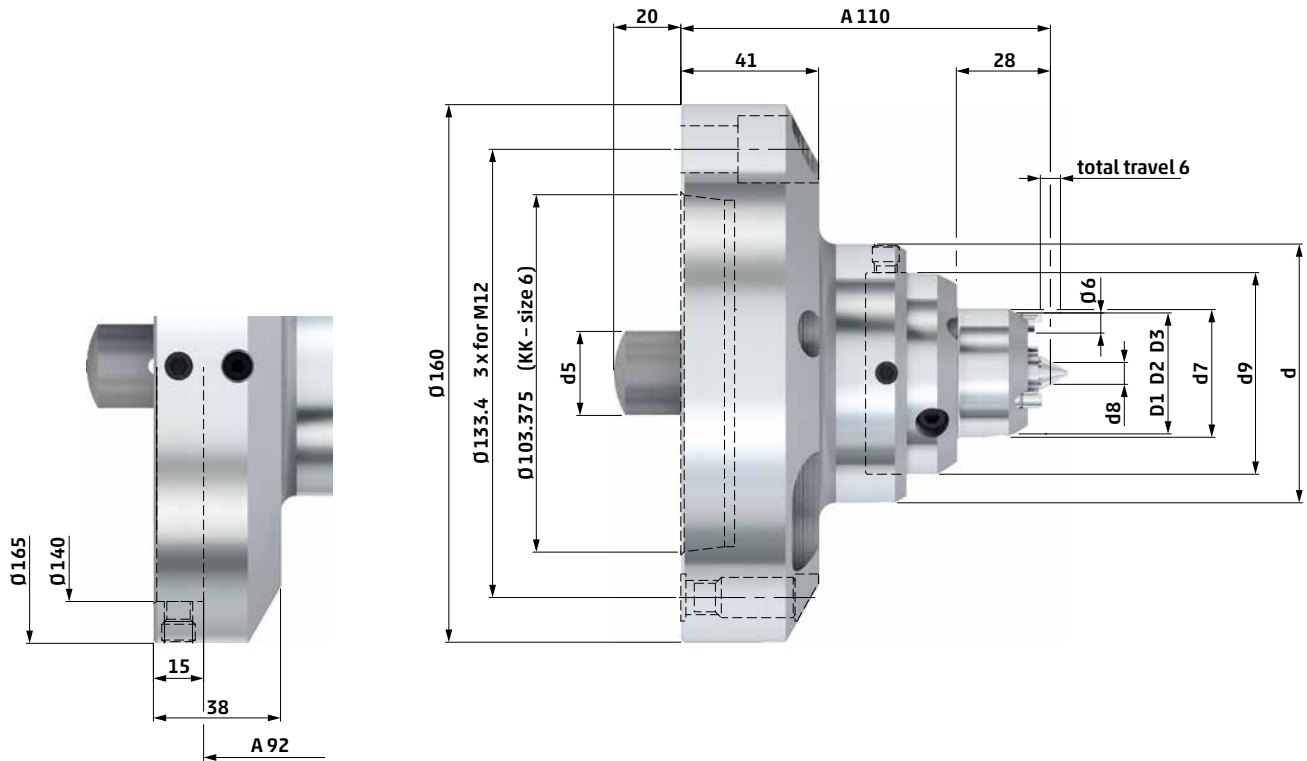
**TYPE CYLINDRICAL
RETAINER $\varnothing 140$ mm****TYPE SHORT TAPER
RETAINER SIZE 6**

| type FFBR | d | center \varnothing | d5 | d7 | d8 | d9 | clamping \varnothing | | | cat. no. |
|--------------|-----|----------------------|----|----|------|----|------------------------|----|----|---------------|
| | | | | | | | D1 | D2 | D3 | |
| 0 | 65 | 1 - 3 | 18 | 16 | 1.5 | 48 | 6 | 9 | 15 | 726 31 |
| 01 | 65 | 1 - 5 | 18 | 18 | 3 | 48 | 8 | 11 | 17 | 726 32 |
| 11 | 65 | 2 - 6.5 | 18 | 21 | 4.25 | 48 | 11 | 14 | 20 | 726 33 |
| 1 | 65 | 4 - 8.5 | 18 | 25 | 6.25 | 48 | 15 | 18 | 24 | 726 34 |
| 2 | 77 | 4 - 9 | 25 | 38 | 6.5 | 60 | 27 | 30 | 36 | 726 35 |
| 3 | 85 | 6 - 11 | 25 | 46 | 8.5 | 68 | 35 | 38 | 44 | 726 36 |
| 4 | 110 | 10 - 15 | 25 | 62 | 12.5 | 83 | 50 | 53 | 59 | 726 37 |

| cat. no. |
|---------------|
| 726 01 |
| 726 02 |
| 726 03 |
| 726 04 |
| 726 05 |
| 726 06 |
| 726 07 |

- Face drivers without changeable parts (types 0 / 01 include center body). Center pins, center bodies and drive pins see page 56 - 57.
- All face drivers for grinding are designed for 3 drive pins only.
- Diameter d8 refers to standard center pins. (see page 57)
- Further center pins for other center holes upon request.

Technical data – type FBSR face driver

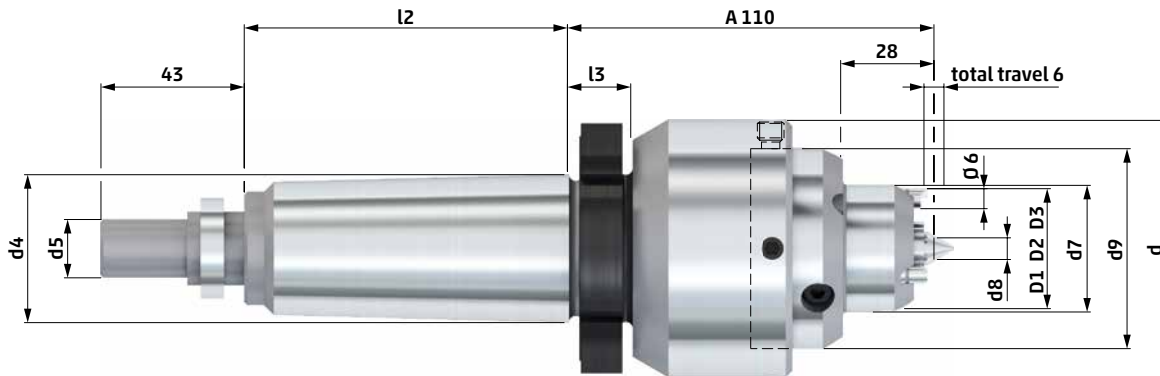

| type FBSR | MK | d | center Ø | d5 | d7 | d8 | d9 | L | l2 | l3 | clamping Ø | | | cat. no. |
|--------------|----|-----|----------|------|----|------|----|-----|----|----|------------|----|----|---------------|
| | | | | | | | | | | | D1 | D2 | D3 | |
| 0 | 4 | 65 | 1 - 3 | 11.5 | 16 | 1.5 | 48 | 183 | 73 | 16 | 6 | 9 | 15 | 726 51 |
| 01 | 4 | 65 | 1 - 5 | 11.5 | 18 | 3 | 48 | 183 | 73 | 16 | 8 | 11 | 17 | 726 52 |
| 11 | 4 | 65 | 2 - 6.5 | 11.5 | 21 | 4.25 | 48 | 183 | 73 | 16 | 11 | 14 | 20 | 726 53 |
| 1 | 4 | 65 | 4 - 8.5 | 11.5 | 25 | 6.25 | 48 | 183 | 73 | 16 | 15 | 18 | 24 | 726 54 |
| | 5 | 65 | 4 - 8.5 | 17.5 | 25 | 6.25 | 48 | 207 | 97 | 19 | 15 | 18 | 24 | 726 55 |
| 2 | 4 | 77 | 4 - 9 | 11.5 | 38 | 6.5 | 60 | 183 | 73 | 16 | 27 | 30 | 36 | 726 56 |
| | 5 | 77 | 4 - 9 | 17.5 | 38 | 6.5 | 60 | 207 | 97 | 19 | 27 | 30 | 36 | 726 57 |
| 3 | 4 | 85 | 6 - 11 | 11.5 | 46 | 8.5 | 68 | 183 | 73 | 16 | 35 | 38 | 44 | 726 58 |
| | 5 | 85 | 6 - 11 | 17.5 | 46 | 8.5 | 68 | 207 | 97 | 19 | 35 | 38 | 44 | 726 59 |
| 4 | 4 | 110 | 10 - 15 | 11.5 | 62 | 12.5 | 85 | 183 | 73 | 16 | 50 | 53 | 59 | 726 60 |
| | 5 | 110 | 10 - 15 | 17.5 | 62 | 12.5 | 85 | 207 | 97 | 19 | 50 | 53 | 59 | 726 61 |

- Face drivers without changeable parts (types 0 / 01 include center body). Center pins, center bodies and drive pins see page 56 - 57.
- All face drivers for grinding are designed for 3 drive pins only.
- Diameter d8 refers to standard center pins. (see page 57)
- Further center pins for other center holes upon request.



Drive Pins FFBR / FBSR · Chisel SR · Diamond

for torque transmission onto the workpiece by grinding soft and hardened workpieces

For soft workpieces we apply drive pins made of hardened HSS comprising a chisel. They are characterized by high wear-resistance as well as maximum torque transmission.

For hardened workpieces we apply drive pins that are diamond coated. They are characterized by a high friction-coefficient.

Type FFBR / FBSR · chisel SR · diamond



Technical data – type FFBR / FBSR · chisel SR · diamond

model A



model B



model C



view from tailstock
onto the face driver

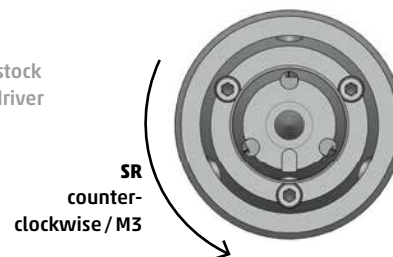

TYPE CHISEL SR

| for type | for clamping | model | l | cat. no. |
|--------------|--------------|-------|-----|----------------|
| FFBR FBSR | D1 | C | 1.5 | 736 651 |
| FFBR FBSR | D2 | B | 2 | 736 652 |
| FFBR FBSR | D3 | A | 2 | 736 653 |

TYPE DIAMOND COATING

| l | cat. no. |
|-----|----------------|
| 1.5 | 736 654 |
| 3 | 736 655 |
| 3 | 736 656 |

- Clamping diameter D1, D2, D3 see pages 54 - 55.
- Further clamping \varnothing of drive pins upon request.

Center Pins FFBR / FBSR

for face drivers FFBR / FBSR with fixed center pin

For maximum stability and run-out requirements the center pins are produced with narrow tolerances and are fixed safely via set screw and plane surface inside the face driver.

Due to the accurate assembly between center pin and head of face driver we ensure highly accurate replacement.

For a large batch of hardened workpieces we recommend the construction comprising carbide insert. Center heads of type 0 / 01 consist of 60°-taper tip that are carbide coated.

Type FFBR / FBSR · tool steel or carbide

Technical data – type FFBR / FBSR · tool steel or carbide



with carbide insert

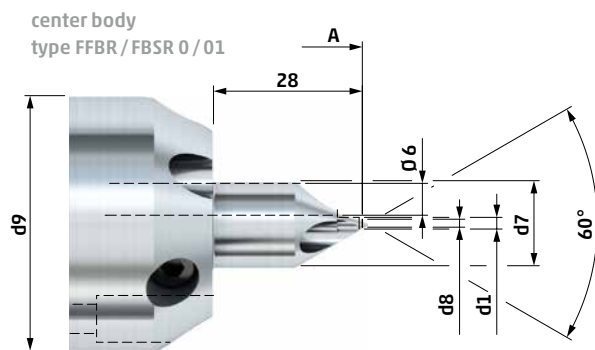
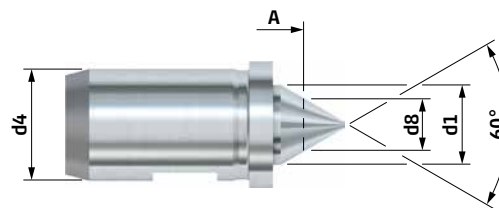

A overhang dimension of face driver to centre d8 (see page 54 - 55)

| for type FFBR / FBSR | d1 | d4 | center Ø | d7 | d8 | d9 | TYPE | |
|-------------------------|-----|----|----------|----|------|----|---------------|---------------|
| | | | | | | | TOOL STEEL | CARBIDE |
| | | | | | | | cat. no. | cat. no. |
| 0 | 3 | - | 1 - 3 | 18 | 1.5 | 48 | 734 15 | 734 31 |
| 01 | 5 | - | 1 - 5 | 18 | 3 | 48 | 734 16 | 734 32 |
| 11 | 7.8 | 6 | 2 - 6.5 | - | 4.25 | - | 734 11 | 734 33 |
| 1 | 9.8 | 8 | 4 - 8.5 | - | 6.25 | - | 734 02 | 734 34 |
| 2 | 10 | 14 | 4 - 9 | - | 6.5 | - | 734 03 | 734 35 |
| 3 | 12 | 18 | 6 - 11 | - | 8.5 | - | 734 04 | 734 36 |
| 4 | 16 | 20 | 10 - 15 | - | 12.5 | - | 734 05 | 734 38 |

Further center pins for other center holes upon request.



Face Drivers FFB / FFBH

with drive pins and fixed center pin

The entire surface of the workpiece can be finished with one single clamping and with a maximum of torque transmission. NEIDLEIN face drivers are clamping systems, which are equally suitable **for grinding soft and hard workpieces**.

Face drivers of types FFB / FFBH are power-operated on the side of the spindle.

Originally conceived for turning, face drivers of type FFB / FFBH provide a multitude of possible applications for grinding. Without retraction of drive pins and with NEIDLEIN retainer $\varnothing 100$ type FFB / FFBH provides an alternative to face drivers of type FFB / FFBH, especially when machining large-size workpieces.

When FFBH is used, the compensation of drive pins is implemented hydraulically, thus achieving excellent true runout results.

Type FFB with flange retainer

Type FFB is adapted onto the machine spindle using an adjustable flange adapter.



Type FFBH with flange retainer

Type FFBH is adapted onto the machine spindle using an adjustable flange adapter.



NEIDLEIN face drivers FFB / FFBH ensure:

- datum-point located in the center of the workpiece
- run-out deviation max.: 0.002 - 0.01 mm
- adjustment true via adjustable flange adapter for highest run-out requirements
- compensating drive components / optimal clamping of the workpiece
- easy handling
- face driver type FFBH comprises a hydraulic unit which is exchangeable as a cartridge

Technical data – type FFB face driver

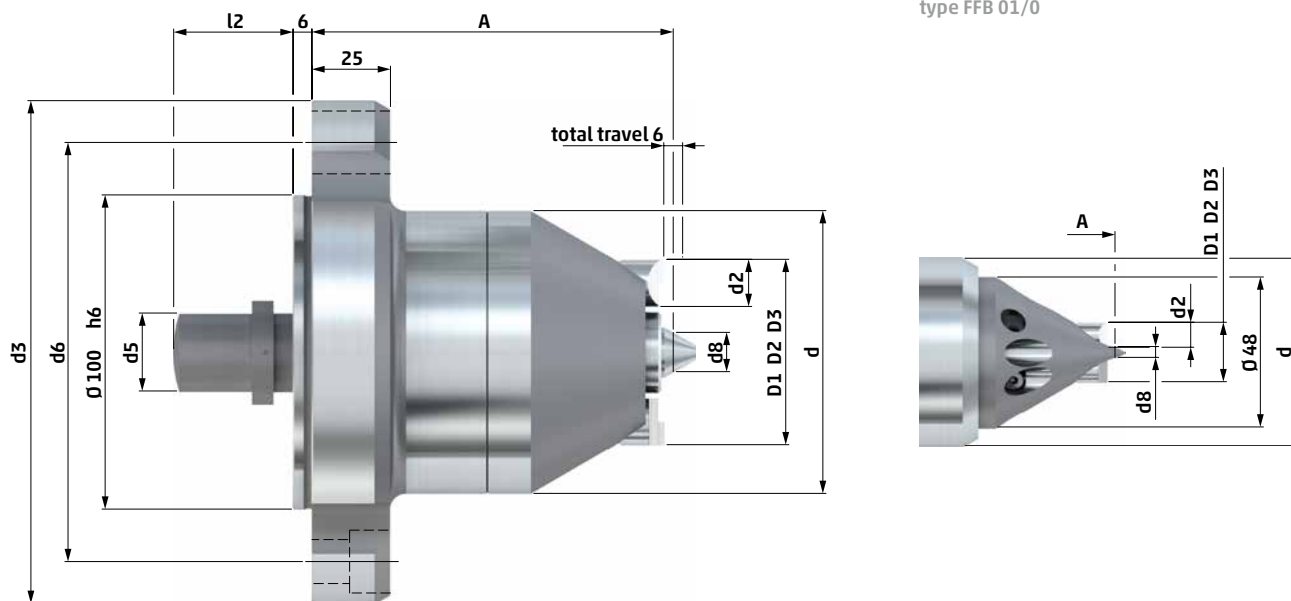

type FFB 01/0

| type FFB | d | center Ø | d2 | d3 | d5 | d6 | d8 | A | l2 | drive pins | clamping screws | | clamping Ø | | | cat. no. |
|-------------|-----|----------|----|-----|----|-------|------|-----|----|------------|-----------------|-----|------------|-----|-----|---------------|
| | | | | | | | | | | | type | pcs | D1 | D2 | D3 | |
| 01 | 60 | 1 - 5 | 6 | 160 | 18 | 133.4 | 3.5 | 115 | 38 | 3 | M12 | 3 | 8 | 11 | 17 | 731 01 |
| 0 | 60 | 1 - 3 | 8 | 160 | 18 | 133.4 | 3 | 115 | 38 | 3 | M12 | 3 | 6 | 11 | 19 | 731 12 |
| 11 | 42 | 2 - 6.5 | 6 | 160 | 12 | 133.4 | 4.25 | 115 | 38 | 3 | M12 | 3 | 11 | 14 | 20 | 731 11 |
| 1 | 48 | 4 - 8.5 | 8 | 160 | 18 | 133.4 | 6.25 | 115 | 38 | 3 | M12 | 3 | 13 | 18 | 26 | 731 02 |
| 2 | 70 | 4 - 9 | 10 | 160 | 22 | 133.4 | 6.5 | 115 | 38 | 3 | M12 | 3 | 26 | 31 | 36 | 731 03 |
| 3 | 70 | 6 - 11 | 10 | 160 | 22 | 133.4 | 8.5 | 115 | 38 | 3 | M12 | 3 | 34 | 39 | 44 | 731 04 |
| 35 | 80 | 4 - 9 | 15 | 160 | 22 | 133.4 | 6.5 | 115 | 38 | 3 | M12 | 3 | 29 | 39 | 49 | 731 13 |
| 4 | 90 | 10 - 15 | 15 | 160 | 25 | 133.4 | 12.5 | 115 | 38 | 5 | M12 | 3 | 39 | 49 | 59 | 731 05 |
| 45 | 100 | 10 - 15 | 15 | 160 | 25 | 133.4 | 12.5 | 115 | 54 | 5 | M12 | 3 | 49 | 59 | 69 | 731 06 |
| 5 | 132 | 10 - 15 | 20 | 160 | 25 | 133.4 | 12.5 | 115 | 54 | 5 | M12 | 3 | 69 | 84 | 99 | 731 07 |
| 55 | 182 | 10 - 15 | 20 | 220 | 40 | 171.4 | 12.5 | 155 | 54 | 5 | M16 | 3 | 110 | 125 | 140 | 731 08 |
| 6 | 220 | 10 - 15 | 20 | 250 | 40 | 210 | 12.5 | 171 | 54 | 5 | M20 | 3 | 140 | 155 | 170 | 731 09 |

- All face drivers are supplied without drive pins. (drive pins see page 62 - 63)
- Types FFB 01/0 are supplied with center body, all other types without center pin. (center pin see page 61)
- Diameter d8 refers to standard center pins. (see page 61)
- Further center pins for other center holes upon request.
- Mounting elements for face drivers see page 68 - 73.

A stable assembly on the machine spindle is implemented using an adjustable flange adapter. We supply these flange adapters for various sizes of spindle heads in standardized size (DIN ISO 702-1/DIN 702-1) or for vendor-specific spindle heads in particular. Thus face drivers of range FFB can be assembled universally on various machines. Driving components and center pin are easily exchanged from the front part of the machine.

As required, the face driver can be equipped with either drive pins comprising a chisel for machining soft workpieces, or with diamond coated drive pins for machining hardened workpieces.

Apart from the clamping diameters listed above D1, D2, D3, we can also provide alternative sizes upon request. We are also able to manufacture larger center pins or mushroom centers for oversize centering.

Technical data – type FFBH face driver

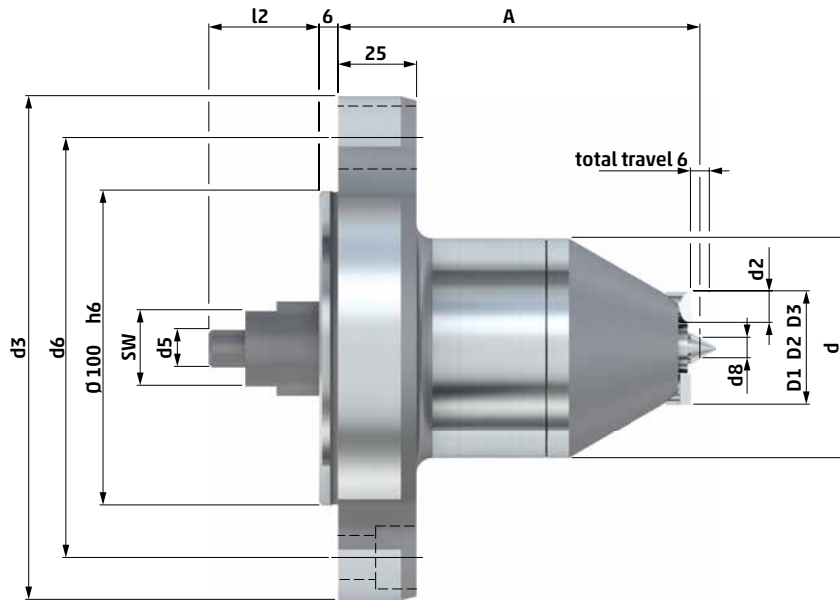

| type | d | center Ø | d2 | d3 | SW | d5 | d6 | d8 | A | l2 | drive pins | clamping screws | | | cat. no. | | |
|-----------|-----|----------|----|-----|----|----|-------|------|-----|----|------------|-----------------|-----|------------|----------|----|---------------|
| | | | | | | | | | | | | type | pcs | clamping Ø | | | |
| FFBH | | | | | | | | | | | | | D1 | D2 | D3 | | |
| 1 | 70 | 4-8.5 | 8 | 160 | 24 | 12 | 133.4 | 6.25 | 115 | 35 | 3 | M12 | 3 | 13 | 18 | 26 | 631 02 |
| 2 | 70 | 4-9 | 10 | 160 | 24 | 12 | 133.4 | 6.5 | 115 | 35 | 3 | M12 | 3 | 26 | 31 | 36 | 631 03 |
| 3 | 70 | 6-11 | 10 | 160 | 24 | 12 | 133.4 | 8.5 | 115 | 35 | 3 | M12 | 3 | 34 | 39 | 44 | 631 04 |
| 4 | 90 | 10-15 | 15 | 160 | 34 | 12 | 133.4 | 12.5 | 132 | 35 | 5 | M12 | 3 | 39 | 49 | 59 | 631 06 |
| 45 | 100 | 10-15 | 15 | 160 | 34 | 12 | 133.4 | 12.5 | 132 | 35 | 5 | M12 | 3 | 49 | 59 | 69 | 631 07 |
| 5 | 132 | 10-15 | 20 | 160 | 34 | 12 | 133.4 | 12.5 | 149 | 35 | 5 | M12 | 3 | 69 | 84 | 99 | 631 08 |

- All face drivers are supplied without drive pins and without center pins. (changeable parts see page 61-63)
- The diameter d8 refers to the standard center pins. (see page 61)
- Further center pins for other center holes upon request. (see page 30)
- Mounting elements for face drivers see page 68-73.

Technical data – type FFBH hydraulic unit

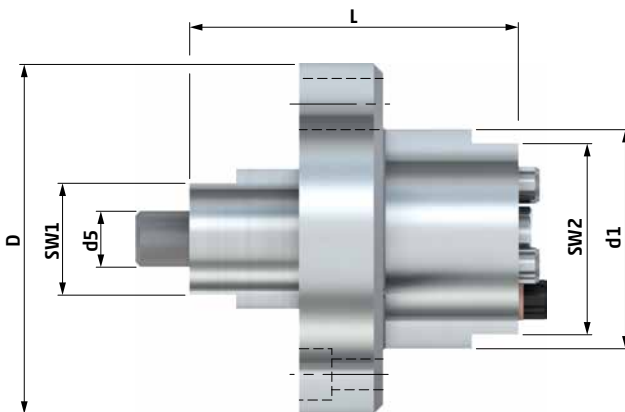

| type | SW1 | d5 | L | d1 | SW2 | D | cat. no. |
|-----------|-----|----|------|----|-----|-----|------------------|
| FFBH | | | | | | | |
| 1 | 24 | 12 | 70.5 | 47 | 41 | 75 | |
| 2 | 24 | 12 | 70.5 | 47 | 41 | 75 | 631 02 HE |
| 3 | 24 | 12 | 70.5 | 47 | 41 | 75 | |
| 4 | 34 | 12 | 70.5 | 65 | 59 | 93 | 631 06 HE |
| 45 | 34 | 12 | 70.5 | 65 | 59 | 93 | |
| 5 | 34 | 12 | 70.5 | 87 | 81 | 131 | 631 08 HE |

The general explanatory notes for this face driver FFBH can be obtained from the sheet "technical data – type FFB". For safe and smooth operation of face driver we recommend exchange of hydraulic unit after 1500 operating hours.

Furthermore, we offer the option for professional maintenance of the exchanged hydraulic units in our production plant.

Center Pins FFB / FFBH

for face drivers FFB / FFBH with fixed center pin

For maximum stability and run-out requirements the center pins are produced with narrow tolerances and are fixed safely via set screw and plane surface inside the face driver.

Due to the accurate assembly between center pin and head of face driver we ensure highly accurate replacement.

For a large batch of hardened workpieces we recommend the construction comprising carbide insert. Center heads of type 0 / 01 consist of 60°-taper tip that are carbide coated.

Type FFB / FFBH · tool steel or carbide

Technical data – type FFB / FFBH · tool steel or carbide



with carbide insert

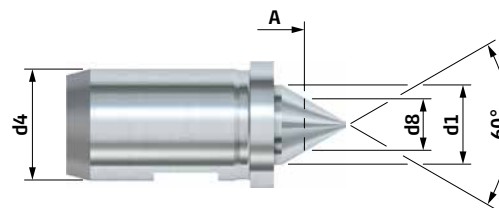

center body type FSB / SB 01 / 0

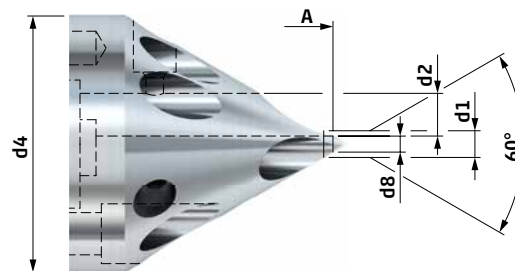

A overhang dimension of face driver to centre d8 (see page 59 - 60)

TYPE TOOL STEEL

TYPE CARBIDE

| for type FFB / FFBH | d1 | d2 | d4 | center Ø | d8 | cat. no. |
|---------------------|-----|----|----|----------|------|----------------|
| 01 | 5 | 6 | 48 | 1 - 5 | 3.5 | 734 01 |
| 0 | 3 | 8 | 48 | 1 - 3 | 3 | 734 101 |
| 11 | 7.8 | - | 6 | 2 - 6.5 | 4.25 | 734 11 |
| 1 | 9.8 | - | 8 | 4 - 8.5 | 6.25 | 734 02 |
| 2 | 10 | - | 14 | 4 - 9 | 6.5 | 734 03 |
| 3 | 12 | - | 18 | 6 - 11 | 8.5 | 734 04 |
| 35 | 10 | - | 14 | 4 - 9 | 6.5 | 734 12 |
| 4 | 16 | - | 20 | 10 - 15 | 12.5 | 734 05 |
| 45 | 16 | - | 28 | 10 - 15 | 12.5 | 734 06 |
| 5 | 16 | - | 35 | 10 - 15 | 12.5 | 734 07 |
| 55 | 16 | - | 35 | 10 - 15 | 12.5 | 734 08 |
| 6 | 16 | - | 35 | 10 - 15 | 12.5 | 734 09 |

| cat. no. |
|---------------|
| 734 43 |
| 734 44 |
| 734 33 |
| 734 34 |
| 734 35 |
| 734 36 |
| 734 37 |
| 734 38 |
| 734 39 |
| 73440 |
| 734 41 |
| 734 42 |

Further center pins for other center holes upon request. (see page 30)



Drive Pins FFB / FFBH · Chisel SR · Diamond

for torque transmission onto the workpiece when grinding soft and hardened workpieces

Drive pins made of hardened HSS with chisel are used **for grinding soft workpieces**. These are characterized by a high resistance to wear and tear and a maximum torque transmission.

Diamond coated drive pins are applied **for grinding hardened workpieces**. These are characterized by a high resistance to wear and tear, a maximum of torque transmission and by a high friction-coefficient.

Type FFB / FFBH · chisel SR · diamond

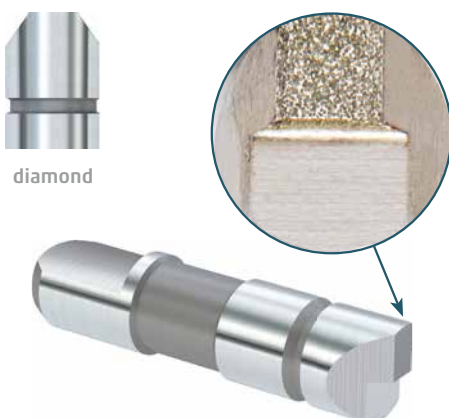

Technical data – type FFB / FFBH · chisel SR · diamond

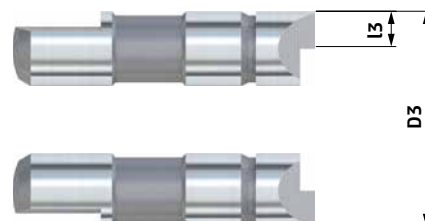
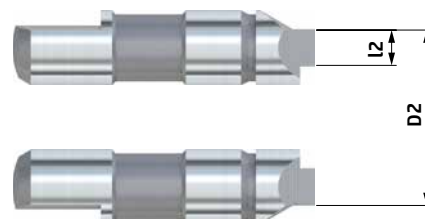
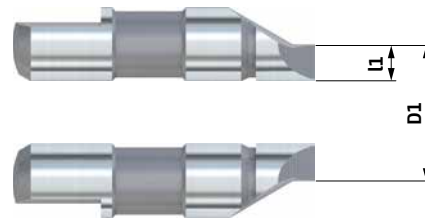

view from tailstock
onto the face driver

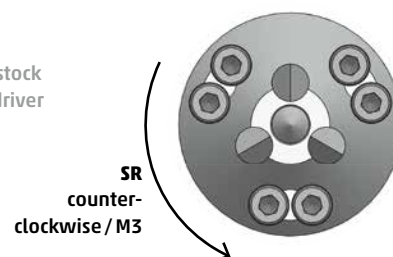

**TYPE
CHISEL SR**

| for type FFB/FFBH | d | clamping Ø | | | chisel length | | | cat. no. |
|----------------------|----|------------|-----|-----|---------------|----|----|----------------|
| | | D1 | D2 | D3 | l1 | l2 | l3 | |
| 01 | 6 | 8 | | | 1.5 | | | 736 600 |
| | 6 | | 11 | | | 2 | | 736 601 |
| | 6 | | | 17 | | | 2 | 736 602 |
| 0 | 8 | 6 | | | 1.5 | | | 736 603 |
| | 8 | | 11 | | | 2 | | 736 604 |
| | 8 | | | 19 | | | 2 | 736 605 |
| 11 | 6 | 11 | | | 1.5 | | | 736 606 |
| | 6 | | 14 | | | 2 | | 736 607 |
| | 6 | | | 20 | | | 2 | 736 608 |
| 1 | 8 | 13 | | | 1.5 | | | 736 609 |
| | 8 | | 18 | | | 2 | | 736 610 |
| | 8 | | | 26 | | | 2 | 736 611 |
| 2 | 10 | 26 | | | 3 | | | 736 612 |
| | 10 | | 31 | | | 3 | | 736 613 |
| | 10 | | | 36 | | | 3 | 736 614 |
| 3 | 10 | 34 | | | 3 | | | 736 615 |
| | 10 | | 39 | | | 3 | | 736 616 |
| | 10 | | | 44 | | | 3 | 736 617 |
| 35 | 15 | 29 | | | 3 | | | 736 618 |
| | 15 | | 39 | | | 3 | | 736 619 |
| | 15 | | | 49 | | | 3 | 736 620 |
| 4 | 15 | 39 | | | 3 | | | 736 621 |
| | 15 | | 49 | | | 3 | | 736 622 |
| | 15 | | | 59 | | | 3 | 736 623 |
| 45 | 15 | 49 | | | 3 | | | 736 624 |
| | 15 | | 59 | | | 3 | | 736 625 |
| | 15 | | | 69 | | | 3 | 736 626 |
| 5 | 20 | 69 | | | 4 | | | 736 627 |
| | 20 | | 84 | | | 4 | | 736 628 |
| | 20 | | | 99 | | | 4 | 736 629 |
| 55 | 20 | 110 | | | 4 | | | 736 630 |
| | 20 | | 125 | | | 4 | | 736 631 |
| | 20 | | | 140 | | | 4 | 736 632 |
| 6 | 20 | 140 | | | 4 | | | 736 633 |
| | 20 | | 155 | | | 4 | | 736 634 |
| | 20 | | | 170 | | | 4 | 736 635 |

**TYPE
DIAMOND COATING**

| chisel length | | | cat. no. |
|---------------|-----|-----|----------------|
| l1 | l2 | l3 | |
| 1.5 | | | 736 300 |
| | 3 | | 736 301 |
| | | 3 | 736 302 |
| 1.5 | | | 736 303 |
| | 4 | | 736 304 |
| | | 4 | 736 305 |
| 1.5 | | | 736 306 |
| | 3 | | 736 307 |
| | | 3 | 736 308 |
| 1.5 | | | 736 309 |
| | 4 | | 736 310 |
| | | 4 | 736 311 |
| 5 | | | 736 312 |
| | 5 | | 736 313 |
| | | 5 | 736 314 |
| 5 | | | 736 315 |
| | 5 | | 736 316 |
| | | 5 | 736 317 |
| 5 | | | 736 318 |
| | 5 | | 736 319 |
| | | 5 | 736 320 |
| 5 | | | 736 321 |
| | 5 | | 736 322 |
| | | 5 | 736 323 |
| 5 | | | 736 324 |
| | 5 | | 736 325 |
| | | 5 | 736 326 |
| 5 | | | 736 327 |
| | 7.5 | | 736 328 |
| | | 7.5 | 736 329 |
| 5 | | | 736 330 |
| | 7.5 | | 736 331 |
| | | 7.5 | 736 332 |
| 5 | | | 736 333 |
| | 7.5 | | 736 334 |
| | | 7.5 | 736 335 |

■ Further clamping Ø of drive pins upon request.



Face Drivers FDNC

with drive heads and movable center pin

Face drivers for clamping workpieces **for milling** free from backlash for gear hobbing, keyway milling and other surfaces.

Type FDNC with flange retainer

Type FDNC complete with changeable parts



NEIDLEIN face drivers FDNC ensure:

- machining free from backlash due to fixed driving elements
- stability and mounting of high transverse thrust using adjustable, spring-loaded center pins
- constant datum point on the end face of the workpiece
- adjustment of dissimilar bore holes
- adjustment true at drive head for high true running accuracy
- tapered design for optimum tool path

Clamping principle

The workpiece is pushed by the tailstock force against the moving center pin, which moves back until the workpiece face side is in contact with the drive head.

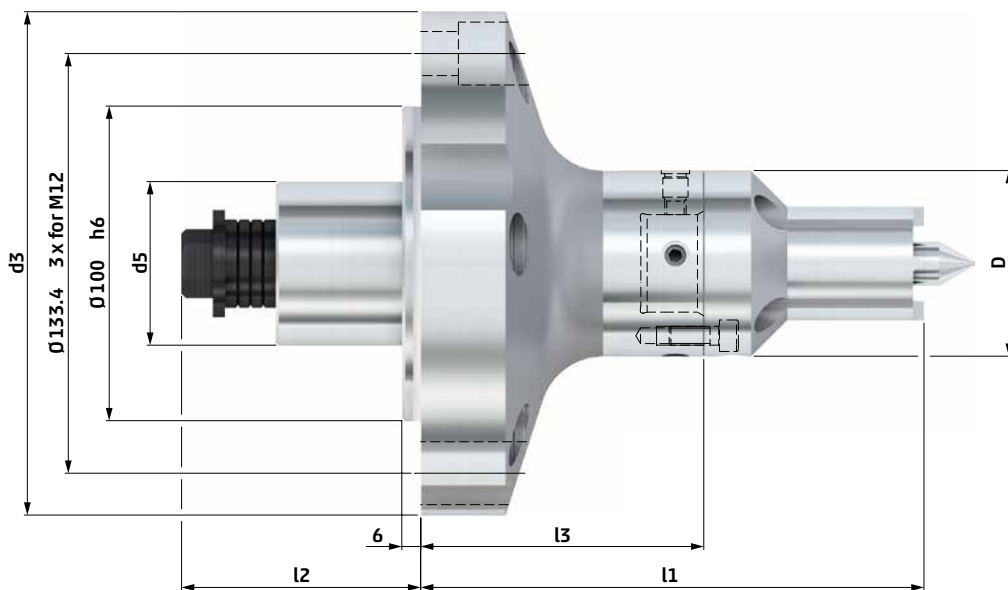
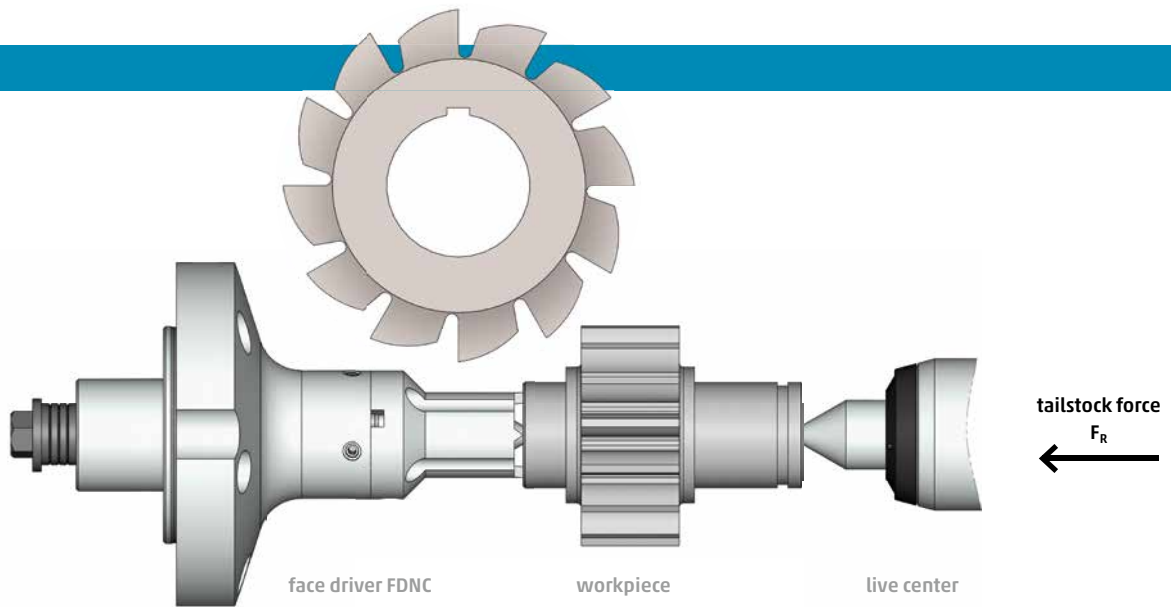

| type | D | d3 | d5 | l1 | l2 | l3 | cat. no. |
|------|----|-----|----|-----|----|----|----------|
| FDNC | | | | | | | |
| 11-4 | 59 | 160 | 52 | 160 | 77 | 90 | 732 01 |

■ Mounting elements for face drivers see page 68 - 73.



Drive Heads FDNC

changeable drive heads for basic body FDNC

Type FDNC · drive head



Technical data - type FDNC · drive head

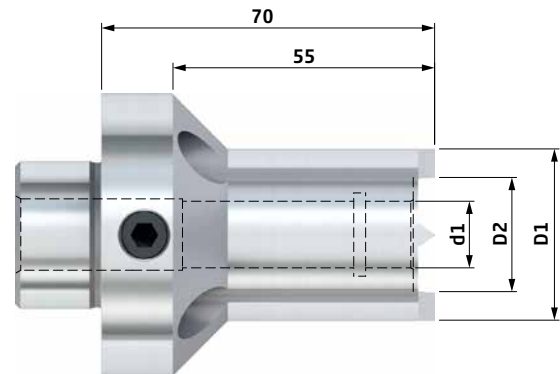

| for type FDNC | D1 | D2 | d1 | cat. no. |
|------------------|----|----|----|---------------|
| 11.11 | 11 | 7 | 6 | 737 01 |
| 11.14 | 14 | 9 | 6 | 737 02 |
| 11.18 | 18 | 12 | 6 | 737 03 |
| 1.22 | 22 | 14 | 8 | 737 04 |
| 1.26 | 26 | 18 | 8 | 737 05 |
| 2.30 | 30 | 20 | 14 | 737 06 |
| 2.36 | 36 | 24 | 14 | 737 07 |
| 3.39 | 39 | 29 | 18 | 737 08 |
| 3.44 | 44 | 34 | 18 | 737 09 |
| 4.49 | 49 | 39 | 24 | 737 10 |
| 4.59 | 59 | 49 | 24 | 737 11 |

- Additional dimensions for drive heads upon request.

Center Pins FDNC

changeable center pins for basic body
and drive heads FDNC

Type FDNC · center pin



Technical data - type FDNC · center pin

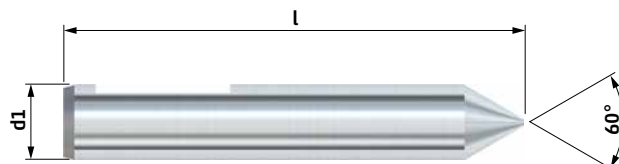

| for type FDNC | d1 | l | center Ø | cat. no. |
|------------------|----|----|----------|---------------|
| 11 | 6 | 78 | 1 - 6 | 733 01 |
| 1 | 8 | 80 | 1 - 8 | 733 02 |
| 2 | 14 | 86 | 1 - 14 | 733 03 |
| 3 | 18 | 89 | 3 - 18 | 733 04 |
| 4.1 | 24 | 89 | 3 - 18 | 733 05 |
| 4.2 | 24 | 96 | 16 - 24 | 733 06 |

■ Further center pins for other center holes upon request.

Flange Adapters ZFE (adjustable)

according to DIN ISO 702-1 (DIN 55028)
for mounting face drivers type FFB / FFBH
und reducing sleeves type RF

The flange adapter is used for direct mounting of **face driver type FFB and FFBH** with adjustment true. Adaption on machine tool spindle noses DIN ISO 702-1 (DIN 55026).

Our flange adapters are made of non-hardened steel. This helps to protect the spindle nose and serves for a better damping property.

Type ZFE with short taper

for adjustment at high run out requirements

Technical data – type ZFE with short taper

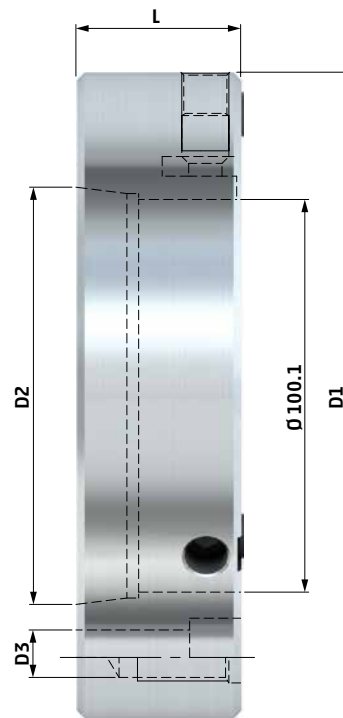

| type ZFE | spindle size | D1 | D2 | D3 für | L | for face drivers FFB / FFBH | cat. no. |
|----------|--------------|-----|---------|--------|----|-----------------------------|---------------|
| 5 | 5 | 160 | 82.563 | M10 | 40 | 01 - 5 | 742 12 |
| 6 | 6 | 165 | 106.375 | M12 | 42 | 01 - 5 | 742 14 |
| 8 | 8 | 220 | 139.719 | M16 | 42 | 01 - 55 | 742 16 |
| 11 | 11 | 280 | 196.869 | M20 | 60 | 01 - 6 | 742 18 |

- Adapters are supplied with mounting screws to suit the machine tool spindle nose.
- Other sizes and special adapters are available upon request.
- Hardened flange adapters are available upon request.

Clamping principle

Face drivers of the type FFB/FFBH and all other face drivers with retainer $\text{Ø}100$ which need a very precise run out adjustment are mounted onto the machine tool spindle via flange adapter ZFE.

Type ZFE with short taper

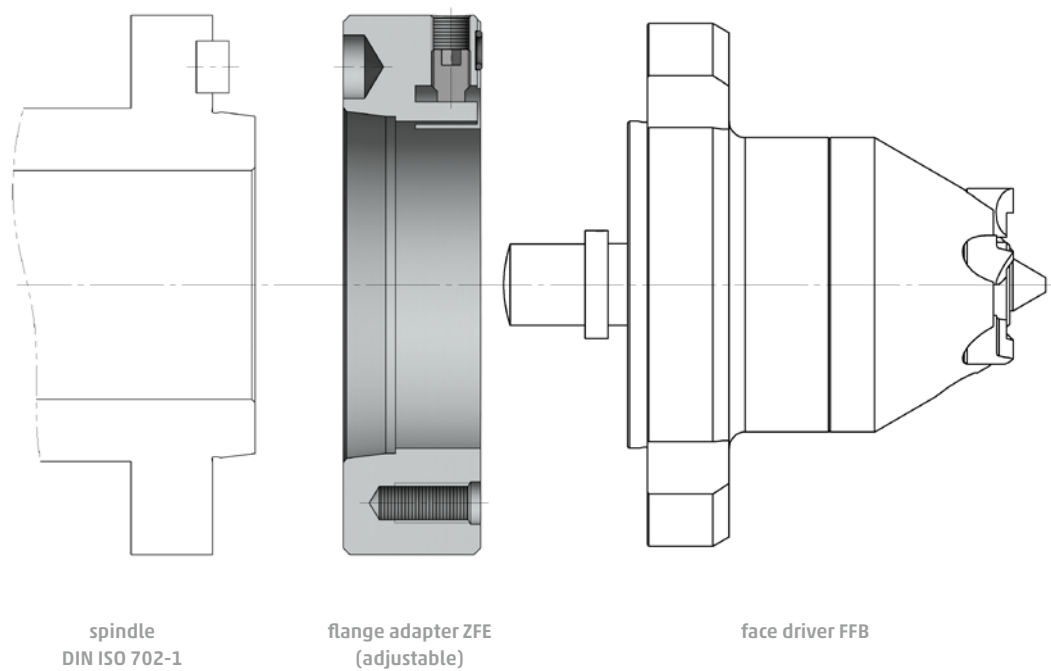

Reducing Adapters RF

for mounting clamping tools with morse taper shank

The reducing adapter is used for direct mounting of **face driver type SB**, **pipe driver type NDG** or of various center pins with morse taper shank.

Type RF with morse taper

Technical data – type RF with morse taper

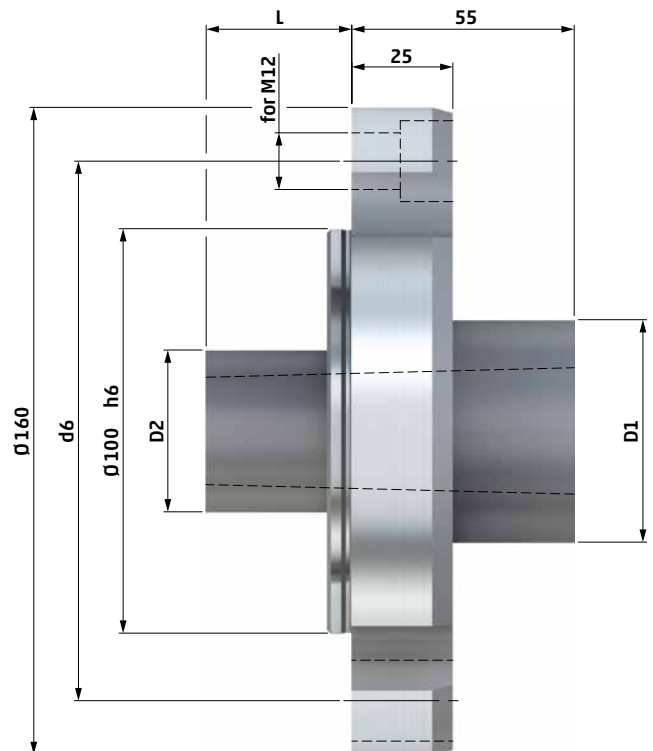

| type | MK | D1 | D2 | L | d6 | cat. no. |
|------|----|----|----|----|-------|----------|
| RF | | | | | | |
| 3 | 3 | 42 | 36 | 15 | 133.4 | 743 01 |
| 4 | 4 | 55 | 40 | 36 | 133.4 | 743 02 |
| 5 | 5 | 68 | 55 | 63 | 133.4 | 743 03 |

- Adapters are supplied with mounting screws to suit the machine tool spindle nose.
- Other sizes and special adapters are available upon request.

Clamping principle

For mounting a clamping tool with morse taper shank onto a machine tool spindle DIN ISO 702-1, a reducing flange RF is used by mounting it onto the machine tool spindle via flange adapter ZFE (e. g. at a double spindle CNC lathe).

Type RF with morse taper

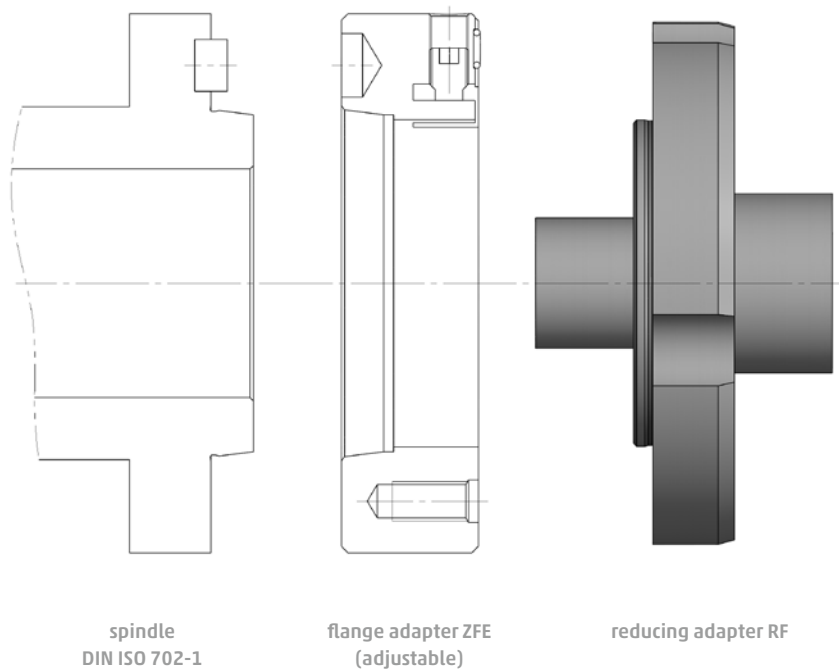

Reducing Sleeves RH

for reducing of morse cone retainers

The reducing sleeve is used for mounting of face driver type SB, pipe driver type NDG or of various center pins with morse taper shank. Demounting by means of extraction screw thread.

Type RH with morse taper



Technical data - type RH with morse taper

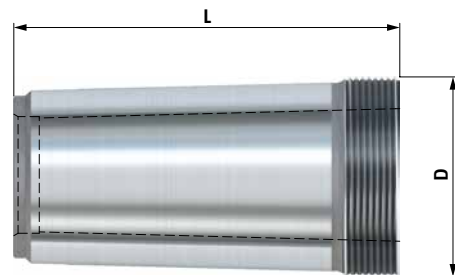

| type | MK | MK | D | L | cat. no. |
|------|---------|--------|--------------|-----|----------|
| RF | outside | inside | screw thread | | |
| 4/3 | 4 | 3 | M35 x 1.5 | 82 | 932 09 |
| 5/3 | 5 | 3 | M48 x 1.5 | 91 | 932 10 |
| 5/4 | 5 | 4 | M48 x 1.5 | 91 | 932 11 |
| 6/3 | 6 | 3 | M70 x 1.5 | 128 | 932 12 |
| 6/4 | 6 | 4 | M70 x 1.5 | 128 | 932 13 |
| 6/5 | 6 | 5 | M70 x 1.5 | 128 | 932 14 |

■ Other sizes and special sleeves are available upon request.

Clamping principle

For retaining a morse cone shank which is smaller than the available tailstock quill or machine tool spindle, a reducing sleeve with matching size is adapted.

For easy removal the reducing sleeves are made with an extraction thread.

Type RH with morse taper

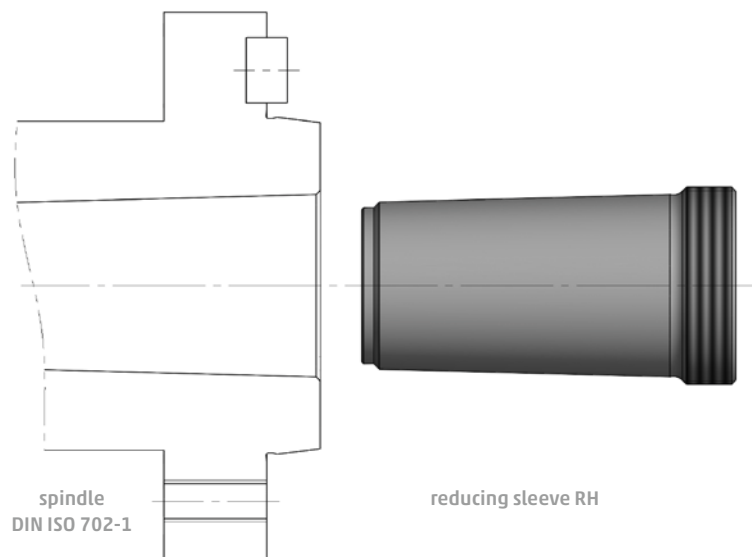

Extracting nut DIN 1804 h · for reducing sleeve RH

Type DIN 1804 h



Technical data - type DIN 1804 h

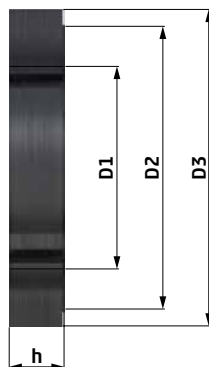

| D1 | D2 | D3 | h | cat. no. |
|-----------|----|-----|----|---------------|
| M35 x 1.5 | 47 | 55 | 11 | 830 41 |
| M48 x 1.5 | 67 | 75 | 13 | 830 43 |
| M70 x 1.5 | 90 | 100 | 14 | 830 44 |

Ultra Live Centers RN / RNC



for general use

NEIDLEIN ultra live centers are designed for employment **in turning, grinding and other production machine tools.**

Owing to the application of bearing and the stable design high axial and radial load can be absorbed accurately. Therefore our live centers are outstanding for any application, especially for tooling with face drivers.

Type RN with morse taper



with half carbide tip



with full carbide tip

↑ 0.005



↑ 0.003



NEIDLEIN revolving ultra live centers type RN / RNC ensure:

- application of live centers in case of high thrust and loading
- run-out deviation max.
0.005 mm · type turning
0.003 mm · type grinding
- enhanced true running accuracy HQ upon request
- maintenance-free, due to gasket system and life-time lubrication of bearings; gasket system comprising variable seal and steel protection cover
- excellent demounting by means of extracting nut and extracting disk, which ensures safe and easy removal of the live center from the tailstock spindle sleeve

Type RNC with morse taper

» **extended tooling clearance**
for better access of machining tools

↗ **0.005** 

↗ **0.003** 



 with carbide tip

TYPE TURNING

- with contact-free labyrinth seal
- true running accuracy max. 0.005 guaranteed

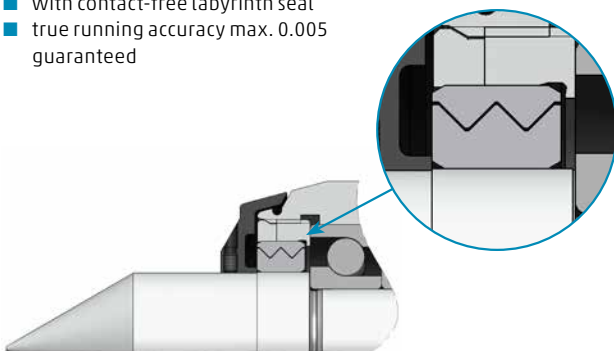

TYPE GRINDING

- with contact spindle seal
- true running accuracy max. 0.003 guaranteed

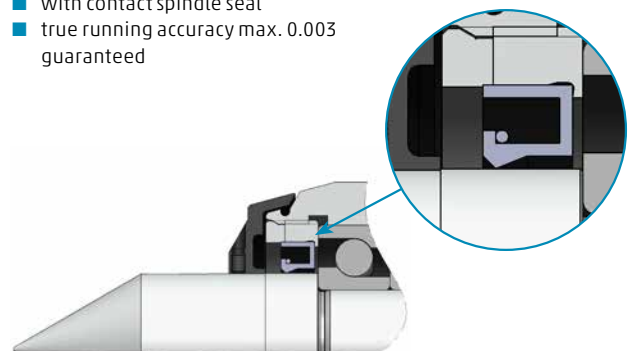

Technical data – type RN with morse taper

type tool steel tip

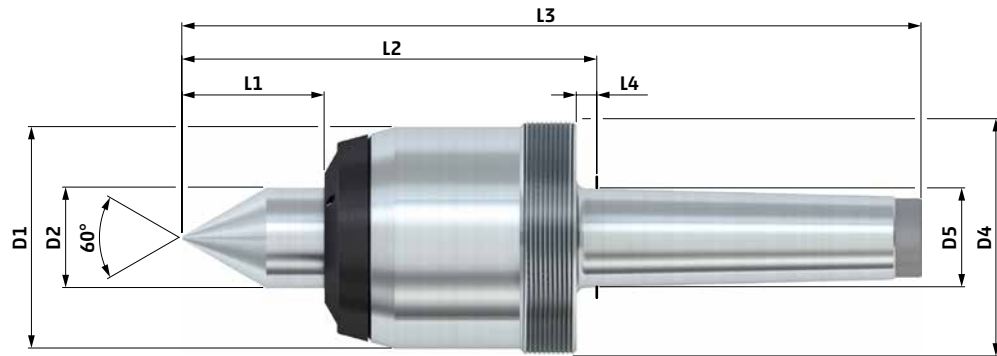
**WITH TOOL STEEL TIP****TYPE
TURNING****TYPE
GRINDING**

| type RN | MK | D1 | D2 | D4 | D5 | L1 | L2 | L3 | L4 | rpm max. [1/min] | cat. no. | cat. no. |
|------------|----|-----|----|-----------|-------|----|-------|-------|-----|---------------------|---------------|-----------------|
| 3 | 3 | 55 | 22 | M58 x 1.5 | 23.83 | 26 | 102 | 183 | 5 | 8000 | 812 01 | 812 0102 |
| | 4 | 55 | 22 | M58 x 1.5 | 31.27 | 26 | 103.5 | 206 | 6.5 | 8000 | 812 02 | 812 0202 |
| | 5 | 55 | 22 | M58 x 1.5 | 44.4 | 26 | 103.5 | 233 | 6.5 | 8000 | 812 03 | 812 0302 |
| 4 | 4 | 70 | 32 | M75 x 1.5 | 31.27 | 45 | 131.2 | 233.7 | 6.5 | 7000 | 812 04 | 812 0402 |
| | 5 | 70 | 32 | M75 x 1.5 | 44.4 | 45 | 131.2 | 260.7 | 6.5 | 7000 | 812 05 | 812 0502 |
| 5 | 5 | 92 | 45 | M95 x 2 | 44.4 | 60 | 156.2 | 285.7 | 6.5 | 5000 | 812 06 | 812 0602 |
| | 6 | 92 | 45 | M95 x 2 | 63.35 | 60 | 157.7 | 339.7 | 8 | 5000 | 812 07 | 812 0702 |
| 6 | 6 | 107 | 55 | M110 x 2 | 63.35 | 60 | 169.7 | 351.7 | 8 | 3000 | 812 08 | 812 0802 |

- Run-out deviation max.: type turning 0.005 mm · type grinding 0.003 mm.
- Extracting nuts and extracting disks see page 118 - 119 for accessories.
- Load chart see page 102.

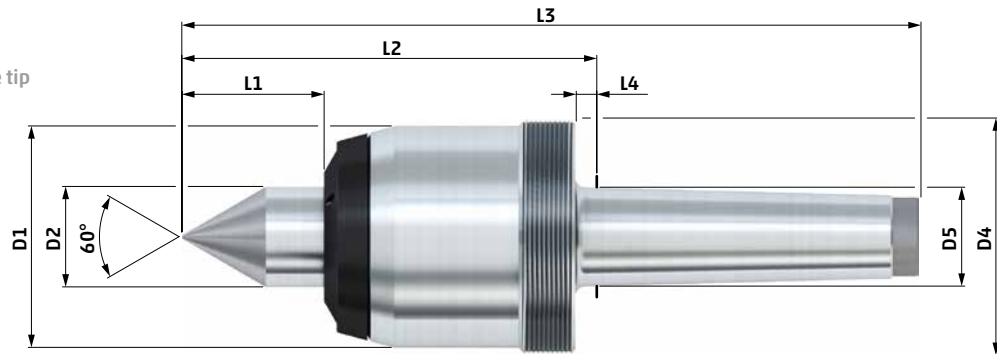

type full carbide tip

**WITH FULL CARBIDE TIP****TYPE
TURNING****TYPE
GRINDING**

| type RN | MK | D1 | D2 | D4 | D5 | L1 | L2 | L3 | L4 | rpm max. [1/min] | cat. no. | cat. no. |
|------------|----|-----|----|-----------|-------|----|-------|-------|-----|---------------------|-----------------|-----------------|
| 3 | 3 | 55 | 22 | M58 x 1.5 | 23.83 | 26 | 102 | 183 | 5 | 8000 | 812 0104 | 812 0106 |
| | 4 | 55 | 22 | M58 x 1.5 | 31.27 | 26 | 103.5 | 206 | 6.5 | 8000 | 812 0204 | 812 0206 |
| | 5 | 55 | 22 | M58 x 1.5 | 44.4 | 26 | 103.5 | 233 | 6.5 | 8000 | 812 0304 | 812 0306 |
| 4 | 4 | 70 | 32 | M75 x 1.5 | 31.27 | 45 | 131.2 | 233.7 | 6.5 | 7000 | 812 0404 | 812 0406 |
| | 5 | 70 | 32 | M75 x 1.5 | 44.4 | 45 | 131.2 | 260.7 | 6.5 | 7000 | 812 0504 | 812 0506 |
| 5 | 5 | 92 | 45 | M95 x 2 | 44.4 | 60 | 156.2 | 285.7 | 6.5 | 5000 | 812 0604 | 812 0606 |
| | 6 | 92 | 45 | M95 x 2 | 63.35 | 60 | 157.7 | 339.7 | 8 | 5000 | 812 0704 | 812 0706 |
| 6 | 6 | 107 | 55 | M110 x 2 | 63.35 | 60 | 169.7 | 351.7 | 8 | 3000 | 812 0804 | 812 0806 |

- Run-out deviation max.: type turning 0.005 mm · type grinding 0.003 mm.
- Extracting nuts and extracting disks see page 118 - 119 for accessories.
- Load chart see page 102.

Technical data - type RN with morse taper



type half carbide tip

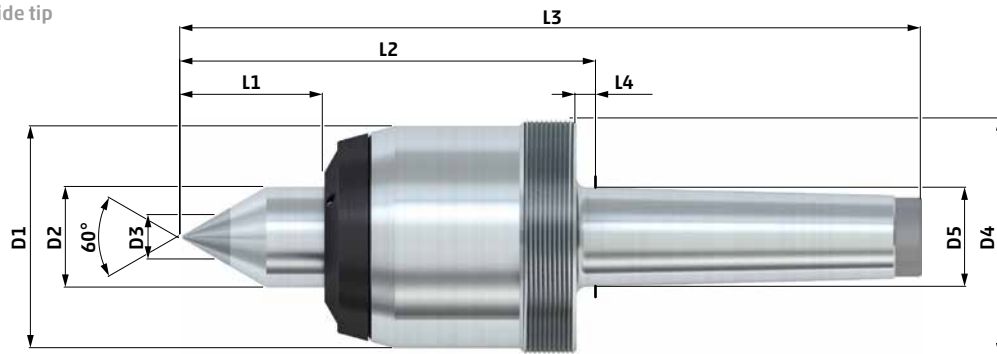

WITH HALF CARBIDE TIP

TYPE TURNING

TYPE GRINDING

| type RN | MK | D1 | D2 | D3 | D4 | D5 | L1 | L2 | L3 | L4 | rpm max. [1/min] | cat. no. | cat.no |
|---------|----|-----|----|----|-----------|-------|----|-------|-------|-----|------------------|-----------------|-----------------|
| 3 | 3 | 55 | 22 | 11 | M58 x 1.5 | 23.83 | 26 | 102 | 183 | 5 | 8000 | 812 0103 | 812 0105 |
| | 4 | 55 | 22 | 11 | M58 x 1.5 | 31.27 | 26 | 103.5 | 206 | 6.5 | 8000 | 812 0203 | 812 0205 |
| | 5 | 55 | 22 | 11 | M58 x 1.5 | 44.4 | 26 | 103.5 | 233 | 6.5 | 8000 | 812 0303 | 812 0305 |
| 4 | 4 | 70 | 32 | 14 | M75 x 1.5 | 31.27 | 45 | 131.2 | 233.7 | 6.5 | 7000 | 812 0403 | 812 0405 |
| | 5 | 70 | 32 | 14 | M75 x 1.5 | 44.4 | 45 | 131.2 | 260.7 | 6.5 | 7000 | 812 0503 | 812 0505 |
| 5 | 5 | 92 | 45 | 22 | M95 x 2 | 44.4 | 60 | 156.2 | 285.7 | 6.5 | 5000 | 812 0603 | 812 0605 |
| | 6 | 92 | 45 | 22 | M95 x 2 | 63.35 | 60 | 157.7 | 339.7 | 8 | 5000 | 812 0703 | 812 0705 |
| 6 | 6 | 107 | 55 | 28 | M110 x 2 | 63.35 | 60 | 169.7 | 351.7 | 8 | 3000 | 812 0803 | 812 0805 |

- Run-out deviation max.: type turning 0.005 mm · type grinding 0.003 mm.
- Extracting nuts and extracting disks see page 118 - 119 for accessories.
- Load chart see page 102.

Technical data – type RNC with morse taper

type tool steel tip

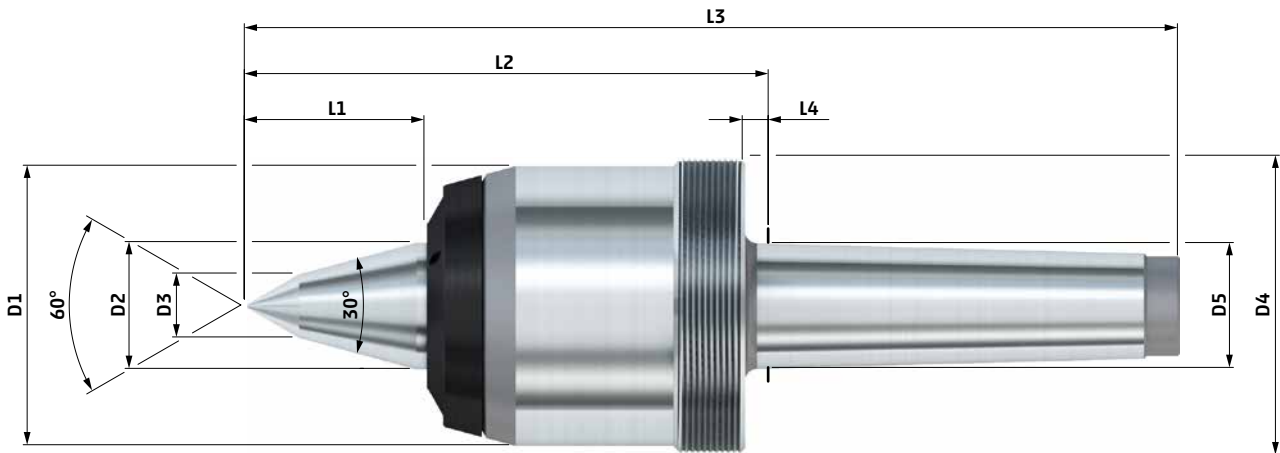
**WITH TOOL STEEL TIP****TYPE
TURNING****TYPE
GRINDING**

| type RNC | MK | D1 | D2 | D3 | D4 | D5 | L1 | L2 | L3 | L4 | rpm max. [1/min] | cat. no. | cat. no. |
|-------------|----------|-----|----|----|-----------|-------|----|-------|-------|-----|---------------------|---------------|-----------------|
| 3 | 3 | 55 | 22 | 10 | M58 x 1.5 | 23.83 | 32 | 108 | 189 | 5 | 8000 | 813 01 | 813 0102 |
| | 4 | 55 | 22 | 10 | M58 x 1.5 | 31.27 | 32 | 109.5 | 212 | 6.5 | 8000 | 813 02 | 813 0202 |
| | 5 | 55 | 22 | 10 | M58 x 1.5 | 44.4 | 32 | 109.5 | 239 | 6.5 | 8000 | 813 03 | 813 0302 |
| 4 | 4 | 70 | 32 | 16 | M75 x 1.5 | 31.27 | 45 | 131.2 | 233.7 | 6.5 | 7000 | 813 04 | 813 0402 |
| | 5 | 70 | 32 | 16 | M75 x 1.5 | 44.4 | 45 | 131.2 | 260.7 | 6.5 | 7000 | 813 05 | 813 0502 |
| 5 | 5 | 92 | 45 | 22 | M95 x 2 | 44.4 | 62 | 158.2 | 287.7 | 6.5 | 5000 | 813 06 | 813 0602 |
| | 6 | 92 | 45 | 22 | M95 x 2 | 63.35 | 62 | 159.7 | 341.7 | 8 | 5000 | 813 07 | 813 0702 |
| 6 | 6 | 107 | 55 | 28 | M110 x 2 | 63.35 | 72 | 181.7 | 363.7 | 8 | 3000 | 813 08 | 813 0802 |

- Run-out deviation max.: type turning 0.005 mm · type grinding 0.003 mm.
- Extracting nuts and extracting disks see page 118 - 119 for accessories.
- Load chart see page 102.

Technical data - type RNC with morse taper

HM type carbide tip

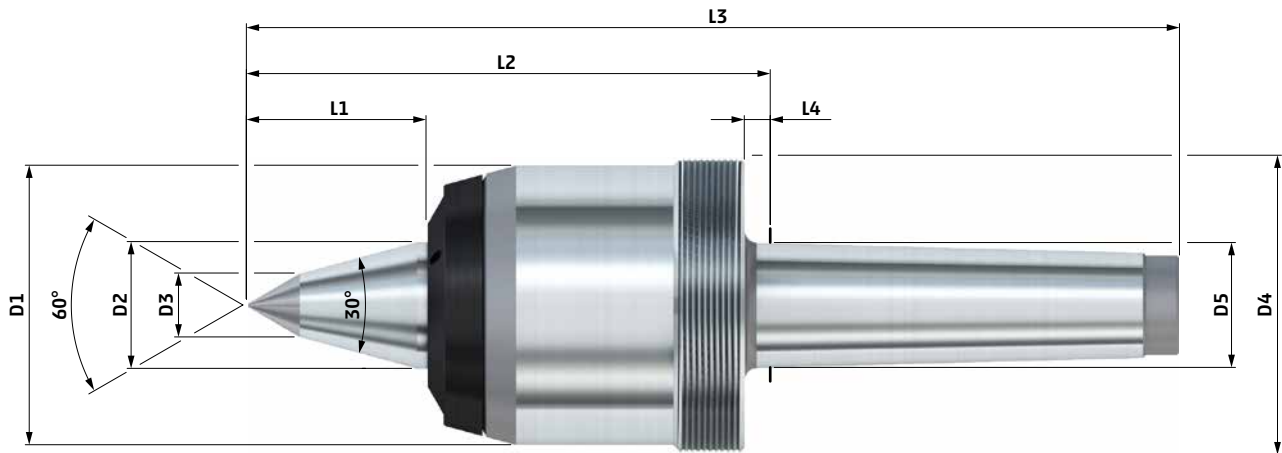

WITH CARBIDE TIP

TYPE TURNING

TYPE GRINDING

| type RNC | MK | D1 | D2 | D3 | D4 | D5 | L1 | L2 | L3 | L4 | rpm max. [1/min] | cat. no. |
|----------|----|-----|----|----|-----------|-------|----|-------|-------|-----|------------------|-----------------|
| 3 | 3 | 55 | 22 | 10 | M58 x 1.5 | 23.83 | 32 | 108 | 189 | 5 | 8000 | 813 0104 |
| | 4 | 55 | 22 | 10 | M58 x 1.5 | 31.27 | 32 | 109.5 | 212 | 6.5 | 8000 | 813 0204 |
| | 5 | 55 | 22 | 10 | M58 x 1.5 | 44.4 | 32 | 109.5 | 239 | 6.5 | 8000 | 813 0304 |
| 4 | 4 | 70 | 32 | 16 | M75 x 1.5 | 31.27 | 45 | 131.2 | 233.7 | 6.5 | 7000 | 813 0404 |
| | 5 | 70 | 32 | 16 | M75 x 1.5 | 44.4 | 45 | 131.2 | 260.7 | 6.5 | 7000 | 813 0504 |
| 5 | 5 | 92 | 45 | 22 | M95 x 2 | 44.4 | 62 | 158.2 | 287.7 | 6.5 | 5000 | 813 0604 |
| | 6 | 92 | 45 | 22 | M95 x 2 | 63.35 | 62 | 159.7 | 341.7 | 8 | 5000 | 813 0704 |
| 6 | 6 | 107 | 55 | 28 | M110 x 2 | 63.35 | 72 | 181.7 | 363.7 | 8 | 3000 | 813 0804 |

| cat. no. |
|-----------------|
| 813 0106 |
| 813 0206 |
| 813 0306 |
| 813 0406 |
| 813 0506 |
| 813 0606 |
| 813 0706 |
| 813 0806 |

- Run-out deviation max.: type turning 0.005 mm · type grinding 0.003 mm.
- Extracting nuts and extracting disks see page 118 - 119 for accessories.
- Load chart see page 102.

Ultra Live Centers RNA



high flexibility at large workpiece center holes

NEIDLEIN ultra live centers type RNA are designed for employment in **turning, grinding and other production machines**.

Type RNA with morse taper

high degree of flexibility for clamping of workpieces with large centers



0.01

incl. center cone



changeable center cone
see page 114

NEIDLEIN revolving ultra live centers type RNA ensure:

- application of live centers in case of high thrust and loading
- run-out deviation max.: 0.01 mm incl. center cone
- easy exchange of center cones using SK30 short taper interface and cylinder screw
- maintenance-free, due to gasket system and life-time lubrication of bearings; gasket system comprising variable seal and steel comprehensive protection cover
- excellent demounting by means of extracting nut and extracting disk, which ensures safe and easy removal of the live center from the tailstock spindle sleeve

TYPE TURNING

- with contact-free labyrinth seal

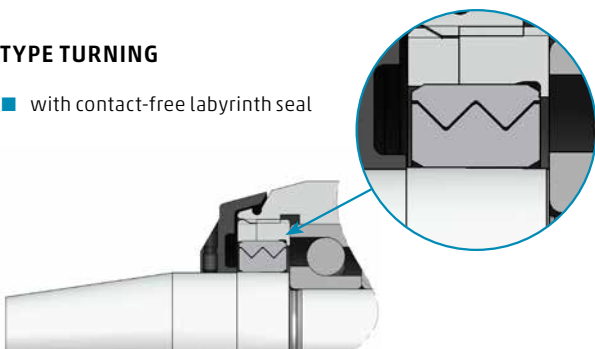

TYPE GRINDING

- with contact spindle seal

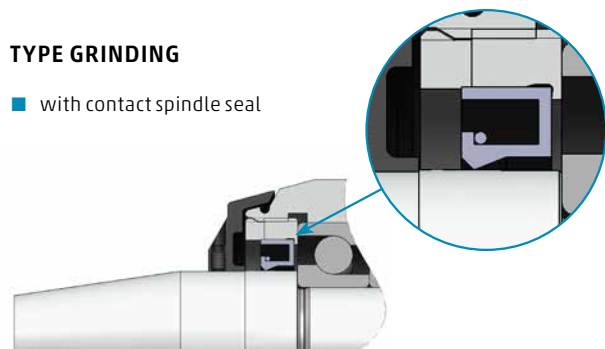

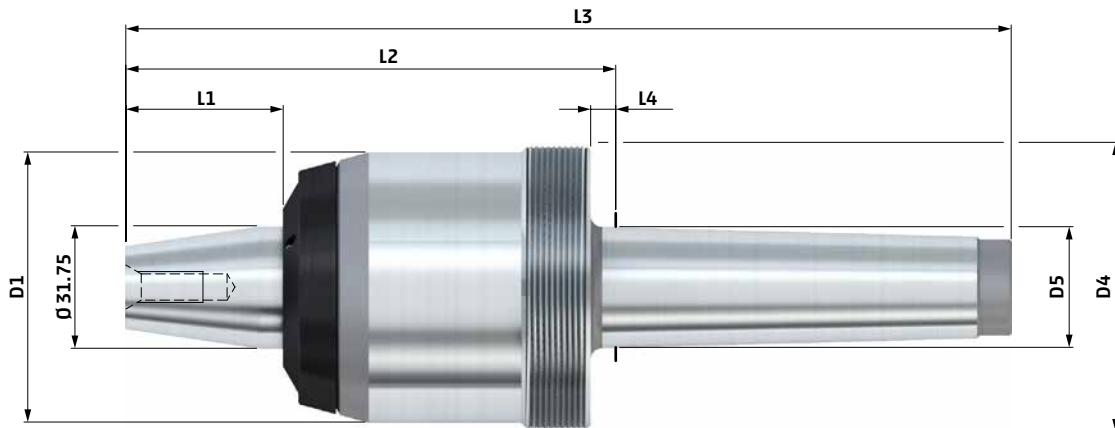
Technical data - type RNA with morse taper

| type RNA | MK | D1 | D4 | D5 | L1 | L2 | L3 | L4 | rpm max. [1/min] | TYPE | TYPE |
|-------------|----|-----|-----------|-------|----|-------|-------|-----|---------------------|----------|----------|
| | | | | | | | | | | TURNING | GRINDING |
| | | | | | | | | | | cat. no. | cat. no. |
| 4 | 4 | 70 | M75 x 1.5 | 31.27 | 41 | 127 | 229.5 | 6.5 | 7000 | TURNING | GRINDING |
| | 5 | 70 | M75 x 1.5 | 44.4 | 41 | 127 | 256.5 | 6.5 | 7000 | 814 04 | 814 0402 |
| 5 | 5 | 92 | M95 x 2 | 44.4 | 41 | 137.2 | 266.7 | 6.5 | 5000 | TURNING | GRINDING |
| | 6 | 92 | M95 x 2 | 63.35 | 41 | 138.7 | 320.7 | 8 | 5000 | 814 05 | 814 0502 |
| 6 | 6 | 107 | M110 x 2 | 63.35 | 41 | 150.7 | 332.7 | 8 | 3000 | TURNING | GRINDING |
| | | | | | | | | | | 814 06 | 814 0602 |
| | | | | | | | | | | 814 07 | 814 0702 |
| | | | | | | | | | | 814 08 | 814 0802 |

- Run-out deviation max.: 0.01 mm incl. center cone.
- Variety of center cones ranging from Ø 25 to Ø 315, see page 114.
- Special cones up to Ø 400 available upon customer's request.
- Extracting nuts and extracting disks see page 118 - 119 for accessories.
- Speed-dependent load see page 102.

Ultra Live Centers RNW



high flexibility by using different changable inserts

NEIDLEIN ultra live centers type RNW are designed for employment **in turning, grinding and other production machines.**

Type RNW with morse taper

the adaptation of various changeable inserts ensures a high degree of flexibility and saving of costs

 **0.01**
incl. insert



changeable inserts
see page 116 - 117

NEIDLEIN revolving ultra live centers type RNW ensure:

- application of live centers in case of high thrust and loading
- run-out deviation max.: 0.01 mm incl. insert
- easy exchange of changeable inserts using spanner flat and open-end wrench or Tommy bar
- maintenance-free, due to gasket system and life-time lubrication of bearings; gasket system comprising variable seal and steel comprehensive protection cover
- excellent demounting by means of extracting nut and extracting disk, which ensures safe and easy removal of the live center from the tailstock spindle sleeve

TYPE TURNING

- with contact-free labyrinth seal

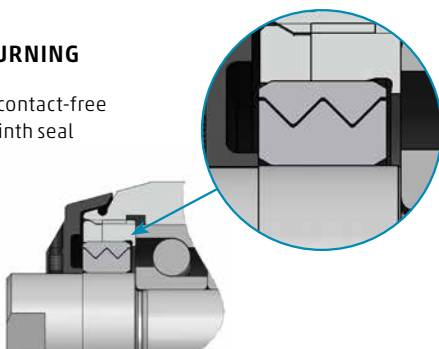

TYPE GRINDING

- with contact spindle seal

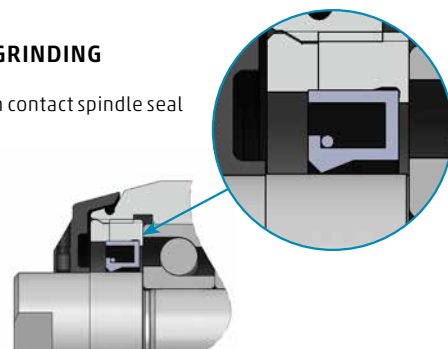

Technical data - type RNW with morse taper

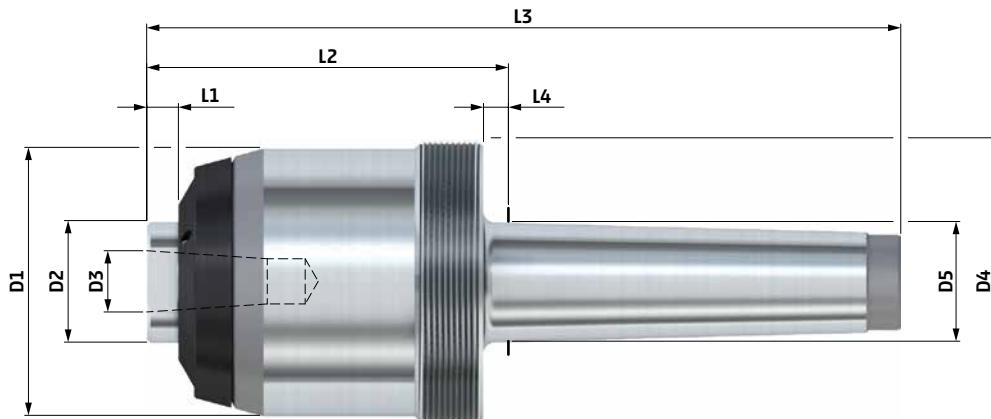

| type RNW | MK | D1 | D2 | D3 | D4 | D5 | L1 | L2 | L3 | L4 | rpm max. [1/min] | TYPE | TYPE |
|-------------|----|-----|----|----|-----------|-------|------|-------|-----|-----|---------------------|----------|----------|
| | | | | | | | | | | | | TURNING | GRINDING |
| | | | | | | | | | | | | cat. no. | cat. no. |
| 3 | 3 | 55 | 22 | 16 | M58 x 1.5 | 23.83 | 6.3 | 82 | 163 | 5 | 8000 | 815 01 | 815 0102 |
| | 4 | 55 | 22 | 16 | M58 x 1.5 | 31.27 | 6.3 | 83.5 | 186 | 6.5 | 8000 | 815 02 | 815 0202 |
| | 5 | 55 | 22 | 16 | M58 x 1.5 | 44.4 | 6.3 | 83.5 | 213 | 6.5 | 8000 | 815 03 | 815 0302 |
| 4 | 4 | 70 | 32 | 16 | M75 x 1.5 | 31.27 | 8.3 | 94.5 | 197 | 6.5 | 7000 | 815 04 | 815 0402 |
| | 5 | 70 | 32 | 16 | M75 x 1.5 | 44.4 | 8.3 | 94.5 | 224 | 6.5 | 7000 | 815 05 | 815 0502 |
| 5 | 5 | 92 | 45 | 22 | M95 x 2 | 44.4 | 10.3 | 106.5 | 236 | 6.5 | 5000 | 815 06 | 815 0602 |
| | 6 | 92 | 45 | 22 | M95 x 2 | 63.35 | 10.3 | 108 | 290 | 8 | 5000 | 815 07 | 815 0702 |
| 6 | 6 | 107 | 55 | 22 | M110 x 2 | 63.35 | 10.3 | 120 | 302 | 8 | 3000 | 815 08 | 815 0802 |

- Run-out deviation max.: 0.01 mm incl. insert.
- Various changeable inserts of different designs, see page 116 - 117.
- Special inserts available upon customer's request.
- Extracting nuts and extracting disks see page 118 - 119 for accessories.
- Speed-dependent load see page 102.



Ultra Live Centers RNF / RNCF

spring loaded live center

NEIDLEIN ultra live centers type RNF are especially suitable for **employment in turrets, in manual tailstocks and in case of linear thermal extension of workpieces.**

The spring loaded, moving spindle and the engraved scale rings enable the adjustment and/or programming of various axial forces.

Type RNF with morse taper

↑ 0.003



Type RNCF with morse taper

» extended tooling clearance
for better access of machining tools

↑ 0.003



NEIDLEIN ultra live centers type RNF / RNCF ensure:

- employment of live centers in turrets and manual tailstocks when hydraulic systems cannot guarantee any repositioning
- compensation if there is a linear thermal extension of workpieces or if the extension is caused by the process of machining
- run-out deviation max.: 0.003 mm
- maintenance free, due to the gasket system and the lifetime lubrication filling of the bearing
- obtaining of the axial forces applied via scale rings as well as clarification of the force ranges on the outside of the housing



Technical data - type RNF with morse taper

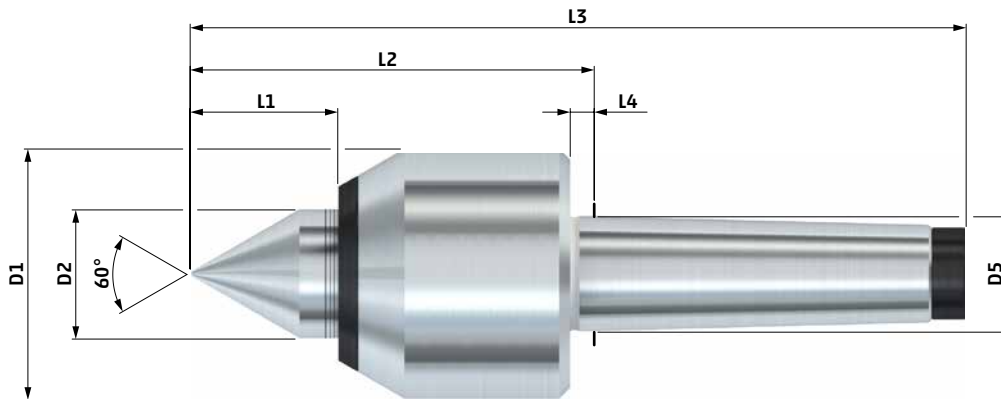

| type RNF | MK | D1 | D2 | D3 | D5 | L1 | L2 | L3 | L4 | rpm max. [1/min] | cat. no. |
|----------|----|----|----|----|-------|------|-------|-------|-----|------------------|----------|
| 3 | 3 | 55 | 25 | - | 23.83 | 28.5 | 84.5 | 165 | 5 | 4500 | 817 01 |
| | 4 | 55 | 25 | - | 31.27 | 28.5 | 86 | 185.5 | 6.5 | 4500 | 817 02 |
| | 5 | 55 | 25 | - | 44.4 | 28.5 | 86 | 215.5 | 6.5 | 4500 | 817 03 |
| 4 | 4 | 68 | 35 | - | 31.27 | 40 | 109.5 | 210.3 | 6.5 | 4000 | 817 04 |
| | 5 | 68 | 35 | - | 44.4 | 40 | 109.5 | 239 | 6.5 | 4000 | 817 05 |
| 5 | 5 | 92 | 50 | - | 44.4 | 53 | 138.5 | 268 | 6.5 | 3500 | 817 09 |

- Run-out deviation max.: 0.003 mm.
- Models with extraction thread or with special spindles are available upon customer's request.
- Load chart see page 103.

Technical data - type RNCF with morse taper

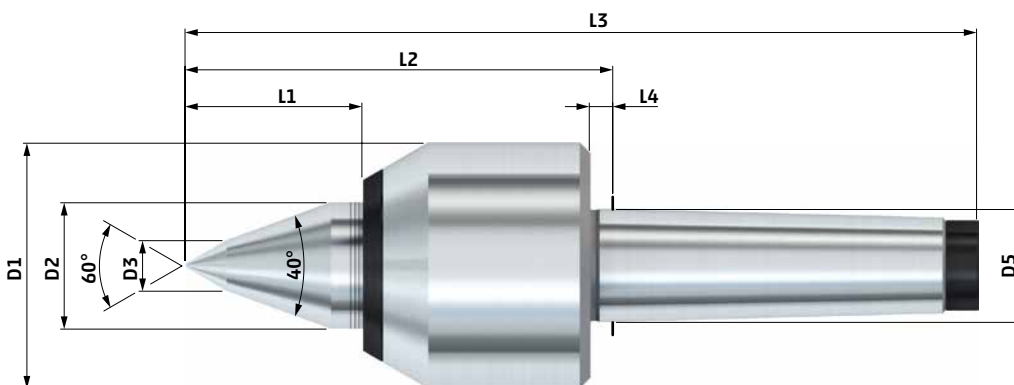

| type RNCF | MK | D1 | D2 | D3 | D5 | L1 | L2 | L3 | L4 | rpm max. [1/min] | cat. no. |
|-----------|----|----|----|----|-------|----|-------|-------|-----|------------------|----------|
| 3 | 3 | 55 | 25 | 12 | 23.83 | 37 | 93 | 173.5 | 5 | 4500 | 818 01 |
| | 4 | 55 | 25 | 12 | 31.27 | 37 | 94.5 | 194 | 6.5 | 4500 | 818 02 |
| | 5 | 55 | 25 | 12 | 44.4 | 37 | 94.5 | 224 | 6.5 | 4500 | 818 03 |
| 4 | 4 | 68 | 35 | 14 | 31.27 | 49 | 118.5 | 219.3 | 6.5 | 4000 | 818 04 |
| | 5 | 68 | 35 | 14 | 44.4 | 49 | 118.5 | 248 | 6.5 | 4000 | 818 05 |
| 5 | 5 | 92 | 50 | 14 | 44.4 | 65 | 150.5 | 280 | 6.5 | 3500 | 818 09 |

- Run-out deviation max.: 0.003 mm.
- Models with extraction thread or with special spindles are available upon customer's request.
- Load chart see page 103.



Ultra Live Centers RNF / RNCF VDI

spring loaded live center with CDI retainer

NEIDLEIN ultra live centers type RNF/RNCF VDI are adapted in the tool turret and are **especially suited for CNC machines without tailstock or with sub spindle.**

The spring loaded, moving spindle and the engraved scale rings enable the adjustment and/or programming of various axial forces.

Type RNF with VDI retainer

↑ 0.003



Type RNCF with VDI retainer

» extended tooling clearance
for better access of machining tools

↑ 0.003



NEIDLEIN ultra live centers type RNF / RNCF VDI ensure:

- employment of live centers in turrets when hydraulic systems cannot guarantee any repositioning
- compensation if there is a linear thermal extension of workpieces or if the extension is caused by the process of machining
- run-out deviation max.: 0.003 mm
- maintenance free, due to the gasket system and the lifetime lubrication filling of the bearing
- obtaining of the axial forces applied via scale rings as well as clarification of the force ranges on the outside of the housing



Technical data - type RNF with VDI retainer

DIN ISO 10889-1

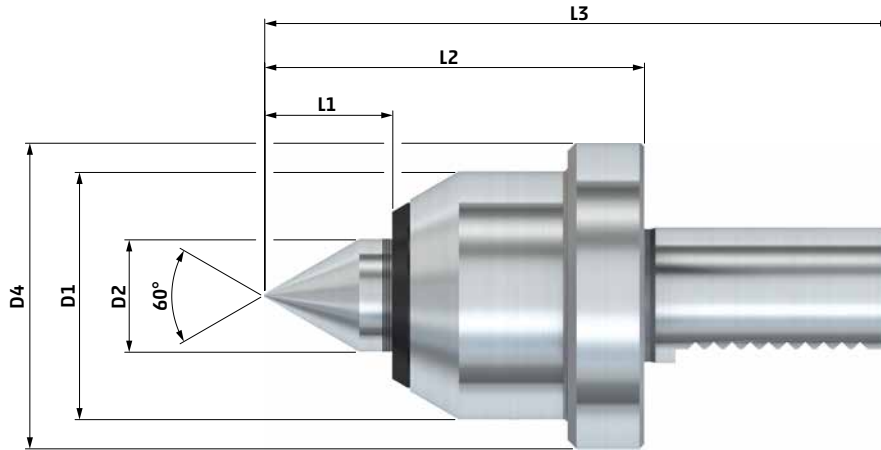

| type RNF | VDI | D1 | D2 | D3 | D4 | L1 | L2 | L3 | rpm max. [1/min] | cat. no. |
|----------|-----|----|----|----|----|------|------|-------|------------------|----------|
| 3 | 30 | 55 | 25 | - | 68 | 28.5 | 84.5 | 139.5 | 4500 | 817 06 |
| | 40 | 55 | 25 | - | 83 | 28.5 | 84.5 | 147.5 | 4500 | 817 07 |
| 4 | 40 | 68 | 35 | - | 83 | 40 | 108 | 171 | 4000 | 817 08 |

- Run-out deviation max.: 0.003 mm.
- Load chart see page 103.

Technical data - type RNCF with VDI retainer

DIN ISO 10889-1

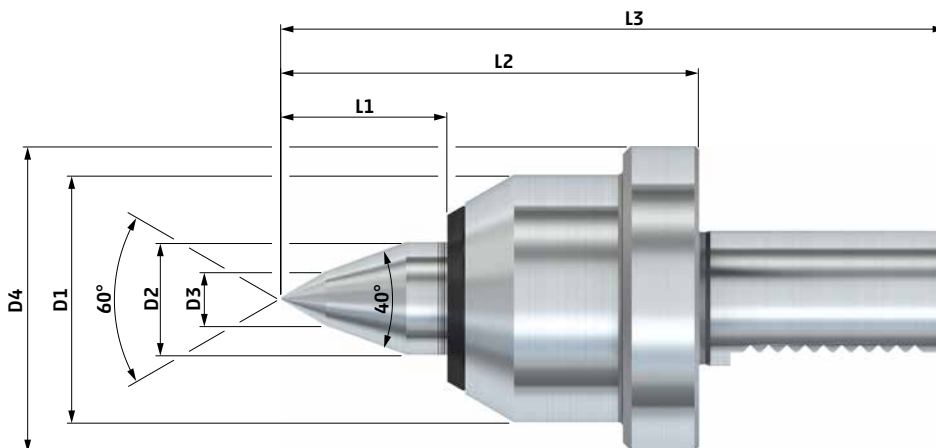

| type RNCF | VDI | D1 | D2 | D3 | D4 | L1 | L2 | L3 | rpm max. [1/min] | cat. no. |
|-----------|-----|----|----|----|----|----|-----|-----|------------------|----------|
| 3 | 30 | 55 | 25 | 12 | 68 | 37 | 93 | 148 | 4500 | 818 06 |
| | 40 | 55 | 25 | 12 | 83 | 37 | 93 | 156 | 4500 | 818 07 |
| 4 | 40 | 68 | 35 | 14 | 83 | 49 | 117 | 180 | 4000 | 818 08 |

- Run-out deviation max.: 0.003 mm.
- Load chart see page 103.



Ultra Live Centers RNH / RNCH

especially for hard turning operations

NEIDLEIN ultra live centers type RNH/RNCH are designed for hard turning operations which need a high precision and smooth running.

Type RNH with morse taper

↑ 0.003



HM with carbide tip

Type RNCH with morse taper

» extended tooling clearance
for better access of machining tools

↑ 0.003



HM with carbide tip

NEIDLEIN ultra live centers type RNH / RNCH ensure:

- by using of high precision bearings and a extended spindle, a increased smooth running can be possible
- run-out deviation max.: 0.003 mm
- with carbide tip for hardened workpieces
- maintenance free, due to the gasket system and the lifetime lubrication filling of the bearing
- short set-up

Technical data- type RNH with morse taper



type carbide tip

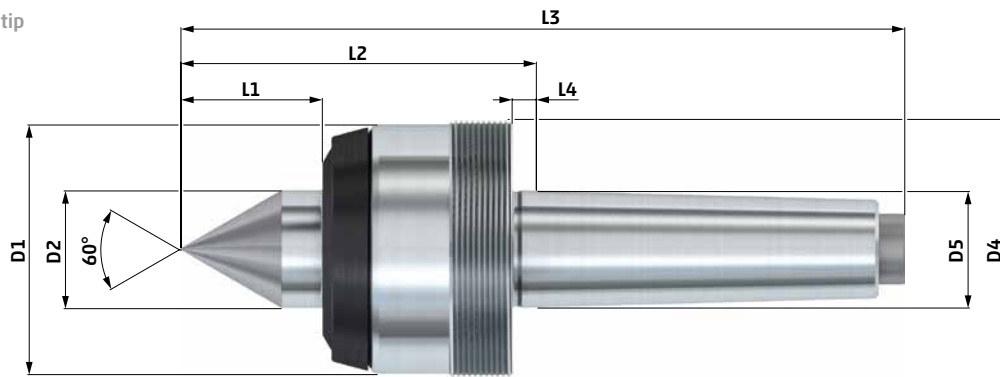

| type RNH | MK | D1 | D2 | D3 | D4 | L1 | L2 | L3 | L4 | rpm max. [1/min] | cat. no. |
|-------------|----|----|------|----|-----------|----|------|-------|-----|---------------------|-----------------|
| 2 | 3 | 45 | 18 | - | M48 x 1.5 | 20 | 67.5 | 153 | 5 | 8000 | 819 4904 |
| | 4 | 45 | 18 | - | M48 x 1.5 | 20 | 69 | 168 | 6.5 | 8000 | 819 5004 |
| 3 | 3 | 55 | 22 | - | M58 x 1.5 | 26 | 78.5 | 165.5 | 5 | 7000 | 819 5104 |
| | 4 | 55 | 22 | - | M58 x 1.5 | 26 | 80 | 179 | 6.5 | 7000 | 819 5204 |
| 4 | 5 | 55 | 22 | - | M58 x 1.5 | 26 | 80 | 216 | 6.5 | 7000 | 819 5304 |
| | 4 | 67 | 31.6 | - | M70 x 1.5 | 38 | 95 | 194 | 6.5 | 5000 | 819 5404 |
| | 5 | 67 | 31.6 | - | M70 x 1.5 | 38 | 95 | 231 | 6.5 | 5000 | 819 5504 |

- Run-out deviation max.: 0.003 mm.
- Extracting nuts and extracting disks see page 118 - 119 for accessories.
- Load chart see page 104.

Technical data- type RNCH with morse taper



type carbide tip

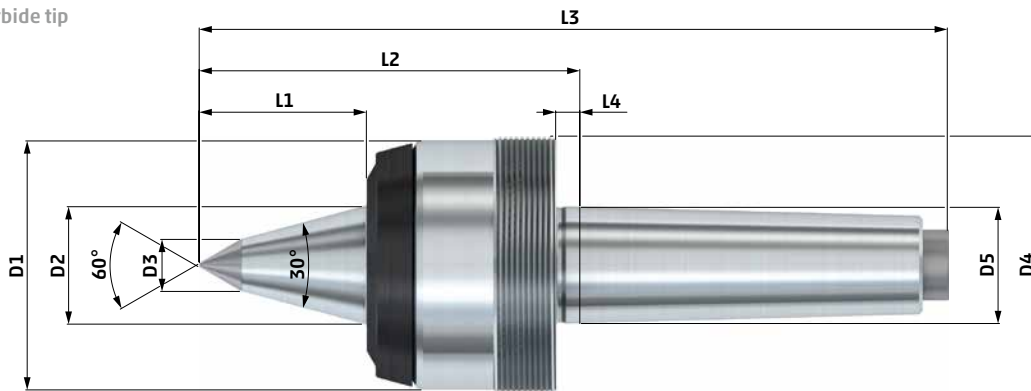

| type RNCH | MK | D1 | D2 | D3 | D4 | L1 | L2 | L3 | L4 | rpm max. [1/min] | cat. no. |
|--------------|----|----|------|----|-----------|----|------|-------|-----|---------------------|-----------------|
| 2 | 3 | 45 | 18 | 6 | M48 x 1.5 | 28 | 75.5 | 161 | 5 | 8000 | 819 6904 |
| | 4 | 45 | 18 | 6 | M48 x 1.5 | 28 | 77 | 176 | 6.5 | 8000 | 819 7004 |
| 3 | 3 | 55 | 22 | 10 | M58 x 1.5 | 32 | 84.5 | 171.5 | 5 | 7000 | 819 7104 |
| | 4 | 55 | 22 | 10 | M58 x 1.5 | 32 | 86 | 185 | 6.5 | 7000 | 819 7204 |
| 4 | 5 | 55 | 22 | 10 | M58 x 1.5 | 32 | 86 | 222 | 6.5 | 7000 | 819 7304 |
| | 4 | 67 | 31.6 | 14 | M70 x 1.5 | 45 | 102 | 201 | 6.5 | 5000 | 819 7404 |
| | 5 | 67 | 31.6 | 14 | M70 x 1.5 | 45 | 102 | 238 | 6.5 | 5000 | 819 7504 |

- Run-out deviation max.: 0.003 mm.
- Extracting nuts and extracting disks see page 118 - 119 for accessories.
- Load chart see page 104.



Ultre Live Centers RNS / RNCS

especially for grinding operations

NEIDLEIN ultra live centers type RNS / RNCS are **especially suited for the use in grinding and other production machine tools.**

By the specific arrangement of the bearings, the design of the live centers is very short and also the live centers can be

used for precise clamping of heavy workpieces with high axial forces. Therefore they are ideal for every use, especially in combination with face drivers.

Type RNS with morse taper

 0.003



with carbide tip
for hardened workpieces
and high production quantities

NEIDLEIN ultra live centers RNS / RNCS ensure:

- short projection length
- run-out deviation max.: 0.003 mm
- high true run accuracy even when using low axial forces
- application of live centers in case of high axial and radial loads
- maintenance free, due to the gasket system and the lifetime lubrication of the bearings
- easy and safe removal by means of extracting nut and extracting disk

Type RNCS with morse taper

» **extended tooling clearance**
for better access of machining tools



0.003

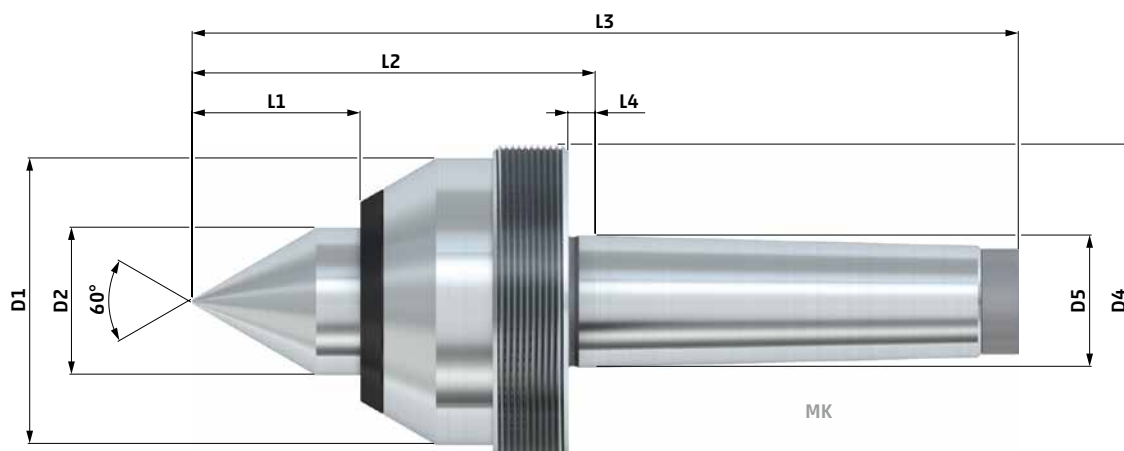

with carbide tip
for hardened workpieces
and high production quantities

Technical data – type RNS with morse taper

type caride tip



| type RNS | MK | D1 | D2 | D3 | D4 | D5 | L1 | L2 | L3 | L4 | rpm max. [1/min] | TYPE TOOL STEEL | TYPE CARBIDE |
|-------------|----|----|----|----|-----------|-------|----|------|-------|-----|---------------------|--------------------|-----------------|
| | | | | | | | | | | | | cat. no. | cat. no. |
| 1 | 2 | 34 | 18 | - | M36 x 1.5 | 17.78 | 20 | 61 | 125 | 5 | 7000 | 818 97 | 818 9706 |
| | 3 | 34 | 18 | - | M36 x 1.5 | 23.83 | 20 | 61 | 142 | 5 | 7000 | 818 98 | 818 9806 |
| 2 | 3 | 42 | 22 | - | M48 x 1.5 | 23.83 | 25 | 72 | 152.5 | 5 | 6000 | 818 99 | 818 9906 |
| | 4 | 42 | 22 | - | M48 x 1.5 | 31.27 | 25 | 73.5 | 173 | 6.5 | 6000 | 819 00 | 819 0006 |
| 3 | 3 | 55 | 25 | - | M58 x 1.5 | 23.83 | 28 | 74.5 | 155 | 5 | 4500 | 819 01 | 819 0106 |
| | 4 | 55 | 25 | - | M58 x 1.5 | 31.27 | 28 | 76 | 175.5 | 6.5 | 4500 | 819 02 | 819 0206 |
| | 5 | 55 | 25 | - | M58 x 1.5 | 44.4 | 28 | 76 | 205.5 | 6.5 | 4500 | 819 03 | 819 0306 |
| 4 | 4 | 68 | 35 | - | M75 x 1.5 | 31.27 | 40 | 96 | 197 | 6.5 | 4000 | 819 04 | 819 0406 |
| | 5 | 68 | 35 | - | M75 x 1.5 | 44.4 | 40 | 96 | 225.5 | 6.5 | 4000 | 819 05 | 819 0506 |
| 5 | 5 | 92 | 50 | - | M95 x 2 | 44.4 | 53 | 119 | 248.5 | 6.5 | 3600 | 819 06 | 819 0606 |

■ Run-out deviation max.: 0.003 mm.

■ Extracting nuts and extracting disks see page 118 - 119 for accessories.

■ Load chart see page 105.

Technical data - type RNCS with morse taper

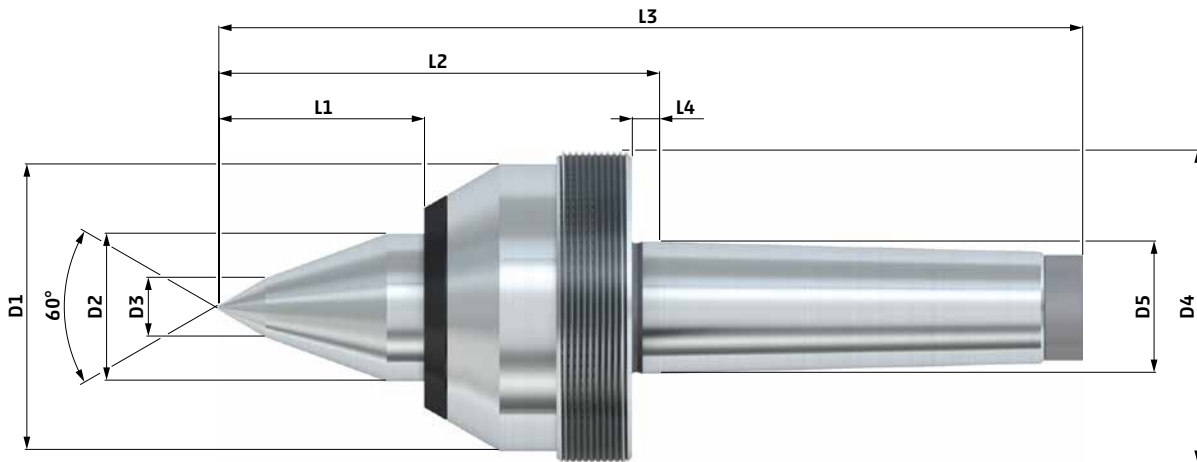

HM type caride tip



LIVE CENTERS · DEAD CENTERS

**TYPE
TOOL STEEL**

**TYPE
CARBIDE**

| type RNCS | MK | D1 | D2 | D3 | D4 | D5 | L1 | L2 | L3 | L4 | rpm max. [1/min] | cat. no. | cat. no. |
|--------------|----------|----|----|----|-----------|-------|----|-------|-------|-----|---------------------|---------------|-----------------|
| 1 | 2 | 34 | 18 | 6 | M36 x 1.5 | 17.78 | 26 | 67 | 131 | 5 | 7000 | 819 17 | 819 1706 |
| | 3 | 34 | 18 | 6 | M36 x 1.5 | 23.83 | 26 | 67 | 148 | 5 | 7000 | 819 18 | 819 1806 |
| 2 | 3 | 42 | 22 | 10 | M48 x 1.5 | 23.83 | 29 | 76 | 156.5 | 5 | 6000 | 819 19 | 819 1906 |
| | 4 | 42 | 22 | 10 | M48 x 1.5 | 31.27 | 29 | 77.5 | 177 | 6.5 | 6000 | 819 20 | 819 2006 |
| 3 | 3 | 55 | 25 | 12 | M58 x 1.5 | 23.83 | 37 | 83.5 | 164 | 5 | 4500 | 819 21 | 819 2106 |
| | 4 | 55 | 25 | 12 | M58 x 1.5 | 31.27 | 37 | 85 | 186.5 | 6.5 | 4500 | 819 22 | 819 2206 |
| | 5 | 55 | 25 | 12 | M58 x 1.5 | 44.4 | 37 | 85 | 214.5 | 6.5 | 4500 | 819 23 | 819 2306 |
| 4 | 4 | 68 | 35 | 14 | M75 x 1.5 | 31.27 | 49 | 105.5 | 206 | 6.5 | 4000 | 819 24 | 819 2406 |
| | 5 | 68 | 35 | 14 | M75 x 1.5 | 44.4 | 49 | 105 | 234.5 | 6.5 | 4000 | 819 25 | 819 2506 |
| 5 | 5 | 92 | 50 | 22 | M95 x 2 | 44.4 | 65 | 131 | 260.5 | 6.5 | 3600 | 819 26 | 819 2606 |

- Run-out deviation max.: 0.003 mm.
- Extracting nuts and extracting disks see page 118 - 119 for accessories.
- Load chart see page 105.

Load Charts for Live Centers

TYPE RN tool steel and with full carbide tip

TYPE RNC / RNA / RNW tool steel

| type | rpm [1/min] | typ of load | load [daN] | max. load [daN] | max. workpiece weight [daN] |
|----------|----------------|----------------|---------------|-----------------------|-----------------------------------|
| 3 | 250 | radial | 110 | 110 | 220 |
| | 500 | | 90 | | |
| | 1000 | | 70 | | |
| | 2000 | | 50 | | |
| | 3900 | | 30 | | |
| | 8000 | | 10 | | |
| | 250 | axial | 600 | 600 | |
| | 500 | | 510 | | |
| | 1000 | | 420 | | |
| | 2000 | | 320 | | |
| 3900 | 220 | | | | |
| 8000 | 130 | | | | |
| 4 | 250 | radial | 250 | 250 | 500 |
| | 500 | | 210 | | |
| | 1000 | | 170 | | |
| | 2000 | | 120 | | |
| | 3900 | | 70 | | |
| | 7000 | | 20 | | |
| | 250 | axial | 900 | 900 | |
| | 500 | | 800 | | |
| | 1000 | | 680 | | |
| | 2000 | | 560 | | |
| 3900 | 400 | | | | |
| 7000 | 200 | | | | |
| 5 | 250 | radial | 600 | 600 | 1200 |
| | 500 | | 520 | | |
| | 1000 | | 420 | | |
| | 2000 | | 310 | | |
| | 3900 | | 200 | | |
| | 5000 | | 50 | | |
| | 250 | axial | 1500 | 1500 | |
| | 500 | | 1350 | | |
| | 1000 | | 1100 | | |
| | 2000 | | 900 | | |
| 3900 | 600 | | | | |
| 5000 | 400 | | | | |
| 6 | 250 | radial | 750 | 750 | 1500 |
| | 500 | | 650 | | |
| | 1000 | | 520 | | |
| | 2000 | | 360 | | |
| | 3000 | | 200 | | |
| | 250 | | axial | | |
| | 500 | 1600 | | | |
| | 1000 | 1400 | | | |
| | 2000 | 1000 | | | |
| | 3000 | 700 | | | |

- The max. load is based on a bearing service life of approx. 2000 operating hours.
- Higher loads are possible for short periods.

TYPE RN with half carbide tip

TYPE RNC with carbide tip

| type | rpm [1/min] | typ of load | load [daN] | max. load [daN] | max. workpiece weight [daN] |
|----------|----------------|----------------|---------------|-----------------------|-----------------------------------|
| 3 | 250 | radial | 75 | 75 | 150 |
| | 500 | | 65 | | |
| | 1000 | | 55 | | |
| | 2000 | | 40 | | |
| | 3900 | | 25 | | |
| | 8000 | | 10 | | |
| | 250 | axial | 600 | 600 | |
| | 500 | | 510 | | |
| | 1000 | | 420 | | |
| | 2000 | | 330 | | |
| 3900 | 220 | | | | |
| 8000 | 130 | | | | |
| 4 | 250 | radial | 150 | 150 | 300 |
| | 500 | | 130 | | |
| | 1000 | | 110 | | |
| | 2000 | | 85 | | |
| | 3900 | | 60 | | |
| | 7000 | | 20 | | |
| | 250 | axial | 900 | 900 | |
| | 500 | | 800 | | |
| | 1000 | | 680 | | |
| | 2000 | | 560 | | |
| 3900 | 400 | | | | |
| 7000 | 200 | | | | |
| 5 | 250 | radial | 300 | 300 | 600 |
| | 500 | | 250 | | |
| | 1000 | | 200 | | |
| | 2000 | | 150 | | |
| | 3900 | | 100 | | |
| | 5000 | | 40 | | |
| | 250 | axial | 1500 | 1500 | |
| | 500 | | 1350 | | |
| | 1000 | | 1100 | | |
| | 2000 | | 900 | | |
| 3900 | 600 | | | | |
| 5000 | 400 | | | | |
| 6 | 250 | radial | 450 | 450 | 900 |
| | 500 | | 380 | | |
| | 1000 | | 300 | | |
| | 2000 | | 220 | | |
| | 3000 | | 120 | | |
| | 250 | | axial | | |
| | 500 | 1600 | | | |
| | 1000 | 1400 | | | |
| | 2000 | 1000 | | | |
| | 3000 | 700 | | | |

- The max. load is based on a bearing service life of approx. 2000 operating hours.
- Higher loads are possible for short periods.

TYPE RKA

| type | rpm [1/min] | typ of load | load [daN] | max. load [daN] | max. workpiece weight [daN] |
|------------|----------------|----------------|---------------|-----------------------|-----------------------------------|
| 6 | 250 | radial | 1000 | 1000 | 2000 |
| | 500 | | 850 | | |
| | 1000 | | 700 | | |
| | 2000 | | 500 | | |
| | 3000 | | 300 | | |
| MK5 | 250 | axial | 2000 | 2000 | 2000 |
| | 500 | | 1600 | | |
| | 1000 | | 1400 | | |
| | 2000 | | 1000 | | |
| | 3000 | | 700 | | |
| 6 | 250 | radial | 1250 | 1250 | 2500 |
| | 500 | | 1100 | | |
| | 1000 | | 900 | | |
| | 2000 | | 650 | | |
| | 3000 | | 350 | | |
| MK6 | 250 | axial | 2000 | 2000 | 2500 |
| | 500 | | 1600 | | |
| | 1000 | | 1400 | | |
| | 2000 | | 1000 | | |
| | 3000 | | 700 | | |

- The max. load is based on a bearing service life of approx. 2000 operating hours.
- Higher loads are possible for short periods.

TYPE RNF / RNCF

| type | rpm [1/min] | typ of load | load [daN] | max. load [daN] | max. workpiece weight [daN] |
|----------|----------------|----------------|---------------|-----------------------|-----------------------------------|
| 3 | 250 | radial | 150 | 150 | 300 |
| | 500 | | 130 | | |
| | 1000 | | 105 | | |
| | 1800 | | 80 | | |
| | 3000 | | 50 | | |
| 3 | 4500 | axial | 15 | 730 | 300 |
| | 250 | | 730 | | |
| | 500 | | 640 | | |
| | 1000 | | 520 | | |
| | 1800 | | 420 | | |
| 3 | 3000 | radial | 300 | 350 | 700 |
| | 4500 | | 180 | | |
| | 250 | | 350 | | |
| | 500 | | 300 | | |
| | 1000 | | 250 | | |
| 4 | 1800 | axial | 190 | 800 | 700 |
| | 2800 | | 110 | | |
| | 4000 | | 40 | | |
| | 250 | | 800 | | |
| | 500 | | 700 | | |
| 4 | 1000 | radial | 600 | 650 | 1300 |
| | 1800 | | 500 | | |
| | 2800 | | 300 | | |
| | 4000 | | 200 | | |
| | 250 | | 650 | | |
| 5 | 500 | axial | 1350 | 1350 | 1300 |
| | 900 | | 1200 | | |
| | 1600 | | 1000 | | |
| | 2400 | | 800 | | |
| | 3500 | | 600 | | |
| 5 | 250 | radial | 400 | 650 | 1300 |
| | 500 | | 540 | | |
| | 900 | | 420 | | |
| | 1600 | | 290 | | |
| | 2400 | | 160 | | |

- The max. load is based on a bearing service life of approx. 2000 operating hours.
- Higher loads are possible for short periods.

TYPE RNH

| type | rpm [1/min] | typ of load | load [daN] | max. load [daN] | max. workpiece weight [daN] |
|----------|----------------|----------------|---------------|-----------------------|-----------------------------------|
| 2 | 250 | radial | 100 | 100 | 200 |
| | 500 | | 85 | | |
| | 1000 | | 65 | | |
| | 2000 | | 45 | | |
| | 4000 | | 25 | | |
| | 8000 | 8 | | | |
| | 250 | axial | 600 | 600 | |
| | 500 | | 540 | | |
| | 1000 | | 470 | | |
| | 2000 | | 370 | | |
| 4000 | 260 | | | | |
| 8000 | 150 | | | | |
| 3 | 250 | radial | 175 | 175 | 350 |
| | 500 | | 170 | | |
| | 1000 | | 155 | | |
| | 2000 | | 115 | | |
| | 3900 | | 70 | | |
| | 7000 | 15 | | | |
| | 250 | axial | 800 | 800 | |
| | 500 | | 700 | | |
| | 1000 | | 600 | | |
| | 2000 | | 500 | | |
| 3900 | 300 | | | | |
| 7000 | 200 | | | | |
| 4 | 250 | radial | 300 | 300 | 600 |
| | 500 | | 260 | | |
| | 1000 | | 210 | | |
| | 2000 | | 155 | | |
| | 3300 | | 80 | | |
| | 5000 | 18 | | | |
| | 250 | axial | 1800 | 1800 | |
| | 500 | | 1600 | | |
| | 1000 | | 1350 | | |
| | 2000 | | 1100 | | |
| 3300 | 800 | | | | |
| 5000 | 400 | | | | |

- The max. load is based on a bearing service life of approx. 2000 operating hours.
- Higher loads are possible for short periods.

TYPE RNCH

| type | rpm [1/min] | typ of load | load [daN] | max. load [daN] | max. workpiece weight [daN] |
|----------|----------------|----------------|---------------|-----------------------|-----------------------------------|
| 2 | 250 | radial | 50 | 50 | 100 |
| | 500 | | 45 | | |
| | 1000 | | 35 | | |
| | 2000 | | 25 | | |
| | 4000 | | 15 | | |
| | 8000 | 4 | | | |
| | 250 | axial | 600 | 600 | |
| | 500 | | 540 | | |
| | 1000 | | 470 | | |
| | 2000 | | 370 | | |
| 4000 | 260 | | | | |
| 8000 | 150 | | | | |
| 3 | 250 | radial | 125 | 125 | 250 |
| | 500 | | 110 | | |
| | 1000 | | 85 | | |
| | 2000 | | 60 | | |
| | 3900 | | 30 | | |
| | 7000 | 10 | | | |
| | 250 | axial | 800 | 800 | |
| | 500 | | 700 | | |
| | 1000 | | 600 | | |
| | 2000 | | 500 | | |
| 3900 | 300 | | | | |
| 7000 | 200 | | | | |
| 4 | 250 | radial | 180 | 180 | 360 |
| | 500 | | 155 | | |
| | 1000 | | 125 | | |
| | 2000 | | 90 | | |
| | 3300 | | 55 | | |
| | 5000 | 15 | | | |
| | 250 | axial | 1300 | 1300 | |
| | 500 | | 1150 | | |
| | 1000 | | 970 | | |
| | 2000 | | 750 | | |
| 3300 | 550 | | | | |
| 5000 | 350 | | | | |

- The max. load is based on a bearing service life of approx. 2000 operating hours.
- Higher loads are possible for short periods.

TYPE RNS tool steel and with carbide tip

TYPE RNCS tool steel

| type | rpm [1/min] | typ of load | load [daN] | max. load [daN] | max. workpiece weight [daN] |
|------|----------------|----------------|---------------|-----------------------|-----------------------------------|
| 1 | 250 | radial | 75 | 75 | 150 |
| | 500 | | 65 | | |
| | 1000 | | 50 | | |
| | 2000 | | 40 | | |
| | 3900 | | 25 | | |
| | 7000 | 5 | | | |
| | 250 | axial | 260 | 260 | |
| | 500 | | 235 | | |
| | 1000 | | 205 | | |
| | 2000 | | 170 | | |
| 3900 | 130 | | | | |
| 7000 | 70 | | | | |
| 2 | 250 | radial | 125 | 125 | 250 |
| | 500 | | 105 | | |
| | 1000 | | 85 | | |
| | 2000 | | 60 | | |
| | 3900 | | 35 | | |
| | 6000 | 10 | | | |
| | 250 | axial | 420 | 420 | |
| | 500 | | 370 | | |
| | 1000 | | 320 | | |
| | 2000 | | 260 | | |
| 3900 | 190 | | | | |
| 6000 | 100 | | | | |
| 3 | 250 | radial | 150 | 150 | 300 |
| | 500 | | 130 | | |
| | 1000 | | 105 | | |
| | 2000 | | 80 | | |
| | 3200 | | 50 | | |
| | 4500 | 15 | | | |
| | 250 | axial | 500 | 500 | |
| | 500 | | 420 | | |
| | 1000 | | 340 | | |
| | 2000 | | 250 | | |
| 3200 | 180 | | | | |
| 4500 | 130 | | | | |
| 4 | 250 | radial | 350 | 350 | 700 |
| | 500 | | 300 | | |
| | 1000 | | 250 | | |
| | 1800 | | 190 | | |
| | 2800 | | 110 | | |
| | 4000 | 40 | | | |
| | 250 | axial | 800 | 800 | |
| | 500 | | 700 | | |
| | 1000 | | 600 | | |
| | 1800 | | 500 | | |
| 2800 | 300 | | | | |
| 4000 | 200 | | | | |
| 5 | 250 | radial | 650 | 650 | 1300 |
| | 500 | | 540 | | |
| | 1000 | | 420 | | |
| | 1700 | | 290 | | |
| | 2500 | | 160 | | |
| | 3600 | 60 | | | |
| | 250 | axial | 1400 | 1400 | |
| | 500 | | 1350 | | |
| | 1000 | | 1100 | | |
| | 1700 | | 900 | | |
| 2500 | 600 | | | | |
| 3600 | 400 | | | | |

- The max. load is based on a bearing service life of approx. 2000 operating hours.
- Higher loads are possible for short periods.

TYPE RNCS with carbide tip

| type | rpm [1/min] | typ of load | load [daN] | max. load [daN] | max. workpiece weight [daN] |
|------|----------------|----------------|---------------|-----------------------|-----------------------------------|
| 1 | 250 | radial | 25 | 25 | 50 |
| | 500 | | 22 | | |
| | 1000 | | 18 | | |
| | 2000 | | 15 | | |
| | 3900 | | 10 | | |
| | 7000 | 5 | | | |
| | 250 | axial | 260 | 260 | |
| | 500 | | 235 | | |
| | 1000 | | 205 | | |
| | 2000 | | 170 | | |
| 3900 | 130 | | | | |
| 7000 | 70 | | | | |
| 2 | 250 | radial | 50 | 50 | 100 |
| | 500 | | 45 | | |
| | 1000 | | 40 | | |
| | 2000 | | 30 | | |
| | 3900 | | 20 | | |
| | 6000 | 8 | | | |
| | 250 | axial | 420 | 420 | |
| | 500 | | 370 | | |
| | 1000 | | 320 | | |
| | 2000 | | 260 | | |
| 3900 | 190 | | | | |
| 6000 | 100 | | | | |
| 3 | 250 | radial | 100 | 100 | 200 |
| | 500 | | 90 | | |
| | 1000 | | 75 | | |
| | 2000 | | 60 | | |
| | 3200 | | 40 | | |
| | 4500 | 12 | | | |
| | 250 | axial | 500 | 500 | |
| | 500 | | 420 | | |
| | 1000 | | 340 | | |
| | 2000 | | 250 | | |
| 3200 | 180 | | | | |
| 4500 | 130 | | | | |
| 4 | 250 | radial | 150 | 150 | 300 |
| | 500 | | 130 | | |
| | 1000 | | 110 | | |
| | 1800 | | 80 | | |
| | 2800 | | 50 | | |
| | 4000 | 15 | | | |
| | 250 | axial | 800 | 800 | |
| | 500 | | 700 | | |
| | 1000 | | 600 | | |
| | 1800 | | 500 | | |
| 2800 | 300 | | | | |
| 4000 | 200 | | | | |
| 5 | 250 | radial | 300 | 300 | 600 |
| | 500 | | 260 | | |
| | 1000 | | 210 | | |
| | 1700 | | 150 | | |
| | 2500 | | 90 | | |
| | 3600 | 30 | | | |
| | 250 | axial | 1500 | 1500 | |
| | 500 | | 1350 | | |
| | 1000 | | 1100 | | |
| | 1700 | | 900 | | |
| 2500 | 600 | | | | |
| 3600 | 400 | | | | |

- The max. load is based on a bearing service life of approx. 2000 operating hours.
- Higher loads are possible for short periods.

Dead Centers FN / FNC



for general use

For rotating and fixed tailstock spindle sleeve. Designed for employment **in turning, grinding and other production machines.**

Type FN with morse taper

» can be reground



0.002



Type FNC with morse taper

» **extended tooling clearance**
for better access of machining tools



0.002

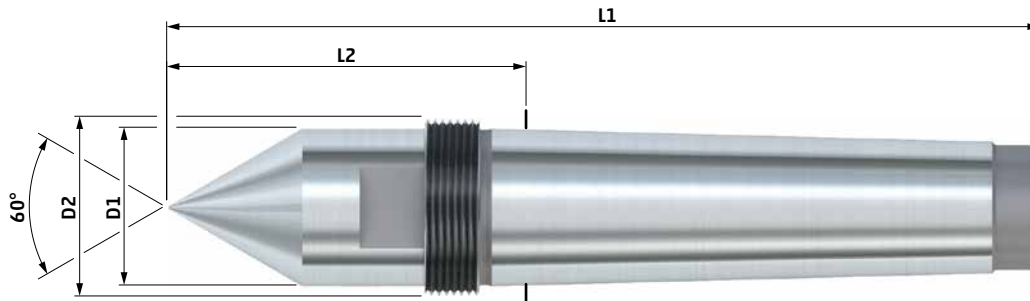

- Run-out deviation max.: 0.002 mm.
- Made of fully hardened tool-steel.
- All types with extracting thread to prevent spindle ball bearings or solid spindle sleeves from damage.
- Extracting nuts see page 118 - 119 for accessories.
- Max. load of the dead centers upon request.
- Special design upon request.

Technical data – type FN with morse taper**TYPE FN**

| MK | D1 | D2 | D3 | L1 | L2 | cat. no. |
|----------|----|-----------|----|-----|-----|---------------|
| 3 | 24 | M27 x 1.5 | - | 138 | 57 | 920 01 |
| 4 | 32 | M36 x 1.5 | - | 175 | 72 | 920 02 |
| 5 | 45 | M48 x 1.5 | - | 217 | 87 | 920 03 |
| 6 | 64 | M68 x 1.5 | - | 290 | 108 | 920 04 |

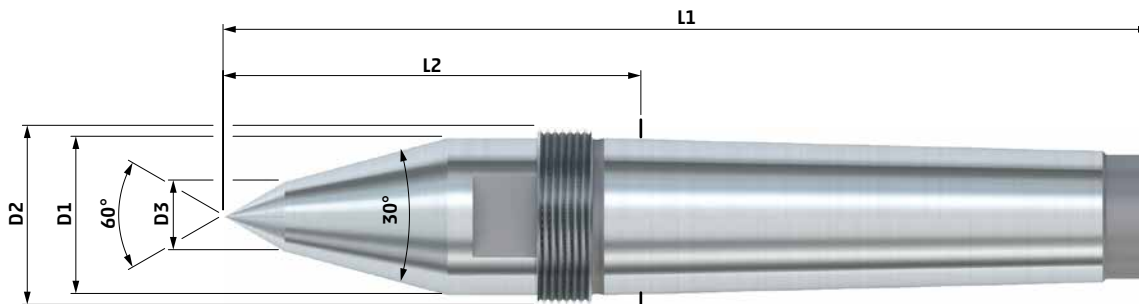
Technical data – type FNC with morse taper**TYPE FNC**

| MK | D1 | D2 | D3 | L1 | L2 | cat. no. |
|----------|----|-----------|----|-----|-----|---------------|
| 3 | 24 | M27 x 1.5 | 10 | 148 | 67 | 921 01 |
| 4 | 32 | M36 x 1.5 | 14 | 187 | 84 | 921 02 |
| 5 | 45 | M48 x 1.5 | 16 | 242 | 112 | 921 03 |
| 6 | 64 | M68 x 1.5 | 20 | 330 | 148 | 921 04 |



Dead Center Shanks FNA / FNW

high flexibility at different workpiece center holes

Type FNA with morse taper

» for large workpiece centers

high degree of flexibility for clamping of workpieces with large centers



0.01

incl. center cone



changeable center cones
see page 114

- Run-out deviation max.: 0.01 mm incl. center cone.
- Different types of center cones from Ø 25 to Ø 315, see page 114.
- Special center cones up to Ø 400 available upon customer's request.
- Extracting nuts, see page 118 - 119 for accessories.
- Max. load of the dead centers upon request.

Type FNW with morse taper

» maximum flexibility

the adaptation of various changeable inserts ensures a high degree of flexibility and saving of costs



0.01

incl. insert



changeable inserts
see page 116 - 117

- Run-out deviation max.: 0.01 mm incl. insert.
- Various changeable inserts of different designs, see page 116 - 117.
- Special inserts available upon customer's request.
- True running accuracy at center cone: max. 0.01
- Extracting nuts, see page 118 - 119 for accessories.
- Max. load of the dead centers upon request.

Technical data - type FNA with morse taper

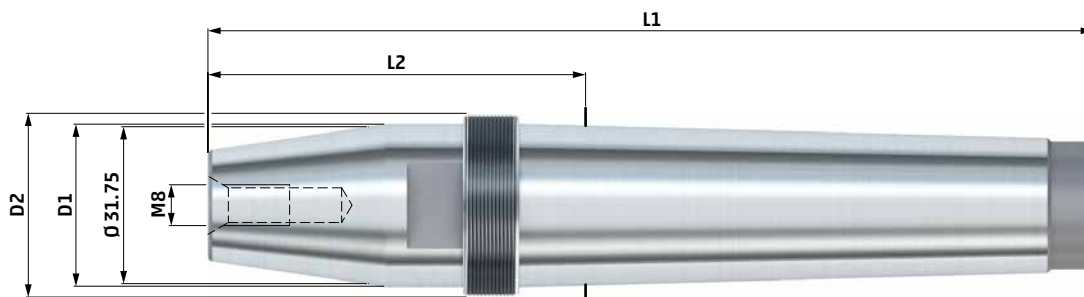

TYPE FN

| MK | D1 | D2 | D3 | L1 | L2 | cat. no. |
|----|----|-----------|----|-------|------|---------------|
| 3 | 32 | M27 x 1.5 | - | 149 | 68 | 922 01 |
| 4 | 32 | M36 x 1.5 | - | 173.5 | 71 | 922 02 |
| 5 | 45 | M48 x 1.5 | - | 202.5 | 73 | 922 03 |
| 6 | 64 | M68 x 1.5 | - | 263.5 | 81.5 | 922 04 |

Technical data - type FNW with morse taper

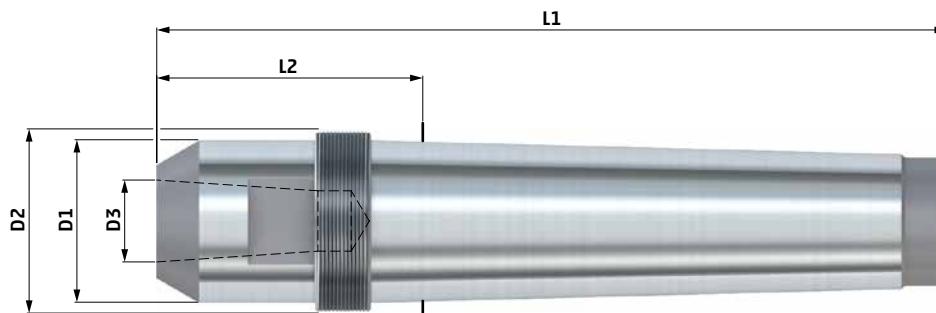

TYPE FNC

| MK | D1 | D2 | D3 | L1 | L2 | cat. no. |
|----|----|-----------|----|-------|----|---------------|
| 3 | 24 | M27 x 1.5 | 16 | 121 | 40 | 923 01 |
| 4 | 32 | M36 x 1.5 | 16 | 154.5 | 52 | 923 02 |
| 5 | 45 | M48 x 1.5 | 22 | 190 | 60 | 923 03 |
| 6 | 64 | M68 x 1.5 | 22 | 252 | 70 | 923 04 |

Carbide Dead Centers DIN 806



for hardened workpieces

To be applied with hardened workpieces. For headstocks and fixed tailstock spindle sleeves. Designed for employment in grinding and other production machines.

Type DIN 806 · model E



with full carbide tip



0.002



Type DIN 806 · model HE



flattened with half carbide tip



0.002



with half carbide tip



- Run-out deviation max.: 0.002 mm.
- With carbide insert.
- Max. load of the dead centers upon request.
- Special design upon request.

Technical data - type DIN 806 · model E/HE



similar to DIN 806 · model E
with full carbide tip

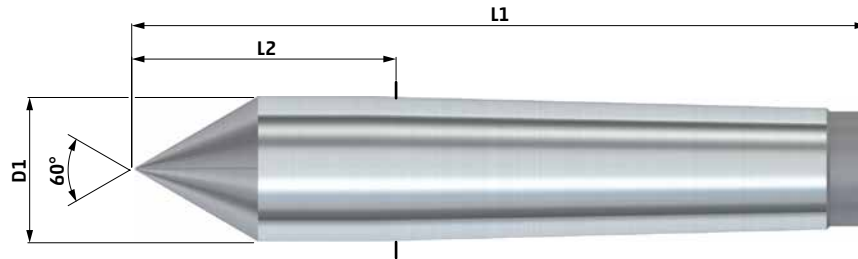

model E
with half carbide tip

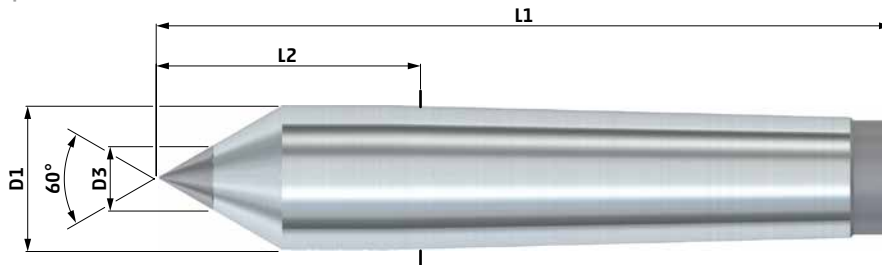

model HE
flattened with
half carbide tip

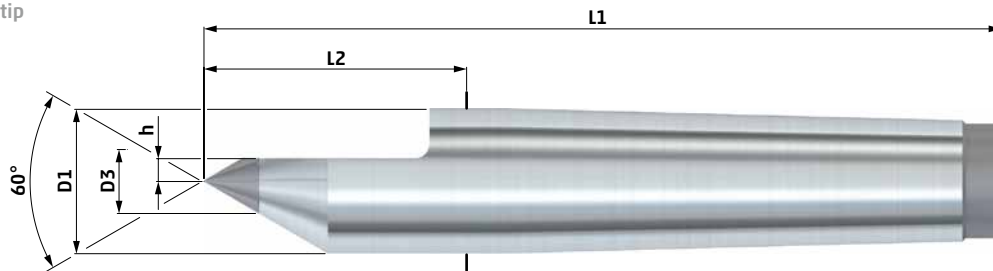

MODEL E



MODEL HE



| MK | D1 | L1 | L2 |
|----|------|-----|------|
| 1 | 12.2 | 80 | 26.5 |
| 2 | 18 | 100 | 36 |
| 3 | 24.1 | 125 | 44 |
| 4 | 31.6 | 160 | 57.5 |
| 5 | 44.7 | 200 | 70.5 |
| 6 | 63.8 | 270 | 88 |

| cat. no. |
|---------------|
| 910 02 |
| 910 05 |
| 910 08 |
| 910 11 |
| 910 14 |
| 910 18 |

| D3 | cat. no. |
|----|---------------|
| 7 | 910 01 |
| 7 | 910 03 |
| 11 | 910 06 |
| 14 | 910 09 |
| 18 | 910 12 |
| 18 | 910 15 |

| D3 | h | cat. no. |
|----|-----|---------------|
| 7 | 1.5 | 911 01 |
| 7 | 2 | 911 02 |
| 11 | 3 | 911 04 |
| 14 | 5 | 911 06 |
| 18 | 7 | 911 08 |
| 18 | 10 | 911 10 |

Carbide Dead Centers DIN 807



type with extraction screw thread for hardened workpieces

With extraction screw thread

Dead centers according to DIN 807 are designed with an extraction thread. This serves to protect the spindle bearings and is necessary for use in non-drilled sleeves.

Type DIN 807 · model E



with full carbide tip



0.002



Type DIN 807 · model HE



flattened with half carbide tip



0.002



with half carbide tip



- Run-out deviation max.: 0.002 mm.
- With carbide insert.
- Max. load of the dead centers upon request.
- Special design upon request.
- For demounting and for preventing the spindle bearing from damage of for spindle sleeves which have no through bore the center pins come with an extracting screw thread.
- Extracting nuts, see page 118 - 119 for accessories.
- Available with wrench flat upon request.

Technische Daten - Typ DIN 807 · Form E/HE



similar to DIN 807 · model E
with full carbide tip

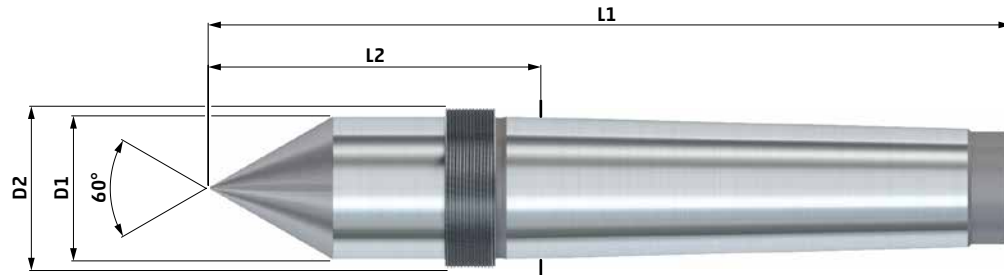

model E
with half carbide tip

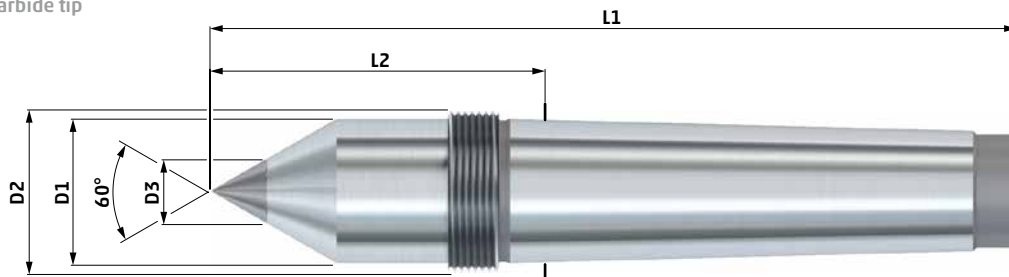

model HE
flattened with
half carbide tip

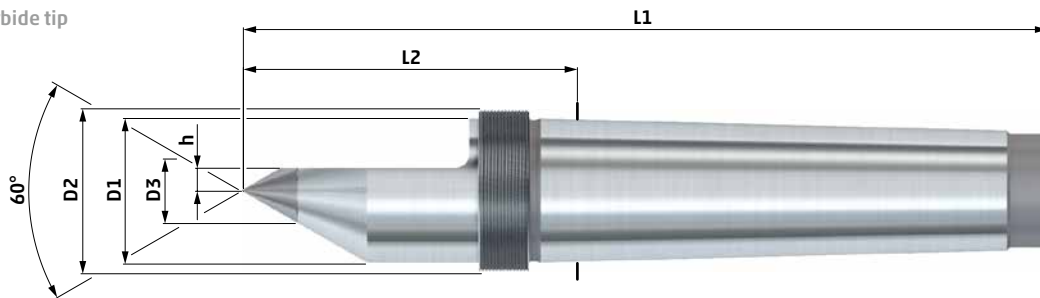

MODEL E



MODEL HE



| MK | D1 | D2 | L1 | L2 |
|----|------|-----------|-----|------|
| 1 | 12.2 | M16 x 1.5 | 90 | 36.5 |
| 2 | 18 | M22 x 1.5 | 112 | 48 |
| 3 | 24.1 | M27 x 1.5 | 138 | 57 |
| 4 | 31.6 | M36 x 1.5 | 175 | 72.5 |
| 5 | 44.7 | M48 x 1.5 | 217 | 87.5 |
| 6 | 63.8 | M68 x 1.5 | 290 | 108 |

cat. no.

912 02
912 05
912 08
912 11
912 14
912 18

D3

cat. no.

7 **912 01**
7 **912 03**
11 **912 06**
14 **912 09**
18 **912 12**
18 **912 15**

D3

h

cat. no.

7 1.5 **913 01**
7 2 **913 03**
11 3 **913 06**
14 5 **913 09**
18 7 **913 12**
18 10 **913 15**

Changeable Center Cones for type RNA / FNA

center cones for large workpiece centers

High degree of flexibility for clamping of workpieces with large centers.

For type RNA / FNA with SK30 interface



Technical data - for type RNA / FNA with SK30 interface

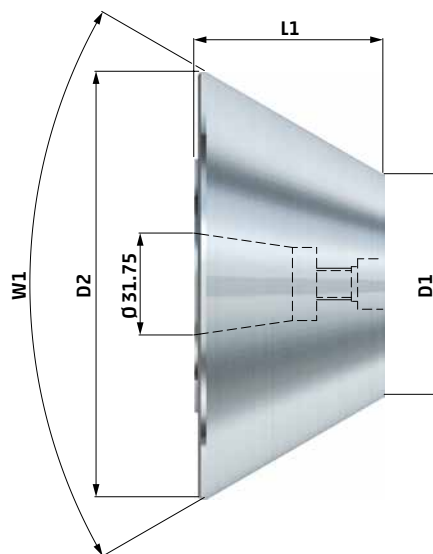

- Suitable for live centers type RNA on page 86 - 87 and for dead centers type FNA on page 108 - 109.
- Special cones up to \varnothing 400 available upon customer's request.
- The center cones are fastened with a screw M8 DIN 912 onto the base body.
- The center cones can be drawn off with a screw M10.

FOR TYPE RNA / FNA

| W1 | D1 | D2 | L | cat. no. |
|----|-----|-----|----|---------------|
| 60 | 20 | 85 | 60 | 814 50 |
| 60 | 70 | 135 | 60 | 814 51 |
| 60 | 120 | 185 | 60 | 814 52 |
| 60 | 170 | 235 | 60 | 814 53 |
| 60 | 220 | 285 | 60 | 814 54 |
| 75 | 20 | 105 | 60 | 814 55 |
| 75 | 90 | 175 | 60 | 814 56 |
| 75 | 160 | 245 | 60 | 814 57 |
| 75 | 230 | 315 | 60 | 814 58 |
| 90 | 20 | 130 | 60 | 814 59 |
| 90 | 100 | 210 | 60 | 814 60 |
| 90 | 180 | 290 | 60 | 814 61 |

Changeable Inserts for type RNW / FNW

Changeable inserts for a maximum of flexibility

The adaptation of various changeable inserts ensures a high degree of flexibility and saving of costs.

For type RNW / FNW with taper interface

model B



model G



- Suitable for live centers type RNW on page 90 - 91 and for the dead centers type FNW on page 108 - 109.
- Special inserts available upon customer's request.
- For quick demounting all changeable inserts come with spanner flat or cross hole.

FOR TYPE RNW3 / 4 FNW MK3 / MK4

| model | D1 | D2 | D3 | D4 | L | cat. no. |
|----------|----|----|----|----|----|---------------|
| A | 22 | - | - | 16 | 30 | 815 50 |
| B | 22 | 10 | - | 16 | 40 | 815 51 |
| C | 22 | 7 | 10 | 16 | 30 | 815 52 |
| D | 22 | 11 | - | 16 | 30 | 815 53 |
| E | 55 | 21 | - | 16 | 35 | 815 54 |
| F | 55 | 50 | 10 | 16 | 30 | 815 55 |
| G | 22 | 10 | - | 16 | 40 | 815 56 |

FOR TYPE RNW5 / 6 FNW MK5 / MK6

| model | D1 | D2 | D3 | D4 | L | cat. no. |
|----------|----|----|----|----|----|---------------|
| A | 34 | - | - | 22 | 35 | 815 60 |
| B | 34 | 16 | - | 22 | 45 | 815 61 |
| C | 34 | 10 | 7 | 22 | 29 | 815 62 |
| D | 34 | 18 | - | 22 | 35 | 815 63 |
| E | 70 | 33 | - | 22 | 38 | 815 64 |
| F | 70 | 64 | 24 | 22 | 34 | 815 65 |
| G | 34 | 16 | - | 22 | 45 | 815 66 |

Technical data - for type RNW / FNW with taper interface

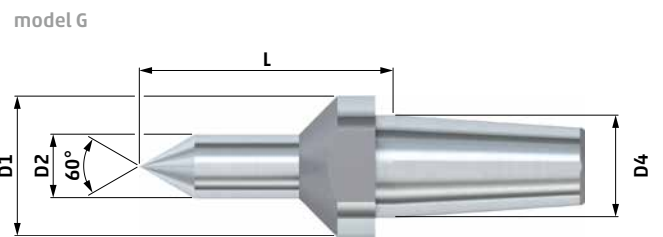
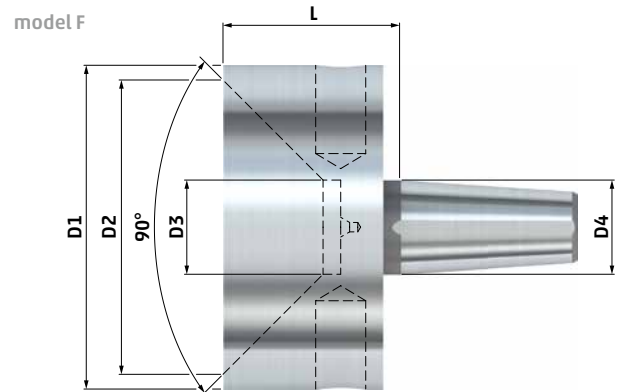
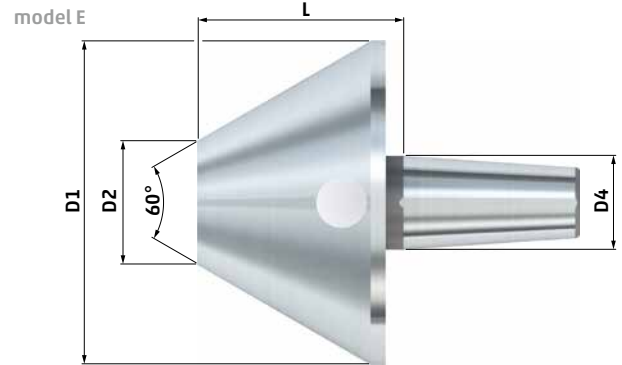
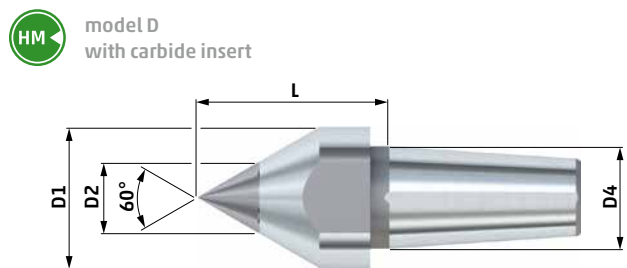
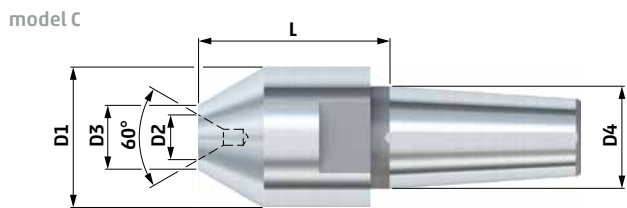
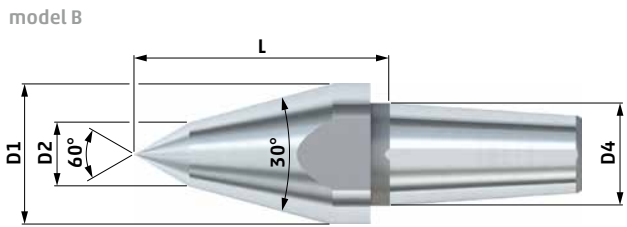
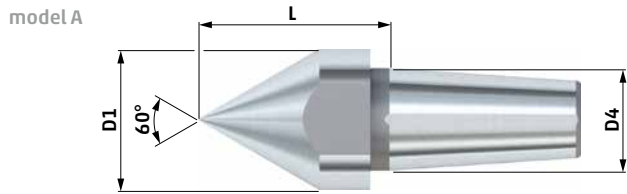

Extracting nut DIN 1804 h

Type DIN 1804 h



Technical data - type DIN 1804 h

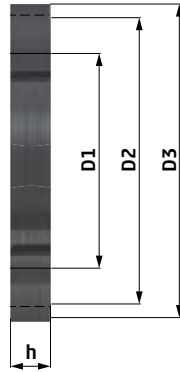

for ultra live centers, center pins and face driver

| D1 | D2 | D3 | h | cat. no. |
|-----------|----|----|----|---------------|
| M28 x 1.5 | 43 | 50 | 10 | 830 39 |
| M32 x 1.5 | 45 | 52 | 11 | 830 40 |
| M35 x 1.5 | 47 | 55 | 11 | 830 41 |
| M36 x 1.5 | 48 | 55 | 11 | 830 42 |
| M48 x 1.5 | 67 | 75 | 13 | 830 43 |

| D1 | D2 | D3 | h | cat. no. |
|-----------|-----|-----|----|---------------|
| M58 x 1.5 | 80 | 90 | 13 | 830 22 |
| M70 x 1.5 | 90 | 100 | 14 | 830 44 |
| M75 x 1.5 | 100 | 110 | 14 | 830 23 |
| M95 x 2 | 120 | 135 | 16 | 830 24 |
| M110 x 2 | 140 | 155 | 16 | 830 25 |

Extracting nut DIN 807

Type DIN 807



Technical data - type DIN 807

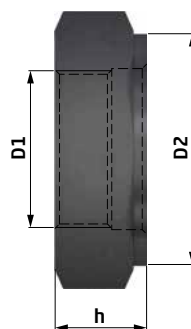

for dead centers and center pins

| MK | D1 | D2 | h | s | cat. no. |
|----------|-----------|----|-----|------|---------------|
| 1 | M16 x 1.5 | 23 | 24 | 12 | 929 99 |
| 2 | M22 x 1.5 | 30 | 32 | 15.5 | 930 00 |
| 3 | M27 x 1.5 | 39 | 41 | 17.5 | 930 01 |
| 4 | M36 x 1.5 | 53 | 55 | 21 | 930 02 |
| 5 | M48 x 1.5 | 67 | 75 | 23 | 930 03 |
| 6 | M68 x 1.5 | 90 | 100 | 25.5 | 930 04 |

Taper Cleaner / Cone Wiper

for cleaning an inner Morse taper
(e. g. work spindle or tailstock)

Taper cleaner / cone wiper



| MK | cat. no. |
|----|----------|
| 1 | 500 31 |
| 2 | 500 32 |
| 3 | 500 33 |
| 4 | 500 34 |
| 5 | 500 35 |
| 6 | 500 36 |

Installation- / Removal Paste

Universal use as installation paste and for preventing fretting corrosion

Castrol Optimol Paste White T is ideal for all installation work as well as for base-film and thin-film lubrication. The paste prevents fretting rust as well as facilitating installation and removal of our clamping tools.

It is resilient to hot and cold water and provides anti-corrosion protection.

Installation- / removal paste

white, virtually colourless when applied as a thin film

cat. no.

500 40

