



NT TOOL CATALOGO No.2

Ver. Esp. 20190416



NT TOOL DE MEXICO S.A. DE C.V.



SEDE CENTRAL - HEAD OFFICE



FÁBRICA IIDA - IIDA FACTORY



OFICINA/FÁBRICA DE TAILANDIA - THAILAND OFFICE/FACTORY



OFICINA/FÁBRICA DE INDONESIA - INDONESIA OFFICE/FACTORY



OFICINA DE MÉXICO - MEXICO OFFICE

Expanding and connecting a través de nuestra red global NT TOOL

Expanding and connecting

- NT Tool's global network -

Adicionalmente a nuestra sede central en la ciudad de Takahama en Aichi, Japón, hemos desplegado bases de operación en Tokyo, Osaka, Hiroshima e Iida. Fuera de Japón, hemos establecido centros de ventas en E.U.A., Alemania, China, Tailandia e Indonesia. Hemos expandido nuevas vías de comunicación con nuestros clientes en más de 30 países y continuaremos extendiendo nuestra red NT TOOL para continuar atendiendo la demanda creciente del mercado a nivel mundial.

In addition to our headquarter in the city of Takahama in Aichi, Japan, we have rolled out domestic bases in Tokyo, Osaka, Hiroshima, and Iida. Outside of Japan, we have established sales centers in the USA, Germany, China, Thailand, and Indonesia. We broadened our communication link to customers in over 30 countries around the world. We will continue expanding the NT Tool network to meet rising worldwide demand in the manufacturing industry.

NT TOOL CORPORATION

NT TOOL DE MEXICO S.A. DE C.V. (OFICINA - OFFICE)

Bldv. Aeropuerto No. 648, Local 5, Col. San José el Alto, León, Guanajuato, México C.P. 37545

Tel. 52-477-194-4585

E-mail: sales@nttool.com.mx

SEDE CENTRAL OFICINA/FÁBRICA - HEAD OFFICE/FACTORY

1-7-10, Yoshikawa-cho, Takahama-City, Aichi, 444-1386 Japón

Tel.81-(0)566-54-0101 Fax.81-(0)566-54-0111

www.nttool.com E-mail: osb@nttool.co.jp

OFICINA DE TOKYO - TOKYO OFFICE

Tel.81-(0)3-3451-9141 Fax.81-(0)3-3451-9085

OFICINA DE OSAKA - OSAKA OFFICE

Tel.81-(0)6-6308-1332 Fax.81-(0)6-6302-0653

OFICINA DE HIROSHIMA - HIROSHIMA OFFICE

Tel.81-(0)82-258-3810 Fax.81-(0)82-258-3811

FÁBRICA DE IIDA - IIDA FACTORY

Tel.81-(0)265-25-5200 Fax.81-(0)265-25-5225

OFICINA DE EUROPA - EUROPE OFFICE

Tel.49-(0)6171-91639-0 Fax.49-(0)6171-91639-90

OFICINA DE CHINA - CHINA OFFICE

Tel.86-(0)21-6361-9540 Fax.86-(0)21-6360-7845

NT TOOL (TAILANDIA) CO.,LTD. (OFICINA/FÁBRICA)

NT TOOL (THAILAND) CO., LTD. (OFFICE/FACTORY)

222 Moo 1, Hi-tech Industrial Estate, Banpho, Bang Pa-in,

Ayuthaya 13160, Thailand

Tel.66-(0)3531-4180 Fax.66-(0)3531-4182

E-mail: nt_thai@ksc.th.com]

PT. INDONESIA (OFICINA/FÁBRICA)

PT. INDONESIA (OFFICE / FACTORY)

Jl. Mitra Raya II Blok E No.3, Kaw. Industri Mitrakarawang

Parungmulya, Ciampel, Karawang, Jawa Barat, 41361, Indonesia

Tel. 62-267-863-1711 Fax. 62-267-863-1712

E-mail: nt-indonesia@nttool.co.jp

Tabla de conversión para sistema pulgada / métrico

Inch / Metric Conversion Table

Métrico Metric	Pulgadas inch	Métrico Metric	Pulgadas inch
45	1.772	200	7.874
50	1.969	205	8.071
55	2.165	210	8.268
60	2.362	215	8.465
65	2.559	220	8.661
70	2.756	225	8.858
75	2.953	230	9.055
80	3.15	235	9.252
85	3.346	240	9.449
90	3.543	245	9.646
95	3.74	250	9.843
100	3.937	255	10.039
105	4.134		
110	4.331		
115	4.528		
120	4.724		
125	4.921		
130	5.118		
135	5.315		
140	5.512		
145	5.709		
150	5.906		
155	6.102		
160	6.299		
165	6.496		
170	6.693		
175	6.89		
180	7.087		
185	7.283		
190	7.48		
195	7.677		

Referencia para longitud de proyección
Projection length reference / conversion table

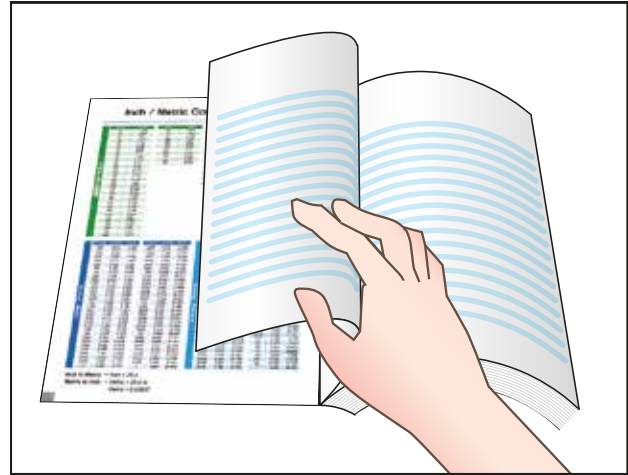

Por favor utilice estas tablas para convertir de sistema métrico ↔ pulgada.

Please use these tables to convert metric ↔ inch.

Fracción Fraction	Decimal Decimal	Métrico Metric	Fracción Fraction	Decimal Decimal	Métrico Metric
1/64	0.015	0.396	33/64	0.515	13.096
1/32	0.031	0.793	17/32	0.531	13.493
3/64	0.046	1.191	35/64	0.546	13.891
1/16	0.062	1.587	9/16	0.562	14.287
5/64	0.078	1.981	37/64	0.578	14.684
3/32	0.093	2.381	19/32	0.593	15.081
7/64	0.109	2.778	39/64	0.609	15.478
1/8	0.125	3.175	5/8	0.625	15.875
9/64	0.140	3.571	41/64	0.640	16.271
5/32	0.156	3.968	21/32	0.656	16.668
11/64	0.171	4.366	43/64	0.671	17.066
3/16	0.187	4.762	11/16	0.687	17.462
13/64	0.203	5.159	45/64	0.703	17.859
7/32	0.218	5.556	23/32	0.718	18.256
15/64	0.234	5.953	47/64	0.734	18.653
1/4	0.250	6.350	3/4	0.750	19.050
17/64	0.265	6.746	49/64	0.765	19.446
9/32	0.281	7.143	25/32	0.781	19.843
19/64	0.296	7.540	51/64	0.796	20.240
5/16	0.312	7.937	13/16	0.812	20.637
21/64	0.328	8.334	53/64	0.828	21.034
11/32	0.343	8.731	27/32	0.843	21.431
23/64	0.359	9.128	55/64	0.859	21.828
3/8	0.375	9.525	7/8	0.875	22.225
25/64	0.390	9.921	57/64	0.890	22.621
13/32	0.406	10.318	29/32	0.906	23.018
27/64	0.421	10.716	59/64	0.921	23.416
7/16	0.437	11.112	15/16	0.937	23.812
29/64	0.453	11.509	61/64	0.953	24.209
15/32	0.468	11.906	31/32	0.968	24.606
31/64	0.484	12.303	63/64	0.984	25.003
1/2	0.500	12.700	1	1.000	25.400

Clasificado por el sistema métrico/decimal
Sorted by Metric/Decimal

Fracción Fraction	Decimal Decimal	Métrico Metric	Fracción Fraction	Decimal Decimal	Métrico Metric
1/64	0.015	0.396	1/32	0.031	0.793
3/64	0.046	1.191	3/32	0.093	2.381
5/64	0.078	1.981	5/32	0.156	3.968
7/64	0.109	2.778	7/32	0.218	5.556
9/64	0.140	3.571	9/32	0.281	7.143
11/64	0.171	4.366	11/32	0.343	8.731
13/64	0.203	5.159	13/32	0.406	10.318
15/64	0.234	5.953	15/32	0.468	11.906
17/64	0.265	6.746	17/32	0.531	13.493
19/64	0.296	7.540	19/32	0.593	15.081
21/64	0.328	8.334	21/32	0.656	16.668
23/64	0.359	9.128	23/32	0.718	18.256
25/64	0.390	9.921	25/32	0.781	19.843
27/64	0.421	10.716	27/32	0.843	21.431
29/64	0.453	11.509	29/32	0.906	23.018
31/64	0.484	12.303	31/32	0.968	24.606
33/64	0.515	13.096	1/16	0.062	1.587
35/64	0.546	13.891	3/16	0.187	4.762
37/64	0.578	14.684	5/16	0.312	7.937
39/64	0.609	15.478	7/16	0.437	11.112
41/64	0.640	16.271	9/16	0.562	14.287
43/64	0.671	17.066	11/16	0.687	17.462
45/64	0.703	17.859	13/16	0.812	20.637
47/64	0.734	18.653	15/16	0.937	23.812
49/64	0.765	19.446	1/8	0.125	3.175
51/64	0.796	20.240	3/8	0.375	9.525
53/64	0.828	21.034	5/8	0.625	15.875
55/64	0.859	21.828	7/8	0.875	22.225
57/64	0.890	22.621	1/4	0.250	6.350
59/64	0.921	23.416	3/4	0.750	19.050
61/64	0.953	24.209	1/2	0.500	12.700
63/64	0.984	25.003	1	1.000	25.400

Clasificado por el sistema en fracción
Sorted by Fraction group

Pulgada a métrico → Pulgada × 25.4

Métrico a pulgada → Métrico ÷ 25.4 ó Métrico × 0.03937

Inch to Metric → Inch × 25.4

Metric to Inch → Metric ÷ 25.4 or Metric × 0.03937

Instrucciones de seguridad - Safety Instructions

Por su propia seguridad - For your own safety

Gracias por utilizar productos NT TOOL. En NT TOOL continuamos esforzándonos para mejorar la calidad y seguridad de nuestros productos. Antes de utilizar los productos que se muestran en este catálogo, le recomendamos leer cuidadosamente las siguientes instrucciones.

Thank you for using NT products. NT continues making every effort to improve the quality and safety of our products. We recommend you to read the following instructions carefully before using the products shown in this catalog.



Indica condiciones/situaciones de riesgo que en caso de no ser seguidas al pie de la letra pueden resultar en un gran riesgo. Se le pide leer y buscar  en nuestros manuales de instrucciones para evitar lesiones o daño a la propiedad.

Indicates hazardous conditions that, if not faithfully followed, could result in a great danger. You are requested to read and follow  in our instruction manuals without fail to avoid personal injury or property damage.

Manejo - Handling

- Se debe tener cuidado al manejar o desempacar los productos ya que podrían caer accidentalmente o resbalarse fuera del empaque.
- Se debe tener cuidado al transportar o cargar portaherramientas pesados. En caso de ser necesario, deberá de utilizarse equipo de montacargas.
- Un portaherramientas no debe ser utilizado como unidad de calibración para producir husillos.
- Care must be taken when handling or unpacking products as they may accidentally drop or slip out of the packaging.
- Care must be taken when carrying or transporting heavy holders. Where necessary, lifting equipment should be used.
- A tool holder must not be used as a taper guage to produce machine spindles.

Colocando y retirando una herramienta de corte - Attaching and removing a cutting tool

- Al cambiar las herramientas de corte, el portaherramienta debe ser asegurado firmemente en un sistema de sujeción.
- Si no cuenta con protección en las manos, no tocar las herramientas de corte. Se deben usar guantes de protección.
- Utilice siempre la llave Allen o llave de torque recomendada al ajustar el portaherramientas. Nunca utilice un martillo o extensión para incrementar la fuerza del torque.
- Tool holders must be firmly secured in clamping device when changing cutting tools.
- Do not touch cutting tools with unprotected hands. Gloves should be used for protection.
- Always use the recommended wrench or spanner when tightening a chuck. Never use a hammer or extension to increase tightening torque.

Durante la operación de maquinado - During machining operation

- No coloque las manos cerca de herramientas en rotación. Esto podría resultar en lesiones serias.
- Las virutas de metal caliente pueden ser proyectadas desde la pieza de trabajo durante el maquinado. Por lo tanto, las máquinas deben estar totalmente selladas y el operador deberá utilizar equipo de protección cada vez que opere la máquina.
- Si la preparación se hace con uso de refrigerante de alta presión, no se acerque al borde de corte de la herramienta. El cortador podría ser expulsado y causar lesiones en el personal.
- Los portaherramientas y otras herramientas deben ser utilizadas para lo que están destinadas y no deben ser modificadas o desarmadas. Esto podría causar lesiones accidentales en el personal.
- Do not place hands near a rotating tool. This can result in a serious injury.
- Hot metal chips may be projected from the workpiece during machining. Machines should therefore be fully guarded and the operator should use protective equipment at all times.
- If set up is made with high pressure coolant in use, do not approach the cutting edge. The cutter may be ejected and cause personal injury.
- Holders and other tools should be used as intended and should not be modified or disassembled. This can cause accidental injury.

Cuidado de los productos - Care of products

- Las herramientas de corte deben ser removidas del portaherramientas cuando no vayan a ser usadas por largos periodos de tiempo. Al no realizar esta acción, podría resultar en pérdida de la fuerza de sujeción. Después de largos periodos en almacenamiento, el anillo de sujeción de la rosca/tapa siempre debe ser aflojado y re-ajustado antes de comenzar con la operación de maquinado.
- Todos los portaherramientas deben ser limpiados a fondo y protegidos con aceite a prueba de óxido antes de ser colocados en almacenaje. Se debe tener cuidado de no dañar la superficie del zanco del portaherramienta.
- Tools should be removed from the chucks when not in use for long periods of time. Failure to do so may result in reduced clamping force. After long periods in storage the cap/clamping ring should always be loosened and re-tightened before starting machining operation.
- All holders should be thoroughly cleaned and protected with rust proof oil before being placed in storage. Care should be taken to avoid damaging the contact surface of the taper.

Estas son advertencias generales de seguridad y cada producto tiene instrucciones de seguridad específicas las cuales deben seguirse antes de su uso. Por favor contactar a NT en caso de tener alguna pregunta.

These are general safety warnings and each product has specific safety instructions which should be followed before use. Please contact NT if you have any questions.











Tabla de contenidos

Table Of Contents

<p>PHC·A Power Hydro Chuck</p>  <p>Característica - Feature 034 BT 108 CAT 211 AHO 260 HSK·A 320 HSK·E 366 HSK·F 372 UTS 428</p>	<p>PHC·S Slim Hydro Chuck</p>  <p>Característica - Feature 036 CAT 217</p>	<p>PHC·SA Slim Hydro Chuck</p>  <p>Característica - Feature 029 BT 118 AHO 264 HSK·A 325 UTS 430</p> <p style="text-align: right;">Nuevo New</p>															
<p>PHC·SA-C Slim Hydro Chuck</p>  <p>Característica - Feature 030 BT 115 AHO 262 HSK·A 323 UTS 429</p> <p style="text-align: right;">Nuevo New</p>	<p>PHC·H Hydro Chuck Omega (Milling/ Fresado)</p>  <p>Característica - Feature 032 BT 122 CAT 219 AHO 268 HSK·A 329 UTS 434</p>	<p>CT·SA Super Tite-Lock Milling Chuck</p>  <p>Característica - Feature 041 CT·SA BT 064 CAT 198 AHO 250 HSK·A 298 UTS 416 NT 068</p>															
<p>CT·SA-CF Super Tite Lock Milling Chuck (Flange Through Type)</p>  <p>Característica - Feature 041 BT 066</p>	<p>HDC·A High-Precision Collet Holder High-Precision Collet Holder HDC·A-CF (Flange Through Type)</p>  <table border="0" style="width: 100%;"> <tr> <td style="width: 50%;">HDC·A</td> <td style="width: 50%;">HDC·A-CF</td> </tr> <tr> <td>Característica - Feature 044</td> <td>Característica - Feature -</td> </tr> <tr> <td>BT 074</td> <td>BT 076</td> </tr> <tr> <td>CAT 200</td> <td></td> </tr> <tr> <td>AHO 252</td> <td>HSK·F 372</td> </tr> <tr> <td>HSK·A 302</td> <td>UTS 418</td> </tr> <tr> <td>HSK·E 366</td> <td>ST 085</td> </tr> </table>		HDC·A	HDC·A-CF	Característica - Feature 044	Característica - Feature -	BT 074	BT 076	CAT 200		AHO 252	HSK·F 372	HSK·A 302	UTS 418	HSK·E 366	ST 085	
HDC·A	HDC·A-CF																
Característica - Feature 044	Característica - Feature -																
BT 074	BT 076																
CAT 200																	
AHO 252	HSK·F 372																
HSK·A 302	UTS 418																
HSK·E 366	ST 085																
<p>SDM Drill Holder With Easy Tool Length Adjustment</p>  <p>Característica - Feature 042 BT 078 CAT 202 AHO 254 HSK·A 304 UTS 420</p>	<p>ERC Collet Holder for Small Diameter, Collet Holder For Small Diameters ERC-T (Taper Type)</p>  <table border="0" style="width: 100%;"> <tr> <td style="width: 33%;">ERC</td> <td style="width: 33%;">ERC-T</td> <td style="width: 33%;"></td> </tr> <tr> <td>BT 081</td> <td>HSK·F 373</td> <td>BT 084</td> </tr> <tr> <td>CAT 205</td> <td>UTS 422</td> <td>HSK·A 310</td> </tr> <tr> <td>HSK·A 308</td> <td>ST 088</td> <td>UTS 423</td> </tr> <tr> <td>HSK·E 368</td> <td></td> <td></td> </tr> </table>		ERC	ERC-T		BT 081	HSK·F 373	BT 084	CAT 205	UTS 422	HSK·A 310	HSK·A 308	ST 088	UTS 423	HSK·E 368		
ERC	ERC-T																
BT 081	HSK·F 373	BT 084															
CAT 205	UTS 422	HSK·A 310															
HSK·A 308	ST 088	UTS 423															
HSK·E 368																	
<p>GDC·A High-Precision Collet Holder (High-Balanced Type)</p>  <p>Característica - Feature 044 BT 080 CAT 204 HSK·A 306</p>	<p>CTZ·SA "R"Zero Holder for Large Diameter</p>  <p>Característica - Feature 038 BT 102 CAT 209 AHO 258 HSK·A 314 UTS 426</p>	<p>HDZ "R"Zero Holder</p>  <p>Característica - Feature 039 BT 100 CAT 207 AHO 256 HSK·A 312 UTS 312 ST 086</p>															
<p>GDZ "R"Zero Holder (High-Balanced Type)</p>  <p>Característica - Feature 039 BT 104 HSK·A 315</p>	<p>ERZ "R"Zero Holder For Small Diameters</p>  <p>Característica - Feature 039 BT 106 HSK·A 317 UTS 427</p>	<p>PHZ·S Slim Hydro "R" Zero Holder</p>  <p>Característica - Feature 040 BT 107 CAT 210 HSK·A 318</p>															

STM	Synchronous Tap Holder With Easy Tool Length Adjustment	SMH	Synchronous Tap Holder With Easy Tool Length Adjustment	STP	Synchro Tapping Chuck
	Característica - Feature 043 BT 134 CAT 224 AHO 274 HSK·A 340 UTS 418		Característica - Feature 026 Zanco recto 131 BT 132 HSK·A 338		BT 140
TP1	Quick Change Tapping Chuck	TP3B	Quick Change Tapping Chuck (Auto Depth Control)	BT30-SBV SBH, TSB	Turning Tools for brother's SPEEDIO M140X1
	BT 141 CAT 229 HSK·A 347		BT 143		Característica - Feature 054 SBV 181 SBH 188 TSB 385
HSK·T	HSK·T Herramientas de torneado / HSK·T Turning Tools	AHS, AHL	Angle Heads (Flexible Type) 0-90°	AHSE AHLE	Angle Heads (Flexible Type) 0-90°
	Característica - Feature 055 SBV 381 SBN 382 SBH 383 SBT 384 TSB 385 TSD 387		Característica - Feature 048 AHS, AHL BT 174		AHSE, AHLE 048 CAT 242 HSK·A 365
AH**90 AHE**90	Angle Heads (Fixed Type) 90°	AH**45	Angle Heads (Fixed Type) 45°	HP-H	Hyper Spindle (Speed Increaser)
	Característica - Feature 048 AH90 BT 170 AHO 292 AHE90 CAT 240 HSK·A 263		Característica - Feature 048 AH45 BT 172 AHO 294		Característica - Feature 049 BT 169 CAT 239
***-CS Coolant Holder			MDE NT-MEVIOUS		
	HDC·A-CS BT 176 CAT 244 CT·SA-CS BT 177 CAT 245	CT·A-CS BT 178 HC-CS BT 179 TP-CS BT 180	MT-CS BT 182 SL-CS BT 183		Característica - Feature 060 MDE CAT 246
KHE/BT	BT Shank For Stub Holder	KLD	Keyless Drill Chuck		
	BT 166		BT 168 CAT 238 HSK·A 362		

SRD Shrink Fit (DIN Standard)		SRK Shrink Fit (Heavy Type)		SCA Side Cutter Arbor																													
 <p>Característica - Feature 053 BT 124 CAT 220 AHO 270 HSK-A 332 HSK-E 370</p>		 <p>Característica - Feature 053 BT 130 HSK-A 330 UTS 436</p>		 <p>BT 161 CAT 234 AHO 290 HSK-A 358</p>																													
SRS Shrink Fit (Slim Type)		JTA Jacobs Taper Arbor		C Polygon Taper Shank System																													
 <p>Característica - Feature 053 BT 128 CAT 222 AHO 272 HSK-A 336 HSK-E 371 UTS 437</p>		 <p>BT 163 CAT 236</p>		 <p>HDC-A 390 TSB 392 TSD 393</p> <p style="color: red; border: 1px solid red; border-radius: 50%; padding: 2px; display: inline-block;">Nuevo New</p>																													
SM1, SMA SMB, SMC Shell End Mill Arbor			MTA MTB Morse Taper Holder																														
 <p>SM1 BT 155 SMA BT 157 SMB BT 159 SMC BT 160</p>			 <p>MTA BT 164 CAT 237 AHO 280 HSK-A 359 MTB BT 165</p>																														
FMH·A, FMA·A FMB·A, FMC·A Face Mill Arbor																																	
 <table style="width: 100%; border-collapse: collapse;"> <thead> <tr> <th style="text-align: left;">FMH·A</th> <th style="text-align: left;">FMA·A</th> <th style="text-align: left;">FMB·A</th> <th style="text-align: left;">FMC·A</th> </tr> </thead> <tbody> <tr> <td>BT 151</td> <td>BT 153</td> <td>BT 154</td> <td>BT 155</td> </tr> <tr> <td>AHO 282</td> <td>CAT 233</td> <td>AHO 286</td> <td>AHO 288</td> </tr> <tr> <td>HSK-A 353</td> <td>AHO 284</td> <td>HSK-A 356</td> <td>HSK-A 357</td> </tr> <tr> <td>UTS 445</td> <td>HSK-A 355</td> <td></td> <td></td> </tr> <tr> <td></td> <td>UTS 447</td> <td></td> <td></td> </tr> </tbody> </table>						FMH·A	FMA·A	FMB·A	FMC·A	BT 151	BT 153	BT 154	BT 155	AHO 282	CAT 233	AHO 286	AHO 288	HSK-A 353	AHO 284	HSK-A 356	HSK-A 357	UTS 445	HSK-A 355				UTS 447						
FMH·A	FMA·A	FMB·A	FMC·A																														
BT 151	BT 153	BT 154	BT 155																														
AHO 282	CAT 233	AHO 286	AHO 288																														
HSK-A 353	AHO 284	HSK-A 356	HSK-A 357																														
UTS 445	HSK-A 355																																
	UTS 447																																
SLA, SL2, SLB, SLD Side Lock Holder																																	
 <table style="width: 100%; border-collapse: collapse;"> <thead> <tr> <th style="text-align: left;">SLA</th> <th style="text-align: left;">SL2</th> <th style="text-align: left;">SLH</th> <th style="text-align: left;">SLD</th> </tr> </thead> <tbody> <tr> <td>BT 148</td> <td>BT 147</td> <td>BT 145</td> <td>BT 150</td> </tr> <tr> <td>HSK-A 350</td> <td>CAT 231</td> <td>CAT 231</td> <td>HSK-A 352</td> </tr> <tr> <td></td> <td>AHO 281</td> <td>AHO</td> <td></td> </tr> <tr> <td></td> <td>HSK-A 351</td> <td>HSK-A 348</td> <td></td> </tr> <tr> <td></td> <td>SLB</td> <td></td> <td></td> </tr> <tr> <td></td> <td>BT 150</td> <td></td> <td></td> </tr> </tbody> </table>						SLA	SL2	SLH	SLD	BT 148	BT 147	BT 145	BT 150	HSK-A 350	CAT 231	CAT 231	HSK-A 352		AHO 281	AHO			HSK-A 351	HSK-A 348			SLB				BT 150		
SLA	SL2	SLH	SLD																														
BT 148	BT 147	BT 145	BT 150																														
HSK-A 350	CAT 231	CAT 231	HSK-A 352																														
	AHO 281	AHO																															
	HSK-A 351	HSK-A 348																															
	SLB																																
	BT 150																																

PSB	Retention Stub	Boquilla Collet		Dimensiones del zanco Shank Dimension	
	<p>PSB(BT) 190 PSB(AHO) 296 PSC(CAT) 247</p>		<p>PHS 114 FDC 090 FDC-OH 091 FDC-C 092 FDC-MS 093 EDC 467 ER 094 EMS 502 FSC 138 FSC-MS 139</p>	<p>BT 194 NT 194 JBS 195 HSK 378</p>	
KH-E	Q.C Stub Holder	KH-EC	Q.C Stub Holder with Oil Hole	KH-A, KH KH-A-NL	Q.C Stub Holder
	<p>KH-E 451</p>		<p>KH-EC1 454 KH-EC2 455</p>		<p>KH-A 458 KH 461 KH-A-NL 460</p>
KTP, KTL KTL P	Q.C Stub Holder	WE, WES·B WEN, WESN·B	Q.C Tap Adapter	FH-**	Floating Holder
	<p>KTP 473 KTL 474 KTL P 475</p>		<p>WE 480 WES·B 481 WEN 482 WESN·B 483 WEC 484 WENC 485</p>		<p>FH-Tr 515 FH-MT 516 FH-ST 517 FH-ST-HDC·A 519</p>
Adaptador ajustable Adjustable Adapter		EM·A	Endmill Chuck	DC*, ED*	Straight Drill Chuck
	<p>D 492 F 494 H 496 M 496 N 497 T 498</p>		<p>EM·A 502</p>		<p>DC 506 DC-T,N 507 ED·A 509 ED 511</p>

ISG3400	Shrink Fit System	SRK-HA1 SRK-HB2	Economy Type Heater		
	Característica Feature 042 ISG3400 524		Característica Feature 042 SRK-HA1 528 SRK-HB2 528		
AOTP	Contactless Optical Tool Presetter	SOTP	Contactless Optical Tool Presetter		
	Característica Feature 046 AOTP 530		Característica Feature 048 SOTP 534		
SPN1-HSK HCL	HSK Clamper	SPZ-2	"R" Zero Setter	SPHV-3	Simple Setter
	Característica Feature 049 SPN1-HSK 538 HCL 539		Característica Feature 049 SPZ-2 540		Característica Feature 049 SPHV-3 541
SP*	Simple Setter (Presetting gauge)	BUSHING		FM	Chamfering Cutter
	SPN2-SRK-PS1 ... 491 SPN 544 SPK-K 548 SPK-KHA 551 SPW 554 SPK-STC 557 SPT 560		A 566 B 568 C 570 D 572 E 574 F 576 G 578		FM 583
BM	Back Chamfering Cutter	BZ	Back Spot-facing Cutter		
	BM 584		BZ 585		
Chamfering Drill		NEW Chamfering Drill		Chamfering Holder	
 587	 588	 589

NOTAS

Índice alfabético

Alphabetic Index

ÍNDICE POR ZANCO SHANK INDEX

BT Series	061 ~ 196
CAT Series	197 ~ 248
AHO Series	249 ~ 296
HSK · A Series	297 ~ 365
HSK · E Series	366 ~ 371
HSK · F Series	372 ~ 374
HSK · T Series	380 ~ 387
C · Series	389 ~ 414
UTS Series	415 ~ 448

A

A	Bushing	566
ADS	Adapter	539
AH, AH-OH (45°)	Angle Heads (Fixed Type)	172
AH, AH-OH (90°)	Angle Heads (Fixed Type)	170
AHE (90°)	Angle Heads (Fixed Type)	240
AHS, AHL	Angle Heads (Flexible Type)	174
AHSE, AHLE	Angle Heads (Flexible Type)	242
AOTP	Contactless Optical Tool Presetter	530
AOTP-DUST-C	Cleaning paste	531
AOTP-PRINT-KG	Label printer for AOTP	531
AOTP-PRINT-LA	Label roll for AOTP-PRINT-KG	531

B

B	Bushing	568
BL	Stopper Bolt	072
BM	Back Chamfering Cutter	584
BR	Bushing	568
BT*-**	Hex. Bit Socket	522
BZ	Back Spot-facing Cutter	585

C

C	Bushing	570
C	Chamfering Holder	589
CL**N.**D	Llave Allen - Torque Wrench	523

CMT	Morse Taper Sleeve	182
CP-NBT**OH	Coolant Pipe	296
CR	Bushing	570
CS	Seal Unit	184
CSL	Sleeve for Side Lock	183
CT · A-CS	CT · A Coolant Inducer	178
CT · SA	Milling Chuck	062
CT · SA-CF	Milling Chuck Flange Through Type	066
CT · SA-CS	CT · S Coolant Inducer	177
CTPS	Preset Driver	180
CTZ · SA	"R" Zero Holder for Large Diameter	102

D

D	Bushing	572
D	Adjustable Adapter	492
DC	Straight Drill Chuck	506
DCS	Preset Driver	508
DR	Bushing	572
DS	Dust Seal	471

E

E	Bushing	574
ED	Straight Drill Chuck For Small Diameters	511
ED · A	Straight Drill Chuck	509
EDC	Boquilla - Collet	467
EM · A	Endmill Chuck	502
EMC	Boquilla - Collet	504
EMP · A	Tuerca - Nut	504
EMS	Boquilla - Collet	504
ER	Bushing	574
ER8	Collet for Small Diameter	094
ERC	Collet Holder for Small Diameter	082
ERC-T	Collet Holder for Small Diameter Taper Type	084
ERZ	"R" Zero Holder for Small Diameter	100
ESC	Collet for Tap	141

F		
FKS03	FKS 3400 Tool Holders	526
FKS3400	FKS Liquid Cooler	526
F	Bushing	576
F	Adjustable Adapter	494
FDC	Boquilla - Collet	090
FDC-C	Coolant Collet	092
FDC-MS	Semidry Collet	093
FDC-OH	Coolant Collet	091
FH-**	Floating Holder	515
FHS	Sleeve	518
FK	Llave de inglesa - Spanner	099
FM	Chamfering Cutter	583
FMA	Face Mill Arbor	153
FMB	Face Mill Arbor	154
FMC	Face Mill Arbor	155
FMH	Face Mill Arbor	151
FR	Bushing	576
FSC-C	Collet For Tap (For Collet through)	138
FSC-MS	High-Precision Collet for Tapper (For Semidry Machining/MQL)	139
FSC-OH	Collet For Tapper (For tool with coolant hole)	138

G		
G	Bushing	578
GDC • A	High Balanced Collet Holder	080
GDP	Nut	080
GDZ	High Balanced "R" Zero Holder	104

H		
H	Adjustable Adapter	496
HC-CS	Hydraulic Chuck Coolant Inducer	179
HCL	Abrazadera HSK - HSK Clamper	539
HDC • A	Collet Holder	074
HDC • A-CF	Collet Holder Flange Through Type	076
HDC • A-CS	HDC • A Coolant Inducer	176
HDMC-G	Coolant Pin Wrench	456

HDP	Tuerca - Nut	074
HDS	Tornillo de preajuste - Preset Screw	081
HDZ	"R" Zero Holder	100
HP-H	Hyper Spindle	169
HS	Llave de inglesa - Spanner	099
HSK-BL	Tornillo de retención - Stopper Bolt	301
HTP	Tuerca - Cap	134

I		
IGB-*	Positioning Block	185 ~ 186
ISG3400	Shrink Fit System	524
ISGS309	Clamping Ring	524
ISGS3200	Induction Coil	524
ISGS3201	Pole Disc One-Piece	524
ISGS3201GT	Pole Disc Two-Piece	524

J		
JA	Jacobs Adapter	073
JAB	Jacobs Adapter	073
JTA	Jacobs Taper Arbor	163

K		
KH	Stub Holder	461
KH-A	Stub Holder	458
KH-A-NL	Stub Tapper	160
KHB	Stub Holder Body	462
KHB-A	Stub Holder Body	459
KHB-E	Stub Holder Body	453
KH-E	Stub Holder	452
KHE/BT	BT Shank for Stub Holder	166
KH-EC	Coolant Stub Holder	154
KH-EC-P	Coolant pin	455
KHS	Unidad preajustada - Preset Driver	463
KLD	Keyless Drill Chuck	168
KTL	Stub Tapper	474
KTLP	Stub Tapper	475

KTP	Stub Tapper	473
------------	-------------	-----

L

LT	Llave Allen (biselado) - Wrench (Chamfering)	584
-----------	--	-----

M

M	Adjustable Adapter	496
MA	Morse Taper Adapter	072
MAB	Morse Taper Adapter	072
MC	Boquilla Recta - Straight Collet	070
MCA	Boquilla Recta - Straight Collet	071
MC-C	Funda de refrigeración por boquilla - Straight Collet	070
MC-OH	Funda de refrigeración por centro de boquilla - Straight Collet	070
MDE	NT Mevius	246
MN5523 · J	MN Flange	376
MS	Master Bar (for Angle Head)	175
MS	Master Arbor (HSK·A)	359
MTA	Morse Taper Holder	164
MTB	Morse Taper Holder	165
MT-CS	Coolant Inducer	182

N

N	Adjustable Adapter	497
----------	--------------------	-----

P

PBK	Base for Presetter	559
PBN	Base for Presetter	547
PBT	Base for Presetter	556
PG	Gauge	549
PHC · A	Hydro Chuck	108
PHC · H	Hydro Chuck	122
PHC · SA	Slim Hydro Chuck	118
PH-HSK	Holder Support	538
PH-K	Holder Support	549
PH-NT	Holder Support	546
PHS	Coller With Stopper Pin	114
PH-STC	Holder Support	558
PH-Tr	Holder Support	561

PH-WE	Holder Support	555
--------------	----------------	-----

PHZ · S	Slim Hydro "R" Zero Holder	107
----------------	----------------------------	-----

PH-KHA	Holder Support	552
---------------	----------------	-----

PS	Gauge Stand	549
-----------	-------------	-----

PSB	Retention Stud	190
------------	----------------	-----

PSB-AHO	Retention Stud for AHO	296
----------------	------------------------	-----

PS-H4	Gauge stand for height gauge	543
--------------	------------------------------	-----

Q

QL**N-ML	Llave Allen - Torque Wrench	522
-----------------	-----------------------------	-----

S

S	Llave de inglesa - Spanner	099
----------	----------------------------	-----

SA	Bushing	566
-----------	---------	-----

SB	Bushing	568
-----------	---------	-----

SBH	Turning Tools for brother's SPEEDIO M140X1	188
------------	--	-----

SBH	HSK · T Turning Tool	383
------------	----------------------	-----

SBN	HSK · T Turning Tool	382
------------	----------------------	-----

SBT	HSK · T Turning Tool	384
------------	----------------------	-----

SBV	Turning Tools for brother's SPEEDIO M140X1	181
------------	--	-----

SBV	HSK · T Turning Tool	381
------------	----------------------	-----

SC	Bushing	570
-----------	---------	-----

SCA	Side Cutter Arbor	161
------------	-------------------	-----

SD	Bushing	572
-----------	---------	-----

SDM	Drill Holder Easy Tool Length Adjustment	078
------------	--	-----

SE	Bushing	574
-----------	---------	-----

SF	Bushing	576
-----------	---------	-----

SH	Cabeza de llave inglesa - Spanner Head	523
-----------	--	-----

SL2	Side Lock Holder	147
------------	------------------	-----

SLA	Side Lock Holder	148
------------	------------------	-----

SLB	Side Lock Holder	149
------------	------------------	-----

SLD	Side Lock Holder	150
------------	------------------	-----

SLH	Side Lock Holder	145
------------	------------------	-----

SL-CS	Coolant Inducer	183
--------------	-----------------	-----

SM1	Shell Endmill Arbor	156
------------	---------------------	-----

SMA	Shell Endmill Arbor	157
------------	---------------------	-----

SMB	Shell Endmill Arbor	159
------------	---------------------	-----

SMC	Shell Endmill Arbor	160
------------	---------------------	-----

SOTP	Contactless Optical Tool Presetter	534
SPHV-3	Simple Setter	541
SPK-K	Simple Setter	548
SPK-KHA	Simple Setter	551
SPK-STC	Simple Setter	557
SPN	Simple Setter	544
SPN1-HSK	HSK Clamper	538
SPN2-SRK*-B*	Presetting Bush	529
SPN2-SRK-PR	Presetting Ring	529
SPN2-SRK-PS1	Presetting gauge	529
SPT	Simple Setter	560
SPW	Simple Setter	554
SPZ-2	"R" Zero Setter	540
SRD	Shrink Fit	124
SRK	Shrink Fit	130
SRK-HA1	Economy Type Heater	528
SRK-HA-HE	Economy Type Heater Hot Air Distributor (Heating Head)	528
SRK-HB2	Economy Type Heater	528
SRK-SP	Holder Support	528
SRS	Shrink Fit	126
STM	Synchronous Tap Holder	134
STP	Tapping Chuck	140
STS	Unidad preajustada - Preset Driver	136
STS-R	Tool for Changing Driver	136

T

T3-W	Tool Holder Air Cooled	525
T3-Z/WZ	Cooling Plate	525
T	Adjustable Adapter	498
T	Tornillo de retención - Lock Screw	579
TP1	Tapping Chuck	142
TP3B	Tapping Chuck	144
TPC	Tapping Chuck	175
TP-CS	Coolant Inducer	180
TSB	Turning Tools for brother's SPEEDIO M140X1	189
TSB	HSK · T Turning Tools	385
TSD	HSK · T Turning Tools	387
TSS	Sleeve for TSB40	386

V

VA662-10	Guantes protectores - Protective Gloves	524
-----------------	---	-----

W

WE	Tap Adapter	480
WEN	Tap Adapter	482
WES · B	Tap Adapter	481
WESN · B	Tap Adapter	483
WEC	Tap Adapter	484
WENC	Tap Adapter	485

Número Number

Ex. : 04-ST	Chamfering Drill	585
Ex. : 07-ST	NEW Chamfering Drill	586

Índice por Categoría de Producto

Index by Product Category

Guía de Selección de Portaherramientas

Holder Selection Guide

Guía de Selección de Portaherramientas / Holder Selection Guide 20

Introducción de Producto

product introduction

Introducción / Introduction	23
Rustproof Tool Holder	25
Omega Hydro Chuck	32
Power Hydro Chuck PHC • A	34
Slim Hydro Chuck PHC • SA	29
Slim Hydro "R" Zero Holder PHZ • S	40
"R" Zero Holder for Large Diameter CTZ • SA	38
Super Tite-lock Milling Chuck CT • SA	41
Collet Holder	44
Drill Holder With Easy Tool Length Adjustment SDM	42
Synchronous Tap Holder With Easy Tool Length Adjustment STM	43
Angle Head	48
Hyper Spindle HP-H	49
Shrink Fit System	53
WBT / NBT AHO Series	50
Turning Tools for SPEEDIO M140X1	54
HSK • T Turning Tools	55
Contactless Optical Tool Presetter AOTP	55
Contactless Optical Tool Presetter SOTP	58
NT MEVIUS	60

BT Series

Milling Chuck

CT • SA	64
CT • SA-CF	66
NT-CT • SA	68
Accesorios / Accessories	70

Collet Holder

HDC • A	74
HDC • A-CF	76
SDM	78
GDC • A	80
ERC	81
ERC-T	84
ST-HDC • A	85
ST-HDZ	86
ST-ERC	88
Accesorios / Accessories	90

"R" Zero Holder

HDZ	100
CTZ • SA	102
GDZ	104
ERZ	106
PHZ • S	107

Hydraulic Chuck

PHC • H	122
PHC • A	108
Accesorios / Accessories	110
PHC • SA-C	115
PHC • SA-NC	116
Accesorios / Accessories	117
PHC • SA	118
Accesorios / Accessories	120

Shrink Fit

SRD	124
SRS	128
SRK	130

Tapping Chuck

SMH	131
STM	134
Accesorios / Accessories	136
STP	140
TP1	142
TP3B	144

Arbors

SLH	145
SL2	147
SLA	148
SLB	149
SLD	150
FMH • A	151
FMA • A	153
FMB • A	154
FMC • A	155
SM1	156
SMA	157
SMB	159
SMC	160
SCA	161
JTA	163

MTA	164
MTB	165
BT Shank for Stub Holder	
KHE/BT	166
Keyless Drill Chuck	
KLD	168
Hyper Spindle	
HP-H	169
Angle Head	
AHS, AHL	174
AH, AH-OH 90°	170
AH, AH-OH 45°	172
Accesorios / Accessories	175
Coolant Inducer	
HDC-A-CS	176
CT-SA-CS	177
CT-A-CS	178
HC-CS	179
TP-CS	180
MT-CS	182
SL-CS	183
Accesorios / Accessories	184
Turning Tools for brother's SPEEDIO M140X1	
SBV	187
SBH	188
TSB	189
Tornillo de Retención / Retention Stub	
PSB	190
Dimensiones del zanco de Herramienta / Tool Shank Dimensions	194

CAT Series	
Milling Chuck	
CT-SA	198
Collet Holder	
HDC-A	200
SDM	202
GDC-A	204
ERC	205
"R" Zero Holder	
HDZ	207
CTZ-SA	209
PHZ-S	210
Hydraulic Chuck	
PHC-H	219

PHC-A	211
Accesorios / Accessories	215
PHC-S	217
Shrink Fit	
SRD	220
SRS	222
Tapping Chuck	
STM	224
FSC	228
TP1	229
STP	230
Arbors	
SLH	231
SL2	232
FMA-A	233
SCA	234
JTA	236
MTA	237
Keyless Drill Chuck	
KLD	238
Hyper Spindle	
HP-H	239
Angle Head	
AHE	240
AHSE, AHLE	242
Coolant Inducer	
HDC-A-CS	244
NT MEVIUS	246
CT-SA-CS	245
Tornillo de Retención / Retention Stub	
PSC	247
Dimensiones del zanco de Herramienta / Tool Shank Dimensions	248

AHO Series	
Milling Chuck	
CT-SA	250
Collet Holder	
HDC-A	252
SDM	254
"R" Zero Holder	
HDZ	256
CTZ-SA	258
Hydraulic Chuck	

PHC•H	268
PHC•A	260
PHC•SA-C	262
PHC•SA-NC	263
PHC•SA	264
Shrink Fit	
SRD	270
SRS	272
Tapping Chuck	
STM	274
FSC	278
Arbors	
MTA	280
SL2	281
FMH•A	282
FMA•A	284
FMB•A	286
FMC•A	288
SCA	290
Angle Head	
AH, AH-OH 90°	292
AH, AH-OH 45°	294
Coolant Accessories	
PSB, CP	296

HSK•A Series

Milling Chuck

CT•SA	298
-------------	-----

Collet Holder

HDC•A	302
SDM	304
GDC•A	306
ERC	308
ERC-T	310

"R" Zero Holder

HDZ	312
CTZ •SA	314
GDZ	315
ERZ	317
PHZ•S	318

Hydraulic Chuck

PHC•H	329
PHC•A	320
PHC•SA-C	323

PHC•SA-NC	324
PHC•SA	325

Shrink Fit

SRK	330
SRD	332
SRS	336

Tapping Chuck

SMH	338
STM	340
FSC	344
STP	345
TP1	347

Arbors

SLH	348
SLA	350
SL2	351
SLD	352
FMH•A	353
FMA•A	355
FMB•A	356
FMC•A	357
SCA	358
MTA	359
MS	360

Keyless Drill Chuck

KLD	362
-----------	-----

Angle Head

AHE	363
AHSE,AHLE	365

HSK•E Series

Collet Holder

HDC•A	366
ERC	368

Hydraulic Chuck

PHC•A	369
-------------	-----

Shrink Fit

SRD	370
SRS	371

HSK•F Series

Collet Holder

HDC•A	372
ERC	373

Hydraulic Chuck

PHC•A	374
-------------	-----

HSK · C Series

MN5523 · J 376

HSK Zanco / HSK Shank 378

HSK · T Series

SBV 381

SBN 382

SBH 383

SBT 384

TSB 385

TSD 387

C · Series

HDC · A 390

TSB 392

TSD 393

CT · SA 394

HDZ 395

PHC · A 396

STM 398

SRD 400

FMA 401

DCLN 402

DDUN 403

DSSN 404

DSDN 405

PCLN 406

PDUN 407

PSSN 408

PSKN 409

SVJB 410

SVVB 411

DCLN 412

SVQB 413

STFC 414

UTS Series

Milling Chuck

CT · SA 416

Collet Holder

HDC · A 418

SDM 420

ERC 422

ERC-T 423

"R" Zero Holder

HDZ 424

CTZ · SA 426

ERZ 427

Hydraulic Chuck

PHC · H 434

PHC · A 428

PHC · SA-C 429

PHC · SA 430

Shrink Fit

SRK 436

SRS 437

Tapping Chuck

STM 440

FSC 444

Arbors

FMH · A 445

FMA · A 447

SISTEMA DE MECANIZADO DE LA SERIE MÁQUINAS ESPECIALIZADAS SPECIALIZED MACHINE SERIES TOOLING SYSTEM

Stub Holder

KH-E 452

KHB-E 453

KH-EC1 454

KH-EC2 455

KH-A 458

KHB-A 459

KH-A-NL 460

KH 461

KHB 462

Tapping Chuck

KTP 473

KTL 474

KTLP 475

Tap Adapter

WE 480

WES · B 481

WEN 482

WESN · B 483

WEC 484

WENC 485

Adjustable Adapter

D 492

F 494

H, M	496
N	497
T	498

Endmill Chuck

EM • A	502
--------------	-----

Straight Drill Chuck

DC	506
DC • T, DC • N	507
ED • A	509
ED para Diámetros Pequeños / ED For Small Diameters	511

Floating Holder

FH-Tr	515
FH-MT	516
FH-ST	517
FH-ST-HDC • A	519

SERIES DE EQUIPO RELACIONADO RELATED EQUIPMENT SERIES

Llave de torque y cabeza de llave inglesa / Spanner Head Torque Wrench

BT/QL-MH	522
SH/CL	523

Shrink Fit System

ISG3400	524
SRK-HA1, SRK-HB2	528
SPN2-SRK-PS1	529

Preajustador de Herramientas / Tool Presetter

AOTP	530
SOTP	534

Abrazadera HSK / HSK Clamper

SPN1-HSK	538
HCL	539

"R" Zero Setter

SPZ-2	540
-------------	-----

Ajustador sencillo / Simple Setter

SPHV-3	541
SPN	544
SPK-K	548
SPK-KHA	551
SPW	554
SPK-STC	557
SPT	560

CASQUILLOS Y TALADRO BISELADO BUSH AND CHAMFERING DRILL

Guías de taladro "brocas" / Drill Jig Bush

A	566
---------	-----

B	568
C	570
D	572
E	574
F	576
G	578
T	579
R	580

Cortadores para biselado / Chamfering Cutter Series

FM	583
BM	584
BZ	585

Productos para Biselado / Chamfering Series

Taladro biselado / Chamfering Drill	587
Taladro biselado NUEVO / NEW Chamfering Drill	588
Portabisel / Chamfering Holder	589

SOLUCIÓN DE PROBLEMAS TROUBLESHOOTING

Portaherramienta de Fresado / Milling Chuck	592
Portaherramienta Hidráulico / Hydraulic Chuck	594
Portaherramienta de Zanco Recto / Stub Holder	596
Portaherramienta de Machuelado / Tapping Chuck	598

NOTAS

Guía de Selección de Portaherramienta

Holder Selection Guide

Tipo de Portaherramienta Holder Type	Modelo Model		Diámetro Diameter		Desempeño Performance			
			Métrico Metric	Pulgada Inch	Precisión de excentricidad Runout Accuracy	Rigidez Rigidity	Fuerza de Sujeción Clamping Force	Balance Balance
Milling Chuck	Super Tite-Lock Milling Chuck	CTSA	16-42 (6-32)	0.750-2.000 (0.250-1.500)	★★	★★★★	★★★★★	★★★
	Super Tite-Lock Milling Chuck (Flange Through Type)	CTSACF	16-42 (6-32)	0.750-2.000 (0.250-1.500)	★★	★★★★	★★★★★	★★★
Collet Holder	Drill Holder Easy Tool Length Adjustment	SDM	0.5-22	0.020-0.866	★★★	★★	★★	★★★
	High-Precision Collet Holder	HDCA	0.5-22	0.020-0.866	★★★	★★	★★	★★★
	High-Precision Collet Holder (Flange Through Type)	HDCACF	0.5-22	0.020-0.866	★★★	★★	★★	★★★
	High-Precision Collet Holder (High-Balanced Type)	GDCA	0.5-22	0.020-0.866	★★★	★★	★★	★★★★★
	Collet Holder For Small Diameters	ERC	—	0.020-0.394	★★★	★	★	★★★
"R"Zero Holder	"R" Zero Holder For Large Diameters	CTZSA	25-42 (6-32)	—	★★★★★	★★★	★★★★★	★★★
	"R" Zero Holder	HDZ	0.5-22	0.020-0.866	★★★★★	★★	★★	★★★
	"R" Zero Holder (High-Balanced Type)	GDZ	0.5-22	0.020-0.866	★★★★★	★★	★★	★★★★★
	"R" Zero Holder For Small Diameters	ERZ	0.5-7	0.200-0.276	★★★★★	★	★	★★★
	Slim Hydro "R" Zero Holder	PHZ-S	6-12	—	★★★★	★★	★★	★★★
Hydraulic Chuck	Power Hydro Chuck	PHC-A	4, 6-32 (3-16)	0.250-1.250	★★★★	★★★	★★★	★★★
	Slim Hydro Chuck	PHC-S	6-12 16, 20, 25	0.250-0.500	★★★★	★★	★★	★★★
	Hydro Chuck Omega	PHC-H	16-42		★★★★	★★★★	★★★★★	★★★
Shrink Fit	Shrink Fit (Small Diameter Type)	SRE	3-8	—	★★★★	★★	★★	★★★★
	Shrink Fit (Slim type)	SRS	6-32	0.250-0.750	★★★★	★★	★★	★★★★
	Shrink Fit (Heavy type)	SRK	6-32	—	★★★★	★★★★★	★★★	★★★★
	Shrink Fit (DIN Standard)	SRD	6-32	0.250-1.500	★★★★	★★★★★	★★★	★★★★
Side Lock Holder	Side Lock Holder	SLA	16-42		★	★★★★★	★★★★	★★
	Side Lock Holder	SL2	6-42		★	★★★★★	★★★★	★★
	Side Lock Holder	SLB	16-48		★	★★★★★	★★★★	★★

(Cuando se
utiliza con boquilla)
(When collet is used)

Tipo de Portaherramienta Holder Type	Modelo Model	Accesorio Accessory			Función Function	Barrenado Drilling		Fresado End-milling			Escariador Reamer
		Boquilla Collet	Tuerca Cap	Llave Allen o Inglesa Wrench Spanner		Normal	Alta Precisión High Precision	Pesado Heavy	Ligero Light	Alta Precisión High Precision	Rima Reaming
Milling Chuck	CTSA	MC ※1		HS	Refrigerante Coolant	●		●	●		
	CTSACF	MC ※1		HS	Pasador con Reborde Flange Through	●		●	●		
Collet Holder	SDM	FDC	HDP	S	Refrigerante Ajuste longitudinal Coolant Length Adjustment	●	●				●
	HDCA	FDC	HDP	S	Refrigerante Coolant	●	●		●	●	●
	HDCACF	FDC	HDP	S	Pasador con Reborde Flange Through	●	●		●	●	●
	GDCA	FDC	GDP	FK	Refrigerante, Alto-Balace Coolant ,High-Balanced	●	●		●	●	●
	ERC	ER FDC-07	ERP	S-E	Refrigerante Coolant	●					
"R"Zero Holder	CTZSA	MC ※1		HS	Refrigerante, Ajuste de excentricidad Coolant Runout Adjustment	●	●		●	●	●
	HDZ	FDC	HDP	S	Refrigerante Ajuste de Excentricidad Ajuste longitudinal Coolant Runout Adjustment Length Adjustment	●	●		●	●	●
	GDZ	FDC	GDP	FK	Refrigerante Ajuste de Excentricidad Alot-Balace Coolant Runout Adjustment High-Balanced	●	●		●	●	●
	ERZ	ER FDC-07	ERP	S-E	Refrigerante Ajuste de Excentricidad Coolant Runout Adjustment	●	●				●
	PHZ-S			L	Refrigerante Ajuste de excentricidad Coolant Runout Adjustment	●	●		●	●	●
Hydraulic Chuck	PHC-A	PHS ※1		L	Refrigerante Ajuste Longitudinal Coolant Length Adjustment	●	●		●	●	●
	PHC-S			L	Refrigerante Coolant	●	●		●	●	●
	PHC-H	PHS H		L	Refrigerante Coolant	●	●	●	●	●	●
Shrink Fit	SRE				Refrigerante Coolant	●	●		●	●	●
	SRS				Refrigerante Coolant	●	●		●	●	●
	SRK				Refrigerante Coolant	●	●	●	●	●	●
	SRD				Refrigerante Coolant	●	●	●	●	●	●
Side Lock Holder	SLA					●		●			
	SL2					●		●			
	SLB					●		●			

※ 1. Puede ser utilizado sin una boquilla.
※ 1. Can be used without a collet.

NOTAS

INTRODUCCIÓN DE PRODUCTO

PRODUCT INTRODUCTION

Portaherramientas "ECO"

Eco Holder Series



Reduce desperdicios
Waste saving

Ahorro de energía
Energy saving

Ahorro de recursos
Resource saving

Tecnología **NT** en portaherramientas Cuidamos el ambiente y ahorramos recursos

NT's Holder Technology

- For people, limited resources and the environment -

Portaherramienta BT de doble contacto, ligero y eficiente
Lightweight, efficient & two-face contact BT holder

AHO
Ahorra electricidad
Saves electricity

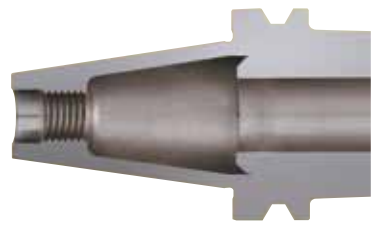

Boquilla para maquinado semi seco
Collets for semi-dry machining

FDC-MS
+
Portaherramienta para maquinado semi seco
Holder for semi-dry machining
Reduce el uso de refrigerante
Minimizes coolant usage



Portaherramienta a prueba de óxido
Rustproof tool holder

BT
*Existen excepciones
Some holders are exceptional

Reduce el uso del aceite para la prevención del óxido
Reduces use of rust prevention oil



"R" zero holder

HDZ
GDZ
ERZ

Incrementa la vida de la herramienta de corte
Prolongs tool life



NT TOOL ¡la mejor protección contra el óxido!

NT TOOL, the best protection against rust!

Revestimiento especial a prueba de óxido sobre toda la superficie, incluyendo el zanco. (Sólo CAT, BT y SK)

Special rust proof coating on entire surface including the tapered shank. (CAT, BT, SK only)

Previene el atascamiento y las ralladuras ocasionadas por la abrasión del metal contra el husillo de la máquina.

Prevent seizure and scoring caused by metal abrasion against the machine spindle.

El revestimiento especial protege al husillo del desgaste anormal.

Special coating protects spindle from abnormal wearing.

Es seguro de usar con refrigerante soluble en agua.

Safe with water-soluble coolant.

*Algunos portaherramientas están excluidos.

*Some holders are excluded.



Protege al husillo de daños

Protect spindle from damage

La vida de la herramienta de corte es más larga

Longer cutting tool life

Mantiene buena precisión

Maintain good accuracy

Inoxidable Rustproof

Los portaherramientas inoxidables de NT TOOL mantienen la precisión en los procesos sin medidas de prevención contra óxido adicionales.

NT TOOL's rust-proofed holders maintain processing accuracy without additional rust prevention.

Portaherramientas ordinarios Ordinary tooling

Sin el mantenimiento apropiado para la prevención de óxido, los portaherramientas ordinarios empiezan a oxidarse después de varios días de usarse. El óxido tiene efectos negativos en la precisión del mecanizado y/o en el husillo.

Cuando la zona del zanco se oxida, la precisión de la excentricidad de la punta de una herramienta de corte se deteriora entre 0.01-0.02 mm.

Without proper maintenance for rust prevention, ordinary tool holders will begin to rust after several days in use. This rust has negative effect on machining accuracy and/or spindle.

When the taper area gets rusty, the runout accuracy of the tip of a cutting tool deteriorates by 0.01-0.02mm.

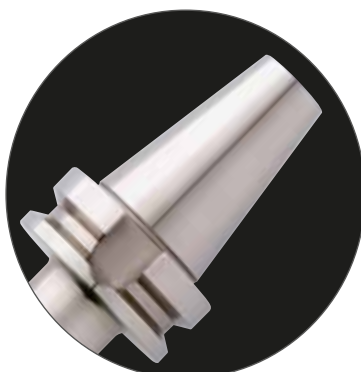

Tratamiento especial de superficie de NT TOOL
NT's special surface treatment

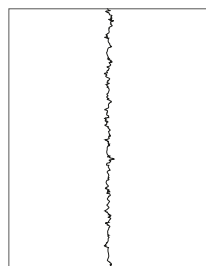

RMAX 0.8 μ



Superficie oxidada de un producto estándar
Rusted surface of standard product

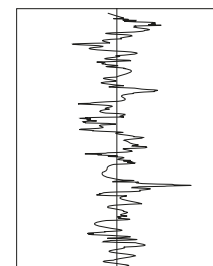

RMAX 15 μ

SYNCHROFIT II

El diseño elástico y único de NT Tool, reduce el estrés en el machuelo y mejora la vida de la herramienta de corte.

NT Tools's unique elastic design reduces tapping stress and improves cutting tool life.

Mejora la vida del machuelo de 2 a 5 veces
(comparado con los portaherramientas actuales)
Tap life is improved by 2 to 5 times. (Compared to current tool holders)

- La presión en el machuelo se reduce en 1/5 o menos.
- El desgaste y quiebre del machuelo se suprime.

- Thrust load on the tap is reduced by 1/5 or less.
- Tap wear and tear is suppressed.

Mejora la precisión del machuelado.
Tapping precision is improved.

- Calculando meticulosamente el machuelado de tensión/compresión provee variaciones mínimas en la profundidad.

- Fully calculated tapping tension/compression provides a minimized depth variation.

No requiere mantenimiento.
Maintenance-free.

- Portaherramienta construido en una sola pieza con diseño elástico y único

- One piece body constructed with a unique elastic design.

SYNCHROFIT II
SMH

Zanco recto pág. 131
BT pág. 132
HSK-A pág. 338



Precaución
Al seleccionar la herramienta de corte, verifique que incluya función de auto guía y liberación de estrés "con-eccentric".
Caution
With tap selection, use self-guiding con-eccentric relief tap.

Un producto original de NT construido en una sola pieza con un diseño elástico único.
NT's original one piece body constructed with a unique elastic design.

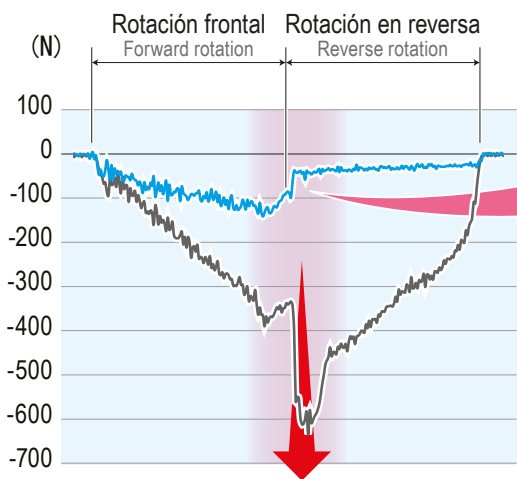

Una extensa carga de presión
(causada por error de sincronización)
Large thrust load (Caused by synchronization error)

La presión de carga se reduce cerca de 1/5 de las cargas convencionales
The thrust load is reduced by about 1/5 of conventional loads.

SYNCHROFIT II	herramienta - tool	M10x1.5
Portaherramienta rígido	Pieza de trabajo - work Piece	S45C
	Velocidad de rotación - Rotational speed	25m/min

El diseño elástico desarrollado dentro de una sólo pieza generará una contracción a lo largo del proceso durante la rotación del machueado, reduciendo considerablemente el estrés de la herramienta de corte.

The elastic design built into the one piece construction will twist along with the rotational direction during threading, greatly reducing the stress to the cutting tool.

Incrementa la vida del machuelo (con chaflán corto)

Tap life increases (With short chamfers)

Vida del machuelo evaluada (MAX: Probado 1000 veces)

Condiciones de maquinado

Herramienta : M4 x 0.7 (Suministro=1 inclinación)

Material de la pieza de trabajo : S45C

Velocidad de corte : Velocidad periférica 10m/min

Evaluated tap life (MAX: Tested 1000 times)

Processing Conditions

Tool : M4 x 0.7 (Feed=1 pitch)

Work Material : S45C

Cutting Speed : Peripheral speed 10m/min

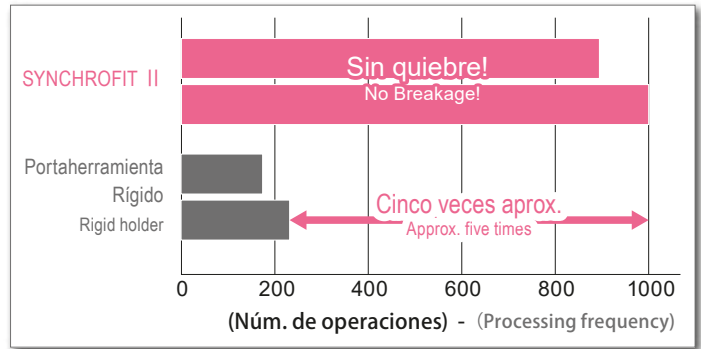

Incrementa la vida del machuelo (con machuelo de roscado por laminación)

Tap life increases (With rolling tap)

Vida del machuelo evaluada (MAX: Probado 1151 veces)

Condiciones de maquinado

Herramienta : M10 x 1.5 (Suministro=2 inclinación)

Material de la pieza de trabajo : SCM440(30HRC)

Velocidad de corte : Velocidad periférica 15m/min

Evaluated tap life (MAX: Tested 1151 times)

Processing Conditions

Tool : M10 x 1.5 (Feed=2 pitch)

Work Material : SCM440(30HRC)

Cutting Speed : Peripheral speed 15m/min

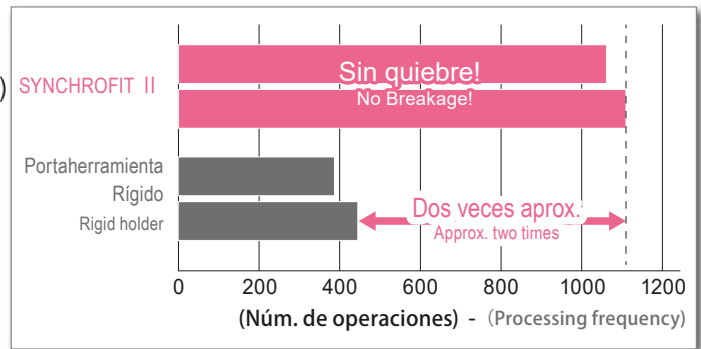

Calculando meticulosamente el machuelado de tensión/compresión provee variaciones mínimas en la profundidad.
Fully calculated tapping tension/compression provides a minimized depth variation.

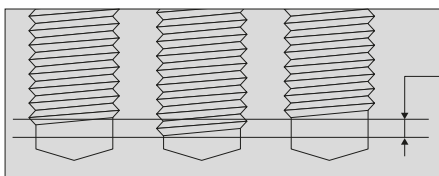

Variación de profundidad en el machuelo. - M10 profundidad de la cuerda del machuelo al girar. (27 agujeros por portaherramienta)

Tap depth variation. - M10 rolling tapping thread depth. (27 holes per holder)

Material de la pieza de trabajo S45C

Work S45C

Herramienta M10 x 1.5

Tool M10 x 1.5

Velocidad de corte Velocidad periférica 22m/min

Cutting speed peripheral speed 22m/min

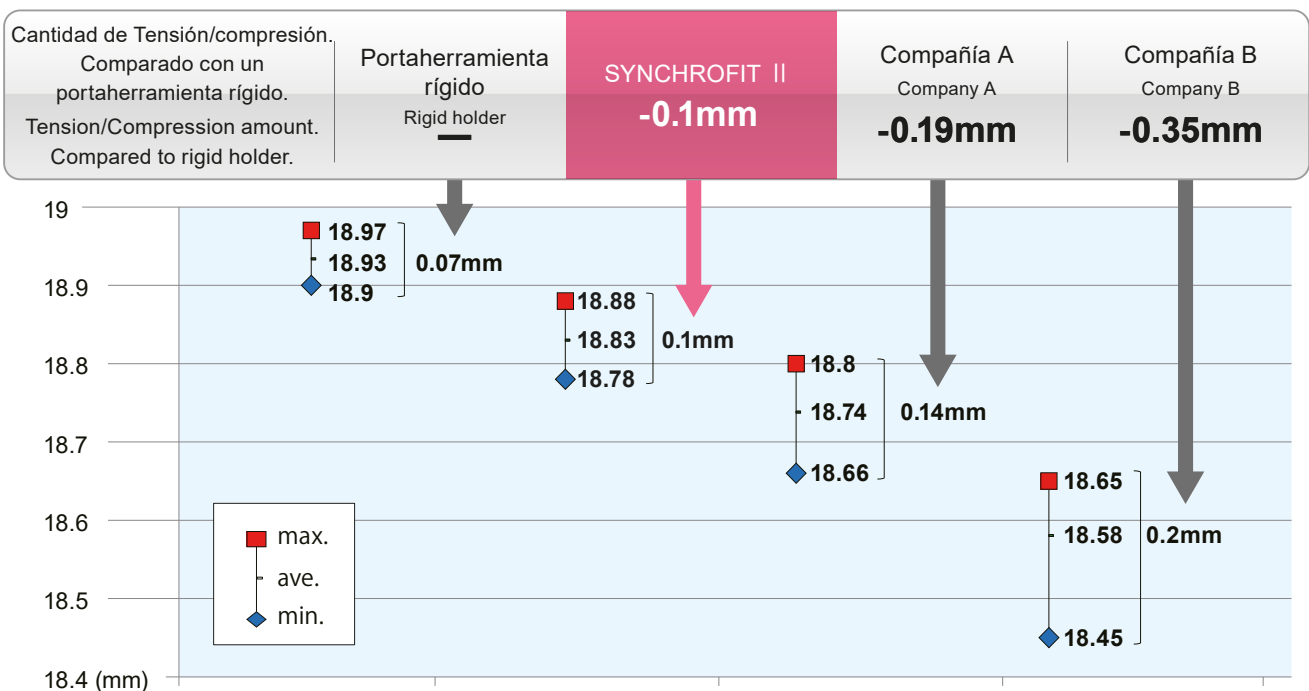

Herramientado para portaherramienta de Zanco poligonal C3~C6 Polygon Taper Shank Tooling C3 ~ C6

Ahora produciendo zancos poligonales de C3 - C6 de diámetro pequeño para máquinas de torno CNC.

Now producing C3 - C6 small diameter polygon shanks for CNC lathes.

C pág. 389

ISO 26623-1 Estándar
JIS B 6066-1 Standard

Turning Tool List
NC Tool List



Alta rigidez High rigidity

El portaherramienta de zanco poligonal de ISO estándar con doble contacto aumenta la rigidez.

The ISO standard dual-contact Polygon Taper increases rigidity.

Alta precisión en repetición creciente High repeat-mounting accuracy.

El acoplamiento del portaherramienta poligonal asegura una excelente precisión en rotación.

The polygon coupling ensures excellent accuracy in rotational direction.

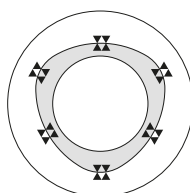

Ideas originales de NT + diseño de portaherramienta de zanco poligonal Polygon taper shank + NT original tooling

- "R" Zero
El Runout de los bordes de corte puede ser ajustado a cero
••• Línea de portaherramientas "R" Zero.
- Efecto anti-vibraciones
Sistema de sujeción hidráulico ••• Línea de portaherramientas hidráulicos.
- "R" zero
Runout of the cutting edges can be adjusted to zero.
••• "R" Zero Holder Series
- Anti-vibration effect
Hydraulic chucking system ••• Hydro chuck series.

Introduciendo a los portaherramientas Poligonales en bruto - Introducing Polygon taper blanks

Podemos fabricar piezas en bruto del portaherramienta de zanco poligonal de acuerdo a las especificaciones del cliente.

We can manufacture blanks with the polygon taper shank to the customer's specifications.

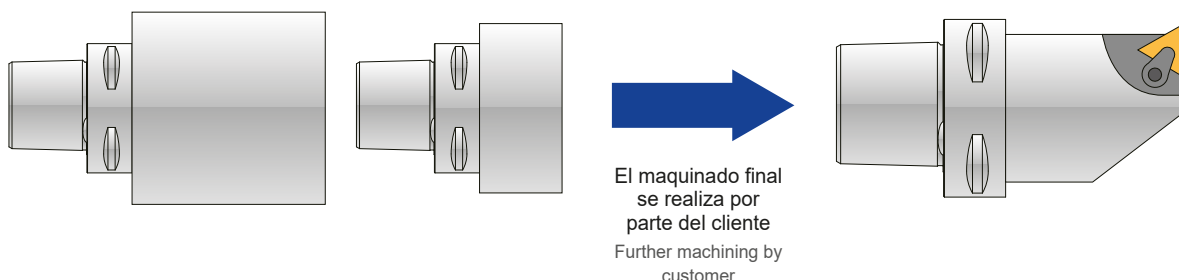

Portaherramienta Hidráulico Delgado Slim Hydro Chuck **PHC-SA**

¡Estos portaherramientas delgados son óptimos para eliminar la interferencia de las piezas de trabajo, con el portaherramienta en espacios reducidos.

These slim tools are optimized for eliminating workpiece interference in tight spaces!

¡Sencillo! ¡Rápido! ¡Fácil sujeción!

Easy! Quick! Simple Clamping!

Max. velocidad de rotación : MAX. 38,000min⁻¹

Max. rotational speed

Diámetro Interno \varnothing 3.0~ \varnothing 25.0

I.D.

Precisión: 3 μ m

Accuracy

Precisión en repetición: 1 μ m

Repeat Accuracy

Efecto anti-vibraciones permitiendo un mejor acabado

Anti-vibration effect provides better surface

Portaherramienta Hidráulico Delgado
Slim Hydro Chuck

PHC-SA

BT.....pág. 118

AHO.....pág. 264

HSK-A.....pág. 325

UTS.....pág. 430



Efecto anti-vibraciones

High anti-vibration effect

La cámara de aceite que rodea la manga del portaherramienta absorbe las vibraciones producidas por el proceso de corte.

Special oil chamber around the chucking sleeve absorbs cutting vibrations.

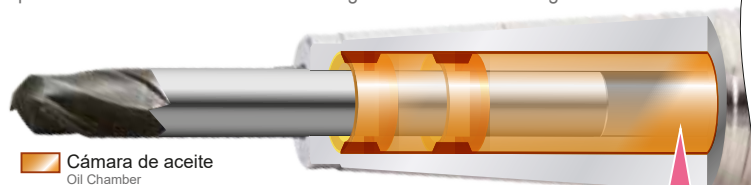

Cámara de aceite
Oil Chamber

La cámara de aceite que rodea la manga del portaherramienta absorbe las vibraciones producidas por el proceso de corte.

Oil chamber around the chucking sleeve absorbs cutting vibrations.

El efecto anti-vibraciones, provee un mejor acabado superficial

Anti-vibration effect provides better surface finishing

Velocidad de rotación	4,200 min ⁻¹	Alimentación	850 mm/min
Rotational Speed	4,200 min ⁻¹	Feed	850 mm/min

\varnothing 12 fresador de carburo con cuatro flautas irregulares
 \varnothing 12 carbide end-mill with 4 irregular pitch flutes



Portaherramienta Térmico de tipo delgado
Slim type Shrink Fit Chuck



Portaherramienta Hidráulico Delgado
Slim Hydro Chuck

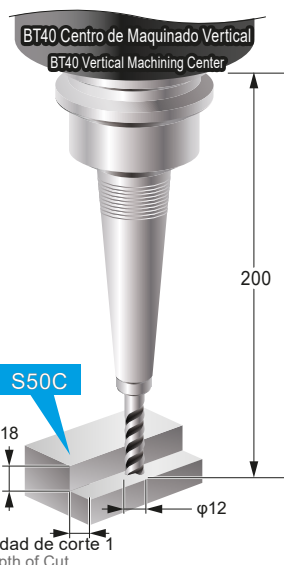

Profundidad de corte 1
Depth of Cut

Uso para

Use for

Acabado en fresa cilíndrica en máquina de 5 ejes

Finishing with ball endmill on 5-axis machine



Acabado en fresa para acabado circular en espacios angostos

Finishing with ball endmill in tight space



Barrenado en espacio angosto

Drilling in tight space



Portaherramienta Hidráulico Delgado Slim Hydro Chuck Blaster **PHC-SA-C**

Nueva serie "Blaster": En maquinados obtendrá mayor eficiencia y extenderá la vida de la herramienta de corte.

New "Blaster" series: Get high efficiency in machining and longer tool life!

Diámetro Interno I.D.
 PHC-SA-C : $\varnothing 3.0 \sim \varnothing 25.0$
 PHC-SA-NC : $\varnothing 4.0 \sim \varnothing 12.0$

Precisión Accuracy $3 \mu m$

El efecto anti-vibraciones, provee un mejor acabado superficial
 Anti-vibration effect provides better surface

"Blaster" Portaherramienta Hidráulico Delgado Slim Hydro Chuck Blaster
PHC-SA-C

BT.....pág. 115
 AHO.....pág. 262
 HSK-A.....pág. 323
 UTS.....pág. 429

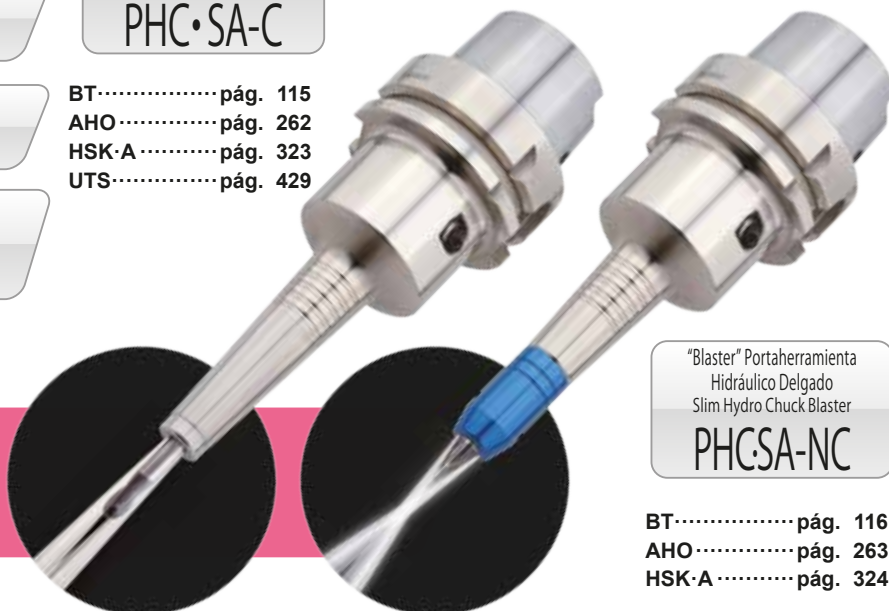

"Blaster" Portaherramienta Hidráulico Delgado Slim Hydro Chuck Blaster
PHC-SA-NC

BT.....pág. 116
 AHO.....pág. 263
 HSK-A.....pág. 324

Suministra efectivamente el refrigerante hacia el borde de corte.
 Effectively supplying coolant to cutting edge.



Efecto anti-vibraciones

High anti-vibration effect

La cámara de aceite que rodea la manga del portaherramienta absorbe las vibraciones producidas por el proceso de corte.
 Special oil chamber around the chucking sleeve absorbs cutting vibrations.



■ Cámara de aceite
 Oil Chamber

La cámara de aceite que rodea la manga del portaherramienta absorbe las vibraciones producidas por el proceso de corte.
 Oil chamber around the chucking sleeve absorbs cutting vibrations.

Accesorios Accessories

Cepillo de limpieza para zanco interno
 Inner Shank Cleaner Brush



• Para limpiar el zanco interno
 • To clean inner shank

Verificador de torque (se vende por separado)
 Torque check gauge (Sold separately)



• Si el medidor para verificación de torque no puede ser rotado con sus dedos, no se pierde la fuerza de sujeción.
 • If the Torque check gauge can't be rotated with your fingers, there is no loss of gripping force.

Tornillo de preajuste (se vende por separado)
 Preset Screw (Sold separately)



• Con función de abastecimiento de refrigerante a través del centro.
 • Center through type.

Funda para PHC-SA-NC (Incluida)
 Cap for PHC-SA-NC (Included)



• Con función de abastecimiento de refrigerante a través del centro.
 • Center through type.

Tipo "Blaster" PHC · SA-C

Blaster type / PHC-SA-C

Con función de refrigerante por los costados de la herramienta de corte
Able to feed coolant along to cutting tool.



- Proporciona un efecto de enfriamiento a la herramienta de corte.
 - Remueve los trozos de material de la herramienta de corte.
 - Envía el refrigerante de manera segura hasta el punto de trabajo.
 - Max. Velocidad de rotación: Max 38,000min⁻¹
※BT30-PHC03SA-85-C
- Provides a cooling effect to the cutting tool.
 - Washes off cutting chips from cutting tool.
 - Sure way to deliver coolant to processing point.
 - Ma^x rotational speed: MAX 38,000min⁻¹
* BT30-PHC03SA-85-C



Barrenado en espacio angosto
Drilling in tight space



Acabado en fresa para acabado circular en espacios angostos
Finishing with ball endmill in tight space

Tipo "Blaster" con funda PHC · SA-NC

Blaster type with Cap / PHC-SA-NC

Minimiza la fuerza centrífuga y suministra el refrigerante con precisión.
Minimize centrifugal force and feed coolant accurately.



- El refrigerante llega a los bordes de la herramienta de corte gracias a los puntos de precisión.
 - El ángulo de expulsión de refrigerante puede moverse al cambiar las fundas.
 - Max velocidad de rotación: Max. 27,000min⁻¹
※BT30-PHC10SA-95-NC
- Pinpoints coolant at the cutting tool edge.
 - Coolant ejection's angle can be changed by switching caps.
 - Max rotational speed : MAX 27,000min⁻¹
* BT30-PHC03SA-95-NC



Máquinado en fresa en espacios angostos
(para impulsor etc)
Taper Endmill Machining (for impeller etc)

Hydro Chuck OMEGA Portaherramienta Hidráulico Omega **PHC•H**

¡Elimina el desplazamiento, vibración y/o desviación de la herramienta de corte!
¡Da el salto al maquinado de alta eficiencia!

No more pullout, chatter or deflection! Step on up to high-efficiency machining!

¡Sencillo! ¡Rápido! ¡Fácil sujeción!

Easy! Quick! Simple Clamping!

Max. velocidad de rotación : MAX. 20,000min⁻¹

Max. rotational speed

Diámetro Interno φ 16.0~ φ 42.0

I.D.

Precisión: 3μm

Accuracy

Precisión en repetición: 1μm

Repeat Accuracy

Efecto anti-vibraciones permitiendo un mejor acabado

Anti-vibration effect provides better surface

Hydro Chuck Omega

PHC•H

BT..... pág. 122

CAT..... pág. 219

AHO..... pág. 268

HSK•A pág. 329

UTS..... pág. 434



Alta precisión - High precision



Longitud de proyección: 4d

Projection length : 4d

Precisión: 3μm o menos

Precisión en repetición:

1μm o menos

Accuracy : 3μm or less

Repeat accuracy: 1μm or less

"Sistema de sujeción de doble contacto" para una sujeción estable y de alta precisión.

"Dual clamping points system" for stable and high precision clamping.

Efecto anti-vibraciones y Alta fuerza de sujeción

Anti-vibration effect & High clamping force

El depósito especial de aceite alrededor de la manga del portaherramienta absorbe las vibraciones producidas por el corte. Proporciona una fuerza de sujeción mayor a la de un portaherramienta hidráulico convencional.

Special oil chamber around the chucking sleeve absorbs cutting vibrations. Utilizes stronger gripping force than a conventional hydro chuck.

Amortigua altas vibraciones

High vibration dampening

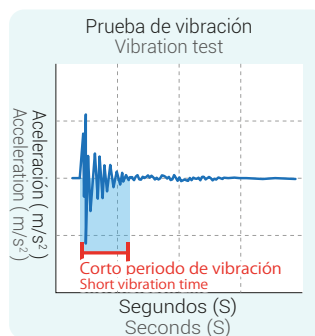

Comparación de fuerza de sujeción (φ20mm)

Gripping force comparison (φ20mm)

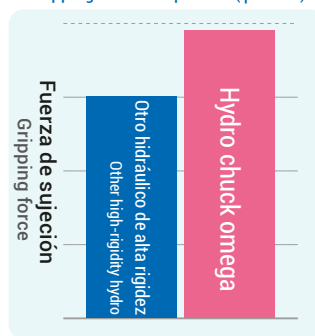

Alta rigidez - High rigidity

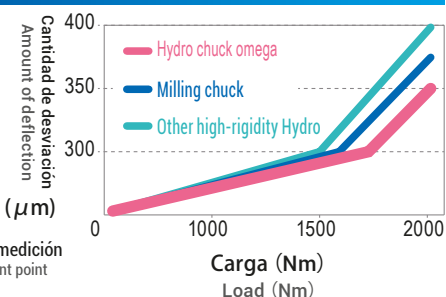
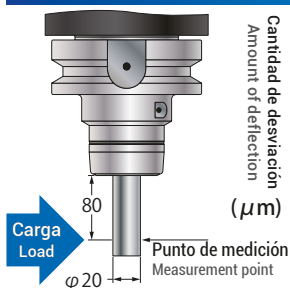

Alto balance - High balance

Diseño pre-balanceado más un balanceo individual por cada producto, permite el uso de altas velocidades de rotación.

Pre-balanced design and individual balancing for each product allows for high rotational speeds.

Máx. velocidad de rotación : Max. 20,000min⁻¹

Max. rotational speed : Max. 20,000min⁻¹

※BT40-PHC16H-45, HSK63-PHC16H-80.
Máxima velocidad de rotación para otros portaherramientas puede ser encontrado en la página de "dimensiones".

※BT40-PHC16H-45, HSK63-PHC16H-80.

Max rotational speed for other holders can be found on the dimensions page.

Maquinado de fresa con diámetro de $\phi 40\text{mm}$ y 6 flautas
 $\phi 40\text{mm}$ 6 flute end mill machining

¡Alta fuerza de sujeción previene el desprendimiento de la herramienta de corte!
High gripping force prevents tool pullout!

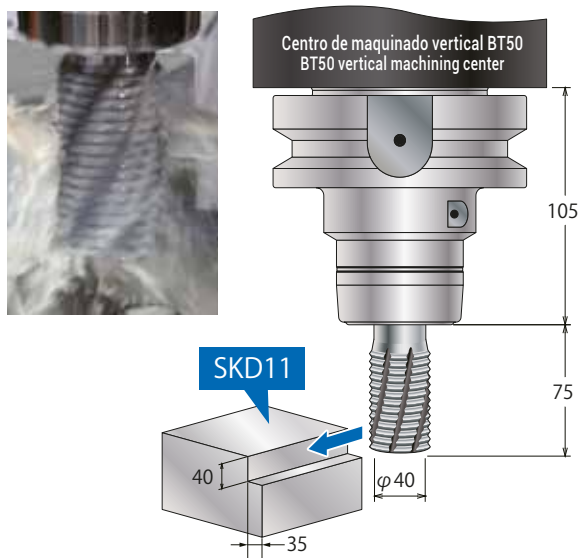

Velocidad de rotación	212 min^{-1}	Avance	0.5 mm/rev
Velocidad de corte	106 mm/min	Suministro de refrigerante externo	
Velocidad periférica	21.3 m/min	Feed rate	0.5 mm/rev
Rotational speed	212 min^{-1}	Coolant	External Oil Supply
Feed	106 mm/min		
Peripheral speed	21.3 m/min		

Otro hidráulico de alta rigidez
Other high-rigidity Hydro

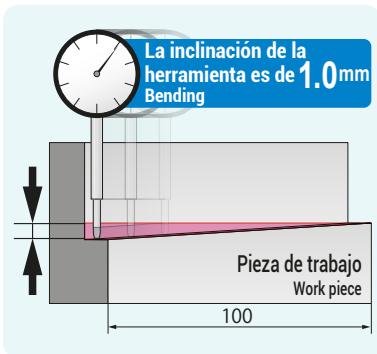

Hydro Chuck Omega

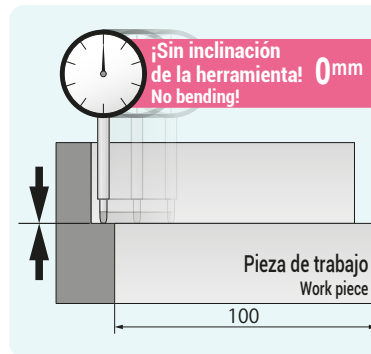

Maquinado de fresa cuadrada de 4 flautas con $\phi 20\text{mm}$
 $\phi 20\text{mm}$ carbide 4 flute square end mill machining

¡la alta rigidez y precisión reducen la inclinación al maquinar la superficie!
High rigidity and accuracy reduce inclination of machining surface!



Velocidad de rotación	6,350 min^{-1}	Avance	0.56 mm/rev
Velocidad de corte	3,570 mm/min	Suministro de refrigerante externo	
Velocidad periférica	398.7 m/min	Feed rate	0.56 mm/rev
Rotational speed	6,350 min^{-1}	Coolant	External Oil Supply
Feed	3,570 mm/min		
Peripheral speed	398.7 m/min		

※Velocidad de corte recomendada $F=2,100$ mm/min
※Recommended Feed $F=2,100$ mm/min

Otro hidráulico de alta rigidez
Other high-rigidity Hydro



Hydro Chuck Omega



Ra: rugosidad

Eliminando el exceso de material después del fresado, reduce la necesidad de corte a cero reduciendo los pasos posteriores al acabado.

Eliminating excess material after milling, reduces the need to zero cut and reduces machining in later steps (finishing).

¡Todo esto nos lleva a reducir los tiempos en el ciclo de producción!

This all leads to reduced cycle times!



Portaherramienta de Poder Hidráulico Power Hydro Chuck **PHC•A**

¡NUEVO! Portaherramienta hidráulico ¡Flexibilidad para usar boquillas!

Hydro chuck with collet holder flexibility!

¡Sencillo! ¡Rápido! ¡Fácil sujeción!

Easy! Quick! Simple Clamping!

Max. velocidad de rotación : MAX. 40,000min⁻¹

Max. rotational speed

Diámetro Interno φ 3.0~ φ 32.0

I.D.

Precisión: 3μm

Accuracy

Precisión en repetición: 1μm

Repeat Accuracy

Efecto anti-vibraciones permitiendo un mejor acabado

Anti-vibration effect provides better surface

Power Hydro Chuck

PHC•A

BT.....pág. 108

CAT.....pág. 211

AHO.....pág. 260

HSK•A.....pág. 320

UTS.....pág. 428

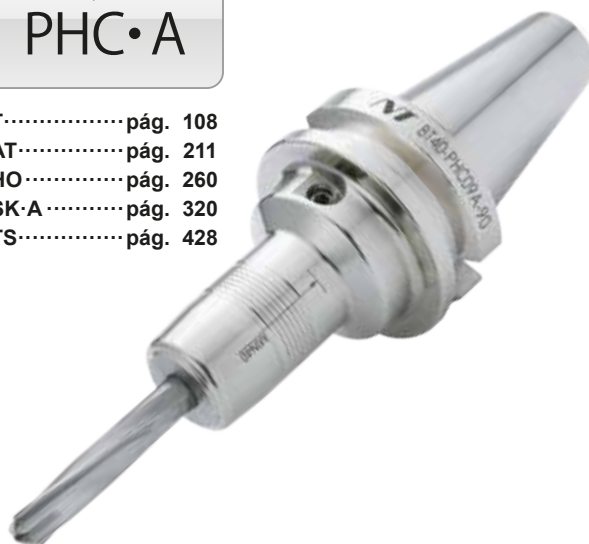

Alto balance - High balance

Diseño pre-balanceado, más un balanceo individual por cada producto, que permite el uso de altas velocidades de rotación.

Pre-balanced design and individual balancing for each product allows high rotational speeds.

Velocidad rotacional Max. 40,000min⁻¹
Max. rotational

※Para BT30-PHC03A-60. La máxima velocidad rotacional para otros portaherramientas puede ser encontrada en la página de dimensiones.

※For BT30-PHC03A-60. Max rotational speed for other holders can be found on the dimensions page.

¡Sencillo! ¡Rápido! ¡Fácil sujeción!

Easy! Quick! Simple Clamping!!

El sistema sencillo de sujeción con una sola llave elimina el error humano, por lo que se asegura la misma fuerza de sujeción sea aplicada sin importar quien gire el tornillo del portaherramienta.

The simple system of tightening with a single wrench eliminates human error. The same gripping force is ensured regardless of who tightens the chuck.



Alta precisión - High precision

En longitudes de herramienta equivalente a: 4d o menos

Projection length : 4d

La precisión del holder es de: 3μm o menos
En producción en serie: 1μm o menos

Accuracy : 3μm or less
Repeat Accuracy: 1μm or less

Ajuste de herramienta sin calibración de altura.

Tool pre-set without height offset.

Sistema de sujeción dual para una mayor estabilidad y alta precisión.

"Dual clamping points system" for stable and high precision clamping.

Diseño hidráulico balanceado. Previene la deformación durante el trabajo de sujeción.

Hydraulic balance design. Prevents deformation during chucking.

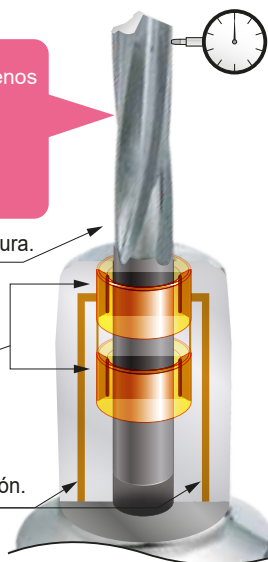

Efecto anti-vibraciones - Anti-vibration effect

La cámara de aceite que rodea la manga del portaherramienta absorbe las vibraciones ocasionadas por el maquinado.

Special oil chamber around the chucking sleeve absorbs cutting vibrations.

Prueba de Vibración
Vibration Test

Portaherramienta hidráulico
Hydro Chuck

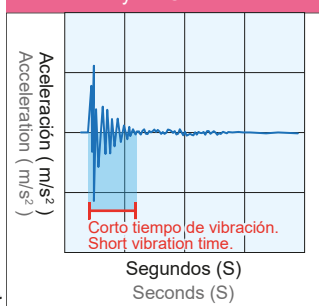

Portaherramienta térmico
Shrink Fit Chuck

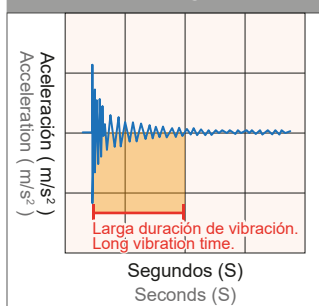

Función de ajuste de longitud (se vende por separado)

Length adjustment function (Sold separately)



- La altura de la herramienta de corte puede ser ajustada por un costado, utilizando una llave Allen.
- * Interfaz BT , CAT y SK. (* Excepto PHC03A, PHC04A)
- * Interfaz CAT/SK están disponibles. Favor de contactar a NT TOOL para mayor información.

- Cutting tool height can be adjusted on the side with a Hex. Wrench.

- * BT , CAT and SK shank. (* Except PHC03A, PHC04A)
- * CAT/SK shank are available. Please contact NT TOOL for details.

Boquillas con perno de retención (PHS series)

Collet with stopper pin. (PHS series)



Alimentación de refrigeración interna habilitada.
Internal coolant feeding enabled.

Herramienta con función de vena de lubricación
Tool with oil hole

Boquilla con función de refrigeración por los costados
For collet through coolant

Boquilla con perno de seguridad
Collet with stopper pin

El efecto anti-vibraciones, provee un mejor acabado en la superficie

Anti-vibration effect provides better surface finishing

Velocidad de rotación Rotational Speed	1650 min ⁻¹ 1650 min ⁻¹	4-flautas de carburo para fresado/desvaste 4-flute carbide Endmill
Velocidad de corte Feed	550 mm/min 550 mm/min	Alimentación por flauta Feed per flute 0.08 mm/flauta 0.08 mm/flute

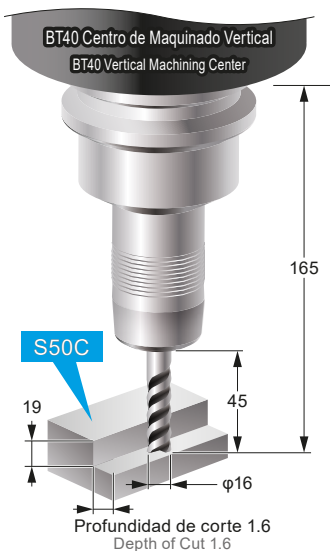

Uso para

Use for

Barrenado escalonado
Step drilling

Barrenado
Drilling

Rimado
Reaming

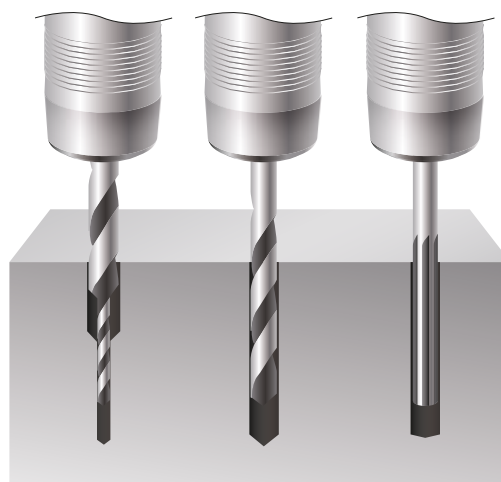

Ra: rugosidad



Accesorios - Accessories

Cepillo de limpieza para zanco interno
Inner Shank Cleaner Brush



- Para limpiar el zanco interno del Portaherramientas Hidráulico, etc.
- To clean inner shank of Hydro Chuck, etc.

Verificador de torque
(se vende por separado)
Torque check gauge (Sold separately)

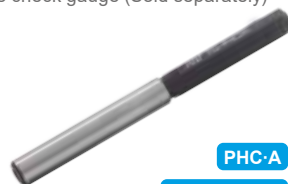

- Si el medidor para verificación de torque no puede ser rotado con sus dedos, no se pierde la fuerza de sujeción.
- If the Torque check gauge can't be rotated with your fingers, there is no loss of gripping force.

Boquillas con perno de seguridad
(se vende por separado)
Collet with stopper pin (Sold separately)



- Para PHC12A, PHC20A, PHC0500A & PHC0750A.
- Función para herramienta con vena de lubricación y refrigeración por los costados de la boquilla están disponibles.
- For PHC12A, PHC20A, PHC0500A & PHC0750A.
- Center through type and collet through type are available.

Portaherramienta Hidráulico Delgado Slim Hydro Chuck **PHC·S**

La opción perfecta para aplicaciones en espacios reducidos como acabado en fresa, barrenado y rimado en máquinas de 5 ejes.

Perfect choice for tight space applications, such as endmill finishing, drilling and reaming on 5-axis machines.

- ¡Sencillo! ¡Rápido! ¡Fácil sujeción!
Easy! Quick! Simple Clamping!
- Diámetro Interno \varnothing 6.0 ~ \varnothing 12.0, 16.0, 20.0, 25.0
I.D.
- Precisión: $3\mu\text{m}$
Accuracy
- Agarre antideslizante
No-slip grip
- Efecto anti-vibraciones permitiendo un mejor acabado
Anti-vibration effect provides better surface

PHC·S

CAT.....pág. 217



Preajuste de la herramienta sin ajuste de altura Tool pre-set without height offset

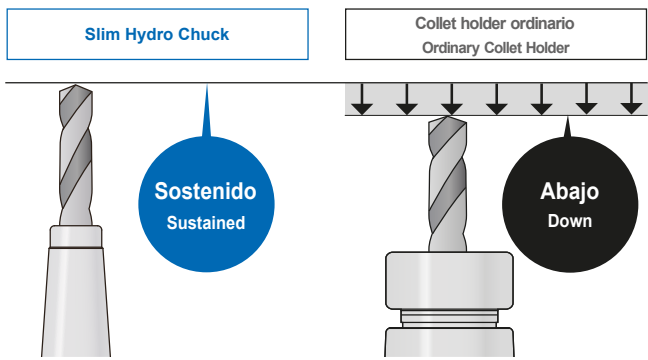

"Sistema de sujeción a dos puntos" para mayor estabilidad y mayor precisión. "Dual clamping points system" for stable and high precision clamping.

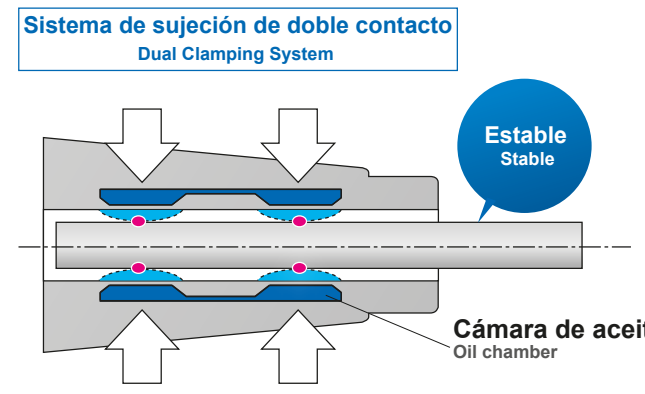

Alta precisión - High precision

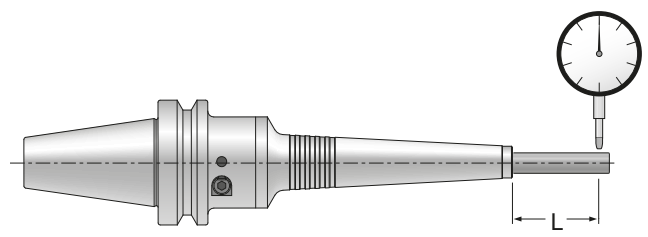

I.D. de portaherramienta Holder I.D.	Longitud de proyección (L) Projection length (L)	Precisión Accuracy
\varnothing 6~12, 16, 20, 25 (\varnothing 0.250"~0.500")	4d	$3\mu\text{m}$

Slim Type Shrink Fit Chuck

Prueba de vibración Vibration Test

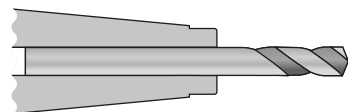
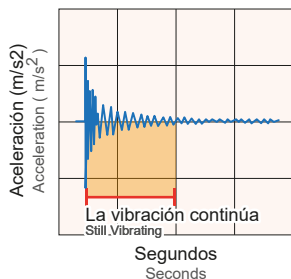

El cuerpo de metal sólido no absorbe las vibraciones producidas por el corte.
Solid metal body does not absorb cutting vibration.

Slim Hydro Chuck

Prueba de vibración Vibration Test

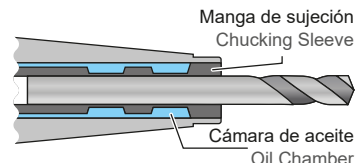
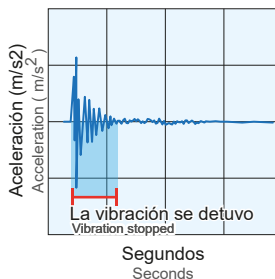

La cámara para aceite alrededor de la manga de sujeción absorbe la vibración del cortado.
Oil chamber around the chucking sleeve absorbs cutting vibrations.

Comparación de superficies de trabajo - Work surface comparison

Slim Type Shrink Fit Chuck



Slim Hydro Chuck

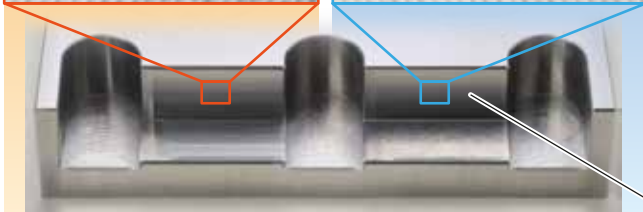

Condición de corte Cutting Condition

Máquina Machine	Centro vertical de maquinado Vertical Machining Center
Material de la pieza de trabajo Work Piece Material	S50C
Cortador Cutter	Fresa de carburo $\phi 12$ con 4 flautas irregulares con inclinación $\phi 12$ $\phi 12$ carbide end-mill with 4 irregular pitch flutes
Velocidad de rotación Rotational Speed	4,200min ⁻¹
Suministro Feed	850mm/min

Fresado de pared lateral: 1 mm x profundidad 18 mm

Side wall milling : 1mm × depth 18mm

Aplicaciones de corte - Cutting applications



Acabado en fresa para acabado circular en espacios angostos
Finishing with ball endmill in tight space



Acabado en fresa cilíndrica en máquina de 5 ejes
Finishing with ball endmill on 5-axis machine



Rima en espacio angosto
Reaming in tight space



Barrenado en espacio angosto
Drilling in tight space

Milling Chuck "R" Zero Holder ^{Super Tite-Lock} CTZ-SA



La excentricidad de los bordes de corte se puede ajustar a cero

Runout of the cutting edges can be adjusted to zero.

¡El sistema de ajuste de 4 puntos original de NT para un fácil, preciso y rápido ajuste de la excentricidad!
NT's original 4 Points adjustment system for easy, accurate and speedy runout adjustment!

- Orificio con diámetro invariables / Invariant hole diameter
- Mejor aspereza en la superficie / Better surface roughness
- Mayor vida de la herramienta / Longer tool life

Para diámetros largos
For Large Diameter
CTZ-SA



- BT.....pág. 102
- CAT.....pág. 209
- AHO.....pág. 258
- HSK-Apág. 314
- UTS.....pág. 426

Operación sencilla – la excentricidad del borde de corte se puede ajustar de 0 a 2 µm simplemente ajustando 4 tornillos de ajuste.

Simple operation - Runout of the cutting edge can be adjusted to 0 to 2 µm by simply tightening 4 adjustment screws.

Tipo portaherramienta Holder Type	Cantidad máxima ajustable (a 100 mm desde una punta del portaherramienta) Max. Adjustable Amount (at 100mm from a holder nose)
CTZ25SA	60 µm
CTZ32SA	50 µm
CTZ42SA	50 µm

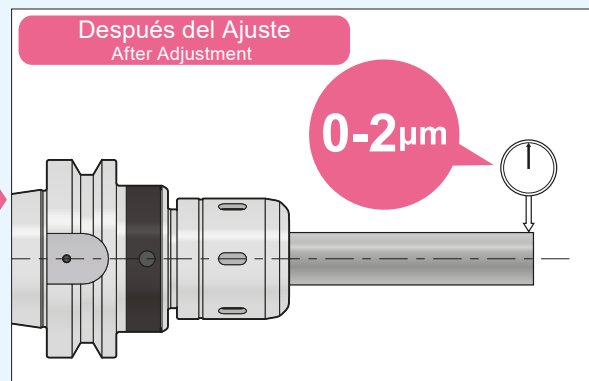
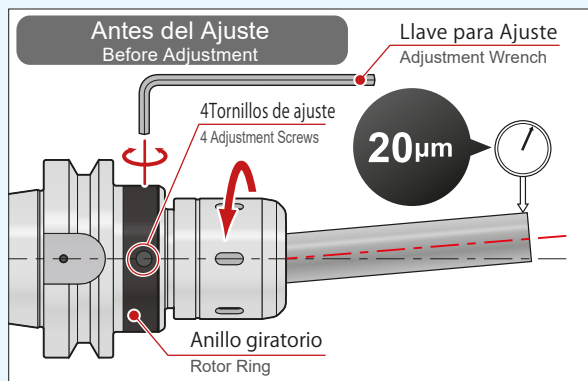

Datos de corte - Cutting Data

Datos de corte - rima

El ajustar el borde de corte a cero excentricidad hace posible hacer los acabados de orificios sin variaciones y precisos.

Cutting Data – Reaming

Adjusting the cutting edge to zero runout makes high precision and invariant holes finishing possible.

Condición de corte

Portaherramienta : BT40-CTZ32SA-125
Herramienta de corte : Escariador de carburo
Velocidad de rotación : 150min⁻¹(Velocidad periférica 13m/min)
Suministro : 45mm/min(0.3mm/rev)
Cantidad a quitar : φ0.3
Longitud de proyección : 280mm (longitud de proyección de la herramienta de corte:155mm)

Cutting Condition

Holder : BT40-CTZ32SA-125
Cutting tool : Carbide reamer
Rotation speed : 50min⁻¹(Peripheral speed 13m/min)
Feed : 45mm/min(0.3mm/rev)
Removing amount : φ0.3
Projection length : 280mm (Cutting tool projection length:155mm)

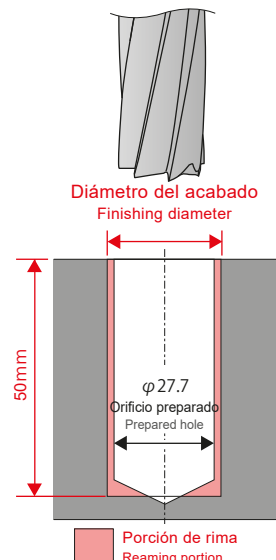
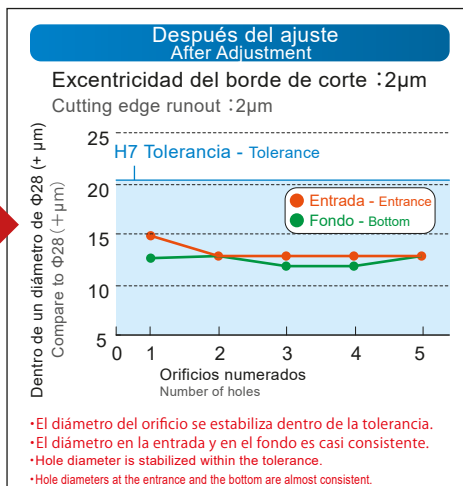
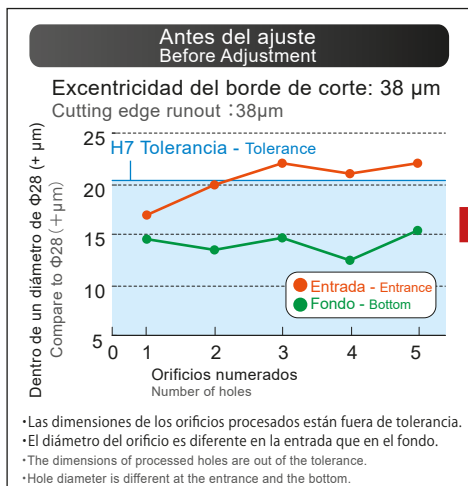

"R" zero holder series

Tipo estándar
Standard type

HDZ

BT.....pág. 100
CAT.....pág. 207
AHO.....pág. 256
HSK-Apág. 312
UTS.....pág. 424



Con alto balance
High balanced type

GDZ

BT.....pág. 104
HSK-Apág. 315



Para diámetros
pequeños
Small Diameter Type

ERZ

BT.....pág. 106
HSK-Apág. 317
UTS.....pág. 427



Zanco recto
Straight shank

ST-HDZ

BT.....pág. 086



Tipo hidráulico
delgado
Slim Hydro Type

PHZ·S

BT.....pág. 107
CAT.....pág. 210
HSK-Apág. 318



"R"Zero setter
SPZ-2

Rango de medición:
0-460mm en longitud
0~460
Measurement range:
0-460mm in length

Soporte giratorio
para portaherramienta
Rotary holder support

Dispositivo de jale del portaherramienta
Holder pull-in device



Orificios con diámetros invariables

Invariant hole diameter

Antes del ajuste
Before adjustment

La excentricidad del borde de corte: 15µm
Runout of the cutting edge: 15µm

Diferencia en el diámetro del orificio antes del ajuste
Variance of hole diameter before adjustment

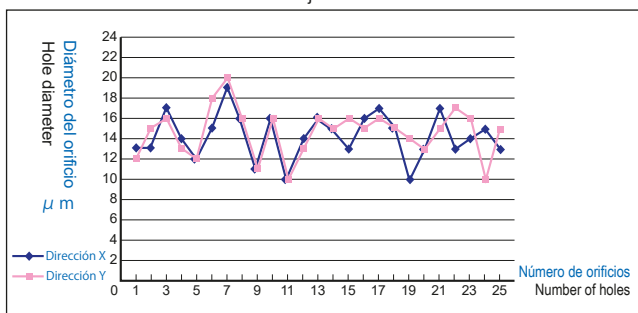

Después del ajuste
After adjustment

La excentricidad del borde de corte: 2µm
Runout of the cutting edge: 2µm

Diferencia en el diámetro del orificio después del ajuste
Variance of hole diameter after adjustment

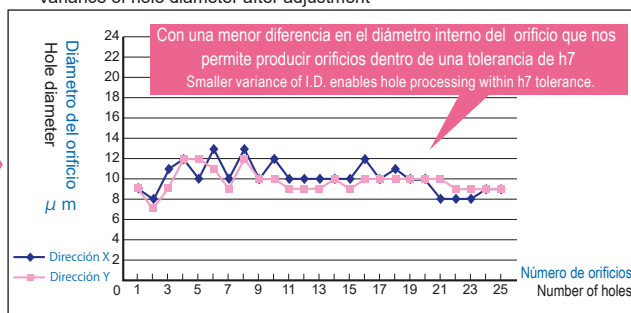

Con una menor diferencia en el diámetro interno del orificio que nos permite producir orificios dentro de una tolerancia de h7. Smaller variance of I.D. enables hole processing within h7 tolerance.

Mejor aspereza en la superficie

Better surface roughness

Aspereza de la superficie antes del ajuste
Surface roughness before adjustment

Rz 2.1µm~4.7µm

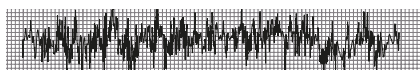

Aspereza de la superficie después del ajuste
Surface roughness after adjustment

Rz 1.0µm~2.5µm



La aspereza de la superficie mejora de manera notable
Surface roughness is remarkably improved.

Mayor vida de la herramienta

Longer tool life

Distancia de corte (m)
Cutting distance

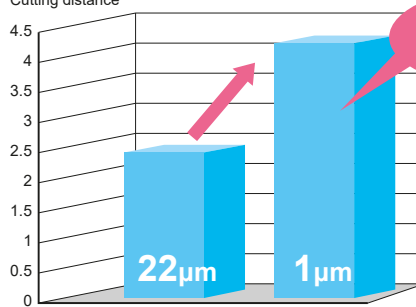

Mejorando la excentricidad
1.75 veces

La excentricidad del borde de corte Runout of the cutting edge

Portaherramienta hidráulico "R" Zero Holder Slim Hydro "R" Zero Holder **PHZ·S** **ECOHOLDER®**

Excentricidad cero inclusive con herramientas de corte de 200 mm. de longitud.

Zero runout even with 200mm cutting tool.

¡Sencillo! ¡Rápido! ¡Fácil sujeción!

Easy! Quick! Simple Clamping!

Max. velocidad de rotación : MAX. 17,000min⁻¹

Max. rotational speed

Diámetro Interno φ 6.0~ φ 12.0

I.D.

Precisión: 0-2μm

Accuracy

Precisión en repetición: 1μm

Repeat Accuracy

Efecto anti-vibraciones permitiendo un mejor acabado

Anti-vibration effect provides better surface

Slim Hydro "R" Zero Holder

PHZ·S

BT.....pág. 107

CAT.....pág. 210

HSK·Apág. 318



"R" Zero Setter

Operación sencilla – la excentricidad del borde de corte se puede ajustar de 0 a 2 μm simplemente ajustando 4 tornillos de ajuste.
Simple Operation - Runout of the cutting edge can be adjusted to 0 to 2 μm by simply tightening 4 adjustment screws.

Inclusive si la excentricidad en 4d se encuentra en un rango aceptable, la excentricidad actual de los bordes de corte es mucho mayor conforme la longitud del cortador sea más larga. El portaherramienta "R" Zero de "NT" no permite variaciones en el diámetro, da una mejor rugosidad a la superficie y mayor vida a la herramienta mediante el ajuste de la excentricidad y los bordes de corte lo más cercano a cero posible.

Even if the runout at 4d is in allowable range, runout at the actual cutting edge is much larger as the projection length of the cutter gets longer.

NT's "R" Zero holder realizes invariant hole diameter, better surface roughness and long tool life by adjusting runout at the cutting edge as closely as to zero.

Después del ajuste
After Adjustment

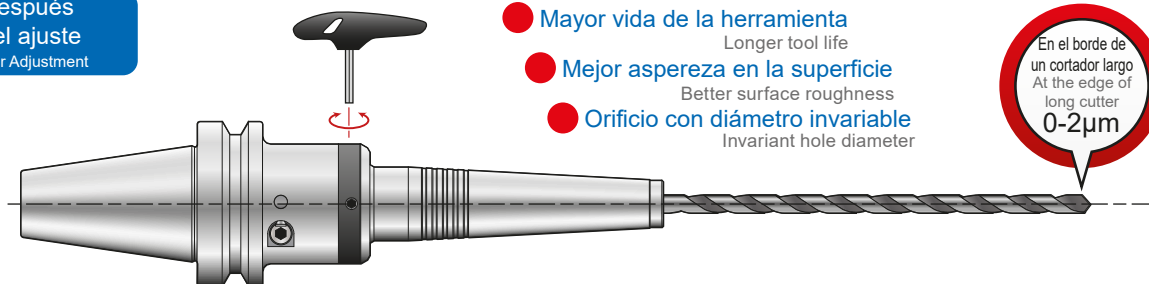

● Mayor vida de la herramienta
Longer tool life

● Mejor aspereza en la superficie
Better surface roughness

● Orificio con diámetro invariable
Invariant hole diameter

En el borde de un cortador largo
At the edge of long cutter
0-2μm

Uso para

Use for

Utilice herramientas de corte largas para visualizar las capacidades del portaherramienta

Use long cutting tools to display the holder's true capabilities!

Corte de alta precisión sin interferencia con la plantilla.
High precision cutting without interference with a jig.

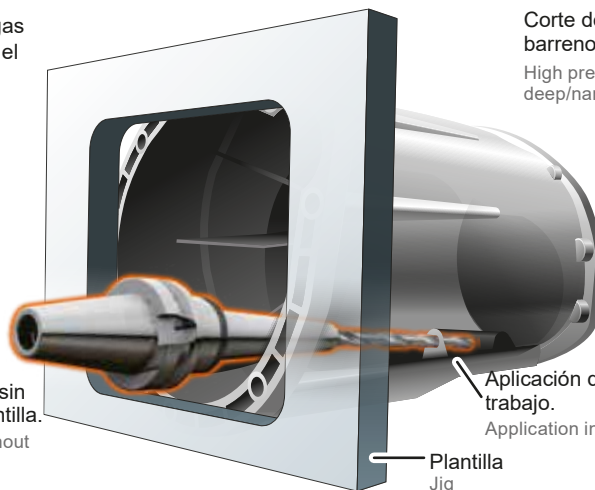

Corte de alta precisión en un barreno profundo/reducido.
High precision cutting in a deep/narrow hole.



Aplicación dentro de la pieza de trabajo.
Application inside of work piece.

Plantilla
Jig

Milling Chuck "R" Zero Holder ^{Super Tite-Lock} CT•SA

Precisión, rigidez y balance - Todo en uno

Accuracy, Rigidity and Balance - All in One.

Alto balance diseñado para aplicaciones alta velocidad
High-balance design for high speed applications.

Alta precisión y rigidez con una sola acción de sujeción.
High precision and rigidity with one simple tightening action.

El nuevo diseño "corte-T" minimiza el deslizamiento y el desprendimiento de la fresa.
Patented "T-slit" design minimizes slippage and pull out of end mill.

Tipo de alta rigidez
High Rigidity Type

CT•SA

Pasador con reborde
Flange Through Type

CT•SA-CF

BT.....pág. 064

BT.....pág. 066

CAT.....pág. 198

AHO.....pág. 250

HSK•A.....pág. 298

UTS.....pág. 416



⚠ Precaución

Favor de girar el anillo de sujeción en sentido contrario a las manecillas del reloj por más de una vez después de quitar una herramienta de corte.

⚠ Caution

Please rotate the clamping ring counterclockwise more than one time after a cutting tool is removed.



Alto balance High balance

- Su diseño cuidadosamente fabricado garantiza un balance de rotación excelente.
- La velocidad máxima de rotación es tan alta como la de los portaherramientas CT•S-E (alto balance).
- Carefully crafted design ensures excellent rotational balance.
- Maximum rotational speeds as high as CT•S-E (High balance) holders.

Velocidad máxima de rotación : Max. 20,000min⁻¹
Max. rotational speed

※ Para BT40-CT16SA-75. La velocidad máxima de rotación para otros portaherramientas puede encontrarse en la página de dimensiones.
※ For BT40-CT16SA-75. Max rotational speed for other holders can be found on the dimensions page.

El nuevo diseño "corte-T" minimiza el deslizamiento y el desprendimiento de la fresa.
New patented "T-slit" design minimizes slippage and pull out of end mill.

- 1** Ranura axial
Axial Slit
- 2** Corte radial (previene el desprendimiento de la herramienta)
Radial Slit (Prevents Tool Pull Out)
- 3** Ranura axial (previene la rotación de la herramienta)
Axial Slit (Prevents Tool Rotation)



Alta precisión y rigidez con una sencilla acción para apretar. High precision and rigidity with one simple tightening action.

El aro de sujeción puede apretarse hasta la base del portaherramienta.
The clamping ring can be tightened all the way to the holder base.

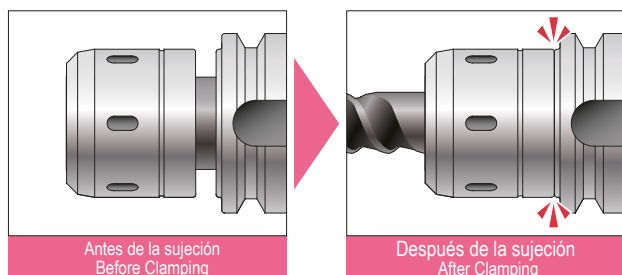

Con abastecimiento de refrigerante a través del centro Center through coolant feeding compliant



Para cortadores con vena de lubricación
For cutters with coolant hole



Con función de refrigerante por los costados con boquilla MC-C
For collet through coolant With MC-C collet

SERIE FÁCIL DE PREAJUSTE - EASY PRESET SERIES

Drill Holder With Easy Tool Length Adjustment

Para barrenado
For drilling

SDM

BT.....pág. 078
CAT.....pág. 202
AHO.....pág. 254
HSK-A.....pág. 304
UTS.....pág. 420

Con ajuste de altura de la
herramienta de corte
Adjustable tool length

Ajuste de longitud sencillo – todo lo que
tiene que hacer es girar el anillo guía
(No se necesita una herramienta adicional)

Simple length adjustment - all
you have to do is turn the guide
ring. (No additional tool is required.)



Ventajas del SDM - Advantages of SDM

1. La longitud de la herramienta puede ajustarse fácilmente al girar el anillo guía.
2. Con función de abastecimiento de refrigerante a través del centro. (Máx. 7 MPa)
3. El tornillo de preajuste asegura la rotación de la herramienta de corte con el transmisor de la espiga.
4. La medida de las herramientas de corte puede cambiarse simplemente reemplazando las boquillas.

1. Tool length can be adjusted easily by rotating the guide ring.
2. Center-through coolant feeding enabled. (Max. 7 MPa).
3. Preset screw securely locks rotation of cutting tool with tang drive.
4. Size of cutting tools can be changed by simply replacing collets.

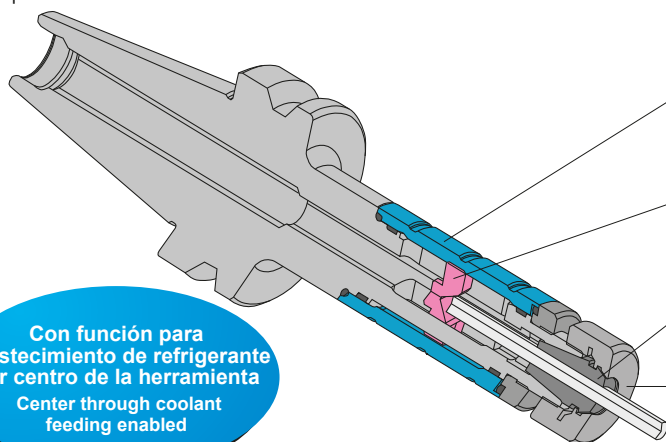

Con función para
abastecimiento de refrigerante
por centro de la herramienta
Center through coolant
feeding enabled

Anillo guía - Guide ring

La longitud de la herramienta se puede ajustar al girar el anillo guía.
Tool length can be adjusted by rotating this guide ring.

Tornillo de preajuste - Preset screw

Boquilla FDC (opcional) - FDC collet (optional)

Puede utilizarse con el HDC·A portaherramienta de boquilla
Can be shared with HDC·A collet holder.

Tuerca ciega HDP - HDP nut

Puede compartirse con el HDC·A portaherramienta de boquilla
Can be shared with HDC·A collet holder.

Función para ajuste de longitud - Length adjustment function



La longitud de la herramienta de corte se puede ajustar al girar el anillo guía manualmente.
Fácil de configurar a la longitud deseada – se puede ajustar al mismo tiempo que se mide la longitud.
Cutting tool length can be adjusted by rotating the guide ring manually.
Easy to set the targeted length - can be adjusted at the same time measuring the length.

SERIE DE PREAJUSTE SENCILLO - EASY PRESET SERIES

Synchronous Tap Holder With Easy Tool Length Adjustment

Para machuelear
For tapping

STM

BT.....pág. 134
CAT.....pág. 224
AHO.....pág. 274
HSK-A.....pág. 340
UTS.....pág. 418

Ajuste de altura de la
herramienta de corte
Adjustable tool length

Ajuste de longitud sencillo – todo lo que tiene que hacer es girar el anillo guía (No se necesita una herramienta adicional)

Simple length adjustment – all you have to do is turn the guide ring. (No additional tool is required.)



Ventajas del STM - Advantages of STM

1. La longitud de proyección del machuelo se puede ajustar con facilidad al girar el anillo guía.
2. Con función de refrigerante a través del centro de la herramienta. (Máx. 7 MPa)
3. Se puede prevenir el deslizamiento del machuelo con el conductor de preajuste.
4. Las medidas del machuelo se pueden cambiar al reemplazar los tornillos de preajuste y boquillas.

1. Tap projection length can be adjusted easily by turning the guide ring.
2. Center-through coolant feeding is possible (Max. 7 MPa).
3. Slippage of tap can be prevented by preset driver.
4. Tap size can be changed by replacing preset drivers and collets.

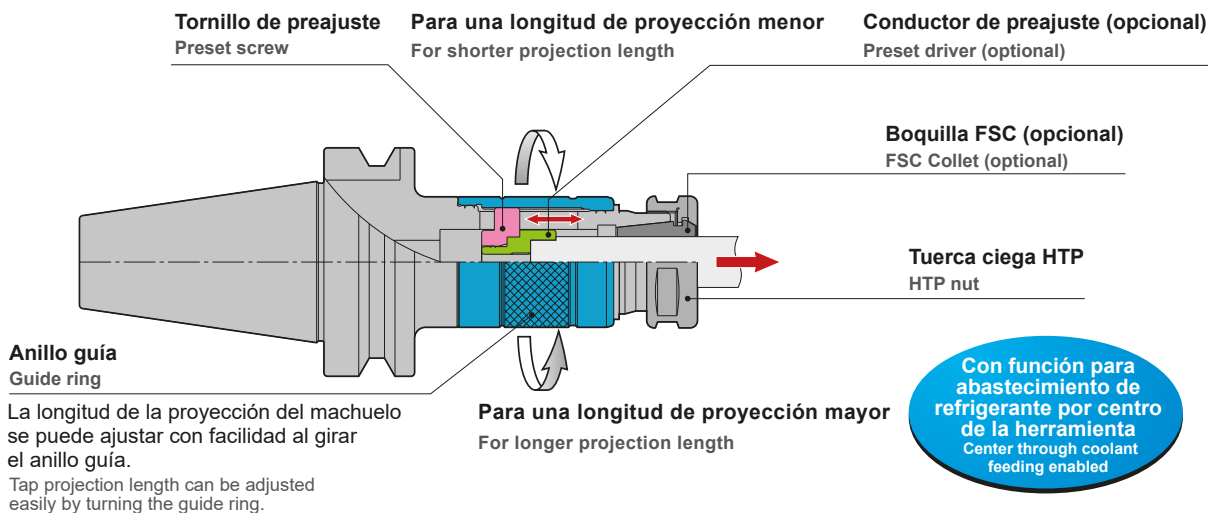

Suministro de refrigerante - Coolant supply

■ Abastecimiento de refrigerante interno habilitado.

Presión máxima del refrigerante:
Diámetro del zanco de la herramienta 19 mm por debajo de: 7 MPa 20 mm y superior a: 5 MPa (la boquilla para refrigerante se vende por separado) (NOTA) La presión del refrigerante para el UTS es diferente.

■ Internal coolant feeding enabled.

Maximum coolant pressure:
Tool shank diameter 19mm and below: 7MPa
20mm and above: 5MPa (Coolant collet is sold separately)
(NOTE) Coolant pressure for UTS is different.



Cortador con vena de lubricación
Tipo FSC-OH
Cutter with oil hole
FSC-OH type



Para refrigerante por costados de la boquilla
Tipo FSC-C
For collet through coolant
FSC-C type

Collet Holder **HDC•A & GDC•A**

Adecuado para barrenado, rimado y acabado en fresa.

Suitable for drilling, reaming and finish endmilling.

Tipo de alta presión
High Precision Type

HDC•A

BT.....pág. 074
CAT.....pág. 200
AHO.....pág. 252
HSK•A.....pág. 302
UTS.....pág. 418



Tipo de alto balance
High Balanced Type

GDC•A

BT.....pág. 080
CAT.....pág. 204
HSK•A.....pág. 306



La precisión de la boquilla de categoría AA (rango de sujeción: 0.5 - 22.0 mm) está dentro de los 5 micrómetros en 4d.

Chucking accuracy of AA grade collet (chucking range: 0.5-22.0mm) is within 5 micrometers at 4d.

Tornillo de preajuste

Preset screw

HDS-※※型 標準仕様
Standard

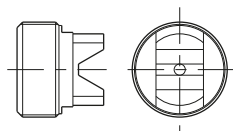

El operador puede ajustar la longitud de proyección de la herramienta de corte desde la tuerca ciega.

The operator can adjust the projection length of the cutting tool from the cap end.

HDS-※※-※型 六角穴付仕様 (別売 option)
with hex. hole

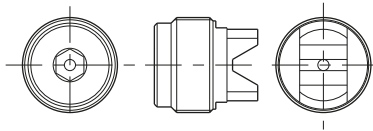

El operador puede ajustar la longitud de proyección de la herramienta de corte con una llave Allen desde el lado del zanco del portaherramienta.

The operator can adjust the projection length of the cutting tool by using a hexagon wrench from the holder shank side.

HDS-※※-MS型 セミドライ加工用 (別売 option)
For semi-dry machining

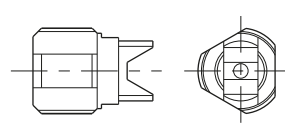

Para mecanizado semiseco. El operador puede ajustar la longitud de proyección de la herramienta de corte con una llave Allen desde el lado del zanco del portaherramienta.

For semi-dry machining. The operator can adjust the projection length of the cutting tool by using a hexagon wrench from the holder shank side.

El HDC-A viene con un tornillo de preajuste estándar. Puede comprar un tornillo de preajuste separado para el HDC-A y el GDC-A, de acuerdo a varios requisitos.
The HDC-A comes with a standard preset screw. You may purchase a preset screw separately for the HDC-A and GDC-A according to various requirements.

Suministro de refrigerante

Coolant supply



Herramienta con vena de lubricación
Tipo FDC-OH
8,000 m i n⁻¹
6 MPa
Tool with oil hole
FDC-OH type
8,000 m i n⁻¹
6 MPa



Para refrigerante por los costados de boquilla
Tipo FDC-C
8,000 m i n⁻¹
6 MPa
For coolant through coolant
FDC-C type
8,000 m i n⁻¹
6 MPa

Herramienta para sujeción - BCL

Tool Clamper - BCL



BCLpág. 535

La tuerca ciega y el tornillo de retención pueden ser apretados con un solo modelo de BCL para los portaherramientas en zanco BT
Both caps and retention studs of BT shank tool holders can be tightened on one clamper!

Floating Collet Type FH-ST-HDC•A

Adecuado para rimados de alta precisión.

Suitable for High Precision Reaming.

Tipo de boquilla Collet type

Rimas con diferentes medidas de zanco pueden ser sujetadas al intercambiar la boquilla.

Reamers with various shank sizes can be clamped by replacing the collet.

La cantidad de flote puede ser ajustada Floating amount can be adjusted.

- ※Excepciones en determinadas medidas.
- * Except a specific size.

La función de retención incorporada previene que la rima se hunda en los husillos horizontales.
Built-in locking function prevents reamer from sagging on horizontal spindles.

Portaherramienta
flotante para uso con boquilla
Collet Type Floating Holder
FH-ST-HDC•A

ST.....pág. 517



El mecanismo de flote angular y radial compensa la variación de alineamiento entre la rima y el orificio previamente barrenado.
Radial and angular float mechanism compensates for misalignment between reamer and pre-drilled hole.

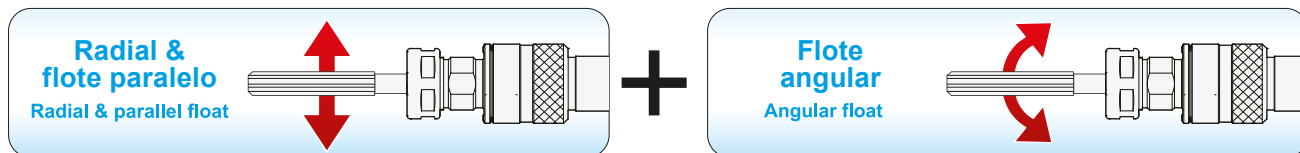

Se pueden utilizar rimas con/sin cuadro en el zanco.
Can be used with reamers with/without square end.

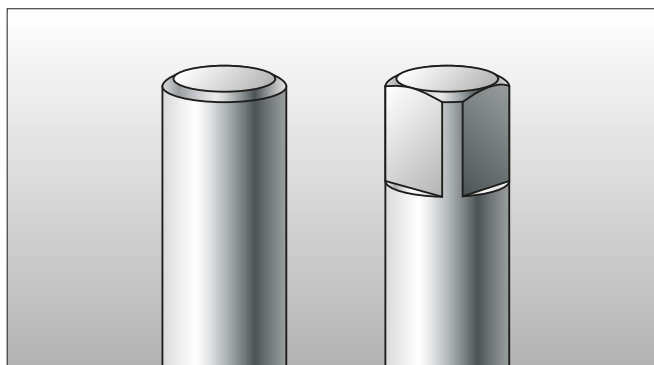

Suministro de refrigerante
Coolant supply



Cortador con vena de lubricación
Cutter with oil hole
Tipo FDC-OH
FDC-OH type



Para refrigerante por costados de la boquilla
For collet through coolant
Tipo FDC-C
FDC-C type

- ※ Para alimentación de refrigerante a través del centro de la herramienta, contactar a NT TOOL para verificar las condiciones de corte.
- ※ For center through coolant feed, please contact NT TOOL beforehand for cutting conditions.

Boquillas para mecanizado semiseco (MQL)



Collets For Semi-dry Machining (MQL)

FDC-MS

La boquilla FDC-MS se utiliza con mecanizado semiseco con un portaherramienta para boquilla.

FDC-MS type is a collet used for semi-dry machining with a collet holder.

FSC-MS

La boquilla FSC-MS se utiliza para mecanizado semiseco con portaherramientas para machuelo.

FSC-MS type is a collet used for semi-dry machining with a tapping chuck.

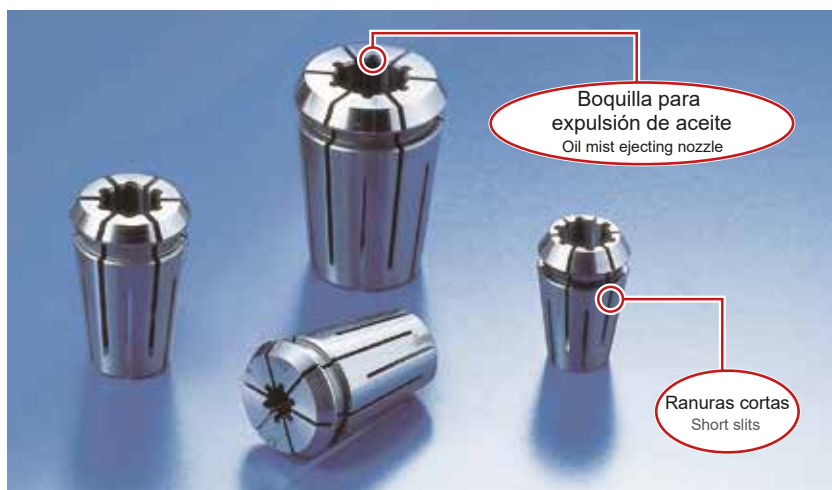

¿Qué es el mecanizado semiseco? What's semi-dry machining?

El mecanizado semiseco es un proceso también conocido como MQL (Minimum Quantity Lubrication), es un método de mecanizado en el cual una pequeña cantidad de lubricante se nebuliza con aire comprimido.

Semi-dry machining, also known as MQL (Minimum Quantity Lubrication), is a machining method in which a small amount of cutting lubricant is nebulized with compressed air.

Amigable con el medio ambiente
Eco-friendly

Previene la contaminación ambiental, debido a que minimiza el uso del aceite para cortadores.

Prevent environmental pollution by minimized used of cutting oil.

Disminución de costo
Cost down

Reducción en el uso de lubricantes. Costes de control de concentración y eliminación de residuos líquidos.

Reduced lubricant use trims cost for concentration control and liquid waste disposal.

Limpieza
Cleanliness

La lubricación de calidad mínima ayuda a frenar la contaminación, como la fuga de aceite en la planta.

Minimum quality lubrication helps to restrain contamination such as oil leak in the plant.

Portaherramientas para boquillas MQL

Tool holders for MQL collets

FDC-MS

SDM



HDC•A



GDC•A



"R" Zero

HDZ

GDZ



KH-EC



FSC-MS

STM



Lubricación simultánea del borde de corte y la cara lateral de la herramienta

Simultaneous lubrication of cutting edge and tool lateral face

El vapor de aceite que emana de los orificios de la boquilla lubrica el borde de la herramienta de corte y remueve las virutas de material.

Oil mist from oil holes of the tool lubricates the cutting edge and remove chips.

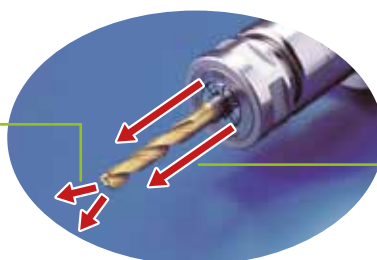

El vapor de aceite que emana de la boquilla lubrica los costados de la herramienta de corte prolongando el tiempo de vida de la misma.

Oil mist from the collet holes lubricates the side edge and prolongs the tool life.

Características Features

■ Sellado perfecto

Las ranuras cortas que posee la boquilla previene los derrames.

■ Perfect sealing

The short slit on collet prevents leakage.

■ Boquillas para rocío de vapor de aceite

Boquillas con un diseño y forma calculadas para optimizar el rocío del refrigerante.

■ Oil mist spraying nozzles

Calculated nozzle shape for optimum spray.

《Patentado》 Efectividad de la boquilla con función de rocío de vapor de aceite 《Patented》 Effectiveness of oil mist spray nozzle

Hace que el lubricante se adhiera a la superficie de la pieza de trabajo y de la herramienta al rociar partículas comparativamente grandes junto a la herramienta.

Making lubricant adhere to the surface of workpiece and tool by spraying comparatively large particles alongside the tool.

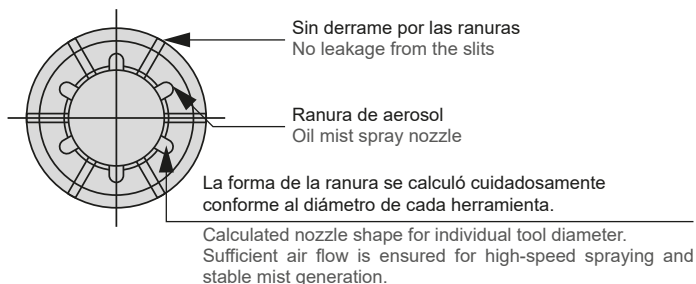
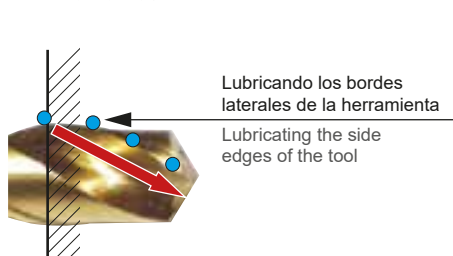
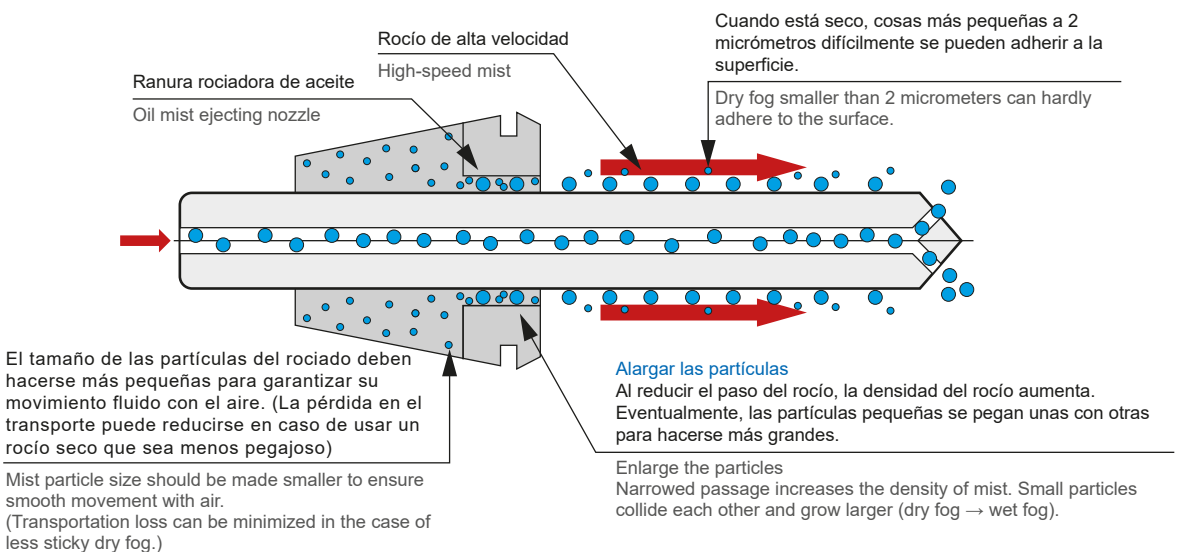

Ejemplo de corte con función semiseca Semi-dry cutting example

Trabajo: profundidad del orificio (L/D=20)
Broca: 5mm diámetro, broca larga con vena de lubricación
Work : Non-step deep hole (L/D=20)
Drill : 5mm dia. long drill with oil hole

Viruta
Chip



Superficie de trabajo
Work surface

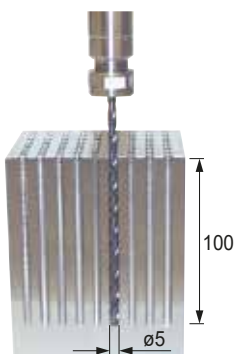

Condiciones de corte		Cutting condition
Portaherramienta Tool holder	BT30-HDZ09-75	FDC-05009-MS
Pieza de trabajo Workpiece	SCM440	HRC40
Herramienta Cutting tool	Broca sólida de carburo con vena de lubricación Solid carbide drill with oil hole ø5 × 180 Longitud 130mm	
Refrigerante Coolant	Semiseco (a través del centro) Semi Dry (Center through) MRC21 Lubricación 0.5cc/min Temperatura 5~10cc/min	
Velocidad Cutting speed	V=80m/min (N=5040/min)	
Suministro Feed	f=0.1mm/rev (F=504mm/min)	
Profundidad Hole depth	100mm (ノンステップ) 100mm (Non-step drilling)	
Tiempo de Ciclo Cycle time	12segundo / 1orificio (exceptuando los tiempos para realizar orificios guía) 12 seconds/hole (time for making guide holes excepted.)	

Fixed & Angle Head AH, AHS & AHL

Flexible type



Tipo fijo
Fixed type

AH
AH-OH

- AH 90°**
BTpág. 170
AHOpág. 292
- AHE 90°**
CATpág. 240
HSK-Apág. 263
- AH 45°**
BTpág. 172
AHOpág. 294



Tipo flexible
Flexible type

AHS
AHL

- AHS, AHL**
BTpág. 174
- AHSE, AHLE**
CATpág. 242
HSK-Apág. 365

●Tipo flexible: se puede establecer cualquier ángulo de inclinación a su discreción.

●Flexible type:
Any tilt angle can be set at your discretion.



●El abastecimiento de refrigerante por centro está habilitado. El primer sistema interno de refrigerante estandarizado en el mundo que permite el abastecimiento de refrigerante a detalle en el sitio deseado.

●Center through coolant feeding is possible. World's first standardized internal coolant system, which enables pin-point coolant supply to the desired place.

Tipo con refrigerante - Coolant type

El tipo fijo es capaz de abastecer refrigerante internamente como lo tiene establecido. Todo lo que tiene que hacer para habilitar el abastecimiento del refrigerante a través del centro es agregar una unidad refrigerante y una boquilla con función refrigerante.

Fixed type is capable of supplying coolant internally as it is. All you have to do to enable center-through coolant feeding is to add a coolant unit and a coolant collet.

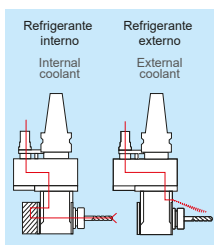

Especificaciones - Specifications

Tipo Type	Velocidad máxima de rotación Max. rotational speed	Capacidad de sujeción Chucking capacity	Capacidad de machueado Tapping capacity	Ángulo de inclinación Tilt angle	Refrigerante interno Internal coolant
Tipo flexible Flexible type	3,000min ⁻¹	φ 0.5~φ 22	M3~M22	0°~90°	
Tipo sólido 45 Solid type 45	07 size 6,000min ⁻¹ other 3,000min ⁻¹	φ 0.5~φ 16	M3~M22	45°	Sí / Yes
Tipo sólido 90 Solid type 90	07 size 6,000min ⁻¹ other 3,000min ⁻¹	φ 0.5~φ 25	M3~M22	90°	Sí / Yes

Lineamientos para las condiciones de corte (en el tipo fijo)

Guidelines for cutting conditions (Fixed type)

Herramienta - Tool	Acabado en fresa HSS de 2 flautas (diá. 10 mm) 2-flute HSS endmill (dia. 10mm)			Acabado en fresa HSS de 2 flautas (diá. 20 mm) 2-flute HSS endmill (dia. 20mm)		
	S55C	FC250	A2017	S55C	FC250	A2017
Material de trabajo - Work material	S55C	FC250	A2017	S55C	FC250	A2017
Profundidad del corte (mm) - Depth of cut (mm)	11	12	11	4	5	5
Velocidad de rotación (min-1) - Rotational speed (min ⁻¹)	630	1,000	2,000	400	500	1,000
Velocidad del corte (mm/min) - Cutting speed (m/min)	20	40	63	25	31	63
Alimentación (mm/min) - Feed (mm/min)	60	100	200	60	50	100
Alimentación por rotación (mm/rev) - Feed per rotation (mm/rev)	0.09	0.1	0.1	0.15	0.1	0.1

Reducción de costos en inversión de la planta

Reduction of plant investment

- Sin usar una mesa de inclinación, se puede mecanizar desde diferentes ángulos. Se puede reducir el costo de configuración y la inversión de la planta.
- El tipo fijo tiene mayor rigidez que el tipo flexible.
- Without using a tilt table, machining from different angles can be performed. Set-up cost and plant investment cost can be reduced.
- Fixed type has a much higher rigidity than flexible type.

Accesorio de machueado de cambio rápido
Quick-change tapping attachment

Compresión F2 Tensión F1
Compression F2 Tension F1

con adaptador de machuelo tipo WE adjunto (opcional)
with WE type tap adapter attached (optional)

Tipo Type	Medida del adaptador del machuelo Tap adapter size	Capacidad de machueado Tapping capacity	Medidas de longitud Length dimensions				Compensación axial Axial compensation			
			L1	L2	L3	L4	φ D1	φ D2	F1	F2
TPC16-1	1	(M15) U1/4~U7/16 (U9/16) PIPE (PT,PS,PF) 1/8~1/4	50	56.5	64.5	121	32	36		
TPC22-1	1	M8~M22 U3/8~U7/8	69	80	71	150	50	46	10	2
TPC22-2	2	M8~M22 U3/8~U7/8	69	80	71	150	50	46		

Speed increaser HP-H

Incrementador de velocidad
Speed increaser

HP-H

BT.....pág. 169

CAT.....pág. 239

30,000min⁻¹



Ventajas - Advantages

- Aumenta las revoluciones del maquinado y reduce el tiempo del ciclo.
 - Máximo 30,000 min⁻¹.
 - Garantiza poco ruido y vibración por los engranes de precisión de acero.
 - Se pueden ajustar zancos tan pequeños que pueden medir de 0.5 mm (0.02 in) (serie FDC 07) hasta 12 mm (0.472 in) (serie FDC 12).
 - Se previene el sobrecalentamiento gracias a un ventilador de enfriamiento turbo.
- Increases tooling revolutions, and reduces cycle time.
 - Maximum 30,000 min⁻¹.
 - Assures low noise and vibration by precision ground steel gears.
 - Tool shanks as small as 0.5mm(0.02in)(FDC 07 series), up to 12mm(0.472in)(FDC 12 series) can be chucked.
 - Overheating is prevented by a cooling turbo fan.

Sus máquinas actuales

Your Current Machines

+

Hyper Spindles

=

5 veces más rápido
5 times faster

Los hyper spindles aumentan las revoluciones de mecanizado hasta 5 veces más (máximo 30,000 min⁻¹), lo que permite reducir el costo por pieza con sus máquinas actuales, en lugar de instalar nuevas.

Hyper spindles increase tooling revolutions up to 5 times higher (maximum 30,000min⁻¹), enabling you to reduce per-piece cost with your current machines instead of installing new machines.

Datos de corte - Cutting data

	BT50-HP07H-150	BT50-HP07H-150	BT50-HP12H-165
Material de trabajo - Work material	Aleaciones de aluminio (A2017) - (A2017) aluminium alloys		
(mín -1) Revoluciones - Revolution	30,000		
Alimentación-Feed (mm/min) Feed (in/min)	1200 (47.28)	900 (47.28)	1200 (47.28)
Diámetro del fresado (mm) Mil dia (in)	6.0 (0.24)	3.0 (0.12)	12.0 (0.47)
Profundidad del corte Depth of cut	<p>Acabado en fresa (HSS) de 2 flautas Two-flute endmill (HSS)</p>	<p>Acabado en fresa de carburo de 2 flautas Two-flute carbide endmill</p>	<p>Acabado en fresa de carburo de 2 flautas Two-flute carbide endmill</p>

Torque recomendado Recommended tightening torque

Medida Size	Llave Inglesa para tuerca ciega Spanner for cap	Llave Inglesa para cabezal del zanco Spanner for head shank	Valor de torque recomendado Recommended torque value
HP07H	S - 0	16 mm	10~15N•m (80~133lbf-in)
HP09H	S - 1L	21 mm	30~35N•m (266~310lbf-in)
HP12H	S - 3L	21 mm	35~40N•m (310~354lbf-in)

Velocidad máxima de rotación y precisión de la sujeción Maximum rotational speed and chucking accuracy

Medida Size	Medida de la boquilla Collet size	Rango de velocidad Speed ratio	Velocidad máxima Max. speed	Precisión de la sujeción Chucking accuracy
HP07H	FDC07	1 : 5	30,000min ⁻¹ (M/C6,000min ⁻¹)	10µm/4D (0.4µin/4D)
HP09H	FDC09			
HP12H	FDC12			

Portaherramienta BT de doble contacto, Ligero y eficiente

Lightweight, Efficient & Two-face Contact Bt Holder

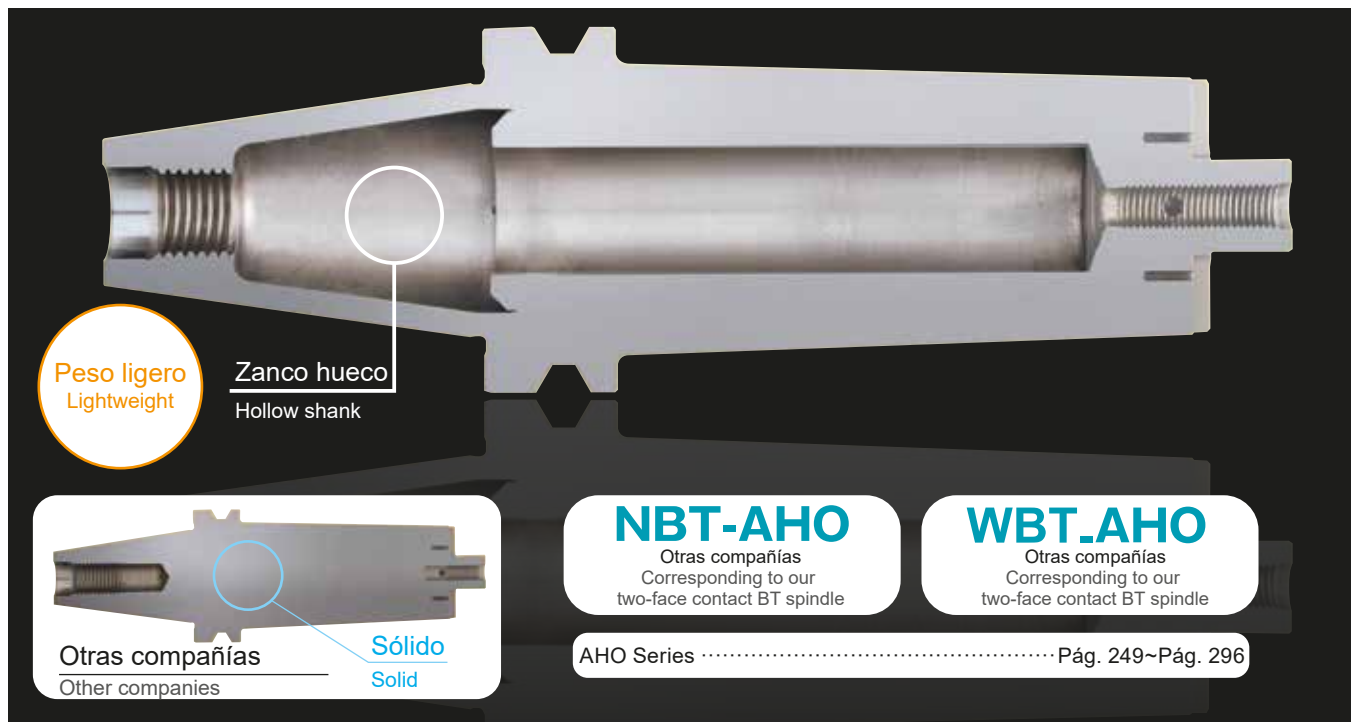

Peso ligero
Lightweight

Zanco hueco
Hollow shank

Otras compañías
Other companies

Sólido
Solid

NBT-AHO

Otras compañías
Corresponding to our
two-face contact BT spindle

WBT-AHO

Otras compañías
Corresponding to our
two-face contact BT spindle

AHO Series Pág. 249~Pág. 296

Ventajas del sistema AHO

Advantages of AHO

Un portaherramienta ligero reduce la carga en el husillo y mejora la eficiencia de la energía.

Lightweight holder reduces load to spindle, and improves energy efficiency.

El portaherramienta se aligera al hacer hueco el zanco. Al usar el portaherramienta ligero reduce la carga en el husillo y mejora la eficiencia de la energía. El zanco ahusado de BT50 pesa 4 kg→2.8 kg

The holder is made lighter by hollowing out the shank. Use of lightweight holder reduces load to spindle, and improves energy efficiency. Taper shank of BT50 4kg→2.8kg

Tasa de remoción de viruta: 20-50% ó MÁS ALTA Chip removal rate: 20-50% UP

El doble contacto y el balance sostenido ideal del zanco cónico y el reborde logra aumentos sorprendentes en el desempeño.

Two-face contact and ideal sustaining balance of taper and flange achieves remarkable increase of performance.

Doble contacto perfecto, incluso cuando hay rotación a alta velocidad

Perfect two-face contact even at high-speed rotation

Incluso cuando el husillo de la máquina se expande por la fuerza centrífuga, se mantiene el doble contacto.

Even when the machine spindle expands with centrifugal force, two-face contact is maintained.

Alta precisión por repeticiones

High repetitive accuracy

La zona ahusada del portaherramienta se contrae junto al zanco cónico del husillo. Además, la cara del reborde entra en contacto cercano con el husillo y hace una unión precisa.

Taper area of tool holder shrinks along spindle taper. In addition, flange face tightly contacts to the spindle, and realizes precise attachment.

Inhibición del desgaste

Inhibition of fretting

El contacto continuo entre el zanco cónico y el husillo de la máquina evita el desgaste.

Continuous contact between the taper and the end face prevents fretting.

Mecanismo de sujeción AHO

Clamp mechanism of AHO

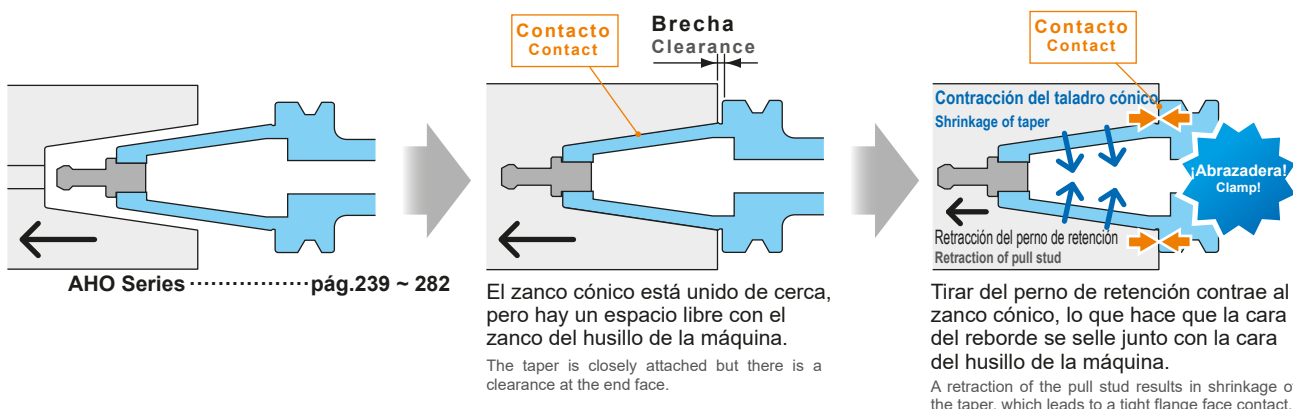

Comparación en cuanto al desempeño de corte

Cutting performance comparison with normal BT

Mecanizado en fresa / Face-milling

Condiciones de corte Cutting conditions

	BT40	BT50
Portaherramienta Tool Holder	BT40-FMA31.75-75 (Estándar/Standard BT,AHO)	BT50-FMA38.1-165 (Estándar/Standard BT,AHO)
Cortador Cutting	ø100 Face mill cutter (5 Hoja de corte/Blade)	ø125 Face mill cutter (6 Hoja de corte/Blade)
Viruta Chip	SDKN42MT (A30N)	XDMT120408PDEN (ACZ350)
Material Cutting Material	S50C	SKD11
Velocidad de rotación Rotation speed	480min ⁻¹	250min ⁻¹
Suministro Feed speed	480mm/min	300mm/min
Método de corte Cutting method	Corte inferior / Down cut	
Refrigerante Cutting fluid	No (Corte en seco / Dry cut)	
Capacidad de corte Cutting capacity	Determinado en función de la presencia o ausencia de vibración en la superficie de corte Determined based on the presence or absence of chatter on the cutting surface	
Método de prueba Test method	Detenga el corte hasta que se produzca el chirrido en la superficie de corte, incremente el proceso. Realice esta prueba cinco veces bajo las mismas condiciones. Las virutas de metal se renuevan en cada ocasión. Stop the cutting until the chatter occurs on the cutting surface. Increase it. Perform this test five times under the same conditions. Chips are used brand new each time.	

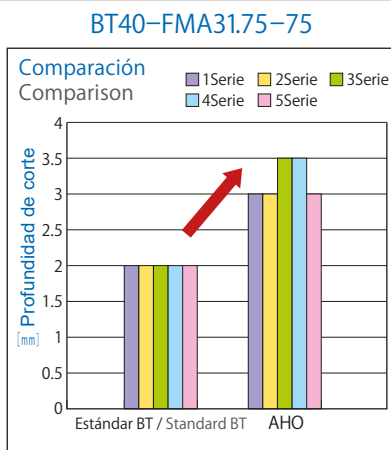

Comparado con el BT
regular aumenta en un 38%
Higher than normal BT by 38%

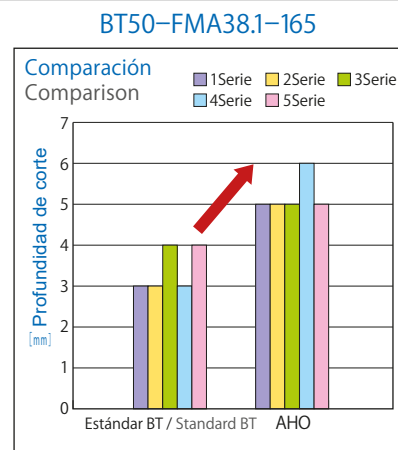

Comparado con el BT
regular aumenta en un 53%
Higher than normal BT by 53%

Dimensiones del zanco AHO

AHO spindle dimension

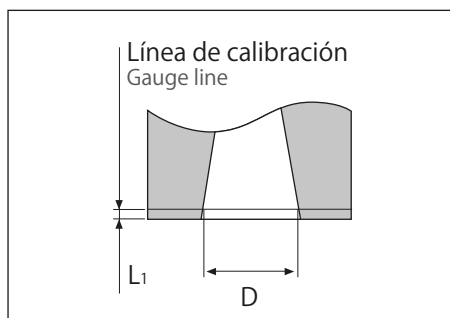

BT	D	※L ₁	
		NBT-AHO	WBT-AHO
30	31.75	0.2	0.98
40	44.45	0.2	0.98
50	69.85	0.2	1.48

※La tolerancia del L₁ varía según la medida del husillo.
※Tolerance of L₁ varies depending on the spindle size.

Es fácil hacer un husillo
Easy to make a spindle

Favor de contactarnos cuando fabrique un husillo
Please contact us when making spindles.

Multibore Tooling System

Una gama completa de herramientas para diversas aplicaciones

A complete range of tools for various applications

Herramientas para mandrilado Boring tools

**Zanco maestro
Master shank**

Para/For BT
BT30~BT50

Para/For AHO
NBT-AHO30~NBT-AHO50
WBT-AHO30~WBT-AHO50

For HSK•A
HSK50A~HSK63A

Para/For Polygon (C)
C5, C6

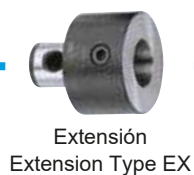

Twin cutter head
Tipo / Type TWA, TWB
Diámetro de corte / Cutting diameter: 29-205mm

Single cutter head
Tipo / Type SGA, SGB
Diámetro de corte / Cutting diameter: 29-205mm

Fine boring head
Tipo / Type FBA
Diámetro de corte / Cutting diameter: 20-130mm

Fine boring head
Tipo / Type FBB
Diámetro de corte / Cutting diameter: 100-205mm

Micro fine boring head
Tipo / Type PFB
Diámetro de corte / Cutting diameter: 6-30mm

Single boring head
Tipo / Type SBA
diámetro de corte / Cutting diameter: 20-30mm

Herramientas para fresado y barrenado Milling and drilling tools

**Zanco maestro
Master shank**

Para/For BT
BT30~BT50

Para/For AHO
NBT-AHO30~NBT-AHO50
WBT-AHO30~WBT-AHO50

For HSK•A
HSK50A~HSK63A

Para/For Polygon (C)
C5, C6



Con función para boquilla / Collet chuck head
Tipo / Type HDC-W
Rango de sujeción / Chucking range: 0.5-25mm

Side lock head
Tipo / Type SL2
Diámetro de la herramienta / Tool diameter: 6-40 mm

Face milling head
Tipo / Type FMA-W
Shell mill head
Tipo / Type SM-W

Turning Tools for **SPEEDIO M140X1**



Inoxidable Rustproof
*Pueden aplicar algunas excepciones
* Some exceptions apply

Con función de abastecimiento de refrigerante disponible
Coolant, Feeding, Enabled

SBH

SBV

TSB

Para Refrentado
For Facing
SBH
SBH...pág.188
□20

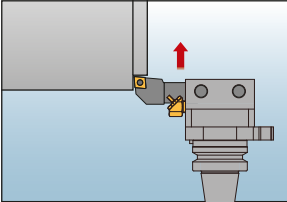

Para Refrentado/Exterior
For External / Facing
SBV
SBV...pág.181
□20

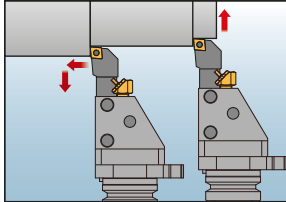

Para Barra mandriladora
For Boring bar
TSB
TSB...pág.385
φ 10, 12, 16, 20

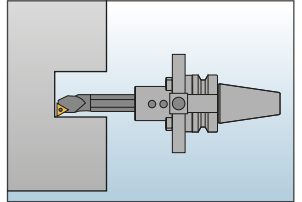

Puede usarse para
Use for

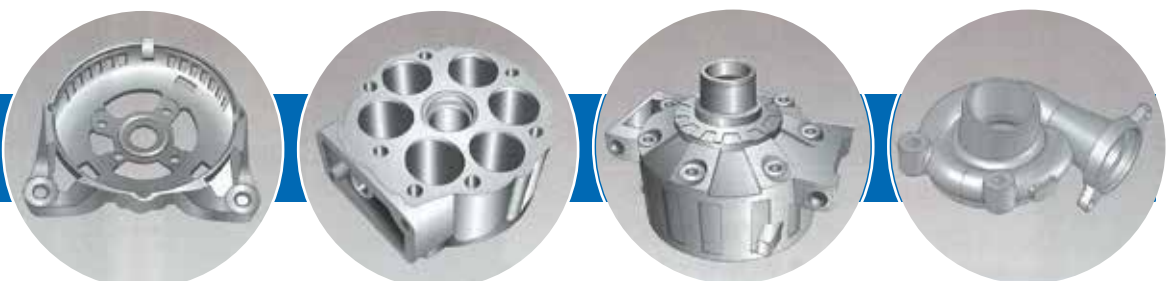

SPEEDIO M140X1

Centro de torneado + Centro de mecanizado
Turning center + Machining center

Nuevas opciones para la integración de los procesos
New Choice for Process Integration



HSK • T Turning Tools

¿Qué es HSK-T?

La interfaz HSK-T se desarrolló para maximizar la habilidad de corte de las máquinas multitareas.

La interfaz HSK-T obtuvo el estándar ISO (ISO121 164-3:2008) en el 2008.

What is HSK-T?

HSK-T interface was developed to maximize cutting ability of multi-tasking machines.

HSK-T interface became ISO standard (ISO121 164-3:2008) in 2008.



Inoxidable
Rustproof

*Pueden aplicar algunas excepciones
* Some exceptions apply

Con función de abastecimiento de refrigerante disponible

Coolant, Feeding, Enabled

Para el Corte/Exterior
For External/Cut-off

SBV

SBV.....pág.381

□20, □25, □32

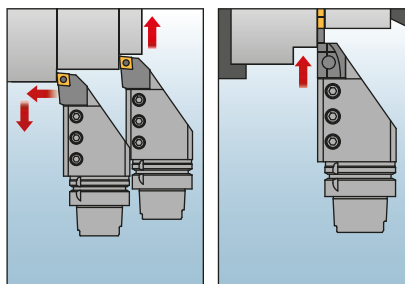

Para el Refrentado/ Exterior
For External/Facing

SBT

SBT.....pág.384

□20, □25

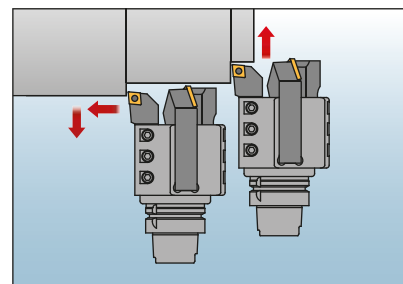

Para el Refrentado/ Exterior
For External/Facing

SBN

SBN.....pág.382

□20, □25, □32

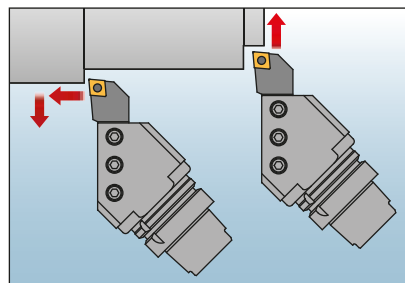

Para Barra mandriladora
For Boring bar

TSB

TSB.....pág.385

ø8-50

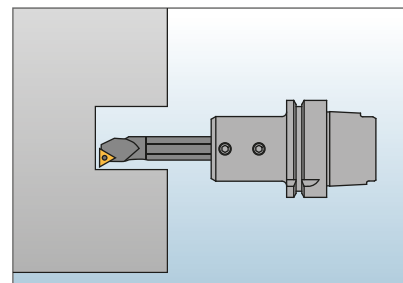

Para Refrentado
For Facing

SBH

SBH.....pág.383

□20, □25, □32

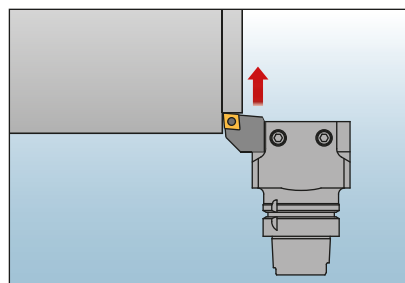

Para Barrenado
For Drill

TSD

TSD.....pág.387

ø16-50

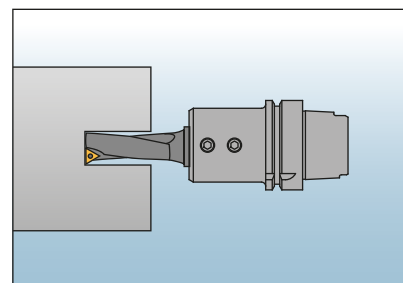

MORI SEIKI CO., LTD le otorgó a NT TOOL una autorización para fabricar y distribuir bajo la patente No.3720202.
MORI SEIKI CO.,LTD granted NT TOOL a manufacturing and distribution license under the patent No.3720202.

Contactless Optical Tool Presetter

¡Fácil de usar!

Diseño operativo bien pensado para la operación

Easy to use!
Well thought out operational design.

Contactless Optical Tool Presetter

AOTP

AOTP.....pág.528



Las especificaciones y el diseño del producto están sujetos a cambios sin notificación previa.
Specifications and design of the product are subject to change without notice.

Cuerpo Mecánico amigable con el usuario - User Friendly Mechanical Body



Manija de la cámara.
Camera Handle

Manejo simple con una sola mano, movimiento en ejes "X" y "Z" por separado o simultáneamente.
Simple one hand operation. Movable in X-axis direction or Z-axis direction separately/simultaneously.



Z-axis



X-axis

Perilla de ajuste fino para eje "X" y "Z".
Fine Adjustment Dial for Z-axis / X-axis

Ajuste preciso de la cámara al rotar la perilla de ajuste fino.
Quick camera positioning by rotating the dial.



Brazo de cámara.
Camera Arm.

Medición posible hasta un diámetro máximo de 400 mm.
Measurement up to dia.400mm is possible.



Realizar el ajuste de un portaherramienta de boquillas es posible de hacer directo en el husillo (hasta maximo 60 Nm). (Retirar la cámara del husillo para evitar golpearla).
Tightening of a collet holder is possible. (Up to 60Nm) Move away the camera from the spindle when tightening.

El ajuste de la longitud de proyección y excentricidad de la herramienta de corte puede realizarse en un mismo lugar.
Adjustment of cutting tool projection length and runout measurement / adjustment can be done in one spot.



Impresora de etiquetas (opcional)
Label printer (Optional)

Impresora térmica. No necesita cartuchos. Se puede imprimir el valor medido.
Se puede imprimir el nombre de la herramienta, el modelo y los comentarios registrados previamente en conjunto.
Thermal printer. No cartridges needed. Measured value can be printed. Tool name, model, comment registered beforehand can be printed together.

Sujeción mecánica.
Mechanical Clamp.

El cilindro de aire sujeta un portaherramientas firmemente de hasta 400 kg. Se cuenta con una buena precisión al colocar o retirar el portaherramientas repetidamente.
400kg air cylinder firmly clamps the tool holder. Good repetitive accuracy of tool holder clamping/unclamping.



Ajuste de longitud de proyección de la herramienta de corte (opcional).
Cutting Tool Projection Length Adjustment (Optional)

Puede añadirse de manera opcional una manija operativa para ajustar la longitud de las herramientas de corte.
An operation handle for cutting tool projection length adjustment can be added.

Software de fácil uso con función de tutorial - Easy-to-use Software with Tutorial Function.

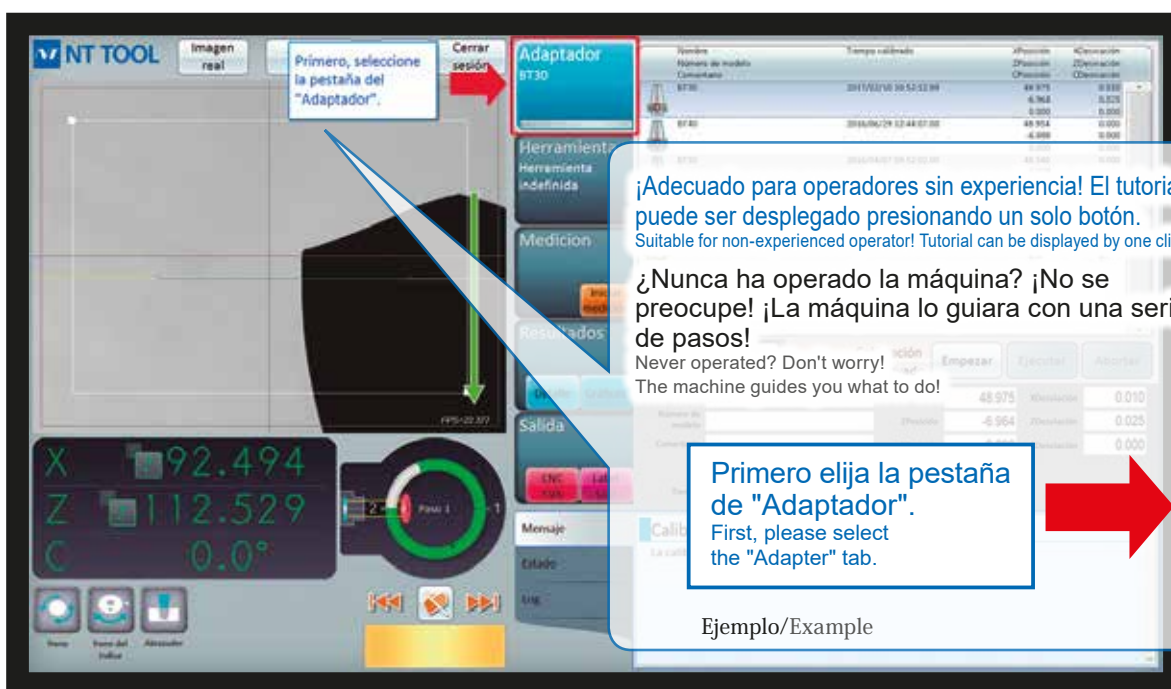

Funciones Básicas - Basic Function

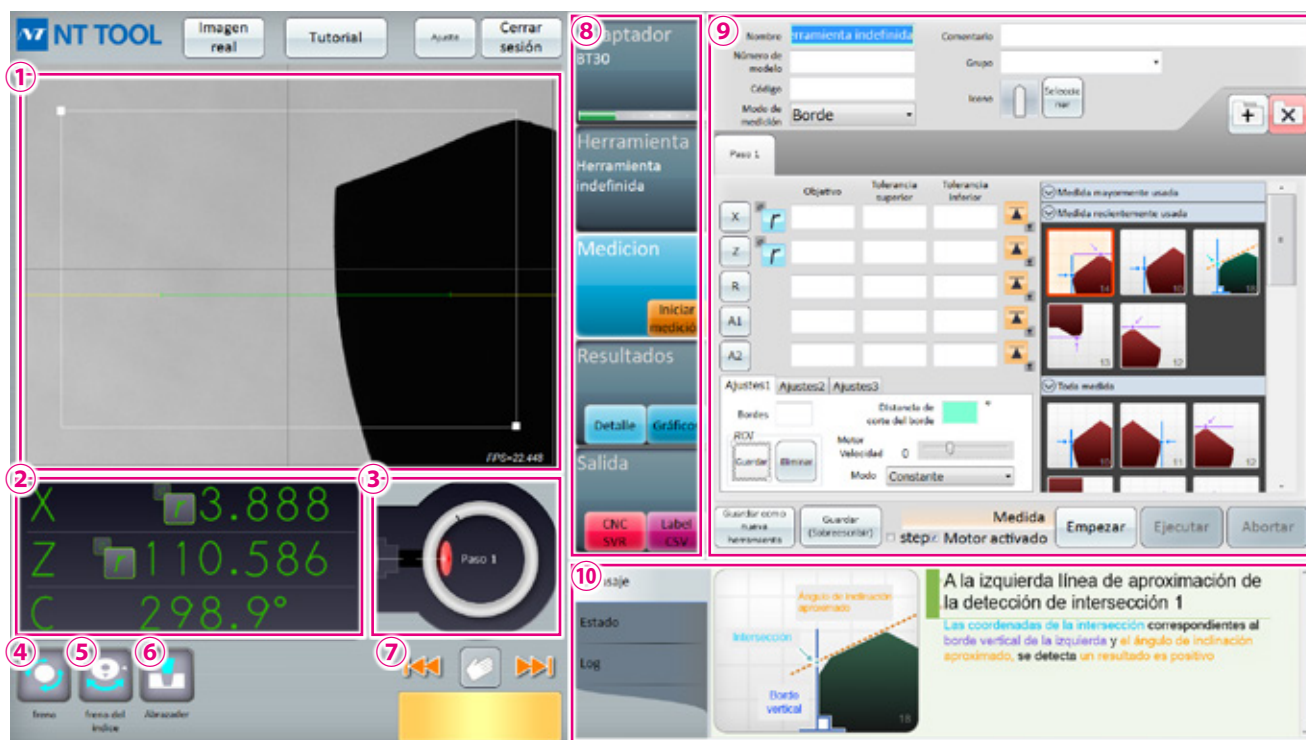

1 Cámara (imagen capturada) 1 Camera (Captured Image)

Campo de visión 9.0 mm x 6.5 mm
Ampliación de 30x
Zoom digital de 35x
Actual field of view 9.0mm x 6.5mm
30x Magnification
35x Digital Zoom

2 Coordenadas 2 Coordinates

X= radio/diámetro, Z= altura,
C= posición rotatoria.
*El valor de X y Z indican la posición del centro de la cámara cuando no se está midiendo.
X=Radius/Diameter, Z=Height, C=Rotational Position.
*X and Z value indicates position of the camera center when not measuring.

3 Ojo mágico 3 Magic Eye

Detección del borde de corte
Cutting edge detection

4 Freno 4 Break

El husillo se puede detener en cualquier ubicación.
Spindle can be stopped at any location.

5 Freno del indicador 5 Index Break

El husillo se puede bloquear a los 90 grados.
Spindle can be pin-locked at 90 degrees.

6 Sujetar/Soltar 6 Clamp / Unclamp

7 Control de husillo 7 Spindle Control

Adelante / regresarse al siguiente / anterior al borde de corte.
Forward / reverse to the next / previous cutting edge.
[Icon] : Liberar el motor.
[Icon] : Free the motor.

8 Pestaña de la orden de operación 8 Operation Order Tab

9 Campo de operación 9 Operation Field

10 Campo de mensaje 10 Message Field

El software se puede personalizar bajo pedido. Favor de contactar a NT Tool Méx.
The software can be customized upon request. Please contact NT Tool.

Contactless Optical Tool Presetter



Contactless Optical Tool Presetter

SOTP

SOTPpág.532

¡Simple y compacto!
Pre seteadora de alto rendimiento
¡Precio accesible!

Simple and Compact!
High-performance presetter
Affordable price!

- **Medición sin contacto con la herramienta, por lo que no se dañan los bordes de corte de la herramienta.**

Contactless measurement so the cutting edges are not damaged.

Adecuado para herramientas de corte costosas, como diamante y CBN

Suitable for expensive cutting tools such as diamond and CBN.

Por su operación sencilla ayuda a reducir errores humanos - Easy operation reduces human errors



Sujeción mecánica

Mechanical Clamping

Un cilindro neumático sujeta el portaherramientas de una manera segura en su lugar, garantizando una excelente precisión durante los repetidos montajes de los portaherramientas.

A pneumatic cylinder clamps the holder securely in place, guaranteeing excellent accuracy through repeated mounting of holders.



Perilla de ajuste fino para eje "X" y "Z"

Fine Adjustment Dial for Z-axis / X-axis

Ajuste rápido y preciso de la cámara al rotar la perilla de ajuste fino.

Quick camera positioning by rotating the dial.



Medición

Measurement

X-eje : \varnothing 300mm X-axis : \varnothing 300mm

Z-eje : \varnothing 400mm Z-axis : \varnothing 400mm

"R" Zero Setter

SPZ-2

SPZ-2 pág.538

Aplicación / Característica

Application / Feature

- Menos de 3 μm de precisión a 200 mm (HSK, UTS)
- Base de portaherramienta giratorio para BT, HSK, UTS
- Mecanismo de tracción del portaherramienta

- Less than 3 μm runout accuracy at 200mm(HSK, UTS)
- Rotary holder support for BT, HSK, UTS.
- Holder pull-in mechanism.



Simple Setter

SPHV-3

SPHV-3 pág.539

Aplicación / Característica

Application / Feature

- Diseño ligero y compacto. Puede colocarse en la mesa de trabajo.
- Se adoptan escalas digitales tanto para ejes X como para ejes Z.

- Light weight and compact design. Placeable on work table.
- Digital scales adopted for both X axis and Z axis.



Abrazadera HSK- HSK Clamper

SPN1-HSK

SPN1-HSK pág.536

Aplicación / Característica

Application / Feature

- Portaherramienta fácil de sujetar al insertar el zanco HSK (A, C o T) y girar la perilla 90 grados
- Es posible medir la longitud de la herramienta

- Easy to clamp holder as just insert HSK (A, C, or T) shank and rotate knob 90 degrees.
- Tool length measurement is possible.



HCL

HCL pág.537

Aplicación / Característica

Application / Feature

- Recomendado para ajustar portaherramienta de fresado o portaherramienta de boquilla.
- Se pueden sujetar todos los tipos de HSK (A-F y T) y UTS.
- Se pueden sujetar diferentes zancos con adaptadores ADS.
- El portaherramienta se puede sujetar sólo al girar la palanca de sujeción. La palanca de sujeción puede girar en ambos lados.
- Un tapete de vinilo evitará causar daños en el zanco cónico o en la cara del reborde del zanco HSK / UTS.
- Best suited for tightening milling chucks or collet chucks.
- All types of HSK (A-F, and T) and UTS can be clamped.
- With ADS adaptors, various different shanks can be clamped.
- Tool holder can be clamped by turning the clamp lever only. The clamp lever can be turned in either direction.
- Vinyl mat will prevent damages to taper or flange face of HSK / UTS shank.



Sólo cuerpo
Body only



Adaptador cuerpo + ADS
Body + ADS Adapter



CAT40

Collet Holder Type - MDE

Nuevo producto de NT TOOL como el resultado de nuestra búsqueda por...

New from NT TOOL after our quest for...

¡Facilidad de uso!

Ease of use!

¡Alta precisión!

High accuracy!

¡Buen costo-beneficio!

Good value for money!



NT MEVIUS..... pág.246

Alta precisión

High accuracy

$4d = 7\mu m!$



Gran fuerza de sujeción

Strong Clamping Force

Recubrimiento anti corrosión

Rust Proof Black Coating

El cuerpo entero del portaherramienta tiene un recubrimiento obscurecido contra el óxido.

The holder body is entirely black oxide coated.





B T

BT (MAS 403-1982)
SISTEMA DE HERRAMENTADO
TOOLING SYSTEM

Super tite-lock Milling Chuck

- Super tite-lock Milling Chuck delgado. Sus ranuras tienen un diseño especial para permitir desbastes pesados.
- Slim design milling chuck. Specially designed slits enable heavy endmilling.

BT

CAT

AHO

HSK-A/E/F/C

HSK-T

C

UTS

Máquinas

Especializadas

Specialized

Machine

Equipo

Relacionado

Related

Equipment

Taladro de

Biselado &

Casquillo

Bush &

Chamfering

Drill

Milling Chuck

Collet Holder

"R" Zero Holder

Hydraulic

Chuck

Shrink Fit

Tapping Chuck

Ahrs

Function

Holder

Turning Tool

Retention Stud

Tool Shank

Dimensions

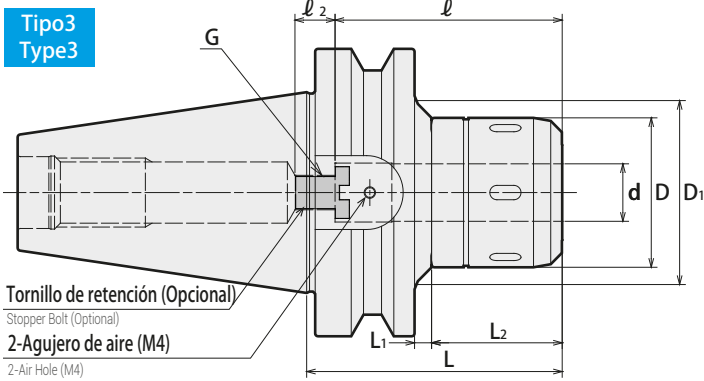
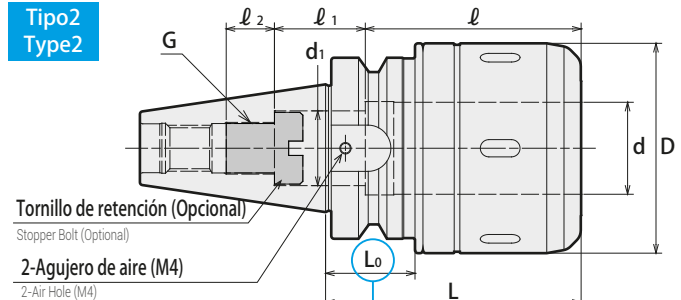
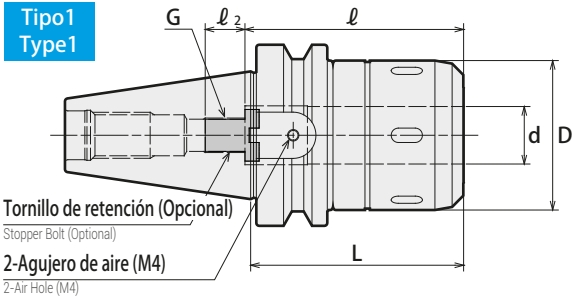

⚠ Precaución/Caution
Tenga precaución, revise que no tenga interferencia el brazo A.T.C. (automatic tool changer) y el cartucho de herramientas.
Take caution against A.T.C. arm and tool magazine interference.

Precaución/Caution
Favor de girar el anillo de sujeción en sentido contrario a las manecillas del reloj por más de 360 grados después de remover una herramienta de corte.
Please rotate the clamping ring counterclockwise more than 360 degrees after a cutting tool is removed.

Medida en Pulgadas - Inch Sizes																Unidad : Pulgadas Unit : Inch	
Código Code	Modelo Model	Tipo Type	d	D	D1	L	L1	L2	ℓ	ℓ1	ℓ2	d1	L0	G P=1.0	kg	Llave Inglesa Spanner	
3140 50124075	BT30 -CT0750SA -75	2	0.750	2.047	—	2.953	—	—	2.559	—	0.591	—	1.063	M12	1.0	HS-2-20	
3140 50124090	-90	2	0.750	2.047	—	3.543	—	—	3.150	—	0.591	—	1.654	M12	1.4		
3140 50124105	-105	2	0.750	2.047	—	4.134	—	—	3.150	—	0.591	—	2.244	M12	1.4		
3140 50132090	BT30 -CT1000SA -90	2	1.000	2.402	—	3.543	—	—	3.150	—	0.591	—	1.142	M12	1.4	HS-2.5-25	
3140 50132105	-105	2	1.000	2.402	—	4.134	—	—	3.150	—	0.591	—	1.732	M12	1.6		
3140 50324075	BT40 -CT0750SA -75	1	0.750	2.047	—	2.953	—	—	2.953	—	0.591	—	—	M12	1.6		
3140 50324090	-90	3	0.750	2.047	2.283	3.543	0.709	1.772	3.150	—	0.591	—	—	M12	1.8	HS-2-20	
3140 50324105	-105	3	0.750	2.047	2.283	4.134	1.299	1.772	3.150	—	0.591	—	—	M12	2.0		
3140 50324120	-120	3	0.750	2.047	2.283	4.724	1.890	1.772	3.150	—	0.591	—	—	M12	2.2		
3140 50332090	BT40 -CT1000SA -90	1	1.000	2.402	—	3.543	—	—	3.150	—	0.591	—	—	M12	2.0	HS-2.5-25	
3140 50332105	-105	1	1.000	2.402	—	4.134	—	—	3.150	—	0.591	—	—	M12	2.3		
3140 50332120	-120	1	1.000	2.402	—	4.724	—	—	3.150	—	0.591	—	—	M12	—		
3140 50332135	-135	1	1.000	2.402	—	5.315	—	—	3.150	—	0.591	—	—	M12	—		
3140 50340090	BT40 -CT1250SA -90	2	1.250	2.874	—	3.543	—	—	2.992	1.260	0.669	1.024	1.220	M18	2.3	HS-3-32	
314050340105	-105	2	1.250	2.874	—	4.134	—	—	3.346	0.906	0.669	1.024	1.811	M18	2.6		
3140 50340120	-120	2	1.250	2.874	—	4.724	—	—	3.346	0.906	0.669	1.024	2.402	M18	2.9		
3140 50340135	-135	2	1.250	2.874	—	5.315	—	—	4.724	—	0.669	1.024	2.992	M18	3.1		
3140 50524090	BT50 -CT0750SA -90	3	0.750	2.047	2.559	3.543	0.276	1.772	3.150	—	0.591	—	—	M12	—	HS-2-20	
3140 50524105	-105	3	0.750	2.047	2.677	4.134	0.866	1.772	3.150	—	0.591	—	—	M12	4.5		
3140 50524135	-135	3	0.750	2.047	3.150	5.315	2.047	1.772	3.150	—	0.591	—	—	M12	—		
3140 50532105	BT50 -CT1000SA -105	3	1.000	2.402	3.228	4.134	0.433	2.205	3.150	—	0.591	—	—	M12	4.7	HS-2.5-25	
3140 50532135	-135	3	1.000	2.402	3.268	5.315	1.614	2.205	3.150	—	0.591	—	—	M12	—		
3140 50532165	-165	3	1.000	2.402	3.386	6.496	2.795	2.205	3.150	—	0.591	—	—	M12	—		

Medida en Pulgadas - Inch Sizes

Unidad : Pulgadas
Unit : Inch

Código Code	Modelo Model	Tipo Type	d	D	D1	L	L1	L2	ℓ	ℓ1	ℓ2	d1	L0	G P=1.0	kg	Llave Inglesa Spanner
3140 50540095	BT50 -CT1250SA -95	1	1.250	2.874	—	3.740	—	—	4.724	—	0.787	—	—	M18		HS-3-32
3140 50540105	-105	3	1.250	2.874	3.386	4.134	0.433	2.205	4.724	—	0.787	—	—	M18	5.0	
3140 50540120	-120	3	1.250	2.874	3.425	4.724	1.024	2.205	4.724	—	0.787	—	—	M18		
3140 50540135	-135	3	1.250	2.874	3.386	5.315	1.614	2.205	4.724	—	0.787	—	—	M18	6.1	
3140 50540150	-150	3	1.250	2.874	3.465	5.906	2.205	2.205	4.724	—	0.787	—	—	M18		
3140 50540165	-165	3	1.250	2.874	3.465	6.496	2.795	2.205	4.724	—	0.787	—	—	M18	7.1	
3140 10564105	BT50 -CT2000SA -105	2	2.000	4.134	—	4.134	—	—	3.937	—	0.787	—	1.654	M18		HS-4V
3140 10564120	-120	2	2.000	4.134	—	4.724	—	—	3.937	—	0.787	—	2.244	M18	7.1	
3140 10564135	-135	2	2.000	4.134	—	5.315	—	—	3.937	—	0.787	—	2.835	M18		
3140 10564150	-150	2	2.000	4.134	—	5.906	—	—	3.937	—	0.787	—	3.425	M18		
3140 10564165	-165	2	2.000	4.134	—	6.496	—	—	3.937	—	0.787	—	4.016	M18		

- Use 2 piezas de los tornillos opresores (incluidos) M4 x 5 (S) para cerrar los orificios vacíos en el portaherramienta cuando se use la refrigeración interna.
- Al hacer su orden, indique el número de llaves inglesas que requiere. Las llaves inglesas "son gratuitas" y están limitadas al número de portaherramientas de fresado de su orden.
- La tolerancia del zanco de las herramientas de corte deben estar dentro de h7.
 - Use 2pcs. of M4 x 5 (S) hex. screw (included) to close air holes on the holder when internal coolant is used.
 - When ordering, indicate number of spanners required. "No charge" spanners are limited to number of milling chucks on order.
 - Tolerance of cutting tool shank must be h7.

Ejemplo para Ordenar - Ordering Example

BT30 - CT 0750 SA - 75

Interfaz y diámetro de husillo Shank size	Diámetro Interior I.D. (d)	Longitud de Proyección Projection length (L)
--	-------------------------------	---

Llave Inglesa Spanner
Pág. 073



Accesorios Accessories

Tornillo de retención Stopper Bolt BL (Pág.072)	Boquilla recta Straight Collet MC (Pág.070) MCA (Pág.071)	Adaptador Morse Morse Taper Adapter MA (Pág.072) MAB (Pág.072)	Adaptador Jacobs Jacobs Adapter JA (Pág.073) JAB (Pág.073)
--	--	---	---

Longitud Mínima de inserción Min. chucking length

Sin boquilla MC Without MC collet		Unidad : Métrico Unit : Metric
D.I. del portaherramienta de fresado I.D. of Milling Chuck	Longitud mín de inserción Min. chucking length	
16, 20	40	
25, 32, 42	50	

Con boquilla MC With MC collet		Unidad : Métrico Unit : Metric	
D.I. de la boquilla Collet I.D.	Longitud mín de inserción Min. chucking length		
	MC	MC-C, MC-OH	
6, 8	30	30	
10, 12	40	40	
16, 20	45	45	
25	50	50	
32	50	60	

Sin boquilla MC Without MC collet		Unidad : Pulgadas Unit : Inch
D.I. del portaherramienta de fresado I.D. of Milling Chuck	Longitud mín de inserción Min. chucking length	
0.750"	1.575" (40mm)	
1.000", 1.250"	1.969" (50mm)	
2.000"	2.170" (55mm)	

Con boquilla MC With MC collet		Unidad : Pulgada Unit : Inch	
D.I. de la boquilla Collet I.D.	Longitud mín de inserción Min. chucking length		
	MC, MC-C, MC-OH		
1/4, 5/16	1.181" (30mm)		
3/8, 1/2	1.575" (40mm)		
5/8, 3/4, 7/8	1.772" (45mm)		
1, 1-1/4, 1-1/2	1.969" (50mm)		

Super tite-lock Milling Chuck

- Milling chuck delgado. Sus ranuras tienen un diseño especial para permitir desbastes pesados.
- Slim design milling chuck. Specially designed slits enable heavy endmilling.

Tipo1
Type1

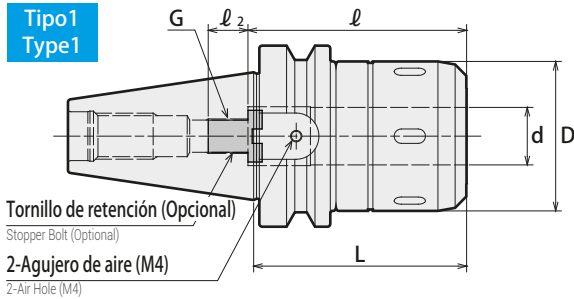

Tipo2
Type2

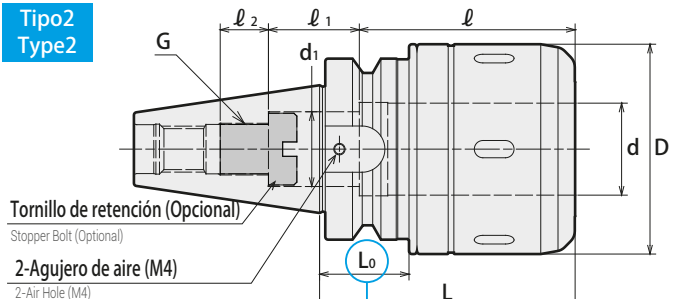

Tipo3
Type3

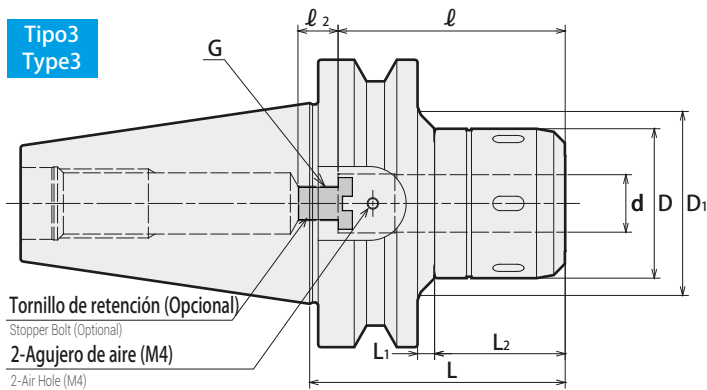

⚠ Precaución/Caution

Tenga precaución, revise que no tenga interferencia el brazo A.T.C. (automatic tool changer) y el cartucho de herramientas.
Take caution against A.T.C. arm and tool magazine interference.

Precaución/Caution

Favor de girar el anillo de sujeción en sentido contrario a las manecillas del reloj por más de 360 grados después de remover una herramienta de corte.

Please rotate the clamping ring counterclockwise more than 360 degrees after a cutting tool is removed.

Medidas Métricas - Metric Sizes

Unidad : Métrico
Unit : Metric

Código Code	Modelo Model	Tipo Type	d	D	D ₁	L	L ₁	L ₂	ℓ	ℓ ₁	ℓ ₂	d ₁	L ₀	G P=1.0	Max. min ⁻¹	kg	-	Llave Inglesa Spanner
3140 40116075	BT30 -CT16SA -75	1	16	45	-	75	-	-	65	-	15	-	-	M10	16,000	0.9	35,520	
3140 40116090	-90	1	16	45	-	90	-	-	65	-	15	-	-	M10	16,000	1.1	35,520	HS-1-16
3140 40120075	-CT20SA -75	* 1	20	52	-	75	-	-	65	-	15	-	★ 27	M12	15,000	1.0	35,520	
3140 40120090	-90	2	20	52	-	90	-	-	80	-	15	-	40	M12	14,000	1.2	35,520	HS-2-20
3140 40120105	-105	2	20	52	-	105	-	-	80	-	15	-	55	M12	12,000	1.3	35,520	
3140 40125090	-CT25SA -90	2	25	61	-	90	-	-	80	-	15	-	★ 31	M12	11,000	1.4	37,740	
3140 40125105	-105	2	25	61	-	105	-	-	80	-	15	-	44	M12	10,000	1.6	38,300	HS-2.5-25
3140 40132090	-CT32SA -90	2	32	68	-	90	-	-	68	-	20	-	★ 30	M18	8,000	1.6	41,070	HS-3-32
3140 40316075	BT40 -CT16SA -75	1	16	45	-	75	-	-	65	-	15	-	-	M10	20,000	1.4	37,060	
3140 40316090	-90	1	16	45	-	90	-	-	65	-	15	-	-	M10	20,000	1.6	37,060	HS-1-16
3140 40320075	-CT20SA -75	1	20	52	-	75	-	-	75	-	15	-	-	M12	18,000	1.5	37,060	
3140 40320090	-90	1	20	52	-	90	-	-	80	-	15	-	-	M12	18,000	1.8	37,060	
3140 40320105	-105	1	20	52	-	105	-	-	80	-	15	-	-	M12	18,000	2.1	39,240	HS-2-20
3140 40320120	-120	1	20	52	-	120	-	-	80	-	15	-	-	M12	18,000	2.3	40,330	
3140 40325090	-CT25SA -90	1	25	61	-	90	-	-	80	-	15	-	-	M12	16,000	2.0	39,240	
3140 40325105	-105	1	25	61	-	105	-	-	80	-	15	-	-	M12	16,000	2.3	40,330	
3140 40325120	-120	1	25	61	-	120	-	-	80	-	15	-	-	M12	16,000	2.7	40,330	HS-2.5-25
3140 40325135	-135	1	25	61	-	135	-	-	80	-	15	-	-	M12	14,000	3.0	40,330	
3140 40332090	-CT32SA -90	* 2	32	73	-	90	-	-	76	32	17	26	★ 31	M18	12,000	2.3	41,070	
3140 40332105	-105	* 3	32	73	-	105	-	-	85	23	17	26	44	M18	12,000	2.5	41,070	
3140 40332120	-120	* 3	32	73	-	120	-	-	85	23	17	26	59	M18	12,000	2.9	43,290	HS-3-32
3140 40332135	-135	2	32	73	-	135	-	-	120	-	17	-	74	M18	12,000	3.2	43,290	

Medidas Métricas - Metric Sizes





Unidad : Métrico
Unit : Metric

Código Code	Modelo Model	Tipo Type	d	D	D ₁	L	L ₁	L ₂	ℓ	ℓ ₁	ℓ ₂	d ₁	L ₀	G P=1.0	Max. min ⁻¹	kg	-	Llave Inglesa Spanner
3140 40516090	BT50 -CT16SA -90	3	16	45	58	90	7	45	65	—	20	—	—	M10	15,000	4.1	44,520	
3140 40516105	-105	3	16	45	70	105	22	45	65	—	20	—	—	M10	15,000	4.4	44,520	HS-1-16
3140 40516135	-135	3	16	45	70	135	52	45	65	—	20	—	—	M10	15,000	5.0	44,520	
3140 40520090	-CT20SA -90	3	20	52	65	90	7	45	80	—	15	—	—	M12	15,000	4.2	44,520	
3140 40520105	-105	3	20	52	70	105	9	58	80	—	15	—	—	M12	15,000	4.5	44,520	HS-2-20
3140 40520120	-120	3	20	52	70	120	24	58	80	—	15	—	—	M12	15,000	4.9	44,520	
3140 40520135	-135	3	20	52	73	135	39	58	80	—	15	—	—	M12	14,000	5.4	44,520	
3140 40520165	-165	3	20	52	73	165	69	58	80	—	15	—	—	M12	13,000	6.1	48,700	
3140 40520200	-200	3	20	52	73	200	104	58	80	—	15	—	—	M12	12,000	6.8	50,700	
3140 40520250	-250	3	20	52	73	250	154	58	80	—	15	—	—	M12	10,000	7.9	52,700	
3140 40520300	-300	3	20	52	73	300	204	58	80	—	15	—	—	M12	7,000	9.3	56,700	
3140 40525105	-CT25SA -105	3	25	61	82	105	11	56	80	—	15	—	—	M12	14,000	4.8	47,700	
3140 40525120	-120	3	25	61	82	120	26	56	80	—	15	—	—	M12	13,000	5.2	47,700	HS-2.5-25
3140 40525135	-135	3	25	61	83	135	41	56	80	—	15	—	—	M12	12,000	5.7	47,700	
3140 40525165	-165	3	25	61	86	165	71	56	80	—	15	—	—	M12	11,000	6.6	49,820	
3140 40525200	-200	3	25	61	86	200	106	56	80	—	15	—	—	M12	10,000	7.7	51,700	
3140 40525250	-250	3	25	61	86	250	156	56	80	—	15	—	—	M12	9,000	9.2	53,700	
3140 40525300	-300	3	25	61	86	300	206	56	80	—	15	—	—	M12	8,000	10.8	57,700	
3140 40532095	-CT32SA -95	1	32	73	—	95	—	—	120	—	20	—	—	M18	12,000	4.6	49,820	
3140 40532105	-105	1	32	73	—	105	—	—	120	—	20	—	—	M18	12,000	4.9	49,820	HS-3-32
3140 40532120	-120	3	32	73	87	120	26	56	120	—	20	—	—	M18	12,000	5.6	51,940	
3140 40532135	-135	3	32	73	88	135	41	56	120	—	20	—	—	M18	12,000	6.2	51,940	
3140 40532150	-150	3	32	73	87	150	56	56	120	—	20	—	—	M18	11,000	6.7	54,060	
3140 40532165	-165	3	32	73	86	165	71	56	120	—	20	—	—	M18	10,000	7.2	54,060	
3140 40532200	-200	3	32	73	88	200	106	56	120	—	20	—	—	M18	9,000	8.6	57,200	
3140 40532250	-250	3	32	73	88	250	156	56	120	—	20	—	—	M18	8,000	10.5	59,200	
3140 40532300	-300	3	32	73	88	300	206	56	120	—	20	—	—	M18	7,000	12.4	60,000	
3140 40542095	-CT42SA -95 * 4	1	42	88	—	95	—	—	120	—	20	—	—	M18	10,000	5.0	56,180	
3140 40542105	-105 * 4	1	42	88	—	105	—	—	120	—	20	—	—	M18	10,000	5.4	56,180	HS-4-42
3140 40542120	-120	1	42	88	—	120	—	—	120	—	20	—	—	M18	10,000	6.1	56,180	
3140 40542135	-135	1	42	88	—	135	—	—	120	—	20	—	—	M18	10,000	6.8	58,300	
3140 40542150	-150	1	42	88	—	150	—	—	120	—	20	—	—	M18	10,000	7.4	58,300	
3140 40542165	-165	1	42	88	—	165	—	—	120	—	20	—	—	M18	9,000	8.1	60,420	
3140 40542200	-200	1	42	88	—	200	—	—	120	—	20	—	—	M18	8,000	9.7	62,700	
3140 40542250	-250	1	42	88	—	250	—	—	120	—	20	—	—	M18	7,000	12.0	63,700	
3140 40542300	-300	1	42	88	—	300	—	—	120	—	20	—	—	M18	6,000	14.2	67,700	

- Use 2 piezas de los tornillos Allen/opresores (incluidas) M4 x 5 (S) para cerrar los orificios vacíos en el portaherramienta cuando se use el refrigerante interno.
 - Al hacer su orden, indique el número de llaves inglesas que requiere. Las llaves inglesas "son gratuitas" y están limitadas al número de portaherramientas de fresado de su orden.
 - La tolerancia del zanco de las herramientas de corte debe estar dentro de h7.
 - La velocidad permitida varía mucho según la rigidez del husillo en la máquina y del balance de la herramienta de corte. Aumente gradualmente la velocidad a partir de la baja y úselo en la velocidad adecuada.
- Use 2pcs. of M4 x 5 (S) hex. screw (included) to close air holes on the holder when internal coolant is used.
 - When ordering, indicate number of spanners required. "No charge" spanners are limited to number of milling chucks on order.
 - Tolerance of cutting tool shank must be h7.
 - Permissible speed is greatly affected by the stiffness of the machine spindle and the balance of the cutting tool. Gradually increase from a low speed, and use at the proper speed.

Accesorios Accessories

Los modelos con * 1- * 4 no pueden usarse con algunos accesorios debido a la corta ℓ longitud.
Models with * 1 - * 4 cannot be used with some accessories due to short ℓ length.

	Tornillo de retención Stopper Bolt 	Boquilla recta Straight Collet 		Adaptador Morse Morse Taper Adapter 		Adaptador Jacobs Jacobs Adapter 	
	BL (Pág.072)	MC (Pág.070)	MCA (Pág.071)	MA (Pág.072)	MAB (Pág.072)	JA (Pág.073)	JAB (Pág.073)
* 1	Sí / Yes	Sí / Yes	No	No	No	No	No
* 2	Sí / Yes	Sí / Yes	No	No	Sí / Yes	No	Sí / Yes
* 3	Sí / Yes	Sí / Yes	Sí / Yes	No	Sí / Yes	No	Sí / Yes
* 4	Sí / Yes	Sí / Yes	No	Sí / Yes	Sí / Yes	Sí / Yes	Sí / Yes

Longitud Mínima de Inserción Min. chucking length

Sin boquilla MC
Without MC collet

Unidad : Métrico
Unit : Metric

Con boquilla MC
With MC collet

Unidad : Métrico
Unit : Metric

D.I. del portaherramienta de fresado I.D. of Milling Chuck	Longitud mín de inserción Min. chucking length	D.I. de la boquilla Collet I.D.	Longitud mín de inserción Min. chucking length	
			MC	MC-C, MC-OH
16, 20	40	6, 8	30	30
25, 32, 42	50	10, 12	40	40
		16, 20	45	45
		25	50	50
		32	50	60

Llave Inglesa
Spanner
Pág. 073

Ejemplo para Ordenar - Ordering Example

BT30 - CT 16 SA - 75

Interfaz y
diámetro
de husillo

Diámetro
Interior

Longitud de
Proyección

Shank size

I.D. (d)

Projection
length (L)

Pulgada a métrico → Pulgada × 25.4

Métrico a pulgada → Métrico ÷ 25.4 ó métrico por 0.03937



Tamaños especiales / personalizados bajo pedido

BT

BT

CAT

AHO

HSK-A/E/F/C

HSK-T

C

UTS

Máquinas Especializadas
Specialized Machine

Equipo Relacionado
Related Equipment

Taladro de Biselado & Casquillo
Bush & Chamfering Drill

Milling Chuck

Collet Holder

"R" Zero Holder

Hydraulic Chuck

Shrink Fit

Tapping Chuck

Arbors

Function Holder

Turning Tool

Retention Stud

Tool Shank Dimensions

CT·SA-CF

Super Tite-Lock Milling Chuck (Flange Through Type)

- Super Tite-Lock Milling Chuck con función refrigerante por centro. Conforme a DIN69871 Formulario B
- Flange through coolant type milling chuck. DIN69871 Form B compliance.

BT

CAT

AHO

HSK-A/E/F/C

HSK-T

C

UTS

Máquinas

Especializadas

Specialized

Machine

Equipo

Relacionado

Related

Equipment

Taladro de

Biselado &

Casquillo

Bush &

Chamfering

Drill

Milling

Chuck

Collet

Holder

"R" Zero

Holder

Hydraulic

Chuck

Shrink

Fit

Tapping

Chuck

Anchors

Function

Holder

Turning

Tool

Retention

Stud

Tool

Shank

Dimensions

Tipo1
Type1

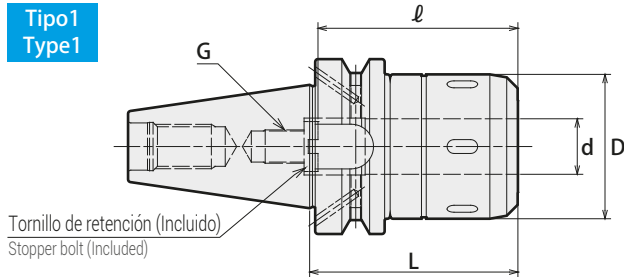

Tipo2
Type2

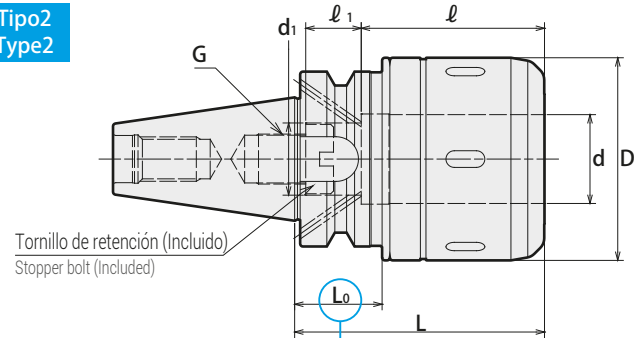

Tipo3
Type3

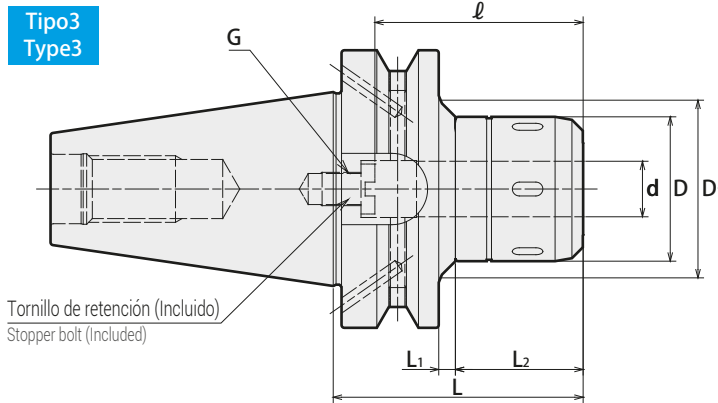

⚠ Precaución/Caution

- ★ : Tenga precaución, revise que no tenga interferencia el brazo A.T.C. (automatic tool changer) y el cartucho de herramientas.
Take caution against A.T.C. arm and tool magazine interference.

Precaución/Caution

- Favor de girar el anillo de sujeción en sentido contrario a las manecillas del reloj por más de 360 grados después de remover una herramienta de corte.
Please rotate the clamping ring counterclockwise more than 360 degrees after a cutting tool is removed.

- DIN69871 Formulario B
- Presión máxima del refrigerante: 7 MPa
- DIN69871 Form B
- Max. Coolant pressure : 7MPa

Medidas Métricas - Metric Sizes

Unidad : Métrico
Unit : Metric

Código Code	Modelo Model	Tipo Type	d	D	D1	L	L1	L2	ℓ	ℓ	d1	L0	G P=1.0	Max. min ⁻¹	Kg	-	Llave Inglesa Spanner
3146 40316075	BT40 -CT16SA -75CF	1	16	45	—	75	—	—	60	—	—	—	10	20,000	1.5	44,690	
3146 40316090	-90CF	1	16	45	—	90	—	—	60	—	—	—	10	20,000	1.6	44,690	HS-1-16
3146 40320075	-CT20SA -75CF	1	20	52	—	75	—	—	65	—	—	—	12	18,000	1.6	46,870	
3146 40320090	-90CF	1	20	52	—	90	—	—	75	—	—	—	12	18,000	1.8	46,870	HS-2-20
3146 40320105	-105CF	1	20	52	—	105	—	—	75	—	—	—	12	18,000	2.0	46,870	
3146 40320120	-120CF	1	20	52	—	120	—	—	75	—	—	—	12	18,000	2.3	47,960	
3146 40325090	-CT25SA -90CF	1	25	61	—	90	—	—	75	—	—	—	12	16,000	2.0	46,870	
3146 40325105	-105CF	1	25	61	—	105	—	—	75	—	—	—	12	16,000	2.4	47,960	HS-2.5-25
3146 40325120	-120CF	1	25	61	—	120	—	—	75	—	—	—	12	16,000	2.7	47,960	
3146 40325135	-135CF	1	25	61	—	135	—	—	75	—	—	—	12	14,000	3.1	47,960	
3146 40332090	-CT32SA -90CF	2	32	73	—	90	—	—	70	—	—	★ 31	18	12,000	2.4	47,960	
3146 40332105	-105CF	2	32	73	—	105	—	—	75	—	—	44	18	12,000	2.7	47,960	HS-3-32
3146 40332120	-120CF	2	32	73	—	120	—	—	85	5	26	59	18	12,000	3.0	50,140	
3146 40332135	-135CF	2	32	73	—	135	—	—	90	13	26	74	18	12,000	3.3	50,140	
3146 40516090	BT50 -CT16SA -90CF	3	16	45	58	90	7	45	65	—	—	—	10	15,000	4.2	53,000	HS-1-16
3146 40516105	-105CF	3	16	45	70	105	22	45	60	—	—	—	10	15,000	4.5	53,000	
3146 40520090	-CT20SA -90CF	3	20	52	65	90	7	45	80	—	—	—	12	15,000	4.3	53,000	
3146 40520105	-105CF	3	20	52	70	105	9	58	80	—	—	—	12	15,000	4.6	53,000	HS-2-20
3146 40520120	-120CF	3	20	52	70	120	24	58	80	—	—	—	12	15,000	4.8	53,000	
3146 40520135	-135CF	3	20	52	73	135	39	58	80	—	—	—	12	14,000	5.3	53,000	
3146 40525105	-CT25SA -105CF	3	25	61	82	105	11	56	80	—	—	—	12	14,000	4.9	56,180	
3146 40525120	-120CF	3	25	61	82	120	26	56	80	—	—	—	12	13,000	5.3	56,180	HS-2.5-25
3146 40525135	-135CF	3	25	61	83	135	41	56	80	—	—	—	12	12,000	5.8	56,180	
3146 40525165	-165CF	3	25	61	86	165	71	56	80	—	—	—	12	11,000	6.9	58,300	

Pulgada a métrico → Pulgada × 25.4

Métrico a pulgada → Métrico ÷ 25.4 ó métrico por 0.03937



Tamaños especiales / personalizados bajo pedido

Medidas Métricas - Metric Sizes

Unidad : Métrico
Unit : Metric

Código Code	Modelo Model	Tipo Type	d	D	D1	L	L1	L2	ℓ	ℓ	d1	L0	G P=1.0	Max. min ⁻¹	Kg	-	Llave Inglesa Spanner
3146 40532095	BT50 -CT32SA -95CF	1	32	73	-	95	-	-	90	-	-	-	18	12,000	4.8	58,300	HS-3-32
3146 40532105	-105CF	1	32	73	-	105	-	-	90	-	-	-	18	12,000	5.1	58,300	
3146 40532120	-120CF	3	32	73	87	120	26	56	90	-	-	-	18	12,000	5.8	60,420	
3146 40532135	-135CF	3	32	73	88	135	41	56	90	-	-	-	18	12,000	6.4	60,420	
3146 40532150	-150CF	3	32	73	87	150	56	56	90	-	-	-	18	11,000	6.9	62,540	
3146 40532165	-165CF	3	32	73	86	165	71	56	90	-	-	-	18	10,000	7.4	62,540	
3146 40542095	-CT42SA -95CF	1	42	88	-	95	-	-	90	-	-	-	18	10,000	5.1	64,660	HS-4-42
3146 40542105	-105CF	1	42	88	-	105	-	-	90	-	-	-	18	10,000	5.6	64,660	
3146 40542120	-120CF	1	42	88	-	120	-	-	90	-	-	-	18	10,000	6.4	64,660	
3146 40542135	-135CF	1	42	88	-	135	-	-	90	-	-	-	18	10,000	7.0	66,780	
3146 40542150	-150CF	1	42	88	-	150	-	-	90	-	-	-	18	10,000	7.7	66,780	
3146 40542165	-165CF	1	42	88	-	165	-	-	90	-	-	-	18	9,000	8.4	68,900	

- Al hacer su orden, indique el número de llaves inglesas que requiere. Las llaves inglesas "son gratuitas" y están limitadas al número de portaherramientas de fresado de su orden.
- La tolerancia del zanco de las herramientas de corte debe estar dentro de h7.
- Complete con pernos de retención tipo BL.
- No se pueden usar accesorios a excepción de las boquillas MC-C y MC-OH.

- When ordering, indicate number of spanners required. "No charge" spanners are limited to number of milling chucks on order.
- Tolerance of cutting tool shank must be h7.
- Complete with stopper bolt type BL.
- Accessories cannot be used except for MC-C and MC-OH.

Longitud Mínima de inserción Min. chucking length

Sin boquilla MC
Without MC collet

D.I. del portaherramienta de fresado I.D. of Milling Chuck	Longitud mín de inserción Min. chucking length
16, 20	40
25, 32, 42	50

Con boquilla MC
With MC collet

D.I. de la boquilla Collet I.D.	Longitud mín de inserción Min. chucking length	
	MC	MC-C, MC-OH
6, 8	30	30
10, 12	40	40
16, 20	45	45
25	50	50
32	50	60

MC-OH, MC-C Collet

Pág. 070-071

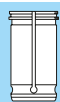

Llave Inglesa Spanner

Pág. 073



Ejemplo para Ordenar - Ordering Example

BT30 - CT 16 SA - 75 CF

Interfaz y
diámetro
de husillo

Diámetro
Interno

Longitud de
proyección

Shank size

I.D. (d)

Projection
length (L)

NT-CT-SA

Super Tite-Lock Milling Chuck

- Super Tite-Lock Milling Chuck delgado. Sus ranuras tienen un diseño especial para permitir desbastes pesados.
- Slim design milling chuck. Specially designed slits enable heavy endmilling.

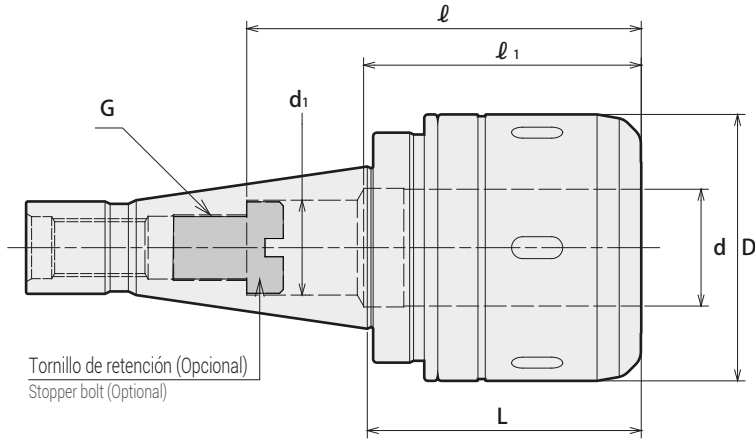

Precaución/ Caution

Favor de girar el anillo de sujeción en sentido contrario a las manecillas del reloj por más de 360 grados después de remover una herramienta de corte.

Please rotate the clamping ring counterclockwise more than 360 degrees after a cutting tool is removed.

Medidas Métricas - Metric Sizes

Unidad : Métrico

Unit : Metric

Código Code	Modelo Model	d	D	L	ℓ	ℓ	d1	G P=1.0	Perno de extracción Draw-bolt	Max. min ⁱ	Kg	-	Llave Inglesa Spanner
3140 41120070	NT30 -CT20SA -70 (U)	20	52	70	80	-	-	M12	U1/2-13	15,000	1.0	35,520	
3140 42120070	-70 (M)	20	52	70	80	-	-	M12	M12 P=1.75	15,000	1.0	35,520	HS-2-20
3140 43120070	-70 (W)	20	52	70	80	-	-	M12	W1/2-12	15,000	1.0	35,520	
3140 41320070	NT40 -CT20SA -70 (U)	20	52	70	80	-	-	M12	U5/8-11	18,000	1.5	37,060	
3140 42320070	-70 (M)	20	52	70	80	-	-	M12	M16 P=2	18,000	1.5	37,060	HS-2-20
3140 41332075	-CT32SA -75 (U) * 1	32	73	75	108	76	26	M18	U5/8-11	12,000	2.0	40,330	
3140 42332075	-75 (M) * 1	32	73	75	108	76	26	M18	M16 P=2	12,000	2.0	40,330	HS-3-32
3140 41532085	NT50 -CT32SA -85 (U)	32	73	85	120	-	-	M18	U1-8	12,000	4.0	49,820	
3140 42532085	-85 (M)	32	73	85	120	-	-	M18	M24 P=3	12,000	4.1	49,820	HS-3-32
3140 41542085	-CT42SA -85 (U)	42	88	85	120	-	-	M18	U1-8	10,000	4.5	56,180	
3140 42542085	-85 (M)	42	88	85	120	-	-	M18	M24 P=3	10,000	4.5	56,180	HS-4-42

1. Al hacer su orden, indique el número de llaves inglesas que requiere. Las llaves inglesas "son gratuitas" y están limitadas al número de portaherramientas de fresado de su orden.

2. La tolerancia del zanco de las herramientas de corte debe estar dentro de h7.

1. When ordering, indicate number of spanners required. "No charge" spanners are limited to number of milling chucks on order.

2. Tolerance of cutting tool shank must be h7.

Ejemplo para Ordenar - Ordering Example

NT40 - CT 32 SA - 75 (U)

Interfaz y
diámetro de husillo

Diámetro
Interno

Longitud de
proyección

Perno de
tracción

Shank size

I.D. (d)

Projection
length (L)

Draw-bolt

Llave Inglesa
Spanner

Pág. 073



Accesorios Accessories

Los modelos con * 1 no pueden usarse con algunos accesorios debido a la corta ℓ longitud.
Models with * 1 cannot be used with some accessories due to short ℓ length.

	Tornillo de retención Stopper Bolt	Boquilla recta Straight Collet		Adaptador Morse Morse Taper Adapter		Adaptador Jacobs Jacobs Adapter	
	BL (Pág.072)	MC (Pág.070)	MCA (Pág.071)	MA (Pág.072)	MAB (Pág.072)	JA (Pág.073)	JAB (Pág.073)
* 1	Sí / Yes	Sí / Yes	Sí / Yes	No	Sí / Yes	No	Sí / Yes

Longitud Mínima de inserción Min. chucking length

Sin boquilla MC
Without MC collet

D.I. del portaherramienta de fresado I.D. of Milling Chuck	Longitud mín de inserción Min. chucking length
20	40
25, 32, 42	50

Con boquilla MC
With MC collet

D.I. de la boquilla Collet I.D.	Longitud mín de inserción Min. chucking length	
	MC	MC-C, MC-OH
6, 8	30	30
10, 12	40	40
16, 20	45	45
25	50	50
32	50	60

Pulgada a métrico → Pulgada × 25.4

Métrico a pulgada → Métrico ÷ 25.4 ó métrico por 0.03937



Tamaños especiales / personalizados bajo pedido

NOTAS

Accesorios para Milling Chuck - Milling Chuck Accessories

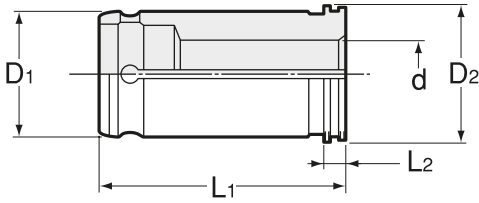

Medida en Pulgadas Inch Sizes		Unidad : Pulgadas Unit : Inch		
Tipo Type	D ₁	D ₂	L ₁	L ₂
MC 0750	0.750	0.945	2.362	0.157
1000	1.000	1.142	2.362	0.157
1250	1.250	1.417	2.835	0.157
2000	2.000	2.244	3.346	0.157

Medidas Métricas Metric Sizes		Unidad : Métrico Unit : Metric		
Tipo Type	D ₁	D ₂	L ₁	L ₂
MC 16	16	19	50	4
20	20	24	60	4
25	25	29	60	4
32	32	36	72	4
42	42	47	85	4

Boquilla estándar MC - Standard Collet MC

d Capacidad de la boquilla - Collet capacity d	Boquilla fuera del diámetro D ₁ - Collet outside diameter D ₁								
	0.750	1.000	1.250	2.000	16mm	20mm	25mm	32mm	42mm
1/4	MC0750-0250	MC1000-0250	MC1250-0250						
5/16	MC0750-0312	MC1000-0312	MC1250-0312						
3/8	MC0750-0375	MC1000-0375	MC1250-0375						
1/2	MC0750-0500	MC1000-0500	MC1250-0500						
5/8	MC0750-0625	MC1000-0625	MC1250-0625						
3/4		MC1000-0750	MC1250-0750						
7/8		MC1000-0875	MC1250-0875						
1			MC1250-1000	MC2000-1000					
1-1/4				MC2000-1250					
1-1/2				MC2000-1500					
6mm	MC0750-6	MC1000-6	MC1250-6		MC16-6	MC20-6	MC25-6	MC32-6	MC42-6
8mm	MC0750-8	MC1000-8	MC1250-8		MC16-8	MC20-8	MC25-8	MC32-8	MC42-8
10mm	MC0750-10	MC1000-10	MC1250-10		MC16-10	MC20-10	MC25-10	MC32-10	MC42-10
12mm	MC0750-12	MC1000-12	MC1250-12		MC16-12	MC20-12	MC25-12	MC32-12	MC42-12
16mm	MC0750-16	MC1000-16	MC1250-16			MC20-16	MC25-16	MC32-16	MC42-16
20mm		MC1000-20	MC1250-20				MC25-20	MC32-20	MC42-20
25mm			MC1250-25					MC32-25	MC42-25
32mm									MC42-32

1.No aplica en algunas medidas de portaherramienta. Favor de consultar las páginas sobre el portaherramienta de fresado.
1.Not applicable for some holder sizes. Please see milling chuck pages.

Ejemplo para Ordenar - Ordering Example

MC 42 - 32
Medida Size (D₁) Diámetro d

Boquilla refrigerante MC-OH (para cortadores con vena de lubricación)

Coolant Collet MC-OH (for cutters with coolant hole)

d Capacidad de la boquilla - Collet capacity d	Boquilla fuera de diámetro D ₁ - Collet outside diameter D ₁								
	0.750	1.000	1.250	2.000	16mm	20mm	25mm	32mm	42mm
1/4	MC0750-0250-OH	MC1000-0250-OH	MC1250-0250-OH		MC16-0250-OH	MC20-0250-OH	MC25-0250-OH	MC32-0250-OH	MC42-0250-OH
5/16	MC0750-0312-OH	MC1000-0312-OH	MC1250-0312-OH		MC16-0312-OH	MC20-0312-OH	MC25-0312-OH	MC32-0312-OH	MC42-0312-OH
3/8	MC0750-0375-OH	MC1000-0375-OH	MC1250-0375-OH		MC16-0375-OH	MC20-0375-OH	MC25-0375-OH	MC32-0375-OH	MC42-0375-OH
1/2	MC0750-0500-OH	MC1000-0500-OH	MC1250-0500-OH		MC16-0500-OH	MC20-0500-OH	MC25-0500-OH	MC32-0500-OH	MC42-0500-OH
5/8	MC0750-0625-OH	MC1000-0625-OH	MC1250-0625-OH			MC20-0625-OH	MC25-0625-OH	MC32-0625-OH	MC42-0625-OH
3/4		MC1000-0750-OH	MC1250-0750-OH				MC25-0750-OH	MC32-0750-OH	MC42-0750-OH
7/8		MC1000-0875-OH	MC1250-0875-OH				MC25-0875-OH	MC32-0875-OH	MC42-0875-OH
1			MC1250-1000-OH	MC2000-1000-OH				MC32-1000-OH	MC42-1000-OH
1-1/4				MC2000-1250-OH					MC42-1250-OH
1-1/2				MC2000-1500-OH					MC42-1500-OH
6mm	MC0750-6-OH	MC1000-6-OH	MC1250-6-OH		MC16-6-OH	MC20-6-OH	MC25-6-OH	MC32-6-OH	MC42-6-OH
8mm	MC0750-8-OH	MC1000-8-OH	MC1250-8-OH		MC16-8-OH	MC20-8-OH	MC25-8-OH	MC32-8-OH	MC42-8-OH
10mm	MC0750-10-OH	MC1000-10-OH	MC1250-10-OH		MC16-10-OH	MC20-10-OH	MC25-10-OH	MC32-10-OH	MC42-10-OH
12mm	MC0750-12-OH	MC1000-12-OH	MC1250-12-OH		MC16-12-OH	MC20-12-OH	MC25-12-OH	MC32-12-OH	MC42-12-OH
16mm	MC0750-16-OH	MC1000-16-OH	MC1250-16-OH			MC20-16-OH	MC25-16-OH	MC32-16-OH	MC42-16-OH
20mm		MC1000-20-OH	MC1250-20-OH				MC25-20-OH	MC32-20-OH	MC42-20-OH
25mm			MC1250-25-OH					MC32-25-OH	MC42-25-OH
32mm									MC42-32-OH

1.No aplica en algunas medidas de portaherramienta. Favor de consultar las páginas sobre el portaherramienta de fresado.
1.Not applicable for some holder sizes. Please see milling chuck pages.

Ejemplo para Ordenar - Ordering Example

MC 42 - 32 - OH
Medida Size (D₁) Diámetro d

Boquilla refrigerante MC-C (para cortadores sin vena de lubricación)

Coolant Collet MC-C (for cutters without coolant hole)

d Capacidad de la boquilla - Collet capacity d	Boquilla fuera de diámetro D ₁ - Collet outside diameter D ₁								
	0.750	1.000	1.250	2.000	16mm	20mm	25mm	32mm	42mm
1/4	MC0750-0250-C	MC1000-0250-C	MC1250-0250-C		MC16-0250-C	MC20-0250-C	MC25-0250-C	MC32-0250-C	MC42-0250-C
5/16	MC0750-0312-C	MC1000-0312-C	MC1250-0312-C		MC16-0312-C	MC20-0312-C	MC25-0312-C	MC32-0312-C	MC42-0312-C
3/8	MC0750-0375-C	MC1000-0375-C	MC1250-0375-C		MC16-0375-C	MC20-0375-C	MC25-0375-C	MC32-0375-C	MC42-0375-C
1/2	MC0750-0500-C	MC1000-0500-C	MC1250-0500-C		MC16-0500-C	MC20-0500-C	MC25-0500-C	MC32-0500-C	MC42-0500-C
5/8	MC0750-0625-C	MC1000-0625-C	MC1250-0625-C			MC20-0625-C	MC25-0625-C	MC32-0625-C	MC42-0625-C
3/4		MC1000-0750-C	MC1250-0750-C				MC25-0750-C	MC32-0750-C	MC42-0750-C
7/8		MC1000-0875-C	MC1250-0875-C				MC25-0875-C	MC32-0875-C	MC42-0875-C
1			MC1250-1000-C	MC2000-1000-C				MC32-1000-C	MC42-1000-C
1-1/4				MC2000-1250-C					MC42-1250-C
1-1/2				MC2000-1500-C					MC42-1500-C
6mm	MC0750-6-C	MC1000-6-C	MC1250-6-C		MC16-6-C	MC20-6-C	MC25-6-C	MC32-6-C	MC42-6-C
8mm	MC0750-8-C	MC1000-8-C	MC1250-8-C		MC16-8-C	MC20-8-C	MC25-8-C	MC32-8-C	MC42-8-C
10mm	MC0750-10-C	MC1000-10-C	MC1250-10-C		MC16-10-C	MC20-10-C	MC25-10-C	MC32-10-C	MC42-10-C
12mm	MC0750-12-C	MC1000-12-C	MC1250-12-C		MC16-12-C	MC20-12-C	MC25-12-C	MC32-12-C	MC42-12-C
16mm	MC0750-16-C	MC1000-16-C	MC1250-16-C			MC20-16-C	MC25-16-C	MC32-16-C	MC42-16-C
20mm		MC1000-20-C	MC1250-20-C				MC25-20-C	MC32-20-C	MC42-20-C
25mm			MC1250-25-C					MC32-25-C	MC42-25-C
32mm									MC42-32-C

1.No aplica en algunas medidas de portaherramienta. Favor de consultar las páginas sobre el portaherramienta de fresado.

1.Not applicable for some holder sizes. Please see milling chuck pages.

Ejemplo para Ordenar - Ordering Example

MC 42 - 32 - C
 Medida Size (D₁) Diámetro d

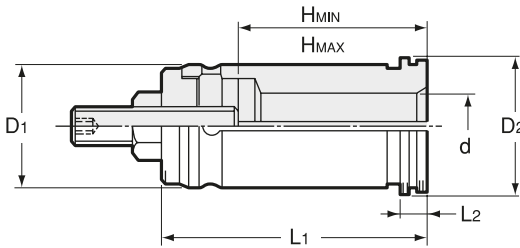

Medida en Pulgadas Inch Sizes		Unidad : Pulgadas Unit : Inch				
Tipo - Type	D ₁	D ₂	L ₁	L ₂	H _{MAX}	
MCA 0750	0.750	0.945	2.559	0.157	2.165	
1000	1.000	1.142	2.559	0.157	2.165	
1250	1.250	1.417	3.110	0.157	2.598	
2000	2.000	2.244	3.622	0.157	3.110	

Medidas Métricas Metric Sizes		Unidad : Métrico Unit : Metric				
Tipo Type	D ₁	D ₂	L ₁	L ₂	H _{MAX}	
MCA 16	16	19	55	4	45	
20	20	24	65	4	55	
25	25	29	65	4	55	
32	32	36	79	4	66	
42	42	47	92	4	79	

Boquilla recta MCA (con tornillo de ajuste de profundidad)

Straight Collet MCA (with depth adjustment stop screw)

d Capacidad de la boquilla - Collet capacity d	Boquilla fuera de diámetro D ₁ - Collet outside diameter D ₁								
	0.750	1.000	1.250	2.000	16mm	20mm	25mm	32mm	42mm
1/4	MCA0750-0250	MCA1000-0250	MCA1250-0250						
5/16	MCA0750-0312	MCA1000-0312	MCA1250-0312						
3/8	MCA0750-0375	MCA1000-0375	MCA1250-0375						
1/2	MCA0750-0500	MCA1000-0500	MCA1250-0500						
5/8		MCA1000-0625	MCA1250-0625						
3/4		MCA1000-0750	MCA1250-0750						
7/8			MCA1250-0875						
1				MCA2000-1000					
1-1/4				MCA2000-1250					
1-1/2				MCA2000-1500					
6mm	MCA0750-6	MCA1000-6	MCA1250-6		MCA16-6	MCA20-6	MCA25-6	MCA32-6	MCA42-6
8mm	MCA0750-8	MCA1000-8	MCA1250-8		MCA16-8	MCA20-8	MCA25-8	MCA32-8	MCA42-8
10mm	MCA0750-10	MCA1000-10	MCA1250-10		MCA16-10	MCA20-10	MCA25-10	MCA32-10	MCA42-10
12mm	MCA0750-12	MCA1000-12	MCA1250-12		MCA16-12	MCA20-12	MCA25-12	MCA32-12	MCA42-12
16mm		MCA1000-16	MCA1250-16			MCA20-16	MCA25-16	MCA32-16	MCA42-16
20mm		MCA1000-20	MCA1250-20				MCA25-20	MCA32-20	MCA42-20
25mm			MCA1250-25					MCA32-25	MCA42-25
32mm									MCA42-32

1.No aplica en algunas medidas de portaherramienta. Favor de consultar las páginas sobre el portaherramienta de fresado.

1.Not applicable for some holder sizes. Please see milling chuck pages.

Ejemplo para Ordenar - Ordering Example

MCA 42 - 32
 Medida Size (D₁) Diámetro d

Accesorios para Milling Chuck - Milling Chuck Accessories

Tornillo de retención BL - Stopper Bolt BL

Medidas Métricas / Metric Sizes Unidad : Métrico / Unit : Metric

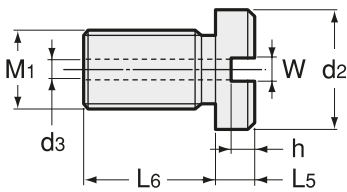

Código Code	Modelo Model	M1 P=1.0	L5	L6	W	h	d2	d3	Portaherramienta Chucks
0711 040016 ※※	BL 16 -L5	10	5, 15, 25	14	5	3.5	15	4.5	CT16
0711 040020 ※※	BL 20 -L5	12	5, 15, 25	14	5	3.5	18	4.5	CT20, CT25
0711 040032 ※※	BL 32 -L5	18	10, 20, 35	17	5	5	25	4.5	CT32, CT42

Ejemplo para Ordenar - Ordering Example

BL 16 - 15
Medida Size L5

Elija la dimensión L5 correcta; para esto, revise la longitud mínima de inserción y la profundidad del diámetro interno (D.I.) del zanco.

Choose right L5 dimension by checking minimum insertion length and shank I.D. depth.

Adaptador ahusado Morse (con tuerca ciega Tr.)

Morse Taper Adapter MA (with Tr. nut)

Medidas Métricas / Metric Sizes Unidad : Métrico / Unit : Metric

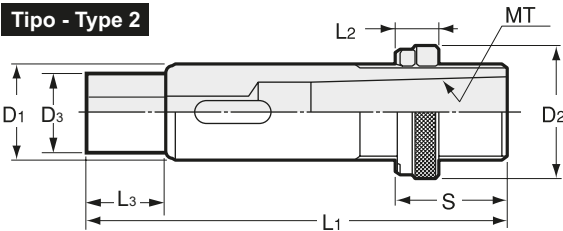
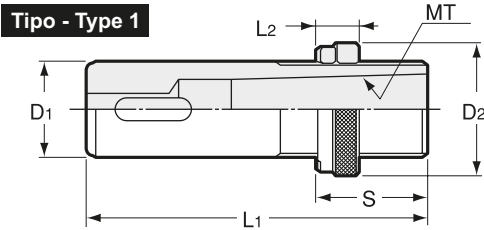

Código Code	Modelo Model	Type	D1	MT	D2	D3	L1	L2	L3	S
0714 02000161	MA 16 -MT1	1	16	1	24.6	—	76	16	—	16 ~ 32
0714 02000201	20 -MT1	1	20	1	31.6	—	85	16	—	16 ~ 37
0714 02000251	25 -MT1	1	25	1	35.6	—	89	16	—	16 ~ 37
0714 02000252	-MT2	1	25	2	35.6	—	89	16	—	16 ~ 37
0714 02000321	32 -MT1	2	32	1	44.6	25	119	19	30	19 ~ 39
0714 02000322	-MT2	2	32	2	44.6	25	119	19	30	19 ~ 39
0714 02000323	-MT3	2	32	3	44.6	25	119	19	30	19 ~ 39
0714 02000421	42 -MT1	1	42	1	55.6	—	135	19	—	19 ~ 48
0714 02000422	-MT2	1	42	2	55.6	—	135	19	—	19 ~ 48
0714 02000423	-MT3	1	42	3	55.6	—	135	19	—	19 ~ 48
0714 02000424	-MT4	1	42	4	55.6	—	135	19	—	19 ~ 48

No aplica en algunas medidas de portaherramienta. Favor de consultar las páginas sobre el portaherramienta de fresado.

Not applicable for some holder sizes. Please see milling chuck pages.

Ejemplo para Ordenar - Ordering Example

MA 16 - MT1
Medida Size MT No. MT No.

Adaptador Morse MAB

Morse Taper Adapter MAB

Medidas Métricas / Metric Sizes Unidad : Métrico / Unit : Metric

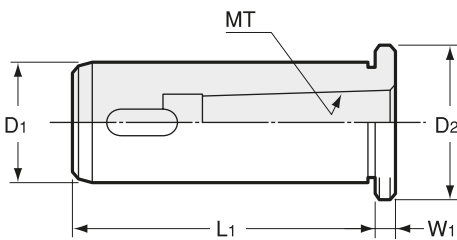

Código Code	Modelo Model	D1	MT	L1	D2	W1
0711 02100161	MAB 16 -MT1	16	1	60	19	15
0711 02100201	20 -MT1	20	1	75	24	5
0711 02100251	25 -MT1	25	1	75	29	5
0711 02100252	-MT2	25	2	75	29	20
0711 02100321	32 -MT1	32	1	75	36	5
0711 02100322	-MT2	32	2	75	36	20
0711 02100323	-MT3	32	3	75	36	35
0711 02100421	42 -MT1	42	1	115	47	5
0711 02100422	-MT2	42	2	115	47	5
0711 02100423	-MT3	42	3	115	47	5
0711 02100424	-MT4	42	4	115	47	20

No aplica en algunas medidas de portaherramienta. Favor de consultar las páginas sobre el portaherramienta de fresado.

Not applicable for some holder sizes. Please see milling chuck pages.

Adaptador Jacobs JA (con tuerca ciega Tr.)

Jacobs Adapter JA (with Tr. nut)

Medidas Métricas Unidad : Métrico
Metric Sizes Unit : Metric

Tipo - Type 1

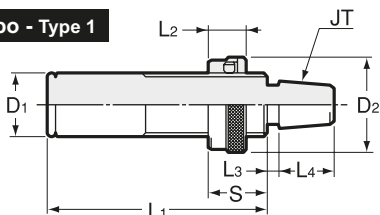

Tipo - Type 2

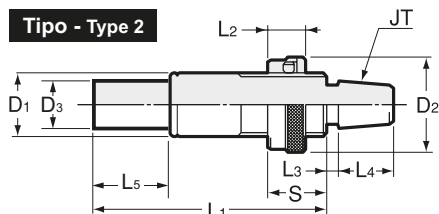

Código Code	Modelo Model	Tipo Type	D1	JT	D2	D3	L1	L2	S	L3	L4	L5
0714 03000162	JA 16 -JT2S	1	16	2S	24.6	—	76	16	16 ~ 32	3	18	—
0714 03000202	20 -JT2S	1	20	2S	31.6	—	85	16	16 ~ 37	3	18	—
0714 03000206	-JT6	1	20	6	31.6	—	85	16	16 ~ 37	4	24	—
0714 03000252	25 -JT2S	1	25	2S	35.6	—	85	16	16 ~ 37	3	18	—
0714 03000256	-JT6	1	25	6	35.6	—	85	16	16 ~ 37	4	24	—
0714 03000322	32 -JT2S	2	32	2S	44.6	25	119	19	19 ~ 39	3	18	30
0714 03000326	-JT6	2	32	6	44.6	25	119	19	19 ~ 39	4	24	30
0714 03000422	42 -JT2S	1	42	2S	55.6	—	135	19	19 ~ 48	3	18	—
0714 03000426	-JT6	1	42	6	55.6	—	135	19	19 ~ 48	4	24	—

No aplica en algunas medidas de portaherramienta. Favor de consultar las páginas sobre el portaherramienta de fresado.

Not applicable for some holder sizes. Please see milling chuck pages.

Ejemplo para Ordenar - Ordering Example

JA 16 - JT2S
Medida Size JT No. JT No.

Adaptador Jacobs JAB

Jacobs Adapter JAB

Medidas Métricas Unidad : Métrico
Metric Sizes Unit : Metric

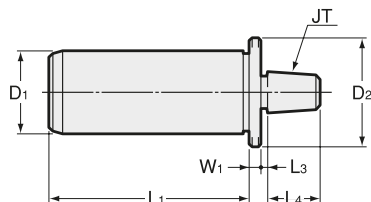

Código Code	Modelo Model	D1	JT	L1	D2	W1	L3	L4
0711 03100162	JAB 16 -JT2S	16	2S	60	19	3	3	18
0711 03100202	20 -JT2S	20	2S	75	24	3	3	18
0711 03100206	-JT6	20	6	75	24	3	4	24
0711 03100252	25 -JT2S	25	2S	75	29	3	3	18
0711 03100256	-JT6	25	6	75	29	3	4	24
0711 03100322	32 -JT2S	32	2S	75	36	3	3	18
0711 03100326	-JT6	32	6	75	36	3	4	24
0711 03100422	42 -JT2S	42	2S	115	47	3	3	18
0711 03100426	-JT6	42	6	115	47	3	4	24

No aplica en algunas medidas de portaherramienta. Favor de consultar las páginas sobre el portaherramienta de fresado.

Not applicable for some holder sizes. Please see milling chuck pages.

Ejemplo para Ordenar - Ordering Example

JAB 16 - JT2S
Medida Size JT No. JT No.

Llave Inglesa - Spanner



Ejemplo para Ordenar - Ordering Example

HS - 1 - 16

Código Code	Llave Inglesa Spanner	Portaherramienta Chucks	Medida del Portaherramienta Chuck size	
			mm	Inch
0711 00001016	HS-1-16	CT·S, CT·A	16	—
0711 00002020	HS-2-20	CT·S, CT·A	20	0750
0711 00002525	HS-2.5-25	CT·S, CT·A, CTZ	25	1000
0711 00003032	HS-3-32	CT·S, CT·A, CTZ	32	1250
0711 00004042	HS-4-42	CT·S, CT·A, CTZ	42	—
0711 00005042	HS-4V	CT·S	—	2000

High-Precision Collet Holder

- Adecuado para barrenado, rimado y acabado en fresa.
- Suitable for drilling, reaming and finish endmilling.

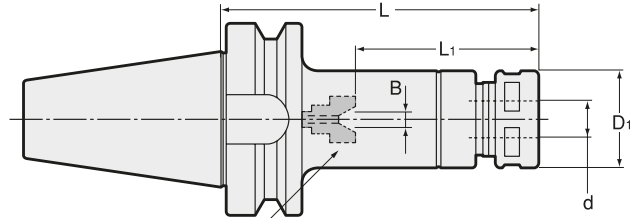

Tornillo de preajuste (incluido)
Preset Screw (Included)

Unidad : Métrico
Unit : Metric

	Código Code	Modelo Model	d	L	B	L1	D1	Tuerca ciega Nut	kg	Boquilla Collet	Llave Inglesa Spanner
Milling Chuck	2540 10107045	BT30 -HDC07A -45	0.5 ~ 7.0	45	0 ~ 4	22 ~ 43	23	HDP-07A	0.5	FDC-07	S-0
	2540 10107060	-60	0.5 ~ 7.0	60	0 ~ 4	22 ~ 45	23	HDP-07A	0.5		
Collet Holder	2540 10107075	-75	0.5 ~ 7.0	75	0 ~ 4	22 ~ 45	23	HDP-07A	0.5		
	2540 10107090	-90	0.5 ~ 7.0	90	0 ~ 4	22 ~ 45	23	HDP-07A	0.6		
"R" Zero Holder	2540 10107105	-105	0.5 ~ 7.0	105	0 ~ 4	22 ~ 45	23	HDP-07A	0.6		
	2540 10107120	-120	0.5 ~ 7.0	120	0 ~ 4	22 ~ 45	23	HDP-07A	0.7		
Hydraulic Chuck	2540 10107135	-135	0.5 ~ 7.0	135	0 ~ 4	22 ~ 45	23	HDP-07A	0.7		
	2540 10109045	BT30 -HDC09A -45	2.5 ~ 9.0	45	0 ~ 4	27 ~ 44	26	HDP-09	0.5		
Shrink Fit	2540 10109060	-60	2.5 ~ 9.0	60	0 ~ 4	27 ~ 54	26	HDP-09	0.5		
	2540 10109075	-75	2.5 ~ 9.0	75	0 ~ 4	27 ~ 57	26	HDP-09	0.6		
Tapping Chuck	2540 10109090	-90	2.5 ~ 9.0	90	0 ~ 4	27 ~ 57	26	HDP-09	0.6		
	2540 10109105	-105	2.5 ~ 9.0	105	0 ~ 4	27 ~ 57	26	HDP-09	0.7		
Arbors	2540 10109120	-120	2.5 ~ 9.0	120	0 ~ 4	27 ~ 57	26	HDP-09	0.7		
	2540 10109135	-135	2.5 ~ 9.0	135	0 ~ 4	27 ~ 57	26	HDP-09	0.8		
Function Holder	2540 10112045	BT30 -HDC12A -45	2.5 ~ 12.0	45	0 ~ 5	33 ~ 51	32	HDP-12	0.5		
	2540 10112060	-60	2.5 ~ 12.0	60	0 ~ 5	33 ~ 54	32	HDP-12	0.6		
Turning Tool	2540 10112075	-75	2.5 ~ 12.0	75	0 ~ 5	33 ~ 69	32	HDP-12	0.6		
	2540 10112090	-90	2.5 ~ 12.0	90	0 ~ 5	33 ~ 69	32	HDP-12	0.7		
Retention Stud	2540 10112105	-105	2.5 ~ 12.0	105	0 ~ 5	33 ~ 69	32	HDP-12	0.8		
	2540 10112120	-120	2.5 ~ 12.0	120	0 ~ 5	33 ~ 69	32	HDP-12	0.9		
Tool Shank Dimensions	2540 10112135	-135	2.5 ~ 12.0	135	0 ~ 5	33 ~ 69	32	HDP-12	1.0		
	2540 10116045	BT30 -HDC16A -45	3.5 ~ 16.0	45	0 ~ 6	38 ~ 51	36	HDP-16	0.4		
Retention Stud	2540 10116060	-60	3.5 ~ 16.0	60	0 ~ 6	38 ~ 54	36	HDP-16	0.6		
	2540 10116075	-75	3.5 ~ 16.0	75	0 ~ 6	38 ~ 69	36	HDP-16	0.6		
Turning Tool	2540 10116090	-90	3.5 ~ 16.0	90	0 ~ 6	38 ~ 82	36	HDP-16	0.7		
	2540 10116105	-105	3.5 ~ 16.0	105	0 ~ 6	38 ~ 82	36	HDP-16	0.9		
Function Holder	2540 10116120	-120	3.5 ~ 16.0	120	0 ~ 6	38 ~ 82	36	HDP-16	1.0		
	2540 10116135	-135	3.5 ~ 16.0	135	0 ~ 6	38 ~ 82	36	HDP-16	1.1		
Retention Stud	2540 10122045	BT30 -HDC22A -45	3.5 ~ 22.0	45	—	52	46	HDP-22	0.4		
	2540 10122060	-60	3.5 ~ 22.0	60	0 ~ 8	47 ~ 49	46	HDP-22	0.6		
Turning Tool	2540 10122075	-75	3.5 ~ 22.0	75	0 ~ 8	47 ~ 64	46	HDP-22	0.7		
	2540 10122090	-90	3.5 ~ 22.0	90	0 ~ 8	47 ~ 79	46	HDP-22	0.9		
Retention Stud	2540 10122105	-105	3.5 ~ 22.0	105	0 ~ 8	47 ~ 94	46	HDP-22	1.0		
	2540 10122120	-120	3.5 ~ 22.0	120	0 ~ 8	47 ~ 103	46	HDP-22	1.2		
Turning Tool	2540 10122135	-135	3.5 ~ 22.0	135	0 ~ 8	47 ~ 103	46	HDP-22	1.3		
	2540 10307060	BT40 -HDC07A -60	0.5 ~ 7.0	60	0 ~ 4	22 ~ 45	23	HDP-07A	1.1		
Retention Stud	2540 10307075	-75	0.5 ~ 7.0	75	0 ~ 4	22 ~ 45	23	HDP-07A	1.1		
	2540 10307090	-90	0.5 ~ 7.0	90	0 ~ 4	22 ~ 45	23	HDP-07A	1.1		
Turning Tool	2540 10307105	-105	0.5 ~ 7.0	105	0 ~ 4	22 ~ 45	23	HDP-07A	1.2		
	2540 10307120	-120	0.5 ~ 7.0	120	0 ~ 4	22 ~ 45	23	HDP-07A	1.3		
Retention Stud	2540 10309060	BT40 -HDC09A -60	2.5 ~ 9.0	60	0 ~ 4	27 ~ 57	26	HDP-09	1.1		
	2540 10309090	-90	2.5 ~ 9.0	90	0 ~ 4	27 ~ 57	26	HDP-09	1.2		
Turning Tool	2540 10309105	-105	2.5 ~ 9.0	105	0 ~ 4	27 ~ 57	26	HDP-09	1.2		
	2540 10309120	-120	2.5 ~ 9.0	120	0 ~ 4	27 ~ 57	26	HDP-09	1.3		
Retention Stud	2540 10309135	-135	2.5 ~ 9.0	135	0 ~ 4	27 ~ 57	26	HDP-09	1.3		
	2540 10309165	-165	2.5 ~ 9.0	165	0 ~ 4	27 ~ 57	26	HDP-09	1.4		

Código Code	Modelo Model	d	L	B	L1	D1	Tuerca ciega Nut	kg	Boquilla Collet	Llave Inglesa Spanner
2540 10312060	BT40 -HDC12A -60	2.5 ~ 12.0	60	0 ~ 5	33 ~ 61	32	HDP-12	1.2	FDC-12	S-3L
2540 10312090	-90	2.5 ~ 12.0	90	0 ~ 5	33 ~ 69	32	HDP-12	1.3		
2540 10312105	-105	2.5 ~ 12.0	105	0 ~ 5	33 ~ 69	32	HDP-12	1.3		
2540 10312120	-120	2.5 ~ 12.0	120	0 ~ 5	33 ~ 69	32	HDP-12	1.4		
2540 10312135	-135	2.5 ~ 12.0	135	0 ~ 5	33 ~ 69	32	HDP-12	1.5		
2540 10312165	-165	2.5 ~ 12.0	165	0 ~ 5	33 ~ 69	32	HDP-12	1.6		
2540 10312195	-195	2.5 ~ 12.0	195	0 ~ 5	33 ~ 69	32	HDP-12	1.8		
2540 10316060	BT40 -HDC16A -60	3.5 ~ 16.0	60	0 ~ 6	38 ~ 64	36	HDP-16	1.1	FDC-16	S-4L
2540 10316090	-90	3.5 ~ 16.0	90	0 ~ 6	38 ~ 82	36	HDP-16	1.3		
2540 10316105	-105	3.5 ~ 16.0	105	0 ~ 6	38 ~ 82	36	HDP-16	1.4		
2540 10316120	-120	3.5 ~ 16.0	120	0 ~ 6	38 ~ 82	36	HDP-16	1.5		
2540 10316135	-135	3.5 ~ 16.0	135	0 ~ 6	38 ~ 82	36	HDP-16	1.6		
2540 10316165	-165	3.5 ~ 16.0	165	0 ~ 6	38 ~ 82	36	HDP-16	1.8		
2540 10316195	-195	3.5 ~ 16.0	195	0 ~ 6	38 ~ 82	36	HDP-16	2.0		
2540 10322060	BT40 -HDC22A -60	3.5 ~ 22.0	60	0 ~ 8	47 ~ 66	46	HDP-22	1.1	FDC-22	S-5L
2540 10322075	-75	3.5 ~ 22.0	75	0 ~ 8	47 ~ 81	46	HDP-22	1.2		
2540 10322090	-90	3.5 ~ 22.0	90	0 ~ 8	47 ~ 96	46	HDP-22	1.4		
2540 10322105	-105	3.5 ~ 22.0	105	0 ~ 8	47 ~ 103	46	HDP-22	1.5		
2540 10322120	-120	3.5 ~ 22.0	120	0 ~ 8	47 ~ 103	46	HDP-22	1.7		
2540 10322135	-135	3.5 ~ 22.0	135	0 ~ 8	47 ~ 103	46	HDP-22	1.9		
2540 10322165	-165	3.5 ~ 22.0	165	0 ~ 8	47 ~ 103	46	HDP-22	2.2		
2540 10322195	-195	3.5 ~ 22.0	195	0 ~ 8	47 ~ 103	46	HDP-22	2.6		
2540 10507090	BT50 -HDC07A -90	0.5 ~ 7.0	90	0 ~ 4	22 ~ 45	23	HDP-07A	3.6	FDC-07	S-0
2540 10507105	-105	0.5 ~ 7.0	105	0 ~ 4	22 ~ 45	23	HDP-07A	3.6		
2540 10507120	-120	0.5 ~ 7.0	120	0 ~ 4	22 ~ 45	23	HDP-07A	3.7		
2540 10507135	-135	0.5 ~ 7.0	135	0 ~ 4	22 ~ 45	23	HDP-07A	3.7		
2540 10507165	-165	0.5 ~ 7.0	165	0 ~ 4	22 ~ 45	23	HDP-07A	3.9		
2540 10507195	-195	0.5 ~ 7.0	195	0 ~ 4	22 ~ 45	23	HDP-07A	4.0		
2540 10509090	BT50 -HDC09A -90	2.5 ~ 9.0	90	0 ~ 4	27 ~ 57	26	HDP-09	3.7	FDC-09	S-1L
2540 10509105	-105	2.5 ~ 9.0	105	0 ~ 4	27 ~ 57	26	HDP-09	3.8		
2540 10509120	-120	2.5 ~ 9.0	120	0 ~ 4	27 ~ 57	26	HDP-09	3.8		
2540 10509135	-135	2.5 ~ 9.0	135	0 ~ 4	27 ~ 57	26	HDP-09	3.8		
2540 10509165	-165	2.5 ~ 9.0	165	0 ~ 4	27 ~ 57	26	HDP-09	3.9		
2540 10509195	-195	2.5 ~ 9.0	195	0 ~ 4	27 ~ 57	26	HDP-09	4.0		
2540 10509225	-225	2.5 ~ 9.0	225	0 ~ 4	27 ~ 57	26	HDP-09	4.1		
2540 10509255	-255	2.5 ~ 9.0	255	0 ~ 4	27 ~ 57	26	HDP-09	4.3		
2540 10512090	BT50 -HDC12A -90	2.5 ~ 12.0	90	0 ~ 5	33 ~ 69	32	HDP-12	3.8	FDC-12	S-3L
2540 10512105	-105	2.5 ~ 12.0	105	0 ~ 5	33 ~ 69	32	HDP-12	3.8		
2540 10512120	-120	2.5 ~ 12.0	120	0 ~ 5	33 ~ 69	32	HDP-12	3.9		
2540 10512135	-135	2.5 ~ 12.0	135	0 ~ 5	33 ~ 69	32	HDP-12	4.0		
2540 10512165	-165	2.5 ~ 12.0	165	0 ~ 5	33 ~ 69	32	HDP-12	4.1		
2540 10512195	-195	2.5 ~ 12.0	195	0 ~ 5	33 ~ 69	32	HDP-12	4.3		
2540 10512225	-225	2.5 ~ 12.0	225	0 ~ 5	33 ~ 69	32	HDP-12	4.4		
2540 10512255	-255	2.5 ~ 12.0	255	0 ~ 5	33 ~ 69	32	HDP-12	4.6		
2540 10516090	BT50 -HDC16A -90	3.5 ~ 16.0	90	0 ~ 6	38 ~ 82	36	HDP-16	3.8	FDC-16	S-4L
2540 10516105	-105	3.5 ~ 16.0	105	0 ~ 6	38 ~ 82	36	HDP-16	3.9		
2540 10516120	-120	3.5 ~ 16.0	120	0 ~ 6	38 ~ 82	36	HDP-16	4.0		
2540 10516135	-135	3.5 ~ 16.0	135	0 ~ 6	38 ~ 82	36	HDP-16	4.1		
2540 10516165	-165	3.5 ~ 16.0	165	0 ~ 6	38 ~ 82	36	HDP-16	4.2		
2540 10516195	-195	3.5 ~ 16.0	195	0 ~ 6	38 ~ 82	36	HDP-16	4.5		
2540 10516225	-225	3.5 ~ 16.0	225	0 ~ 6	38 ~ 82	36	HDP-16	4.6		
2540 10516255	-255	3.5 ~ 16.0	255	0 ~ 6	38 ~ 82	36	HDP-16	4.8		
2540 10522105	BT50 -HDC22A -105	3.5 ~ 22.0	105	0 ~ 8	47 ~ 103	46	HDP-22	4.0	FDC-22	S-5L
2540 10522120	-120	3.5 ~ 22.0	120	0 ~ 8	47 ~ 103	46	HDP-22	4.2		
2540 10522135	-135	3.5 ~ 22.0	135	0 ~ 8	47 ~ 103	46	HDP-22	4.3		
2540 10522150	-150	3.5 ~ 22.0	150	0 ~ 8	47 ~ 103	46	HDP-22	4.5		
2540 10522165	-165	3.5 ~ 22.0	165	0 ~ 8	47 ~ 103	46	HDP-22	4.7		
2540 10522195	-195	3.5 ~ 22.0	195	0 ~ 8	47 ~ 103	46	HDP-22	5.0		
2540 10522225	-225	3.5 ~ 22.0	225	0 ~ 8	47 ~ 103	46	HDP-22	5.3		
2540 10522255	-255	3.5 ~ 22.0	255	0 ~ 8	47 ~ 103	46	HDP-22	5.6		

1. La boquilla, llave inglesa, tornillo Allen opresor de preajuste y el Tornillo de preajuste para procesos semisecos se venden por separado. El tornillo estándar de preajuste está incluido.
2. Consulte la pág.088 para conocer la longitud mínima para insertar herramientas en caso de usar nuestras boquillas refrigerantes (OH, C o MS).
- 3.L1 indica la dimensión al usarlo con un Tornillo de preajuste.
4. Consulte la pág. 485 para conocer el Torque recomendado en nuestros productos.
- 1.Collet, spanner, hexagon head preset screw, preset screw for semi-dry processing are sold separately. Standard preset screw is included.
- 2.Refer to P.088 for minimum tool insertion length in case of using our coolant collets (OH,C or MS).
- 3.L1 indicates dimension when using with a preset screw.
- 4.See P.485 for standard Tightening Torque.

Boquilla Collet Pág. 090-093	Llave Inglesa Spanner Pág. 099	Tornillo de preajuste Preset screw Pág. 098
		

Ejemplo para Ordenar - Ordering Example

BT30 - HDC 16 A - 105

Interfaz y diámetro de husillo Máx. Diámetro Interno de boquilla Longitud de proyección

Shank size Max. collet I.D. Projection length (L)

HDC·A-CF

High-Precision Collet Holder (Flange Through Type)

- Con función de refrigeración a través del reborde del portaherramienta e interior de la boquilla. Conforme a DIN69871 Formulario B.
- Flange through coolant type collet holder. DIN69871 Form B compliance.

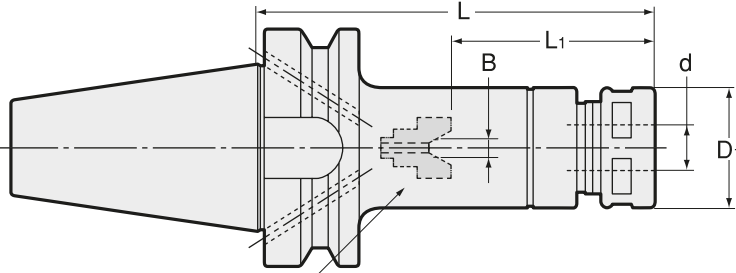

Tornillo de preajuste (incluido)
Preset Screw (Included)

- DIN69871 Formulario B
- Presión máxima del refrigerante
6MPa (HDC22A-CF)
7 MPa (Otros tamaños)

- DIN69871 Form B
- Max. Coolant pressure
6MPa (HDC22A-CF)
7MPa (Other sizes)

Unidad : Métrico
Unit : Metric

	Código Code	Modelo Model	d	L	B	L1	D1	Tuerca ciega Nut	kg	Boquilla Collet	Llave Inglesa Spanner
Milling Chuck	2546 10307075	BT40 -HDC07A -75CF	0.5 ~ 7.0	75	0 ~ 4	22 ~ 40	23	HDP-07A	1.1	FDC-07	S-0
	2546 10307090	-90CF	0.5 ~ 7.0	90	0 ~ 4	22 ~ 45	23	HDP-07A	1.1		
Collet Holder	2546 10307105	-105CF	0.5 ~ 7.0	105	0 ~ 4	22 ~ 45	23	HDP-07A	1.2	FDC-09	S-1L
	2546 10309090	BT40 -HDC09A -90CF	2.5 ~ 9.0	90	0 ~ 4	27 ~ 56	26	HDP-09	1.2		
"R" Zero Holder	2546 10309105	-105CF	2.5 ~ 9.0	105	0 ~ 4	27 ~ 57	26	HDP-09	1.3	FDC-12	S-3L
	2546 10309120	-120CF	2.5 ~ 9.0	120	0 ~ 4	27 ~ 57	26	HDP-09	1.3		
Hydraulic Chuck	2546 10309135	-135CF	2.5 ~ 9.0	135	0 ~ 4	27 ~ 57	26	HDP-09	1.4	FDC-16	S-4L
	2546 10309165	-165CF	2.5 ~ 9.0	165	0 ~ 4	27 ~ 57	26	HDP-09	1.5		
Shrink Fit	2546 10312090	BT40 -HDC12A -90CF	2.5 ~ 12.0	90	0 ~ 5	33 ~ 54	32	HDP-12	1.3	FDC-22	S-5L
	2546 10312105	-105CF	2.5 ~ 12.0	105	0 ~ 5	33 ~ 69	32	HDP-12	1.4		
Tapping Chuck	2546 10312120	-120CF	2.5 ~ 12.0	120	0 ~ 5	33 ~ 69	32	HDP-12	1.5	FDC-22	S-5L
	2546 10312135	-135CF	2.5 ~ 12.0	135	0 ~ 5	33 ~ 69	32	HDP-12	1.5		
Anchors	2546 10312165	-165CF	2.5 ~ 12.0	165	0 ~ 5	33 ~ 69	32	HDP-12	1.7	FDC-22	S-5L
	2546 10312195	-195CF	2.5 ~ 12.0	195	0 ~ 5	33 ~ 69	32	HDP-12	1.9		
Function Holder	2546 10316090	BT40 -HDC16A -90CF	3.5 ~ 16.0	90	0 ~ 6	38 ~ 56	36	HDP-16	1.3	FDC-22	S-5L
	2546 10316105	-105CF	3.5 ~ 16.0	105	0 ~ 6	38 ~ 71	36	HDP-16	1.4		
Turning Tool	2546 10316120	-120CF	3.5 ~ 16.0	120	0 ~ 6	38 ~ 82	36	HDP-16	1.5	FDC-22	S-5L
	2546 10316135	-135CF	3.5 ~ 16.0	135	0 ~ 6	38 ~ 82	36	HDP-16	1.7		
Retention Stud	2546 10316165	-165CF	3.5 ~ 16.0	165	0 ~ 6	38 ~ 82	36	HDP-16	1.8	FDC-22	S-5L
	2546 10316195	-195CF	3.5 ~ 16.0	195	0 ~ 6	38 ~ 82	36	HDP-16	2.0		
Tool Shank Dimensions	2546 10322105	BT40 -HDC22A -105CF	3.5 ~ 22.0	105	0 ~ 8	47 ~ 69	46	HDP-22	1.6	FDC-22	S-5L
	2546 10322120	-120CF	3.5 ~ 22.0	120	0 ~ 8	47 ~ 84	46	HDP-22	1.8		
Function Holder	2546 10322135	-135CF	3.5 ~ 22.0	135	0 ~ 8	47 ~ 99	46	HDP-22	1.9	FDC-22	S-5L
	2546 10322165	-165CF	3.5 ~ 22.0	165	0 ~ 8	47 ~ 103	46	HDP-22	2.3		
Turning Tool	2546 10322195	-195CF	3.5 ~ 22.0	195	0 ~ 8	47 ~ 103	46	HDP-22	2.6	FDC-22	S-5L
	2546 10507090	BT50 -HDC07A -90CF	0.5 ~ 7.0	90	0 ~ 4	22 ~ 45	23	HDP-07A	3.5		
Retention Stud	2546 10507105	-105CF	0.5 ~ 7.0	105	0 ~ 4	22 ~ 45	23	HDP-07A	3.6	FDC-07	S-0
	2546 10507120	-120CF	0.5 ~ 7.0	120	0 ~ 4	22 ~ 45	23	HDP-07A	3.7		
Tool Shank Dimensions	2546 10507135	-135CF	0.5 ~ 7.0	135	0 ~ 4	22 ~ 45	23	HDP-07A	3.8	FDC-09	S-1L
	2546 10507165	-165CF	0.5 ~ 7.0	165	0 ~ 4	22 ~ 45	23	HDP-07A	3.9		
Retention Stud	2546 10507195	-195CF	0.5 ~ 7.0	195	0 ~ 4	22 ~ 45	23	HDP-07A	4.0	FDC-09	S-1L
	2546 10509090	BT50 -HDC09A -90CF	2.5 ~ 9.0	90	0 ~ 4	27 ~ 48	26	HDP-09	3.6		
Turning Tool	2546 10509105	-105CF	2.5 ~ 9.0	105	0 ~ 4	27 ~ 57	26	HDP-09	3.7	FDC-09	S-1L
	2546 10509120	-120CF	2.5 ~ 9.0	120	0 ~ 4	27 ~ 57	26	HDP-09	3.8		
Retention Stud	2546 10509135	-135CF	2.5 ~ 9.0	135	0 ~ 4	27 ~ 57	26	HDP-09	3.9	FDC-09	S-1L
	2546 10509165	-165CF	2.5 ~ 9.0	165	0 ~ 4	27 ~ 57	26	HDP-09	4.0		
Tool Shank Dimensions	2546 10509195	-195CF	2.5 ~ 9.0	195	0 ~ 4	27 ~ 57	26	HDP-09	4.1	FDC-09	S-1L
	2546 10509225	-225CF	2.5 ~ 9.0	225	0 ~ 4	27 ~ 57	26	HDP-09	4.2		
Retention Stud	2546 10509255	-255CF	2.5 ~ 9.0	255	0 ~ 4	27 ~ 57	26	HDP-09	4.3	FDC-09	S-1L

Código Code	Modelo Model	d	L	B	L1	D1	Tuerca ciega Nut	kg	Boquilla Collet	Llave Inglesa Spanner
2546 10512090	BT50 -HDC12A -90CF	2.5 ~ 12.0	90	0 ~ 5	33 ~ 47	32	HDP-12	3.7	FDC-12	S-3L
2546 10512105	-105CF	2.5 ~ 12.0	105	0 ~ 5	33 ~ 62	32	HDP-12	3.8		
2546 10512120	-120CF	2.5 ~ 12.0	120	0 ~ 5	33 ~ 69	32	HDP-12	3.9		
2546 10512135	-135CF	2.5 ~ 12.0	135	0 ~ 5	33 ~ 69	32	HDP-12	4.0		
2546 10512165	-165CF	2.5 ~ 12.0	165	0 ~ 5	33 ~ 69	32	HDP-12	4.1		
2546 10512195	-195CF	2.5 ~ 12.0	195	0 ~ 5	33 ~ 69	32	HDP-12	4.2		
2546 10512225	-225CF	2.5 ~ 12.0	225	0 ~ 5	33 ~ 69	32	HDP-12	4.3		
2546 10512255	-255CF	2.5 ~ 12.0	255	0 ~ 5	33 ~ 69	32	HDP-12	4.4		
2546 10516090	BT50 -HDC16A -90CF	3.5 ~ 16.0	90	0 ~ 6	38 ~ 47	36	HDP-16	3.7		
2546 10516105	-105CF	3.5 ~ 16.0	105	0 ~ 6	38 ~ 62	36	HDP-16	3.8		
2546 10516120	-120CF	3.5 ~ 16.0	120	0 ~ 6	38 ~ 77	36	HDP-16	3.9		
2546 10516135	-135CF	3.5 ~ 16.0	135	0 ~ 6	38 ~ 82	36	HDP-16	4.0		
2546 10516165	-165CF	3.5 ~ 16.0	165	0 ~ 6	38 ~ 82	36	HDP-16	4.2		
2546 10516195	-195CF	3.5 ~ 16.0	195	0 ~ 6	38 ~ 82	36	HDP-16	4.4		
2546 10516225	-225CF	3.5 ~ 16.0	225	0 ~ 6	38 ~ 82	36	HDP-16	4.6		
2546 10516255	-255CF	3.5 ~ 16.0	255	0 ~ 6	38 ~ 82	36	HDP-16	4.8		
2546 10522105	BT50 -HDC22A -105CF	3.5 ~ 22.0	105	0 ~ 8	47 ~ 60	46	HDP-22	4.0	FDC-22	S-5L
2546 10522120	-120CF	3.5 ~ 22.0	120	0 ~ 8	47 ~ 75	46	HDP-22	4.2		
2546 10522135	-135CF	3.5 ~ 22.0	135	0 ~ 8	47 ~ 90	46	HDP-22	4.3		
2546 10522150	-150CF	3.5 ~ 22.0	150	0 ~ 8	47 ~ 103	46	HDP-22	4.4		
2546 10522165	-165CF	3.5 ~ 22.0	165	0 ~ 8	47 ~ 103	46	HDP-22	4.6		
2546 10522195	-195CF	3.5 ~ 22.0	195	0 ~ 8	47 ~ 103	46	HDP-22	4.8		
2546 10522225	-225CF	3.5 ~ 22.0	225	0 ~ 8	47 ~ 103	46	HDP-22	5.0		
2546 10522255	-255CF	3.5 ~ 22.0	255	0 ~ 8	47 ~ 103	46	HDP-22	5.2		

1. La boquilla, llave inglesa, tornillo Allen opresor de preajuste y el tornillo de preajuste para procesos semisecos se venden por separado. El tornillo estándar de preajuste está incluido.
2. Consulte la pág.088 para conocer la longitud mínima para insertar herramientas en caso de usar nuestras boquillas refrigerantes (OH, C o MS).
- 3.L1 indica la dimensión al usarlo con un tornillo de preajuste.
- 4.Consulte la pág. 485 para conocer el Torque recomendado en nuestros productos.

- 1.Collet, spanner, hexagon head preset screw and preset screw for semi-dry processing are sold separately. Standard preset screw is included.
- 2.Refer to P. 088 for minimum tool insertion length in case of using our coolant collets (OH,C or MS).
- 3.L1 indicates dimension when using with a preset screw.
4. See P.485 for standard Tightening Torque.

Boquilla Collet Pág. 090-093 	Llave Inglesa Spanner Pág. 099 	Tornillo de preajuste Preset screw Pág. 098 
---	---	--

Ejemplo para Ordenar - Ordering Example

BT30 - HDC 16 A - 105 CF

Interfaz y diámetro de husillo

Máx. Diámetro Interno de boquilla

Longitud de proyección

Shank size

Max. collet I.D.

Projection length (L)

Drill Holder With Easy Tool Length Adjustment

- La longitud de proyección de la herramienta de corte se puede ajustar simplemente al cuello del portaherramienta.
- Projection length of the cutting tool can be adjusted by simply turning circumference of the holder.

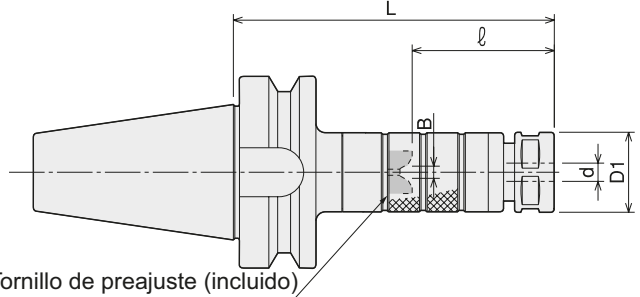

Tornillo de preajuste (incluido)
Preset Screw (Included)

Unidad : Métrico
Unit : Metric

	Código Code	Modelo Model	d	L	ℓ	B	D1	Tuerca ciega Nut	Boquilla Collet	Llave Inglesa Spanner
Milling Chuck	3920 00107075	BT30 -SDM07 -75	0.5 ~ 7.0	75	29 ~ 39	0 ~ 4	23	HDP-07A	FDC-07	S-0
	3920 00107090	-90	0.5 ~ 7.0	90	29 ~ 54	0 ~ 4	23	HDP-07A		
Collet Holder	3920 00107105	-105	0.5 ~ 7.0	105	29 ~ 54	0 ~ 4	23	HDP-07A	FDC-07	S-0
	3920 00107120	-120	0.5 ~ 7.0	120	29 ~ 54	0 ~ 4	23	HDP-07A		
	3920 00107135	-135	0.5 ~ 7.0	135	29 ~ 54	0 ~ 4	23	HDP-07A		
	3920 00107150	-150	0.5 ~ 7.0	150	29 ~ 54	0 ~ 4	23	HDP-07A		
"R" Zero Holder	3920 00109090	BT30 -SDM09 -90	2.5 ~ 9.0	90	28 ~ 38	0 ~ 4	26	HDP-09	FDC-09	S-1L
	3920 00109105	-105	2.5 ~ 9.0	105	28 ~ 53	0 ~ 4	26	HDP-09		
	3920 00109120	-120	2.5 ~ 9.0	120	28 ~ 53	0 ~ 4	26	HDP-09		
	3920 00109135	-135	2.5 ~ 9.0	135	28 ~ 53	0 ~ 4	26	HDP-09		
	3920 00109150	-150	2.5 ~ 9.0	150	28 ~ 53	0 ~ 4	26	HDP-09		
Hydraulic Chuck	3920 00109165	-165	2.5 ~ 9.0	165	28 ~ 53	0 ~ 4	26	HDP-09	FDC-12	S-3L
	3920 00112090	BT30 -SDM12 -90	2.5 ~ 12.0	90	34 ~ 44	0 ~ 5	32	HDP-12		
Shrink Fit	3920 00112105	-105	2.5 ~ 12.0	105	34 ~ 59	0 ~ 5	32	HDP-12	FDC-12	S-3L
	3920 00112120	-120	2.5 ~ 12.0	120	34 ~ 59	0 ~ 5	32	HDP-12		
	3920 00112135	-135	2.5 ~ 12.0	135	34 ~ 59	0 ~ 5	32	HDP-12		
	3920 00112150	-150	2.5 ~ 12.0	150	34 ~ 59	0 ~ 5	32	HDP-12		
Tapping Chuck	3920 00112165	-165	2.5 ~ 12.0	165	34 ~ 59	0 ~ 5	32	HDP-12	FDC-16	S-4L
	3920 00116105	BT30 -SDM16 -105	3.5 ~ 16.0	105	40 ~ 50	0 ~ 6	36	HDP-16		
	3920 00116120	-120	3.5 ~ 16.0	120	40 ~ 65	0 ~ 6	36	HDP-16		
	3920 00116135	-135	3.5 ~ 16.0	135	40 ~ 65	0 ~ 6	36	HDP-16		
	3920 00116150	-150	3.5 ~ 16.0	150	40 ~ 65	0 ~ 6	36	HDP-16		
Anchors	3920 00116165	-165	3.5 ~ 16.0	165	40 ~ 65	0 ~ 6	36	HDP-16	FDC-22	S-5L
	3920 00122105	BT30 -SDM22 -105	3.5 ~ 22.0	105	48 ~ 58	0 ~ 8	46	HDP-22		
	3920 00122120	-120	3.5 ~ 22.0	120	48 ~ 73	0 ~ 8	46	HDP-22		
	3920 00122135	-135	3.5 ~ 22.0	135	48 ~ 73	0 ~ 8	46	HDP-22		
	3920 00122150	-150	3.5 ~ 22.0	150	48 ~ 73	0 ~ 8	46	HDP-22		
Function Holder	3920 00122165	-165	3.5 ~ 22.0	165	48 ~ 73	0 ~ 8	46	HDP-22	FDC-07	S-0
	3920 00307090	BT40 -SDM07 -90	0.5 ~ 7.0	90	29 ~ 39	0 ~ 4	23	HDP-07A		
	3920 00307105	-105	0.5 ~ 7.0	105	29 ~ 54	0 ~ 4	23	HDP-07A		
	3920 00307120	-120	0.5 ~ 7.0	120	29 ~ 54	0 ~ 4	23	HDP-07A		
	3920 00307135	-135	0.5 ~ 7.0	135	29 ~ 54	0 ~ 4	23	HDP-07A		
Turning Tool	3920 00307150	-150	0.5 ~ 7.0	150	29 ~ 54	0 ~ 4	23	HDP-07A	FDC-09	S-1L
	3920 00309090	BT40 -SDM09 -90	2.5 ~ 9.0	90	28 ~ 38	0 ~ 4	26	HDP-09		
	3920 00309105	-105	2.5 ~ 9.0	105	28 ~ 53	0 ~ 4	26	HDP-09		
	3920 00309120	-120	2.5 ~ 9.0	120	28 ~ 53	0 ~ 4	26	HDP-09		
Retention Stud	3920 00309135	-135	2.5 ~ 9.0	135	28 ~ 53	0 ~ 4	26	HDP-09	FDC-09	S-1L
	3920 00309150	-150	2.5 ~ 9.0	150	28 ~ 53	0 ~ 4	26	HDP-09		
	3920 00309180	-180	2.5 ~ 9.0	180	28 ~ 53	0 ~ 4	26	HDP-09		

Código Code	Modelo Model	d	L	ℓ	B	D1	Tuerca ciega Nut	Boquilla Collet	Llave Inglesa Spanner		
3920 00312090	BT40 -SDM12 -90	2.5 ~ 12.0	90	34 ~ 44	0 ~ 5	32	HDP-12	FDC-12	S-3L		
3920 00312105	-105	2.5 ~ 12.0	105	34 ~ 59	0 ~ 5	32	HDP-12				
3920 00312120	-120	2.5 ~ 12.0	120	34 ~ 59	0 ~ 5	32	HDP-12				
3920 00312135	-135	2.5 ~ 12.0	135	34 ~ 59	0 ~ 5	32	HDP-12				
3920 00312150	-150	2.5 ~ 12.0	150	34 ~ 59	0 ~ 5	32	HDP-12				
3920 00312180	-180	2.5 ~ 12.0	180	34 ~ 59	0 ~ 5	32	HDP-12				
3920 00316105	BT40 -SDM16 -105	3.5 ~ 16.0	105	40 ~ 50	0 ~ 6	36	HDP-16	FDC-16	S-4L		
3920 00316120	-120	3.5 ~ 16.0	120	40 ~ 65	0 ~ 6	36	HDP-16				
3920 00316135	-135	3.5 ~ 16.0	135	40 ~ 65	0 ~ 6	36	HDP-16				
3920 00316150	-150	3.5 ~ 16.0	150	40 ~ 65	0 ~ 6	36	HDP-16				
3920 00316180	-180	3.5 ~ 16.0	180	40 ~ 65	0 ~ 6	36	HDP-16				
3920 00322120	BT40 -SDM22 -120	3.5 ~ 22.0	120	48 ~ 58	0 ~ 8	46	HDP-22			FDC-22	S-5L
3920 00322135	-135	3.5 ~ 22.0	135	48 ~ 73	0 ~ 8	46	HDP-22				
3920 00322150	-150	3.5 ~ 22.0	150	48 ~ 73	0 ~ 8	46	HDP-22				
3920 00322180	-180	3.5 ~ 22.0	180	48 ~ 73	0 ~ 8	46	HDP-22				
3920 00507090	BT50 -SDM07 -90	0.5 ~ 7.0	90	29 ~ 39	0 ~ 4	23	HDP-07A	FDC-07	S-0		
3920 00507105	-105	0.5 ~ 7.0	105	29 ~ 54	0 ~ 4	23	HDP-07A				
3920 00507120	-120	0.5 ~ 7.0	120	29 ~ 54	0 ~ 4	23	HDP-07A				
3920 00507135	-135	0.5 ~ 7.0	135	29 ~ 54	0 ~ 4	23	HDP-07A				
3920 00507150	-150	0.5 ~ 7.0	150	29 ~ 54	0 ~ 4	23	HDP-07A				
3920 00507165	-165	0.5 ~ 7.0	165	29 ~ 54	0 ~ 4	23	HDP-07A				
3920 00509090	BT50 -SDM09 -90	2.5 ~ 9.0	90	28 ~ 38	0 ~ 4	26	HDP-09	FDC-09	S-1L		
3920 00509105	-105	2.5 ~ 9.0	105	28 ~ 53	0 ~ 4	26	HDP-09				
3920 00509120	-120	2.5 ~ 9.0	120	28 ~ 53	0 ~ 4	26	HDP-09				
3920 00509135	-135	2.5 ~ 9.0	135	28 ~ 53	0 ~ 4	26	HDP-09				
3920 00509150	-150	2.5 ~ 9.0	150	28 ~ 53	0 ~ 4	26	HDP-09				
3920 00509180	-180	2.5 ~ 9.0	180	28 ~ 53	0 ~ 4	26	HDP-09				
3920 00512105	BT50 -SDM12 -105	2.5 ~ 12.0	105	34 ~ 44	0 ~ 5	32	HDP-12	FDC-12	S-3L		
3920 00512120	-120	2.5 ~ 12.0	120	34 ~ 59	0 ~ 5	32	HDP-12				
3920 00512135	-135	2.5 ~ 12.0	135	34 ~ 59	0 ~ 5	32	HDP-12				
3920 00512150	-150	2.5 ~ 12.0	150	34 ~ 59	0 ~ 5	32	HDP-12				
3920 00512180	-180	2.5 ~ 12.0	180	34 ~ 59	0 ~ 5	32	HDP-12				
3920 00516105	BT50 -SDM16 -105	3.5 ~ 16.0	105	40 ~ 50	0 ~ 6	36	HDP-16			FDC-16	S-4L
3920 00516120	-120	3.5 ~ 16.0	120	40 ~ 65	0 ~ 6	36	HDP-16				
3920 00516135	-135	3.5 ~ 16.0	135	40 ~ 65	0 ~ 6	36	HDP-16				
3920 00516150	-150	3.5 ~ 16.0	150	40 ~ 65	0 ~ 6	36	HDP-16				
3920 00516180	-180	3.5 ~ 16.0	180	40 ~ 65	0 ~ 6	36	HDP-16				
3920 00522120	BT50 -SDM22 -120	3.5 ~ 22.0	120	48 ~ 58	0 ~ 8	46	HDP-22	FDC-22	S-5L		
3920 00522135	-135	3.5 ~ 22.0	135	48 ~ 73	0 ~ 8	46	HDP-22				
3920 00522150	-150	3.5 ~ 22.0	150	48 ~ 73	0 ~ 8	46	HDP-22				
3920 00522180	-180	3.5 ~ 22.0	180	48 ~ 73	0 ~ 8	46	HDP-22				
3920 00522210	-210	3.5 ~ 22.0	210	48 ~ 73	0 ~ 8	46	HDP-22				

Boquilla Collet
Pág. 090-093



Llave Inglesa Spanner
Pág. 099



1. La boquilla y la llave inglesa se venden por separado.
2. ℓ es la dimensión entre el cabezal de la tuerca y el extremo superior del tornillo de preajuste.
3. Consulte la pág. 485 para conocer el Torque recomendado en nuestros productos.

1. Collet and spanner are sold separately.
2. ℓ is the dimension between the cap end and the preset screw top end.
3. See P.485 for standard Tightening Torque.

Ejemplo para Ordenar - Ordering Example

BT40	- SDM	12	-	90
Interfaz y diámetro de husillo Shank size		Máx. Diámetro Interno de boquilla Max. collet I.D.		Longitud de proyección Projection length (L)

High-Precision Collet Holder (High-Balanced Type)

- Adecuado para barrenado con rotación a alta velocidad, rima y acabado en fresa.
- Suitable for high speed rotation drilling, reaming, and finish endmilling.

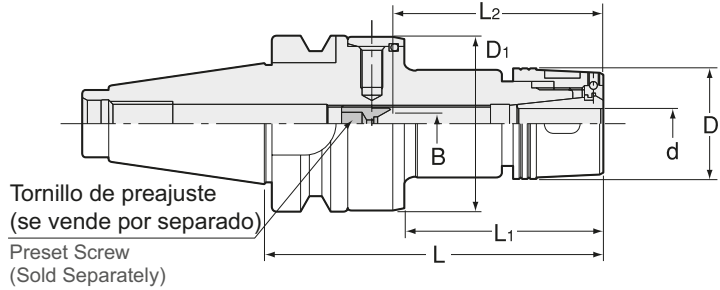

Unidad : Métrico
Unit : Metric

Código Code	Modelo Model	L	d	L1	L2	D	D1	kg	Tuerca ciega Nut	Boquilla Collet	Llave Inglesa Spanner
2446 03007090	BT30 -GDC07A -90	90	0.5 ~ 7.0	53	22 ~ 45	23	46	0.6	HDP-07A	FDC-07AA	S-0
2446 03007105	-105	105	0.5 ~ 7.0	68	22 ~ 45	23	46	0.7	HDP-07A	FDC-07AA	S-0
2446 03009090	BT30 -GDC09A -90	90	2.5 ~ 9.0	53	27 ~ 57	29	46	0.7	GDP-09	FDC-09AA	S-0
2446 03009105	-105	105	2.5 ~ 9.0	68	27 ~ 57	29	46	0.8	GDP-09	FDC-09AA	S-0
2446 03012090	BT30 -GDC12A -90	90	2.5 ~ 12.0	53	33 ~ 69	34	46	0.8	GDP-12	FDC-12AA	FK-0034
2446 03012105	-105	105	2.5 ~ 12.0	68	33 ~ 69	34	46	0.9	GDP-12	FDC-12AA	FK-0034
2446 03016090	BT30 -GDC16A -90	90	3.5 ~ 16.0	53	38 ~ 82	38	46	0.8	GDP-16	FDC-16AA	FK-0034
2446 03016120	-120	120	3.5 ~ 16.0	83	38 ~ 82	38	46	1.1	GDP-16	FDC-16AA	FK-0034
2446 04007090	BT40 -GDC07A -90	90	0.5 ~ 7.0	48	22 ~ 45	23	62	1.4	HDP-07A	FDC-07AA	S-0
2446 04007120	-120	120	0.5 ~ 7.0	78	22 ~ 45	23	62	1.5	HDP-07A	FDC-07AA	S-0
2446 04009090	BT40 -GDC09A -90	90	2.5 ~ 9.0	48	27 ~ 57	29	62	1.4	GDP-09	FDC-09AA	S-0
2446 04009120	-120	120	2.5 ~ 9.0	78	27 ~ 57	29	62	1.6	GDP-09	FDC-09AA	S-0
2446 04012090	BT40 -GDC12A -90	90	2.5 ~ 12.0	48	33 ~ 69	34	62	1.5	GDP-12	FDC-12AA	FK-0034
2446 04012120	-120	120	2.5 ~ 12.0	78	33 ~ 69	34	62	1.7	GDP-12	FDC-12AA	FK-0034
2446 04016090	BT40 -GDC16A -90	90	3.5 ~ 16.0	48	38 ~ 82	38	62	1.5	GDP-16	FDC-16AA	FK-0034
2446 04016120	-120	120	3.5 ~ 16.0	78	38 ~ 82	38	62	1.7	GDP-16	FDC-16AA	FK-0034
2446 04022090	BT40 -GDC22A -90	90	3.5 ~ 22.0	48	47 ~ 103	49	62	1.5	GDP-22	FDC-22AA	FK-0045
2446 04022105	-105	105	3.5 ~ 22.0	63	47 ~ 103	49	62	1.7	GDP-22	FDC-22AA	FK-0045
2446 04022135	-135	135	3.5 ~ 22.0	93	47 ~ 103	49	62	2.1	GDP-22	FDC-22AA	FK-0045
2446 05007105	BT50 -GDC07A -105	105	0.5 ~ 7.0	52	22 ~ 45	23	84	4.1	HDP-07A	FDC-07AA	S-0
2446 05007135	-135	135	0.5 ~ 7.0	82	22 ~ 45	23	84	4.3	HDP-07A	FDC-07AA	S-0
2446 05009105	BT50 -GDC09A -105	105	2.5 ~ 9.0	52	27 ~ 57	29	84	4.2	GDP-09	FDC-09AA	S-0
2446 05009135	-135	135	2.5 ~ 9.0	82	27 ~ 57	29	84	4.4	GDP-09	FDC-09AA	S-0
2446 05012105	BT50 -GDC12A -105	105	2.5 ~ 12.0	52	33 ~ 69	34	84	4.3	GDP-12	FDC-12AA	FK-0034
2446 05012135	-135	135	2.5 ~ 12.0	82	33 ~ 69	34	84	4.5	GDP-12	FDC-12AA	FK-0034
2446 05016105	BT50 -GDC16A -105	105	3.5 ~ 16.0	52	38 ~ 82	38	84	4.4	GDP-16	FDC-16AA	FK-0034
2446 05016135	-135	135	3.5 ~ 16.0	82	38 ~ 82	38	84	4.7	GDP-16	FDC-16AA	FK-0034
2446 05022105	BT50 -GDC22A -105	105	3.5 ~ 22.0	52	47 ~ 103	49	84	4.4	GDP-22	FDC-22AA	FK-0045
2446 05022135	-135	135	3.5 ~ 22.0	82	47 ~ 103	49	84	4.8	GDP-22	FDC-22AA	FK-0045

1. La boquilla, el tornillo de preajuste y la llave inglesa se venden por separado.

2. Siempre use boquillas de categoría "AA".

3. Consulte la pág. 088 para conocer la longitud mínima para insertar herramientas en caso de usar nuestras boquillas refrigerantes (OH, C o MS).

4. L2 indica la dimensión cuando se use con un tornillo de preajuste.

5. Consulte la pág. 485 para conocer el Torque recomendado para nuestros productos.

1. Collet, preset screw and spanner are sold separately.

2. Always use "AA" class collet.

3. Refer to P. 088 for minimum tool insertion length in case of using our coolant collets (OH,C or MS).

4. L2 indicates dimension when using with a preset screw.

5. See P.485 for standard Tightening Torque.

Boquilla
Collet

Pág. 090-093



Llave Inglesa
Spanner

Pág. 099



Tornillo de preajuste
Preset screw

Pág. 098



Ejemplo para Ordenar - Ordering Example

BT40 - GDC 09 A - 90

Interfaz y
diámetro
de husillo

Shank size

Máx. Diámetro
Interno de boquilla

Max. collet I.D.

Longitud de
proyección

Projection
length (L)

Collet Holder For Small Diameters

- Para barrenado en espacios reducidos.
- For drilling in tight space.

Tornillo de preajuste
 Portaherramienta ERC8: se vende por separado
 Portaherramientas con diferente diámetro a 8: incluido
Preset Screw
 ERC8 Holder : Sold separately
 Other Holder : Included

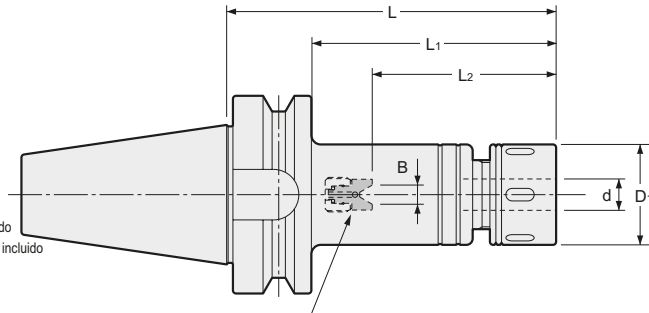

Unidad : Métrico
 Unit : Metric

Código Code	Modelo Model	d	L	L1	B	L2	D1	kg	Tornillo de preajuste Preset screw	Tuerca ciega Nut	Boquilla Collet	Llave Inglesa Spanner
2550 000108045	BT30 -ERC8* -45	0.020~0.197	1.772	0.906	— (0~0.094)	1.299 (0.748~1.220)	0.472	0.40	ER8 (sold separately)	ERP-8	ER8	S-8E
2550 000108060	-60	0.020~0.197	2.362	1.496	— (0~0.094)	1.299 (0.748~1.220)	0.472	0.40				
2550 000108075	-75	0.020~0.197	2.953	2.087	— (0~0.094)	1.299 (0.748~1.220)	0.472	0.41				
2550 000108090	-90	0.020~0.197	3.543	2.677	— (0~0.094)	1.299 (0.748~1.220)	0.472	0.41				
2550 000108105	-105	0.020~0.197	4.134	3.268	— (0~0.094)	1.299 (0.748~1.220)	0.472	0.42				
2550 000108135	-135	0.020~0.197	5.315	4.449	— (0~0.094)	1.299 (0.748~1.220)	0.472	0.45				
2550 000110045	BT30-ERC11S-45	0.020~0.276	1.772	0.906	0.0 ~ 0.157	0.866~1.457	0.630	0.40	HDS-07A-ES11	ERP-11S	ER11	S-11E
2550 000110060	-60	0.020~0.276	2.362	1.496	0.0 ~ 0.157	0.866~1.654	0.630	0.41				
2550 000110075	-75	0.020~0.276	2.953	2.087	0.0 ~ 0.157	0.866~1.654	0.630	0.43				
2550 000110090	-90	0.020~0.276	3.543	2.677	0.0 ~ 0.157	0.866~1.654	0.630	0.45				
2550 000110105	-105	0.020~0.276	4.134	3.268	0.0 ~ 0.157	0.866~1.654	0.630	0.46				
2550 000110135	-135	0.020~0.276	5.315	4.449	0.0 ~ 0.157	0.866~1.654	0.630	0.50				
2550 000111045	BT30 -ERC11 -45	0.020~0.276	1.772	0.906	0.0 ~ 0.157	0.866~1.457	0.906	0.43	HDP-07A			S-0
2550 000111060	-60	0.020~0.276	2.362	1.496	0.0 ~ 0.157	0.866~1.654	0.906	0.47				
2550 000111075	-75	0.020~0.276	2.953	2.087	0.0 ~ 0.157	0.866~1.654	0.906	0.50				
2550 000111090	-90	0.020~0.276	3.543	2.677	0.0 ~ 0.157	0.866~1.654	0.906	0.55				
2550 000111105	-105	0.020~0.276	4.134	3.268	0.0 ~ 0.157	0.866~1.654	0.906	0.55				
2550 000111115	-115	0.020~0.276	4.724	3.858	0.0 ~ 0.157	0.866~1.654	0.906	0.55				
2550 000116060	BT30 -ERC16 -60	0.020~0.394	2.362	1.496	0.0 ~ 0.197	1.299~1.929	1.260	0.53	ES16	ERP-16	ER16	FK-0030
2550 000116075	-75	0.020~0.394	2.953	2.087	0.0 ~ 0.197	1.299~2.126	1.260	0.61				
2550 000116090	-90	0.020~0.394	3.543	2.677	0.0 ~ 0.197	1.299~2.126	1.260	0.70				
2550 000116105	-105	0.020~0.394	4.134	3.268	0.0 ~ 0.197	1.299~2.126	1.260	0.78				
2550 000120060	BT30 -ERC20 -60	0.020~0.512	2.362	1.496	0.0 ~ 0.236	1.496~2.047	1.378	0.53	HDS12A-ES20	ERP-20	ER20	FK-0034
2550 000120075	-75	0.020~0.512	2.953	2.087	0.0 ~ 0.236	1.496~2.638	1.378	0.73				
2550 000120090	-90	0.020~0.512	3.543	2.677	0.0 ~ 0.236	1.496~2.638	1.378	0.73				
2550 000120105	-105	0.020~0.512	4.134	3.268	0.0 ~ 0.236	1.496~2.638	1.378	0.73				

- La boquilla y la llave inglesa se venden por separado.
- *El ES8, un tornillo de preajuste para el ERC8, se vende por separado. En portaherramientas de otros diámetros incluye un tornillo estándar de preajuste.
- Las dimensiones "B" e "l" sirven para usar el tornillo de preajuste ES8.
- Consulte la pág. 088 para conocer la longitud mínima para insertar herramientas en caso de usar nuestras boquillas refrigerantes.
- Consulte la pág. 485 para conocer el Torque recomendado para nuestros productos.
 - Collet and spanner are sold separately.
 - *ES8, a preset screw for ERC8, is sold separately. Other holder includes a standard preset screw.
 - " B " and " l " dimensions in brackets are for using ES8 preset screw.
 - Refer to P.088 for minimum tool insertion length in case of using our coolant collets.
 - See P.485 for standard Tightening Torque.

Boquilla Collet Pág. 094-095 	Llave Inglesa Spanner Pág. 099 	Tornillo de preajuste Preset screw Pág. 098 
--	--	---

Ejemplo para Ordenar - Ordering Example

BT30 - ERC	8	- 105
Interfaz y diámetro de husillo Shank size	Máx. Diámetro Interno de boquilla Max. collet I.D.	Longitud de proyección Projection length (L)

Collet Holder For Small Diameters

- Para barrenado en espacios reducidos.
- For drilling in tight space.

Tornillo de preajuste

Portaherramienta ERC8: se vende por separado
 Portaherramientas con diferente diámetro a 8: incluido
 Preset Screw
 ERC8 Holder : Sold separately
 Other Holder : Included

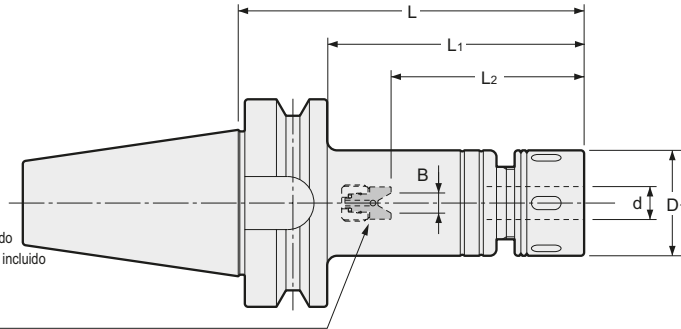

Unidad : Pulgadas
Unit : Inch

Código Code	Modelo Model	d	L	L1	B	L2	D1	kg	Tornillo de preajuste Preset screw	Tuerca ciega Nut	Boquilla Collet	Llave Inglesa Spanner
2550 000125060	BT30 -ERC25 -60	0.020~0.630	2.362	1.496	0.0 ~ 0.315	1.693~2.165	1.654	0.57	HDS16A-ES25	ERP-25	ER25	HS-1-16
2550 000125090	-90	0.020~0.630	3.543	2.677	0.0 ~ 0.315	1.693~3.150	1.654	0.85				
2550 000125105	-105	0.020~0.630	4.134	3.268	0.0 ~ 0.315	1.693~3.150	1.654	1.00				
2550 000125120	-120	0.020~0.630	4.724	3.858	0.0 ~ 0.315	1.693~3.150	1.654					
2550 000132060	BT30 -ERC32 -60	0.098~0.787	2.362	1.496	-	2.323	1.969		HDS22A-ER32	ERP-32	ER32	HS-2-20
2550 000132075	-75	0.098~0.787	2.953	2.087	-	2.913	1.969					
2550 000132090	-90	0.098~0.787	3.543	2.677	0.0 ~ 0.394	1.969~2.598	1.969					
2550 000132105	-105	0.098~0.787	4.134	3.268	0.0 ~ 0.394	1.969~3.189	1.969					
2550 000308060	BT40 -ERC8* -60	0.020~0.197	2.362	1.299	-	1.299	0.472	0.98	ER8 (sold separately)	ERP-8	ER8	S-8E
2550 000308075	-75	0.020~0.197	2.953	1.890	(0~0.094)	(0.748~1.220)	0.472	0.98				
2550 000308090	-90	0.020~0.197	3.543	2.480	(0~0.094)	(0.748~1.220)	0.472	0.98				
2550 000308105	-105	0.020~0.197	4.134	3.071	(0~0.094)	(0.748~1.220)	0.472	0.99				
2550 000308135	-135	0.020~0.197	5.315	4.252	(0~0.094)	(0.748~1.220)	0.472	1.01				
2550 000310060	BT40 -ERC11S -60	0.020~0.276	2.362	1.299	0.0 ~ 0.157	0.866~1.654	0.630	0.99	HDS-07A-ES11	ERP-11S	ER11	S-11E
2550 000310075	-75	0.020~0.276	2.953	1.890	0.0 ~ 0.157	0.866~1.654	0.630	1.00				
2550 000310090	-90	0.020~0.276	3.543	2.480	0.0 ~ 0.157	0.866~1.654	0.630	1.00				
2550 000310105	-105	0.020~0.276	4.134	3.071	0.0 ~ 0.157	0.866~1.654	0.630	1.02				
2550 000310135	-135	0.020~0.276	5.315	4.252	0.0 ~ 0.157	0.866~1.654	0.630	1.06				
2550 000311075	BT40 -ERC11 -75	0.020~0.276	2.953	1.890	0.0 ~ 0.157	0.866~1.654	0.906	1.07	HDS-07A-ES11	HDP-07A	ER11	S-0
2550 000311090	-90	0.020~0.276	3.543	2.480	0.0 ~ 0.157	0.866~1.654	0.906	1.10				
2550 000311105	-105	0.020~0.276	4.134	3.071	0.0 ~ 0.157	0.866~1.654	0.906	1.14				
2550 000316060	BT40 -ERC16 -60	0.020~0.394	2.362	1.299	0.0~0.197	1.299~2.126	1.260	1.09				
2550 000316090	-90	0.020~0.394	3.543	2.480	0.0~0.197	1.299~2.126	1.260	1.24				
2550 000316105	-105	0.020~0.394	4.134	3.071	0.0~0.197	1.299~2.126	1.260	1.31				
2550 000316120	-120	0.020~0.394	4.724	3.661	0.0~0.197	1.299~2.126	1.260					
2550 000316135	-135	0.020~0.394	5.315	4.252	0.0~0.197	1.299~2.126	1.260	1.46				
2550 000316165	-165	0.020~0.394	6.496	5.433	0.0~0.197	1.299~2.126	1.260					
2550 000320060	BT40 -ERC20 -60	0.020~0.512	2.362	1.299	0.0~0.236	1.496~2.244	1.378		HDS12A-ES20	ERP-20	ER20	FK-0034
2550 000320090	-90	0.020~0.512	3.543	2.480	0.0~0.236	1.496~2.638	1.378					
2550 000320105	-105	0.020~0.512	4.134	3.071	0.0~0.236	1.496~2.638	1.378	1.37				
2550 000320120	-120	0.020~0.512	4.724	3.661	0.0~0.236	1.496~2.638	1.378					
2550 000320135	-135	0.020~0.512	5.315	4.252	0.0~0.236	1.496~2.638	1.378	1.55				
2550 000320165	-165	0.020~0.512	6.496	5.433	0.0~0.236	1.496~2.638	1.378					
2550 000320195	-195	0.020~0.512	7.677	6.614	0.0~0.236	1.496~2.638	1.378					
2550 000325090	BT40 -ERC25 -90	0.020~0.630	3.543	2.480	0.0~0.315	1.693~3.150	1.654	1.39	HDS16A-ES25	ERP-25	ER25	HS-1-16
2550 000325105	-105	0.020~0.630	4.134	3.071	0.0~0.315	1.693~3.150	1.654					
2550 000325120	-120	0.020~0.630	4.724	3.661	0.0~0.315	1.693~3.150	1.654					
2550 000325135	-135	0.020~0.630	5.315	4.252	0.0~0.315	1.693~3.150	1.654					
2550 000325165	-165	0.020~0.630	6.496	5.433	0.0~0.315	1.693~3.150	1.654					
2550 000325195	-195	0.020~0.630	7.677	6.614	0.0~0.315	1.693~3.150	1.654					

Código Code	Modelo Model	d	L	L1	B	L2	D1	kg	Tornillo de preajuste Preset screw	Tuerca ciega Nut	Boquilla Collet	Llave Inglesa Spanner
2550 000332075	BT40 -ERC32 -75	0.098~0.787	2.953	1.890	0.0~0.394	1.969~2.795	1.969	1.28	HDS22A-ES32	ERP-32	ER32	HS-2-20
2550 000332105	-105	0.098~0.787	4.134	3.071	0.0~0.394	1.969~3.976	1.969	1.63				
2550 000332120	-120	0.098~0.787	4.724	3.661	0.0~0.394	1.969~3.976	1.969	1.84				
2550 000332135	-135	0.098~0.787	5.315	4.252	0.0~0.394	1.969~3.976	1.969					
2550 000332165	-165	0.098~0.787	6.496	5.433	0.0~0.394	1.969~3.976	1.969					
2550 000332195	-195	0.098~0.787	7.677	6.614	0.0~0.394	1.969~3.976	1.969					
2550 000340075	BT40 -ERC40 -75	0.118~1.024	2.953	1.890	-	3.386	2.480	1.26	-	ERP40	ER40	HS-2.5-25
2550 000340105	-105	0.118~1.024	4.134	3.071	0.0~0.551	2.632~3.504	2.480	1.92	ES40			
2550 000340150	-150	0.118~1.024	5.906	4.843	0.0~0.551	2.632~3.898	2.480					
2550 000511090	BT50 -ERC11 -90	0.020~0.276	3.543	2.047	0.0~0.157	0.866~1.654	0.906		HDS07A-ES11	HDP-07A	ER11	S-0
2550 000511105	-105	0.020~0.276	4.134	2.638	0.0~0.157	0.866~1.654	0.906					
2550 000511120	-120	0.020~0.276	4.724	3.228	0.0~0.157	0.866~1.654	0.906					
2550 000511135	-135	0.020~0.276	5.315	3.819	0.0~0.157	0.866~1.654	0.906					
2550 000511165	-165	0.020~0.276	6.496	5.000	0.0~0.157	0.866~1.654	0.906					
2550 000511195	-195	0.020~0.276	7.677	6.181	0.0~0.157	0.866~1.654	0.906					
2550 000516090	BT50 -ERC16 -90	0.020~0.394	3.543	2.047	0.0~0.197	1.299~2.126	1.260		ES16	ERP-16	ER16	FK-0030
2550 000516105	-105	0.020~0.394	4.134	2.638	0.0~0.197	1.299~2.126	1.260					
2550 000516120	-120	0.020~0.394	4.724	3.228	0.0~0.197	1.299~2.126	1.260					
2550 000516135	-135	0.020~0.394	5.315	3.819	0.0~0.197	1.299~2.126	1.260					
2550 000516165	-165	0.020~0.394	6.496	5.000	0.0~0.197	1.299~2.126	1.260					
2550 000516195	-195	0.020~0.394	7.677	6.181	0.0~0.197	1.299~2.126	1.260					
2550 000516225	-225	0.020~0.394	8.858	7.362	0.0~0.197	1.299~2.126	1.260					
2550 000516255	-255	0.020~0.394	10.039	8.543	0.0~0.197	1.299~2.126	1.260					
2550 000520090	BT50 -ERC20 -90	0.020~0.512	3.543	2.047	0.0~0.236	1.496~2.638	1.378	3.80	HDS12A-ES20	ERP-20	ER20	FK-0034
2550 000520105	-105	0.020~0.512	4.134	2.638	0.0~0.236	1.496~2.638	1.378					
2550 000520120	-120	0.020~0.512	4.724	3.228	0.0~0.236	1.496~2.638	1.378					
2550 000520135	-135	0.020~0.512	5.315	3.819	0.0~0.236	1.496~2.638	1.378	4.04				
2550 000520165	-165	0.020~0.512	6.496	5.000	0.0~0.236	1.496~2.638	1.378					
2550 000520195	-195	0.020~0.512	7.677	6.181	0.0~0.236	1.496~2.638	1.378					
2550 000520225	-225	0.020~0.512	8.858	7.362	0.0~0.236	1.496~2.638	1.378					
2550 000520255	-255	0.020~0.512	10.039	8.543	0.0~0.236	1.496~2.638	1.378	4.79				
2550 000525090	BT50 -ERC25 -90	0.020~0.630	3.543	2.047	0.0~0.315	1.693~3.150	1.654		HDS16A-ES25	ERP-25	ER25	HS-1-16
2550 000525105	-105	0.020~0.630	4.134	2.638	0.0~0.315	1.693~3.150	1.654					
2550 000525120	-120	0.020~0.630	4.724	3.228	0.0~0.315	1.693~3.150	1.654					
2550 000525135	-135	0.020~0.630	5.315	3.819	0.0~0.315	1.693~3.150	1.654					
2550 000525165	-165	0.020~0.630	6.496	5.000	0.0~0.315	1.693~3.150	1.654					
2550 000525195	-195	0.020~0.630	7.677	6.181	0.0~0.315	1.693~3.150	1.654					
2550 000525225	-225	0.020~0.630	8.858	7.362	0.0~0.315	1.693~3.150	1.654					
2550 000525255	-255	0.020~0.630	10.039	8.543	0.0~0.315	1.693~3.150	1.654					
2550 000532105	BT50 -ERC32 -105	0.098~0.787	4.134	2.638	0.0~0.394	1.969~3.976	1.969	4.11	HDS22A-ES32	ERP-32	ER32	HS-2-20
2550 000532120	-120	0.098~0.787	4.724	3.228	0.0~0.394	1.969~3.976	1.969					
2550 000532135	-135	0.098~0.787	5.315	3.819	0.0~0.394	1.969~3.976	1.969					
2550 000532165	-165	0.098~0.787	6.496	5.000	0.0~0.394	1.969~3.976	1.969	4.87				
2550 000532195	-195	0.098~0.787	7.677	6.181	0.0~0.394	1.969~3.976	1.969					
2550 000532225	-225	0.098~0.787	8.858	7.362	0.0~0.394	1.969~3.976	1.969					
2550 000532255	-255	0.098~0.787	10.039	8.543	0.0~0.394	1.969~3.976	1.969	5.99				
2550 000540105	BT50 -ERC40 -105	0.118~1.024	4.134	2.638	0.0~0.551	2.362~3.898	2.480	4.29	ES40	ERP-40	ER40	HS-2.5-25
2550 000540165	-165	0.118~1.024	6.496	5.000	0.0~0.551	2.362~3.898	2.480	5.58				
2550 000550105	BT50 -ERC50 -105	0.394~1.339	4.134	2.638	0.0~0.630	2.913~3.937	3.071		ES50	ERP-50	ER50	HS-4-42

1. La boquilla y la llave inglesa se venden por separado.
2. *El ES8, un tornillo de preajuste para el ERC8, se vende por separado. El otro portaherramienta incluye un tornillo estándar de preajuste.
3. Las dimensiones "B" e "l" sirven para usar el tornillo de preajuste ES8.
4. Consulte la pág. 088 para conocer la longitud mínima para insertar herramientas en caso de usar nuestras boquillas refrigerantes.
5. Consulte la pág. 485 para conocer el Torque recomendado para nuestros productos.

1. Collet and spanner are sold separately.
2. *ES8, a preset screw for ERC8, is sold separately. Other holder includes a standard preset screw.
3. " B " and " l " dimensions in brackets are for using ES8 preset screw.
4. Refer to P.088 for minimum tool insertion length in case of using our coolant collets.
5. See P.485 for standard Tightening Torque.

Boquilla Collet
Pág. 094-095



Llave Inglesa Spanner
Pág. 099



Tornillo de preajuste Preset screw
Pág. 098



Ejemplo para Ordenar - Ordering Example

BT40 - ERC 8 - 105
 Interfaz y diámetro de husillo Máx. Diámetro Interno de boquilla Longitud de proyección
 Shank size Max. collet I.D. Projection length (L)

ERC-T

Collet Holder For Small Diameters (Taper Type)

- Para barrenado en espacios reducidos.
- For drilling in tight space.

Tornillo de preajuste

Portaherramienta ERC8: se vende por separado
Portaherramienta con diferente diámetro a 8: incluido

Preset Screw

ERC8 Holder : Sold separately
Other Holder : Included

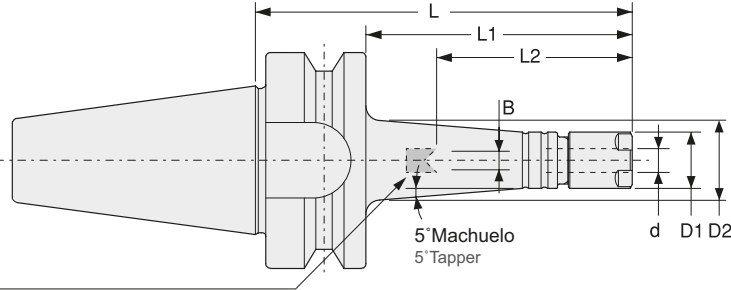

Unidad : Métrico
Unit : Metric

Código Code	Modelo Model	d	L	L1	B	L2	D1	D2	Tuerca ciega Nut	Boquilla Collet	Llave Inglesa Spanner
2550 10108060	BT30 -ERC8* -60T	0.5 ~ 5.0	60	38	— (0 ~ 2.4)	³⁴ (19 ~ 31)	12	14.5	ERP-8	ER8	S-8E
2550 10108075	-75T	0.5 ~ 5.0	75	53	— (0 ~ 2.4)	³⁴ (19 ~ 31)	12	17.5	ERP-8		
2550 10108090	-90T	0.5 ~ 5.0	90	68	— (0 ~ 2.4)	³⁴ (19 ~ 31)	12	20	ERP-8		
2550 10108105	-105T	0.5 ~ 5.0	105	83	— (0 ~ 2.4)	³⁴ (19 ~ 31)	12	22.5	ERP-8		
2550 10108135	-135T	0.5 ~ 5.0	135	113	— (0 ~ 2.4)	³⁴ (19 ~ 31)	12	28	ERP-8		
2550 10110060	BT30 -ERC11S -60T	0.5 ~ 7.0	60	38	0 ~ 4	22 ~ 45	16	18.5	ERP-11S	ER11	S-11E
2550 10110075	-75T	0.5 ~ 7.0	75	53	0 ~ 4	22 ~ 45	16	21	ERP-11S		
2550 10110090	-90T	0.5 ~ 7.0	90	68	0 ~ 4	22 ~ 45	16	24	ERP-11S		
2550 10110105	-105T	0.5 ~ 7.0	105	83	0 ~ 4	22 ~ 45	16	26.5	ERP-11S		
2550 10110135	-135T	0.5 ~ 7.0	135	113	0 ~ 4	22 ~ 45	16	31.5	ERP-11S		
2550 10308060	BT40 -ERC8 -60T	0.5 ~ 5.0	60	33	— (0 ~ 2.4)	³⁴ (19 ~ 31)	12	14	ERP-8	ER8	S-8E
2550 10308075	-75T	0.5 ~ 5.0	75	48	— (0 ~ 2.4)	³⁴ (19 ~ 31)	12	16.5	ERP-8		
2550 10308090	-90T	0.5 ~ 5.0	90	63	— (0 ~ 2.4)	³⁴ (19 ~ 31)	12	19	ERP-8		
2550 10308105	-105T	0.5 ~ 5.0	105	78	— (0 ~ 2.4)	³⁴ (19 ~ 31)	12	21.5	ERP-8		
2550 10308135	-135T	0.5 ~ 5.0	135	108	— (0 ~ 2.4)	³⁴ (19 ~ 31)	12	27	ERP-8		
2550 10310060	BT40 -ERC11S -60T	0.5 ~ 7.0	60	33	0 ~ 4	22 ~ 45	16	17.5	ERP-11S	ER11	S-11E
2550 10310075	-75T	0.5 ~ 7.0	75	48	0 ~ 4	22 ~ 45	16	20.5	ERP-11S		
2550 10310090	-90T	0.5 ~ 7.0	90	63	0 ~ 4	22 ~ 45	16	23	ERP-11S		
2550 10310105	-105T	0.5 ~ 7.0	105	78	0 ~ 4	22 ~ 45	16	25.5	ERP-11S		
2550 10310135	-135T	0.5 ~ 7.0	135	108	0 ~ 4	22 ~ 45	16	31	ERP-11S		

1. La boquilla y la llave inglesa se venden por separado.
- 2.*El ES8, un tornillo de preajuste para el ERC8, se vende por separado. El ERC11S incluye un tornillo estándar de preajuste.
- 3.Las dimensiones "B" y "L2" sirven para usar el tornillo de preajuste ES8.
- 4.Consulte la pág. 088 para conocer la longitud mínima para insertar herramientas en caso de usar nuestras boquillas refrigerantes.
- 5.Consulte la pág. 485 para conocer el Torque recomendado para nuestros productos.

- 1.Collet and spanner are sold separately.
- 2.*ES8, a preset screw for ERC8, is sold separately. ERC11S includes a standard preset screw HDS-07A-ES11.
- 3." B " and " L2 " dimensions in brackets are for using ES8 preset screw.
- 4.Refer to P. 088 for minimum tool insertion length in case of using our coolant collets.
- 5.See P.485 for standard Tightening Torque.

Boquilla Collet Pág. 094-095	Llave Inglesa Spanner Pág. 099	Tornillo de preajuste Preset screw Pág. 098

Ejemplo para Ordenar - Ordering Example

BT40 - ERC	8	- 105 T
Interfaz y diámetro de husillo Shank size	Máx. Diámetro Interno de boquilla Max. collet I.D.	Longitud de proyección Projection length (L)

ST-HDC·A

Flex Chuck

- Para barrenado en espacios reducidos. Así mismo, es apropiado para usarse como una extensión del portaherramienta de fresado.
- For drilling in tight space. Also suitable as sub-holder of milling chuck.

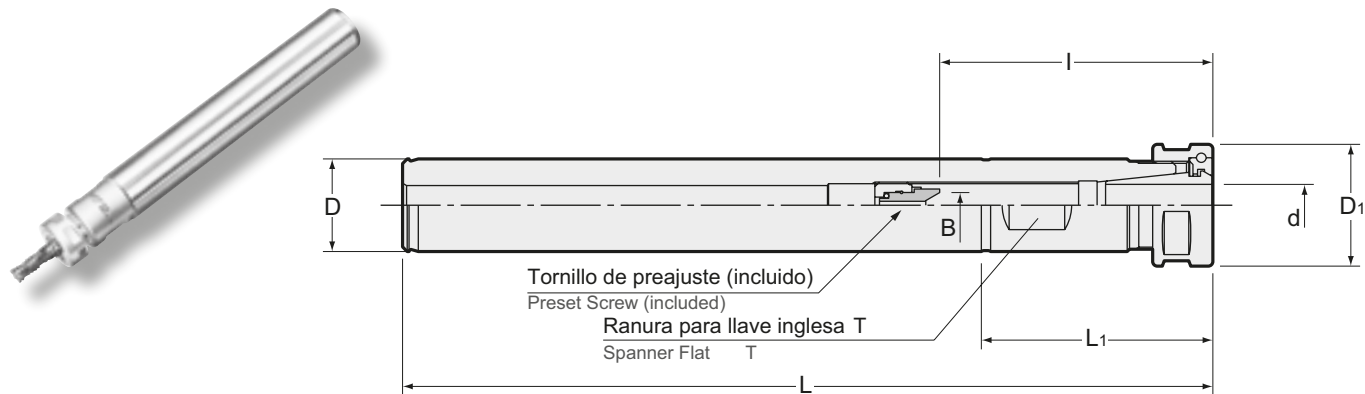

Medidas Métricas - Metric Sizes (Zanco - Shank)

Unidad : Métrico
Unit : Metric

Código Code	Modelo Model	d	D _{0.012}	D1	L	L1	B	I	T	kg	Tornillo de preajuste Preset screw	Tuerca ciega Nut	Boquilla Collet	Llave Inglesa Spanner
0400 12009175	ST20 -HDC09A -175	2.5~9.0	20	26	175	50	0~4	27~56	17	0.4	HDS-09	HDP-09	FDC-09	S-1L
0400 13212185	ST32 -HDC12A -185	2.5~12.0	32	32	185	51	0~6	34~70	29	1.0	HDS-12	HDP-12	FDC-12	S-3L
0400 13212235	-235	2.5~12.0	32	32	235	51	0~6	34~70	29	1.2	HDS-12	HDP-12		

1. La boquilla, llave inglesa, tornillo Allen opresor de preajuste y el tornillo de preajuste para procesos semisecos se venden por separado. El tornillo estándar de preajuste está incluido.
2. Consulte la pág. 088 para conocer la longitud mínima para insertar herramientas en caso de usar nuestras boquillas refrigerantes (OH, C o MS) y la herramienta con espiga.
3. Consulte la pág. 485 para conocer el Torque recomendado para nuestros productos.

1. Collet, spanner, hexagon head preset screw, preset screw for semi-dry processing are sold separately. Standard preset screw is included.
2. Refer to P. 088 for minimum tool insertion length in case of using our coolant collets (OH,C or MS) and tool with tang.
3. See P.485 for standard Tightening Torque.

Ejemplo para Ordenar - Ordering Example

ST20 - HDC 09 A - 175

Interfaz y diámetro de husillo
Shank size

Máx. Diámetro Interno de boquilla
Max. collet I.D.

Longitud de proyección
Projection length (L)

Medida en Pulgadas - Inch Sizes (Zanco - Shank)

Unidad : Pulgadas
Unit : Inch

Código Code	Modelo Model	d	D _{0.0005}	D1	L	L1	B	I	T	kg	Tornillo de preajuste Preset screw	Tuerca ciega Nut	Boquilla Collet	Llave Inglesa Spanner
0400 22409175	ST0750 -HDC09A -175	0.098~0.354	0.750	1.024	6.890	1.969	0.0~0.157	1.063~2.126	0.669 (17mm)	0.4	HDS-09	HDP-09	FDC-09	S-1L
0400 24012185	ST1250 -HDC12A -185	0.098~0.472	1.250	1.260	7.283	2.008	0.0~0.236	1.338~2.598	1.142 (29mm)	1.0	HDS-12	HDP-12	FDC-12	S-3L
0400 24012235	-235	0.098~0.472	1.250	1.260	9.252	2.008	0.0~0.236	1.338~2.598	1.142 (29mm)		HDS-12	HDP-12		

1. La boquilla, llave inglesa, tornillo Allen opresor de preajuste y el tornillo de preajuste para procesos semisecos se venden por separado. El tornillo estándar de preajuste está incluido.
2. Consulte la pág. 088 para conocer la longitud mínima para insertar herramientas en caso de usar nuestras boquillas refrigerantes (OH, C o MS) y la herramienta con espiga.
3. Consulte la pág. 485 para conocer el Torque recomendado para nuestros productos.

1. Collet, spanner, hexagon head preset screw, preset screw for semi-dry processing are sold separately. Standard preset screw is included.
2. Refer to P. 088 for minimum tool insertion length in case of using our coolant collets (OH,C or MS) and tool with tang.
3. See P.485 for standard Tightening Torque.

Boquilla Collet
Pág. 090-093

Llave Inglesa Spanner
Pág. 099

Tornillo de preajuste Preset screw
Pág. 098

Ejemplo para Ordenar - Ordering Example

ST0750 - HDC 09 A - 175

Interfaz y diámetro de husillo
Shank size

Máx. Diámetro Interno de boquilla
Max. collet I.D.

Longitud de proyección
Projection length (L)

ST-HDZ

"R"Zero Holder

- Portaherramienta de boquilla con una funcionalidad de ajuste de excentricidad. Apropiado para barrenado en espacios reducidos y para usarse como extensión del portaherramienta de fresado.
- Collet holder with a runout adjustment function. Suitable for drilling in tight space as well as use for sub-holder of milling chuck.

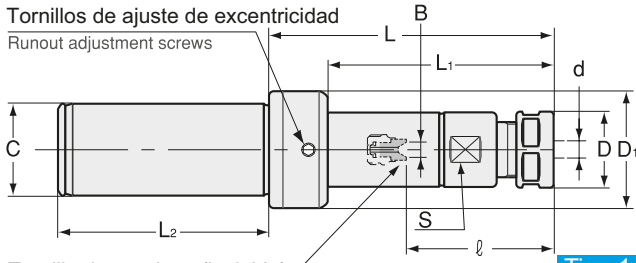

Tornillo de preajuste (incluido)
Preset Screw (included)

Tipo 1
Type1

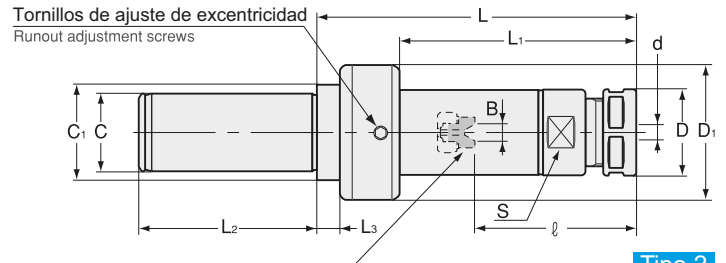

Tornillo de preajuste (incluido)
Preset Screw (included)

Tipo 2
Type2

Medidas Métricas - Metric Sizes (Zanco - Shank)

Unidad : Métrico
Unit : Metric

Código Code	Modelo Model	Tipo Type	d	C ₀ ^{0-0.012}	C1	L	L1	L2	L3	B	ℓ	D	D1	S	kg	Tornillo de preajuste Preset Screw	Tuerca ciega Nut	Boquilla Collet	Llave Inglesa Spanner	Llave Allen Hex. Wrench
3100 02007075	ST20 -HDZ07 -75	2	0.5-7.0	20	28	75	44	57	10	0-4	22-45	23	41	19		HDS-07	HDP-07A			
3100 02007120	-120	2	0.5-7.0	20	28	120	89	57	10	0-4	22-45	23	41	19		HDS-07	HDP-07A	FDC-07	S-0	L-3T
3100 02007165	-165	2	0.5-7.0	20	28	165	134	57	10	0-4	22-45	23	41	19		HDS-07	HDP-07A			
3100 02009075	ST20 -HDZ09 -75	2	2.5-9.0	20	28	75	44	57	10	0-4	27-60	26	41	24	0.5	HDS-09	HDP-09			
3100 02009120	-120	2	2.5-9.0	20	28	120	89	57	10	0-4	27-60	26	41	24	0.6	HDS-09	HDP-09	FDC-09	S-1L	L-3T
3100 02009165	-165	2	2.5-9.0	20	28	165	134	57	10	0-4	27-60	26	41	24		HDS-09	HDP-09			
3100 03207060	ST32 -HDZ07 -60	1	0.5-7.0	32	—	60	39	70	—	0-4	22-45	23	41	19	0.7	HDS-07	HDP-07A			
3100 03207105	-105	1	0.5-7.0	32	—	105	84	70	—	0-4	22-45	23	41	19		HDS-07	HDP-07A	FDC-07	S-0	L-3T
3100 03207150	-150	1	0.5-7.0	32	—	150	129	70	—	0-4	22-45	23	41	19		HDS-07	HDP-07A			
3100 03209075	ST32 -HDZ09 -75	1	2.5-9.0	32	—	75	54	70	—	0-4	27-60	26	41	24		HDS-09	HDP-09			
3100 03209120	-120	1	2.5-9.0	32	—	120	99	70	—	0-4	27-60	26	41	24		HDS-09	HDP-09	FDC-09	S-1L	L-3T
3100 03209165	-165	1	2.5-9.0	32	—	165	144	70	—	0-4	27-60	26	41	24		HDS-09	HDP-09			
3100 03212090	ST32 -HDZ12 -90	2	2.5-12.0	32	40	90	55	70	10	0-5	33-69	32	52	30	1.0	HDS-12	HDP-12			
3100 03212135	-135	2	2.5-12.0	32	40	135	100	70	10	0-5	33-69	32	52	30	1.3	HDS-12	HDP-12	FDC-12	S-3L	L-4T
3100 03212180	-180	2	2.5-12.0	32	40	180	145	70	10	0-5	33-69	32	52	30		HDS-12	HDP-12			
3100 03216090	ST32 -HDZ16 -90	2	3.5-16.0	32	40	90	55	70	10	0-6	38-82	36	56	30	1.1	HDS-16	HDP-16			
3100 03216135	-135	2	3.5-16.0	32	40	135	100	70	10	0-6	38-82	36	56	30		HDS-16	HDP-16	FDC-16	S-4L	L-4T
3100 03216180	-180	2	3.5-16.0	32	40	180	145	70	10	0-6	38-82	36	56	30		HDS-16	HDP-16			
3100 03222105	ST32 -HDZ22 -105	2	3.5-22.0	32	40	105	64	70	7	0-8	47-73	46	69	42	1.6	HDS-22	HDP-22			
3100 03222150	-150	2	3.5-22.0	32	40	150	109	70	7	0-8	47-103	46	69	42	2.1	HDS-22	HDP-22	FDC-22	S-5L	L-5T
3100 03222195	-195	2	3.5-22.0	32	40	195	154	70	7	0-8	47-103	46	69	42		HDS-22	HDP-22			
3100 04212090	ST42 -HDZ12 -90	1	2.5-12.0	42	—	90	65	75	—	0-5	33-69	32	52	30		HDS-12	HDP-12			
3100 04212135	-135	1	2.5-12.0	42	—	135	110	75	—	0-5	33-69	32	52	30		HDS-12	HDP-12	FDC-12	S-3L	L-4T
3100 04212180	-180	1	2.5-12.0	42	—	180	155	75	—	0-5	33-69	32	52	30		HDS-12	HDP-12			
3100 04216090	ST42 -HDZ16 -90	1	3.5-16.0	42	—	90	65	75	—	0-6	38-82	36	56	30		HDS-16	HDP-16			
3100 04216135	-135	1	3.5-16.0	42	—	135	110	75	—	0-6	38-82	36	56	30		HDS-16	HDP-16	FDC-16	S-4L	L-4T
3100 04216180	-180	1	3.5-16.0	42	—	180	155	75	—	0-6	38-82	36	56	30		HDS-16	HDP-16			
3100 04222105	ST42 -HDZ22 -105	2	3.5-22.0	42	52	105	64	75	7	0-8	47-103	46	69	42		HDS-22	HDP-22			
3100 04222150	-150	2	3.5-22.0	42	52	150	109	75	7	0-8	47-103	46	69	42		HDS-22	HDP-22	FDC-22	S-5L	L-5T
3100 04222195	-195	2	3.5-22.0	42	52	195	154	75	7	0-8	47-103	46	69	42		HDS-22	HDP-22			

1. La boquilla, llave inglesa, tornillo Allen opresor de preajuste y el tornillo de preajuste para procesos semisecos se venden por separado. El tornillo estándar de preajuste está incluido.
 2. Consulte la pág. 088 para conocer la longitud mínima para insertar herramientas en caso de usar nuestras boquillas refrigerantes (OH, C o MS).
 3. ℓ indica la dimensión al usar el tornillo de preajuste.
 4. Consulte la pág. 485 para conocer el Torque recomendado para nuestros productos.
1. Collet, spanner, hexagon head preset screw, preset screw for semi-dry processing, and adjustment wrench are sold separately. Standard preset screw is included.
 2. Refer to P. 088 for minimum tool insertion length in case of using our coolant collets (OH, C or MS).
 3. ℓ indicates dimension when using with a preset screw.
 4. See P.485 for standard Tightening Torque.

Boquilla Collet	Llave Inglesa Spanner	Tornillo de preajuste Preset screw	Llave Allen Adjustment wrench	Ejemplo para Ordenar - Ordering Example		
Pág. 090-093	Pág. 099	Pág. 098	Pág. 099	ST32	- HDZ	12 - 90
				Interfaz y diámetro de husillo	Máx. Diámetro Interno de boquilla	Longitud de proyección
				Shank size	Max. collet I.D.	Projection length (L)

Pulgada a métrico → Pulgada × 25.4
Métrico a pulgada → Métrico ÷ 25.4 ó métrico por 0.03937







Tamaños especiales / personalizados bajo pedido

Medida en Pulgadas - Inch Sizes (Zanco - Shank)

Unidad : Pulgadas
Unit : Inch

Código Code	Modelo Model	Tipo Type	d	C ₀ -0.0005	C1	L	ℓ	L1	L2	L3	B	D	D1	S	kg	Tornillo de preajuste Preset Screw	Tuerca ciega Nut	Boquilla Collet	Llave Inglesa Spanner	Llave Allen Hex. Wrench
3100 12407075	ST0750 -HDZ07 -75	2	0.020~0.276	0.750	1.102	2.953	0.866~1.772	1.732	2.24	0.39	0.0~0.157	0.906	1.614	0.748 (19mm)	0.6	HDS-07	HDP-07A	FDC-07	S-0	L-3T (3mm)
3100 12407120	-120	2	0.020~0.276	0.750	1.102	4.724	0.866~1.772	3.504	2.24	0.39	0.0~0.157	0.906	1.614	0.748 (19mm)		HDS-07	HDP-07A			
3100 12407165	-165	2	0.020~0.276	0.750	1.102	6.496	0.866~1.772	5.276	2.24	0.39	0.0~0.157	0.906	1.614	0.748 (19mm)		HDS-07	HDP-07A			
3100 12409075	ST0750 -HDZ09 -75	2	0.098~0.354	0.750	1.102	2.953	1.063~2.244	1.732	2.24	0.39	0.0~0.157	1.024	1.614	0.945 (24mm)		HDS-09	HDP-09	FDC-09	S-1L	L-3T (3mm)
3100 12409120	-120	2	0.098~0.354	0.750	1.102	4.724	1.063~2.244	3.504	2.24	0.39	0.0~0.157	1.024	1.614	0.945 (24mm)		HDS-09	HDP-09			
3100 12409165	-165	2	0.098~0.354	0.750	1.102	6.496	1.063~2.244	5.276	2.24	0.39	0.0~0.157	1.024	1.614	0.945 (24mm)		HDS-09	HDP-09			
3100 14007060	ST1250 -HDZ07 -60	1	0.020~0.276	1.250	—	2.362	0.866~1.772	1.535	2.76	—	0.0~0.157	0.906	1.614	0.748 (19mm)		HDS-07	HDP-07A	FDC-07	S-0	L-3T (3mm)
3100 14007105	-105	1	0.020~0.276	1.250	—	4.134	0.866~1.772	3.307	2.76	—	0.0~0.157	0.906	1.614	0.748 (19mm)		HDS-07	HDP-07A			
3100 14007150	-150	1	0.020~0.276	1.250	—	5.906	0.866~1.772	5.079	2.76	—	0.0~0.157	0.906	1.614	0.748 (19mm)		HDS-07	HDP-07A			
3100 14009075	ST1250 -HDZ09 -75	1	0.098~0.354	1.250	—	2.953	1.063~2.244	2.126	2.76	—	0.0~0.157	1.024	1.614	0.945 (24mm)		HDS-09	HDP-09	FDC-09	S-1L	L-3T (3mm)
3100 14009120	-120	1	0.098~0.354	1.250	—	4.724	1.063~2.244	3.898	2.76	—	0.0~0.157	1.024	1.614	0.945 (24mm)		HDS-09	HDP-09			
3100 14009165	-165	1	0.098~0.354	1.250	—	6.496	1.063~2.244	5.669	2.76	—	0.0~0.157	1.024	1.614	0.945 (24mm)		HDS-09	HDP-09			
3100 14012090	ST1250 -HDZ12 -90	2	0.098~0.472	1.250	1.575	3.543	1.299~2.677	2.165	2.76	0.39	0.0~0.197	1.260	2.047	1.811 (30mm)		HDS-12	HDP-12	FDC-12	S-3L	L-4T (4mm)
3100 14012135	-135	2	0.098~0.472	1.250	1.575	5.315	1.299~2.677	3.937	2.76	0.39	0.0~0.197	1.260	2.047	1.811 (30mm)		HDS-12	HDP-12			
3100 14012180	-180	2	0.098~0.472	1.250	1.575	7.087	1.299~2.677	5.709	2.76	0.39	0.0~0.197	1.260	2.047	1.811 (30mm)		HDS-12	HDP-12			
3100 14016090	ST1250 -HDZ16 -90	2	0.138~0.630	1.250	1.575	3.543	1.496~3.189	2.165	2.76	0.39	0.0~0.236	1.417	2.205	1.811 (30mm)	1.1	HDS-16	HDP-16	FDC-16	S-4L	L-5T (5mm)
3100 14016135	-135	2	0.138~0.630	1.250	1.575	5.315	1.496~3.189	3.937	2.76	0.39	0.0~0.236	1.417	2.205	1.811 (30mm)	1.4	HDS-16	HDP-16			
3100 14016180	-180	2	0.138~0.630	1.250	1.575	7.087	1.496~3.189	5.709	2.76	0.39	0.0~0.236	1.417	2.205	1.811 (30mm)	1.7	HDS-16	HDP-16			
3100 14022105	ST1250 HDZ22 -105	2	0.318~0.866	1.250	1.575	4.134	1.850~2.874	2.520	2.76	0.28	0.0~0.315	1.811	2.717	1.654 (42mm)		HDS-22	HDP-22	FDC-22	S-5L	L-5T (5mm)
3100 14022150	-150	2	0.318~0.866	1.250	1.575	5.906	1.850~4.055	4.291	2.76	0.28	0.0~0.315	1.811	2.717	1.654 (42mm)		HDS-22	HDP-22			
3100 14022195	-195	2	0.318~0.866	1.250	1.575	7.677	1.850~4.055	6.063	2.76	0.28	0.0~0.315	1.811	2.717	1.654 (42mm)		HDS-22	HDP-22			

1. La boquilla, llave inglesa, tornillo Allen opresor de preajuste y el tornillo de preajuste para procesos semisecos se venden por separado. El tornillo estándar de pre-ajuste está incluido.
2. Consulte la pág. 088 para conocer la longitud mínima para insertar herramientas en caso de usar nuestras boquillas refrigerantes (OH, C o MS).
3. ℓ indica la dimensión al usar el tornillo de preajuste.
4. Consulte la pág. 485 para conocer el Torque recomendado para nuestros productos.
1. Collet, spanner, hexagon head preset screw, preset screw for semi-dry processing, and adjustment wrench are sold separately. Standard preset screw is included.
2. Refer to P. 088 for minimum tool insertion length in case of using our coolant collets (OH,C or MS).
3. ℓ indicates dimension when using with a preset screw.
4. See P.485 for standard Tightening Torque.

Boquilla Collet Pág. 090-093	Llave Inglesa Spanner Pág. 099	Tornillo de preajuste Preset screw Pág. 098	Llave Allen Adjustment wrench Pág. 099	Ejemplo para Ordenar - Ordering Example		
				ST1250	- HDZ	12
				Interfaz y diámetro de husillo		Máx. Diámetro Interno de boquilla
				Shank size		Longitud de proyección
						Max. collet I.D.
						Projection length (L)



ST-ERC

Collet Holder For Small Diameters

- Apropriado para mecanizar en un espacio angosto.
- Suitable for machining in tight space.

Tipo 1 Type1

Tornillo de preajuste

Portaherramienta ERC8: se vende por separado
Portaherramienta con diámetro mayor a 8: incluido

Preset Screw

ERC8 Holder : Sold separately
Other Holder : Included

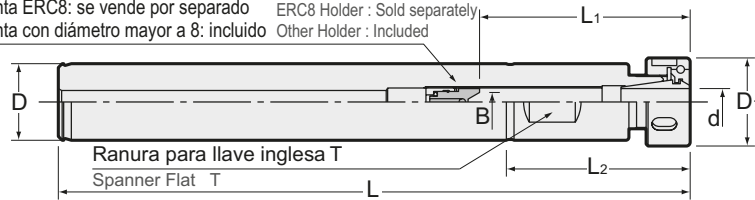

Tipo 2 Type2

Tornillo de preajuste

Portaherramienta ERC8: se vende por separado
Portaherramienta con diámetro mayor a 8: incluido

Preset Screw
ERC8 Holder : Sold separately
Other Holder : Included

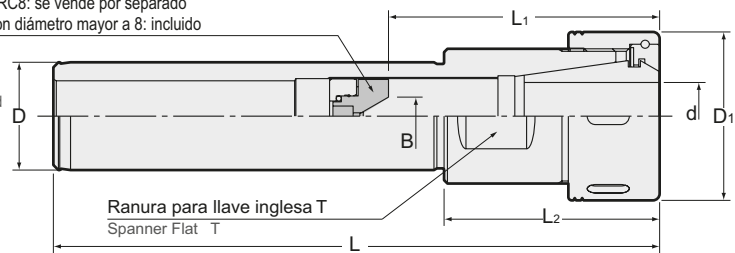

Medidas Métricas - Metric Sizes (Zanco - Shank)

Unidad : Métrico
Unit : Metric

Código Code	Modelo Model	Tipo Type	d	L	B	L1	L2	D _{0.012}	D1	T	Tornillo de Preajuste Preset Screw	Tuerca ciega Nut	kg	Boquilla Collet	Llave Inglesa Spanner
0410 01208075	ST12 -ERC8* -75	1	0.5~5.0	75	— (0~2.4)	34 (19~31)	32	12	12	10	—	ERP-8	0.05		
0410 01208105	-105	1	0.5~5.0	105	— (0~2.4)	34 (19~31)	32	12	12	10	—	ERP-8	0.07	ER8	S-8E
0410 01208135	-135	1	0.5~5.0	135	— (0~2.4)	34 (19~31)	32	12	12	10	—	ERP-8	0.1		
0410 01610105	ST16 -ERC11S -105	1	0.5~7.0	105	0~4.0	22~45	35	16	16	14	HDS07A-ES11	ERP-11S	0.2		
0410 01610135	-135	1	0.5~7.0	135	0~4.0	22~45	35	16	16	14	HDS07A-ES11	ERP-11S	0.2	ER11	S-11E
0410 01610165	-165	1	0.5~7.0	165	0~4.0	22~45	35	16	16	14	HDS07A-ES11	ERP-11S	0.2		
0410 02011165	ST20 ERC11 -165	1	0.5~7.0	165	0~4.0	22~42	48	20	23	17	HDS07A-ES11	HDP-07A	0.4	ER11	S-0
0410 02016165	ST20 ERC16 -165	2	0.5~10.0	165	0~5.0	33~54	51	20	32	19	ES16	ERP-16	0.4	ER16	FK-0030
0410 03225180	ST32 ERC25 -180	1	0.5~16.0	180	0~8.0	43~80	59	32	42	29	HDS16A-ES25	ERP-25		ER25	HS-1-16
0410 03232180	ST32 ERC32 -180	2	2.0~20.0	180	0~10.0	50~101	64	32	50	36	HDS22A-ES32	ERP-32		ER32	HS-2-20

1. La boquilla y la llave inglesa se venden por separado.
2. *El ES8, un tornillo de preajuste para el ERC8, se vende por separado. El ERC11S incluye un tornillo estándar de preajuste HDS-07A-ES11.
3. Las dimensiones "B" e "L1" sirven para usar el tornillo de preajuste ES8.
4. Consulte la pág. 088 para conocer la longitud mínima para insertar herramientas en caso de usar nuestras boquillas refrigerantes.
5. Consulte la pág. 485 para conocer el Torque recomendado para nuestros productos.

1. Collet and spanner are sold separately.
2. *ES8, a preset screw for ERC8, is sold separately. ERC11S includes a standard preset screw HDS-07A-ES11.
3. " B " and " L1 " dimensions in brackets are for using ES8 preset screw.
4. Refer to P. 088 for minimum tool insertion length in case of using our coolant collets.
5. See P.485 for standard Tightening Torque.

Ejemplo para Ordenar - Ordering Example

ST12 - ERC 8 - 105

Interfaz y diámetro de husillo

Shank size

Máx. Diámetro Interno de boquilla

Max. collet I.D.

Longitud de proyección

Projection length (L)

Medida en Pulgadas - Inch Sizes (Zanco - Shank)

Unidad : Pulgadas
Unit : Inch

Código Code	Modelo Model	Tipo Type	d	L	B	L1	L2	D ₀ ⁰ _{-0.0005}	D1	T	Tornillo de Preajuste Preset Screw	Tuerca ciega Nut	kg	Boquilla Collet	Llave Inglesa Spanner
0410 12411165	ST0750 ERC11 -165	1	0.020~0.276	6.496	0.0~0.157	0.866~1.654	1.890	0.750	0.906	0.669 (17mm)	HDS07A-ES11	HDP-07A	0.3	ER11	S-0
0410 12416165	ST0750 ERC16 -165	2	0.020~0.394	6.496	0.0~0.197	1.299~2.126	2.008	0.750	1.260	0.748 (19mm)	ES16	ERP-16		ER16	FK-0030
0410 14025180	ST1250 ERC25 -180	1	0.020~0.630	7.087	0.0~0.315	1.693~3.150	2.323	1.250	1.654	1.142 (29mm)	HDS16A-ES25	ERP-25		ER25	HS-1-16
0410 14032180	ST1250 ERC32 -180	2	0.079~0.787	7.087	0.0~0.394	1.969~3.976	2.520	1.250	1.969	1.417 (36mm)	HDS22A-ES32	ERP-32		ER32	HS-2-20

1. La boquilla y la llave inglesa se venden por separado.
2. *El ES8, un tornillo de preajuste para el ERC8, se vende por separado. El ERC11S incluye un tornillo preajuste HDS-07A-ES11.
3. Las dimensiones "B" e "I" sirven para usar el tornillo de preajuste ES8.
4. Consulte la pág. 088 para conocer la longitud mínima para insertar herramientas en caso de usar nuestras boquillas refrigerantes.
5. Consulte la pág. 485 para conocer el Torque recomendado para nuestros productos.

1. Collet and spanner are sold separately.
2. *ES8, a preset screw for ERC8, is sold separately. ERC11S includes a standard preset screw HDS-07A-ES11.
3. "B" and "L1" dimensions in brackets are for using ES8 preset screw.
4. Refer to P. 088 for minimum tool insertion length in case of using our coolant collets.
5. See P.485 for standard Tightening Torque.

Ejemplo para Ordenar - Ordering Example

ST0750 - ERC 11 - 105

Interfaz y diámetro de husillo

Shank size

Máx. Diámetro Interno de boquilla
Max. collet I.D.

Longitud de proyección

Projection length (L)

Boquilla Collet
Pág. 094-095



Llave Inglesa Spanner
Pág. 099



Tornillo de preajuste Preset screw
Pág. 098



High-Precision Collet

BT	Diámetro del zanco de la herramienta Tool shank dia.		Modelo - Model					Diámetro del zanco de la herramienta Tool Shank dia.	Modelo Model FDC-32
	mm (métrico - metric)	pulgada - inch	FDC-07	FDC-09	FDC-12	FDC-16	FDC-22		
CAT	φ 1.0 ~ 0.5	φ 0.039 ~ 0.020	FDC-01007	—	—	—	—	φ20.0~20.5	FDC-20532
AHO	φ 1.5 ~ 1.0	φ 0.059 ~ 0.039	FDC-01507	—	—	—	—	φ20.5~21.0	FDC-21032
HSK-A/E/F/C	φ 2.0 ~ 1.5	φ 0.079 ~ 0.059	FDC-02007	—	—	—	—	φ21.0~21.5	FDC-21532
HSK-T	φ 2.5 ~ 2.0	φ 0.098 ~ 0.079	FDC-02507	—	—	—	—	φ21.5~22.0	FDC-22032
C	φ 3.0 ~ 2.5	φ 0.118 ~ 0.098	FDC-03007	FDC-03009	FDC-03012	—	—	φ22.0~22.5	FDC-22532
UTS	φ 3.5 ~ 3.0 (1/8")	φ 0.138 ~ 0.118	FDC-03507	FDC-03509	FDC-03512	—	—	φ22.5~23.0	FDC-23032
Máquinas Especializadas Specialized Machine	φ 4.0 ~ 3.5	φ 0.157 ~ 0.138	FDC-04007	FDC-04009	FDC-04012	FDC-04016	FDC-04022	φ23.0~23.5	FDC-23532
Equipo Relacionado Related Equipment	φ 4.5 ~ 4.0	φ 0.177 ~ 0.157	FDC-04507	FDC-04509	FDC-04512	FDC-04516	FDC-04522	φ23.5~24.0	FDC-24032
Taladro de Biselado & Casquillo Bush & Chamfering Drill	φ 5.0 ~ 4.5 (3/16")	φ 0.197 ~ 0.177	FDC-05007	FDC-05009	FDC-05012	FDC-05016	FDC-05022	φ24.0~24.5	FDC-24532
	φ 5.5 ~ 5.0	φ 0.217 ~ 0.197	FDC-05507	FDC-05509	FDC-05512	FDC-05516	FDC-05522	φ24.5~25.0	FDC-25032
	φ 6.0 ~ 5.5	φ 0.236 ~ 0.217	FDC-06007	FDC-06009	FDC-06012	FDC-06016	FDC-06022	φ25.0~25.5	FDC-25532
	φ 6.5 ~ 6.0 (1/4")	φ 0.256 ~ 0.236	FDC-06507	FDC-06509	FDC-06512	FDC-06516	FDC-06522	φ25.5~26.0	FDC-26032
	φ 7.0 ~ 6.5	φ 0.276 ~ 0.256	FDC-07007	FDC-07009	FDC-07012	FDC-07016	FDC-07022	φ26.0~26.5	FDC-26532
	φ 7.5 ~ 7.0	φ 0.295 ~ 0.276	—	FDC-07509	FDC-07512	FDC-07516	FDC-07522	φ26.5~27.0	FDC-27032
Milling Chuck	φ 8.0 ~ 7.5 (5/16")	φ 0.315 ~ 0.295	—	FDC-08009	FDC-08012	FDC-08016	FDC-08022	φ27.0~27.5	FDC-27532
	φ 8.5 ~ 8.0	φ 0.335 ~ 0.315	—	FDC-08509	FDC-08512	FDC-08516	FDC-08522	φ27.5~28.0	FDC-28032
	φ 9.0 ~ 8.5	φ 0.354 ~ 0.335	—	FDC-09009	FDC-09012	FDC-09016	FDC-09022	φ28.0~28.5	FDC-28532
	φ 9.5 ~ 9.0	φ 0.374 ~ 0.354	—	—	FDC-09512	FDC-09516	FDC-09522	φ28.5~29.0	FDC-29032
Collet Holder	φ 10.0 ~ 9.5 (3/8")	φ 0.394 ~ 0.374	—	—	FDC-10012	FDC-10016	FDC-10022	φ29.0~29.5	FDC-29532
	φ 10.5 ~ 10.0	φ 0.413 ~ 0.394	—	—	FDC-10512	FDC-10516	FDC-10522	φ29.5~30.0	FDC-30032
	φ 11.0 ~ 10.5	φ 0.433 ~ 0.413	—	—	FDC-11012	FDC-11016	FDC-11022	φ30.0~30.5	FDC-30532
	φ 11.5 ~ 11.0 (7/16")	φ 0.453 ~ 0.433	—	—	FDC-11512	FDC-11516	FDC-11522	φ30.5~31.0	FDC-31032
"R" Zero Holder	φ 12.0 ~ 11.5	φ 0.472 ~ 0.453	—	—	FDC-12012	FDC-12016	FDC-12022	φ31.0~31.5	FDC-31532
	φ 12.5 ~ 12.0	φ 0.492 ~ 0.472	—	—	—	FDC-12516	FDC-12522	φ31.5~32.0	FDC-32032
	φ 13.0 ~ 12.5 (1/2")	φ 0.512 ~ 0.492	—	—	—	FDC-13016	FDC-13022	Precisión Accuracy (4xd) A (10µm) B (15µm)	
	φ 13.5 ~ 13.0	φ 0.531 ~ 0.512	—	—	—	FDC-13016	FDC-13522		
Hydraulic Chuck	φ 14.0 ~ 13.5	φ 0.551 ~ 0.531	—	—	—	FDC-14016	FDC-14022		
	φ 14.5 ~ 14.0	φ 0.571 ~ 0.551	—	—	—	FDC-14016	FDC-14522		
	φ 15.0 ~ 14.5	φ 0.591 ~ 0.571	—	—	—	FDC-15016	FDC-15022		
	φ 15.5 ~ 15.0	φ 0.610 ~ 0.591	—	—	—	FDC-15516	FDC-15522		
Shrink Fit	φ 16.0 ~ 15.5 (5/8")	φ 0.630 ~ 0.610	—	—	—	FDC-16016	FDC-16022		
	φ 16.5 ~ 16.0	φ 0.650 ~ 0.630	—	—	—	—	FDC-16522		
	φ 17.0 ~ 16.5	φ 0.669 ~ 0.650	—	—	—	—	FDC-17022		
	φ 17.5 ~ 17.0	φ 0.689 ~ 0.669	—	—	—	—	FDC-17522		
Tapping Chuck	φ 18.0 ~ 17.5	φ 0.709 ~ 0.689	—	—	—	—	FDC-18022		
	φ 18.5 ~ 18.0	φ 0.728 ~ 0.709	—	—	—	—	FDC-18522		
	φ 19.0 ~ 18.5	φ 0.748 ~ 0.728	—	—	—	—	FDC-19022		
	φ 19.5 ~ 19.0 (3/4")	φ 0.768 ~ 0.748	—	—	—	—	FDC-19522		
Arbors	φ 20.0 ~ 19.5	φ 0.787 ~ 0.768	—	—	—	—	FDC-20022		
	φ 20.5 ~ 20.0	φ 0.807 ~ 0.787	—	—	—	—	FDC-20522		
	φ 21.0 ~ 20.5	φ 0.827 ~ 0.807	—	—	—	—	FDC-21022		
	φ 21.5 ~ 21.0	φ 0.846 ~ 0.827	—	—	—	—	FDC-21522		
Function Holder	φ 22.0 ~ 21.5	φ 0.866 ~ 0.846	—	—	—	—	FDC-22022		
	Precisión Accuracy (4xd)	AA (5µm)							
Turning Tool		A (10µm)							

Ejemplo de selección de la boquilla Selection example of collet

Para sujetar el zanco de herramienta φ10.0, hay 2 boquillas, φ10.0 y φ10.5.

Sugerimos que elija la boquilla φ10.0 para una mayor precisión.

Las boquillas AA se reducen en rangos de 0.5 mm.

To clamp φ10.0 tool shank, there are 2 collets, φ10.0 and φ10.5 collets.

We suggest you select φ10.0 collet for higher accuracy.

AA Collets collapse by 0.5mm.

Ejemplo para Ordenar - Ordering Example

FDC - 060 12 AA

Diá. Máximo de fresado Series 12 Precisión

Max. chucking dia. 12 Series Accuracy

FDC-OH

High-Precision Collet (For Tool With Coolant Hole)

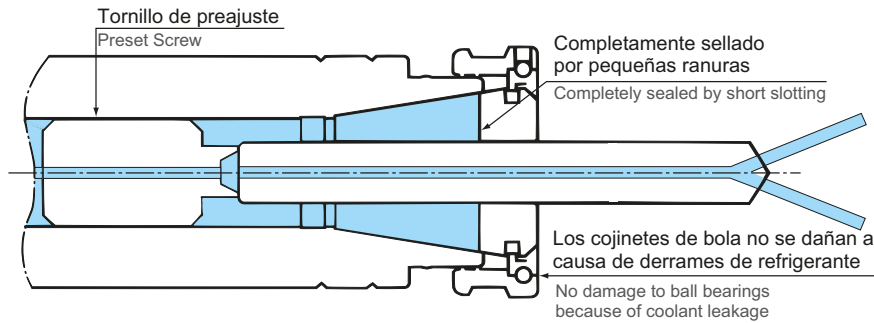

Diámetro del zanco de la herramienta / Tool shank dia.		Modelo - Model				
mm (inch)	inch	FDC-07-OHAA	FDC-09-OHAA	FDC-12-OHAA	FDC-16-OHAA	FDC-22-OHAA
φ 3.0	φ 0.118	FDC-03007-OHAA	FDC-03009-OHAA	FDC-03012-OHAA	-	-
φ 3.2 (1/8")	φ 0.125	FDC-03207-OHAA	FDC-03209-OHAA	FDC-03212-OHAA	-	-
φ 3.5	φ 0.138	FDC-03507-OHAA	FDC-03509-OHAA	FDC-03512-OHAA	-	-
φ 4.0	φ 0.157	FDC-04007-OHAA	FDC-04009-OHAA	FDC-04012-OHAA	-	-
φ 4.2	φ 0.165	FDC-04207-OHAA	FDC-04209-OHAA	FDC-04212-OHAA	-	-
φ 4.5	φ 0.177	FDC-04507-OHAA	FDC-04509-OHAA	FDC-04512-OHAA	-	-
φ 4.8 (3/16")	φ 0.187	FDC-04807-OHAA	FDC-04809-OHAA	FDC-04812-OHAA	-	-
φ 5.0	φ 0.197	FDC-05007-OHAA	FDC-05009-OHAA	FDC-05012-OHAA	-	-
φ 5.5	φ 0.217	FDC-05507-OHAA	FDC-05509-OHAA	FDC-05512-OHAA	-	-
φ 6.0	φ 0.236	FDC-06007-OHAA	FDC-06009-OHAA	FDC-06012-OHAA	FDC-06016-OHAA	FDC-06022-OHAA
φ 6.4 (1/4")	φ 0.250	FDC-06407-OHAA	FDC-06409-OHAA	FDC-06412-OHAA	FDC-06416-OHAA	FDC-06422-OHAA
φ 6.5	φ 0.256	FDC-06507-OHAA	FDC-06509-OHAA	FDC-06512-OHAA	FDC-06516-OHAA	FDC-06522-OHAA
φ 6.8	φ 0.268	FDC-06807-OHAA	FDC-06809-OHAA	FDC-06812-OHAA	FDC-06816-OHAA	FDC-06822-OHAA
φ 7.0	φ 0.276	FDC-07007-OHAA	FDC-07009-OHAA	FDC-07012-OHAA	FDC-07016-OHAA	FDC-07022-OHAA
φ 7.5	φ 0.295	-	FDC-07509-OHAA	FDC-07512-OHAA	FDC-07516-OHAA	FDC-07522-OHAA
φ 8.0 (5/16")	φ 0.315	-	FDC-08009-OHAA	FDC-08012-OHAA	FDC-08016-OHAA	FDC-08022-OHAA
φ 8.5	φ 0.335	-	FDC-08509-OHAA	FDC-08512-OHAA	FDC-08516-OHAA	FDC-08522-OHAA
φ 9.0	φ 0.354	-	FDC-09009-OHAA	FDC-09012-OHAA	FDC-09016-OHAA	FDC-09022-OHAA
φ 9.5	φ 0.374	-	-	FDC-09512-OHAA	FDC-09516-OHAA	FDC-09522-OHAA
φ 9.6 (3/8")	φ 0.375	-	-	FDC-09612-OHAA	FDC-09616-OHAA	FDC-09622-OHAA
φ 10.0	φ 0.394	-	-	FDC-10012-OHAA	FDC-10016-OHAA	FDC-10022-OHAA
φ 10.2	φ 0.402	-	-	FDC-10212-OHAA	FDC-10216-OHAA	FDC-10222-OHAA
φ 10.5	φ 0.413	-	-	FDC-10512-OHAA	FDC-10516-OHAA	FDC-10522-OHAA
φ 11.0	φ 0.433	-	-	FDC-11012-OHAA	FDC-11016-OHAA	FDC-11022-OHAA
φ 11.2 (7/16")	φ 0.437	-	-	FDC-11212-OHAA	FDC-11216-OHAA	FDC-11222-OHAA
φ 11.5	φ 0.453	-	-	FDC-11512-OHAA	FDC-11516-OHAA	FDC-11522-OHAA
φ 12.0	φ 0.472	-	-	FDC-12012-OHAA	FDC-12016-OHAA	FDC-12022-OHAA
φ 12.5	-	-	-	-	FDC-12516-OHAA	FDC-12522-OHAA
φ 12.7 (1/2")	φ 0.500	-	-	-	FDC-12716-OHAA	FDC-12722-OHAA
φ 13.0	φ 0.512	-	-	-	FDC-13016-OHAA	FDC-13022-OHAA
φ 13.5	-	-	-	-	FDC-13516-OHAA	FDC-13522-OHAA
φ 14.0	-	-	-	-	FDC-14016-OHAA	FDC-14022-OHAA
φ 14.5	-	-	-	-	FDC-14516-OHAA	FDC-14522-OHAA
φ 15.0	-	-	-	-	FDC-15016-OHAA	FDC-15022-OHAA
φ 15.5	-	-	-	-	FDC-15516-OHAA	FDC-15522-OHAA
φ 16.0 (5/8")	φ 0.630	-	-	-	FDC-16016-OHAA	FDC-16022-OHAA
φ 16.5	-	-	-	-	-	FDC-16522-OHAA
φ 17.0	-	-	-	-	-	FDC-17022-OHAA
φ 17.5	-	-	-	-	-	FDC-17522-OHAA
φ 18.0	φ 0.709	-	-	-	-	FDC-18022-OHAA
φ 18.5	-	-	-	-	-	FDC-18522-OHAA
φ 19.0	-	-	-	-	-	FDC-19022-OHAA
φ 19.1 (3/4")	φ 0.750	-	-	-	-	FDC-19122-OHAA
φ 19.5	-	-	-	-	-	FDC-19522-OHAA
φ 20.0	φ 0.787	-	-	-	-	FDC-20022-OHAA
φ 20.5	-	-	-	-	-	FDC-20522-OHAA
φ 21.0	-	-	-	-	-	FDC-21022-OHAA
φ 21.5	-	-	-	-	-	FDC-21522-OHAA
φ 22.0	φ 0.866	-	-	-	-	FDC-22022-OHAA

- Las boquillas de refrigerante OHAA se reducen en rangos de 0.1 mm.
- Las medidas de boquilla que no se enlistaron previamente sólo están disponibles bajo pedido.

- OHAA Coolant collets collapse by 0.1mm.
- Collet sizes not listed above are available upon request.

Precisión Accuracy (4×d)	AA (5µm)
	A (10µm)

Ejemplo para Ordenar - Ordering Example

FDC - 060 12 - OH AA
 Diá. Máximo de fresado / Max. chucking dia. Series 12 Precisión / Accuracy

FDC-C

High-Precision Collet (For Collet Through)

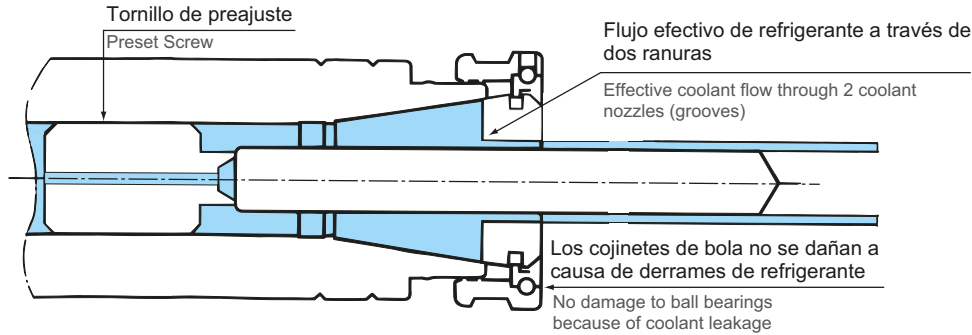

	Diámetro del zanco de herramientas Tool shank dia.	Modelo - Model				
		FDC-07-C φ3 ~φ7 (mm) φ0.118 ~φ0.276 (inch)	FDC-09-C φ3 ~φ9 (mm) φ0.118 ~φ0.354 (inch)	FDC-12-C φ3 ~φ12 (mm) φ0.118 ~φ0.472 (inch)	FDC-16-C φ6 ~φ16 (mm) φ0.236 ~φ0.630 (inch)	FDC-22-C φ6 ~φ22 (mm) φ0.236 ~φ0.866 (inch)
Milling Chuck						
Collet Holder	φ 3.0 (mm) φ 0.118 (inch)	FDC-03007-C	FDC-03009-C	FDC-03012-C	FDC-06016-C	FDC-06022-C
"R" Zero Holder		En incrementos de 0.1 mm In 0.1mm increments	En incrementos de 0.1 mm In 0.1mm increments	En incrementos de 0.1 mm In 0.1mm increments		
Hydraulic Chuck	En incrementos de 0.1 mm In 0.1mm increments	FDC-07007-C	FDC-09009-C	FDC-12012-C	En incrementos de 0.1 mm In 0.1mm increments	En incrementos de 0.1 mm In 0.1mm increments
Shrink Fit						
Tapping Chuck					FDC-16016-C	
Arbors	φ 22.0 (mm) φ 0.866 (inch)					FDC-22022-C

Las boquillas de refrigerante CAA se reducen en rangos de 0.1 mm.

CAA Coolant collets collapse by 0.1mm.

Precisión Accuracy (4×d)	AA (5μm)
	A (10μm)

Ejemplo para Ordenar - Ordering Example

FDC - 060	12 - C	AA
Diá. Máximo de fresado Max. chucking dia.	Series 12 12 Series	Precisión Accuracy

FDC-MS

High-Precision Collet (For Semidry Machining /MQL)

- Hace que el lubricante se adhiera a la superficie de la pieza de trabajo y de la herramienta al rociar partículas comparativamente grandes junto a la herramienta.
- Making lubricant adhere to the surface of workpiece and tool by spraying comparatively large particles alongside the tool.

Rocío de alta velocidad
High-speed mist

Ranura rociadora de aceite
Oil mist ejecting nozzle

Cuando está seco, cosas más pequeñas a 2 micrómetros difícilmente se pueden adherir a la superficie.
Dry smaller than 2 micrometers can hardly adhere to the surface.

Alargar las partículas
Al reducir el paso del rocío, la densidad del rocío aumenta. Eventualmente, las partículas pequeñas se pegan unas con otras para hacerse más grandes.
Enlarge the particles
By decreasing the passage of mist, the density of mist will become higher. Eventually, small particles collide each other to grow into larger ones.

El tamaño de las partículas del rocío deben hacerse más pequeñas para garantizar su movimiento fluido con el aire. (La pérdida en el transporte puede reducirse en caso de usar un rocío seco que sea menos pegajoso)
Mist particle size should be made smaller to ensure smooth movement with air. (Transportation loss can be minimized in the case of less sticky dry fog)

Lubricando los bordes laterales de la herramienta
Lubricating side edges of tool

Sin derrame por las ranuras
No leakage from slits

Ranura de aerosol
Jet spray nozzle

La forma de la ranura se calculó cuidadosamente conforme al diámetro de cada herramienta.
Elaborately calculated nozzle shape for individual tool diameter

Diámetro del zanco de la herramienta Tool shank dia.	Modelo - Model				
	FDC-07-MS	FDC-09-MS	FDC-12-MS	FDC-16-MS	FDC-22-MS
φ 3.0	FDC-03007-MS	FDC-03009-MS	FDC-03012-MS	—	—
φ 4.0	FDC-04007-MS	FDC-04009-MS	FDC-04012-MS	—	—
φ 5.0	FDC-05007-MS	FDC-05009-MS	FDC-05012-MS	—	—
φ 6.0	—	FDC-06009-MS	FDC-06012-MS	FDC-06016-MS	FDC-06022-MS
φ 7.0	—	FDC-07009-MS	FDC-07012-MS	FDC-07016-MS	FDC-07022-MS
φ 8.0	—	FDC-08009-MS	FDC-08012-MS	FDC-08016-MS	FDC-08022-MS
φ 9.0	—	—	FDC-09012-MS	FDC-09016-MS	FDC-09022-MS
φ 10.0	—	—	FDC-10012-MS	FDC-10016-MS	FDC-10022-MS
φ 11.0	—	—	FDC-11012-MS	FDC-11016-MS	FDC-11022-MS
φ 12.0	—	—	FDC-12012-MS	FDC-12016-MS	FDC-12022-MS
φ 13.0	—	—	—	FDC-13016-MS	FDC-13022-MS
φ 14.0	—	—	—	FDC-14016-MS	FDC-14022-MS
φ 16.0	—	—	—	—	FDC-16022-MS
φ 20.0	—	—	—	—	FDC-20022-MS

1. Las boquillas MSAA se reducen en rangos de 0.1 mm.
2. Las medidas que no se enlistaron previamente sólo están disponibles bajo pedido
3. Se pueden usar herramientas con o sin vena de lubricación.
4. Las medidas en pulgadas están disponibles.

1. MSAA Collets collapse by 0.1mm.
2. Sizes not listed above are available upon request.
3. Tools with or without coolant holes can be used.
4. Inch sizes are available.

Precisión Accuracy (4×d)	AA (5µm)
	A (10µm)

Ejemplo para Ordenar - Ordering Example

FDC - 060 12 MS AA

Diá. Máximo de fresado Series 12 Precisión
Max. chucking dia. 12 Series Accuracy

Collet For Small Diameters

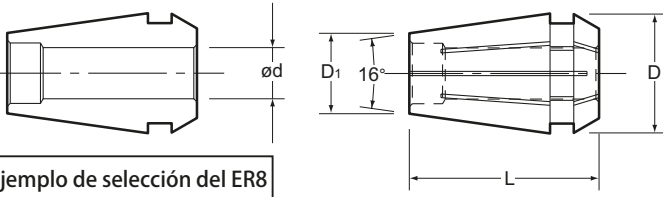

Ejemplo de selección del ER8

Selection example of ER8

Ejemplo para Ordenar - Ordering Example

ER8 - 2.0 AA

Diá. Máximo de
fresado
Max. chucking dia.

Precisión
Accuracy

Para sujetar el zanco de herramienta $\phi 3.0$, hay 2 boquillas, $\phi 3.0$ y $\phi 3.5$.

Sugerimos que elija la boquilla $\phi 3.0$ para una mayor precisión.

To clamp $\phi 3.0$ tool shank, there are 2 collets, $\phi 3.0$ and $\phi 3.5$ collets. We suggest you select $\phi 3.0$ collet for higher accuracy.

Datos sobre la dimensión de la boquilla ER

ER collet dimensional data

Tipo Type	D	D1	L	Diámetro Interno (I.D.)	
				pulgadas - inch	mm
ER8	0.331	0.217	0.535	ϕ 0.020-0.197	ϕ 0.5-5.0
ER11	0.406	0.307	0.709	ϕ 0.020-0.276	ϕ 0.5-7.0
ER16	0.677	0.445	1.063	ϕ 0.020-0.394	ϕ 0.5-10.0
ER20	0.835	0.571	1.220	ϕ 0.020-0.512	ϕ 0.5-13.0
ER25	1.031	0.728	1.378	ϕ 0.020-0.630	ϕ 0.5-16.0
ER32	1.307	0.961	1.575	ϕ 0.098-0.787	ϕ 2.5-20.0
ER40	1.622	1.228	1.811	ϕ 0.118-1.024	ϕ 3.0-26.0
ER50	2.067	1.539	2.362	ϕ 0.394-1.339	ϕ 10.0-34.0

AA esta disponible

AA is available.

I.D.	Tipo - Type		ER8 AA	ER11 AA	ER16 A	ER20 A	ER25 A	ER32 A	ER40 A	ER50 A
	mm	pulgadas - inch								
ϕ 1.0 - 0.5	ϕ 0.039 - 0.020		ER8-1.0	ER11-1.0	ER16-1.0	ER20-1.0	ER25-1.0			
ϕ 1.5 - 1.0	ϕ 0.059 - 0.039		ER8-1.5	ER11-1.5	ER16-1.5	ER20-1.5	ER25-1.5			
ϕ 2.0 - 1.5	ϕ 0.079 - 0.059		ER8-2.0	ER11-2.0	ER16-2.0	ER20-2.0	ER25-2.0			
ϕ 2.5 - 2.0	ϕ 0.098 - 0.079		ER8-2.5	ER11-2.5	ER16-2.5	ER20-2.5	ER25-2.5			
ϕ 3.0 - 2.5	ϕ 0.118 - 0.098		ER8-3.0	ER11-3.0	ER16-3.0	ER20-3.0	ER25-3.0	ER32-3.0		
ϕ 3.5 - 3.0 (1/8")	ϕ 0.138 - 0.118		ER8-3.5	ER11-3.5	ER16-3.5	ER20-3.5	ER25-3.5	ER32-3.5		
ϕ 4.0 - 3.5	ϕ 0.157 - 0.138		ER8-4.0	ER11-4.0	ER16-4.0					
ϕ 4.5 - 4.0	ϕ 0.177 - 0.157		ER8-4.5	ER11-4.5	ER16-4.5					
ϕ 5.0 - 4.5 (3/16")	ϕ 0.197 - 0.177		ER8-5.0	ER11-5.0	ER16-5.0					
ϕ 5.5 - 5.0	ϕ 0.217 - 0.197			ER11-5.5	ER16-5.5					
ϕ 6.0 - 5.5	ϕ 0.236 - 0.217			ER11-6.0	ER16-6.0					
ϕ 6.5 - 6.0 (1/4")	ϕ 0.256 - 0.236			ER11-6.5	ER16-6.5					
ϕ 7.0 - 6.5	ϕ 0.276 - 0.256			ER11-7.0	ER16-7.0					
ϕ 7.5 - 7.0	ϕ 0.295 - 0.276				ER16-7.5					
ϕ 8.0 - 7.5 (5/16")	ϕ 0.315 - 0.295				ER16-8.0					
ϕ 8.5 - 8.0	ϕ 0.335 - 0.315				ER16-8.5					
ϕ 9.0 - 8.5	ϕ 0.354 - 0.335				ER16-9.0					
ϕ 9.5 - 9.0	ϕ 0.374 - 0.354				ER16-9.5					
ϕ 10.0 - 9.5 (3/8")	ϕ 0.394 - 0.374				ER16-10.0					
ϕ 4.0 - 3.0	ϕ 0.157 - 0.118					ER20-4.0	ER25-4.0	ER32-4.0	ER40-4.0	
ϕ 5.0 - 4.0 (3/16")	ϕ 0.197 - 0.157					ER20-5.0	ER25-5.0	ER32-5.0	ER40-5.0	
ϕ 6.0 - 5.0	ϕ 0.236 - 0.197					ER20-6.0	ER25-6.0	ER32-6.0	ER40-6.0	
ϕ 7.0 - 6.0 (1/4")	ϕ 0.276 - 0.236					ER20-7.0	ER25-7.0	ER32-7.0	ER40-7.0	
ϕ 8.0 - 7.0 (5/16")	ϕ 0.315 - 0.276					ER20-8.0	ER25-8.0	ER32-8.0	ER40-8.0	
ϕ 9.0 - 8.0	ϕ 0.354 - 0.315					ER20-9.0	ER25-9.0	ER32-9.0	ER40-9.0	
ϕ 10.0 - 9.0 (3/8")	ϕ 0.394 - 0.354					ER20-10.0	ER25-10.0	ER32-10.0	ER40-10.0	
ϕ 11.0 - 10.0	ϕ 0.433 - 0.394					ER20-11.0	ER25-11.0	ER32-11.0	ER40-11.0	ER50-12.0
ϕ 12.0 - 11.0	ϕ 0.472 - 0.433					ER20-12.0	ER25-12.0	ER32-12.0	ER40-12.0	
ϕ 13.0 - 12.0 (1/2")	ϕ 0.512 - 0.472					ER20-13.0	ER25-13.0	ER32-13.0	ER40-13.0	ER50-14.0
ϕ 14.0 - 13.0	ϕ 0.551 - 0.512						ER25-14.0	ER32-14.0	ER40-14.0	
ϕ 15.0 - 14.0	ϕ 0.591 - 0.551						ER25-15.0	ER32-15.0	ER40-15.0	ER50-16.0
ϕ 16.0 - 15.0 (5/8")	ϕ 0.630 - 0.591						ER25-16.0	ER32-16.0	ER40-16.0	
ϕ 17.0 - 16.0	ϕ 0.669 - 0.630							ER32-17.0	ER40-17.0	ER50-18.0
ϕ 18.0 - 17.0	ϕ 0.709 - 0.669							ER32-18.0	ER40-18.0	
ϕ 19.0 - 18.0	ϕ 0.748 - 0.709							ER32-19.0	ER40-19.0	ER50-20.0
ϕ 20.0 - 19.0 (3/4")	ϕ 0.787 - 0.748							ER32-20.0	ER40-20.0	
ϕ 21.0 - 20.0	ϕ 0.827 - 0.787								ER40-21.0	ER50-22.0
ϕ 22.0 - 21.0	ϕ 0.866 - 0.827								ER40-22.0	
ϕ 23.0 - 22.0 (7/8")	ϕ 0.906 - 0.866								ER40-23.0	ER50-24.0
ϕ 24.0 - 23.0	ϕ 0.945 - 0.906								ER40-24.0	
ϕ 25.0 - 24.0	ϕ 0.984 - 0.945								ER40-25.0	ER50-26.0
ϕ 26.0 - 25.0 (1")	ϕ 1.024 - 0.984								ER40-26.0	
ϕ 27.0 - 26.0	ϕ 1.063 - 1.024									ER50-28.0
ϕ 28.0 - 27.0	ϕ 1.102 - 1.063									
ϕ 29.0 - 28.0	ϕ 1.142 - 1.102									ER50-30.0
ϕ 30.0 - 29.0	ϕ 1.181 - 1.142									
ϕ 31.0 - 30.0	ϕ 1.220 - 1.181									ER50-32.0
ϕ 32.0 - 31.0 (1-1/4")	ϕ 1.260 - 1.220									
ϕ 33.0 - 32.0	ϕ 1.299 - 1.260									ER50-34.0
ϕ 34.0 - 33.0	ϕ 1.339 - 1.299									

Pulgada a métrico → Pulgada × 25.4

Métrico a pulgada → Métrico ÷ 25.4 ó métrico por 0.03937



Tamaños especiales / personalizados bajo pedido

Rango de reducción de la boquilla ER - ER collet collapse range

Tipo Type	Diámetro Interno I.D.	Rango de reducción Collapse Range		Tipo Type	Diámetro Interno I.D.	Rango de reducción Collapse Range		Tipo Type	Diámetro Interno I.D.	Rango de reducción Collapse Range	
ER8	1.0 - 5.0mm	0.020"	0.5mm	ER20	1.0 - 3.5mm	0.020"	0.5mm	ER32	3.0 - 3.5mm	0.020"	0.5mm
ER11	1.0 - 7.0mm	0.020"	0.5mm		4.0 - 13.0mm	0.039"	1.0mm		4.0 - 20.0mm	0.039"	1.0mm
ER16	1.0 - 10.0mm	0.020"	0.5mm	ER25	1.0 - 3.5mm	0.020"	0.5mm	ER40	4.0 - 26.0mm	0.039"	1.0mm
					4.0 - 16.0mm	0.039"	1.0mm		ER50	12.0 - 34.0mm	0.079"

ER-OH

Para una herramienta con vena de lubricación

For tool with coolant hole

Diámetro del zanco de herramientas Tool shank dia.		Modelo ER8-OH
mm	pulgadas - inch	Medida - Size
φ 1.8	φ 0.071	ER8-1.8-OH
φ 1.9	φ 0.075	ER8-1.9-OH
φ 2.0	φ 0.079	ER8-2.0-OH
φ 2.1	φ 0.083	ER8-2.1-OH
φ 2.2	φ 0.087	ER8-2.2-OH
φ 2.3	φ 0.091	ER8-2.3-OH
φ 2.4	φ 0.094	ER8-2.4-OH
φ 2.5	φ 0.098	ER8-2.5-OH
φ 2.6	φ 0.102	ER8-2.6-OH
φ 2.7	φ 0.106	ER8-2.7-OH
φ 2.8	φ 0.110	ER8-2.8-OH
φ 2.9	φ 0.114	ER8-2.9-OH
φ 3.0	φ 0.118	ER8-3.0-OH
φ 3.1	φ 0.122	ER8-3.1-OH
φ 3.2	φ 0.126	ER8-3.2-OH
φ 3.3	φ 0.130	ER8-3.3-OH
φ 3.4	φ 0.134	ER8-3.4-OH
φ 3.5	φ 0.138	ER8-3.5-OH
φ 3.6	φ 0.142	ER8-3.6-OH
φ 3.7	φ 0.146	ER8-3.7-OH
φ 3.8	φ 0.150	ER8-3.8-OH
φ 3.9	φ 0.154	ER8-3.9-OH
φ 4.0	φ 0.157	ER8-4.0-OH
φ 4.1	φ 0.161	ER8-4.1-OH
φ 4.2	φ 0.165	ER8-4.2-OH
φ 4.3	φ 0.169	ER8-4.3-OH
φ 4.4	φ 0.173	ER8-4.4-OH
φ 4.5	φ 0.177	ER8-4.5-OH
φ 4.6	φ 0.181	ER8-4.6-OH
φ 4.7	φ 0.185	ER8-4.7-OH
φ 4.8	φ 0.189	ER8-4.8-OH
φ 4.9	φ 0.193	ER8-4.9-OH
φ 5.0	φ 0.197	ER8-5.0-OH

Límite de reducción de la boquilla de refrigerante ER8-OH: 0.1mm. Shrinkage allowance for coolant collet ER8-OH : 0.1mm

Diámetro del zanco de herramientas Tool shank dia.		Modelo ER11-OH
mm	pulgadas - inch	Medida - Size
φ 3.0	φ 0.118	ER11-3.0-OH
φ 3.2 (1/8")	φ 0.125	ER11-3.2-OH
φ 3.5	φ 0.138	ER11-3.5-OH
φ 4.0	φ 0.157	ER11-4.0-OH
φ 4.2	φ 0.165	ER11-4.2-OH
φ 4.5	φ 0.177	ER11-4.5-OH
φ 4.8 (3/16")	φ 0.187	ER11-4.8-OH
φ 5.0	φ 0.197	ER11-5.0-OH
φ 5.5	φ 0.217	ER11-5.5-OH
φ 6.0	φ 0.236	ER11-6.0-OH
φ 6.4 (1/4")	φ 0.250	ER11-6.4-OH
φ 6.5	φ 0.256	ER11-6.5-OH
φ 6.8	φ 0.268	ER11-6.8-OH
φ 7.0	φ 0.276	ER11-7.0-OH

Favor de contactar a NT TOOL MEX. para las boquillas con refrigerante ER16-ER50. Please contact NT TOOL MEX. for ER16 - ER50 coolant type.

Ejemplo para Ordenar - Ordering Example

ER8 - 2.0 -OH AA
 Diá. Máximo de fresado / Max. chucking dia. Precisión / Accuracy

ER-C

Para refrigerante por costados de la boquilla

For Collet through

Diámetro del zanco de herramientas Tool shank dia.		Modelo ER8-C
mm	pulgadas - inch	Medida - Size
φ 1.8	φ 0.071	ER8-1.8-C
φ 1.9	φ 0.075	ER8-1.9-C
φ 2.0	φ 0.079	ER8-2.0-C
φ 2.1	φ 0.083	ER8-2.1-C
φ 2.2	φ 0.087	ER8-2.2-C
φ 2.3	φ 0.091	ER8-2.3-C
φ 2.4	φ 0.094	ER8-2.4-C
φ 2.5	φ 0.098	ER8-2.5-C
φ 2.6	φ 0.102	ER8-2.6-C
φ 2.7	φ 0.106	ER8-2.7-C
φ 2.8	φ 0.110	ER8-2.8-C
φ 2.9	φ 0.114	ER8-2.9-C
φ 3.0	φ 0.118	ER8-3.0-C
φ 3.1	φ 0.122	ER8-3.1-C
φ 3.2	φ 0.126	ER8-3.2-C
φ 3.3	φ 0.130	ER8-3.3-C
φ 3.4	φ 0.134	ER8-3.4-C
φ 3.5	φ 0.138	ER8-3.5-C
φ 3.6	φ 0.142	ER8-3.6-C
φ 3.7	φ 0.146	ER8-3.7-C
φ 3.8	φ 0.150	ER8-3.8-C
φ 3.9	φ 0.154	ER8-3.9-C
φ 4.0	φ 0.157	ER8-4.0-C
φ 4.1	φ 0.161	ER8-4.1-C
φ 4.2	φ 0.165	ER8-4.2-C
φ 4.3	φ 0.169	ER8-4.3-C
φ 4.4	φ 0.173	ER8-4.4-C
φ 4.5	φ 0.177	ER8-4.5-C
φ 4.6	φ 0.181	ER8-4.6-C
φ 4.7	φ 0.185	ER8-4.7-C
φ 4.8	φ 0.189	ER8-4.8-C
φ 4.9	φ 0.193	ER8-4.9-C
φ 5.0	φ 0.197	ER8-5.0-C

Límite de reducción de la boquilla de refrigerante ER8-OH: 0.1mm. Shrinkage allowance for coolant collet ER8-C : 0.1mm

Diámetro del zanco de herramientas Tool shank dia.		Modelo ER11-C
mm	pulgadas - inch	Medida - Size
φ 3.0	φ 0.118	ER11-3.0-C
φ 3.2 (1/8")	φ 0.125	ER11-3.2-C
φ 3.5	φ 0.138	ER11-3.5-C
φ 4.0	φ 0.157	ER11-4.0-C
φ 4.2	φ 0.165	ER11-4.2-C
φ 4.5	φ 0.177	ER11-4.5-C
φ 4.8 (3/16")	φ 0.187	ER11-4.8-C
φ 5.0	φ 0.197	ER11-5.0-C
φ 5.5	φ 0.217	ER11-5.5-C
φ 6.0	φ 0.236	ER11-6.0-C
φ 6.4 (1/4")	φ 0.250	ER11-6.4-C
φ 6.5	φ 0.256	ER11-6.5-C
φ 6.8	φ 0.268	ER11-6.8-C
φ 7.0	φ 0.276	ER11-7.0-C

Favor de contactar a NT TOOL MEX. para las boquillas con refrigerante ER16-ER50. Please contact NT TOOL MEX. for ER16 - ER50 coolant type.

Ejemplo para Ordenar - Ordering Example

ER8 - 2.0 -C AA
 Diá. Máximo de fresado / Max. chucking dia. Precisión / Accuracy

Longitud mínima de inserción de herramienta cuando se utiliza una boquilla de refrigerante y una herramienta con espiga.

Minimum tool insertion length when coolant collet and tool with tang are used.

HDC-A, GDC-A, ERC, ERC-T, HDZ, GDZ, ERZ

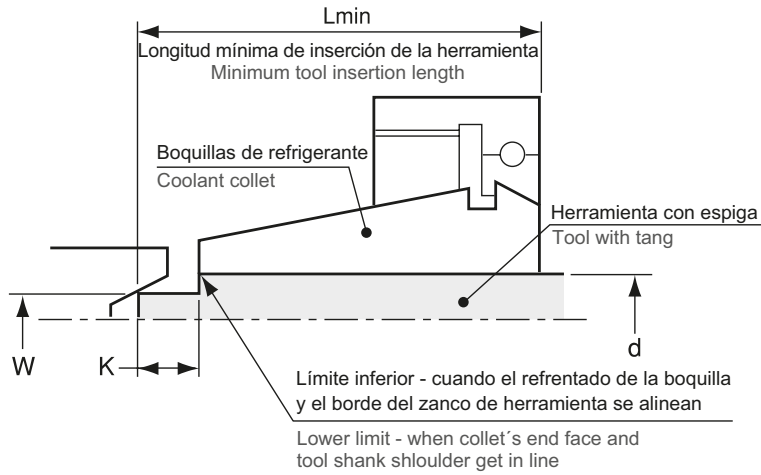

Unidad : Métrico
Unit : Metric

Medida de boquilla Collet size (OH,C,MS)	Diámetro de sujeción Chucking diameter	Geometría de la herramienta de corte - Geometry of cutting tool												
		Diámetro del zanco de la herramienta Tool shank dia.	ø3.1~5.0		ø5.1~6.0		ø6.1~9.0		ø9.1~12.0		ø12.1~16.0		ø16.1~22.0	
		Grosor de la espiga Tang width	2.4		3		4		5		6		8	
		Longitud de la espiga Tang length	5	3	6	3	8	5	8	5	10	5	12	5
ER8	ø1.8~5.0	L valor mín cuando se use la herramienta con espiga L min value when using tool with tang	20.5	19	-	-	-	-	-	-	-	-	-	-
ER11	ø3.0~7.0		23	22	24	22	26	23	-	-	-	-	-	-
FDC07	ø3.0~7.0		23	22	24	22	26	23	-	-	-	-	-	-
FDC09	ø3.0~9.0		28	27	29	27	31	28	-	-	-	-	-	-
FDC12	ø3.0~12.0		33	33	33.5	33	35.5	33	35.5	33	-	-	-	-
FDC16	ø6.0~16.0		-	-	38.5	38	40.5	38	40.5	38	42.5	38	-	-
FDC22	ø6.0~22.0		-	-	47	47	47.5	47	47.5	47	49.5	47	51.5	47

- 1.El bisel de la espiga en la herramienta NO se toma en consideración para nada.
- 2.Habrà derrame de refrigerante si no se mantiene la longitud mínima de inserción.
- 3.La longitud mínima de inserción variará según la longitud de la espiga (K).

- 1.Chamfer at tool tang is NOT taken into account at all.
- 2.Coolant leakage will happen if minimum insertion length is not kept.
- 3.Minimum insertion length will vary according to tang length(K).

Dimensión para la boquilla y la tuerca ciega

Dimension for Collet and Nut

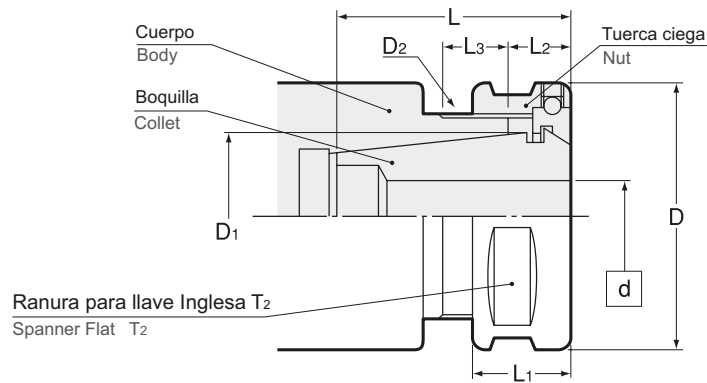

Unidad : Métrico
Unit : Metric

Modelo Model	Tuerca ciega Nut	Llave Inglesa Spanner	d	D	D1	D2	L	L1	L2	L3 MIN	T2
FDC - d 07	HDP-07A	S-0	0.5~7.0	23	10.9	M14 P=0.75	18.0	11.5	6.5	9	-
FDC - d 09	HDP-09	S-1L	2.5~9.0	26	13.57	M19 P=1	23.0	13.0	8.0	9	24
FDC - d 12	HDP-12	S-3L	2.5~12.0	32	18.42	M24 P=1	27.5	14.0	8.5	9	30
FDC - d 16	HDP-16	S-4L	3.5~16.0	36	22.2	M28 P=1	32.5	14.0	9.0	9	33
FDC - d 22	HDP-22	S-5L	3.5~22.0	46	30.6	M36 P=1	39.5	16.0	10.0	9	42

Dimensiones para el cuerpo

Dimension for body

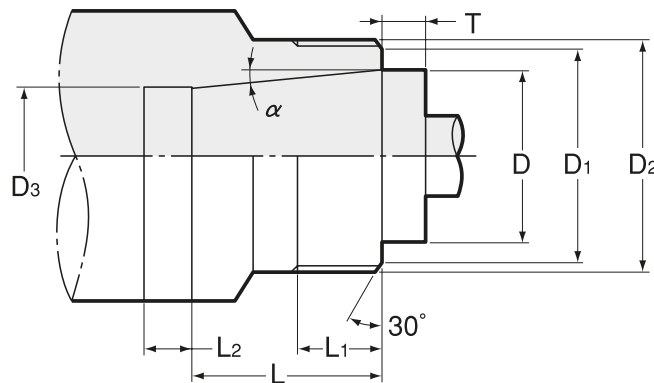

Unidad : Métrico
Unit : Metric

Modelo Model	Tuerca ciega Nut	D	T±0.1	D1	D2	(D3)	L	L1 MIN	(L2)	α
FDC - d 07	HDP-07A	10.9	4	13	M14 P=0.75	8.5	10	9.0	6	8°
FDC - d 09	HDP-09	13.57	5	17	M19 P=1	10.5	17	9.0	4	5°59'
FDC - d 12	HDP-12	18.42	5	22	M24 P=1	14.5	21	9.0	4	5°59'
FDC - d 16	HDP-16	22.2	5	26	M28 P=1	17.5	25	9.0	4	5°59'
FDC - d 22	HDP-22	30.6	5	34	M36 P=1	24.0	35	10	4	5°59'

D3 y L2 son únicamente como referencia y pueden modificarse a su diseño. Contáctenos para conocer el calibrador de zanco.
D3 and L2 are for reference only and can be changed to your design. Contact us for taper gauge.

HDS, ES

Preset Screw

HDC-A, GDC-A, HDZ, GDZ

Unidad : Métrico
Unit : Metric

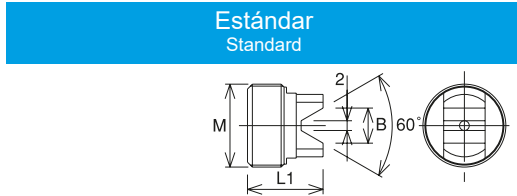

Código Code	Modelo Model	B	M	L1	Medida de portaherramienta Holder size
2545 00000007	HDS-07	5.5	M8 P=1	14	07
2545 00000009	HDS-09	5.5	M10 P=1	14	09
2545 00000012	HDS-12	7.2	M14 P=1	15.5	12
2545 00000016	HDS-16	7.2	M17 P=1	15.5	16
2545 00000022	HDS-22	9.5	M23 P=1	17.5	22

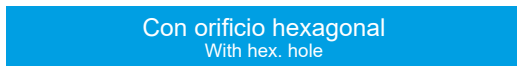

Tipo 1
Type 1

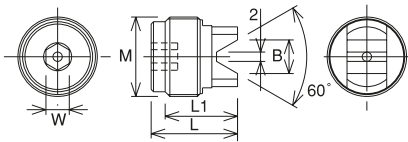

Unidad : Métrico
Unit : Metric

Código Code	Modelo Model	Tipo Type	W	B	ød	M	L	L1	Medida de portaherramienta Holder size
2545 30000007	HDS-07-3	1	3	5.5	-	M8 P=1	17	14	07
2545 40000007	HDS-07-4	1	4	5.5	-	M8 P=1	17	14	07
2545 30000009	HDS-09-3	1	3	5.5	-	M10 P=1	17	14	09
2545 40000009	HDS-09-4	1	4	5.5	-	M10 P=1	17	14	09
2545 50000009	HDS-09-5	1	5	5.5	-	M10 P=1	17	14	09
2545 30000012	HDS-12-3	1	3	7.2	-	M14 P=1	18.5	15.5	12
2545 40000012	HDS-12-4	1	4	7.2	-	M14 P=1	18.5	15.5	12
2545 50000012	HDS-12-5	1	5	7.2	-	M14 P=1	18.5	15.5	12
2545 30000016	HDS-16-3	1	3	7.2	-	M17 P=1	18.5	15.5	16
2545 40000016	HDS-16-4	1	4	7.2	-	M17 P=1	18.5	15.5	16
2545 50000016	HDS-16-5	1	5	7.2	-	M17 P=1	18.5	15.5	16
2545 30000022	HDS-22-3	1	3	9.5	-	M23 P=1	20.5	17.5	22
2545 40000022	HDS-22-4	1	4	9.5	-	M23 P=1	20.5	17.5	22
2545 50000022	HDS-22-5	1	5	9.5	-	M23 P=1	20.5	17.5	22
2545 31000007	HDS-07-3C *	2	3	-	6	M8 P=1	17	14	07
2545 41000007	HDS-07-4C *	2	4	-	6	M8 P=1	17	14	07
2545 31000009	HDS-09-3C	2	3	-	8	M10 P=1	17	14	09
2545 41000009	HDS-09-4C	2	4	-	8	M10 P=1	17	14	09
2545 51000009	HDS-09-5C	2	5	-	8	M10 P=1	17	14	09
2545 31000012	HDS-12-3C	2	3	-	12	M14 P=1	18.5	15.5	12
2545 41000012	HDS-12-4C	2	4	-	12	M14 P=1	18.5	15.5	12
2545 51000012	HDS-12-5C	2	5	-	12	M14 P=1	18.5	15.5	12
2545 31000016	HDS-16-3C	2	3	-	15	M17 P=1	18.5	15.5	16
2545 41000016	HDS-16-4C	2	4	-	15	M17 P=1	18.5	15.5	16
2545 51000016	HDS-16-5C	2	5	-	15	M17 P=1	18.5	15.5	16
2545 31000022	HDS-22-3C	2	3	-	21	M23 P=1	20.5	17.5	22
2545 41000022	HDS-22-4C	2	4	-	21	M23 P=1	20.5	17.5	22
2545 51000022	HDS-22-5C	2	5	-	21	M23 P=1	20.5	17.5	22

Tipo 2
Type 2

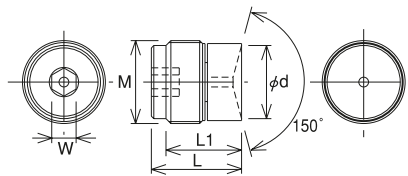

- En caso de utilizar una fresa con modelos que tengan * y sean menores de $\phi 2$, no aplicará la función de ajuste longitudinal debido a que la fresa va colocada en el orificio de refrigerante.
- El rango máximo de ajuste puede diferir del correspondiente al tornillo estándar de preajuste.

- In case using drill less than $\phi 2$ for models with *, length adjustment function does not work since drill goes into coolant hole.
- Max. adjustment range can be different from standard preset screw.

Para mecanizado semiseco
For semi-dry machining

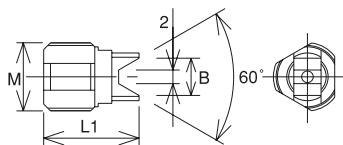

Unidad : Métrico
Unit : Metric

Código Code	Modelo Model	L	B	D	M	Medida de portaherramienta Holder size
3164 00000007	HDS-07-MS	14	5.5	7	M8 P=1	7
3164 00000009	HDS-09-MS	14	5.5	7	M10 P=1	9
3164 00000012	HDS-12-MS	15.5	7.2	12.8	M14 P=1	12
3164 00000016	HDS-16-MS	15.5	7.2	12.8	M17 P=1	16
3164 00000022	HDS-22-MS	17.5	9.5	18	M23 P=1	22

- Para herramienta de corte con o sin orificio de refrigerante.
 - No aplica para herramientas de corte con menos de $\phi 3$ en el diámetro del vástago.
- For cutting tool with or without oil hole.
 - Not applicable for cutting tools with less than $\phi 3$ shank diameter.

ERC, ERC-T, ERZ

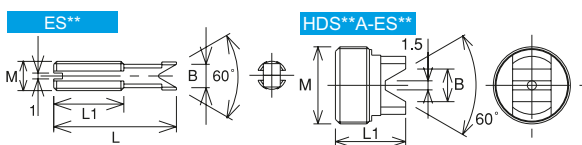

Código Code	Modelo Model	B	M	L	L1	Medida de portaherramienta Holder size
2555 00000008	ES8	4	M5 P=0.8	21	12	ERC8
2555 00070011	HDS-07A-ES11	5.5	M8 P=1	—	14.5	ERC11S, ERC11
2555 00000016	ES16	9.8	M11 P=1	—	14.5	ERC16
2555 00120020	HDS12A-ES20	12.8	M14 P=1	—	16	ERC20
2555 00160025	HDS16A-ES25	15.8	M17 P=1	—	16	ERC25
2555 00220032	HDS22A-ES32	20	M23 P=1	—	18	ERC32
2555 00000040	ES40	24	M31 P=1	—	21.5	ERC40
2555 00000050	ES50	26	M36 P=1	—	23	ERC50

Pulgada a métrico → Pulgada × 25.4
Métrico a pulgada → Métrico ÷ 25.4 ó métrico por 0.03937



Tamaños especiales / personalizados bajo pedido

Combinación de accesorios

Accessories combination

HDC-A, HDZ, SDM, KH-E

Boquilla - Collet		Tuerca ciega - Nut		Llave Inglesa - Spanner	
Modelo - Model	Código - Code	Modelo - Model	Código - Code	Modelo - Model	Código - Code
FDC-07	—	HDP-07A	0070 03001407	S-0	0803 00000000
FDC-09	—	HDP-09	2544 00000009	S-1L	0803 00000011
FDC-12	—	HDP-12	2544 00000012	S-3L	0803 00000013
FDC-16	—	HDP-16	2544 00000016	S-4L	0803 00000014
FDC-22	—	HDP-22	2544 00000022	S-5L	0803 00000015
FDC-32	—	HDP-32	0070 00105648	S-6	0803 00000006

Llave Inglesa S-** Spanner



Llave Inglesa S-0, S-6 Spanner



GDC-A, GDZ

Boquilla - Collet		Tuerca ciega - Nut		Llave Inglesa - Spanner	
Modelo - Model	Código - Code	Modelo - Model	Código - Code	Modelo - Model	Código - Code
FDC-07AA	—	HDP-07A	0070 03001407	S-0	0803 00000000
FDC-09AA	—	GDP-09	2444 00000009	S-0	0803 00000000
FDC-12AA	—	GDP-12	2444 00000012	FK-0034	2445 00000034
FDC-16AA	—	GDP-16	2444 00000016	FK-0034	2445 00000034
FDC-22AA	—	GDP-22	2444 00000022	FK-0045	2445 00000045

Llave Inglesa S-0, FK-00** Spanner



ERC, ERC-T, ERZ

Boquilla - Collet		Tuerca ciega - Nut		Llave Inglesa - Spanner	
Modelo - Model	Código - Code	Modelo - Model	Código - Code	Modelo - Model	Código - Code
ER8	—	ERP-8	2554 00000008	S-8E	0803 00000007
ER11	—	ERP-11S	2554 00000010	S-11E	0803 00000008
ER11	—	HDP-07A	0070 03001407	S-0	0803 00000000
ER16	—	ERP-16	2554 00000016	FK-0034	2445 00000034
ER20	—	ERP-20	2554 00000020	FK-0034	2445 00000034
ER25	—	ERP-25	2554 00000025	HS-1-16	0711 00001016
ER32	—	ERP-32	2554 00000032	HS-2-20	0711 00002020
ER40	—	ERP-40	2554 00000040	HS-2.5-25	0711 00002525
ER50	—	ERP-50	2554 00000050	HS-4-42	0711 00004042

Llave Inglesa S-** Spanner



Llave Inglesa S-0, FK-00** Spanner HS-*** Spanner



Llave Allen - Hex. Wrench

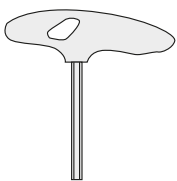

Modelo - Model	Código - Code
L-3T	6080 00000030
L-4T	6080 00115576
L-5T	6080 00115577
L-6T	6080 00115578

Cabeza de llave Inglesa / Llave allen Spanner Head / Torque Wrench

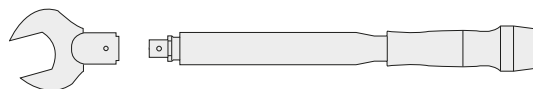

Consulte la pág. 485 para conocer sobre la Cabeza de llave de torque / Llave allen
See P.485 for Spanner Head / Torque wrench.

Inserción y remoción de la boquilla Collet insertion and removal

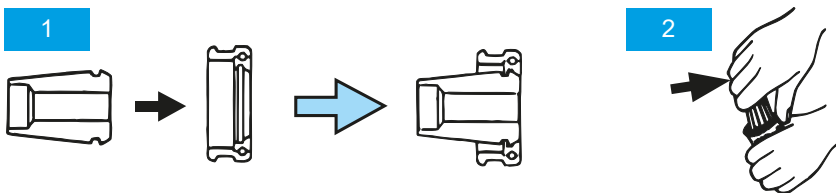

- Para sujetar
Coloque la boquilla FDC en el extremo roscado de la tuerca ciega HDP. Presione hacia abajo en la parte trasera de la boquilla para que haga "clic" la boquilla con la tuerca ciega.
 - Para remover
Mientras sostiene firmemente con una mano la tuerca ciega HDP, sujete la boquilla FDC con la otra mano mientras empuja hacia un costado.
- To attach
Place FDC collet into threaded end of HDP nut. Press down on rear of the collet to "clip" the collet into the nut.
 - To remove
While holding HDP nut firmly in one hand grasp FDC collet in the other while pushing sideways.

"R"Zero Holder

- La precisión del borde de corte puede ajustarse hasta casi cero.
- Runout accuracy of the cutting edge can be adjusted as closely as to zero.

Tipo 1 Type 1

Tornillos de ajuste de excentricidad
Runout adjustment screws

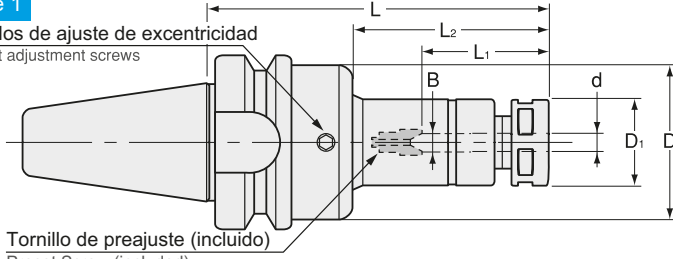

Tornillo de preajuste (incluido)
Preset Screw (included)

Tipo 2 Type 2

Tornillos de ajuste de excentricidad
Runout adjustment screws

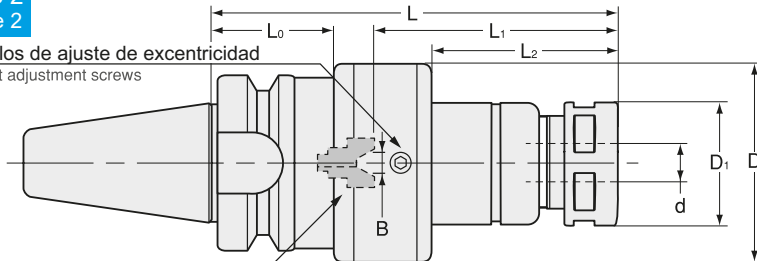

Tornillo de preajuste (incluido)
Preset Screw (included)







Unidad : Métrico
Unit : Metric

Código Code	Modelo Model	Tipo Type	d	L	L1	L2	B	D	D1	L0	Tuerca ciega Nut	kg	Boquilla Collet	Llave Inglesa Spanner	Llave Allen Hex.Wrench
3090 10706000	BT30 -HDZ07 -60	1	0.5 ~ 7.0	60	22 ~ 45	22	0 ~ 4	41	23	—	HDP-07A	0.6	FDC-07	S-0	L-3T
3090 10707500	-75	1	0.5 ~ 7.0	75	22 ~ 45	37	0 ~ 4	41	23	—	HDP-07A	0.6			
3090 10709000	-90	1	0.5 ~ 7.0	90	22 ~ 45	52	0 ~ 4	41	23	—	HDP-07A	0.7			
3090 10710500	-105	1	0.5 ~ 7.0	105	22 ~ 45	67	0 ~ 4	41	23	—	HDP-07A	0.7			
3090 10907500	BT30 -HDZ09 -75	1	2.5 ~ 9.0	75	27 ~ 57	37	0 ~ 4	45	26	—	HDP-09	0.7	FDC-09	S-1L	L-3T
3090 10909000	-90	1	2.5 ~ 9.0	90	27 ~ 57	52	0 ~ 4	45	26	—	HDP-09	0.7			
3090 10910500	-105	1	2.5 ~ 9.0	105	27 ~ 57	67	0 ~ 4	45	26	—	HDP-09	0.7			
3090 11209000	BT30 -HDZ12 -90	2	2.5 ~ 12.0	90	33 ~ 69	33	0 ~ 5	52	32	32	HDP-12	1.0	FDC-12	S-3L	L-4T
3090 11210500	-105	2	2.5 ~ 12.0	105	33 ~ 69	48	0 ~ 5	52	32	32	HDP-12	1.1			
3090 11609000	BT30 -HDZ16 -90	2	3.5 ~ 16.0	90	38 ~ 82	33	0 ~ 6	56	36	32	HDP-16	1.0	FDC-16	S-4L	L-4T
3090 11610500	-105	2	3.5 ~ 16.0	105	38 ~ 82	48	0 ~ 6	56	36	32	HDP-16	1.1			
3090 11612000	-120	2	3.5 ~ 16.0	120	38 ~ 82	63	0 ~ 6	56	36	32	HDP-16	1.1			
3090 30707500	BT40 -HDZ07 -75	1	0.5 ~ 7.0	75	22 ~ 45	32	0 ~ 4	41	23	—	HDP-07A	1.2	FDC-07	S-0	L-3T
3090 30709000	-90	1	0.5 ~ 7.0	90	22 ~ 45	47	0 ~ 4	41	23	—	HDP-07A	1.2			
3090 30710500	-105	1	0.5 ~ 7.0	105	22 ~ 45	62	0 ~ 4	41	23	—	HDP-07A	1.2			
3090 30909000	BT40 -HDZ09 -90	1	2.5 ~ 9.0	90	27 ~ 57	47	0 ~ 4	45	26	—	HDP-09	1.3	FDC-09	S-1L	L-3T
3090 30910500	-105	1	2.5 ~ 9.0	105	27 ~ 57	62	0 ~ 4	45	26	—	HDP-09	1.3			
3090 30912000	-120	1	2.5 ~ 9.0	120	27 ~ 57	77	0 ~ 4	45	26	—	HDP-09	1.3			
3090 30913500	-135	1	2.5 ~ 9.0	135	27 ~ 57	92	0 ~ 4	45	26	—	HDP-09	1.3			
3090 30916500	-165	1	2.5 ~ 9.0	165	27 ~ 57	122	0 ~ 4	45	26	—	HDP-09	1.3			
3090 31209000	BT40 -HDZ12 -90	1	2.5 ~ 12.0	90	33 ~ 69	43	0 ~ 5	56	32	—	HDP-12	1.5	FDC-12	S-3L	L-4T
3090 31210500	-105	1	2.5 ~ 12.0	105	33 ~ 69	58	0 ~ 5	56	32	—	HDP-12	1.6			
3090 31212000	-120	1	2.5 ~ 12.0	120	33 ~ 69	73	0 ~ 5	56	32	—	HDP-12	1.6			
3090 31213500	-135	1	2.5 ~ 12.0	135	33 ~ 69	88	0 ~ 5	56	32	—	HDP-12	1.7			
3090 31216500	-165	1	2.5 ~ 12.0	165	33 ~ 69	118	0 ~ 5	56	32	—	HDP-12	1.7			
3090 31219500	-195	1	2.5 ~ 12.0	195	33 ~ 69	148	0 ~ 5	56	32	—	HDP-12	2.0			
3090 31609000	BT40 -HDZ16 -90	1	3.5 ~ 16.0	90	38 ~ 82	43	0 ~ 6	62	36	—	HDP-16	1.6	FDC-16	S-4L	L-4T
3090 31610500	-105	1	3.5 ~ 16.0	105	38 ~ 82	58	0 ~ 6	62	36	—	HDP-16	1.7			
3090 31612000	-120	1	3.5 ~ 16.0	120	38 ~ 82	73	0 ~ 6	62	36	—	HDP-16	1.8			
3090 31613500	-135	1	3.5 ~ 16.0	135	38 ~ 82	88	0 ~ 6	62	36	—	HDP-16	1.9			
3090 31616500	-165	1	3.5 ~ 16.0	165	38 ~ 82	118	0 ~ 6	62	36	—	HDP-16	2.1			
3090 31619500	-195	1	3.5 ~ 16.0	195	38 ~ 82	148	0 ~ 6	62	36	—	HDP-16	2.1			

Código Code	Modelo Model	Tipo Type	d	L	L1	L2	B	D	D1	L0	Tuerca ciega Nut	kg	Boquilla Collet	Llave Inglesa Spanner	Llave Allen Hex. Wrench
3090 32210510	BT40 -HDZ22-A-105	2	3.5 ~ 22.0	105	47 ~ 103	31	0 ~ 8	69	46	45	HDP-22	2.1	FDC-22	S-5L	L-5T
3090 32212010	-120	2	3.5 ~ 22.0	120	47 ~ 103	46	0 ~ 8	69	46	45	HDP-22	2.3			
3090 32213510	-135	2	3.5 ~ 22.0	135	47 ~ 103	61	0 ~ 8	69	46	45	HDP-22	2.5			
3090 32216510	-165	2	3.5 ~ 22.0	165	47 ~ 103	91	0 ~ 8	69	46	45	HDP-22	2.8			
3090 32219510	-195	2	3.5 ~ 22.0	195	47 ~ 103	121	0 ~ 8	69	46	45	HDP-22				
3090 50709000	BT50 -HDZ07 -90	1	0.5 ~ 7.0	90	22 ~ 45	36	0 ~ 4	41	23	-	HDP-07	3.8	FDC-07A	S-0	L-3T
3090 50710500	-105	1	0.5 ~ 7.0	105	22 ~ 45	51	0 ~ 4	41	23	-	HDP-07				
3090 50712000	-120	1	0.5 ~ 7.0	120	22 ~ 45	66	0 ~ 4	41	23	-	HDP-07				
3090 50713500	-135	1	0.5 ~ 7.0	135	22 ~ 45	81	0 ~ 4	41	23	-	HDP-07				
3090 50716500	-165	1	0.5 ~ 7.0	165	22 ~ 45	111	0 ~ 4	41	23	-	HDP-07				
3090 50719500	-195	1	0.5 ~ 7.0	195	22 ~ 45	141	0 ~ 4	41	23	-	HDP-07				
3090 50909000	BT50 -HDZ09 -90	1	2.5 ~ 9.0	90	27 ~ 57	36	0 ~ 4	45	26	-	HDP-09		FDC-09	S-1L	L-3T
3090 50910500	-105	1	2.5 ~ 9.0	105	27 ~ 57	51	0 ~ 4	45	26	-	HDP-09	3.8			
3090 50912000	-120	1	2.5 ~ 9.0	120	27 ~ 57	66	0 ~ 4	45	26	-	HDP-09				
3090 50913500	-135	1	2.5 ~ 9.0	135	27 ~ 57	81	0 ~ 4	45	26	-	HDP-09				
3090 50916500	-165	1	2.5 ~ 9.0	165	27 ~ 57	111	0 ~ 4	45	26	-	HDP-09	4.1			
3090 50919500	-195	1	2.5 ~ 9.0	195	27 ~ 57	141	0 ~ 4	45	26	-	HDP-09				
3090 50922500	-225	1	2.5 ~ 9.0	225	27 ~ 57	171	0 ~ 4	45	26	-	HDP-09	4.3			
3090 50925500	-255	1	2.5 ~ 9.0	255	27 ~ 57	201	0 ~ 4	45	26	-	HDP-09	4.4			
3090 51209000	BT50 -HDZ12 -90	1	2.5 ~ 12.0	90	33 ~ 69	32	0 ~ 5	56	32	-	HDP-12	4.0	FDC-12	S-3L	L-4T
3090 51210500	-105	1	2.5 ~ 12.0	105	33 ~ 69	47	0 ~ 5	56	32	-	HDP-12				
3090 51212000	-120	1	2.5 ~ 12.0	120	33 ~ 69	62	0 ~ 5	56	32	-	HDP-12	4.1			
3090 51213500	-135	1	2.5 ~ 12.0	135	33 ~ 69	77	0 ~ 5	56	32	-	HDP-12				
3090 51216500	-165	1	2.5 ~ 12.0	165	33 ~ 69	107	0 ~ 5	56	32	-	HDP-12				
3090 51219500	-195	1	2.5 ~ 12.0	195	33 ~ 69	137	0 ~ 5	56	32	-	HDP-12				
3090 51222500	-225	1	2.5 ~ 12.0	225	33 ~ 69	167	0 ~ 5	56	32	-	HDP-12	4.6			
3090 51225500	-255	1	2.5 ~ 12.0	255	33 ~ 69	197	0 ~ 5	56	32	-	HDP-12	4.8			
3090 51609000	BT50 -HDZ16 -90	1	3.5 ~ 16.0	90	38 ~ 82	32	0 ~ 6	62	36	-	HDP-16	4.1	FDC-16	S-4L	L-4T
3090 51610500	-105	1	3.5 ~ 16.0	105	38 ~ 82	47	0 ~ 6	62	36	-	HDP-16	4.2			
3090 51612000	-120	1	3.5 ~ 16.0	120	38 ~ 82	62	0 ~ 6	62	36	-	HDP-16	4.3			
3090 51613500	-135	1	3.5 ~ 16.0	135	38 ~ 82	77	0 ~ 6	62	36	-	HDP-16	4.3			
3090 51616500	-165	1	3.5 ~ 16.0	165	38 ~ 82	107	0 ~ 6	62	36	-	HDP-16	4.5			
3090 51619500	-195	1	3.5 ~ 16.0	195	38 ~ 82	137	0 ~ 6	62	36	-	HDP-16	4.7			
3090 51622500	-225	1	3.5 ~ 16.0	225	38 ~ 82	167	0 ~ 6	62	36	-	HDP-16	4.9			
3090 51625500	-255	1	3.5 ~ 16.0	255	38 ~ 82	197	0 ~ 6	62	36	-	HDP-16	5.1			
3090 52210510	BT50 -HDZ22-A-105	1	3.5 ~ 22.0	105	47 ~ 103	43	0 ~ 8	76	46	-	HDP-22	4.5	FDC-22	S-5L	L-5T
3090 52212010	-120	1	3.5 ~ 22.0	120	47 ~ 103	58	0 ~ 8	76	46	-	HDP-22	4.6			
3090 52213510	-135	1	3.5 ~ 22.0	135	47 ~ 103	73	0 ~ 8	76	46	-	HDP-22	4.8			
3090 52215010	-150	1	3.5 ~ 22.0	150	47 ~ 103	88	0 ~ 8	76	46	-	HDP-22	5.0			
3090 52216510	-165	1	3.5 ~ 22.0	165	47 ~ 103	103	0 ~ 8	76	46	-	HDP-22	5.1			
3090 52219510	-195	1	3.5 ~ 22.0	195	47 ~ 103	133	0 ~ 8	76	46	-	HDP-22	5.4			
3090 52222510	-225	1	3.5 ~ 22.0	225	47 ~ 103	163	0 ~ 8	76	46	-	HDP-22	5.7			
3090 52225510	-255	1	3.5 ~ 22.0	255	47 ~ 103	193	0 ~ 8	76	46	-	HDP-22	6.0			

1. La boquilla, llave inglesa, tornillo Allen opresor de preajuste y el tornillo de preajuste para procesos semisecos se venden por separado. El tornillo estándar de preajuste está incluido.
2. Consulte la pág.088 para conocer la longitud mínima para insertar herramientas en caso de usar nuestras boquillas refrigerantes (OH, C o MS).
- 3.L1 indica la dimensión al usarlo con un tornillo de preajuste.
- 4.Consulte la pág.485 para conocer el Torque recomendado para nuestros productos.

1. Collet, spanner, hexagon head preset screw, preset screw for semi-dry processing, and hex. wrench are sold separately. Standard preset screw is included.
- 2.Refer to P. 088 for minimum tool insertion length in case of using our coolant collets (OH,C or MS).
- 3.L1 indicates dimension when using with a preset screw.
4. See P.485 for standard Tightening Torque.

Boquilla Collet Pág. 090-093	Llave Inglesa Spanner Pág. 099	Tornillo de preajuste Preset screw Pág. 098	Llave Allen Adjustment wrench Pág. 099
			

Ejemplo para Ordenar - Ordering Example

BT40	- HDZ	12	-	90
Interfaz y diámetro de husillo		Máx. Diámetro Interno de boquilla		Longitud de proyección
Shank size		Max. collet I.D.		Projection length (L)

CTZ-SA

"R"Zero Holder for Large Diameter

- La excentricidad del borde de corte se puede ajustar hasta casi cero. Es adecuado para rimado con diámetro amplio.
- Runout of the cutting edge can be adjusted as close as to zero. Suitable for large diameter reaming.

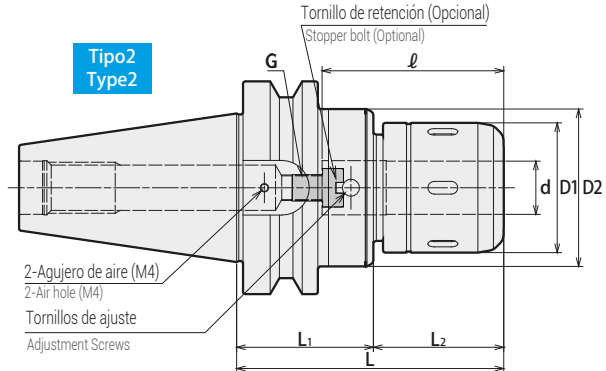
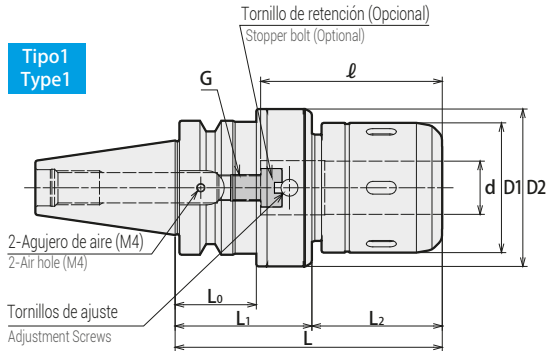

⚠ Precaución / Caution

- ★ Tenga precaución con la interferencia del brazo A.T.C. y el cartucho. Take caution against A.T.C. arm and tool magazine interference.

⚠ Precaución / Caution

Favor de girar el anillo de sujeción en sentido contrario a las manecillas del reloj por más de 360 grados después de remover una herramienta de corte. Please rotate the clamping ring counterclockwise more than 360 degrees after a cutting tool is removed.

Medidas Métricas - Metric Sizes

Unidad : Métrico
Unit : Metric

Código Code	Modelo Model	Tipo Type	d	L	L1	L2	D1	D2	L0	ℓ	G P=1.0	kg	Max. min ⁻¹	-	Llave Inglesa Spanner	Llave Allen Hex. Wrench
2950 40325125	BT40 -CTZ25SA -125	1	25	125	64	61	61	74	★ 38	80	12	2.9	16,000	48,500	HS-2.5-25	L-6L (Incluido - Included)
2950 40325150	-150	1	25	150	74	76	61	74	48	80	12	3.3	14,000	49,500		
2950 40332125	-CTZ32SA -125	1	32	125	64	61	68	80	★ 35	110	18	3.0	12,000	52,000	HS-3-32	
2950 40332150	-150	1	32	150	74	76	68	80	45	120	18	3.5	11,000	55,000		
2950 40525125	BT50 -CTZ25SA -125	2	25	125	64	61	61	74	—	80	12	5.2	14,000	57,300	HS-2.5-25	
2950 40525165	-165	2	25	165	64	101	61	74	—	80	12	5.7	12,000	60,000		
2950 40532125	-CTZ32SA -125	2	32	125	64	61	68	80	—	120	18	5.3	12,000	62,400	HS-3-32	
2950 40532165	-165	2	32	165	64	101	68	80	—	120	18	5.9	10,000	65,000		
2950 40542125	-CTZ42SA -125	2	42	125	64	61	88	99	—	120	18	6.2	10,000	67,500	HS-4-42	
2950 40542165	-165	2	42	165	64	101	88	99	—	120	18	7.5	10,000	70,000		

- Al hacer su orden, indique el número de llaves inglesas que requiere. Las llaves inglesas son "gratuitas" y están limitadas al número de portaherramientas de fresado de su orden.
- La llave Allen está incluida.
- Todos los accesorios, incluyendo las boquillas rectas, se pueden usar con los portaherramientas listados en la parte superior.
- Use dos piezas de tornillos Allen opresores (incluidos) M4 x 5 (S) para cerrar los orificios de aire en el portaherramienta cuando se use refrigerante interno.
- La tolerancia del zanco de la herramienta de corte debe estar dentro de h7.
- When ordering, indicate number of spanners required. "No charge" spanners are limited to number of holders on order.
- A wrench is included.
- All accessories including straight collets can be used with above holders.
- Use 2pcs. of M4 x 5 (S) hex. screw (included) to close air holes on the holder when internal coolant is used.
- Tolerance of cutting tool shank must be h7.

Ejemplo para Ordenar - Ordering Example

BT40 - CTZ 32 SA - 125

Interfaz y
diámetro de husillo
Shank size

Diámetro
Interno
I.D. (d)

Longitud de proyección
Projection length (L)

Llave Inglesa
Spanner

Pág. 073



Tornillo de Retención Stopper Bolt	Boquilla recta Straight Collet	Adaptador Morse Morse Taper Adapter	Adaptador Jacobs Jacobs Adapter
BL (Pág.072)	MC (Pág.070) MCA (Pág.071)	MA (Pág.072) MAB (Pág.072)	JA (Pág.073) JAB (Pág.073)

Longitud mín de inserción
Min. chucking length

Sujeción directa (sin boquilla MC)
Direct Chucking (without MC Collet)

Diámetro Interno del Portaherramienta I.D. of Chuck	Longitud mín de inserción Min. chucking length
25,32,42	50

Con boquilla MC
With MC collet

D.I. de la boquilla Collet I.D.	Longitud mín de inserción Min. chucking length	
	MC	MC-C, MC-OH
6,8	30	30
10,12	40	40
16,20	45	45
25	50	50
32	50	50

NOTAS

"R"Zero Holder (High-Balanced Type)

- La precisión de excentricidad del borde de corte puede ajustarse hasta casi cero. (El de tipo con alto balance es para RPM mayor)
- Runout accuracy of the cutting edge can be adjusted as closely as to zero. (High balanced type for higher RPM)

Tipo 1
Type1

Tornillo de preajuste (Se vende por separado)
Preset Screw (Sold Separately)

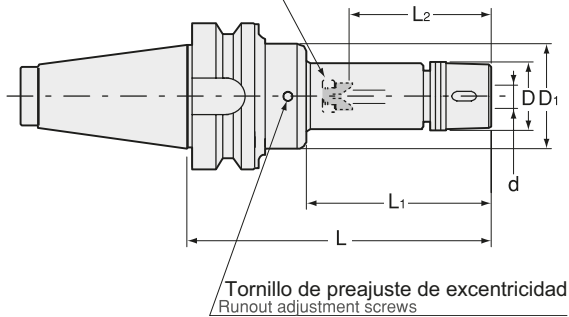
Tipo 2
Type2

Tornillo de preajuste (Se vende por separado)
Preset Screw (Sold Separately)

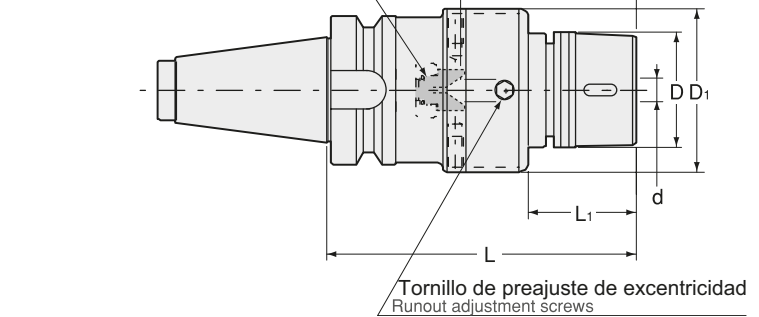

Unidad : Métrico
Unit : Metric





Código Code	Modelo Model	Tipo Type	d	L	L1	L2	D	D1	Tuerca ciega Nut	kg	Boquilla Collet	Llave Inglesa Spanner	Llave Allen Hex. Wrench
3120 00107060	BT30 -GDZ07 -60	1	0.5 ~ 7.0	60	22	22 ~ 45	23	41	HDP-07A	0.6	FDC-07AA	S-0	L-3T
3120 00107075	-75	1	0.5 ~ 7.0	75	37	22 ~ 45	23	41	HDP-07A	0.6			
3120 00107090	-90	1	0.5 ~ 7.0	90	52	22 ~ 45	23	41	HDP-07A	0.7			
3120 00107105	-105	1	0.5 ~ 7.0	105	67	22 ~ 45	23	41	HDP-07A	0.7			
3120 00109075	BT30 -GDZ09 -75	1	2.5 ~ 9.0	75	28	27 ~ 57	29	41	GDP-09	0.7	FDC-09AA	S-0	L-3T
3120 00109090	-90	1	2.5 ~ 9.0	90	43	27 ~ 57	29	41	GDP-09	0.7			
3120 00109105	-105	1	2.5 ~ 9.0	105	58	27 ~ 57	29	41	GDP-09	0.7			
3120 00112105	BT30 -GDZ12 -105	2	2.5 ~ 12.0	105	42	33 ~ 69	34	52	GDP-12	1.1	FDC-12AA	FK-0034	L-4T
3120 00112120	-120	2	2.5 ~ 12.0	120	57	33 ~ 69	34	52	GDP-12	1.1			
3120 00112135	-135	2	2.5 ~ 12.0	135	72	33 ~ 69	34	52	GDP-12	1.1			
3120 00116105	BT30 -GDZ16 -105	2	3.5 ~ 16.0	105	42	38 ~ 82	38	56	GDP-16	1.2	FDC-16AA	FK-0034	L-4T
3120 00116120	-120	2	3.5 ~ 16.0	120	57	38 ~ 82	38	56	GDP-16	1.2			
3120 00116135	-135	2	3.5 ~ 16.0	135	72	38 ~ 82	38	56	GDP-16	1.2			
3120 00307090	BT40 -GDZ07 -90	1	0.5 ~ 7.0	90	43	22 ~ 45	23	41	HDP-07A	1.3	FDC-07AA	S-0	L-3T
3120 00307105	-105	1	0.5 ~ 7.0	105	58	22 ~ 45	23	41	HDP-07A	1.3			
3120 00307120	-120	1	0.5 ~ 7.0	120	73	22 ~ 45	23	41	HDP-07A	1.3			
3120 00309090	BT40 -GDZ09 -90	1	2.5 ~ 9.0	90	43	27 ~ 57	29	45	GDP-09	1.3	FDC-09AA	S-0	L-3T
3120 00309105	-105	1	2.5 ~ 9.0	105	58	27 ~ 57	29	45	GDP-09	1.4			
3120 00309120	-120	1	2.5 ~ 9.0	120	73	27 ~ 57	29	45	GDP-09	1.4			
3120 00309135	-135	1	2.5 ~ 9.0	135	88	27 ~ 57	29	45	GDP-09	1.4			
3120 00309165	-165	1	2.5 ~ 9.0	165	118	27 ~ 57	29	45	GDP-09	1.4			
3120 00312090	BT40 -GDZ12 -90	1	2.5 ~ 12.0	90	39	33 ~ 69	34	56	GDP-12	1.5	FDC-12AA	FK-0034	L-4T
3120 00312105	-105	1	2.5 ~ 12.0	105	54	33 ~ 69	34	56	GDP-12	1.6			
3120 00312120	-120	1	2.5 ~ 12.0	120	69	33 ~ 69	34	56	GDP-12	1.7			
3120 00312135	-135	1	2.5 ~ 12.0	135	84	33 ~ 69	34	56	GDP-12	1.7			
3120 00312165	-165	1	2.5 ~ 12.0	165	114	33 ~ 69	34	56	GDP-12	1.7			
3120 00312195	-195	1	2.5 ~ 12.0	195	144	33 ~ 69	34	56	GDP-12	1.7			
3120 00316090	BT40 -GDZ16 -90	1	3.5 ~ 16.0	90	43	38 ~ 82	38	62	GDP-16	1.6	FDC-16AA	FK-0034	L-4T
3120 00316105	-105	1	3.5 ~ 16.0	105	58	38 ~ 82	38	62	GDP-16	1.7			
3120 00316120	-120	1	3.5 ~ 16.0	120	73	38 ~ 82	38	62	GDP-16	1.7			
3120 00316135	-135	1	3.5 ~ 16.0	135	88	38 ~ 82	38	62	GDP-16	1.7			
3120 00316165	-165	1	3.5 ~ 16.0	165	118	38 ~ 82	38	62	GDP-16	1.7			
3120 00316195	-195	1	3.5 ~ 16.0	195	148	38 ~ 82	38	62	GDP-16	1.7			
3120 00322120	BT40 -GDZ22 -120	2	3.5 ~ 22.0	120	40	47 ~ 103	49	69	GDP-22	2.4	FDC-22AA	FK-0045	L-5T
3120 00322135	-135	2	3.5 ~ 22.0	135	55	47 ~ 103	49	69	GDP-22	2.6			
3120 00322165	-165	2	3.5 ~ 22.0	165	85	47 ~ 103	49	69	GDP-22	2.6			
3120 00322195	-195	2	3.5 ~ 22.0	195	115	47 ~ 103	49	69	GDP-22	2.6			

Medidas Métricas - Metric Sizes

Unidad : Métrico
Unit : Metric

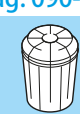
Código Code	Modelo Model	Tipo Type	d	L	L1	L2	D	D1	Tuerca ciega Nut	kg	Boquilla Collet	Llave Inglesa Spanner	Llave Allen Hex. Wrench
3120 00507090	BT50 -GDZ07 -90	1	0.5 ~ 7.0	90	32	22 ~ 45	23	41	HDP-07A		FDC-07AA	S-0	L-3T
3120 00507105	-105	1	0.5 ~ 7.0	105	47	22 ~ 45	23	41	HDP-07A	3.8			
3120 00507120	-120	1	0.5 ~ 7.0	120	62	22 ~ 45	23	41	HDP-07A				
3120 00507135	-135	1	0.5 ~ 7.0	135	77	22 ~ 45	23	41	HDP-07A				
3120 00507165	-165	1	0.5 ~ 7.0	165	107	22 ~ 45	23	41	HDP-07A				
3120 00507195	-195	1	0.5 ~ 7.0	195	137	22 ~ 45	23	41	HDP-07A				
3120 00509090	BT50 -GDZ09 -90	1	2.5 ~ 9.0	90	32	27 ~ 57	29	45	GDP-09		FDC-09AA	S-0	L-3T
3120 00509105	-105	1	2.5 ~ 9.0	105	47	27 ~ 57	29	45	GDP-09				
3120 00509120	-120	1	2.5 ~ 9.0	120	62	27 ~ 57	29	45	GDP-09				
3120 00509135	-135	1	2.5 ~ 9.0	135	77	27 ~ 57	29	45	GDP-09				
3120 00509165	-165	1	2.5 ~ 9.0	165	107	27 ~ 57	29	45	GDP-09				
3120 00509195	-195	1	2.5 ~ 9.0	195	137	27 ~ 57	29	45	GDP-09				
3120 00509225	-225	1	2.5 ~ 9.0	225	167	27 ~ 57	29	45	GDP-09				
3120 00509255	-255	1	2.5 ~ 9.0	255	197	27 ~ 57	29	45	GDP-09				
3120 00512105	BT50 -GDZ12 -105	1	2.5 ~ 12.0	105	43	33 ~ 69	34	56	GDP-12		FDC-12AA	FK-0034	L-4T
3120 00512120	-120	1	2.5 ~ 12.0	120	58	33 ~ 69	34	56	GDP-12				
3120 00512135	-135	1	2.5 ~ 12.0	135	73	33 ~ 69	34	56	GDP-12				
3120 00512165	-165	1	2.5 ~ 12.0	165	103	33 ~ 69	34	56	GDP-12				
3120 00512195	-195	1	2.5 ~ 12.0	195	133	33 ~ 69	34	56	GDP-12				
3120 00512225	-225	1	2.5 ~ 12.0	225	163	33 ~ 69	34	56	GDP-12				
3120 00512255	-255	1	2.5 ~ 12.0	255	193	33 ~ 69	34	56	GDP-12				
3120 00516105	BT50 -GDZ16 -105	1	3.5 ~ 16.0	105	43	38 ~ 82	38	62	GDP-16		FDC-16AA	FK-0034	L-4T
3120 00516120	-120	1	3.5 ~ 16.0	120	58	38 ~ 82	38	62	GDP-16				
3120 00516135	-135	1	3.5 ~ 16.0	135	73	38 ~ 82	38	62	GDP-16	4.4			
3120 00516165	-165	1	3.5 ~ 16.0	165	103	38 ~ 82	38	62	GDP-16				
3120 00516195	-195	1	3.5 ~ 16.0	195	133	38 ~ 82	38	62	GDP-16				
3120 00516225	-225	1	3.5 ~ 16.0	225	163	38 ~ 82	38	62	GDP-16				
3120 00516255	-255	1	3.5 ~ 16.0	255	193	38 ~ 82	38	62	GDP-16				
3120 00522105	BT50 -GDZ22 -105	1	3.5 ~ 22.0	105	39	47 ~ 103	49	76	GDP-22	4.5	FDC-22AA	FK-0045	L-5T
3120 00522120	-120	1	3.5 ~ 22.0	120	54	47 ~ 103	49	76	GDP-22				
3120 00522135	-135	1	3.5 ~ 22.0	135	69	47 ~ 103	49	76	GDP-22				
3120 00522150	-150	1	3.5 ~ 22.0	150	84	47 ~ 103	49	76	GDP-22				
3120 00522165	-165	1	3.5 ~ 22.0	165	99	47 ~ 103	49	76	GDP-22	5.2			
3120 00522195	-195	1	3.5 ~ 22.0	195	129	47 ~ 103	49	76	GDP-22	5.6			
3120 00522225	-225	1	3.5 ~ 22.0	225	159	47 ~ 103	49	76	GDP-22				
3120 00522255	-255	1	3.5 ~ 22.0	255	189	47 ~ 103	49	76	GDP-22				

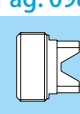
- La boquilla, el tornillo de preajuste, la llave inglesa y la llave Allen se venden por separado.
- Siempre use boquillas de categoría "AA".
- Consulte la pág. 088 para conocer la longitud mínima para insertar herramientas en caso de usar nuestras boquillas refrigerantes (OH, C o MS).
- L2 indica la dimensión cuando se use con un tornillo de preajuste.
- Diríjase a la pág. 485 para conocer el Torque recomendado para nuestros productos.
 - Collet, preset screw, spanner and hex. wrench are sold separately.
 - Always use AA class collet.
 - Refer to P. 088 for minimum tool insertion length in case of using our coolant collets (OH,C or MS).
 - L2 indicates dimension when using with a preset screw.
 - See P. 485 for standard Tightening Torque.

Boquilla Collet Pág. 090-093 	Llave Inglesa Spanner Pág. 099 	Tornillo de preajuste Preset screw Pág. 098 	Llave Allen Hex.Wrench Pág. 099 
--	--	---	---

Ejemplo para Ordenar - Ordering Example

BT40	- GDZ	09	- 90
Interfaz y diámetro de husillo Shank size	Máx. Diámetro Interno de boquilla Max. collet I.D.	Longitud de proyección Projection length (L)	

"R" Zero Holder For Small Diameters

- La precisión del borde de corte puede ajustarse hasta casi cero.
- Para barrenados en espacios reducidos.
- Runout accuracy of the cutting edge can be adjusted as closely as to zero.
- For drilling in tight space.

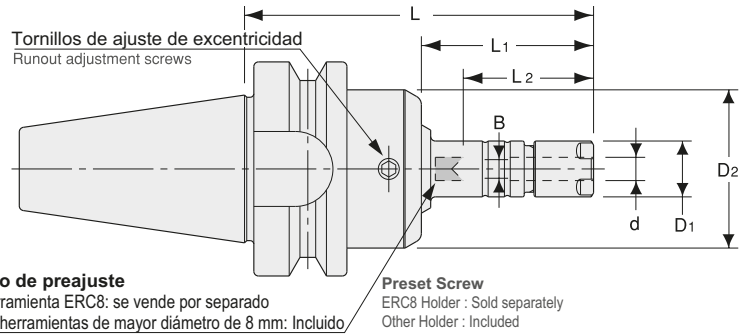

Unidad : Métrico
Unit : Metric

Código Code	Modelo Model	d	L	L1	B	L2	D1	D2	Tuerca ciega Nut	Boquilla Collet	Llave Inglesa Spanner	Llave Allen Hex.Wrench
3130 00108060	BT30 -ERZ8 -60	0.5~5.0	60	22	— (0 ~ 3.1)	33 (19 ~ 29)	12	34	ERP-8	ER8 Se vende por separado / Sold separately	S-8E	L-3T
3130 00108075	-75	0.5~5.0	75	37	— (0 ~ 3.1)	33 (19 ~ 29)	12	34	ERP-8			
3130 00108090	-90	0.5~5.0	90	52	— (0 ~ 3.1)	33 (19 ~ 29)	12	34	ERP-8			
3130 00108105	-105	0.5~5.0	105	67	— (0 ~ 3.1)	33 (19 ~ 29)	12	34	ERP-8			
3130 00110060	BT30 -ERZ11S -60	0.5~7.0	60	22	0 ~ 4	22 ~ 42	16	34	ERP-11S	ER11	S-11E	L-3T
3130 00110075	-75	0.5~7.0	75	37	0 ~ 4	22 ~ 42	16	34	ERP-11S			
3130 00110090	-90	0.5~7.0	90	52	0 ~ 4	22 ~ 42	16	34	ERP-11S			
3130 00110105	-105	0.5~7.0	105	67	0 ~ 4	22 ~ 42	16	34	ERP-11S			
3130 00308075	BT40 -ERZ8 -75	0.5~5.0	75	32	— (0 ~ 3.1)	33 (19 ~ 29)	12	34	ERP-8	ER8 Se vende por separado / Sold separately	S-8E	L-3T
3130 00308090	-90	0.5~5.0	90	47	— (0 ~ 3.1)	33 (19 ~ 29)	12	34	ERP-8			
3130 00308105	-105	0.5~5.0	105	62	— (0 ~ 3.1)	33 (19 ~ 29)	12	34	ERP-8			
3130 00308135	-135	0.5~5.0	135	92	— (0 ~ 3.1)	33 (19 ~ 29)	12	34	ERP-8			
3130 00310075	BT40 -ERZ11S -75	0.5~7.0	75	32	0 ~ 4	22 ~ 42	16	34	ERP-11S	ER11	S-11E	L-3T
3130 00310090	-90	0.5~7.0	90	47	0 ~ 4	22 ~ 42	16	34	ERP-11S			
3130 00310105	-105	0.5~7.0	105	62	0 ~ 4	22 ~ 42	16	34	ERP-11S			
3130 00310135	-135	0.5~7.0	135	92	0 ~ 4	22 ~ 42	16	34	ERP-11S			

1. La boquilla, la llave inglesa y la llave Allen se venden por separado.
2. El ES8, un tornillo de preajuste para el ERZ8, se vende por separado. El ERZ11S incluye un tornillo estándar de preajuste HDS-07A-ES11.
3. Las dimensiones "B" y "L2" son para usar el tornillo de preajuste ES8.
4. Diríjase a la pág. 88 para conocer la longitud mínima de inserción de la herramienta en caso de que use nuestras boquillas para refrigerante.
5. Diríjase a la pág. 485 para conocer el Torque recomendado para nuestros productos.

1. Collet ,spanner and hex. wrench are sold separately.
2. ES8, a preset screw for ERZ8, is sold separately. ERZ11S includes a standard preset screw HDS-07A-ES11.
3. " B " and " L2 " dimensions in brackets are for using ES8 preset screw.
4. Refer to P. 88 for minimum tool insertion length in case of using our coolant collets.
5. See P.485 for standard Tightening Torque.

Boquilla Collet	Llave Inglesa Spanner	Tornillo de preajuste Preset screw	Llave Allen Hex. Wrench
Pág. 094-095	Pág. 099	Pág. 098	Pág. 099

Ejemplo para Ordenar - Ordering Example

BT40	- ERZ	8	-	105
Interfaz y diámetro de husillo		Máx. Diámetro Interno de boquilla		Longitud de proyección
Shank size		Max. collet I.D.		Projection length (L)

PHZ · S

Slim Hydro "R" Zero Holder

- La precisión del borde de corte puede ajustarse hasta casi cero.
- Runout accuracy of the cutting edge can be adjusted as closely as to zero.

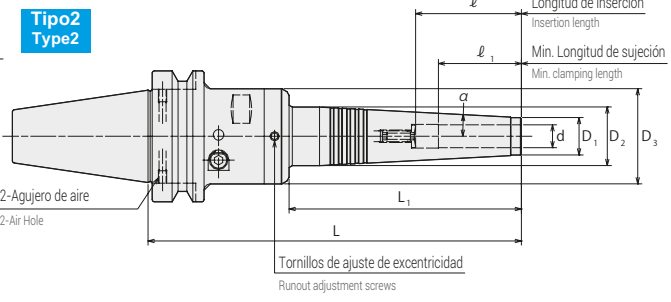
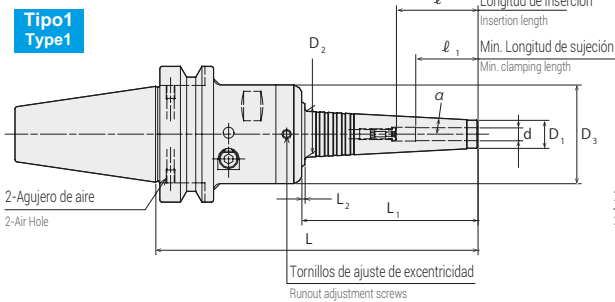

Medidas Métricas - Metric Sizes

Unidad : Métrico
Unit : Metric

Código Code	Modelo Model	Tipo Type	d	L	L1	L2	D1	D2	D3	ℓ	ℓ1	α	Llave Allen para el tornillo de accionamiento (Opcional) Hex. wrench for the actuating screw (Optional)	Llave Allen para Tornillos de ajuste de excentricidad (Opcional) Hex. wrench for runout adjustment screw (Optional)	
3600 00106150	BT30 -PHZ06S	-150	1	6	150	82	1.5	13	21.5	46	37	29	3°	L-4T	L-3T
3600 00106180	-180	1	6	180	112	1.5	13	24.6	46	37	29	3°			
3600 00107150	-PHZ07S	-150	1	7	150	82	1.5	14	22.5	46	37	29	3°		
3600 00107180	-180	1	7	180	112	1.5	14	25.6	46	37	29	3°			
3600 00108150	-PHZ08S	-150	1	8	150	82	1.5	15	23.5	46	50	29	3°		
3600 00108180	-180	1	8	180	112	1.5	15	26.6	46	50	29	3°			
3600 00109150	-PHZ09S	-150	1	9	150	82	1.5	16	24.5	46	50	40	3°		
3600 00109180	-180	1	9	180	112	—	16	27.6	46	50	40	3°			
3600 00110150	-PHZ10S	-150	1	10	150	82	1.5	17	25.5	46	50	40	3°		
3600 00110180	-180	2	10	180	112	—	17	28.2	46	50	40	3°			
3600 00111150	-PHZ11S	-150	1	11	150	82	1.5	18	26.5	46	50	40	3°		
3600 00111180	-180	2	11	180	112	—	18	28.2	46	50	40	3°			
3600 00112150	-PHZ12S	-150	1	12	150	82	—	19	27.4	46	70	40	3°		
3600 00112180	-180	2	12	180	112	—	19	28.2	46	70	40	3°			
3600 00306150	BT40 -PHZ06S	-150	1	6	150	82	1.5	13	21.5	46	37	29	3°	L-4T	L-3T
3600 00306180	-180	1	6	180	112	1.5	13	24.6	46	37	29	3°			
3600 00307150	-PHZ07S	-150	1	7	150	82	1.5	14	22.5	46	37	29	3°		
3600 00307180	-180	1	7	180	112	1.5	14	25.6	46	37	29	3°			
3600 00308150	-PHZ08S	-150	1	8	150	82	1.5	15	23.5	46	50	29	3°		
3600 00308180	-180	1	8	180	112	1.5	15	26.6	46	50	29	3°			
3600 00309150	-PHZ09S	-150	1	9	150	82	1.5	16	24.5	46	50	40	3°		
3600 00309180	-180	1	9	180	112	—	16	27.6	46	50	40	3°			
3600 00310150	-PHZ10S	-150	1	10	150	82	1.5	17	25.5	46	50	40	3°		
3600 00310180	-180	2	10	180	112	—	17	28.2	46	50	40	3°			
3600 00311150	-PHZ11S	-150	1	11	150	82	1.5	18	26.5	46	50	40	3°		
3600 00311180	-180	2	11	180	112	—	18	28.2	46	50	40	3°			
3600 00312150	-PHZ12S	-150	1	12	150	82	—	19	27.4	46	70	40	3°		
3600 00312180	-180	2	12	180	112	—	19	28.2	46	70	40	3°			
3600 00506165	BT50 -PHZ06S	-165	1	6	165	82	1.5	13	21.5	46	37	29	3°	L-4T	L-3T
3600 00506195	-195	1	6	195	112	1.5	13	24.6	46	37	29	3°			
3600 00507165	-PHZ07S	-165	1	7	165	82	1.5	14	22.5	46	37	29	3°		
3600 00507195	-195	1	7	195	112	1.5	14	25.6	46	37	29	3°			
3600 00508165	-PHZ08S	-165	1	8	165	82	1.5	15	23.5	46	50	29	3°		
3600 00508195	-195	1	8	195	112	1.5	15	26.6	46	50	29	3°			
3600 00509165	-PHZ09S	-165	1	9	165	82	1.5	16	24.5	46	50	40	3°		
3600 00509195	-195	1	9	195	112	—	16	27.6	46	50	40	3°			
3600 00510165	-PHZ10S	-165	1	10	165	82	1.5	17	25.5	46	50	40	3°		
3600 00510195	-195	2	10	195	112	—	17	28.2	46	50	40	3°			
3600 00511165	-PHZ11S	-165	1	11	165	82	1.5	18	26.5	46	50	40	3°		
3600 00511195	-195	2	11	195	112	—	18	28.2	46	50	40	3°			
3600 00512165	-PHZ12S	-165	1	12	165	82	—	19	27.4	46	70	40	3°		
3600 00512195	-195	2	12	195	112	—	19	28.2	46	70	40	3°			

1. La tolerancia del diámetro del zanco de la herramienta debe ser dentro de h6.
2. No deje el portaherramienta con el tornillo de accionamiento ajustado cuando el portaherramienta esté vacío.
3. Los tornillos Allen opresor (incluidos) son necesarios para taponar los orificios de aire para el abastecimiento de suministro a través del centro.

1. Tool shank diameter tolerance must be within h6.
2. Do not leave the holder with actuating screw tightened when the chuck is empty.
3. Hex-head screws (included) are necessary to plug air hole for center through coolant feed.

Torque recomendado (Llave de torque : pág. 484)
Tightening torque (Torque wrench : p. 484)

Modelo Model	I.D. (d)		Torque recomendado Tightening torque (Nm)
	mm	pulgada - inch	
PHZ·S	06 ~ 12	—	9 ~ 10

Ejemplo para Ordenar - Ordering Example

BT40 - PHZ 8 S - 105

Interfaz y diámetro de husillo
Shank size

Máx. Diámetro Interno de boquilla
Max. collet I.D.

Longitud de proyección
Projection length (L)

Llave Allen Hex. Wrench

Pág. 099



PHC-A



Power Hydro Chuck

- Portaherramienta Hidráulico con compatibilidad para el uso de boquillas. Adecuado para cortes de alta precisión.
- Hydro chuck with collet holder flexibility. Suitable for high precision cutting.

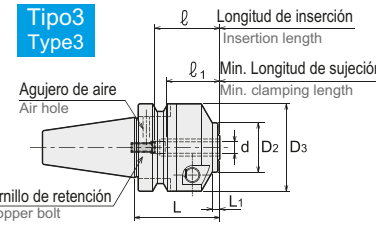
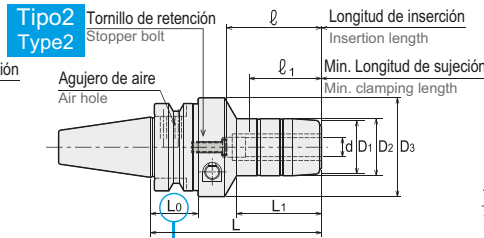
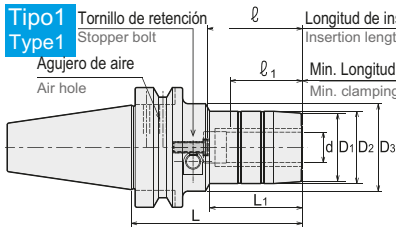

Para PHC03 & PHC04, El tornillo de retención no está incluido. Favor de ordenar por separado (producto especial).
For PHC03A & PHC04A, the stopper bolt is not included. Please order separately (Special item).

⚠ Precaución/Caution
★ : Tome precaución con la interferencia del brazo del A.T.C (automatic tool changer) y el cartucho "magazine" de herramientas.
★ : Take caution against A.T.C. arm and tool magazine interference.

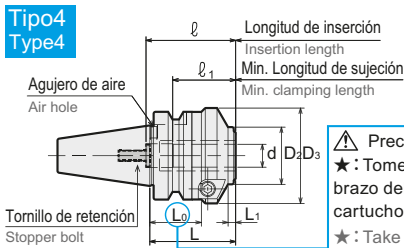

⚠ Precaución/Caution
★ : Tome precaución con la interferencia del brazo del A.T.C (automatic tool changer) y el cartucho "magazine" de herramientas.
★ : Take caution against A.T.C. arm and tool magazine interference.

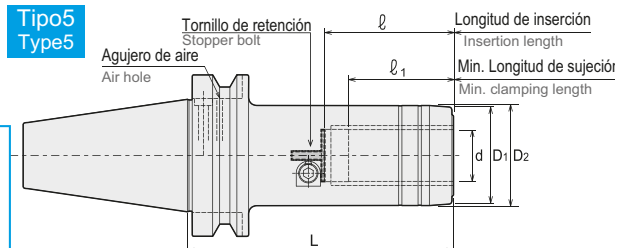

Código Code	Modelo Model	Tipo Type	d	L	L ₁	D ₁	D ₂	D ₃	L ₀	ℓ	ℓ ₁	Max. min ⁻¹	Kg	Llave Allen (Opcional) Hex. Wrench (Optional)
3930 01103045	BT30 -PHC03A - 45	3	3	45	4	—	24	46	—	—	18	40,000	0.6	L-4T (4mm)
3930 01103060	- 60	1	3	60	19.8	—	24	46	—	27	18	38,000	0.7	
3930 01103090	- 90	1	3	90	44.8	—	24	46	—	49	18	36,000	0.8	
3930 01104045	-PHC04A - 45	3	4	45	4	—	25	46	—	—	24	40,000	0.6	
3930 01104065	- 65	1	4	65	25.1	—	25	46	—	29	24	38,000	0.7	
3930 01104090	- 90	1	4	90	45.1	—	25	46	—	49	24	36,000	0.8	
3930 01106045	-PHC06A - 45	3	6	45	4	—	26	46	—	34	29	37,000	0.6	
3930 01106075	- 75	1	6	75	30	24	26	46	—	34	29	35,000	0.7	
3930 01107045	-PHC07A - 45	3	7	45	4	—	28	46	—	34	29	36,000	0.6	
3930 01107075	- 75	1	7	75	30	26	28	46	—	34	29	34,000	0.8	
3930 01108045	-PHC08A - 45	3	8	45	4	—	28	46	—	34	29	36,000	0.6	
3930 01108075	- 75	1	8	75	30	26	28	46	—	34	29	34,000	0.8	
3930 01109045	-PHC09A - 45	3	9	45	4	—	30	46	—	45	33	36,000	0.6	
3930 01109090	- 90	1	9	90	46	28	30	46	—	55	40	33,000	0.8	
3930 01109105	- 105	2	9	105	44	28	30	52	40	50	40	27,000	1.1	
3930 01110045	-PHC10A - 45	3	10	45	4	—	30	46	—	45	33	35,000	0.6	
3930 01110090	- 90	1	10	90	46	28	30	46	—	55	40	32,000	0.8	
3930 01110105	- 105	2	10	105	44	28	30	52	40	50	40	27,000	1.1	
3930 01111045	-PHC11A - 45	3	11	45	4	—	30	46	—	45	33	34,000	0.6	
3930 01111090	- 90	1	11	90	46	30	32	46	—	55	40	31,000	0.9	
3930 01111105	- 105	2	11	105	45	30	32	52	40	50	40	27,000	1.1	
3930 01112045	-PHC12A - 45*	3	12	45	4	—	30	46	—	45	33	32,000	0.6	
3930 01112090	- 90*	1	12	90	46	30	32	46	—	55	40	30,000	0.9	
3930 01112105	- 105*	2	12	105	45	30	32	52	40	50	40	26,000	1.1	
3930 01113045	-PHC13A - 45	4	13	45	4	—	30	50	27	45	33	30,000	0.6	
3930 01113090	- 90	1	13	90	48	34	36	46	—	55	40	27,000	0.9	
3930 01113105	- 105	2	13	105	46	34	36	52	40	50	40	24,000	1.2	
3930 01114045	-PHC14A - 45	4	14	45	4	—	30	50	27	45	33	28,000	0.6	
3930 01114090	- 90	1	14	90	48	34	36	46	—	55	40	26,000	1.0	
3930 01114105	- 105	2	14	105	46	34	36	52	40	50	40	23,000	1.2	
3930 01115045	-PHC15A - 45	4	15	45	4	—	30	50	27	45	33	26,000	0.6	
3930 01115090	- 90	1	15	90	48	36	38	46	—	55	40	24,000	1.0	
3930 01115105	- 105	2	15	105	46	36	38	52	40	50	40	22,000	1.2	
3930 01116045	-PHC16A - 45	4	16	45	4	—	30	50	27	45	33	24,000	0.6	
3930 01116090	- 90	1	16	90	48	36	38	46	—	55	40	22,000	1.0	
3930 01116105	- 105	2	16	105	46	36	38	52	40	50	40	20,000	1.2	
3930 01120090	-PHC20A - 90*	1	20	90	49	40	42	46	—	50	40	20,000	1.0	
3930 01120120	- 120*	1	20	120	69	40	42	46	—	70	40	18,000	1.3	
3930 01303065	BT40 -PHC03A - 65	1	3	65	19.8	—	24	46	—	27	18	20,000	1.2	
3930 01303090	- 90	1	3	90	44.8	—	24	46	—	49	18	20,000	1.3	
3930 01304070	-PHC04A - 70	1	4	70	25.1	—	25	46	—	29	24	20,000	1.3	
3930 01304090	- 90	1	4	90	45.1	—	25	46	—	49	24	20,000	1.3	
3930 01306075	-PHC06A - 75	1	6	75	30	24	26	46	—	34	29	20,000	1.3	
3930 01306105	- 105	1	6	105	41	24	26	46	—	45	29	20,000	1.5	

Código Code	Modelo Model	Tipo Type	d	L	L ₁	D ₁	D ₂	D ₃	L ₀	ℓ	ℓ ₁	Max. min ⁻¹	Kg	Llave Allen (Opcional) Hex. Wrench (Optional)
3930 01307075	BT40 -PHC07A - 75	1	7	75	30	26	28	46	—	34	29	20,000	1.3	L-4T (4mm)
3930 01307105	- 105	1	7	105	41	26	28	46	—	45	29	20,000	1.4	
3930 01308075	-PHC08A - 75	1	8	75	30	26	28	46	—	34	29	20,000	1.3	
3930 01308105	- 105	1	8	105	41	26	28	46	—	45	29	20,000	1.6	
3930 01309090	-PHC09A - 90	1	9	90	44	28	30	52	—	50	40	20,000	1.4	
3930 01309120	- 120	1	9	120	64	28	30	52	—	70	40	20,000	1.7	
3930 01310090	-PHC10A - 90	1	10	90	44	28	30	52	—	50	40	20,000	1.4	
3930 01310120	- 120	1	10	120	64	28	30	52	—	70	40	20,000	1.7	
3930 01311090	-PHC11A - 90	1	11	90	45	30	32	52	—	50	40	20,000	1.4	
3930 01311120	- 120	1	11	120	65	30	32	52	—	70	40	20,000	1.7	
3930 01312090	-PHC12A - 90*	1	12	90	45	30	32	52	—	50	40	20,000	1.4	
3930 01312120	- 120*	1	12	120	65	30	32	52	—	70	40	20,000	1.7	
3930 01313090	-PHC13A - 90	1	13	90	46	34	36	52	—	50	40	20,000	1.5	
3930 01313120	- 120	1	13	120	66	34	36	52	—	70	40	20,000	1.8	
3930 01314090	-PHC14A - 90	1	14	90	46	34	36	52	—	50	40	20,000	1.5	
3930 01314120	- 120	1	14	120	66	34	36	52	—	70	40	20,000	1.8	
3930 01315090	-PHC15A - 90	1	15	90	46	36	38	52	—	50	40	20,000	1.5	
3930 01315120	- 120	1	15	120	66	36	38	52	—	70	40	20,000	1.8	
3930 01316090	-PHC16A - 90	1	16	90	46	36	38	52	—	50	40	20,000	1.5	
3930 01316120	- 120	1	16	120	66	36	38	52	—	70	40	20,000	1.8	
3930 01320090	-PHC20A - 90*	1	20	90	49	40	42	46	—	50	40	20,000	1.5	
3930 01320120	- 120*	1	20	120	69	40	42	46	—	70	40	20,000	1.8	
3930 01325105	-PHC25A - 105	1	25	105	59	50	52	62	—	60	50	16,000	2.1	
3930 01325135	- 135	1	25	135	79	50	52	62	—	80	50	15,000	2.5	
3930 01332120	-PHC32A - 120	5	32	120	93	60	62	—	—	75	65	12,000	2.6	
3930 01332150	- 150	5	32	150	123	60	62	—	—	80	65	11,000	3.2	
3930 01506090	BT50 -PHC06A - 90	1	6	90	30	24	26	46	—	34	29	15,000	3.9	
3930 01506120	- 120	1	6	120	41	24	26	46	—	45	29	15,000	4.1	
3930 01506150	- 150	1	6	150	41	24	26	46	—	45	29	15,000	4.4	
3930 01507090	-PHC07A - 90	1	7	90	30	26	28	46	—	34	29	15,000	3.9	
3930 01507120	- 120	1	7	120	41	26	28	46	—	45	29	15,000	4.1	
3930 01507150	- 150	1	7	150	41	26	28	46	—	45	29	15,000	4.5	
3930 01508090	-PHC08A - 90	1	8	90	30	26	28	46	—	34	29	15,000	3.9	
3930 01508120	- 120	1	8	120	41	26	28	46	—	45	29	15,000	4.1	
3930 01508150	- 150	1	8	150	41	26	28	46	—	45	29	15,000	4.5	
3930 01509105	-PHC09A - 105	1	9	105	44	28	30	52	—	50	40	15,000	4.0	
3930 01509135	- 135	1	9	135	64	28	30	52	—	70	40	15,000	4.3	
3930 01509165	- 165	1	9	165	64	28	30	52	—	70	40	15,000	4.7	
3930 01510105	-PHC10A - 105	1	10	105	44	28	30	52	—	50	40	15,000	4.1	
3930 01510135	- 135	1	10	135	64	28	30	52	—	70	40	15,000	4.3	
3930 01510165	- 165	1	10	165	64	28	30	52	—	70	40	15,000	4.7	
3930 01511105	-PHC11A - 105	1	11	105	45	30	32	52	—	50	40	15,000	4.1	
3930 01511135	- 135	1	11	135	65	30	32	52	—	70	40	15,000	4.3	
3930 01511165	- 165	1	11	165	65	30	32	52	—	70	40	15,000	4.7	
3930 01512105	-PHC12A - 105*	1	12	105	45	30	32	52	—	50	40	15,000	4.1	
3930 01512135	- 135*	1	12	135	65	30	32	52	—	70	40	15,000	4.3	
3930 01512165	- 165*	1	12	165	65	30	32	52	—	70	40	15,000	4.7	
3930 01513105	-PHC13A - 105	1	13	105	46	34	36	52	—	50	40	15,000	4.2	
3930 01513135	- 135	1	13	135	66	34	36	52	—	70	40	15,000	4.4	
3930 01513165	- 165	1	13	165	66	34	36	52	—	70	40	15,000	4.8	
3930 01514105	-PHC14A - 105	1	14	105	46	34	36	52	—	50	40	15,000	4.1	
3930 01514135	- 135	1	14	135	66	34	36	52	—	70	40	15,000	4.4	
3930 01514165	- 165	1	14	165	66	34	36	52	—	70	40	15,000	4.8	
3930 01515105	-PHC15A - 105	1	15	105	46	36	38	52	—	50	40	15,000	4.1	
3930 01515135	- 135	1	15	135	66	36	38	52	—	70	40	15,000	4.4	
3930 01515165	- 165	1	15	165	66	36	38	52	—	70	40	15,000	4.8	
3930 01516105	-PHC16A - 105	1	16	105	46	36	38	52	—	50	40	15,000	4.1	
3930 01516135	- 135	1	16	135	66	36	38	52	—	70	40	15,000	4.4	
3930 01516165	- 165	1	16	165	66	36	38	52	—	70	40	15,000	4.8	
3930 01520105	-PHC20A - 105*	1	20	105	49	40	42	46	—	50	40	15,000	4.1	
3930 01520135	- 135*	1	20	135	69	40	42	46	—	70	40	15,000	4.4	
3930 01520165	- 165*	1	20	165	69	40	42	46	—	70	40	15,000	4.7	
3930 01525120	-PHC25A - 120	1	25	120	59	50	52	62	—	64	50	15,000	4.7	
3930 01525150	- 150	1	25	150	79	50	52	62	—	80	50	15,000	5.2	
3930 01525165	- 165	1	25	165	79	50	52	62	—	80	50	15,000	5.5	
3930 01532135	-PHC32A - 135	5	32	135	—	60	62	—	—	75	65	12,000	5.2	
3930 01532165	- 165	5	32	165	—	60	62	—	—	80	65	12,000	5.8	

- El zanco de la herramienta de corte debe estar dentro de las tolerancias especificadas a continuación; diámetro del zanco menor a 6 mm: dentro de la tolerancia h6, diámetro del zanco mayor a 6 mm: dentro de la tolerancia h7, h6 o 0/-0.01 es la tolerancia recomendada en las herramientas de corte al usar nuestros productos.
- PHC12A y PHC20A cuentan con orificios de acople, para las boquillas que tienen incluida la clavija de tope.
- El tornillo Allen opresor (incluido) es necesario para tapar el orificio de aire para habilitar la alimentación de refrigeración por vena de lubricación de la herramienta.
- Para PHC03A & PHC04A, la unidad de ajuste de longitud no puede ser utilizada.
- La velocidad permitida es gravemente afectada por la rigidez del husillo de la máquina y el balance de la herramienta de corte. Gradualmente incrementar la velocidad hasta llegar a la velocidad apropiada.
- * Posible utilizar boquillas PHS.

- Cutting tool shank must be within tolerances specified below; Shank diameter less than 6mm : Within h6 tolerance, shank diameter 6mm and over : Within h7 tolerance, h6 or 0/-0.01 tolerance is recommended when newly making a cutting tool.
- PHC12A and PHC20A have pin holes for collet with stopper pin on its body.
- Hex-head screws (included) are necessary to plug air hole for center through coolant feed.
- For PHC03A & PHC04A, the length adjustment unit cannot be used.
- Allowed speed is greatly affected by the stiffness of the machine spindle and the balance of the cutting tool. Gradually increase from a low speed, and use at the proper speed.
- * Compatible for PHS collet use.

Boquilla PHS
PHS Collet

Pág. 114

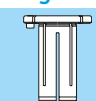

Llave Allen
Hex. Wrench

Pág. 99



Ejemplo para Ordenar - Ordering Example

BT50 - PHC 12 A - 135

Interfaz y diámetro de husillo Shank size	Diámetro Interno I.D.	Longitud de proyección Projection length
--	---------------------------------	--

Unidad de ajuste de longitud - Length adjustment unit

Llave Allen para ajuste de la altura
Hex. Wrench for height adjustment

Para menor longitud de proyección
For shorter projection length

Para mayor longitud de proyección
For longer projection length

Interfaz y diámetro de husillo
Shank size

Medida de la llave allen para ajuste de altura
Hex. Wrench size for height adjustment

Herramienta para instalación / desinstalación de la unidad de ajuste longitudinal
Install / removal tool for length adjustment unit

BT30

2.5mm

STS-R1

BT40

2.5mm

STS-R2

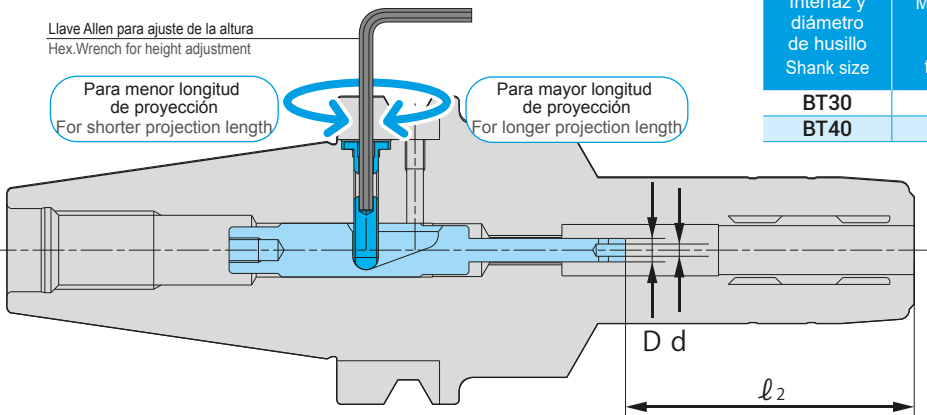

Unidad : Métrico
Unit : Metric

Código Code	Unidad de ajuste longitud Length adjustment unit	Portaherramienta correspondiente Matched chuck	Rango de ajuste Adjustment range l_2	Cantidad de ajuste Adjustable amount	Diámetro interno del extremo del pasador Pin end I.D.	Diámetro externo del extremo del pasador Pin end O.D.
3934 23044023	PHC - P304 - 4023	BT30 -PHC06A - 75	29-34	5	2	3.8
3934 23044023	PHC - P304 - 4023	BT30 -PHC07A - 75	29-34	5	2	3.8
3934 23044023	PHC - P304 - 4023	BT30 -PHC08A - 75	29-34	5	2	3.8
3934 23053730	PHC - P305 - 3730	BT30 -PHC09A - 90	40-45	5	2.5	4.8
3934 23053725	PHC - P305 - 3725	- 90	45-50	5	2.5	4.8
3934 23053720	PHC - P305 - 3720	- 90	50-55	5	2.5	4.8
3934 23054537	PHC - P305 - 4537	- 105	40-45	5	2.5	4.8
3934 23054532	PHC - P305 - 4532	- 105	45-50	5	2.5	4.8
3934 23053730	PHC - P305 - 3730	BT30 -PHC10A - 90	40-45	5	2.5	4.8
3934 23053725	PHC - P305 - 3725	- 90	45-50	5	2.5	4.8
3934 23053720	PHC - P305 - 3720	- 90	50-55	5	2.5	4.8
3934 23054537	PHC - P305 - 4537	- 105	40-45	5	2.5	4.8
3934 23054532	PHC - P305 - 4532	- 105	45-50	5	2.5	4.8
3934 23053730	PHC - P305 - 3730	BT30 -PHC11A - 90	40-45	5	2.5	4.8
3934 23053725	PHC - P305 - 3725	- 90	45-50	5	2.5	4.8
3934 23053720	PHC - P305 - 3720	- 90	50-55	5	2.5	4.8
3934 23054537	PHC - P305 - 4537	- 105	40-45	5	2.5	4.8
3934 23054532	PHC - P305 - 4532	- 105	45-50	5	2.5	4.8
3934 23053730	PHC - P305 - 3730	BT30 -PHC12A - 90	40-45	5	2.5	4.8
3934 23053725	PHC - P305 - 3725	- 90	45-50	5	2.5	4.8
3934 23053720	PHC - P305 - 3720	- 90	50-55	5	2.5	4.8
3934 23054537	PHC - P305 - 4537	- 105	40-45	5	2.5	4.8
3934 23054532	PHC - P305 - 4532	- 105	45-50	5	2.5	4.8
3934 23053730	PHC - P305 - 3730	BT30 -PHC13A - 90	40-45	5	2.5	4.8
3934 23053725	PHC - P305 - 3725	- 90	45-50	5	2.5	4.8
3934 23053720	PHC - P305 - 3720	- 90	50-55	5	2.5	4.8
3934 23054537	PHC - P305 - 4537	- 105	40-45	5	2.5	4.8
3934 23054532	PHC - P305 - 4532	- 105	45-50	5	2.5	4.8
3934 23053730	PHC - P305 - 3730	BT30 -PHC14A - 90	40-45	5	2.5	4.8
3934 23053725	PHC - P305 - 3725	- 90	45-50	5	2.5	4.8
3934 23053720	PHC - P305 - 3720	- 90	50-55	5	2.5	4.8
3934 23054537	PHC - P305 - 4537	- 105	40-45	5	2.5	4.8
3934 23054532	PHC - P305 - 4532	- 105	45-50	5	2.5	4.8
3934 23053730	PHC - P305 - 3730	BT30 -PHC15A - 90	40-45	5	2.5	4.8
3934 23053725	PHC - P305 - 3725	- 90	45-50	5	2.5	4.8
3934 23053720	PHC - P305 - 3720	- 90	50-55	5	2.5	4.8
3934 23054537	PHC - P305 - 4537	- 105	40-45	5	2.5	4.8
3934 23054532	PHC - P305 - 4532	- 105	45-50	5	2.5	4.8
3934 23053730	PHC - P305 - 3730	BT30 -PHC16A - 90	40-45	5	2.5	4.8
3934 23053725	PHC - P305 - 3725	- 90	45-50	5	2.5	4.8
3934 23053720	PHC - P305 - 3720	- 90	50-55	5	2.5	4.8
3934 23054537	PHC - P305 - 4537	- 105	40-45	5	2.5	4.8
3934 23054532	PHC - P305 - 4532	- 105	45-50	5	2.5	4.8
3934 23054027	PHC - P305 - 4027	BT30 -PHC20A - 90	40-45	5	2.5	4.8
3934 23054022	PHC - P305 - 4022	- 90	45-50	5	2.5	4.8
3934 23054542	PHC - P305 - 4542	- 120	50-55	5	2.5	4.8
3934 23054537	PHC - P305 - 4537	- 120	55-60	5	2.5	4.8
3934 23054532	PHC - P305 - 4532	- 120	60-65	5	2.5	4.8
3934 24044423	PHC - P404 - 4423	BT40 -PHC06A - 75	29-34	5	2	3.8
3934 24046334	PHC - P404 - 6334	- 105	29-39	10	2	3.8
3934 24046328	PHC - P404 - 6328	- 105	35-45	10	2	3.8

Medidas Métricas - Metric Sizes

Unidad : Métrico
Unit : Metric

Código Code	Unidad de ajuste de longitud Length adjustment unit	Portaherramienta correspondiente Matched chuck	Rango de ajuste Adjustment range ₂	Cantidad de ajuste Adjustable amount	Diámetro interno del extremo del pasador Pin end I.D.	Diámetro externo del extremo del pasador Pin end O.D.
3934 24044423	PHC - P404 - 4423	BT40 -PHC07A - 75	29-34	5	2	3.8
3934 24046334	PHC - P404 - 6334	- 105	29-39	10	2	3.8
3934 24046328	PHC - P404 - 6328	- 105	35-45	10	2	3.8
3934 24044423	PHC - P404 - 4423	BT40 -PHC08A - 75	29-34	5	2	3.8
3934 24046334	PHC - P404 - 6334	- 105	29-39	10	2	3.8
3934 24046328	PHC - P404 - 6328	- 105	35-45	10	2	3.8
3934 24054427	PHC - P405 - 4427	BT40 -PHC09A - 90	40-50	10	2.5	4.8
3934 24054952	PHC - P405 - 4952	- 120	40-50	10	2.5	4.8
3934 24054942	PHC - P405 - 4942	- 120	50-60	10	2.5	4.8
3934 24054932	PHC - P405 - 4932	- 120	60-70	10	2.5	4.8
3934 24054427	PHC - P405 - 4427	BT40 -PHC10A - 90	40-50	10	2.5	4.8
3934 24054952	PHC - P405 - 4952	- 120	40-50	10	2.5	4.8
3934 24054942	PHC - P405 - 4942	- 120	50-60	10	2.5	4.8
3934 24054932	PHC - P405 - 4932	- 120	60-70	10	2.5	4.8
3934 24054427	PHC - P405 - 4427	BT40 -PHC11A - 90	40-50	10	2.5	4.8
3934 24054952	PHC - P405 - 4952	- 120	40-50	10	2.5	4.8
3934 24054942	PHC - P405 - 4942	- 120	50-60	10	2.5	4.8
3934 24054932	PHC - P405 - 4932	- 120	60-70	10	2.5	4.8
3934 24054427	PHC - P405 - 4427	BT40 -PHC12A - 90	40-50	10	2.5	4.8
3934 24054952	PHC - P405 - 4952	- 120	40-50	10	2.5	4.8
3934 24054942	PHC - P405 - 4942	- 120	50-60	10	2.5	4.8
3934 24054932	PHC - P405 - 4932	- 120	60-70	10	2.5	4.8
3934 24054427	PHC - P405 - 4427	BT40 -PHC13A - 90	40-50	10	2.5	4.8
3934 24054952	PHC - P405 - 4952	- 120	40-50	10	2.5	4.8
3934 24054942	PHC - P405 - 4942	- 120	50-60	10	2.5	4.8
3934 24054932	PHC - P405 - 4932	- 120	60-70	10	2.5	4.8
3934 24054427	PHC - P405 - 4427	BT40 -PHC14A - 90	40-50	10	2.5	4.8
3934 24054952	PHC - P405 - 4952	- 120	40-50	10	2.5	4.8
3934 24054942	PHC - P405 - 4942	- 120	50-60	10	2.5	4.8
3934 24054932	PHC - P405 - 4932	- 120	60-70	10	2.5	4.8
3934 24054427	PHC - P405 - 4427	BT40 -PHC15A - 90	40-50	10	2.5	4.8
3934 24054952	PHC - P405 - 4952	- 120	40-50	10	2.5	4.8
3934 24054942	PHC - P405 - 4942	- 120	50-60	10	2.5	4.8
3934 24054932	PHC - P405 - 4932	- 120	60-70	10	2.5	4.8
3934 24054427	PHC - P405 - 4427	BT40 -PHC16A - 90	40-50	10	2.5	4.8
3934 24054952	PHC - P405 - 4952	- 120	40-50	10	2.5	4.8
3934 24054942	PHC - P405 - 4942	- 120	50-60	10	2.5	4.8
3934 24054932	PHC - P405 - 4932	- 120	60-70	10	2.5	4.8
3934 24054427	PHC - P405 - 4427	BT40 -PHC20A - 90	40-50	10	2.5	4.8
3934 24054952	PHC - P405 - 4952	- 120	40-50	10	2.5	4.8
3934 24054942	PHC - P405 - 4942	- 120	50-60	10	2.5	4.8
3934 24054932	PHC - P405 - 4932	- 120	60-70	10	2.5	4.8
3934 24054432	PHC - P405 - 4432	BT40 -PHC25A - 105	50-60	10	2.5	4.8
3934 24055452	PHC - P405 - 5452	- 135	50-60	10	2.5	4.8
3934 24055442	PHC - P405 - 5442	- 135	60-70	10	2.5	4.8
3934 24055432	PHC - P405 - 5432	- 135	70-80	10	2.5	4.8
3934 24054432	PHC - P405 - 4432	BT40 -PHC32A - 120	65-75	10	2.5	4.8
3934 24055452	PHC - P405 - 5452	- 150	65-75	10	2.5	4.8
3934 24054952	PHC - P405 - 4952	- 150	70-80	10	2.5	4.8

Ejemplo para ordenar - Ordering Example

BT30-PHC10A-105 con un rango de ajuste de entre 40 - 45 mm. (Cantidad ajustable - 5mm).
BT30-PHC10A-105 with adjustment range of 40-45mm (Adjustable amount-5mm).

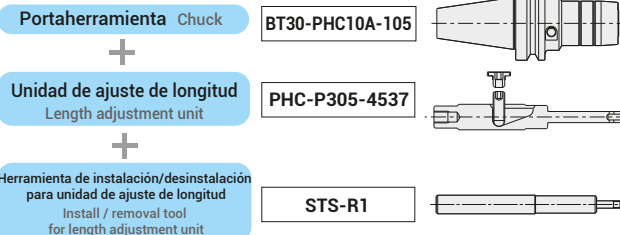

1. La unidad de ajuste de longitud puede ser utilizada por otros portaherramientas excepto los que tengan 45mm de longitud de proyección.
2. La unidad de ajuste de longitud puede ser utilizada únicamente en portaherramientas con interfaz BT, CAT y SK.
3. Para PHC03A & PHC04A, la unidad de ajuste de longitud no puede ser utilizada.

1. Length adjustment unit can be used for Chucks other than 45mm projection length.
2. Length adjustment unit can be used with BT, CAT and SK shank Chucks only.
3. For PHC03A & PHC04A, the length adjustment unit cannot be used.

Boquilla PHS
PHS Collet
Pág. 114

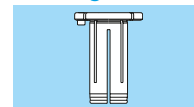

Llave Allen
Hex. Wrench
Pág. 99



Unidad de ajuste longitudinal - Length adjustment unit

Llave Allen para ajuste de la altura
Hex. Wrench for height adjustment

Para menor longitud de proyección
For shorter projection length

Para mayor longitud de proyección
For longer projection length

Interfaz y diámetro de husillo Shank size	Medida de la llave allen para ajuste de altura Hex. Wrench size for height adjustment	Herramienta para instalación / desinstalación de la unidad de ajuste longitudinal Install / removal tool for length adjustment unit
BT50	3mm	STS-R2

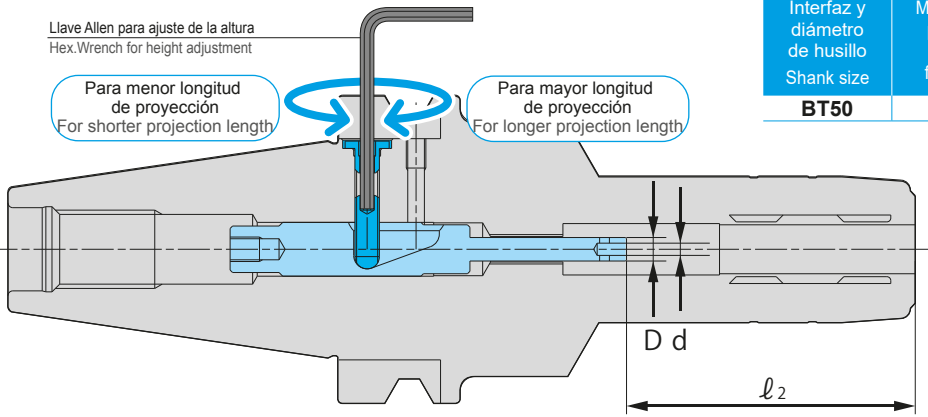

Medidas Métricas - Metric Sizes

Unidad : Métrico
Unit : Metric

Código Code	Unidad de ajuste de longitud Length adjustment unit	Portaherramienta correspondiente Matched chuck	Rango de ajuste Adjustment range l_2	Cantidad de ajuste Adjustable amount	Diámetro interno del extremo del pasador Pin end I.D.	Diámetro externo del extremo del pasador Pin end O.D.
3934 25045129	PHC - P504 - 5129	BT50 -PHC06A - 90	29-34	5	2	3.8
3934 25047139	PHC - P504 - 7139	- 120	29-45	16	2	3.8
3934 25040139	PHC - P504 -10139	- 150	29-45	16	2	3.8
3934 25045129	PHC - P504 - 5129	BT50 -PHC07A - 90	29-34	5	2	3.8
3934 25047139	PHC - P504 - 7139	- 120	29-45	16	2	3.8
3934 25040139	PHC - P504 -10139	- 150	29-45	16	2	3.8
3934 25045129	PHC - P504 - 5129	BT50 -PHC08A - 90	29-34	5	2	3.8
3934 25047139	PHC - P504 - 7139	- 120	29-45	16	2	3.8
3934 25040139	PHC - P504 -10139	- 150	29-45	16	2	3.8
3934 25055133	PHC - P505 - 5133	BT50 -PHC09A - 105	40-50	10	2.5	4.8
3934 25056153	PHC - P505 - 6153	- 135	40-55	15	2.5	4.8
3934 25056138	PHC - P505 - 6138	- 135	55-70	15	2.5	4.8
3934 25059153	PHC - P505 - 9153	- 165	40-55	15	2.5	4.8
3934 25059138	PHC - P505 - 9138	- 165	55-70	15	2.5	4.8
3934 25055133	PHC - P505 - 5133	BT50 -PHC10A - 105	40-50	10	2.5	4.8
3934 25056153	PHC - P505 - 6153	- 135	40-55	15	2.5	4.8
3934 25056138	PHC - P505 - 6138	- 135	55-70	15	2.5	4.8
3934 25059153	PHC - P505 - 9153	- 165	40-55	15	2.5	4.8
3934 25059138	PHC - P505 - 9138	- 165	55-70	15	2.5	4.8
3934 25055133	PHC - P505 - 5133	BT50 -PHC11A - 105	40-50	10	2.5	4.8
3934 25056153	PHC - P505 - 6153	- 135	40-55	15	2.5	4.8
3934 25056138	PHC - P505 - 6138	- 135	55-70	15	2.5	4.8
3934 25059153	PHC - P505 - 9153	- 165	40-55	15	2.5	4.8
3934 25059138	PHC - P505 - 9138	- 165	55-70	15	2.5	4.8
3934 25055133	PHC - P505 - 5133	BT50 -PHC12A - 105	40-50	10	2.5	4.8
3934 25056153	PHC - P505 - 6153	- 135	40-55	15	2.5	4.8
3934 25056138	PHC - P505 - 6138	- 135	55-70	15	2.5	4.8
3934 25059153	PHC - P505 - 9153	- 165	40-55	15	2.5	4.8
3934 25059138	PHC - P505 - 9138	- 165	55-70	15	2.5	4.8
3934 25055133	PHC - P505 - 5133	BT50 -PHC13A - 105	40-50	10	2.5	4.8
3934 25056153	PHC - P505 - 6153	- 135	40-55	15	2.5	4.8
3934 25056138	PHC - P505 - 6138	- 135	55-70	15	2.5	4.8
3934 25059153	PHC - P505 - 9153	- 165	40-55	15	2.5	4.8
3934 25059138	PHC - P505 - 9138	- 165	55-70	15	2.5	4.8
3934 25055133	PHC - P505 - 5133	BT50 -PHC14A - 105	40-50	10	2.5	4.8
3934 25056153	PHC - P505 - 6153	- 135	40-55	15	2.5	4.8
3934 25056138	PHC - P505 - 6138	- 135	55-70	15	2.5	4.8
3934 25059153	PHC - P505 - 9153	- 165	40-55	15	2.5	4.8
3934 25059138	PHC - P505 - 9138	- 165	55-70	15	2.5	4.8
3934 25055133	PHC - P505 - 5133	BT50 -PHC15A - 105	40-50	10	2.5	4.8
3934 25056153	PHC - P505 - 6153	- 135	40-55	15	2.5	4.8
3934 25056138	PHC - P505 - 6138	- 135	55-70	15	2.5	4.8
3934 25059153	PHC - P505 - 9153	- 165	40-55	15	2.5	4.8
3934 25059138	PHC - P505 - 9138	- 165	55-70	15	2.5	4.8
3934 25055133	PHC - P505 - 5133	BT50 -PHC16A - 105	40-50	10	2.5	4.8
3934 25056153	PHC - P505 - 6153	- 135	40-55	15	2.5	4.8
3934 25056138	PHC - P505 - 6138	- 135	55-70	15	2.5	4.8

Medidas Métricas – Metric Sizes

Unidad : Métrico
Unit : Metric

Código Code	Unidad de ajuste de longitud Length adjustment unit	Portaherramienta correspondiente Matched chuck	Rango de ajuste Adjustment range ₂	Cantidad de ajuste Adjustable amount	Diámetro interno del extremo del pasador Pin end I.D.	Diámetro externo del extremo del pasador Pin end O.D.
3934 25059153	PHC - P505 - 9153	- 165	40-55	15	2.5	4.8
3934 25059138	PHC - P505 - 9138	- 165	55-70	15	2.5	4.8
3934 25055133	PHC - P505 - 5133	BT50 -PHC20A - 105	40-50	10	2.5	4.8
3934 25056153	PHC - P505 - 6153	- 135	40-55	15	2.5	4.8
3934 25056138	PHC - P505 - 6138	- 135	55-70	15	2.5	4.8
3934 25059153	PHC - P505 - 9153	- 165	40-55	15	2.5	4.8
3934 25059138	PHC - P505 - 9138	- 165	55-70	15	2.5	4.8
3934 25055138	PHC - P505 - 5138	BT50 -PHC25A - 120	50-64	14	2.5	4.8
3934 25056158	PHC - P505 - 6158	- 150	50-65	15	2.5	4.8
3934 25056143	PHC - P505 - 6143	- 150	65-80	15	2.5	4.8
3934 25057658	PHC - P505 - 7658	- 165	50-65	15	2.5	4.8
3934 25057643	PHC - P505 - 7643	- 165	65-80	15	2.5	4.8
3934 25055138	PHC - P505 - 5138	BT50 -PHC32A - 135	65-75	10	2.5	4.8
3934 25056158	PHC - P505 - 6158	- 165	65-80	15	2.5	4.8

Ejemplo para Ordenar - Ordering Example

BT50-PHC10A-105 con rango de ajuste de 40-45 mm. (Cantidad ajustable -5 mm).
BT50-PHC10A-105 with adjustment range of 40-45mm (Adjustable amount-5mm).

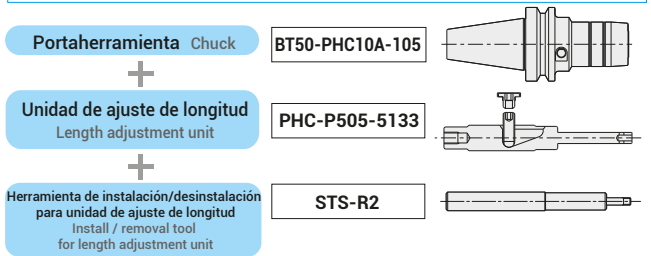

1. La unidad de ajuste de longitud puede ser utilizada por otros portaherramientas excepto los que tengan 45mm de longitud de proyección.
2. La unidad de ajuste de longitud puede ser utilizada únicamente en portaherramientas con interfaz de husillo BT, CAT y SK.

1. Length adjustment unit can be used for Chucks other than 45mm projection length.
2. Length adjustment unit can be used with BT, CAT and SK shank Chucks only.

Boquilla con clavija de tope - Collet with stopper pin

Mínima Longitud de sujeción para PHS

Minimum clamping length for PHS

Boquilla D.I. métrico Collet I.D. $\square d$ Metric	Boquilla D.I. Pulgadas Collet I.D. $\square d$ Inch	Longitud mínima de inserción Min. Clamping length Metric(Inch)
3, 4	1/8	25 (0.984)
5	3/16	30 (1.181)
6, 7	5/16	34 (1.339)
8, 9	7/16	38 (1.496)
10, 11	9/16, 1/4	42 (1.654)
12, 13, 14, 15, 16	3/8, 1/2, 5/8	50 (1.969)

Torque de sujeción - Tightening torque

Medida de portaherramienta (En pulgadas) Chuck size (Inch sizes)	Medida de portaherramientas (Medidas Métricas) Chuck size (Metric sizes)	Torque recomendado (Nm) Tightening torque (Nm)
PHC0250A~0312A	PHC06A~08A	11~12
PHC0375A~0750A	PHC09A~20A	7~8
PHC1000A, 1250A	PHC25A, 32A	29~30

$\square d$ Diámetro Interior de la Boquilla - Collet I.D.

$\square d1$ Número del Modelo - Model number

$\square d$	1/8	3/16	1/4	5/16	3/8	7/16	1/2	9/16	5/8
$\square d1$	0125	0187	0250	0312	0375	0438	0500	0562	0625

Para cortador con vena de refrigeración - For cutter with oil hole

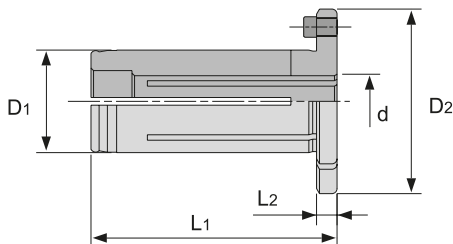

$\square D1$ Métrico - Metric, $\square d$ Métrico - Metric **Unidad : Métrico** Unit : Metric

Modelo / Model	D1	D2	L1	L2	$\square d$
PHS12- $\square d$ -OH	12	26	48	4	3, 4, 5, 6, 7, 8, 9, 10
PHS20- $\square d$ -OH	20	36	48	4	3, 4, 5, 6, 7, 8, 9, 10 11, 12, 13, 14, 15, 16

$\square D1$ Métrico - Metric, $\square d$ Pulgadas - Inch **Unidad : Pulgadas** Unit : Inch

Modelo / Model	D1	D2	L1	L2	$\square d$
PHS12- $\square d1$ -OH	0.472	1.024	1.890	0.158	1/8, 3/16, 1/4, 5/16, 3/8
PHS20- $\square d1$ -OH	0.787	1.418	1.890	0.158	1/8, 3/16, 1/4, 5/16, 3/8, 7/16, 1/2, 9/16, 5/8

$\square D1$ Pulgadas - Inch, $\square d$ Pulgadas - Inch **Unidad : Pulgadas** Unit : Inch

Modelo / Model	D1	D2	L1	L2	$\square d$
PHS0500- $\square d1$ -OH	0.500	1.024	1.890	1.158	1/8, 3/16, 1/4, 5/16, 3/8
PHS0750- $\square d1$ -OH	0.750	1.418	1.890	0.158	1/8, 3/16, 1/4, 5/16, 3/8, 7/16, 1/2, 9/16, 5/8

Ejemplo para Ordenar Para sostener herramienta de corte ϕ 6 con CAT40-PHC12A-105
Ordering Example To hold ϕ 6 cutting tool with BT40-PHC12A-120

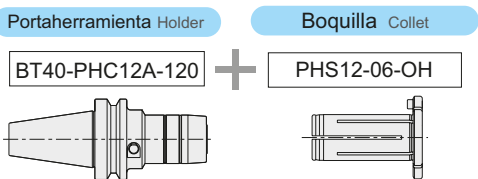

La boquilla con clavija de tope puede ser utilizada únicamente con PHC12A, PHC20A, PHC0500A y PHC0750A.

La boquilla con clavija de tope puede ser utilizada con la unidad de ajuste longitudinal.

The collet with stopper pin can be used with PHC12A, PHC20A, PHC0500A & PHC0750A only.

The collet with stopper pin can be used with the length adjustment unit.

Para boquilla con función de refrigeración por los costados - For collet through coolant

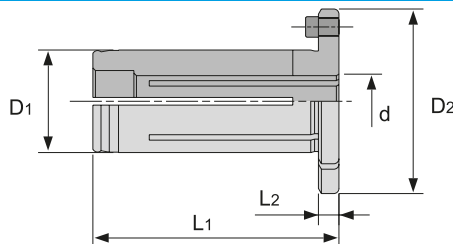

$\square D1$ Métrico - Metric, $\square d$ Métrico - Metric **Unidad : Métrico** Unit : Metric

Modelo / Model	D1	D2	L1	L2	$\square d$
PHS12- $\square d$ -C	12	26	48	4	3, 4, 5, 6, 7, 8, 9
PHS20- $\square d$ -C	20	36	48	4	3, 4, 5, 6, 7, 8, 9, 10 11, 12, 13, 14, 15, 16

$\square D1$ Métrico - Metric, $\square d$ Pulgadas - Inch **Unidad : Pulgadas** Unit : Inch

Modelo / Model	D1	D2	L1	L2	$\square d$
PHS12- $\square d1$ -C	0.472	1.024	1.890	0.158	1/8, 3/16, 1/4, 5/16, 3/8
PHS20- $\square d1$ -C	0.787	1.418	1.890	0.158	1/8, 3/16, 1/4, 5/16, 3/8, 7/16, 1/2, 9/16, 5/8

$\square D1$ Pulgadas - Inch, $\square d$ Pulgadas - Inch **Unidad : Pulgadas** Unit : Inch

Modelo / Model	D1	D2	L1	L2	$\square d$
PHS0500- $\square d1$ -C	0.500	1.024	1.890	1.158	1/8, 3/16, 1/4, 5/16, 3/8
PHS0750- $\square d1$ -C	0.750	1.418	1.890	0.158	1/8, 3/16, 1/4, 5/16, 3/8, 7/16, 1/2, 9/16, 5/8

Ejemplo para Ordenar Para Sostener una herramienta de corte de ϕ 6 utilizando la función de refrigeración por costados de la boquilla con BT40-PHC12A-120
Ordering Example To hold ϕ 6 cutting tool using collet through coolant feed with BT40-PHC12A-120

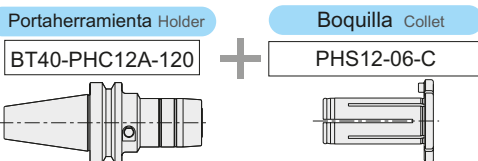

La boquilla con clavija de tope puede ser utilizada únicamente con PHC12A y PHC20A, PHC0500A y PHC0750A.

La boquilla con clavija de tope puede ser utilizada con la unidad de ajuste de longitud.

The collet with stopper pin can be used with PHC12A, PHC20A, PHC0500A & PHC0750A only.

The collet with stopper pin can be used with the length adjustment unit.

Pulgada a métrico → Pulgada × 25.4

Métrico a pulgada → Métrico ÷ 25.4 ó métrico por 0.03937



Tamaños especiales / personalizados bajo pedido

BT
CAT
AHO
HSK-A/E/F/C
C
UTS
Máquinas Especializadas
Specialized Machine
Equipo Relacionado
Related Equipment
Taladro de Biselado & Casquillo
Bush & Chamfering Drill
Milling Chuck
Collet Holder
"R" Zero Holder
Hydraulic Chuck
Shrink Fit
Tapping Chuck
Ahoros
Function Holder
Turning Tool
Retention Stud
Tool Shank Dimensions

PHC · SA-C

Nuevo

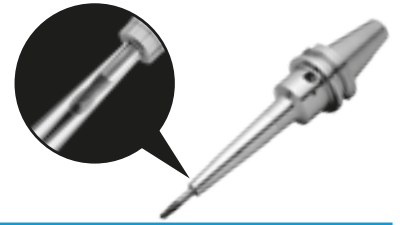

Portaherramienta Hidráulico Delgado

Slim Hydro Chuck Blaster (For side through coolant)

- La opción perfecta para trabajos en espacios reducidos, tales como acabados en fresado, barrenado y rimado en máquinas de 5-ejes.
- Perfect choice for tight space applications, such as endmill finishing, drilling and reaming on 5-axis machines.

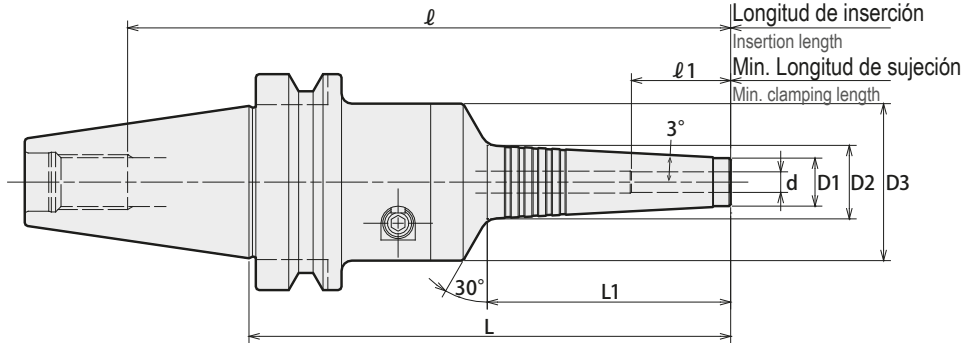

Código Code	Modelo Model	d	L	L1	D1	D2	D3	ℓ	ℓ1	Max min ⁻¹	Kg	Llave Allen (Opcional) Wrench (Option)	
3950 01103085	BT30 -PHC03SA -85 -C	3	85	30	12	15.2	46	(108)	18	38,000	0.6	L-4T	
3950 01103130	-130 -C	3	130	71	12	19.5	46	(158)	18	23,000	0.9		
3950 01104085	-PHC04SA -85 -C	4	85	30	12	15.2	46	(108)	24	38,000	0.6		
3950 01104130	-130 -C	4	130	71	12	19.5	46	(158)	24	22,000	0.9		
3950 01106090	-PHC06SA -90 -C	6	90	26	14	16.8	46	(113)	29	30,000	0.9		
3950 01106135	-135 -C	6	135	71	14	21.5	46	(158)	29	21,000	1.0		
3950 01108090	-PHC08SA -90 -C	8	90	27	16	18.9	46	(113)	29	27,000	0.9		
3950 01108135	-135 -C	8	135	72	16	23.6	46	(158)	29	20,000	1.0		
3950 01110090	-PHC10SA -90 -C	10	90	32	18	21.4	46	70	40	27,000	0.8		
3950 01110135	-135 -C	10	135	72	18	25.6	46	100	40	20,000	1.0		
3950 01112090	-PHC12SA -90 -C	12	90	33	20	23.5	46	70	40	26,000	0.8		
3950 01112135	-135 -C	12	135	73	20	27.7	46	100	40	19,000	1.0		
3950 01303090	BT40 -PHC03SA -90 -C	3	90	30	12	15.2	46	(125)	18	20,000	1.1	L-4T	
3950 01303135	-135 -C	3	135	71	12	19.5	46	(170)	18	20,000	1.5		
3950 01304090	-PHC04SA -90 -C	4	90	30	12	15.2	46	(125)	24	20,000	1.1		
3950 01304135	-135 -C	4	135	71	12	19.5	46	(170)	24	20,000	1.5		
3950 01306090	-PHC06SA -90 -C	6	90	26	14	16.8	46	(125)	29	20,000	1.4		
3950 01306135	-135 -C	6	135	71	14	21.5	46	(170)	29	20,000	1.5		
3950 01308090	-PHC08SA -90 -C	8	90	27	16	18.9	46	(125)	29	20,000	1.4		
3950 01308135	-135 -C	8	135	72	16	23.6	46	(170)	29	20,000	1.5		
3950 01310090	-PHC10SA -90 -C	10	90	32	18	21.4	46	(125)	40	20,000	1.4		
3950 01310135	-135 -C	10	135	72	18	25.6	46	(170)	40	20,000	1.5		
3950 01312090	-PHC12SA -90 -C	12	90	33	20	23.5	46	(125)	40	20,000	1.4		
3950 01312135	-135 -C	12	135	73	20	27.7	46	(170)	40	20,000	1.5		
3950 01316135	-PHC16SA -135 -C	16	135	72	24	31.6	52.5	90	40	20,000	1.7	L-6T	
3950 01316165	-165 -C	16	165	103	24	34.8	52.5	120	40	13,000	1.9		
3950 01320135	-PHC20SA -135 -C	20	135	63	29	35.7	62	85	40	18,000	2.2		
3950 01320180	-180 -C	20	180	109	29	40.5	62	130	40	12,000	2.5		
3950 01325135	-PHC25SA -135 -C	25	135	65	38	44.9	62	85	50	16,000	2.2		
3950 01325180	-180 -C	25	180	112	38	49.8	62	130	50	11,000	2.6		
3950 01506150	BT50 -PHC06SA -150 -C	6	150	71	14	21.5	46	(206)	29	15,000	4.1	L-4T	
3950 01506195	-195 -C	6	195	118	14	26.4	46	(251)	29	10,000	4.2		
3950 01508150	-PHC08SA -150 -C	8	150	72	16	23.6	46	(206)	29	15,000	4.1		
3950 01508195	-195 -C	8	195	118	16	28.4	46	(251)	29	10,000	4.2		
3950 01510150	-PHC10SA -150 -C	10	150	72	18	25.6	46	(206)	40	15,000	4.1		
3950 01510195	-195 -C	10	195	119	18	30.5	46	(251)	40	10,000	4.3		
3950 01512150	-PHC12SA -150 -C	12	150	73	20	27.7	46	(206)	40	15,000	4.1		
3950 01512195	-195 -C	12	195	119	20	32.5	46	(251)	40	10,000	4.3		
3950 01516165	-PHC16SA -150 -C	16	150	72	24	31.6	52.5	90	40	15,000	4.2		
3950 01516195	-195 -C	16	195	119	24	36.5	52.5	135	40	10,000	4.6		
3950 01520165	-PHC20SA -150 -C	20	150	63	29	35.7	62	85	40	15,000	4.7		L-6T
3950 01520195	-195 -C	20	195	109	29	40.5	62	130	40	12,000	5.0		
3950 01525165	-PHC25SA -150 -C	25	150	65	38	44.9	62	85	50	15,000	4.8		
3950 01525195	-195 -C	25	195	112	38	49.8	62	130	50	12,000	5.2		

- La tolerancia del diámetro de zanco de la herramienta debe estar dentro de h6.
- El tornillo Allen opresor es necesario para tapar el orificio de aire para habilitar la alimentación de refrigeración por centro de la herramienta.
- La velocidad permitida varía mucho según la rigidez del husillo en la máquina y del balance de la herramienta de corte.
Aumente gradualmente la velocidad a partir de la baja y úselo en la velocidad adecuada.
- Las medidas de ℓ mostradas entre parentesis corresponden a la superficie del perno de retención

- Tool shank diameter tolerance must be within h6.
- Hex-head screws are necessary to plug air hole for center through coolant feed.
- Permissible speed is greatly affected by the stiffness of the machine spindle and the balance of the cutting tool. Gradually increase from a low speed, and use at the proper speed.
- The ℓ dimensions shown in () measure to the end surface of the retention stud.

Ejemplo para Ordenar - Ordering Example

BT50 - PHC 12 SA- 150 - C

Interfaz y diámetro de husillo

Diámetro Interior

Longitud de proyección

Shank size

I.D.

Projection length

Llave Allen Hex. Wrench

Tornillo de retención Preset Screw

Pág. 099

Pág. 120

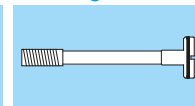

Portaherramienta Hidráulico delgado

Slim Hydro Chuck Blaster (With cap)

● Efectivo en trabajos de espacios reducidos

Perfect choice for tight space applications, such as endmill finishing, drilling and reaming on 5-axis machines.

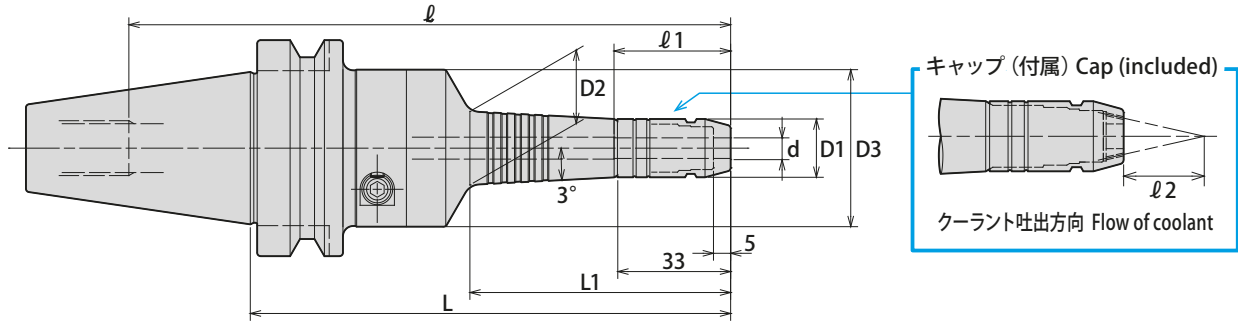

Código Code	Modelo Model	d	L	L1	D1	D2	D3	l	l1	l2	Max min ⁻¹	Kg	Llave Allen Wrench(Option)
3950 05104135	BT30 -PHC04SA -135-NC	4	135	76	15	19.5	46	(158)	29	20	22,000	0.9	L-4T
3950 05106140	-PHC06SA -140-NC	6	140	76	17	21.5	46	(163)	34	30	21,000	1.0	
3950 05108140	-PHC08SA -140-NC	8	140	77	19	23.6	46	(163)	34	40	20,000	1.0	
3950 05110095	-PHC10SA -95-NC	10	95	37	21	21.4	46	75	45	50	27,000	0.87	
3950 05110140	-140-NC	10	140	77	21	25.6	46	105	45	50	20,000	1.0	
3950 05112095	-PHC12SA -95-NC	12	95	38	23	23.5	46	75	45	60	26,000	0.8	
3950 05112140	-140-NC	12	140	78	23	27.7	46	105	45	60	19,000	1.0	L-4T
3950 05304140	BT40 -PHC04SA -140-NC	4	140	76	15	19.5	46	(175)	29	20	20,000	1.5	
3950 05306140	-PHC06SA -140-NC	6	140	76	17	21.5	46	(175)	34	30	20,000	1.5	
3950 05308140	-PHC08SA -140-NC	8	140	77	19	23.6	46	(175)	34	40	20,000	1.5	
3950 05310095	-PHC10SA -95-NC	10	95	37	21	21.4	46	(130)	45	50	20,000	1.4	
3950 05310140	-140-NC	10	140	77	21	25.6	46	(175)	45	50	20,000	1.5	
3950 05312095	-PHC12SA -95-NC	12	95	38	23	23.5	46	(130)	45	60	20,000	1.4	L-4T
3950 05312140	-140-NC	12	140	78	23	27.7	46	(175)	45	60	20,000	1.5	
3950 05506155	BT50 -PHC06SA -155-NC	6	155	76	17	21.5	46	(211)	34	30	15,000	4.1	
3950 05506200	-200-NC	6	200	123	17	26.4	46	(256)	34	30	10,000	4.2	
3950 05508155	-PHC08SA -155-NC	8	155	77	19	23.6	46	(211)	34	40	15,000	4.1	
3950 05508200	-200-NC	8	200	123	19	28.4	46	(256)	34	40	10,000	4.2	
3950 05510155	-PHC10SA -155-NC	10	155	77	21	25.6	46	(211)	45	50	15,000	4.1	L-4T
3950 05510200	-200-NC	10	200	124	21	30.5	46	(256)	45	50	10,000	4.3	
3950 05512155	-PHC12SA -155-NC	12	155	78	23	27.7	46	(211)	45	60	15,000	4.1	
3950 05512200	-200-NC	12	200	124	23	32.5	46	(256)	45	60	10,000	4.3	

1. La tolerancia del diámetro de zanco de la herramienta debe estar dentro de h6.
 2. El tornillo Allen opresor es necesario para taponar el orificio de aire para habilitar la alimentación de refrigeración por centro de la herramienta.
 3. La velocidad permitida varía mucho según la rigidez del husillo en la máquina y del balance de la herramienta de corte. Aumente gradualmente la velocidad a partir de la baja y úselo en la velocidad adecuada.
 4. ℓ indica la dimensión al usarlo con un tornillo de preajuste.
() la medida se encuentra al final del perno de retención.
1. Tool shank diameter tolerance must be within h6.
 2. Hex-head screws are necessary to plug air hole for center through coolant feed.
 3. Permissible speed is greatly affected by the stiffness of the machine spindle and the balance of the cutting tool. Gradually increase from a low speed, and use at the proper speed.
 4. ℓ indicates dimension when using without a preset screw.
() dimension is to end of retention stud.

Ejemplo para Ordenar - Ordering Example

BT50 -PHC 12 SA- 140 -NC

Interfaz y diámetro de husillo

Shank size

Diámetro Interior

I.D.

Longitud de proyección

Projection length

Llave Allen
Hex. wrench

Pág. 099



Tornillo de preajuste
Preset Screw

Pág. 120

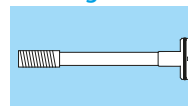

Tapa tipo boquilla
Cap

Pág. 117

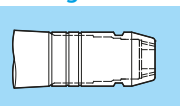

Tapa tipo boquilla para PHC•SA-NC / Cap for PHC•SA-NC

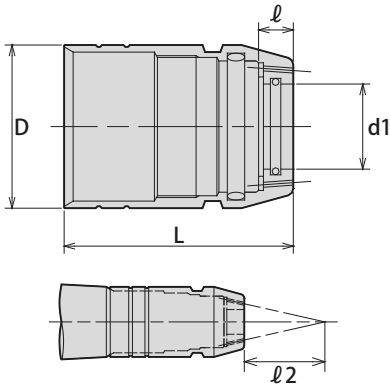

クーラント吐出方向 Flow of coolant

Código Code	Modelo Model	Portaherramienta correspondiente Matched chuck size	d1	D	L	ℓ	ℓ2
3954 05010004	CP-PHC04SA-NC	PHC04SA-NC	4	15	33	5	20
3954 05010006	CP-PHC06SA-NC	PHC06SA-NC	6	17	33	5	30
3954 05010008	CP-PHC08SA-NC	PHC08SA-NC	8	19	33	5	40
3954 05010010	CP-PHC10SA-NC	PHC10SA-NC	10	21	33	5	50
3954 05010012	CP-PHC12SA-NC	PHC12SA-NC	12	23	33	5	60
3954 06010006	CP-PHC0250SA-NC	PHC0250SA-NC	6.35	17	33	5	30
3954 06010008	CP-PHC0312SA-NC	PHC0312SA-NC	7.93	19	33	5	40
3954 06010010	CP-PHC0375SA-NC	PHC0375SA-NC	9.53	21	33	5	50
3954 06010012	CP-PHC0500SA-NC	PHC0500SA-NC	12.7	23	33	5	60

Ejemplo para Ordenar - Ordering Example

CP - PHC04SA - NC

Tamaño del portaherramienta Holder size

Tapa tipo boquilla para PHC•SA-NC / Cap for PHC•SA-NC

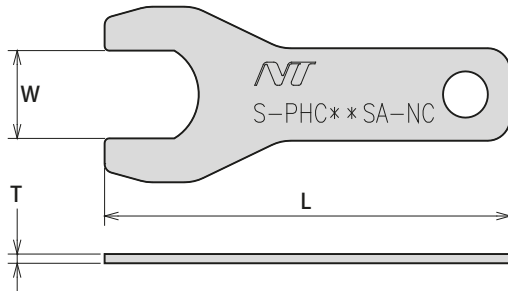

Código Code	Modelo Model	W	L	T
3954 05020004	S-PHC04SA-NC	13	77.5	2
3954 05020006	S-PHC06SA-NC	15	83.5	2
3954 05020008	S-PHC08SA-NC	17	89.5	2
3954 05020010	S-PHC10SA-NC	19	90.5	2
3954 05020012	S-PHC12SA-NC	21	91.5	3
3954 06020012	S-PHC0500SA-NC	22	91.5	3

Ejemplo para Ordenar - Ordering Example

S - PHC04SA - NC

Tamaño del portaherramienta Holder size



Portaherramienta Hidráulico Delgado

Slim Hydro Chuck

- La opción perfecta para trabajos en espacios reducidos, tales como acabados en fresado, barrenado y rimado en máquinas de 5-ejes
- Perfect choice for tight space applications, such as endmill finishing, drilling and reaming on 5-axis machines.

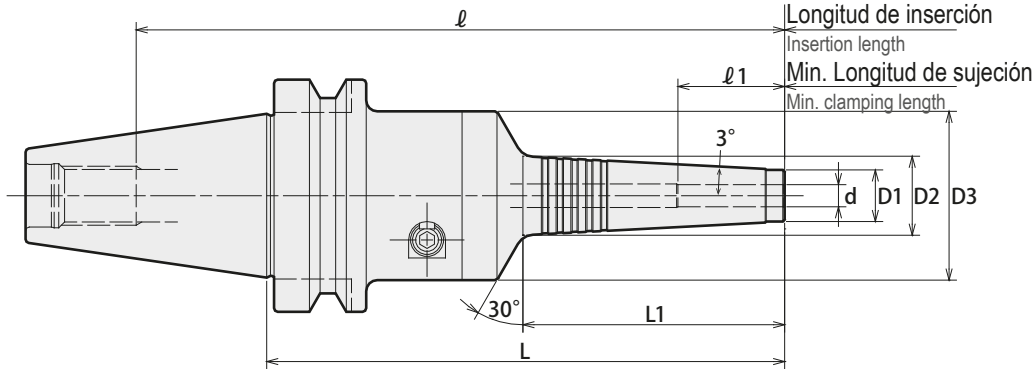

	Código Code	Modelo Model	d	L	L1	D1	D2	D3	ℓ	ℓ1	Max min ⁻¹	Kg	Llave Allen (Opcional) Wrench (Option)
Milling Chuck	3700 01103070	BT30 -PHC03SA -70	3	70	19	11	13.0	46	(93)	18	40,000	0.6	L-4T
	3700 01103085	-85	3	85	30	11	14.2	46	(108)	18	38,000	0.6	
	3700 01103130	-130	3	130	71	11	18.5	46	(158)	18	23,000	0.9	
Collet Holder	3700 01104070	-PHC04SA -70	4	70	19	11	13.0	46	(93)	24	40,000	0.6	
	3700 01104085	-85	4	85	30	11	14.2	46	(108)	24	38,000	0.6	
	3700 01104130	-130	4	130	71	11	18.5	46	(158)	24	22,000	0.9	
"R" Zero Holder	3700 01106090	-PHC06SA -90	6	90	26	13	15.8	46	(113)	29	30,000	0.9	
	3700 01106135	-135	6	135	71	13	20.5	46	(158)	29	21,000	1.0	
	3700 01106150	-150	6	150	87	13	22.2	46	(173)	29	15,000	1.0	
Hydraulic Chuck	3700 01106165	-165	6	165	102	13	23.7	46	(188)	29	12,000	1.1	
	3700 01106180	-180	6	180	118	13	25.4	46	(203)	29	10,000	1.1	
	3700 01107090	-PHC07SA -90	7	90	26	14	16.8	46	(113)	29	28,000	0.9	
Shrink Fit	3700 01107135	-135	7	135	71	14	21.5	46	(158)	29	21,000	1.0	
	3700 01107150	-150	7	150	87	14	23.2	46	(173)	29	15,000	1.0	
	3700 01107165	-165	7	165	102	14	24.7	46	(188)	29	12,000	1.1	
Tapping Chuck	3700 01107180	-180	7	180	118	14	26.4	46	(203)	29	10,000	1.1	
	3700 01108090	-PHC08SA -90	8	90	27	15	17.9	46	(113)	29	27,000	0.9	
	3700 01108135	-135	8	135	72	15	22.6	46	(158)	29	20,000	1.0	
Anchors	3700 01108150	-150	8	150	87	15	24.2	46	(173)	29	15,000	1.0	
	3700 01108165	-165	8	165	103	15	25.8	46	(188)	29	12,000	1.1	
	3700 01108180	-180	8	180	118	15	27.4	46	(203)	29	10,000	1.2	
Function Holder	3700 01109090	-PHC09SA -90	9	90	32	16	19.4	46	(113)	40	27,000	0.8	
	3700 01109135	-135	9	135	72	16	23.6	46	(158)	40	20,000	1.0	
	3700 01109150	-150	9	150	87	16	25.2	46	(173)	40	15,000	1.1	
Turning Tool	3700 01109165	-165	9	165	103	16	26.8	46	(188)	40	12,000	1.1	
	3700 01109180	-180	9	180	118	16	28.4	46	(203)	40	10,000	1.2	
	3700 01110090	-PHC10SA -90	10	90	32	17	20.4	46	70	40	27,000	0.8	
Retention Stud	3700 01110135	-135	10	135	72	17	24.6	46	100	40	20,000	1.0	
	3700 01110150	-150	10	150	87	17	26.3	46	115	40	15,000	1.1	
	3700 01110165	-165	10	165	103	17	27.8	46	130	40	12,000	1.1	
Tool Shank Dimensions	3700 01110180	-180	10	180	119	17	29.5	46	145	40	10,000	1.2	
	3700 01111090	-PHC11SA -90	11	90	33	18	21.5	46	70	40	26,000	0.8	
	3700 01111135	-135	11	135	73	18	25.7	46	100	40	19,000	1.0	
Tool Shank Dimensions	3700 01111150	-150	11	150	88	18	27.3	46	115	40	15,000	1.1	
	3700 01111165	-165	11	165	104	18	29.0	46	130	40	12,000	1.2	
	3700 01111180	-180	11	180	119	18	30.5	46	145	40	10,000	1.2	
Turning Tool	3700 01112090	-PHC12SA -90	12	90	33	19	22.5	46	70	40	26,000	0.8	
	3700 01112135	-135	12	135	73	19	26.7	46	100	40	19,000	1.0	
	3700 01112150	-150	12	150	88	19	28.3	46	115	40	15,000	1.1	
Retention Stud	3700 01112165	-165	12	165	104	19	30.0	46	130	40	12,000	1.2	
	3700 01112180	-180	12	180	119	19	31.5	46	145	40	10,000	1.2	
	3700 01303075	BT40 -PHC03SA -75	3	75	19	11	13.0	46	(110)	18	20,000	1.1	L-4T
3700 01303090	-90	3	90	30	11	14.2	46	(125)	18	20,000	1.1		
3700 01303135	-135	3	135	71	11	18.5	46	(170)	18	20,000	1.5		
Turning Tool	3700 01304075	-PHC04SA -75	4	75	19	11	13.0	46	(110)	24	20,000	1.1	
	3700 01304090	-90	4	90	30	11	14.2	46	(125)	24	20,000	1.1	
	3700 01304135	-135	4	135	71	11	18.5	46	(170)	24	20,000	1.5	
Retention Stud	3700 01306090	-PHC06SA -90	6	90	26	13	15.8	46	(125)	29	20,000	1.4	
	3700 01306135	-135	6	135	71	13	20.5	46	(170)	29	20,000	1.5	
	3700 01306150	-150	6	150	87	13	22.2	46	(185)	29	16,000	1.5	
Tool Shank Dimensions	3700 01306165	-165	6	165	102	13	23.7	46	(200)	29	12,000	1.6	
	3700 01306180	-180	6	180	118	13	25.4	46	(215)	29	10,000	1.6	
	3700 01307090	-PHC07SA -90	7	90	26	14	16.8	46	(125)	29	20,000	1.4	
Tool Shank Dimensions	3700 01307135	-135	7	135	71	14	21.5	46	(170)	29	20,000	1.5	
	3700 01307150	-150	7	150	87	14	23.2	46	(185)	29	16,000	1.5	
	3700 01307165	-165	7	165	102	14	24.7	46	(200)	29	13,000	1.6	
3700 01307180	-180	7	180	118	14	26.4	46	(215)	29	10,000	1.6		

Código Code	Modelo Model	d	L	L1	D1	D2	D3	ℓ	ℓ1	Max min ⁻¹	Kg	Llave Allen (Opcional) Wrench(Option)	
3700 01308090	-PHC08SA	-90	8	90	27	15	17.9	46	(125)	29	20,000	1.4	L-4T
3700 01308135	-135	8	135	72	15	22.6	46	(170)	29	20,000	1.5		
3700 01308150	-150	8	150	87	15	24.2	46	(185)	29	17,000	1.5		
3700 01308165	-165	8	165	103	15	25.8	46	(200)	29	12,000	1.6		
3700 01308180	-180	8	180	118	15	27.4	46	(215)	29	10,000	1.7		
3700 01309090	-PHC09SA	-90	9	90	32	16	19.4	46	(125)	40	20,000	1.4	
3700 01309135	-135	9	135	72	16	23.6	46	(170)	40	20,000	1.5		
3700 01309150	-150	9	150	87	16	25.2	46	(185)	40	16,000	1.6		
3700 01309165	-165	9	165	103	16	26.8	46	(200)	40	12,000	1.6		
3700 01309180	-180	9	180	118	16	28.4	46	(215)	40	10,000	1.7		
3700 01310090	-PHC10SA	-90	10	90	32	17	20.4	46	(125)	40	20,000	1.4	
3700 01310135	-135	10	135	72	17	24.6	46	(170)	40	20,000	1.5		
3700 01310150	-150	10	150	87	17	26.3	46	(185)	40	16,000	1.6		
3700 01310165	-165	10	165	103	17	27.8	46	(200)	40	12,000	1.6		
3700 01310180	-180	10	180	119	17	29.5	46	(215)	40	10,000	1.7		
3700 01311090	-PHC11SA	-90	11	90	33	18	21.5	46	(125)	40	20,000	1.4	
3700 01311135	-135	11	135	73	18	25.7	46	(170)	40	20,000	1.5		
3700 01311150	-150	11	150	88	18	27.3	46	(185)	40	15,000	1.6		
3700 01311165	-165	11	165	104	18	29.0	46	(200)	40	12,000	1.7		
3700 01311180	-180	11	180	119	18	30.5	46	(215)	40	10,000	1.7		
3700 01312090	-PHC12SA	-90	12	90	33	19	22.5	46	(125)	40	20,000	1.4	
3700 01312135	-135	12	135	73	19	26.7	46	(170)	40	20,000	1.5		
3700 01312150	-150	12	150	88	19	28.3	46	(185)	40	15,000	1.6		
3700 01312165	-165	12	165	104	19	30.0	46	(200)	40	12,000	1.7		
3700 01312180	-180	12	180	119	19	31.5	46	(215)	40	10,000	1.8		
3700 01316135	-PHC16SA	-135	16	135	72	23	30.6	52.5	90	40	20,000	1.7	
3700 01316165	-165	16	165	103	23	33.8	52.5	120	40	13,000	1.9		
3700 01316180	-180	16	180	119	23	35.5	52.5	135	40	10,000	2.0		
3700 01320135	-PHC20SA	-135	20	135	63	28	34.7	62	85	40	18,000	2.2	
3700 01320165	-165	20	165	93	28	37.8	62	115	40	14,000	2.3		
3700 01320180	-180	20	180	109	28	39.5	62	130	40	12,000	2.5		
3700 01325135	-PHC25SA	-135	25	135	65	37	43.9	62	85	50	16,000	2.2	
3700 01325165	-165	25	165	96	37	47.1	62	115	50	15,000	2.5		
3700 01325180	-180	25	180	112	37	48.8	62	130	50	11,000	2.6		
3700 01506105	BT50 -PHC06SA	-105	6	105	26	13	15.8	46	(161)	29	15,000	4.1	
3700 01506150	-150	6	150	71	13	20.5	46	(206)	29	15,000	4.1		
3700 01506165	-165	6	165	87	13	22.2	46	(221)	29	15,000	4.1		
3700 01506180	-180	6	180	102	13	23.7	46	(236)	29	12,000	4.2		
3700 01506195	-195	6	195	118	13	25.4	46	(251)	29	10,000	4.2		
3700 01507105	-PHC07SA	-105	7	105	26	14	16.8	46	(161)	29	15,000	4.1	
3700 01507150	-150	7	150	71	14	21.5	46	(206)	29	15,000	4.1		
3700 01507165	-165	7	165	87	14	23.2	46	(221)	29	15,000	4.1		
3700 01507180	-180	7	180	102	14	24.7	46	(236)	29	12,000	4.2		
3700 01507195	-195	7	195	118	14	26.4	46	(251)	29	10,000	4.2		
3700 01508105	-PHC08SA	-105	8	105	27	15	17.9	46	(161)	29	15,000	4.1	
3700 01508150	-150	8	150	72	15	22.6	46	(206)	29	15,000	4.1		
3700 01508165	-165	8	165	87	15	24.2	46	(221)	29	15,000	4.1		
3700 01508180	-180	8	180	103	15	25.8	46	(236)	29	12,000	4.2		
3700 01508195	-195	8	195	118	15	27.4	46	(251)	29	10,000	4.2		
3700 01509150	-PHC09SA	-150	9	150	72	16	23.6	46	(206)	40	15,000	4.1	
3700 01509165	-165	9	165	87	16	25.2	46	(221)	40	15,000	4.1		
3700 01509180	-180	9	180	103	16	26.8	46	(236)	40	12,000	4.2		
3700 01509195	-195	9	195	118	16	28.4	46	(251)	40	10,000	4.3		
3700 01510150	-PHC10SA	-150	10	150	72	17	24.6	46	(206)	40	15,000	4.1	
3700 01510165	-165	10	165	87	17	26.3	46	(221)	40	15,000	4.2		
3700 01510180	-180	10	180	103	17	27.8	46	(236)	40	12,000	4.2		
3700 01510195	-195	10	195	119	17	29.5	46	(251)	40	10,000	4.3		
3700 01511150	-PHC11SA	-150	11	150	73	18	25.7	46	(206)	40	15,000	4.1	
3700 01511165	-165	11	165	88	18	27.3	46	(221)	40	15,000	4.2		
3700 01511180	-180	11	180	104	18	29.0	46	(236)	40	12,000	4.2		
3700 01511195	-195	11	195	119	18	30.5	46	(251)	40	10,000	4.3		
3700 01512150	-PHC12SA	-150	12	150	73	19	26.7	46	(206)	40	15,000	4.1	
3700 01512165	-165	12	165	88	19	28.3	46	(221)	40	15,000	4.2		
3700 01512180	-180	12	180	104	19	30.0	46	(236)	40	12,000	4.3		
3700 01512195	-195	12	195	119	19	31.5	46	(251)	40	10,000	4.3		
3700 01516150	-PHC16SA	-150	16	150	72	23	30.6	52.5	90	40	15,000	4.2	
3700 01516180	-180	16	180	103	23	33.8	52.5	120	40	12,000	4.4		
3700 01516195	-195	16	195	119	23	35.5	52.5	135	40	10,000	4.6		
3700 01520150	-PHC20SA	-150	20	150	63	28	34.7	62	85	40	15,000	4.7	
3700 01520180	-180	20	180	93	28	37.8	62	115	40	14,000	4.9		
3700 01520195	-195	20	195	109	28	39.5	62	130	40	12,000	5.0		
3700 01525150	-PHC25SA	-150	25	150	65	37	43.9	62	85	50	15,000	4.8	
3700 01525180	-180	25	180	96	37	47.1	62	115	50	14,000	5.0		
3700 01525195	-195	25	195	112	37	48.8	62	130	50	12,000	5.2		

BT
CAT

AHO
HSK-A/E/F/C
HSK-T

C
UTS

Máquinas Especializadas
Specialized Machine

Equipo Relacionado
Related Equipment

Taladro de Biselado & Casquillo
Burr & Chamfering Drill

Milling Chuck

Collet Holder

"R" Zero Holder

Hydraulic Chuck

Shrink Fit

Tapping Chuck

Arbors

Function Holder

Retention Stud

Turning Tool

Retention Stud

Tool Shank Dimensions

- La tolerancia del diámetro de zanco de la herramienta debe estar dentro de h6.
- El tornillo Allen es necesario para tapan el orificio de aire para habilitar la alimentación de refrigeración por centro de la boquilla.
- La velocidad permitida se ve afectada por la rigidez del husillo de la máquina y el balance de la herramienta de corte. Incrementar gradualmente de una velocidad lenta, hasta llegar a la velocidad adecuada.
- Las medidas de ℓ mostradas entre parentesis corresponden a la superficie del perno de retención
 - Tool shank diameter tolerance must be within h6.
 - Hex-head screws are necessary to plug air hole for center through coolant feed.
 - Permissible speed is greatly affected by the stiffness of the machine spindle and the balance of the cutting tool. Gradually increase from a low speed, and use at the proper speed.
 - The ℓ dimensions shown in () measure to the end surface of the retention stud.

Torque de sujeción (Llave Allen : pág. 520) Tightening torque (Llave de Torque : P.520)		
Modelo Model	I.D. (d) mm	Torque de sujeción Tightening torque (Nm)
PHC-S	06 ~ 12, 16	9 ~ 10
PHC-S	20 ~ 25	23 ~ 24

Llave Allen Hex. Wrench
Pág. 099

Ejemplo para Ordenar - Ordering Example
BT50 -PHC 12 SA- 150

Interfaz y diámetro del husillo Shank size
Diámetro Interior I.D.
Longitud de proyección Projection length

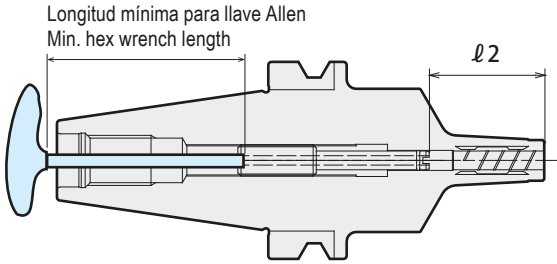

Tipo1
Type1

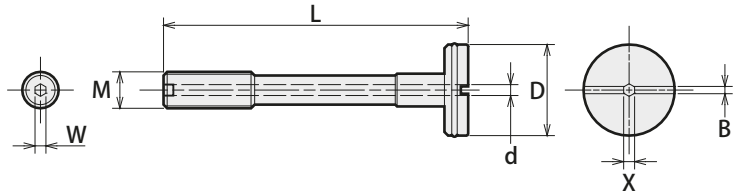

Tipo2
Type2

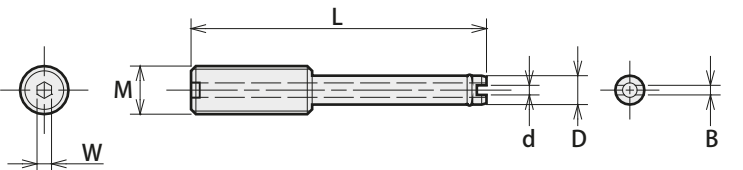

Interfaz y diámetro de husillo Shank size	Longitud mínima para llave Allen Min. hex wrench length
BT30	73mm
BT40	90mm
BT50	141mm

Tornillo de preajuste preset screw		Portaherramienta correspondiente Matched chuck	Rango de ajuste Adjustment range l_2	Cantidad de ajuste Adjustment amount	Tipo Type	W	X	B	D	d	L	M		
Código Code	Modelo Model													
3704 00040121	PHCSA -P04 -012A	BT30 -PHC03SA	-70	18~49	31	2	2.5	-	1	4	2	27	M5 P=0.8	
3704 00040141	PHCSA -P04 -014A		-85	18~49	31	2	2.5	-	1	4	2	37		
3704 00040161	PHCSA -P04 -016A		-130	18~49	31	2	2.5	-	1	4	2	82		
3704 00040111	PHCSA -P04 -011A	-PHC04SA	-70	24~55	31	2	2.5	-	1	4	2	21		
3704 00040131	PHCSA -P04 -013A		-85	24~55	31	2	2.5	-	1	4	2	31		
3704 00040151	PHCSA -P04 -015A		-130	24~55	31	2	2.5	-	1	4	2	76		
3704 00060210	PHCSA -P06 -021	-PHC06SA	-90	29~74	45	2	3	-	2	6	3	40		M10 P=1
3704 00060220	PHCSA -P06 -022		-135	29~58	29	2	3	-	2	6	3	101		
3704 00060220	PHCSA -P06 -022		-150	29~73	44	2	3	-	2	6	3	101		
3704 00060230	PHCSA -P06 -023	-165	29~58	29	2	3	-	2	6	3	131			
3704 00060230	PHCSA -P06 -023	-180	29~73	44	2	3	-	2	6	3	131			
3704 00060210	PHCSA -P06 -021	-PHC07SA	-90	29~74	45	2	3	-	2	6	3	40		
3704 00070220	PHCSA -P07 -022		-135	29~58	29	2	3	-	2	7	3	101		
3704 00070220	PHCSA -P07 -022		-150	29~73	44	2	3	-	2	7	3	101		
3704 00070230	PHCSA -P07 -023	-165	29~58	29	2	3	-	2	7	3	131			
3704 00070230	PHCSA -P07 -023	-180	29~73	44	2	3	-	2	7	3	131			
3704 00060210	PHCSA -P06 -021	-PHC08SA	-90	29~74	45	2	3	-	2	6	3	40	M5 P=0.8	
3704 00080220	PHCSA -P08 -022		-135	29~58	29	2	3	-	2	8	3	101		
3704 00080220	PHCSA -P08 -022		-150	29~73	44	2	3	-	2	8	3	101		
3704 00080230	PHCSA -P08 -023	-165	29~58	29	2	3	-	2	8	3	131			
3704 00080230	PHCSA -P08 -023	-180	29~73	44	2	3	-	2	8	3	131			
3704 00090210	PHCSA -P09 -021	-PHC09SA	-90	40~74	34	2	3	3	2	9	3	40		
3704 00090220	PHCSA -P09 -022		-135	40~69	29	2	3	3	2	9	3	90		
3704 00090220	PHCSA -P09 -022		-150	40~84	44	2	3	3	2	9	3	90		
3704 00090230	PHCSA -P09 -023	-165	40~69	29	2	3	3	2	9	3	120			
3704 00090230	PHCSA -P09 -023	-180	40~84	44	2	3	3	2	9	3	120			
3704 00090210	PHCSA -P09 -021	-PHC10SA	-90	40~70	30	1	3	3	2	9	3	40	M5 P=0.8	
3704 00100220	PHCSA -P10 -022		-135	40~69	29	1	3	3	2	10	3	90		
3704 00100220	PHCSA -P10 -022		-150	40~84	44	1	3	3	2	10	3	90		
3704 00100230	PHCSA -P10 -023	-165	40~69	29	1	3	3	2	10	3	120			
3704 00100230	PHCSA -P10 -023	-180	40~84	44	1	3	3	2	10	3	120			
3704 00090210	PHCSA -P09 -021	-PHC11SA	-90	40~70	30	1	3	3	2	9	3	40		
3704 00110220	PHCSA -P11 -022		-135	40~69	29	1	3	3	2	11	3	90		
3704 00110220	PHCSA -P11 -022		-150	40~84	44	1	3	3	2	11	3	90		
3704 00110230	PHCSA -P11 -023	-165	40~69	29	1	3	3	2	11	3	120			
3704 00110230	PHCSA -P11 -023	-180	40~84	44	1	3	3	2	11	3	120			
3704 00090210	PHCSA -P09 -021	-PHC12SA	-90	40~70	30	1	3	3	2	9	3	40	M5 P=0.8	
3704 00120220	PHCSA -P12 -022		-135	40~69	29	1	3	3	2	12	3	90		
3704 00120220	PHCSA -P12 -022		-150	40~84	44	1	3	3	2	12	3	90		
3704 00120230	PHCSA -P12 -023	-165	40~69	29	1	3	3	2	12	3	120			
3704 00120230	PHCSA -P12 -023	-180	40~84	44	1	3	3	2	12	3	120			
3704 00040121	PHCSA -P04 -012A	BT40 -PHC03SA	-75	18~49	31	2	2.5	-	1	4	2	27		M5 P=0.8
3704 00040141	PHCSA -P04 -014A		-90	18~49	31	2	2.5	-	1	4	2	37		
3704 00040161	PHCSA -P04 -016A		-135	18~49	31	2	2.5	-	1	4	2	82		
3704 00040111	PHCSA -P04 -011A	-PHC04SA	-75	24~55	31	2	2.5	-	1	4	2	21		
3704 00040131	PHCSA -P04 -013A		-90	24~55	31	2	2.5	-	1	4	2	31		
3704 00040151	PHCSA -P04 -015A		-135	24~55	31	2	2.5	-	1	4	2	76		

Tornillo de preajuste preset screw		Portaherramienta correspondiente Matched chuck	Rango de ajuste Adjustment range ℓ2	Cantidad de ajuste Adjustment amount	Tipo Type	W	X	B	D	d	L	M
Código Code	Modelo Model											
3704 00060210	PHCSA -P06 -021	BT40 -PHC06SA -90	29~85	56	2	3	-	2	6	3	40	M10 P=1
3704 00060220	PHCSA -P06 -022	-135	29~69	40	2	3	-	2	6	3	101	
3704 00060220	PHCSA -P06 -022	-150	29~84	55	2	3	-	2	6	3	101	
3704 00060230	PHCSA -P06 -023	-165	29~69	40	2	3	-	2	6	3	131	
3704 00060230	PHCSA -P06 -023	-180	29~84	55	2	3	-	2	6	3	131	
3704 00060210	PHCSA -P06 -021	-PHC07SA -90	29~85	56	2	3	-	2	6	3	40	
3704 00070220	PHCSA -P07 -022	-135	29~69	40	2	3	-	2	7	3	101	
3704 00070220	PHCSA -P07 -022	-150	29~84	55	2	3	-	2	7	3	101	
3704 00070230	PHCSA -P07 -023	-165	29~69	40	2	3	-	2	7	3	131	
3704 00070230	PHCSA -P07 -023	-180	29~84	55	2	3	-	2	7	3	131	
3704 00060210	PHCSA -P06 -021	-PHC08SA -90	29~85	56	2	3	-	2	6	3	40	
3704 00080220	PHCSA -P08 -022	-135	29~69	40	2	3	-	2	8	3	101	
3704 00080220	PHCSA -P08 -022	-150	29~84	55	2	3	-	2	8	3	101	
3704 00080230	PHCSA -P08 -023	-165	29~69	40	2	3	-	2	8	3	131	
3704 00080230	PHCSA -P08 -023	-180	29~84	55	2	3	-	2	8	3	131	
3704 00090310	PHCSA -P09 -031	-PHC09SA -90	40~85	45	2	3	3	2	9	3	40	
3704 00090320	PHCSA -P09 -032	-135	40~80	40	2	3	3	2	9	3	90	
3704 00090320	PHCSA -P09 -032	-150	40~95	55	2	3	3	2	9	3	90	
3704 00090330	PHCSA -P09 -033	-165	40~80	40	2	3	3	2	9	3	120	
3704 00090330	PHCSA -P09 -033	-180	40~95	55	2	3	3	2	9	3	120	
3704 00090310	PHCSA -P09 -031	-PHC10SA -90	40~85	45	2	3	3	2	9	3	40	
3704 00100320	PHCSA -P10 -032	-135	40~80	40	2	3	3	2	10	3	90	
3704 00100320	PHCSA -P10 -032	-150	40~95	55	2	3	3	2	10	3	90	
3704 00100330	PHCSA -P10 -033	-165	40~80	40	2	3	3	2	10	3	120	
3704 00100330	PHCSA -P10 -033	-180	40~95	55	2	3	3	2	10	3	120	
3704 00110410	PHCSA -P11 -041	-PHC11SA -90	40~85	45	2	3	3	2	11	3	40	
3704 00110420	PHCSA -P11 -042	-135	40~80	40	2	3	3	2	11	3	90	
3704 00110420	PHCSA -P11 -042	-150	40~95	55	2	3	3	2	11	3	90	
3704 00110430	PHCSA -P11 -043	-165	40~80	40	2	3	3	2	11	3	120	
3704 00110430	PHCSA -P11 -043	-180	40~95	55	2	3	3	2	11	3	120	
3704 00110410	PHCSA -P11 -041	-PHC12SA -90	40~85	45	2	3	3	2	11	3	40	
3704 00120420	PHCSA -P12 -042	-135	40~80	40	2	3	3	2	12	3	90	
3704 00120420	PHCSA -P12 -042	-150	40~95	55	2	3	3	2	12	3	90	
3704 00120430	PHCSA -P12 -043	-165	40~80	40	2	3	3	2	12	3	120	
3704 00120430	PHCSA -P12 -043	-180	40~95	55	2	3	3	2	12	3	120	
3704 00160310	PHCSA -P16 -031	-PHC16SA -135	40~83	43	1	3	3	2	16	3	65	
3704 00160320	PHCSA -P16 -032	-165	40~105	65	1	3	3	2	16	3	95	
3704 00160330	PHCSA -P16 -033	-180	40~105	65	1	3	3	2	16	3	110	
3704 00200210	PHCSA -P20 -021	-PHC20SA -135	40~78	38	1	3	3	2	20	3	60	
3704 00200220	PHCSA -P20 -022	-165	40~108	68	1	3	3	2	20	3	90	
3704 00200230	PHCSA -P20 -023	-180	40~110	70	1	3	3	2	20	3	105	
3704 00250210	PHCSA -P25 -021	-PHC25SA -135	50~78	28	1	3	3	2	25	3	50	
3704 00250220	PHCSA -P25 -022	-165	50~108	58	1	3	3	2	25	3	80	
3704 00250230	PHCSA -P25 -023	-180	50~120	70	1	3	3	2	25	3	95	
3704 00060210	PHCSA -P06 -021	BT50 -PHC06SA -105	29~121	92	2	3	-	2	6	3	40	
3704 00060220	PHCSA -P06 -022	-150	29~105	76	2	3	-	2	6	3	101	
3704 00060220	PHCSA -P06 -022	-165	29~120	91	2	3	-	2	6	3	101	
3704 00060230	PHCSA -P06 -023	-180	29~105	76	2	3	-	2	6	3	131	
3704 00060230	PHCSA -P06 -023	-195	29~120	91	2	3	-	2	6	3	131	
3704 00060210	PHCSA -P06 -021	-PHC07SA -105	29~121	92	2	3	-	2	6	3	40	
3704 00070220	PHCSA -P07 -022	-150	29~105	76	2	3	-	2	7	3	101	
3704 00070220	PHCSA -P07 -022	-165	29~120	91	2	3	-	2	7	3	101	
3704 00070230	PHCSA -P07 -023	-180	29~105	76	2	3	-	2	7	3	131	
3704 00070230	PHCSA -P07 -023	-195	29~120	91	2	3	-	2	7	3	131	
3704 00060210	PHCSA -P06 -021	-PHC08SA -105	29~121	92	2	3	-	2	6	3	40	
3704 00080220	PHCSA -P08 -022	-150	29~105	76	2	3	-	2	8	3	101	
3704 00080220	PHCSA -P08 -022	-165	29~120	91	2	3	-	2	8	3	101	
3704 00080230	PHCSA -P08 -023	-180	29~105	76	2	3	-	2	8	3	131	
3704 00080230	PHCSA -P08 -023	-195	29~120	91	2	3	-	2	8	3	131	
3704 00090320	PHCSA -P09 -032	-PHC09SA -150	40~116	76	2	3	3	2	9	3	90	
3704 00090320	PHCSA -P09 -032	-165	40~101	61	2	3	3	2	9	3	90	
3704 00090330	PHCSA -P09 -033	-180	40~116	76	2	3	3	2	9	3	120	
3704 00090330	PHCSA -P09 -033	-195	40~131	91	2	3	3	2	9	3	120	
3704 00100320	PHCSA -P10 -032	-PHC10SA -150	40~116	76	2	3	3	2	10	3	90	
3704 00100320	PHCSA -P10 -032	-165	40~101	61	2	3	3	2	10	3	90	
3704 00100330	PHCSA -P10 -033	-180	40~116	76	2	3	3	2	10	3	120	
3704 00100330	PHCSA -P10 -033	-195	40~131	91	2	3	3	2	10	3	120	
3704 00110420	PHCSA -P11 -042	-PHC11SA -150	40~116	76	2	3	3	2	11	3	90	
3704 00110420	PHCSA -P11 -042	-165	40~101	61	2	3	3	2	11	3	90	
3704 00110430	PHCSA -P11 -043	-180	40~116	76	2	3	3	2	11	3	120	
3704 00110430	PHCSA -P11 -043	-195	40~131	91	2	3	3	2	11	3	120	
3704 00120420	PHCSA -P12 -042	-PHC12SA -150	40~116	76	2	3	3	2	12	3	90	
3704 00120420	PHCSA -P12 -042	-165	40~101	61	2	3	3	2	12	3	90	
3704 00120430	PHCSA -P12 -043	-180	40~116	76	2	3	3	2	12	3	120	
3704 00120430	PHCSA -P12 -043	-195	40~131	91	2	3	3	2	12	3	120	
3704 00160310	PHCSA -P16 -031	-PHC16SA -150	40~83	43	1	3	3	2	16	3	65	
3704 00160320	PHCSA -P16 -032	-180	40~113	73	1	3	3	2	16	3	95	
3704 00160330	PHCSA -P16 -033	-195	40~128	88	1	3	3	2	16	3	110	
3704 00200210	PHCSA -P20 -021	-PHC20SA -150	40~78	38	1	3	3	2	20	3	60	
3704 00200220	PHCSA -P20 -022	-180	40~108	68	1	3	3	2	20	3	90	
3704 00200230	PHCSA -P20 -023	-195	40~123	83	1	3	3	2	20	3	105	
3704 00250210	PHCSA -P25 -021	-PHC25SA -150	50~78	28	1	3	3	2	25	3	50	
3704 00250220	PHCSA -P25 -022	-180	50~108	58	1	3	3	2	25	3	80	
3704 00250230	PHCSA -P25 -023	-195	50~123	73	1	3	3	2	25	3	95	

- BT
- CAT
- AHO
- HSK-A/E/F/C
- HSK-T
- C
- UTS
- Máquinas Especializadas
Specialized Machine
- Equipo Relacionado
Related Equipment
- Taladro de Biselado & Casquillo
Bush & Chamfering Drill
- Milling Chuck
- Collet Holder
- "R" Zero Holder
- Hydraulic Chuck
- Shrink Fit
- Tapping Chuck
- Arbors
- Function Holder
- Turning Tool
- Retention Stud
- Tool Shank Dimensions



PHC-H

Hydro Chuck Ω

- El Hydro Chuck Ω de alta rigidez es la mejor opción para maquinados pesados (de alto impacto).
- High Rigidity Hydro Chuck is the best holder for high efficiency rough machining.

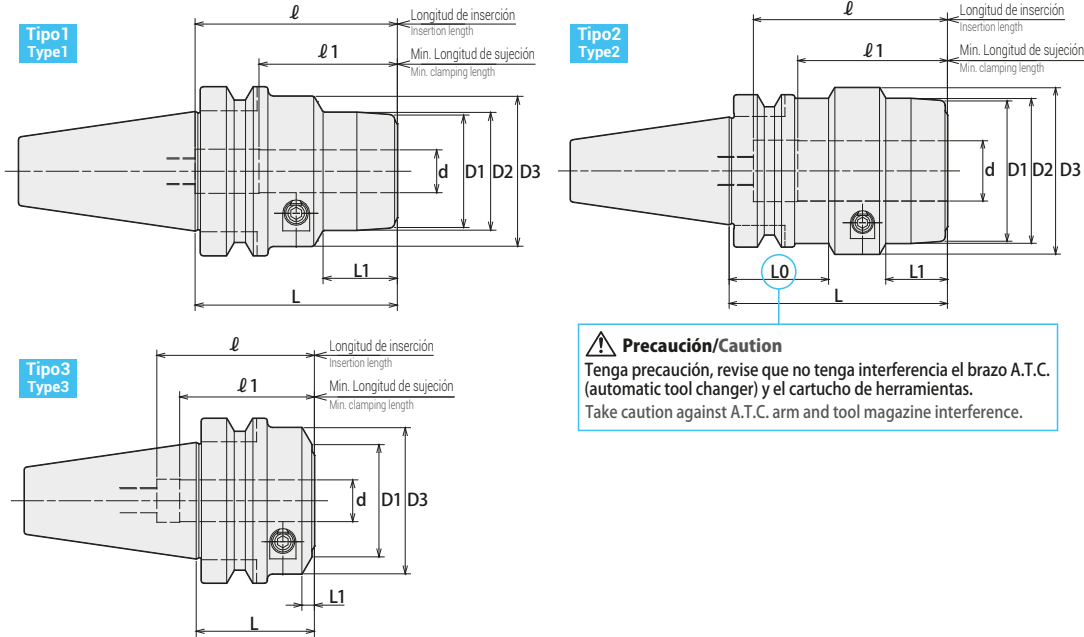

⚠ Precaución/ Caution
Tenga precaución, revise que no tenga interferencia el brazo A.T.C. (automatic tool changer) y el cartucho de herramientas.
Take caution against A.T.C. arm and tool magazine interference.

Código Code	Modelo Model	Tipo Type	d	L	L1	D1	D2	D3	L0	ℓ	ℓ1	Max. min ⁻¹	kg	Llave Allen (Opcional) Hex. Wrench (Optional)	
2580 00316045	BT40 -PHC16H	- 45	3	16	45	18	42	—	56	—	60	45	20,000	1.2	L-4T
2580 00316075	- 75	1	16	75	27	42	44	56	—	85	45	20,000	1.5		
2580 00320075	-PHC20H	- 75	1	20	75	32	48	50	60	—	80	50	20,000	1.6	
2580 00320105	- 105	1	20	105	32	48	50	60	—	95	50	20,000	2.1	L-5T	
2580 00325075	-PHC25H	- 75	2	25	75	25	58	60	69	31	80	55	16,000		1.8
2580 00325105	- 105	2	25	105	35	58	60	69	39	110	55	16,000	2.4		
2580 00332105	-PHC32H	- 105	2	32	105	40	63	65	75	39	90	65	12,000	2.4	L-5T
2580 00332135	- 135	2	32	135	47	63	65	75	39	120	65	12,000	3.2		
2580 00516075	BT50 -PHC16H	- 75	1	16	75	17	44	56	—	75	45	15,000	4.0	L-4T	
2580 00516105	- 105	1	16	105	27	42	44	56	—	105	45	15,000	4.4		
2580 00520075	-PHC20H	- 75	1	20	75	17	—	50	60	—	80	50	15,000		4.1
2580 00520105	- 105	1	20	105	32	48	50	60	—	110	50	15,000	4.5	L-5T	
2580 00525075	-PHC25H	- 75	1	25	75	17	—	60	69	—	80	55	15,000		4.2
2580 00525105	- 105	1	25	105	35	58	60	69	—	110	55	15,000	4.8		
2580 00525135	- 135	1	25	135	35	58	60	69	—	110	55	15,000	5.5	L-5T	
2580 00532075	-PHC32H	- 75	1	32	75	17	—	65	75	—	90	65	12,000		4.1
2580 00532105	- 105	1	32	105	47	63	65	75	—	120	65	12,000	4.6		
2580 00532135	- 135	1	32	135	47	63	65	75	—	120	65	12,000	5.6	L-6T	
2580 00542075	-PHC42H	- 75	1	42	75	37	—	74	90	—	100	73	10,000		4.1
2580 00542105	- 105	1	42	105	46	78	80	90	—	130	73	10,000	5.0		
2580 00542135	- 135	1	42	135	52	78	80	90	—	130	73	10,000	6.2		

- La tolerancia de diámetro del zanco de la herramienta deben estar dentro de h7. Es recomendada una tolerancia h6 o 0/-0.01 cuando se están creando nuevas herramientas de corte.
- PHC20H y PHC32H cuentan con orificios con clavija de torque, para las boquillas que tienen incluida la clavija de torque opresor.
- El tornillo Allen (incluido) es necesario para tapar el orificio de aire para habilitar la alimentación de refrigeración por centro de herramienta.
- La velocidad permitida se ve altamente afectada por la rigidez del husillo de la máquina y el balance de la herramienta de corte. Incrementar gradualmente de una velocidad lenta, hasta llegar a la velocidad adecuada.

Boquilla PHS•H

PHS•H Collet

Pág. 123

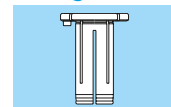

Tornillo de retención

Stopper Bolt

Pág. 123



- Tool shank diameter tolerance must be within h7. h6 or 0/-0.01 tolerance is recommended when newly making a cutting tool.
- PHC20H and PHC32H have pin holes for collet with stopper pin on its body.
- Hex-head screws (included) are necessary to plug air hole for center through coolant feed.
- Allowed speed is greatly affected by the stiffness of the machine spindle and the balance of the cutting tool. Gradually increase from a low speed, and use at the proper speed.

Ejemplo para Ordenar - Ordering Example

BT40 - PHC 16 H - 45

Interfaz y diámetro de husillo

Shank size

Diámetro Interior

I.D. (d)

Longitud de Proyección

Projection length (L)

Tornillo de retención (para CAT, BT, AHO, UTS)

Stopper Bolt (for CAT, BT, AHO, UTS)

BL

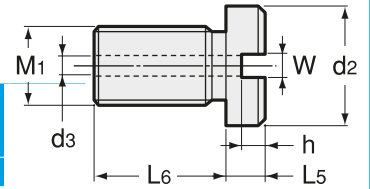

Código Code	Modelo Model	M1 P=1.0	L ₅	L ₆	W	h	d ₂	d ₃	Diámetro Interno del portaherramienta disponible Available Chuck I.D.		
									CAT, BT	AHO	UTS
0711 040016 ※※	BL 16 - L ₅	10	5, 15, 25	14	5	3,5	15	4,5	—	—	16 ~ 42
0711 040020 ※※	BL 20 - L ₅	12	5, 15, 25	14	5	3,5	18	4,5	16, 20, 25	—	—
0711 040032 ※※	BL 32 - L ₅	18	10, 20, 35	17	5	5	25	4,5	32, 42	—	—

Ejemplo para Ordenar
Ordering Example

BL16 - 15
Medida - Size L5

Tornillo de retención (para HSK)

Stopper Bolt (for HSK)

HSK-BL

Código Code	Modelo Model	M ₁	L ₅	L ₆	W	h	d ₂	d ₃	Interfaz y diámetro de husillo disponible Available Shank Size
									5691 04006305
5691 040063 ※※	HSK63 -BL - L ₅	M8 P=1.25	15, 25	7,5	5	3	15	4	HSK63A
5691 040100 ※※	HSK100 -BL - L ₅	M10 P=1.5	5, 15, 25	14	5	3,5	15	4,5	HSK100A

Ejemplo para Ordenar
Ordering Example

HSK63 - BL - 15
Interfaz y diámetro de husillo
Shank Size L5

1. Seleccione correctamente la dimensión L5 revisando la longitud mínima de inserción y la profundidad de diámetro interno del zanco.
 2. Los tornillos de retención no pueden ser utilizados con HSK63A-PHC32H-105 ó HSK100A-PHC32H-110.
1. Choose right L5 dimension by checking minimum insertion length and shank I.D. depth.
 2. Stopper bolts cannot be used with HSK63A-PHC32H-105 or HSK100A-PHC32H-110.

Boquilla con clavija de tope

Collet with stopper pin

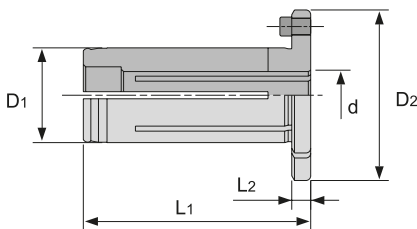

Longitud mínima de sujeción

Min. Clamping length

Diámetro Interno de la boquilla Collet I.D. [d]	Min. Longitud de sujeción Min. Clamping length
6, 8	29
10, 12, 16, 20	40
25	50

Para cortador con vena de lubricación

For cutter with oil hole



Código Code	Modelo Model	D ₁	D ₂	L ₁	L ₂	[d]
2584 300520 ※※	PHS 20H - [d] -OH	20	41	60	4	6, 8, 10, 12, 16
2584 300532 ※※	PHS 32H - [d] -OH	32	55	72	4	6, 8, 10, 12, 16, 20, 25

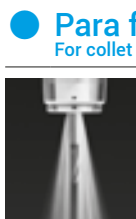

Para función de refrigerante por costados de la boquilla

For collet through coolant

Código Code	Modelo Model	D ₁	D ₂	L ₁	L ₂	[d]
2584 300620 ※※	PHS 20H - [d] -C	20	41	60	4	6, 8, 10, 12, 16
2584 300632 ※※	PHS 32H - [d] -C	32	55	72	4	6, 8, 10, 12, 16, 20, 25

Reemplazar ※※ con el diámetro interno (d) a utilizar.

La boquilla con clavija de tope puede ser utilizada únicamente con PHC20H y PHC32H.

※※ Would be used I.D. (d).

The collet with stopper pin can be used with PHC20H and PHC32H only.

Ejemplo para Ordenar - Ordering Example

Para sujetar una herramienta de corte de φ6 con BT40-PHC20H-75
To hold φ6 cutting tool with BT40-PHC20H-75

Portaherramienta / Chuck

Boquilla / Collet

BT40-PHC20H-75



PHS20H-06-OH

Para sujetar una herramienta de corte de φ6 utilizando una boquilla con alimentación de refrigerante por costados con BT40-PHC20H-75
To hold φ6 cutting tool using collet through coolant feed with BT40-PHC20H-75

Portaherramienta / Chuck

Boquilla / Collet

BT40-PHC20H-75



PHS20H-06-C

Shrink Fit (DIN Standard)

- El método de contracción sujeta firmemente a una herramienta de corte al calentar y enfriar el portaherramienta. Alta precisión y mucha fuerza de sujeción. (Para DIN)
- Shrinkage method clamps a cutting tool firmly by heating and cooling the chuck. High precision, rigidity and strong Clamping force. (DIN Type)

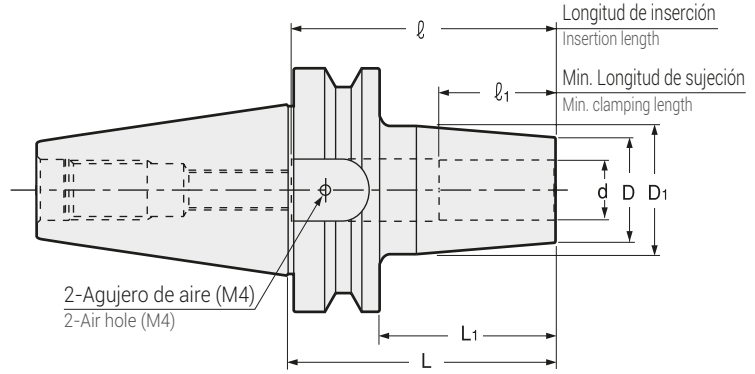

Medidas en Pulgadas - Inch Sizes

Unidad : Pulgadas
Unit : Inch

	Código Code	Modelo Model	d	L	L1	D	D1	l1	l	kg
Milling Chuck	3060 43108080	BT30 -SRD0250 A -80	0.250	3.150	2.283	0.827	1.063	1.417	1.024	
	3060 43108105	-105	0.250	4.134	3.268	0.827	1.063	1.417	1.024	
	3060 43108120	-120	0.250	4.724	3.858	0.827	1.063	1.417	1.024	
Collet Holder	3060 43110080	BT30 -SRD0312 A -80	0.312	3.150	2.283	0.827	1.063	1.969	1.024	0.6
	3060 43110105	-105	0.312	4.134	3.268	0.827	1.063	1.969	1.024	
	3060 43110120	-120	0.312	4.724	3.858	0.827	1.063	1.969	1.024	
"R" Zero Holder	3060 43112080	BT30 -SRD0375 A -80	0.375	3.150	2.283	0.945	1.260	1.969	1.260	
	3060 43112105	-105	0.375	4.134	3.268	0.945	1.260	1.969	1.260	
	3060 43112120	-120	0.375	4.724	3.858	0.945	1.260	1.969	1.260	
Hydraulic Chuck	3060 43116080	BT30 -SRD0500 A -80	0.500	3.150	2.283	0.945	1.260	2.244	1.457	0.6
	3060 43116105	-105	0.500	4.134	3.268	0.945	1.260	2.244	1.457	
	3060 43116120	-120	0.500	4.724	3.858	0.945	1.260	2.244	1.457	
Shrink Fit	3060 43120080	BT30 -SRD0625 A -80	0.625	3.150	2.283	1.063	1.339	3.150	1.575	0.6
	3060 43120105	-105	0.625	4.134	3.268	1.063	1.339	3.150	1.575	
	3060 43120120	-120	0.625	4.724	3.858	1.063	1.339	3.150	1.575	
Tapping Chuck	3060 43308090	BT40 SRD0250 A -90	0.250	3.543	2.480	0.827	1.063	1.417	1.024	1.2
	3060 43308120	-120	0.250	4.724	3.661	0.827	1.063	1.417	1.024	
	3060 43308160	-160	0.250	6.299	5.236	0.827	1.063	1.417	1.024	
Anchors	3060 43310090	BT40 -SRD0312 A -90	0.312	3.543	2.480	0.827	1.063	1.969	1.024	
	3060 43310120	-120	0.312	4.724	3.661	0.827	1.063	1.969	1.024	
	3060 43310160	-160	0.312	6.299	5.236	0.827	1.063	1.969	1.024	
Function Holder	3060 43312090	BT40 -SRD0375 A -90	0.375	3.543	2.480	0.945	1.260	1.969	1.260	1.3
	3060 43312120	-120	0.375	4.724	3.661	0.945	1.260	1.969	1.260	
	3060 43312160	-160	0.375	6.299	5.236	0.945	1.260	1.969	1.260	
Turning Tool	3060 43316090	BT40 -SRD0500 A -90	0.500	3.543	2.480	0.945	1.260	2.244	1.457	1.2
	3060 43316120	-120	0.500	4.724	3.661	0.945	1.260	2.244	1.457	
	3060 43316160	-160	0.500	6.299	5.236	0.945	1.260	2.244	1.457	
Retention Stud	3060 43320090	BT40 -SRD0625 A -90	0.625	3.543	2.480	1.063	1.339	3.150	1.575	
	3060 43320120	-120	0.625	4.724	3.661	1.063	1.339	3.150	1.575	
	3060 43320160	-160	0.625	6.299	5.236	1.063	1.339	3.150	1.575	
Tool Shank Dimensions	3060 43324090	BT40 -SRD0750 A -90	0.750	3.543	2.480	1.299	1.654	3.386	1.575	
	3060 43324120	-120	0.750	4.724	3.661	1.299	1.654	3.937	1.575	
	3060 43324160	-160	0.750	6.299	5.236	1.299	1.654	3.937	1.575	
Retention Stud	3060 43328090	BT40 -SRD0875 A -90	0.875	3.543	2.480	1.299	1.654	3.386	1.654	
	3060 43328120	-120	0.875	4.724	3.661	1.299	1.654	3.937	1.654	
	3060 43328160	-160	0.875	6.299	5.236	1.299	1.654	3.937	1.654	
Tool Shank Dimensions	3060 43332100	BT40 -SRD1000 A -100	1.000	3.937	2.874	1.732	2.087	3.780	1.890	
	3060 43332120	-120	1.000	4.724	3.661	1.732	2.087	3.937	1.890	
	3060 43332160	-160	1.000	6.299	5.236	1.732	2.087	3.937	1.890	

Medidas en Pulgadas - Inch Sizes

Unidad : Pulgadas
Unit : Inch

Código Code	Modelo Model	d	L	L1	D	D1	ℓ1	ℓ	kg
3060 43340100	BT40 -SRD1250 A -100	1.250	3.937	2.874	1.732	2.087	3.780	1.890	
3060 43340120	-120	1.250	4.724	3.661	1.732	2.087	3.937	1.890	
3060 43340160	-160	1.250	6.299	5.236	1.732	2.087	3.937	1.890	
3060 43508100	BT50 -SRD0250 A -100	0.250	3.937	2.441	0.827	1.063	1.417	1.024	
3060 43508120	-120	0.250	4.724	3.228	0.827	1.063	1.417	1.024	
3060 43508160	-160	0.250	6.299	4.803	0.827	1.063	1.417	1.024	
3060 43510100	BT50 -SRD0312 A -100	0.312	3.937	2.441	0.827	1.063	1.969	1.024	
3060 43510120	-120	0.312	4.724	3.228	0.827	1.063	1.969	1.024	
3060 43510160	-160	0.312	6.299	4.803	0.827	1.063	1.969	1.024	
3060 43512100	BT50 -SRD0375 A -100	0.375	3.937	2.441	0.945	1.260	1.969	1.260	
3060 43512120	-120	0.375	4.724	3.228	0.945	1.260	1.969	1.260	
3060 43512160	-160	0.375	6.299	4.803	0.945	1.260	1.969	1.260	
3060 43516100	BT50 -SRD0500 A -100	0.500	3.937	2.441	0.945	1.260	2.244	1.457	
3060 43516120	-120	0.500	4.724	3.228	0.945	1.260	2.244	1.457	3.9
3060 43516160	-160	0.500	6.299	4.803	0.945	1.260	2.244	1.457	
3060 43520100	BT50 -SRD0625 A -100	0.625	3.937	2.441	1.063	1.339	3.150	1.575	
3060 43520120	-120	0.625	4.724	3.228	1.063	1.339	3.150	1.575	
3060 43520160	-160	0.625	6.299	4.803	1.063	1.339	3.150	1.575	
3060 43524100	BT50 -SRD0750 A -100	0.750	3.937	2.441	1.299	1.654	3.386	1.575	
3060 43524120	-120	0.750	4.724	3.228	1.299	1.654	3.937	1.575	
3060 43524160	-160	0.750	6.299	4.803	1.299	1.654	3.937	1.575	
3060 43528100	BT50 -SRD0875 A -100	0.875	3.937	2.441	1.299	1.654	3.386	1.654	
3060 43528120	-120	0.875	4.724	3.228	1.299	1.654	3.937	1.654	
3060 43528160	-160	0.875	6.299	4.803	1.299	1.654	3.937	1.654	
3060 43532110	BT50 -SRD1000 A -110	1.000	4.331	2.835	1.732	2.087	3.780	1.890	
3060 43532135	-135	1.000	5.315	3.819	1.732	2.087	3.937	1.890	
3060 43532160	-160	1.000	6.299	4.803	1.732	2.087	3.937	1.890	
3060 43540110	BT50 -SRD1250 A -110	1.250	4.331	2.835	1.732	2.087	3.937	1.890	
3060 43540135	-135	1.250	5.315	3.819	1.732	2.087	3.937	1.890	
3060 43540160	-160	1.250	6.299	4.803	1.732	2.087	3.937	1.890	
3060 43548110	BT50 -SRD1500 A -110	1.500	4.331	2.835	1.732	2.087	3.937	1.890	3.6
3060 43548135	-135	1.500	5.315	3.819	1.732	2.087	3.937	1.890	
3060 43548160	-160	1.500	6.299	4.803	1.732	2.087	3.937	1.890	

1. Siempre use herramientas de zanco de carburo con tolerancia dentro de h6.
2. Use dos piezas de tornillos Allen opresor (incluidos) M4 x 5 (S) para cerrar los orificios vacíos en el portaherramienta cuando se use refrigerante interno.

1. Always use carbide shank tools with h6 tolerance.
2. Use 2pcs. of M4 x 5 (S) hex. screw (included) to close air holes on the chuck when internal coolant is used.

Tabla de dispositivos térmicos Heating device chart		
Dispositivo térmico Heating device	Portaherramienta - chuck	
	SRD0250A, SRD0312A	SRD0375A~SRD1500A
ISG3400	Sí - Yes	Sí - Yes
SRK-HA1, HB2	No	Sí - Yes

Ejemplo para Ordenar - Ordering Example

BT40 - SRD 0250 A - 120

Interfaz y diámetro de husillo Shank size	Diámetro Interno I.D. (d)	Longitud de proyección Projection length (L)
--	------------------------------	---

Shrink Fit (DIN Standard)

- El método de contracción sujeta firmemente a una herramienta de corte al calentar y enfriar el portaherramienta. Alta precisión y mucha fuerza de sujeción. (Para DIN)
- Shrinkage method clamps a cutting tool firmly by heating and cooling the chuck. High precision, rigidity and strong Clamping force. (DIN Type)

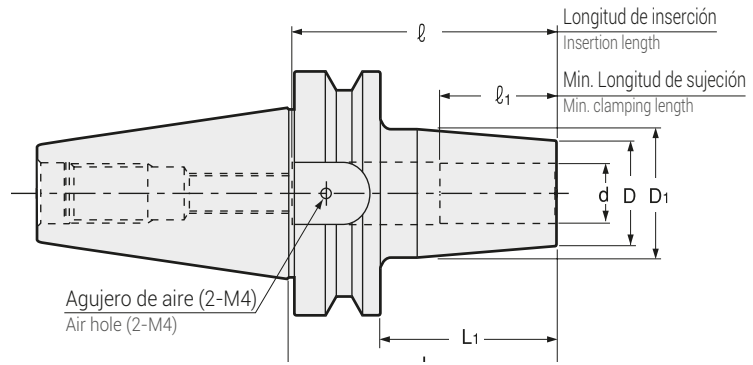

Medidas Métricas - Metric Sizes

Unidad : Métrico
Unit : Metric

	Código Code	Modelo Model	d	L	L ₁	D	D ₁	ℓ ₁	ℓ	kg
Milling Chuck	3060 41106080	BT30 -SRD6A -80	6	80	58	21	27	26	26 ~ 36	0.6
	3060 41106105	-105	6	105	83	21	27	26	26 ~ 36	
	3060 41106120	-120	6	120	98	21	27	26	26 ~ 36	
Collet Holder	3060 41108080	BT30 -SRD8A -80	8	80	58	21	27	26	26 ~ 50	0.6
	3060 41108105	-105	8	105	83	21	27	26	26 ~ 50	
	3060 41108120	-120	8	120	98	21	27	26	26 ~ 50	
"R" Zero Holder	3060 41110080	BT30 -SRD10A -80	10	80	58	24	32	32	32 ~ 50	0.7
	3060 41110105	-105	10	105	83	24	32	32	32 ~ 50	
	3060 41110120	-120	10	120	98	24	32	32	32 ~ 50	
Hydraulic Chuck	3060 41112080	BT30 -SRD12A -80	12	80	58	24	32	37	37 ~ 70	
	3060 41112105	-105	12	105	83	24	32	37	37 ~ 70	
	3060 41112120	-120	12	120	98	24	32	37	37 ~ 70	
Shrink Fit	3060 41114080	BT30 -SRD14A -80	14	80	58	27	34	37	37 ~ 70	
	3060 41114105	-105	14	105	83	27	34	37	37 ~ 70	
	3060 41114120	-120	14	120	98	27	34	37	37 ~ 70	
Tapping Chuck	3060 41116080	BT30 -SRD16A -80	16	80	58	27	34	40	40 ~ 80	0.6
	3060 41116105	-105	16	105	83	27	34	40	40 ~ 80	
	3060 41116120	-120	16	120	98	27	34	40	40 ~ 80	
Abitors	3060 41306090	BT40 -SRD6A -90	6	90	63	21	27	26	26 ~ 36	1.2
	3060 41306120	-120	6	120	93	21	27	26	26 ~ 36	
	3060 41306160	-160	6	160	133	21	27	26	26 ~ 36	
Function Holder	3060 41308090	BT40 -SRD8A -90	8	90	63	21	27	26	26 ~ 50	1.2
	3060 41308120	-120	8	120	93	21	27	26	26 ~ 50	
	3060 41308160	-160	8	160	133	21	27	26	26 ~ 50	
Turning Tool	3060 41310090	BT40 -SRD10A -90	10	90	63	24	32	32	32 ~ 50	1.3
	3060 41310120	-120	10	120	93	24	32	32	32 ~ 50	
	3060 41310160	-160	10	160	133	24	32	32	32 ~ 50	
Retention Stud	3060 41312090	BT40 -SRD12A -90	12	90	63	24	32	37	37 ~ 70	
	3060 41312120	-120	12	120	93	24	32	37	37 ~ 70	
	3060 41312160	-160	12	160	133	24	32	37	37 ~ 70	
Tool Shank Dimensions	3060 41314090	BT40 -SRD14A -90	14	90	63	27	34	37	37 ~ 70	
	3060 41314120	-120	14	120	93	27	34	37	37 ~ 70	
	3060 41314160	-160	14	160	133	27	34	37	37 ~ 70	
Retention Stud	3060 41316090	BT40 -SRD16A -90	16	90	63	27	34	40	40 ~ 80	
	3060 41316120	-120	16	120	93	27	34	40	40 ~ 80	
	3060 41316160	-160	16	160	133	27	34	40	40 ~ 80	
Tool Shank Dimensions	3060 41318090	BT40 -SRD18A -90	18	90	63	33	42	40	40 ~ 80	1.4
	3060 41318120	-120	18	120	93	33	42	40	40 ~ 80	
	3060 41318160	-160	18	160	133	33	42	40	40 ~ 80	

Medidas Métricas - Metric Sizes

Unidad : Métrico
Unit : Metric

Código Code	Modelo Model	d	L	L1	D	D1	ℓ1	ℓ	kg
3060 41320090	BT40 -SRD20A -90	20	90	63	33	42	42	42 ~ 86	1.3
3060 41320120	-120	20	120	93	33	42	42	42 ~ 100	
3060 41320160	-160	20	160	133	33	42	42	42 ~ 100	
3060 41325100	BT40 -SRD25A -100	25	100	73	44	53	48	48 ~ 96	
3060 41325120	-120	25	120	93	44	53	48	48 ~ 100	2.0
3060 41325160	-160	25	160	133	44	53	48	48 ~ 100	
3060 41332100	BT40 -SRD32A -100	32	100	73	44	53	52	52 ~ 96	1.5
3060 41332120	-120	32	120	93	44	53	52	52 ~ 100	1.8
3060 41332160	-160	32	160	133	44	53	52	52 ~ 100	
3060 41506100	BT50 -SRD6A -100	6	100	62	21	27	26	26 ~ 36	
3060 41506120	-120	6	120	82	21	27	26	26 ~ 36	
3060 41506160	-160	6	160	122	21	27	26	26 ~ 36	
3060 41508100	BT50 -SRD8A -100	8	100	62	21	27	26	26 ~ 50	
3060 41508120	-120	8	120	82	21	27	26	26 ~ 50	
3060 41508160	-160	8	160	122	21	27	26	26 ~ 50	
3060 41510100	BT50 -SRD10A -100	10	100	62	24	32	32	32 ~ 50	3.8
3060 41510120	-120	10	120	82	24	32	32	32 ~ 50	
3060 41510160	-160	10	160	122	24	32	32	32 ~ 50	
3060 41512100	BT50 -SRD12A -100	12	100	62	24	32	37	37 ~ 70	3.8
3060 41512120	-120	12	120	82	24	32	37	37 ~ 70	
3060 41512160	-160	12	160	122	24	32	37	37 ~ 70	
3060 41514100	BT50 -SRD14A -100	14	100	62	27	34	37	37 ~ 70	
3060 41514120	-120	14	120	82	27	34	37	37 ~ 70	
3060 41514160	-160	14	160	122	27	34	37	37 ~ 70	
3060 41516100	BT50 -SRD16A -100	16	100	62	27	34	40	40 ~ 80	3.8
3060 41516120	-120	16	120	82	27	34	40	40 ~ 80	
3060 41516160	-160	16	160	122	27	34	40	40 ~ 80	
3060 41518100	BT50 -SRD18A -100	18	100	62	33	42	40	40 ~ 80	4.0
3060 41518120	-120	18	120	82	33	42	40	40 ~ 80	
3060 41518160	-160	18	160	122	33	42	40	40 ~ 80	
3060 41520100	BT50 -SRD20A -100	20	100	62	33	42	42	42 ~ 100	3.9
3060 41520120	-120	20	120	82	33	42	42	42 ~ 100	
3060 41520160	-160	20	160	122	33	42	42	42 ~ 100	
3060 41525110	BT50 -SRD25A -110	25	110	72	44	53	48	48 ~ 110	4.3
3060 41525135	-135	25	135	97	44	53	48	48 ~ 110	
3060 41525160	-160	25	160	122	44	53	48	48 ~ 110	
3060 41532110	BT50 -SRD32A -110	32	110	72	44	53	52	52 ~ 120	4.0
3060 41532135	-135	32	135	97	44	53	52	52 ~ 120	
3060 41532160	-160	32	160	122	44	53	52	52 ~ 120	

1. Siempre use herramientas con zanco de carburo y con tolerancia dentro de h6.
 2. Use dos piezas de tornillos Allen opresor (incluidos) M4 x 5 (S) para cerrar los orificios vacíos en el portaherramienta cuando se use refrigerante interno.
1. Always use carbide shank tools with h6 tolerance.
 2. Use 2pcs. of M4 x 5 (S) hex. screw (included) to close air holes on the chuck when internal coolant is used.

Tabla de dispositivos térmicos Heating device chart		
Dispositivo térmico Heating device	Portaherramienta - chuck	
	SRD0250A, SRD0312A	SRD0375A~SRD1500A
ISG3400	Sí - Yes	Sí - Yes
SRK-HA1, HB2	No	Sí - Yes

Ejemplo para Ordenar - Ordering Example

BT40 - SRD 10 A - 120

Interfaz y diámetro de husillo

Diámetro Interno

Longitud de proyección

Shank size

I.D. (d)

Projection length (L)

Shrink Fit (Slim Type)

- El método de contracción sujeta firmemente a una herramienta de corte al calentar y enfriar el portaherramienta. Alta precisión y mucha fuerza de sujeción. (Tipo delgado)
- Shrinkage method clamps a cutting tool firmly by heating and cooling the chuck. High precision and strong Clamping force. (Slim Type)

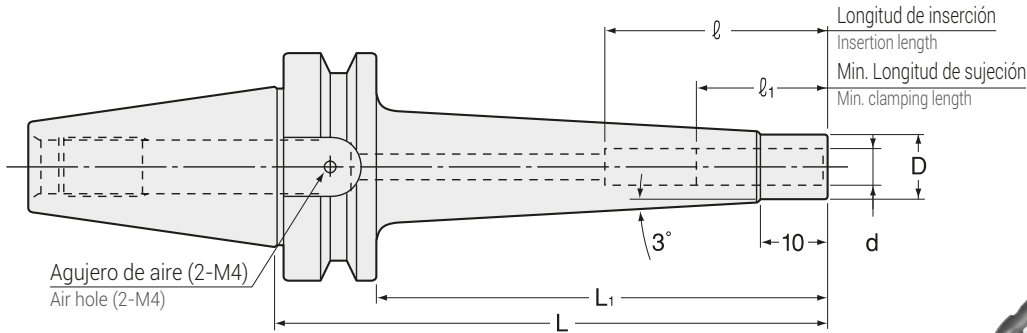

Medidas en Pulgadas - Inch Sizes

Unidad : Pulgadas
Unit : Inch

Código Code	Modelo Model	d	L	L1	D	I	I1
3060 33108105	BT30 -SRS0250A -105	0.250	4.134	3.268	0.374	1.024	1.417
3060 33108135	-135	0.250	5.315	4.449	0.374	1.024	1.417
3060 33110105	BT30 -SRS0312A -105	0.312	4.134	3.268	0.433	1.024	1.969
3060 33110135	-135	0.312	5.315	4.449	0.433	1.024	1.969
3060 33112105	BT30 -SRS0375A -105	0.375	4.134	3.268	0.512	1.260	1.969
3060 33112135	-135	0.375	5.315	4.449	0.512	1.260	1.969
3060 33116105	BT30 -SRS0500A -105	0.500	4.134	3.268	0.591	1.457	2.756
3060 33116135	-135	0.500	5.315	4.449	0.591	1.457	2.756
3060 33120105	BT30 -SRS0625A -105	0.625	4.134	3.268	0.787	1.575	3.150
3060 33120135	-135	0.625	5.315	4.449	0.787	1.575	3.150
3060 33308105	BT40 -SRS0250A -105	0.250	4.134	3.071	0.374	1.024	1.417
3060 33308135	-135	0.250	5.315	4.252	0.374	1.024	1.417
3060 33310105	BT40 -SRS0312A -105	0.312	4.134	3.071	0.433	1.024	1.969
3060 33310135	-135	0.312	5.315	4.252	0.433	1.024	1.969
3060 33312105	BT40 -SRS0375A -105	0.375	4.134	3.071	0.512	1.260	1.969
3060 33312135	-135	0.375	5.315	4.252	0.512	1.260	1.969
3060 33312165	-165	0.375	6.496	5.433	0.512	1.260	1.969
3060 33316105	BT40 -SRS0500A -105	0.500	4.134	3.071	0.591	1.457	2.756
3060 33316135	-135	0.500	5.315	4.252	0.591	1.457	2.756
3060 33316165	-165	0.500	6.496	5.433	0.591	1.457	2.756
3060 33320105	BT40 -SRS0625A -105	0.625	4.134	3.071	0.787	1.575	3.150
3060 33320135	-135	0.625	5.315	4.252	0.787	1.575	3.150
3060 33320165	-165	0.625	6.496	5.433	0.787	1.575	3.150
3060 33324105	BT40 -SRS0750A -105	0.750	4.134	3.071	1.024	1.654	3.937
3060 33324135	-135	0.750	5.315	4.252	1.024	1.654	3.937
3060 33324165	-165	0.750	6.496	5.433	1.024	1.654	3.937
3060 33508105	BT50 -SRS0250A -105	0.250	4.134	2.638	0.374	1.024	1.417
3060 33508135	-135	0.250	5.315	3.819	0.374	1.024	1.417
3060 33510105	BT50 -SRS0312A -105	0.312	4.134	2.638	0.433	1.024	1.969
3060 33510135	-135	0.312	5.315	3.819	0.433	1.024	1.969
3060 33512105	BT50 -SRS0375A -105	0.375	4.134	2.638	0.512	1.260	1.969
3060 33512135	-135	0.375	5.315	3.819	0.512	1.260	1.969
3060 33512165	-165	0.375	6.496	5.000	0.512	1.260	1.969
3060 33512195	-195	0.375	7.677	6.181	0.512	1.260	1.969
3060 33516105	BT50 -SRS0500A -105	0.500	4.134	2.638	0.591	1.457	2.756
3060 33516135	-135	0.500	5.315	3.819	0.591	1.457	2.756
3060 33516165	-165	0.500	6.496	5.000	0.591	1.457	2.756
3060 33516195	-195	0.500	7.677	6.181	0.591	1.457	2.756
3060 33520105	BT50 -SRS0625A -105	0.625	4.134	2.638	0.787	1.575	3.150
3060 33520135	-135	0.625	5.315	3.819	0.787	1.575	3.150
3060 33520165	-165	0.625	6.496	5.000	0.787	1.575	3.150
3060 33520195	-195	0.625	7.677	6.181	0.787	1.575	3.150
3060 33524105	BT50 -SRS0750A -105	0.750	4.134	2.638	1.024	1.654	3.937
3060 33524135	-135	0.750	5.315	3.819	1.024	1.654	3.937
3060 33524165	-165	0.750	6.496	5.000	1.024	1.654	3.937
3060 33524195	-195	0.750	7.677	6.181	1.024	1.654	3.937

Medidas Métricas - Metric Sizes

Unidad : Métrico
Unit : Metric

Código Code	Modelo Model	d	L	L1	D	ℓ1	ℓ	kg
3060 31206105	BT30 -SRS6A -105	6	105	83	9	26	26 ~ 36	0.6
3060 31206135	-135	6	135	113	9	26	26 ~ 36	0.6
3060 31208105	BT30 -SRS8A -105	8	105	83	11	26	26 ~ 50	0.7
3060 31208135	-135	8	135	113	11	26	26 ~ 50	0.7
3060 31110105	BT30 -SRS10A -105	10	105	83	13	32	32 ~ 50	0.7
3060 31110135	-135	10	135	113	13	32	32 ~ 50	0.7
3060 31112105	BT30 -SRS12A -105	12	105	83	15	37	37 ~ 70	0.7
3060 31112135	-135	12	135	113	15	37	37 ~ 70	0.8
3060 31116105	BT30 -SRS16A -105	16	105	83	20	40	40 ~ 80	0.8
3060 31116135	-135	16	135	113	20	40	40 ~ 80	0.8
3060 31306105	BT40 -SRS6A -105	6	105	78	9	26	26 ~ 36	1.1
3060 31306135	-135	6	135	108	9	26	26 ~ 36	1.1
3060 31306165	-165	6	165	138	9	26	26 ~ 36	
3060 31308105	BT40 -SRS8A -105	8	105	78	11	26	26 ~ 50	1.2
3060 31308135	-135	8	135	108	11	26	26 ~ 50	1.2
3060 31308165	-165	8	165	138	11	26	26 ~ 50	
3060 31310105	BT40 -SRS10A -105	10	105	78	13	32	32 ~ 50	1.3
3060 31310135	-135	10	135	108	13	32	32 ~ 50	1.4
3060 31310165	-165	10	165	138	13	32	32 ~ 50	1.5
3060 31312105	BT40 -SRS12A -105	12	105	78	15	37	37 ~ 70	1.3
3060 31312135	-135	12	135	108	15	37	37 ~ 70	1.4
3060 31312165	-165	12	165	138	15	37	37 ~ 70	1.5
3060 31316105	BT40 -SRS16A -105	16	105	78	20	40	40 ~ 80	1.5
3060 31316135	-135	16	135	108	20	40	40 ~ 80	1.6
3060 31316165	-165	16	165	138	20	40	40 ~ 80	1.7
3060 31320105	BT40 -SRS20A -105	20	105	78	26	42	42 ~ 100	1.6
3060 31320135	-135	20	135	108	26	42	42 ~ 100	1.7
3060 31320165	-165	20	165	138	26	42	42 ~ 100	1.8
3060 31506105	BT50 -SRS6A -105	6	105	67	9	26	26 ~ 36	3.5
3060 31506135	-135	6	135	97	9	26	26 ~ 36	3.5
3060 31506165	-165	6	165	127	9	26	26 ~ 36	
3060 31508105	BT50 -SRS8A -105	8	105	67	11	26	26 ~ 50	3.6
3060 31508135	-135	8	135	97	11	26	26 ~ 50	3.6
3060 31508165	-165	8	165	127	11	26	26 ~ 50	
3060 31510105	BT50 -SRS10A -105	10	105	67	13	32	32 ~ 50	3.8
3060 31510135	-135	10	135	97	13	32	32 ~ 50	3.8
3060 31510165	-165	10	165	127	13	32	32 ~ 50	4.0
3060 31510195	-195	10	195	157	13	32	32 ~ 50	4.1
3060 31512105	BT50 -SRS12A -105	12	105	67	15	37	37 ~ 70	3.8
3060 31512135	-135	12	135	97	15	37	37 ~ 70	3.9
3060 31512165	-165	12	165	127	15	37	37 ~ 70	4.0
3060 31512195	-195	12	195	157	15	37	37 ~ 70	4.1
3060 31516105	BT50 -SRS16A -105	16	105	67	20	40	40 ~ 80	3.9
3060 31516135	-135	16	135	97	20	40	40 ~ 80	3.9
3060 31516165	-165	16	165	127	20	40	40 ~ 80	4.2
3060 31516195	-195	16	195	157	20	40	40 ~ 80	4.2
3060 31520105	BT50 -SRS20A -105	20	105	67	26	42	42 ~ 100	4.0
3060 31520135	-135	20	135	97	26	42	42 ~ 100	4.0
3060 31520165	-165	20	165	127	26	42	42 ~ 100	4.3
3060 31520195	-195	20	195	157	26	42	42 ~ 100	4.5

1. Siempre use herramientas con zanco de carburo y con tolerancia dentro de h6.

2. Use dos piezas de tornillos Allen (incluidos) M4 x 5 (S) para cerrar los orificios vacíos en el portaherramienta cuando se use refrigerante interno.

1. Always use carbide shank tools with h6 tolerance.

2. Use 2pcs. of M4 x 5 (S) hex. screw (included) to close air holes on the chuck when internal coolant is used.

Tabla de dispositivos térmicos

Heating device chart

Dispositivo térmico Heating device	Portaherramienta - chuck	
	SRD0250A, SRD0312A	SRD0375A~SRD1500A
ISG3400	Sí - Yes	Sí - Yes
SRK-HA1, HB2	No	Sí - Yes

Ejemplo para Ordenar - Ordering Example

BT40 - SRS 12 A - 105

Interfaz y diámetro de husillo Shank size	Diámetro Interno I.D. (d)	Longitud de proyección Projection length (L)
--	------------------------------	---

Shrink Fit (Heavy Type)

- El método de contracción sujeta firmemente a una herramienta de corte al calentar y enfriar el portaherramienta. Alta precisión y mucha fuerza de sujeción. (Del tipo pesado)
- Shrinkage method clamps a cutting tool firmly by heating and cooling the chuck. High precision, rigidity and strong clamping force. (Heavy Type)

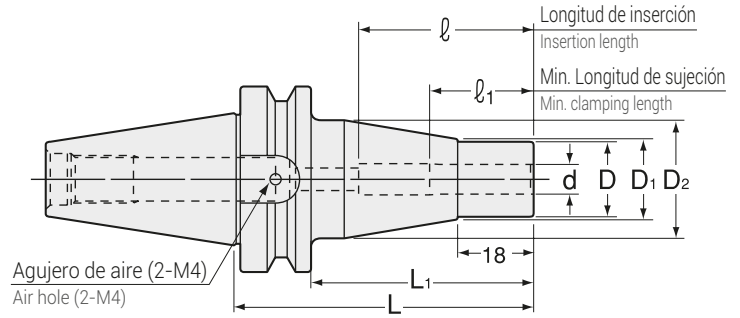
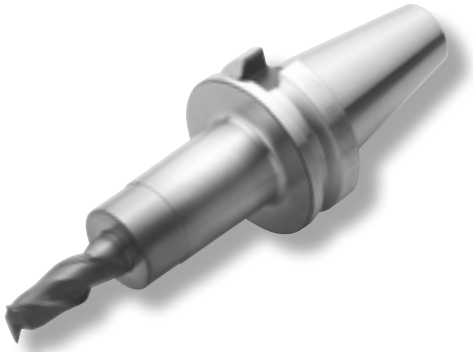

Medidas Métricas - Metric Sizes

Unidad : Métrico
Unit : Metric

Código Code	Modelo Model	d	L	L1	D	D1	D2	ℓ_1	ℓ	kg
3060 01206075	BT30 -SRK6A -75	6	75	53	16	17	30	26	26 ~ 36	0.8
3060 01208075	BT30 -SRK8A -75	8	75	53	19	20	32	26	26 ~ 50	0.8
3060 01110075	BT30 -SRK10A -75	10	75	53	24	25	34	32	32 ~ 50	0.9
3060 01112075	BT30 -SRK12A -75	12	75	53	28	29	34	37	37 ~ 70	0.9
3060 01116075	BT30 -SRK16A -75	16	75	53	32	33	34	40	40 ~ 80	0.9
3060 01306090	BT40 -SRK6A -90	6	90	63	16	17	30	26	26 ~ 36	1.4
3060 01308090	BT40 -SRK8A -90	8	90	63	19	20	32	26	26 ~ 50	1.4
3060 01310090	BT40 -SRK10A -90	10	90	63	24	25	34	32	32 ~ 50	1.5
3060 01312090	BT40 -SRK12A -90	12	90	63	28	29	34	37	37 ~ 70	1.5
3060 01316090	BT40 -SRK16A -90	16	90	63	32	33	34	40	40 ~ 80	1.5
3060 01320090	BT40 -SRK20A -90	20	90	63	36	37	46	42	42 ~ 100	1.7
3060 01325105	BT40 -SRK25A -105	25	105	78	46	47	50	48	48 ~ 110	2.0
3060 01506105	BT50 -SRK6A -105	6	105	67	16	17	30	26	26 ~ 36	3.7
3060 01508105	BT50 -SRK8A -105	8	105	67	19	20	32	26	26 ~ 50	3.7
3060 01510105	BT50 -SRK10A -105	10	105	67	24	25	34	32	32 ~ 50	3.9
3060 01512105	BT50 -SRK12A -105	12	105	67	28	29	34	37	37 ~ 70	3.9
3060 01516105	BT50 -SRK16A -105	16	105	67	32	33	34	40	40 ~ 80	3.9
3060 01520105	BT50 -SRK20A -105	20	105	67	36	37	46	42	42 ~ 100	4.1
3060 01525120	BT50 -SRK25A -120	25	120	82	46	47	53	48	48 ~ 110	4.4
3060 01532120	BT50 -SRK32A -120	32	120	82	56	57	70	51	51 ~ 120	5.2

1. Siempre use herramientas con zanco de carburo y con tolerancia dentro de h6.
2. Use dos piezas de tornillos hexagonales (incluidos) M4 x 5 (S) para cerrar los orificios vacíos en el portaherramienta cuando se use refrigerante interno.

1. Always use carbide shank tools with h6 tolerance.
2. Use 2pcs. of M4 x 5 (S) hex. screw (included) to close air holes on the chuck when internal coolant is used.

Tabla de dispositivos térmicos
Heating device chart

Dispositivo térmico Heating device	Portaherramienta - chuck	
	SRK6A, SRK8A	SRK10A~SRK32A
ISG3400	Sí-Yes	Sí-Yes *
SRK-HA1, HB2	No	Sí-Yes

*Se necesita de una bobina inductora especial. Diríjase a la pág. 486-487.

*Special induction coil is needed. Refer to P. 486-487.

Ejemplo para Ordenar - Ordering Example

BT40 - SRK 10 A - 90

Interfaz y diámetro de husillo Shank size	Diámetro Interno I.D. (d)	Longitud de proyección Projection length (L)
--	------------------------------	---

SYNCHROFIT II

- El diseño elástico único de NT Tool reduce el estrés en el machuelo y mejora la vida de la herramienta de corte
- NT Tools's unique elastic design reduces tapping stress and improves cutting tool life.

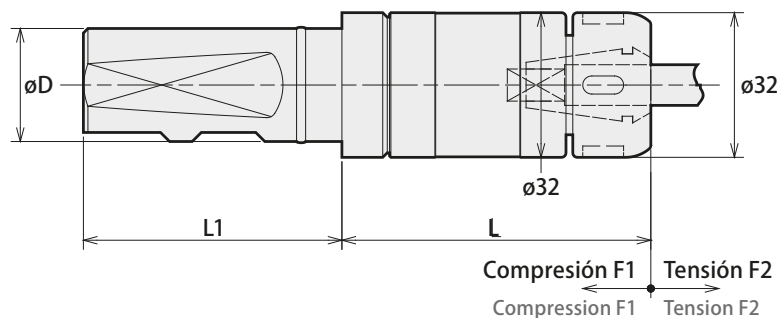

Código Code	Modelo Model	L	L1	D	Medida de machuelo Tap Size	Compresión F1 Compression F1	Tensión F2 Tension F2	Boquilla Collet	Tuerca ciega Nut	Llave Inglesa Spanner
0440 02016068	ST20D -SMH16 -68	68	51	20	M3~M12	0.1	0.1	ER16GH	ERP-16T	FKT-32L
0440 02516068	ST25D -SMH16 -68	68	56	25	U no.5~U7/16 PT1/8 • PT1/16					

1. La boquilla y Llave inglesa se venden por separado.
 2. Para la medida correspondiente al machuelo, consulte la pág. de dimensiones de las boquillas para machuelo.
 3. Utilice con una máquina con función sincrónica.
1. Collet and spanner are sold separately.
 2. For the corresponding tap size, refer to the tap collet dimension page.
 3. Please use with a machine with synchronous function.

Ejemplo para Ordenar - Ordering Example

ST20D - SMH16 - 68

Interfaz y diámetro de husillo

Shank size

Medida del portaherramineta

Holder size

Longitud de proyección

Projection length (L)

Boquilla Collet

Pág. 133



Llave Allen Spanner

Pág. 133



SYNCHROFIT II

- El diseño elástico y único de NT Tool, reduce el estrés en el machuelo y mejora la vida de la herramienta de corte.
- NT Tools's unique elastic design reduces tapping stress and improves cutting tool life.

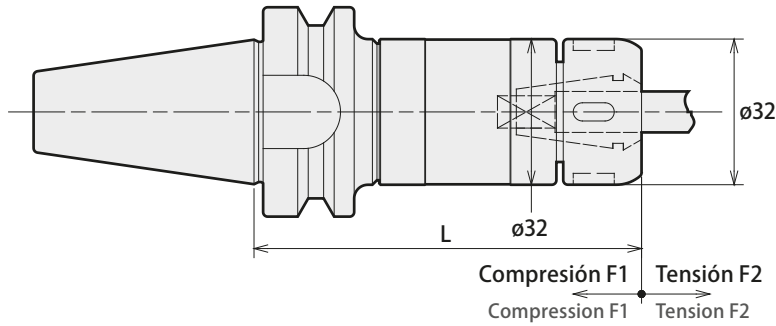

Código Code	Modelo Model	L	Medida de machuelo Tap Size	Compresión F1 Compression F1	Tensión F2 Tension F2	Boquilla Collet	Tuerca ciega Nut	Llave Inglesa Spanner
2450 00116090	BT30 -SMH16 -90	90	M3~M12	0.1	0.1	ER16GH	ERP-16T	FKT-32L
2450 00316090	BT40 -SMH16 -90	90	U no.5~U7/16 PT1/8•PT1/16					

1. La boquilla y Llave inglesa se venden por separado.
 2. Para la medida correspondiente al machuelo, consulte la pág. de dimensiones de las boquillas para machuelo.
 3. Utilice con una máquina con función sincrónica.
1. Collet and spanner are sold separately.
 2. For the corresponding tap size, refer to the tap collet dimension page.
 3. Please use with a machine with synchronous function.

Ejemplo para Ordenar - Ordering Example

BT30 - SMH16 - 90Interfaz y
diámetro
de husillo

Diámetro Interno

Longitud de
proyección

Shank size

I.D. (d)

Projection
length (L)Boquilla
Collet

Pág. 133

Llave Allen
Spanner

Pág. 133



Boquilla / collet

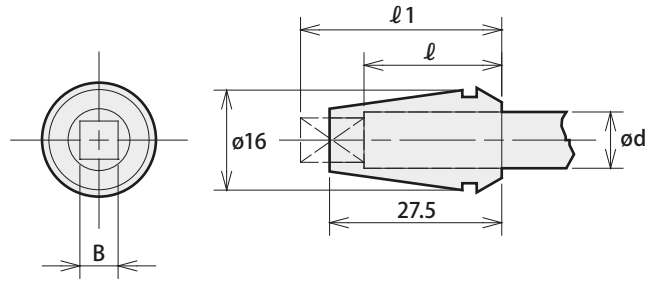

	Código Code	Modelo Model	ø d		B Sección del cuadro Square section		JIS Antiguo Old JIS	DIN371	DIN376	ℓ	Función de refrigerante por centro Center through		
											Sin Without		Con With
											ℓ1	Cantidad de ajuste (sin refrigerante) Adjustment amount (Without coolant)	ℓ1
mm	2464 16040030	ER16GH-4-3	4	3	—	M3.5	—	—	14	20	0	20	
	2464 16040032	ER16GH-4-3.2	4	3.2	M3	—	—	—	15	21	0	21	
	2464 16045034	ER16GH-4.5-3.4	4.5	3.4	—	M4	M6	—	15	21	0	21	
	2464 16050040	ER16GH-5-4	5	4	M4,M4.5	—	—	—	18	23~25	2	25	
	2464 16055043	ER16GH-5.5-4.3	5.5	4.3	—	—	M7	—	18	23~25	2	25	
	2464 16055045	ER16GH-5.5-4.5	5.5	4.5	M5,M5.5	—	—	—	18	23~25	2	25	
	2464 16060045	ER16GH-6-4.5	6	4.5	M6,U1/2	—	—	—	18	23~25	2	25	
	2464 16060049	ER16GH-6-4.9	6	4.9	—	M4.5~M6	M8	—	18	23~25	2	25	
	2464 16061050	ER16GH-6.1-5	6.1	5	U5/16	—	—	—	18	23~26	3	26	
	2464 16062050	ER16GH-6.2-5	6.2	5	M7,M8	—	—	—	18	23~26	3	26	
	2464 16070055	ER16GH-7-5.5	7	5.5	M9,M10,U3/8	M7	M9,M10	—	22	23~26	3	26	
	2464 16080060	ER16GH-8-6	8	6	M11,U7/16 PT1/8•PT1/16	—	—	—	22	27~31	4	31	
	2464 16080063	ER16GH-8-6.3	8	6.3	—	M8	M11	—	22	27~31	4	31	
	2464 16085065	ER16GH-8.5-6.5	8.5	6.5	M12	—	—	—	22	27~31	4	31	
2464 16090071	ER16GH-9-7.1	9	7.1	—	M9	M12	—	22	28~32	4	32		
	Código Code	Modelo Model	ø d		B Sección del cuadro Square section		ANSI		ℓ	Función de refrigerante por centro Center through			
										Sin Without		Con With	
										ℓ1	Cantidad de ajuste (sin refrigerante) Adjustment amount (Without coolant)	ℓ1	
Pulgada inch	2464 16168131	ER16GH-0.168	0.168	4.267	0.131	3.327	No 10	M5	15	21	0	21	
	2464 16194152	ER16GH-0.194	0.194	4.928	0.152	3.861	No 12	—	18	23~25	2	25	
	2464 16220165	ER16GH-0.220	0.220	5.588	0.165	4.191	1/4	M6	18	23~25	2	25	
	2464 16255191	ER16GH-0.255	0.255	6.477	0.191	4.851	5/16	M7	18	23~26	3	26	
	2464 16318238	ER16GH-0.318	0.318	8.077	0.238	6.045	—	M8	22	27~31	4	31	

- Al utilizar vena de lubricación interna, debe insertar el machuelo hasta que toque el fondo de la boquilla. Pueden ocurrir fugas de refrigerante si no se coloca correctamente.
 - Revisar las dimensiones del zanco y cuadro del machuelo al momento de seleccionar la boquilla.
- When using the center through, please insert the tap until it hits the bottom of the collet. Coolant leakage occurs if not correctly inserted.
 - Please check the dimensions of the shank and square of the tap when selecting the correct collet.

Tuerca ciega / Nut

Código Code	Modelo Model
2451 00001607	ERP-16T

Llave Inglesa / Spanner

Código Code	Modelo Model
2454 00000032	FKT-32L

Synchronous Tap Holder With Easy Tool Length Adjustment

- La longitud de proyección de la herramienta de corte se puede ajustar simplemente girando el anillo ubicado en la circunferencia del portaherramienta.
- Projection length of the cutting tool can be adjusted by simply turning circumference of the holder.

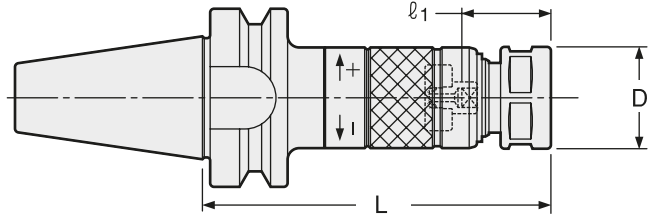
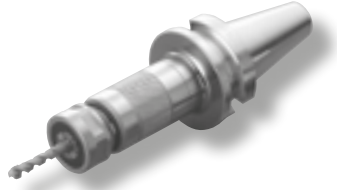

⚠ Para las medidas y capacidad de los machuelos, favor de dirigirse a la tabla en las pág. 485-486.
For capable tap sizes, please refer to P.485-486 chart.

(NOTA) El D.E. de la tuerca del STM8 es de 19 mm.
(NOTE) Nut O.D. of STM8 is 0.748".

Portaherramienta STM
STM Holder

+

Boquilla
Collet

+

Preajuste STS
STS Driver

Unidad : Métrico
Unit : Metric

Código Code	Modelo Model	Medida de machuelo Tap Size	L	D	Tuerca ciega Nut	kg	Boquilla Collet	Tornillo de preajuste Preset screw	Llave Inglesa Spanner
3910 00100075	BT30 -STM8 -75 *	Old JIS Taps	75	21	KDP-1414		FDC-07	STS-8	Llave con 17 mm de ancho (Flat 17mm width)
3910 00100090	-90	M4 ~ 8	90	21	KDP-1414				
3910 00100105	-105	U No8 ~ 5/16	105	21	KDP-1414				
3910 00100120	-120	OSG Synchro Taps	120	21	KDP-1414				
3910 00100135	-135	M4 ~ 6	135	21	KDP-1414				
3910 00100150	-150	M4 ~ 6	150	21	KDP-1414				
3910 10100075	BT30 -STM12 -75 *	Old JIS Taps	75	26	HTP-09	0.6	FSC-09	STS-12	S-1L
3910 10100090	-90	M4 ~ 12	90	26	HTP-09	0.6			
3910 10100105	-105	U No8 ~ 7/16 PT1/8	105	26	HTP-09	0.7			
3910 10100120	-120	OSG Synchro Taps	120	26	HTP-09	0.7			
3910 10100135	-135	M4 ~ 10	135	26	HTP-09	0.8			
3910 10100150	-150	M4 ~ 10	150	26	HTP-09	0.8			
3910 10100165	-165	M4 ~ 10	165	26	HTP-09				
3910 30100090	BT30 -STM18 -90	Old JIS Taps	90	36	HTP-16	0.7	FSC-16	STS-18	S-4L
3910 30100105	-105	M14 ~ 18	105	36	HTP-16	0.8			
3910 30100120	-120	U1/2 ~ 3/4 PT1/4 ~ 3/8	120	36	HTP-16				
3910 30100135	-135	OSG Synchro Taps	135	36	HTP-16				
3910 30100150	-150	M12 ~ 14	150	36	HTP-16				
3910 30100165	-165	M12 ~ 14	165	36	HTP-16				
3910 40100105	BT30 -STM30 -105	Old JIS Taps	105	46	HTP-22		FSC-22	STS-30	S-5L
3910 40100120	-120	M20 ~ 30	120	46	HTP-22	1.2			
3910 40100135	-135	U7/8 ~ 1-1/8 PT1/2 ~ 3/4	135	46	HTP-22				
3910 40100150	-150	OSG Synchro Taps	150	46	HTP-22				
3910 40100165	-165	M16 ~ 27	165	46	HTP-22				
3910 00300090	BT40 -STM8 -90	Old JIS Taps	90	21	KDP-1414	1.1	FDC-07	STS-8	Llave con 17 mm de ancho (Flat 17mm width)
3910 00300105	-105	M4 ~ 8	105	21	KDP-1414	1.1			
3910 00300120	-120	U No8 ~ 5/16	120	21	KDP-1414	1.2			
3910 00300135	-135	OSG Synchro Taps M4 ~ 6	135	21	KDP-1414	1.2			
3910 00300150	-150	M4 ~ 6	150	21	KDP-1414	1.2			
3910 10300090	BT40 -STM12 -90	Old JIS Taps	90	26	HTP-09	1.2	FSC-09	STS-12	S-1L
3910 10300105	-105	M4 ~ 12	105	26	HTP-09	1.2			
3910 10300120	-120	U No8 ~ 7/16 PT1/8	120	26	HTP-09	1.2			
3910 10300135	-135	OSG Synchro Taps	135	26	HTP-09	1.3			
3910 10300150	-150	M4 ~ 10	150	26	HTP-09	1.3			
3910 10300180	-180	M4 ~ 10	180	26	HTP-09	1.4			
3910 30300105	BT40 -STM18 -105	Old JIS Taps	105	36	HTP-16	1.4	FSC-16	STS-18	S-4L
3910 30300120	-120	M14 ~ 18	120	36	HTP-16	1.5			
3910 30300135	-135	U1/2 ~ 3/4 PT1/4 ~ 3/8	135	36	HTP-16	1.6			
3910 30300150	-150	OSG Synchro Taps	150	36	HTP-16	1.7			
3910 30300180	-180	M12 ~ 14	180	36	HTP-16				
3910 40300120	BT40 -STM30 -120	Old JIS Taps	120	46	HTP-22	1.7	FSC-22	STS-30	S-5L
3910 40300135	-135	M20 ~ 30 U7/8 ~ 1-1/8 PT1/2 ~ 3/4	135	46	HTP-22	1.8			
3910 40300150	-150	OSG Synchro Taps	150	46	HTP-22				
3910 40300180	-180	M16 ~ 27	180	46	HTP-22	2.4			
3910 00500090	BT50 -STM8 -90 *	Old JIS Taps	90	21	KDP-1414				
3910 00500105	-105	M4 ~ 8	105	21	KDP-1414				
3910 00500120	-120	U No8 ~ 5/16	120	21	KDP-1414				
3910 00500135	-135	OSG Synchro Taps	135	21	KDP-1414				
3910 00500150	-150	M4 ~ 6	150	21	KDP-1414				
3910 00500165	-165	M4 ~ 6	165	21	KDP-1414				
3910 10500090	BT50 -STM12 -90 *	Old JIS Taps	90	26	HTP-09		FSC-09	STS-12	S-1L
3910 10500105	-105	M4 ~ 12	105	26	HTP-09				
3910 10500120	-120	U No8 ~ 7/16 PT1/8	120	26	HTP-09				
3910 10500135	-135	OSG Synchro Taps	135	26	HTP-09				
3910 10500150	-150	M4 ~ 10	150	26	HTP-09	3.9			
3910 10500180	-180	M4 ~ 10	180	26	HTP-09				

Código Code	Modelo Model	Medida de machuelo Tap Size	L	D	Tuerca ciega Nut	kg	Boquilla Collet	Tornillo de preajuste Preset screw	Llave Inglesa Spanner
3910 30500105	BT50 -STM18 -105	Old JIS Taps	105	36	HTP-16		FSC-16	STS-18	S-4L
3910 30500120		M14 ~ 18	120	36	HTP-16				
3910 30500135		U1/2 ~ 3/4 PT1/4 ~ 3/8	135	36	HTP-16				
3910 30500150		OSG Synchro Tap	150	36	HTP-16				
3910 30500180	-180	M12 ~ 14	180	36	HTP-16				
3910 40500120	BT50 -STM30 -120	Old JIS Taps	120	46	HTP-22		FSC-22	STS-30	S-5L
3910 40500135		M20 ~ 30	135	46	HTP-22				
3910 40500150		U7/8 ~ 1-1/8 PT1/2 ~ 3/4	150	46	HTP-22	4.4			
3910 40500180		OSG Synchro Taps	180	46	HTP-22				
3910 40500210		M16 ~ 27	210	46	HTP-22				

- La boquilla, la llave inglesa y la unidad de preajuste se venden por separado.
- Favor de ver a continuación para conocer la dimensión ℓ_1 y ℓ_1^* .
- El STM8 puede hacer orificios de machueado menores a M4. Las boquillas a usar son como se especifica a continuación.
M1-M2.6: FDC-03007-*** M3-M3.5: FDC-04007-***
La unidad de preajuste no se usará para los usos antes mencionados.

- Collet, spanner and preset driver are sold separately.
- Please see below for ℓ_1 dimension*.
- Tap holes smaller than M4 can be made by STM8. Collets to be used are as follows.
M1-M2.6: FDC-03007-*** M3-M3.5: FDC-04007-***
Tap drive will not be used for the above usages.



Ejemplo para Ordenar - Ordering Example

BT50 - STM 18 - 120

Interfaz y diámetro de husillo
Shank size

Medida de portaherramienta
Holder size

Longitud de proyección
Projection length (L)

Boquilla Collet	Tornillo de preajuste Preset screw
Pág. 136-139	Pág. 136-137
	

Dimensión ℓ_1 para el STM - ℓ_1 Dimension for STM

Machuelos JIS antiguas - Old JIS Taps

Sin vena de refrigerante a través del centro - Without center-through coolant			Con vena de refrigerante a través del centro - With center-through coolant (STM12~30)		
Medida de machuelo - Tap Size	ℓ_1	ℓ_1 (*)	Medida de machuelo - Tap Size	ℓ_1	ℓ_1 (*)
M4 ~ 6 U No.8 ~ 1/4	21 ~ 35	21 ~ 26	M4 ~ 6 U No.8 ~ 1/4	24 ~ 35	24 ~ 26
M7 ~ 12 U 5/16 ~ U7/16 PT1/8	23 ~ 37	23 ~ 28	M7 ~ 10 U 5/16 ~ 3/8	25 ~ 37	25 ~ 28
M13 ~ 15 U 1/2 ~ 5/8 PT1/4	28 ~ 42	-	M11 ~ 12 U 7/16 PT 1/8	26 ~ 37	26 ~ 28
M16 ~ 17	32 ~ 45	-	U1/2	32 ~ 42	-
M18 ~ 27 U 3/4 ~ U1 PT3/8 ~ 5/8	33 ~ 47	-	M13 ~ 15 U9/16	33 ~ 42	-
M30 U1-1/8 PT3/4	38 ~ 52	-	U5/8 PT1/4	34 ~ 42	-
Con vena de refrigerante a través del centro - With center-through coolant (STM8)			M16	35 ~ 46	-
Medida de machuelo - Tap Size	ℓ_1	ℓ_1 (*)	M18	36 ~ 47	-
M4 ~ 6 U No.8 ~ 1/4	25 ~ 35	25 ~ 26	U 3/4 PT3/8	40 ~ 47	-
M7 ~ 8 U5/16	26 ~ 37	26 ~ 28	M20 ~ 21 PT1/2	41 ~ 47	-
Machuelos sincronizados OSG - OSG Synchro Taps			M22 U 7/8	42 ~ 47	-
Sin vena refrigerante a través del centro - Without center-through coolant			M23	43 ~ 47	-
Medida de machuelo - Tap Size	ℓ_1	ℓ_1 (*)	M24 ~ 25 PT5/8	44 ~ 47	-
M4 ~ 6	21 ~ 35	21 ~ 26	M26 ~ 27 U1	45 ~ 52	-
M8 ~ 10	23 ~ 37	23 ~ 28	M28	46 ~ 52	-
M12 ~ 14	28 ~ 42	-	M30	46 ~ 52	-
M16 ~ 27	33 ~ 47	-	PT3/4	48 ~ 52	-
Con vena de refrigerante a través del centro - With center-through coolant (STM8)			U 1-1/8	-	-
Medida de machuelo - Tap Size	ℓ_1	ℓ_1 (*)	YAMAWA X Series		
M4 ~ 6	25 ~ 35	25 ~ 26	Sin vena de refrigerante a través del centro - Without center-through coolant		
Con vena de refrigerante a través del centro - With center-through coolant (STM12~30)			Medida de machuelo - Tap Size	ℓ_1	ℓ_1 (*)
Medida de machuelo - Tap Size	ℓ_1	ℓ_1 (*)	M6 M8	23 ~ 37	23 ~ 28
M4 ~ 6	25 ~ 35	25 ~ 26	M10 M12	28 ~ 42	-
Con vena de refrigerante a través del centro - With center-through coolant (STM12~30)			Con vena de refrigerante a través del centro - With center-through coolant (STM8)		
Medida de machuelo - Tap Size	ℓ_1	ℓ_1 (*)	Medida de machuelo - Tap Size	ℓ_1	ℓ_1 (*)
M4 ~ 6	24 ~ 35	24 ~ 26	M6	26 ~ 37	26 ~ 28
M8 ~ 10	26 ~ 37	26 ~ 28	Con vena de refrigerante a través del centro - With center-through coolant (STM12~30)		
M12	33 ~ 42	-	Medida de machuelo - Tap Size	ℓ_1	ℓ_1 (*)
M14	34 ~ 42	-	M6	25 ~ 37	25 ~ 28
M16 ~ 20	40 ~ 46	-	M8	26 ~ 37	26 ~ 28
M22 ~ 27	44 ~ 47	-	M10	33 ~ 42	-
			M12	34 ~ 42	-

Tabla de referencia de las medidas de machuelo (boquilla, conductor de preajuste)

Tap size reference chart (collet, preset driver)

FDC 07 ó/ or FSC - boquilla (collet)

Unidad de cambio del conductor de preajuste y herramienta
Preset driver & tool for changing driver

Tipo OH - Type OH

● La boquilla OH debe usarse para el abastecimiento de refrigerante a través del centro y para el abastecimiento de refrigerante externo.

● OH type collet should be used for center-through coolant feeding and external coolant feeding.

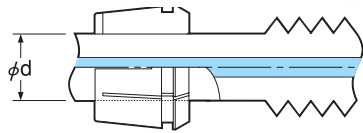

Tipo C - Type C

● Cuando se necesita el abastecimiento de refrigerante "a través de los costados de la boquilla"

● when "collet-through" coolant feeding is needed.

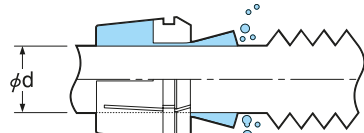

Tipo STS - Type STS

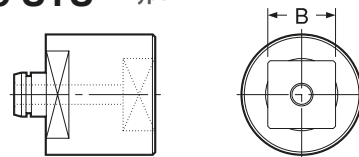

Tipo STS-R - Type STS

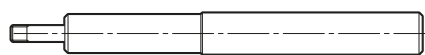

Favor de elegir el tipo OH para un uso sin refrigerante.

Please select OH type for non-coolant use.

Modelo de portaherramienta Holder Model	Medida de machuelo - Tap Size					ød	Modelo de Boquilla Collet Model (OH or C)	B	Conductor de preajuste Preset Driver	Herramienta para cambiar el conductor preajustado Tool for Changing Driver	
	Machuelo JIS antiguas - Old JIS Taps			Machuelos de roscar sincronizados de OSG - OSG Synchro-Taps	YAMAHA X Series						
	Rosca métrica Metric Thread	Rosca unificada Unified Thread	Rosca de zanco tubular Pipe Taper Thread								
STM8	M4~M4.5	UNo.8				5.0	FDC-05007-**	4.0	STS8-□4.0	STS-R0	
	M5~M5.5	UNo.10~12				5.5	FDC-05507-**	4.5	STS8-□4.5	STS-R0	
	M6	U1/4		M4~M6	M6	6.0	FDC-06007-**	4.5	STS8-□4.5	STS-R0	
						6.0	FDC-06007-**	4.9	STS8-□4.9	STS-R0	
			U5/16			6.1	FDC-06107-**	5.0	STS8-□5.0	STS-R0	
		M7~8				6.2	FDC-06207-**	5.0	STS8-□5.0	STS-R0	
STM12	M4~M4.5	UNo.8				5.0	FSC-09-5.0-**	4.0	STS12-□4.0	STS-R1	
	M5~M5.5	UNo.10~12				5.5	FSC-09-5.5-**	4.5	STS12-□4.5	STS-R1	
	M6	U1/4		M4~M6	M6	6.0	FSC-09-6.0-**	4.5	STS12-□4.5	STS-R1	
						6.0	FSC-09-6.0-**	4.9	STS12-□4.9	STS-R1	
			U5/16			6.1	FSC-09-6.1-**	5.0	STS12-□5.0	STS-R1	
		M7~8				6.2	FSC-09-6.2-**	5.0	STS12-□5.0	STS-R1	
		M9~M10	U3/8			7.0	FSC-09-7.0-**	5.5	STS12-□5.5	STS-R1	
					M8	8.0	FSC-09-8.0-**	6.2	STS12-□6.2	STS-R1	
		M11	U7/16	PT1/16~1/8	M8~M10	8.0	FSC-09-8.0-**	6.0	STS12-□6.0	STS-R1	
		M12				8.5	FSC-09-8.5-**	6.5	STS12-□6.5	STS-R1	
STM18		U1/2				9.0	FSC-16-9.0-**	7.0	STS18-□7.0	STS-R2	
	M13					9.5	FSC-16-9.5-**	7.0	STS18-□7.0	STS-R2	
				M12	M10	10.0	FSC-16-10.0-**	8.0	STS18-□8.0	STS-R2	
	M14~15	U9/16				10.5	FSC-16-10.5-**	8.0	STS18-□8.0	STS-R2	
			PT1/4			11.0	FSC-16-11.0-**	9.0	STS18-□9.0	STS-R2	
			U5/8		M14	M12	12.0	FSC-16-12.0-**	9.0	STS18-□9.0	STS-R2
		M16				12.5	FSC-16-12.5-**	10.0	STS18-□10.0	STS-R2	
		M17				13.0	FSC-16-13.0-**	10.0	STS18-□10.0	STS-R2	
		M18~M19	U3/4	PT3/8		14.0	FSC-16-14.0-**	11.0	STS18-□11.0	STS-R2	
		M20				15.0	FSC-22-15.0-**	12.0	STS30-□12.0	STS-R2	
STM30	M21			M16~M20		16.0	FSC-22-16.0-**	12.0	STS30-□12.0	STS-R2	
	M22	U7/8				17.0	FSC-22-17.0-**	13.0	STS30-□13.0	STS-R2	
	M23		PT1/2			18.0	FSC-22-18.0-**	14.0	STS30-□14.0	STS-R2	
	M24~M25		PT5/8			19.0	FSC-22-19.0-**	15.0	STS30-□15.0	STS-R2	
	M26~M27	U1		M22~M27		20.0	FSC-22-20.0-**	15.0	STS30-□15.0	STS-R2	
	M28					21.0	FSC-22-21.0-**	17.0	STS30-□17.0	STS-R2	
			U1-1/8			22.0	FSC-22-22.0-**	17.0	STS30-□17.0	STS-R2	
		M30		PT3/4		23.0	FSC-22-23.0-**	17.0	STS30-□17.0	STS-R2	

Ejemplo para Ordenar - Ordering Example

FSC - 22 - 20.0 - OH

Medida de la boquilla
Collet size

D.I. de la boquilla
Collet I.D. (d)

OH: Para herramienta con vena de lubricación

C: Para refrigeración a través de los costados de la boquilla

OH: For tool with coolant hole

C: For collet through

Combinación de accesorios - Accessories combination

Portaherramienta para machuelo - Tap holder	Boquilla Collet	Conductor de preajuste Preset driver		Tuerca ciega Nut		Unidad de cambio de herramienta Tool changing driver		Llave Inglesa Spanner	
Modelo Model	Modelo Model	Modelo Model	Código Code	Modelo Model	Código Code	Modelo Model	Código Code	Modelo Model	Código Code
STM8	FDC-07	STS8	3914 0100**03	KDP-144	0070 01001407	STS-R0	3914 00000006	Llave con 17 mm de ancho (Flat 17mm width)	
STM12	FSC-09	STS12	3914 1100**03	HTP-09	1314 00000009	STS-R1	3914 10000006	S-1L	0803 00000011
STM18	FSC-16	STS18	3914 310***03	HTP-16	1314 00000016	STS-R2	3914 30000006	S-4L	0803 00000014
STM30	FSC-22	STS30	3914 410***03	HTP-22	1314 00000022	STS-R2	3914 30000006	S-5L	0803 00000015

Pulgada a métrico → Pulgada × 25.4

Métrico a pulgada → Métrico ÷ 25.4 ó métrico por 0.03937



Tamaños especiales / personalizados bajo pedido

Tabla de referencia de las medidas del machuelo (boquilla, conductor de preajuste)

Tap size reference chart (collet, preset driver)

FDC 07 ó/or FSC - boquilla (collet)

Unidad de cambio del conductor de preajuste y herramienta
Preset driver & tool for changing driver

Tipo OH - Type OH

● La boquilla OH debe usarse para el abastecimiento de refrigerante a través del centro y para el abastecimiento de refrigerante externo.

● OH type collet should be used for center-through coolant feeding and external coolant feeding.

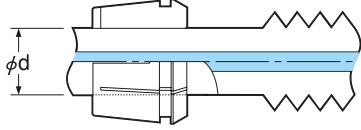

Tipo C - Type C

● Cuando se necesita el abastecimiento de refrigerante "a través de la boquilla"

● when "collet-through" coolant feeding is needed.

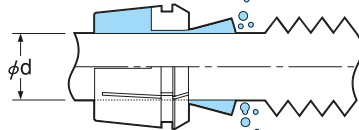

Tipo STS - Type STS

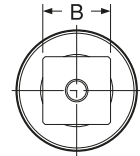
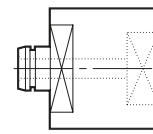

Tipo STS-R - Type STS

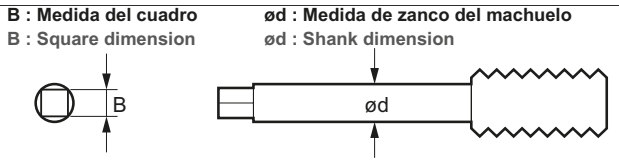
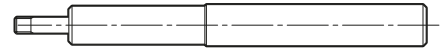

Favor de elegir el tipo OH para un uso sin refrigerante.
Please select OH type for non-coolant use.

Modelo de portaherramienta Holder Model	Medida de machuelo Tap Size (ANSI)	ød (Pulgadas - Inch)	ød (mm)	Modelo de Boquilla Collet Model (OH or C)	B (pulgadas - inch)	B (mm)	Conductor de preajuste Preset Driver
STM8	#0-6	0.141	3.5814	FDC-03607**	0.110	2.794	STS8-□ 2.8
	#8	0.168	4.2672	FDC-04307**	0.131	3.3274	STS8-□ 3.4
	#10	0.194	4.9276	FDC-05007**	0.152	3.8608	STS8-□ 4.0
	#12	0.22	5.588	FDC-05607**	0.165	4.191	STS8-□ 4.2
	1/4	0.255	6.477	FDC-06507**	0.191	4.8514	STS8-□ 5.0
STM12	#0-6	0.141	3.5814	FSC-09-3.6**	0.110	2.794	STS12-□ 2.8
	#8	0.168	4.2672	FSC-09-4.3**	0.131	3.3274	STS12-□ 3.4
	#10	0.194	4.9276	FSC-09-5.0**	0.152	3.8608	STS12-□ 4.0
	#12	0.22	5.588	FSC-09-5.6**	0.165	4.191	STS12-□ 4.2
	1/4	0.255	6.477	FSC-09-6.5**	0.191	4.8514	STS12-□ 5.0
	1/8SPT	0.313	7.9502	FSC-09-8.0**	0.234	5.9436	STS12-□ 6.0
	5/16	0.318	8.0772	FSC-09-8.1**	0.238	6.0452	STS12-□ 6.1
STM18	7/16	0.323	8.2042	FSC-09-8.3**	0.242	6.1468	STS12-□ 6.2
	1/2	0.367	9.3218	FSC-16-9.4**	0.275	6.985	STS18-□ 7.0
	3/8	0.381	9.6774	FSC-16-9.7**	0.286	7.2644	STS18-□ 7.3
	9/16	0.429	10.8966	FSC-16-10.9**	0.322	8.1788	STS18-□ 8.2
	1/8LPT	0.437	11.0998	FSC-16-11.1**	0.328	8.3312	STS18-□ 8.4
	5/8	0.48	12.192	FSC-16-12.2**	0.360	9.144	STS18-□ 9.2
	11/16	0.542	13.7668	FSC-16-13.8**	0.406	10.3124	STS18-□ 10.4
STM30	1/4PT	0.562	14.2748	FSC-16-14.3**	0.421	10.6934	STS18-□ 10.7
	3/4	0.59	14.986	FSC-22-15.0**	0.442	11.2268	STS30-□ 11.3
	13/16	0.652	16.5608	FSC-22-16.6**	0.489	12.4206	STS30-□ 12.5
	7/8	0.697	17.7038	FSC-22-17.8**	0.523	13.2842	STS30-□ 13.3
	3/8PT	0.7	17.78	FSC-22-17.8**	0.531	13.4874	STS30-□ 13.5
	1	0.8	20.32	FSC-22-20.4**	0.600	15.24	STS30-□ 15.3

Para DIN e ISO, favor de dirigirse a la pág. 450-451.
For DIN and ISO, please refer to P.450-451.

Ejemplo para Ordenar - Ordering Example

FSC - 22 - 20.4 - OH

Medida de la boquilla
Collet size

D.I. de la boquilla
Collet I.D. (d)

OH: Para herramienta con vena de refrigerante

C: Para refrigerante a través de los costados de la boquilla

OH: For tool with coolant hole

C: For collet through

Combinación de accesorios - Accessories combination

Portaherramienta para machuelo - Tap holder	Boquilla Collet	Conductor de preajuste Preset driver		Tuerca ciega Nut		Unidad de cambio de herramienta Tool changing driver		Llave Inglesa Spanner	
Modelo Model	Modelo Model	Modelo Model	Código Code	Modelo Model	Código Code	Modelo Model	Código Code	Modelo Model	Código Code
STM8	FDC-07	STS8	3914 0100**03	KDP-1414	0070 01001407	STS-R0	3914 00000006	Llave con 17 mm de ancho (Flat 17mm width)	
STM12	FSC-09	STS12	3914 1100**03	HTP-09	1314 00000009	STS-R1	3914 10000006	S-1L	0803 00000011
STM18	FSC-16	STS18	3914 310***03	HTP-16	1314 00000016	STS-R2	3914 30000006	S-4L	0803 00000014
STM30	FSC-22	STS30	3914 410***03	HTP-22	1314 00000022	STS-R2	3914 30000006	S-5L	0803 00000015

Pulgada a métrico → Pulgada × 25.4
Métrico a pulgada → Métrico ÷ 25.4 ó métrico por 0.03937



Tamaños especiales / personalizados bajo pedido

Boquilla para machuelo - Collet For Tapper

FSC-OH

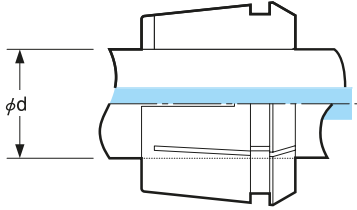
Para herramienta con vena para refrigerante
For tool with coolant hole

FSC-C

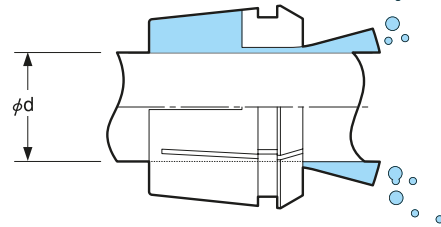
Para refrigerante a través de la boquilla
For Collet through

Diá. del zanco de la herramienta - Tool Shank Dia.		Medida Size	Código Code
ød (inch)	ød (mm)		
ø 0.141	ø 3.6	FSC-09-3.6-OH	—
ø 0.168	ø 4.3	FSC-09-4.3-OH	1334 00104309
ø 0.194	ø 5.0	FSC-09-5.0-OH	1334 00105009
ø 0.220	ø 5.6	FSC-09-5.6-OH	1334 00105609
ø 0.216	ø 5.5	FSC-09-5.5-OH	1334 00105509
ø 0.236	ø 6.0	FSC-09-6.0-OH	1334 00106009
ø 0.240	ø 6.1	FSC-09-6.1-OH	1334 00106109
ø 0.244	ø 6.2	FSC-09-6.2-OH	1334 00106209
ø 0.255	ø 6.5	FSC-09-6.5-OH	1334 00106509
ø 0.275	ø 7.0	FSC-09-7.0-OH	1334 00107009
ø 0.314	ø 8.0	FSC-09-8.0-OH	1334 00108009
ø 0.313	ø 8.0	FSC-09-8.0-OH	1334 00108009
ø 0.318	ø 8.1	FSC-09-8.1-OH	1334 00108109
ø 0.323	ø 8.3	FSC-09-8.3-OH	1334 00108309
ø 0.334	ø 8.5	FSC-09-8.5-OH	1334 00108509
ø 0.354	ø 9.0	FSC-16-9.0-OH	1334 00109016
ø 0.367	ø 9.4	FSC-16-9.4-OH	1334 00109416
ø 0.374	ø 9.5	FSC-16-9.5-OH	1334 00109516
ø 0.381	ø 9.7	FSC-16-9.7-OH	1334 00109716
ø 0.393	ø 10.0	FSC-16-10.0-OH	1334 00110016
ø 0.413	ø 10.5	FSC-16-10.5-OH	1334 00110516
ø 0.429	ø 10.9	FSC-16-10.9-OH	1334 00110916
ø 0.433	ø 11.0	FSC-16-11.0-OH	1334 00111016
ø 0.437	ø 11.1	FSC-16-11.1-OH	1334 00111116
ø 0.472	ø 12.0	FSC-16-12.0-OH	1334 00112016
ø 0.480	ø 12.2	FSC-16-12.2-OH	1334 00112216
ø 0.492	ø 12.5	FSC-16-12.5-OH	1334 00112516
ø 0.511	ø 13.0	FSC-16-13.0-OH	1334 00113016
ø 0.542	ø 13.8	FSC-16-13.8-OH	1334 00113816
ø 0.551	ø 14.0	FSC-16-14.0-OH	1334 00114016
ø 0.562	ø 14.3	FSC-16-14.3-OH	1334 00114316
ø 0.590	ø 15.0	FSC-22-15.0-OH	1334 00115022
ø 0.629	ø 16.0	FSC-22-16.0-OH	1334 00116022
ø 0.652	ø 16.6	FSC-22-16.6-OH	1334 00116622
ø 0.669	ø 17.0	FSC-22-17.0-OH	1334 00117022
ø 0.697	ø 17.8	FSC-22-17.8-OH	1334 00117822
ø 0.700	ø 17.8	FSC-22-17.8-OH	1334 00117822
ø 0.708	ø 18.0	FSC-22-18.0-OH	1334 00118022
ø 0.748	ø 19.0	FSC-22-19.0-OH	1334 00119022
ø 0.800	ø 20.4	FSC-22-20.4-OH	1334 00120422
ø 0.787	ø 20.0	FSC-22-20.0-OH	1334 00120022
ø 0.826	ø 21.0	FSC-22-21.0-OH	1334 00121022
ø 0.866	ø 22.0	FSC-22-22.0-OH	1334 00122022
ø 0.905	ø 23.0	FSC-22-23.0-OH	1334 00123022

Diá. del zanco de la herramienta - Tool Shank Dia.		Medida Size	Código Code
ød (inch)	ød (mm)		
ø 0.141	ø 3.6	FSC-09-3.6-C	—
ø 0.168	ø 4.3	FSC-09-4.3-C	1335 00104309
ø 0.194	ø 5.0	FSC-09-5.0-C	1335 00105009
ø 0.220	ø 5.6	FSC-09-5.6-C	1335 00105609
ø 0.216	ø 5.5	FSC-09-5.5-C	1335 00105509
ø 0.236	ø 6.0	FSC-09-6.0-C	1335 00106009
ø 0.240	ø 6.1	FSC-09-6.1-C	1335 00106109
ø 0.244	ø 6.2	FSC-09-6.2-C	1335 00106209
ø 0.255	ø 6.5	FSC-09-6.5-C	1335 00106509
ø 0.275	ø 7.0	FSC-09-7.0-C	1335 00107009
ø 0.314	ø 8.0	FSC-09-8.0-C	1335 00108009
ø 0.313	ø 8.0	FSC-09-8.0-C	1335 00108009
ø 0.318	ø 8.1	FSC-09-8.1-C	1335 00108109
ø 0.323	ø 8.3	FSC-09-8.3-C	1335 00108309
ø 0.334	ø 8.5	FSC-09-8.5-C	1335 00108509
ø 0.354	ø 9.0	FSC-16-9.0-C	1335 00109016
ø 0.367	ø 9.4	FSC-16-9.4-C	1335 00109416
ø 0.374	ø 9.5	FSC-16-9.5-C	1335 00109516
ø 0.381	ø 9.7	FSC-16-9.7-C	1335 00109716
ø 0.393	ø 10.0	FSC-16-10.0-C	1335 00110016
ø 0.413	ø 10.5	FSC-16-10.5-C	1335 00110516
ø 0.429	ø 10.9	FSC-16-10.9-C	1335 00110916
ø 0.433	ø 11.0	FSC-16-11.0-C	1335 00111016
ø 0.437	ø 11.1	FSC-16-11.1-C	1335 00111116
ø 0.472	ø 12.0	FSC-16-12.0-C	1335 00112016
ø 0.480	ø 12.2	FSC-16-12.2-C	1335 00112216
ø 0.492	ø 12.5	FSC-16-12.5-C	1335 00112516
ø 0.511	ø 13.0	FSC-16-13.0-C	1335 00113016
ø 0.542	ø 13.8	FSC-16-13.8-C	1335 00113816
ø 0.551	ø 14.0	FSC-16-14.0-C	1335 00114016
ø 0.562	ø 14.3	FSC-16-14.3-C	1335 00114316
ø 0.590	ø 15.0	FSC-22-15.0-C	1335 00115022
ø 0.629	ø 16.0	FSC-22-16.0-C	1335 00116022
ø 0.652	ø 16.6	FSC-22-16.6-C	1335 00116622
ø 0.669	ø 17.0	FSC-22-17.0-C	1335 00117022
ø 0.697	ø 17.8	FSC-22-17.8-C	1335 00117822
ø 0.700	ø 17.8	FSC-22-17.8-C	1335 00117822
ø 0.708	ø 18.0	FSC-22-18.0-C	1335 00118022
ø 0.748	ø 19.0	FSC-22-19.0-C	1335 00119022
ø 0.800	ø 20.4	FSC-22-20.4-C	1335 00120422
ø 0.787	ø 20.0	FSC-22-20.0-C	1335 00120022
ø 0.826	ø 21.0	FSC-22-21.0-C	1335 00121022
ø 0.866	ø 22.0	FSC-22-22.0-C	1335 00122022
ø 0.905	ø 23.0	FSC-22-23.0-C	1335 00123022

Se deberá elegir el tipo OH en caso de que no se use el refrigerante a través del husillo de la máquina.

OH type shall be selected in case not utilizing coolant through from the machine spindle.

Ejemplo para Ordenar - Ordering Example

FSC - 16 - 9.0 - OH
 Series 16 Diá. del zanco de la herramienta
 16 Series Tool Shank Dia.

Ejemplo para Ordenar - Ordering Example

FSC - 16 - 9.0 - C
 Series 16 Diá. del zanco de la herramienta.
 16 Series Tool Shank Dia.

FSC-MS

Boquilla de alta precisión para machuelo (para mecanizado semiseco/MQL)

High-Precision Collet for Tapper (For Semidry Machining /MQL)

- Hace que el lubricante se adhiera a la superficie de la pieza de trabajo y de la herramienta al rociar partículas comparativamente grandes junto a la herramienta.
- Making lubricant adhere to the surface of workpiece and tool by spraying comparatively large particles alongside the tool.

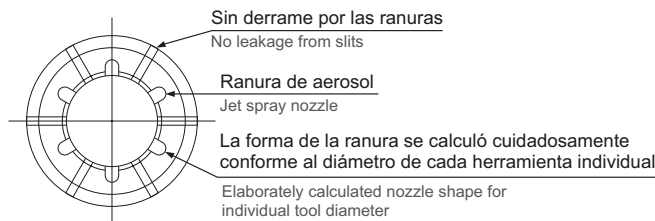
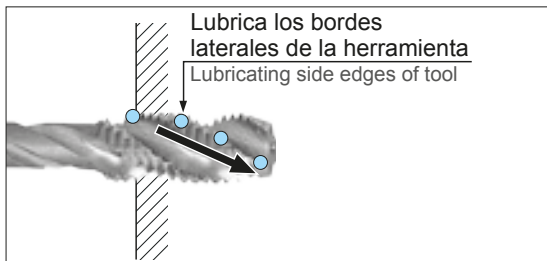
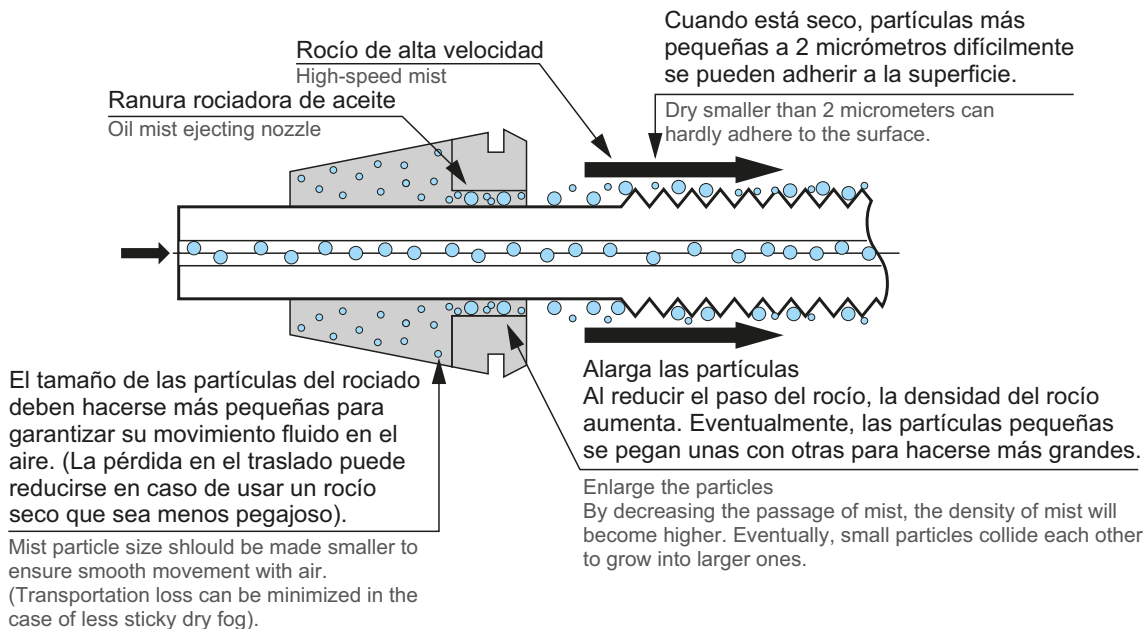

Diá. del zanco de la herramienta - Tool Shank Dia.	Modelo - Model	
	FSC-MS	
	Medida - Size	Código - Code
ø 5.0	FSC-09-5.0-MS	1336 00105009
ø 5.5	FSC-09-5.5-MS	1336 00105509
ø 6.0	FSC-09-6.0-MS	1336 00106009
ø 6.1	FSC-09-6.1-MS	1336 00106109
ø 6.2	FSC-09-6.2-MS	1336 00106209
ø 7.0	FSC-09-7.0-MS	1336 00107009
ø 8.0	FSC-09-8.0-MS	1336 00108009
ø 8.5	FSC-09-8.5-MS	1336 00108509
ø 9.0	FSC-16-9.0-MS	1336 00109016
ø 9.5	FSC-16-9.5-MS	1336 00109516
ø 10.0	FSC-16-10.0-MS	1336 00110016
ø 10.5	FSC-16-10.5-MS	1336 00110516
ø 11.0	FSC-16-11.0-MS	1336 00111016

Diá. del zanco de la herramienta - Tool Shank Dia.	Modelo - Model	
	FSC-MS	
	Medida - Size	Código - Code
ø 12.0	FSC-16-12.0-MS	1336 00112016
ø 12.5	FSC-16-12.5-MS	1336 00112516
ø 13.0	FSC-16-13.0-MS	1336 00113016
ø 14.0	FSC-16-14.0-MS	1336 00114016
ø 15.0	FSC-22-15.0-MS	1336 00115022
ø 16.0	FSC-22-16.0-MS	1336 00116022
ø 17.0	FSC-22-17.0-MS	1336 00117022
ø 18.0	FSC-22-18.0-MS	1336 00118022
ø 19.0	FSC-22-19.0-MS	1336 00119022
ø 20.0	FSC-22-20.0-MS	1336 00120022
ø 21.0	FSC-22-21.0-MS	1336 00121022
ø 22.0	FSC-22-22.0-MS	1336 00122022
ø 23.0	FSC-22-23.0-MS	1336 00123022

1. La boquilla se reduce en rangos de 0.1 mm.
2. Las medidas que no se enlistaron previamente sólo están disponibles bajo pedido.
3. Se pueden usar herramientas con o sin orificios para refrigerante.

1. Collets collapse by 0.1mm.
2. Sizes not listed above are available upon request.
3. Tools with or without coolant holes can be used.

Ejemplo para Ordenar - Ordering Example

FSC - 09 - 5.0 - MS

Series 09

09 Series

Diá. del zanco de la herramienta

Tool Shank Dia.

STP

Synchro Tapping Chuck

- Adaptador de machuelo de cambio rápido
- Quick-changeable tap adapter.

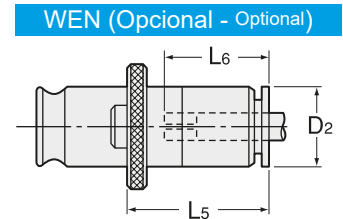
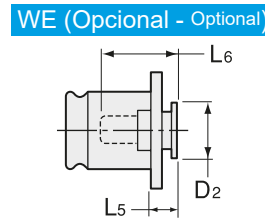
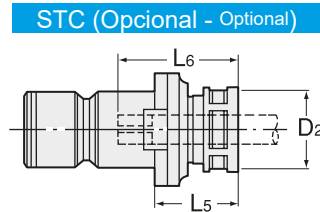
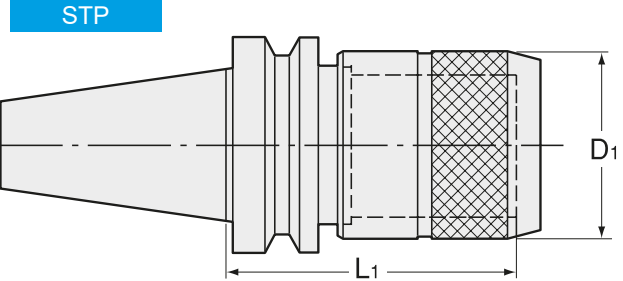

⚠ Para consultar la medida en pulgadas del machuelo diríjase a la pág. 450.
For Inch size tap, please refer to P. 450.

Unidad : Métrico
Unit : Metric

Código Code	Modelo Model	L1	D1	kg	Adaptador de machuelo Tap adapter	L5	D2	Medida de machuelo - Tap Size			
								Rosca métrica Metric thread	Machuelo sincronizado de OSG - OSG synchro tap	Machuelo tubular Pipe tap	ANSI
2780 01001065	BT30 -STP1 -65	65	38	0.6	STC1- ***	26	26	M3 ~ M12	M3 ~ M10	PIPE (PT,PS,PF) 1/8	#8-12, 1/4, 5/16, 7/16, 1/8SS
					WEN1B- ***	33	19				
					WE1- ***	7	19				
2780 03001065	BT40 -STP1 -65	65	38	1.2	STC1- ***	26	26	M3 ~ M12	M3 ~ M10	PIPE (PT,PS,PF) 1/8	#8-12, 1/4, 5/16, 7/16, 1/8SS
					WEN1B- ***	33	19				
2780 03001095	-95	95	38	1.4	WE1- ***	7	19	M8 ~ M20	M8 ~ M14	PIPE (PT,PS,PF) 1/8 PIPE (PT,PS,PF) 1/4 PIPE (PT,PS,PF) 3/8	1/4-3/4, 1/8SS, 1/8SL, 1/4P
2780 03002085	BT40 -STP2 -85	85	55	1.5	STC2- ***	35	36				
2780 03002115	-115	115	55	2.0	WE2- ***	11	30	M3 ~ M12	M3 ~ M10	PIPE (PT,PS,PF) 1/8	#8-12, 1/4, 5/16, 7/16, 1/8SS
2780 05001080	BT50 -STP1 -80	80	38	3.8	STC1- ***	26	26				
2780 05001110	-110	110	38	4.2	WE1- ***	7	19	M8 ~ M20	M8 ~ M14	PIPE (PT,PS,PF) 1/8 PIPE (PT,PS,PF) 1/4 PIPE (PT,PS,PF) 3/8	1/4-3/4, 1/8SS, 1/8SL, 1/4P
2780 05002100	BT50 -STP2 -100	100	55	4.2	STC2- ***	35	36				
2780 05002130	-130	130	55	4.8	WE2- ***	11	30				

Los valores L5 se usan en caso de usar una rosca métrica.
L5 values are in the case of metric thread.

Favor de dirigirse a la pág. 445 para consultar la dimensión L6 del WE.
Favor de dirigirse a la pág. 447 para consultar la dimensión L6 del WEN.

STC L6 Dimensiones - Dimension

Please refer to P. 445 for L6 dimension of WE.
Please refer to P. 447 for L6 dimension of WEN.

Unidad : Métrico
Unit : Metric

STC1 L6	M3	M4	M5	M6	M8	M10	M11	M12	Tubo - Pipe1/8
MIN	24	26	31	31	32	32	32	33	34
MAX	29	31	35	35	37	37	37	37	38

Unidad : Métrico
Unit : Metric

STC2 L6	M8	M10	M11	M12	M14	M16	M17	M18	M20	Tubo - Pipe1/8	Tubo - Pipe1/4	Tubo - Pipe3/8
MIN	34	34	33	35	39	41	41	43	43	29	29	33
MAX	39	39	38	40	44	46	46	48	48	33	31	34

Código Code	Modelo Model	Boquilla - Collet			Tuerca ciega Nut	Llave Inglesa Spanner
		Rosca métrica Metric thread	Machuelo tubular Pipe tap	Machuelo sincronizado de OSG - OSG synchro tap		
2800 00001 ※※※	STC1- ※※※	FDC-09		FDC-09	HDP-09B	S-1L
2800 00001 ※※※	STC1- ※※※		ESC10		KDP-1916	S-1L
2800 00002 ※※※	STC2- ※※※	FDC-16		FDC-16	HDP-16B	S-4L
2800 00002 ※※※	STC2- ※※※		ESC16		KDP-2825	S-4L

- La medida del machuelo se insertará en " ※※※ ".
 - El adaptador STC viene completo con boquilla y tuerca ciega, pero la llave inglesa se vende por separado.
 - Favor de especificar si usa el machuelo sincronizado OSG.
Por ejemplo: STC1-M3-O
 - El STP se puede usar para abastecer con refrigerante a través del centro con el FDC-OH o la boquilla C (P. 083-084) y el adaptador STC.
- Tap size will be inserted in " ※※※ ".
 - STC adapter comes complete with collet and nut, but spanner is sold separately.
 - When using OSG synchro tap, please specify it.
Example : STC1-M3-O
 - With FDC-OH or C collet (p.083-084) and STC Adapter, STP can be used for center-thru coolant.

Portaherramienta STP
Holder STP

Ejemplo para Ordenar - Ordering Example

BT40	-	STP1	-	95
Interfaz y diámetro de husillo Shank size		Medida del adaptador Adapter size		L1

Adaptador STC
adapter STC

Ejemplo para Ordenar - Ordering Example

STC1	-	M10
Tamaño Size		Medida de machuelo Tap size

Adaptador de machuelo WEN•B BILZ
Tap Adapter WEN•B BILZ

Ejemplo para Ordenar - Ordering Example

WEN1B	-	M10
Tamaño Size		Medida de machuelo Tap size

WE Adaptador de machuelo
Tap adapter WE

Pág.480

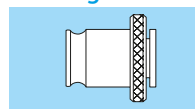

WEN Adaptador de machuelo
Tap adapter WEN

Pág.482

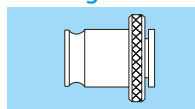

Llave Inglesa
Spanner

Pág.099



- BT
- CAT
- AHO
- HSK-A/E/F/C
- HSK-T
- C
- UTS
- Máquinas Especializadas
Specialized Machine
- Equipo Relacionado
Related Equipment
- Taladro de Biselado & Casquillo
Bush & Chamfering Drill
- Milling Chuck
- Collet Holder
- "R" Zero Holder
- Hydraulic Chuck
- Shrink Fit
- Tapping Chuck
- Arbors
- Function Holder
- Turning Tool
- Retention Stud
- Tool Shank Dimensions

TP1

Quick Change Tapping Chuck

- La fuerte compresión permite el uso con machuelos incorporados.
- Strong compression allows use with rolled thread tap.

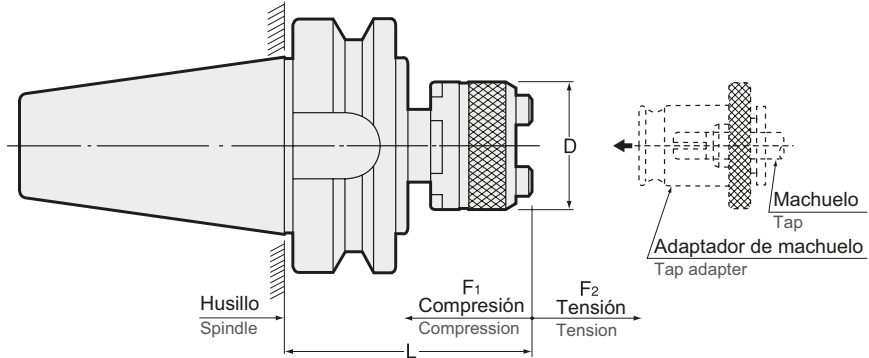

! Para consultar la medida en pulgadas del machuelo, diríjase a la pág. 486.
For Inch size tap, please refer to P. 486.

Medidas Métricas - Metric Sizes

Unidad : Métrico
Unit : Metric

Código Code	Modelo Model	Medida de machuelo Tap Size	Medida del adaptador Adapter size	L	D	Compensación axial - Axial compensation		kg
						F1	F2	
2250 30010057	BT30 -TP1 -1 -57	M3 ~ M12,U1/4 ~ U7/16, PIPE (PT,PS,PF) 1/8	1	57	32	6	18	0.5
2250 30020095	BT30 -TP1 -2 -95	M8 ~ M22,U3/8 ~ U7/8, PIPE (PT,PS,PF) 1/8 ~ 3/8	2	95	50	10	15	0.8
2250 40010062	BT40 -TP1 -1 -62	M3 ~ M12,U1/4 ~ U7/16, PIPE (PT,PS,PF) 1/8	1	62	32	6	18	1.1
2250 40020093	BT40 -TP1 -2 -93	M8 ~ M22,U3/8 ~ U7/8, PIPE (PT,PS,PF) 1/8 ~ 3/8	2	93.5	50	15	20	1.5
2250 40030164	BT40 -TP1 -3 -164	M16 ~ M38,U3/4 ~ 1-3/8, PIPE (PT,PS,PF) 3/8 ~ 1-1/8	3	164	72	20	20	2.6
2250 50010071	BT50 -TP1 -1 -71	M3 ~ M12,U1/4 ~ U7/16, PIPE (PT,PS,PF) 1/8	1	71	32	6	18	3.7
2250 50020102	BT50 -TP1 -2 -102	M8 ~ M22,U3/8 ~ U7/8, PIPE (PT,PS,PF) 1/8 ~ 3/8	2	104.5	50	15	20	4.0
2250 50030142	BT50 -TP1 -3 -142	M16 ~ M38,U3/4 ~ 1-3/8, PIPE (PT,PS,PF) 3/8 ~ 1-1/8	3	142	72	20	20	5.0
2250 50040165	BT50 -TP1 -4 -165	M22 ~ M48,U7/8 ~ 1-3/4, PIPE (PT,PS,PF) 3/4 ~ 1-1/2	4	165	95	22.5	22.5	6.1

1. Para prevenir que el machuelo se rompa, use el adaptador de machuelo con un dispositivo seguro de torque.
2. El adaptador de machuelo se vende por separado

1. To prevent tap breakage, use tap adapter with safety torque device.
2. Tap adapter is sold separately.

Adaptador de machuelo Tap adapter

Pág. 480



Ejemplo para Ordenar - Ordering Example

BT50 - TP1-2 - 102

Interfaz y
diámetro
de husillo

Shank size

Medida de
adaptador

Adapter size

Longitud de
proyección

Projection length(L)

TP3B

Quick Change Tapping Chuck (Auto Depth Control)

- El mecanismo de control de profundidad automático estabiliza la profundidad del machueado.
- Auto depth control mechanism stabilizes tapping depth.

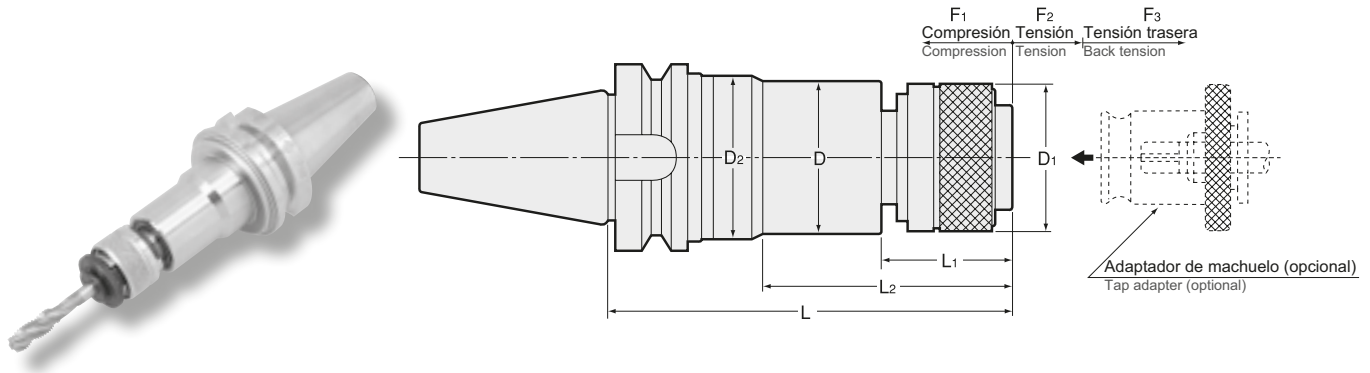

! Para consultar la medida en pulgadas del machuelo, diríjase a la pág. 486.
For Inch size tap, please refer to P.486.

Medidas Métricas - Metric Sizes

Unidad : Métrico
Unit : Metric

Código Code	Modelo Model	Medida de machuelo Tap Size	Medida de adaptador Adapter size	L	L1	L2	D	D1	D2	Compensación axial - Axial compensation			kg
										F1	F2	F3	
3000 10001113	BT30 -TP3B-1 -113	M3 ~ M12 (M15), U1/4 ~ U7/16 (U9/16), Pipe(PT,PS,PF)1/8 ~ 1/4	1	113	30	61.5	34	32	39	0.5	4	8	0.8
3000 30001113	BT40 -TP3B-1 -113	M3 ~ M12 (M15), U1/4 ~ U7/16 (U9/16), Pipe(PT,PS,PF)1/8 ~ 1/4	1	113	30	61.5	34	32	39	0.5	4	8	1.4
3000 30002135	BT40 -TP3B-2 -135	M8 ~ M22, U3/8 ~ U7/8, Pipe(PT,PS,PF)1/8 ~ 1/2	2	135	44.5	86.5	52	50	56	0.5	5	11	2.1
3000 50001128	BT50 -TP3B-1 -128	M3 ~ M12 (M15), U1/4 ~ U7/16 (U9/16), Pipe(PT,PS,PF)1/8 ~ 1/4	1	128	30	61.5	34	32	39	0.5	4	8	4.1
3000 50002150	BT50 -TP3B-2 -150	M8 ~ M22, U3/8 ~ U7/8, Pipe(PT,PS,PF)1/8 ~ 1/2	2	150	44.5	86.5	52	50	56	0.5	5	11	4.7
3000 50003181	BT50 -TP3B-3 -181	M16 ~ M38, U5/8 ~ U1,3/8, Pipe(PT,PS,PF),1/4 ~ 1 1/8	3	181	65.5	119	76	72	80	0.5	6	12	6.4

- 1.Las medidas del machuelo entre corchetes son sólo para machueados ligeros.
- 2.No se puede usar el adaptador de machuelo con portaherramienta con seguro de torque.
- 3.El adaptador de machuelo se vende por separado.

- 1.Tap sizes in brackets are for light tapping only.
- 2.Tap adapter with safety torque clutch cannot be used.
- 3.Tap adapter is sold separately.

Adaptador de machuelo
Tap adapter

Pág. 480



Ejemplo para Ordenar - Ordering Example

BT40 - TP3B-1 - 113

Interfaz y
diámetro de husillo
Shank size

Medida del
adaptador
Adapter size

Longitud de
proyección
Projection length(L)

Cómo usar

How to use

En caso de que se use el control de profundidad automático (orificios ciegos, tornillos cónicos, etcétera):
 In case auto depth control is used (Blind holes, tapered screws etc.)

- | | |
|---|--|
| (1) Suministro rápido desde el punto de aproximación | (1) Rapid feed from approach point |
| (2) Machueado por inclinación | (2) Tapping by pitch |
| (3) Detener la alimentación | (3) Stop feed |
| (4) Rotación del husillo es mayor que el autosuministro de machuelo (Permanencia) | (4) Spindle rotation more than tap self-feed (Dwell) |
| (5) Detención del husillo y reversa | (5) Stop spindle and reverse |
| (6) Suministro de retorno | (6) Back feed |

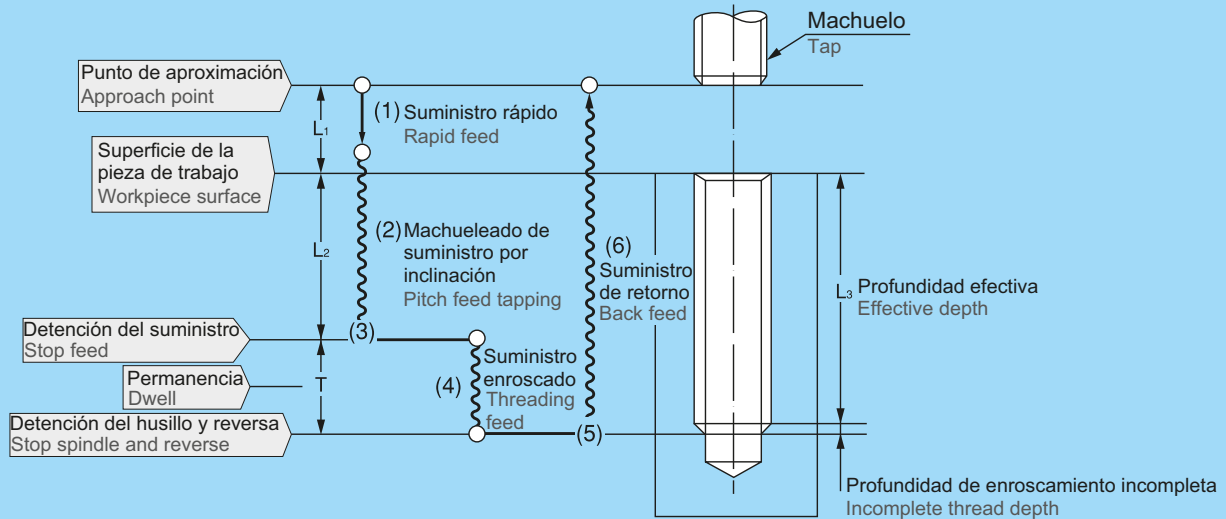

Aproximación L1 = 13 mm o más

Approach L1 = 13mm or more

Profundidad de corte L2 =

Cutting depth L2 =

Profundidad de enroscamiento efectiva L3 + longitud de enroscamiento incompleta - Tensión F2

Effective thread depth L3 + Incomplete thread length - Tension F2

$$\text{Tiempo de permanencia (seg.)} = \frac{\text{Tensión F2}}{\text{Inclinación del machuelo} \times \text{rotación (mín}^{-1})} \times 60$$

$$\text{Dwell time (sec.)} = \frac{\text{Tension F2}}{\text{Tap pitch} \times \text{Rotation (min}^{-1})} \times 60$$

En caso de que no se use el control de profundidad automático (a través del orificio), use el TP3B como un portaherramienta machueado convencional. / In case auto depth control is not used (through hole), use TP3B as a conventional tapping chuck.

- | | |
|--|------------------------------------|
| (1) Suministro rápido desde el punto de aproximación | (1) Rapid feed from approach point |
| (2) Machueado por inclinación | (2) Tapping by pitch |
| (3) Detención del husillo y reversa | (3) Stop spindle and reverse |
| (4) Suministro de retorno | (4) Back feed |
| (5) Retorno rápido | (5) Quick return |

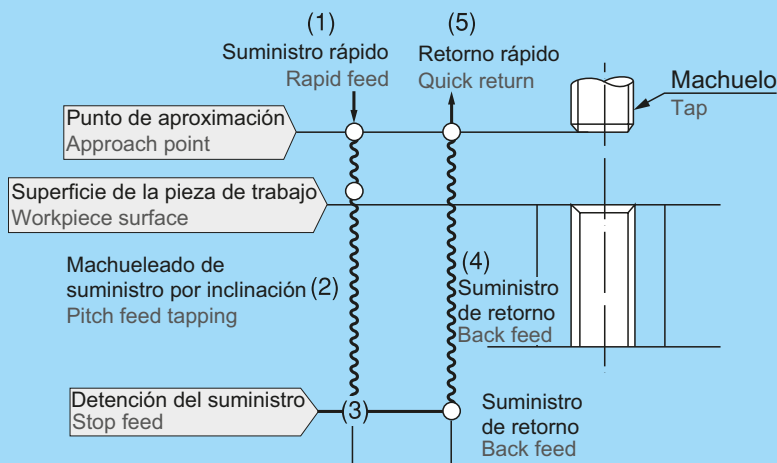

- BT
- CAT
- AHO
- HSK-A/E/F/C
- HSK-T
- C
- UTS
- Máquinas Especializadas / Specialized Machine
- Equipo Relacionado / Related Equipment
- Taladro de Biselado & Casquillo / Bush & Chamfering Drill
- Milling Chuck
- Collet Holder
- "R" Zero Holder
- Hydraulic Chuck
- Shrink Fit
- Tapping Chuck
- Arbors
- Function Holder
- Turning Tool
- Retention Stud
- Tool Shank Dimensions

SLH

Side Lock Holder

Tipo1
Type1

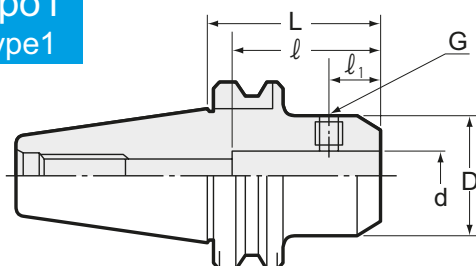

Tipo2
Type2

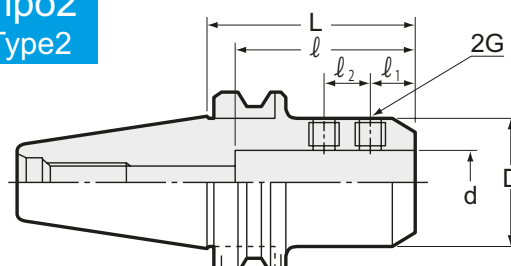

Medida en Pulgadas - Inch Sizes

Unidad : Pulgadas
Unit : Inch

Código Code	Modelo Model	Tipo Type	d (H6)	D	L	ℓ	ℓ ₁	ℓ ₂	G	kg
0740 03108060	BT30 -SLH -0250 -60	1	0.250	0.790	2.362	3.000	0.437	—	1/4-28 × 1/4	
0740 03108105	-105	1	0.250	0.790	4.134	3.000	0.437	—	1/4-28 × 1/4	0.6
0740 03110060	BT30 -SLH -0313 -60	1	0.3125	0.870	2.362	3.000	0.437	—	5/16-24 × 1/4	
0740 03110105	-105	1	0.3125	0.870	4.134	3.000	0.437	—	5/16-24 × 1/4	
0740 03112060	BT30 -SLH -0375 -60	1	0.375	1.000	2.362	3.000	0.710	—	3/8-24 × 5/16	
0740 03112105	-105	1	0.375	1.000	4.134	3.000	0.710	—	3/8-24 × 5/16	
0740 03114060	BT30 -SLH -0438 -60	1	0.4375	1.380	2.362	3.000	0.710	—	7/16-20 × 3/8	
0740 03114105	-105	1	0.4375	1.380	4.134	3.000	0.710	—	7/16-20 × 3/8	
0740 03116060	BT30 -SLH -0500 -60	1	0.500	1.380	2.362	3.000	0.710	—	7/16-20 × 3/8	
0740 03116105	-105	1	0.500	1.380	4.134	3.000	0.710	—	7/16-20 × 3/8	
0740 03120060	BT30 -SLH -0625 -60	1	0.625	1.650	2.362	3.150	0.700	—	9/16-18 × 1/2	
0740 03120105	-105	1	0.625	1.650	4.134	3.150	0.700	—	9/16-18 × 1/2	
0740 03124090	BT30 -SLH -0750 -90	1	0.750	1.750	3.543	3.976	0.740	—	5/8-18 × 1/2	
0740 03124120	-120	1	0.750	1.750	4.724	3.976	0.740	—	5/8-18 × 1/2	
0740 03128090	BT30 -SLH -0875 -90	1	0.875	2.000	3.543	3.453	0.740	—	5/8-18 × 1/2	
0740 03128120	-120	1	0.875	2.000	4.724	4.331	0.740	—	5/8-18 × 1/2	
0740 03308075	BT40 -SLH -0250 -75	1	0.250	0.790	2.953	3.000	0.437	—	1/4-28 × 1/4	
0740 03308105	-105	1	0.250	0.790	4.134	3.000	0.437	—	1/4-28 × 1/4	
0740 03310075	BT40 -SLH -0313 -75	1	0.3125	0.870	2.953	3.000	0.437	—	5/16-24 × 1/4	
0740 03310105	-105	1	0.3125	0.870	4.134	3.000	0.437	—	5/16-24 × 1/4	
0740 03312075	BT40 -SLH -0375 -75	1	0.375	1.000	2.953	3.000	0.710	—	3/8-24 × 5/16	1.1
0740 03312105	-105	1	0.375	1.000	4.134	3.000	0.710	—	3/8-24 × 5/16	
0740 03314075	BT40 -SLH -0438 -75	1	0.4375	1.380	2.953	3.000	0.710	—	7/16-20 × 3/8	
0740 03314105	-105	1	0.4375	1.380	4.134	3.000	0.710	—	7/16-20 × 3/8	
0740 03316075	BT40 -SLH -0500 -75	1	0.500	1.380	2.953	3.000	0.710	—	7/16-20 × 3/8	1.3
0740 03316105	-105	1	0.500	1.380	4.134	3.000	0.710	—	7/16-20 × 3/8	
0740 03320075	BT40 -SLH -0625 -75	1	0.625	1.650	2.953	3.150	0.700	—	9/16-18 × 1/2	
0740 03320105	-105	1	0.625	1.650	4.134	3.150	0.700	—	9/16-18 × 1/2	
0740 03324075	BT40 -SLH -0750 -75	1	0.750	1.750	2.953	3.976	0.740	—	5/8-18 × 1/2	1.3
0740 03324105	-105	1	0.750	1.750	4.134	3.976	0.740	—	5/8-18 × 1/2	
0740 03328090	BT40 -SLH -0875 -90	1	0.875	2.000	3.543	4.331	0.740	—	5/8-18 × 1/2	
0740 03328135	-135	1	0.875	2.000	5.315	4.331	0.740	—	5/8-18 × 1/2	
0740 03332090	BT40 -SLH -1000 -90	1	1.000	2.360	3.543	3.543	0.860	—	3/4-16 × 11/16	
0740 03332135	-135	1	1.000	2.360	5.315	4.843	0.860	—	3/4-16 × 11/16	
0740 03340090	BT40 -SLH -1250 -90	1	1.250	2.650	3.543	3.543	0.860	—	3/4-16 × 11/16	
0740 03340135	-135	1	1.250	2.650	5.315	4.843	0.860	—	3/4-16 × 11/16	
0740 03348105	BT40 -SLH -1500 -105	1	1.500	2.990	4.134	3.543	1.181	—	3/4-16 × 11/16	
0740 03348150	-150	1	1.500	2.990	5.906	4.843	1.181	—	3/4-16 × 11/16	

Medida en Pulgadas - Inch Sizes

Unidad : Pulgadas
Unit : Inch

Código Code	Modelo Model	Tipo Type	d (H6)	D	L	ℓ	ℓ ₁	ℓ ₂	G	kg
0740 03508090	BT50 -SLH -0250 -90	1	0.250	0.790	3.543	3.000	0.437	—	1/4-28 × 1/4	
0740 03508135		1	0.250	0.790	5.315	3.000	0.437	—	1/4-28 × 1/4	
0740 03510090	BT50 -SLH -0313 -90	1	0.3125	0.870	3.543	3.000	0.437	—	5/16-24 × 1/4	
0740 03510135		1	0.3125	0.870	5.315	3.000	0.437	—	5/16-24 × 1/4	
0740 03512090	BT50 -SLH -0375 -90	1	0.375	1.000	3.543	3.000	0.710	—	3/8-24 × 5/16	
0740 03512135		1	0.375	1.000	5.315	3.000	0.710	—	3/8-24 × 5/16	
0740 03514090	BT50 -SLH -0438 -90	1	0.4375	1.380	3.543	3.000	0.710	—	7/16-20 × 3/8	
0740 03514135		1	0.4375	1.380	5.315	3.000	0.710	—	7/16-20 × 3/8	
0740 03516090	BT50 -SLH -0500 -90	1	0.500	1.380	3.543	3.000	0.710	—	7/16-20 × 3/8	
0740 03516135		1	0.500	1.380	5.315	3.000	0.710	—	7/16-20 × 3/8	
0740 03520090	BT50 -SLH -0625 -90	1	0.625	1.650	3.543	3.150	0.700	—	9/16-18 × 1/2	
0740 03520135		1	0.625	1.650	5.315	3.150	0.700	—	9/16-18 × 1/2	
0740 03524090	BT50 -SLH -0750 -90	1	0.750	1.750	3.543	3.976	0.740	—	5/8-18 × 1/2	
0740 03524135		1	0.750	1.750	5.315	3.976	0.740	—	5/8-18 × 1/2	4.5
0740 03528090	BT50 -SLH -0875 -90	1	0.875	2.000	3.543	4.331	0.740	—	5/8-18 × 1/2	
0740 03528135		1	0.875	2.000	5.315	4.331	0.740	—	5/8-18 × 1/2	
0740 03532105	BT50 -SLH -1000 -105	1	1.000	2.360	4.134	4.843	0.860	—	3/4-16 × 11/16	
0740 03532150		1	1.000	2.360	5.906	4.843	0.860	—	3/4-16 × 11/16	
0740 03540105	BT50 -SLH -1250 -105	1	1.250	2.650	4.134	4.843	0.860	—	3/4-16 × 11/16	
0740 03540150		1	1.250	2.650	5.906	4.843	0.860	—	3/4-16 × 11/16	5.8
0740 03548105	BT50 -SLH -1500 -105	1	1.500	2.990	4.134	4.843	1.181	—	3/4-16 × 11/16	
0740 03548150		1	1.500	2.990	5.906	4.843	1.181	—	3/4-16 × 11/16	
0740 03564135	BT50 -SLH -2000 -135	2	2.000	3.740	5.315	4.843	1.260	1.500	1-12 × 7/8	
0740 03564165		2	2.000	3.740	6.496	4.843	1.260	1.500	1-12 × 7/8	

Ejemplo para Ordenar - Ordering Example

BT30 - SLH - 0250 - 60Interfaz y diámetro
de husilloDiámetro
InternoLongitud de
proyección

Shank size

I.D. (d)

Projection
length (L)

SL2

Side Lock Holder

- Para zanco recto JIS con terminado plano.
- For JIS straight shank endmill with flat.

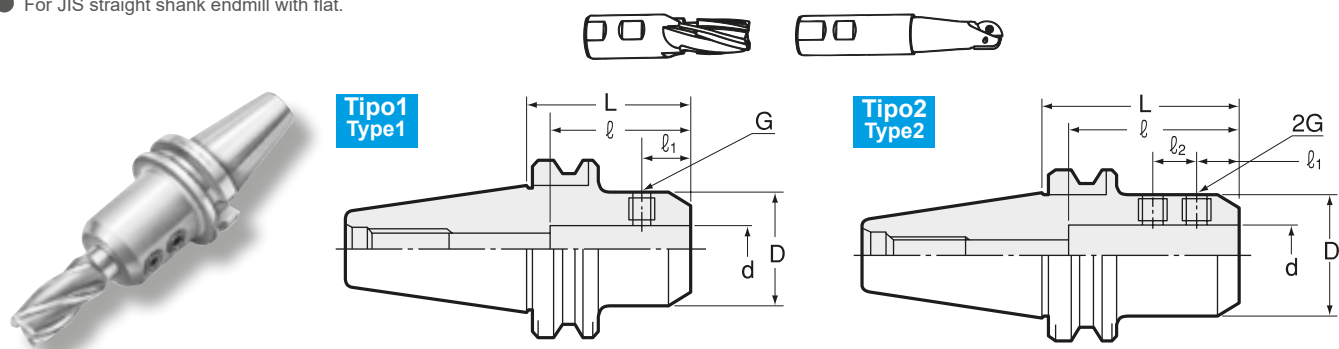

Medidas Métricas - Metric Sizes

Unidad : Métrico
Unit : Metric

Código Code	Modelo Model	Tipo Type	d (H6)	D	L	ℓ1	ℓ2	ℓ	G	kg
0740 02106060	BT30 -SL2 -6 -60	1	6	25	60	18	—	36	M6	0.5
0740 02108060	-8 -60	1	8	28	60	18	—	36	M8	0.8
0740 02110060	-10 -60	1	10	35	60	20	—	40	M10	0.7
0740 02112060	-12 -60	1	12	42	60	22.5	—	45	M12	0.8
0740 02116090	-16 -90	1	16	48	90	24	—	48	M14	1.2
0740 02120090	-20 -90	1	20	52	90	25	—	50	M16	1.3
0740 02306075	BT40 -SL2 -6 -75	1	6	25	75	18	—	36	M6	1.2
0740 02308075	-8 -75	1	8	28	75	18	—	36	M8	1.2
0740 02310075	-10 -75	1	10	35	75	20	—	40	M10	1.2
0740 02312075	-12 -75	1	12	42	75	22.5	—	45	M12	1.4
0740 02316075	-16 -75	1	16	48	75	24	—	48	M14	1.5
0740 02320075	-20 -75	1	20	52	75	25	—	50	M16	1.6
0740 02325090	-25 -90	2	25	65	90	24	25	56	M18	2.3
0740 02332120	-32 -120	2	32	72	120	24	28	60	M20	3.3
0740 02506090	BT50 -SL2 -6 -90	1	6	25	90	18	—	36	M6	3.7
0740 02508090	-8 -90	1	8	28	90	18	—	36	M8	3.7
0740 02510090	-10 -90	1	10	35	90	20	—	40	M10	3.8
0740 02512090	-12 -90	1	12	42	90	22.5	—	45	M12	4.0
0740 02516090	-16 -90	1	16	48	90	24	—	48	M14	4.1
0740 02520090	-20 -90	1	20	52	90	25	—	50	M16	4.2
0740 02525105	-25 -105	2	25	65	105	24	25	56	M18	4.9
0740 02532120	-32 -120	2	32	72	120	24	28	60	M20	5.6
0740 02540120	-40 -120	2	40	80	120	30	32	70	M20	5.9
0740 02542120	-42 -120	2	42	82	120	30	32	70	M20	6.0

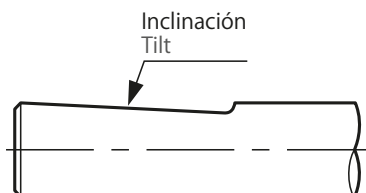

Favor de contactar a NT si la herramienta de corte se ha inclinado hasta quedar plana sobre el zanco.
El portaherramienta de la herramienta especial que va con esa inclinación puede fabricarse.
Please contact NT if the cutting tool has tilted flat on the shank.
Special tool holder that matches to the tilted flat can be manufactured.

Ejemplo para Ordenar - Ordering Example

BT30	- SL2	- 6	- 60
Interfaz y diámetro de husillo Shank size		Diámetro Interno I.D. (d)	Longitud de proyección Projection length (L)

Pulgada a métrico → Pulgada × 25.4
Métrico a pulgada → Métrico ÷ 25.4 ó métrico por 0.03937



Tamaños especiales / personalizados bajo pedido

Side Lock Holder

- Para zanco recto con barra mandriladora y con zanco recto y cabeza plana de la barra de la cabeza de la barra.
- For straight shank boring bar with flat and straight shank boring head with flat.

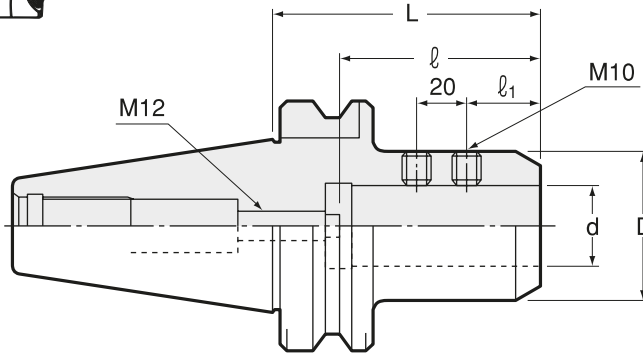

Medidas Métricas - Metric Sizes

Unidad : Métrico
Unit : Metric

Código Code	Modelo Model	d (H6)	L	D	ℓ MIN	ℓ MAX	ℓ1	kg
0740 00116075	BT30 -SLA16 -75	16	75	40	55	70	25	0.8
0740 00120075	BT30 -SLA20 -75	20	75	40	55	70	25	0.8
0740 00125075	BT30 -SLA25 -75	25	75	46	55	70	25	0.8
0740 00320090	BT40 -SLA20 -90	20	90	50	55	70	25	1.8
0740 00325090	BT40 -SLA25 -90	25	90	50	55	70	25	1.7
0740 00332090	BT40 -SLA32 -90	32	90	60	65	80	30	1.9
0740 00342090	BT40 -SLA42 -90	42	90	63	65	80	30	1.6
0740 00520105	BT50 -SLA20 -105	20	105	50	55	70	25	4.4
0740 00525105	BT50 -SLA25 -105	25	105	50	55	70	25	4.3
0740 00532105	BT50 -SLA32 -105	32	105	60	65	80	30	4.5
0740 00542105	BT50 -SLA42 -105	42	105	70	65	80	30	4.7

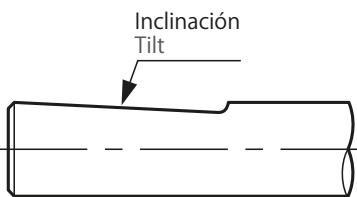

Favor de contactar a NT si la herramienta de corte se ha inclinado hasta quedar plana sobre el zanco.
El portaherramienta de la herramienta especial que va con esa inclinación puede fabricarse.
Please contact NT if the cutting tool has tilted flat on the shank.
Special tool holder that matches to the tilted flat can be manufactured.

Ejemplo para Ordenar - Ordering Example

BT30 - SLA 16 - 75

Interfaz y
diámetro de husilloDiámetro
InternoLongitud de
proyección

Shank size

I.D. (d)

Projection
length (L)

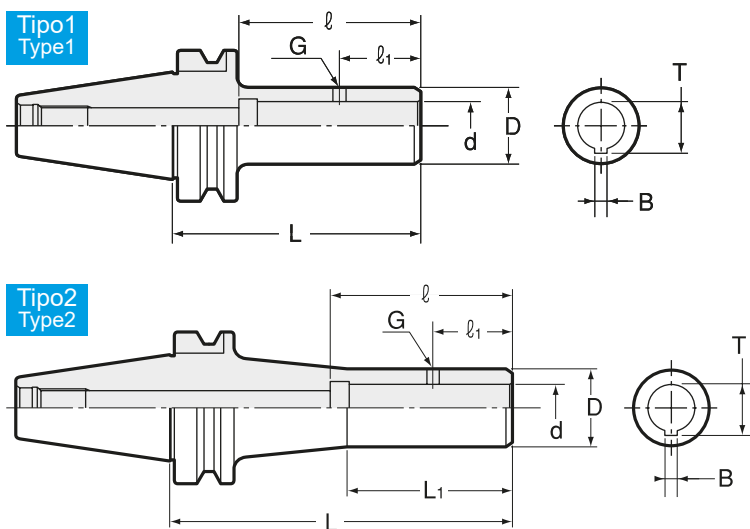

Medidas Métricas - Metric Sizes

Unidad : Métrico
Unit : Metric

Código Code	Modelo Model	Tipo Type	d (H6)	L	l ₁	l	D	G	L ₁	B	T	kg
0740 01116075	BT30 -SLB16 -75	1	16	75	34	74	35	M8	—	5	17.3	0.5
0740 01116105	-105	1	16	105	34	74	35	M8	—	5	17.3	0.7
0740 01120075	BT30 -SLB20 -75	1	20	75	34	77	40	M8	—	5	21.3	0.7
0740 01120105	-105	1	20	105	34	77	40	M8	—	5	21.3	1.0
0740 01320105	BT40 -SLB20 -105	1	20	105	34	77	32	M6	—	5	21.3	1.5
0740 01320145	-145	2	20	145	34	77	32	M6	70	5	21.3	1.5
0740 01326105	BT40 -SLB26 -105	1	26	105	40	85	50	M10	—	5	28.2	1.8
0740 01328135	BT40 -SLB28 -135	1	28	135	38	85	40	M8	—	6	29.7	1.5
0740 01328175	-175	2	28	175	38	85	40	M8	78	6	29.7	2.1
0740 01335135	BT40 -SLB35 -135	1	35	135	55	106	60	M10	—	6	37.6	2.2
0740 01335136	BT40 -SLB35T -135	1	35	135	55	106	60	M10	—	7	38.2	2.2
0740 01336135	BT40 -SLB36 -135	1	36	135	45	106	50	M8	—	8	37.7	2.3
0740 01520135	BT50 -SLB20 -135	1	20	135	34	77	32	M6	—	5	21.3	4.5
0740 01520175	-175	2	20	175	34	77	32	M6	70	5	21.3	4.7
0740 01526105	BT50 -SLB26 -105	1	26	105	40	85	50	M10	—	5	28.2	4.4
0740 01528135	BT50 -SLB28 -135	1	28	135	38	85	40	M8	—	6	29.7	4.0
0740 01528175	-175	2	28	175	38	85	40	M8	78	6	29.7	4.6
0740 01535135	BT50 -SLB35 -135	1	35	135	55	106	60	M10	—	6	37.6	4.7
0740 01535136	BT50 -SLB35T -135	1	35	135	55	106	60	M10	—	7	38.2	4.7
0740 01536165	BT50 -SLB36 -165	1	36	165	45	106	50	M8	—	8	37.7	4.5
0740 01536205	-205	2	36	205	45	106	50	M8	98	8	37.7	5.2
0740 01548165	BT50 -SLB48 -165	1	48	165	65	129	80	M10	—	8	51.0	6.5

Sub-portaherramientas SLB - SLB Sub Holders

Portaherramienta con zanco recto
Straight drill chuck

Pág. 505



Adaptador ajustable
Adjustable adapter

Pág. 490

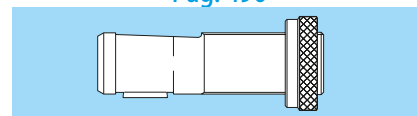

Ejemplo para Ordenar - Ordering Example

BT30 - SLB 16 - 75

Interfaz y
diámetro de husillo

Shank size

Diámetro
Interno
I.D. (d)

Longitud de
proyección
Projection
length (L)

Side Lock Holder

- Para uso con herramientas de corte de zanco recto con una cara plana en su circunferencia.
- For use with straight shank cutting tools with a flat and a flange.

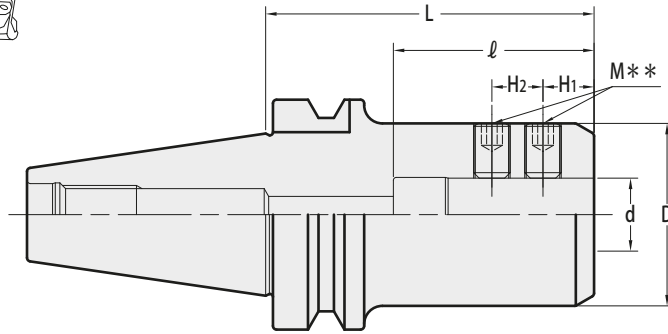
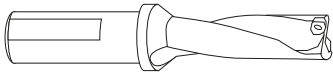

Código Code	Modelo Model	d	L	l	D	H1	H2	M	—
0740 04120075	BT30 -SLD20 -75	20	75	55	50	14	14	10	20,000
0740 04125080	-SLD25 -80	25	80	55	55	15	20	14	23,000
0740 04132085	-SLD32 -85	32	85	63	62	15	20	16	25,000
0740 04320090	BT40 -SLD20 -90	20	90	55	50	14	14	10	22,000
0740 04320105	-105	20	105	55	50	14	14	10	23,000
0740 04325090	-SLD25 -90	25	90	60	55	15	20	14	23,000
0740 04325105	-105	25	105	60	55	15	20	14	24,000
0740 04332090	-SLD32 -90	32	90	65	62	15	20	16	23,000
0740 04332105	-105	32	105	65	62	15	20	16	24,000
0740 04332135	-135	32	135	65	62	15	20	16	26,000
0740 04340090	-SLD40 -90	40	90	75	70	15	25	16	30,000
0740 04520090	BT50 -SLD20 -90	20	90	55	50	14	14	10	30,000
0740 04520135	-135	20	135	55	50	14	14	10	32,500
0740 04520165	-165	20	165	55	50	14	14	10	34,000
0740 04520200	-200	20	200	55	50	14	14	10	53,000
0740 04520250	-250	20	250	55	50	14	14	10	58,000
0740 04525105	-SLD25 -105	25	105	60	55	15	20	14	32,000
0740 04525135	-135	25	135	60	55	15	20	14	33,500
0740 04525165	-165	25	165	60	55	15	20	14	35,000
0740 04525200	-200	25	200	60	55	15	20	14	53,500
0740 04525250	-250	25	250	60	55	15	20	14	58,500
0740 04532105	-SLD32 -105	32	105	65	62	15	20	16	32,000
0740 04532135	-135	32	135	65	62	15	20	16	33,500
0740 04532165	-165	32	165	65	62	15	20	16	35,000
0740 04532200	-200	32	200	65	62	15	20	16	53,500
0740 04532250	-250	32	250	65	62	15	20	16	58,500
0740 04540105	-SLD40 -105	40	105	75	70	15	25	16	34,000
0740 04540135	-135	40	135	75	70	15	25	16	35,500
0740 04540165	-165	40	165	75	70	15	25	16	37,000
0740 04540200	-200	40	200	75	70	15	25	16	55,000
0740 04540250	-250	40	250	75	70	15	25	16	60,000
0740 04550105	-SLD50 -105	50	105	85	80	15	25	16	42,000
0740 04550150	-150	50	150	85	80	15	25	16	46,500

Ejemplo para Ordenar - Ordering Example

BT30 - SLD20 - 75

Interfaz y diámetro de husillo
Shank size

Diámetro Interno D1
I.D.

Longitud de proyección
Projection length (L)

FMH•A

Face Mill Arbor (For Cutters with Oil Hole)

- El refrigerante fluye del refrentado de la locación central al cortador con vena de lubricación.
- Coolant flows from the end face of centering location to cutter with oil hole.

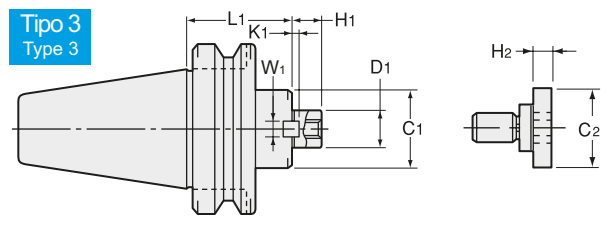
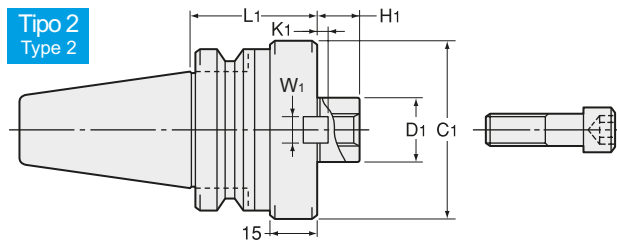
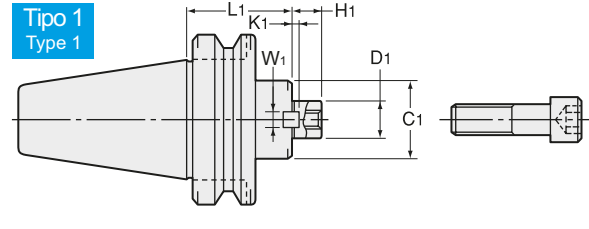
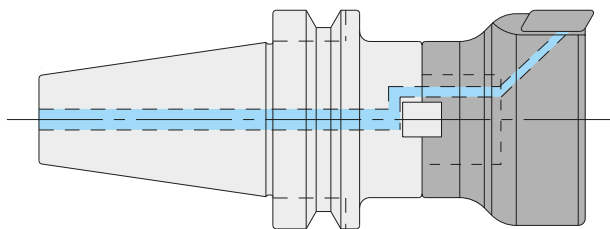

Medidas Métricas - Metric Sizes

Unidad : Métrico
Unit : Metric

Código Code	Modelo Model	Tipo Type	D1 (h6)	L1	C1	H1	W1	K1	C2	H2	—	Perno de sujeción Clamp bolt
0770 16116045	BT30 -FMH16A -34 -45	1	16	45	34	17	8	5	—	—	19,120	M8
0770 16116060	-60	1	16	60	34	17	8	5	—	—	19,120	
0770 16122045	-FMH22A -47 -45	2	22	45	47	18	10	5	—	—	19,550	M10
0770 16122060	-60	2	22	60	47	18	10	5	—	—	19,550	
0770 16123045	-FMH22.225A -47 -45	2	22.225	45	47	17	8	3.5	—	—	19,850	M10
0770 16123060	-60	2	22.225	60	47	17	8	3.5	—	—	19,850	
0770 16125060	-FMH25.4A -60 -60	2	25.4	60	60	22	9.5	5	—	—	20,150	M12
0770 16127060	-60	2	27	60	60	20	12	6	—	—	22,500	
0770 16316045	BT40 -FMH16A -34 -45	1	16	45	34	17	8	5	—	—	19,910	M8
0770 16316060	-60	1	16	60	34	17	8	5	—	—	19,910	
0770 16316075	-75	1	16	75	34	17	8	5	—	—	20,350	
0770 16316090	-90	1	16	90	34	17	8	5	—	—	20,350	
0770 16322045	-FMH22A -47 -45	1	22	45	47	18	10	5	—	—	23,210	M10
0770 16322060	-60	1	22	60	47	18	10	5	—	—	23,650	
0770 16322075	-75	1	22	75	47	18	10	5	—	—	23,870	
0770 16322090	-90	1	22	90	47	18	10	5	—	—	24,310	
0770 17322045	-60 -45	1	22	45	60	18	10	5	—	—	23,210	
0770 17322060	-60	1	22	60	60	18	10	5	—	—	23,650	
0770 17322075	-75	1	22	75	60	18	10	5	—	—	23,870	
0770 17322090	-90	1	22	90	60	18	10	5	—	—	24,310	
0770 16323045	-FMH22.225A -47 -45	1	22.225	45	47	17	8	3.5	—	—	23,210	
0770 16323060	-60	1	22.225	60	47	17	8	3.5	—	—	23,650	
0770 16323075	-75	1	22.225	75	47	17	8	3.5	—	—	23,870	
0770 16323090	-90	1	22.225	90	47	17	8	3.5	—	—	24,310	
0770 17323045	-60 -45	1	22.225	45	60	17	8	3.5	—	—	23,210	
0770 17323060	-60	1	22.225	60	60	17	8	3.5	—	—	23,650	
0770 17323075	-75	1	22.225	75	60	17	8	3.5	—	—	23,870	
0770 17323090	-90	1	22.225	90	60	17	8	3.5	—	—	24,310	
0770 16325060	-FMH25.4A -60 -60	1	25.4	60	60	22	9.5	5	—	—	23,650	M12
0770 16325075	-75	1	25.4	75	60	22	9.5	5	—	—	23,870	
0770 16325090	-90	1	25.4	90	60	22	9.5	5	—	—	24,310	
0770 16327060	-FMH27A -60 -60	1	27	60	60	20	12	6	—	—	23,650	
0770 16327075	-75	1	27	75	60	20	12	6	—	—	23,870	
0770 16327090	-90	1	27	90	60	20	12	6	—	—	24,310	
0770 17327060	-76 -60	2	27	60	76	20	12	6	—	—	23,650	
0770 17327075	-75	2	27	75	76	20	12	6	—	—	23,870	
0770 17327090	-90	2	27	90	76	20	12	6	—	—	24,310	
0770 16331060	-FMH31.75A -76 -60	2	31.75	60	76	30	12.7	7	—	—	23,870	M16
0770 16331075	-75	2	31.75	75	76	30	12.7	7	—	—	24,310	
0770 16331090	-90	2	31.75	90	76	30	12.7	7	—	—	24,640	
0770 17331060	-96 -60	2	31.75	60	96	30	12.7	7	—	—	34,120	
0770 17331075	-75	2	31.75	75	96	30	12.7	7	—	—	34,850	
0770 17331090	-90	2	31.75	90	96	30	12.7	7	—	—	35,600	
0770 16332060	-FMH32A -96 -60	2	32	60	96	22	14	7	—	—	34,120	
0770 16332075	-75	2	32	75	96	22	14	7	—	—	34,850	
0770 16332090	-90	2	32	90	96	22	14	7	—	—	35,600	

Medidas Métricas - Metric Sizes

Unidad : Métrico
Unit : Metric

Código Code	Modelo Model	Tipo Type	D1 (h6)	L1	C1	H1	W1	K1	C2	H2	—	Perno de sujeción Clamp Bolt
0770 16516045	BT50 -FMH16A	-34 -45	1	16	45	34	17	8	5	—	—	33,470
0770 16516090		-90	1	16	90	34	17	8	5	—	—	33,810
0770 16516150		-150	1	16	150	34	17	8	5	—	—	34,270
0770 16516200		-200	1	16	200	34	17	8	5	—	—	35,650
0770 16516250		-250	1	16	250	34	17	8	5	—	—	65,550
0770 16516300		-300	1	16	300	34	17	8	5	—	—	78,360
0770 16522045	-FMH22A	-47 -45	1	22	45	47	18	10	5	—	—	33,470
0770 16522090		-90	1	22	90	47	18	10	5	—	—	36,230
0770 16522150		-150	1	22	150	47	18	10	5	—	—	38,760
0770 16522200		-200	1	22	200	47	18	10	5	—	—	39,100
0770 16522250		-250	1	22	250	47	18	10	5	—	—	65,550
0770 16522300		-300	1	22	300	47	18	10	5	—	—	78,360
0770 17522045		-60 -45	1	22	45	60	18	10	5	—	—	33,470
0770 17522090		-90	1	22	90	60	18	10	5	—	—	36,230
0770 17522150		-150	1	22	150	60	18	10	5	—	—	38,760
0770 17522200		-200	1	22	200	60	18	10	5	—	—	39,100
0770 17522250		-250	1	22	250	60	18	10	5	—	—	65,550
0770 17522300		-300	1	22	300	60	18	10	5	—	—	78,360
0770 16523045	-FMH22.225A	-47 -45	1	22.225	45	47	17	8	3.5	—	—	33,470
0770 16523090		-90	1	22.225	90	47	17	8	3.5	—	—	36,230
0770 16523150		-150	1	22.225	150	47	17	8	3.5	—	—	38,760
0770 16523200		-200	1	22.225	200	47	17	8	3.5	—	—	39,220
0770 16523250		-250	1	22.225	250	47	17	8	3.5	—	—	65,550
0770 16523300		-300	1	22.225	300	47	17	8	3.5	—	—	78,360
0770 17523045		-60 -45	1	22.225	45	60	17	8	3.5	—	—	33,470
0770 17523090		-90	1	22.225	90	60	17	8	3.5	—	—	36,230
0770 17523150		-150	1	22.225	150	60	17	8	3.5	—	—	38,760
0770 17523200		-200	1	22.225	200	60	17	8	3.5	—	—	39,220
0770 17523250		-250	1	22.225	250	60	17	8	3.5	—	—	65,550
0770 17523300		-300	1	22.225	300	60	17	8	3.5	—	—	78,360
0770 16525045	-FMH25.4A	-60 -45	1	25.4	45	60	22	9.5	5	—	—	33,470
0770 16525090		-90	1	25.4	90	60	22	9.5	5	—	—	36,230
0770 16525150		-150	1	25.4	150	60	22	9.5	5	—	—	38,760
0770 16525200		-200	1	25.4	200	60	22	9.5	5	—	—	39,220
0770 16525250		-250	1	25.4	250	60	22	9.5	5	—	—	65,550
0770 16525300		-300	1	25.4	300	60	22	9.5	5	—	—	78,360
0770 16527045	-FMH27A	-60 -45	1	27	45	60	20	12	6	—	—	33,470
0770 16527090		-90	1	27	90	60	20	12	6	—	—	36,230
0770 16527150		-150	1	27	150	60	20	12	6	—	—	38,760
0770 16527200		-200	1	27	200	60	20	12	6	—	—	39,220
0770 16527250		-250	1	27	250	60	20	12	6	—	—	65,550
0770 16527300		-300	1	27	300	60	20	12	6	—	—	78,360
0770 17527045		-76 -45	1	27	45	76	20	12	6	—	—	33,470
0770 17527090		-90	1	27	90	76	20	12	6	—	—	36,230
0770 17527150		-150	1	27	150	76	20	12	6	—	—	38,760
0770 17527200		-200	1	27	200	76	20	12	6	—	—	39,220
0770 17527250		-250	1	27	250	76	20	12	6	—	—	65,550
0770 17527300		-300	1	27	300	76	20	12	6	—	—	78,360
0770 16531045	-FMH31.75A	-76 -45	1	31.75	45	76	30	12.7	7	—	—	33,470
0770 16531105		-105	1	31.75	105	76	30	12.7	7	—	—	37,950
0770 16531150		-150	1	31.75	150	76	30	12.7	7	—	—	38,760
0770 16531200		-200	1	31.75	200	76	30	12.7	7	—	—	39,220
0770 17531045		-96 -45	1	31.75	45	96	30	12.7	7	—	—	33,470
0770 17531105		-105	1	31.75	105	96	30	12.7	7	—	—	37,950
0770 17531150		-150	1	31.75	150	96	30	12.7	7	—	—	38,760
0770 17531200		-200	1	31.75	200	96	30	12.7	7	—	—	39,220
0770 16532045	-FMH32A	-96 -45	1	32	45	96	22	14	7	—	—	33,470
0770 16532105		-105	1	32	105	96	22	14	7	—	—	37,950
0770 16532150		-150	1	32	150	96	22	14	7	—	—	38,760
0770 16532200		-200	1	32	200	96	22	14	7	—	—	39,220
0770 16538045	-FMH38.1A	-80 -45	3	38.1	45	80	34	15.9	9	50	14	33,470
0770 16538075		-75	3	38.1	75	80	34	15.9	9	50	14	36,230
0770 16538105		-105	3	38.1	105	80	34	15.9	9	50	14	37,950
0770 16538150		-150	3	38.1	150	80	34	15.9	9	50	14	38,760
0770 17538045		-100 -45	3	38.1	45	100	34	15.9	9	50	14	33,470
0770 17538075		-75	3	38.1	75	100	34	15.9	9	50	14	36,230
0770 17538105		-105	3	38.1	105	100	34	15.9	9	50	14	37,950
0770 17538150		-150	3	38.1	150	100	34	15.9	9	50	14	38,760
0770 16540045	-FMH40A	-100 -45	3	40	45	100	26	16	8.5	50	14	33,470
0770 16540075		-75	3	40	75	100	26	16	8.5	50	14	36,230
0770 16540105		-105	3	40	105	100	26	16	8.5	50	14	37,950
0770 16540150		-150	3	40	150	100	26	16	8.5	50	14	38,760
0770 16550045	-FMH50.8A	-100 -45	3	50.8	45	100	36	19.05	10	65	14	33,470
0770 16550075		-75	3	50.8	75	100	36	19.05	10	65	14	36,230
0770 16550105		-105	3	50.8	105	100	36	19.05	10	65	14	37,950
0770 16550150		-150	3	50.8	150	100	36	19.05	10	65	14	38,760

Incluye el perno de sujeción.
Clamp bolt is Included.

Ejemplo para Ordenar - Ordering Example

BT30 - FMH25.4A - 60 - 60

Interfaz y diámetro de husillo Diámetro Interno D1 C1 Longitud de proyección
Shank size D1 C1 Projection length (L)

Pulgada a métrico → Pulgada × 25.4
Métrico a pulgada → Métrico ÷ 25.4 ó métrico por 0.03937



Tamaños especiales / personalizados bajo pedido



Face Mill Arbor

- Para fresa JIS B4113.
- For JIS B4113 face mill.

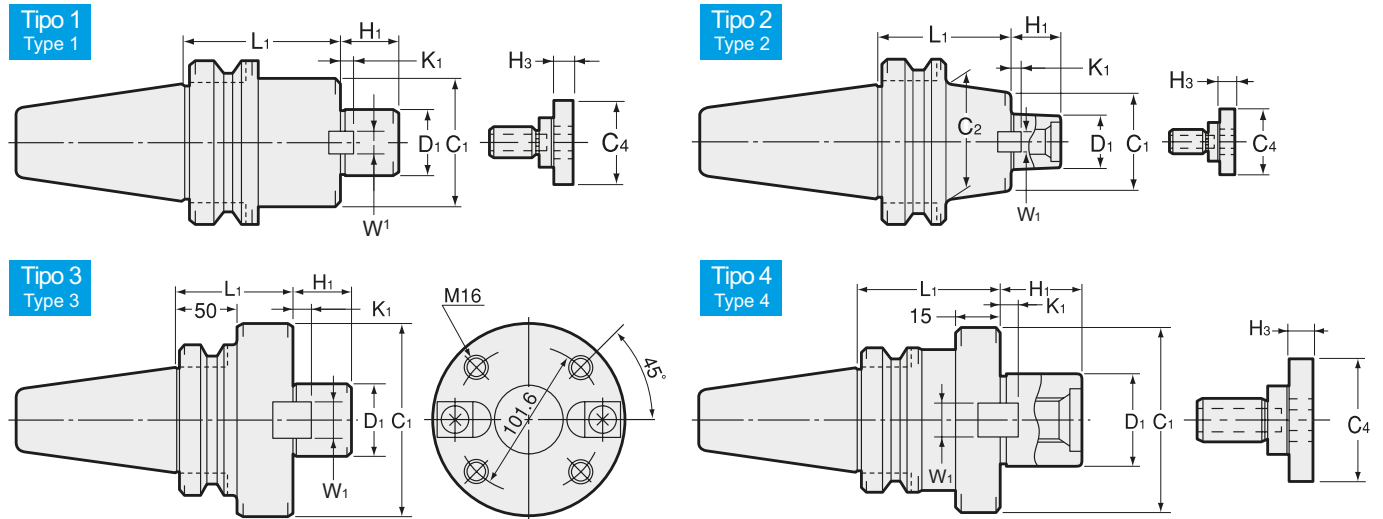

Medidas Métricas - Metric Sizes

Unidad : Métrico
Unit : Metric

Código Code	Modelo Model	Tipo Type	D1 (h6)	L1	C1	C2	H1	W1	K1	C4	H3	kg	—	Perno de sujeción Clamp Bolt	Ejemplo del diá. de cortador Cutter dia. Example	
0770 10119045	BT30 -FMA19.05A	-45	1	19.05	45	—	16	8	3.5	22	9	0.7	12,960	MBA-M10-19.05	—	
0770 10119060		-60	1	19.05	60	—	16	8	3.5	22	9	1.0	12,000			
0770 10119090		-90	1	19.05	90	—	16	8	3.5	22	9	1.3	13,000			
0770 10125045	-FMA25.4A	-45	4	25.4	45	—	22	9.5	5	33	10	0.9	12,960	MBA-M12	80	
0770 10125060		-60	4	25.4	60	—	22	9.5	5	33	10	1.1	12,960			
0770 10125090		-90	4	25.4	90	—	22	9.5	5	33	10	1.5	14,040			
0770 10319045	BT40 -FMA19.05A	-45	1	19.05	45	—	16	8	3.5	22	9	1.1	16,500	MBA-M10-19.05	—	
0770 10319060		-60	1	19.05	60	—	16	8	3.5	22	9	1.3	17,050			
0770 10319090		-90	1	19.05	90	—	16	8	3.5	22	9	1.5	17,600			
0770 10325045	-FMA25.4A	-45	1	25.4	45	—	22	9.5	5	33	10	1.5	16,500	MBA-M12	80	
0770 10325090		-90	1	25.4	90	—	22	9.5	5	33	10	2.1	17,600			
0770 10331045	-FMA31.75A	-45	1	31.75	45	—	30	12.7	7	40	10	1.7	16,500	MBA-M16	100	
0770 10331075		-75	1	31.75	75	—	30	12.7	7	40	10	2.3	17,600			
0770 10338060	-FMA38.1A	-60	4	38.1	60	—	34	15.9	9	50	14	2.5	19,800	MBA-M20	125	
0770 10338090		-90	4	38.1	90	—	34	15.9	9	50	14	3.3	20,900			
0770 10525045	BT50 -FMA25.4A	-45	1	25.4	45	—	22	9.5	5	33	10	4.0	25,300	MBA-M12	80	
0770 10525090		-90	2	25.4	90	70	22	9.5	5	33	10	5.0	27,600			
0770 10525150		-150	2	25.4	150	70	22	9.5	5	33	10	6.4	29,900			
0770 10531045	-FMA31.75A	-45	1	31.75	45	—	30	12.7	7	40	10	4.1	25,300	MBA-M16	100	
0770 10531075		-75	2	31.75	75	70	30	12.7	7	40	10	4.9	27,600			
0770 10531105		-105	2	31.75	105	70	30	12.7	7	40	10	5.7	29,900			
0770 10538045	-FMA38.1A	-45	1	38.1	45	—	34	15.9	9	50	14	4.4	25,300	MBA-M20	125	
0770 10538075		-75	1	38.1	75	—	34	15.9	9	50	14	5.6	27,600			
0770 10547075	-FMA47.625A	-75	3	47.625	75	128.57	—	38	25.4	12.5	—	—	7.9	35,650	M16	200
0770 10550045	-FMA50.8A	-45	1	50.8	45	—	36	19.05	10	65	14	5.0	25,300	MBA-M24	160	
0770 10550075		-75	1	50.8	75	—	36	19.05	10	65	14	6.8	27,600			

Incluye el perno de sujeción.
Clamp bolt is Included.

Ejemplo para Ordenar - Ordering Example

BT40	- FMA	25.4A	-	90
Interfaz y diámetro de husillo Shank size		Diámetro Interno D1 D1		Longitud de proyección Projection length (L)

BT
CAT
AHO
HSK-A/E/F/C
HSK-T
C
UTS
Máquinas Especializadas
Specialized Machine
Equipo Relacionado
Related Equipment
Taladro de Biselado & Casquillo
Bush & Chamfering Drill
Milling Chuck
Collet Holder
"R" Zero Holder
Hydraulic Chuck
Shrink Fit
Tapping Chuck
Arbors
Function Holder
Turning Tool
Retention Stud
Tool Shank Dimensions

Face Mill Arbor

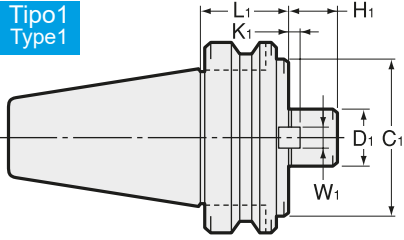
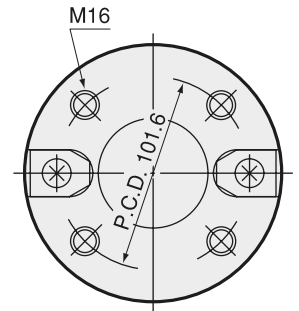
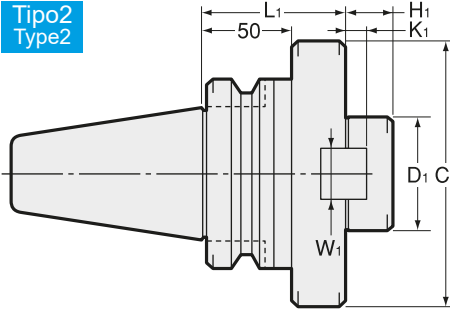
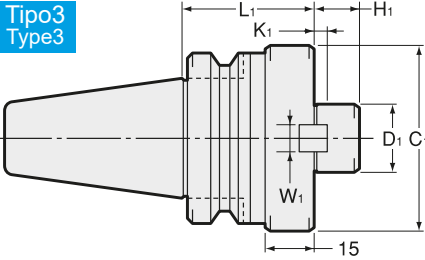
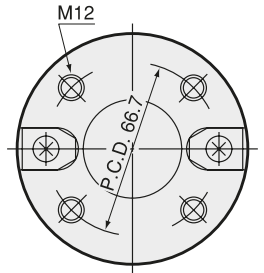
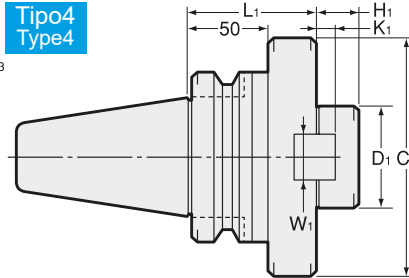
Tipo1
Type1Tipo2
Type2Tipo3
Type3Tipo4
Type4

Medidas Métricas - Metric Sizes

Unidad : Métrico
Unit : Metric

Código Code	Modelo Model	Tipo Type	D1 (h6)	L1	C1	H1	W1	K1	C4	H3	kg	—	Perno de sujeción Clamp Bolt	Ejemplo del diá. de cortador Cutter dia. Example
0770 11127060	BT30 -FMB27A -60	3	27	60	80	26	12	6	33	10	1.5	12,960	MBA-M12	80
0770 11327060	BT40 -FMB27A -60	3	27	60	80	26	12	6	33	10	2.2	16,500	MBA-M12	80
0770 11327090	-90	3	27	90	80	26	12	6	33	10	3.0	17,600	MBA-M12	80
0770 11340060	-FMB40A -60	3	40	60	85	26	16	8.5	50	14	2.5	19,800	MBA-M20	100 125
0770 11527045	BT50 -FMB27A -45	1	27	45	80	26	12	6	33	10	4.2	25,300	MBA-M12	80
0770 11527090	-90	1	27	90	80	26	12	6	33	10	5.9	27,600	MBA-M12	80
0770 11527150	-150	1	27	150	80	26	12	6	33	10	8.3	29,900	MBA-M12	80
0770 11540045	-FMB40A -45	1	40	45	85	26	16	8.5	50	14	4.4	25,300	MBA-M20	100 125
0770 11540075	-75	1	40	75	85	26	16	8.5	50	14	5.8	27,600	MBA-M20	100 125
0770 11540105	-105	1	40	105	85	26	16	8.5	50	14	7.1	29,900	MBA-M20	100 125
0770 11541075	-FMB40FA -75	4	40	75	110	26	16	8.5	50	14	6.8	34,500	M12, MBA-M20	160
0770 11560075	-FMB60A -75	2	60	75	140	25	25.4	12.5	—	—	8.2	40,250	M16	200

Incluye el perno de sujeción.

Clamp bolt is Included.

Ejemplo para Ordenar - Ordering Example

BT30 - FMB27A- 60Interfaz y diámetro de husillo
Shank sizeDiámetro D1
D1Longitud de proyección
Projection length (L)

Medida en Pulgadas - Inch Sizes

Unidad : Métrico
Unit : Metric

Código Code	Modelo Model	Tipo Type	D1 (h6)	L1	C1	H1	W1	K1	C4	H3	kg	—	Perno de sujeción Clamp Bolt	Ejemplo del diá. de cortador Cutter dia. Example
0770 12125060	BT30 -FMB25.4A -60	3	25.4	60	80	26	9.5	5	33	10	1.5	12,960	MBA-M12	80
0770 12325060	BT40 -FMB25.4A -60	3	25.4	60	80	26	9.5	5	33	10	2.2	16,500	MBA-M12	80
0770 12325090	-90	3	25.4	90	80	26	9.5	5	33	10	2.9	17,600	MBA-M12	80
0770 12338060	-FMB38.1A -60	3	38.1	60	85	26	15.9	9	50	14	2.6	19,800	MBA-M20	100 125
0770 12525045	BT50 -FMB25.4A -45	1	25.4	45	80	26	9.5	5	33	10	4.1	25,300	MBA-M12	80
0770 12525090	-90	1	25.4	90	80	26	9.5	5	33	10	5.9	27,600	MBA-M12	80
0770 12525150	-150	1	25.4	150	80	26	9.5	5	33	10	8.4	29,900	MBA-M12	80
0770 12538045	-FMB38.1A -45	1	38.1	45	85	26	15.9	9	50	14	4.4	25,300	MBA-M20	100 125
0770 12538075	-75	1	38.1	75	85	26	15.9	9	50	14	5.7	27,600	MBA-M20	100 125
0770 12538105	-105	1	38.1	105	85	26	15.9	9	50	14	7.1	29,900	MBA-M20	100 125
0770 12539075	-FMB38.1FA -75	4	38.1	75	110	26	15.9	9	50	14	5.7	34,500	M12, MBA-M20	160

Incluye el perno de sujeción.

Clamp bolt is Included.

Ejemplo para Ordenar - Ordering Example

BT30 - FMB25.4A- 60Interfaz y diámetro de husillo
Shank sizeDiámetro D1
D1Longitud de proyección
Projection length (L)

FMC•A

Face Mill Arbor

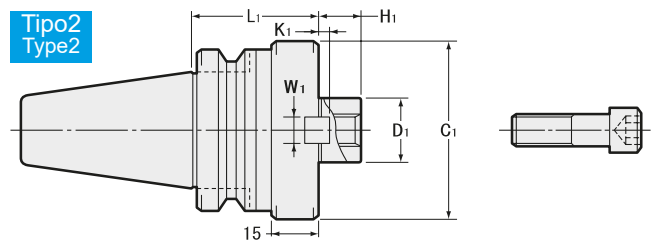
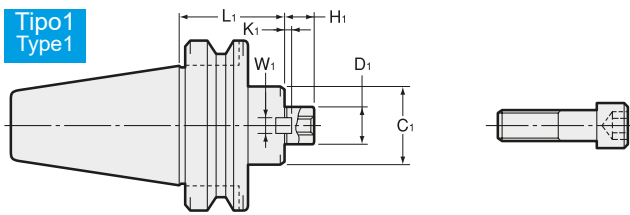

Medidas Métricas - Metric Sizes

Unidad : Métrico
Unit : Metric

Código Code	Modelo Model	Tipo Type	D1 (h6)	L1	C1	H1	W1	K1	kg	—	Perno de sujeción Clamp Bolt JIS B1176	Ejemplo del diámetro de cortador Cutter dia. Example
0770 14125060	BT30 -FMC25.4A -60	2	25.4	60	70	20	9.5	5	1.3	12,960	M12	80
0770 14325060	BT40 -FMC25.4A -60	2	25.4	60	70	20	9.5	5	2.0	16,500	M12	80
0770 14325090	-90	2	25.4	90	70	20	9.5	5	2.7	17,600	M12	80
0770 14338060	-FMC38.1A -60	2	38.1	60	85	22	15.9	7	2.3	16,500	M16	100
0770 14338075	-75	2	38.1	75	85	22	15.9	7	2.6	17,600	M16	100
0770 14525045	BT50 -FMC25.4A -45	1	25.4	45	70	20	9.5	5	4.1	25,300	M12	80
0770 14525090	-90	1	25.4	90	70	20	9.5	5	5.4	27,600	M12	80
0770 14525150	-150	1	25.4	150	70	20	9.5	5	7.2	29,900	M12	80
0770 14538045	-FMC38.1A -45	1	38.1	45	85	22	15.9	7	4.3	25,300	M16	100
0770 14538075	-75	1	38.1	75	85	22	15.9	7	5.5	27,600	M16	100
0770 14538105	-105	1	38.1	105	85	22	15.9	7	6.9	29,900	M16	100

Incluye el perno de sujeción.
Clamp bolt is Included.

Ordering Example

BT30 - FMC 27A - 45

Interfaz y diámetro de husillo

Diámetro D1

Longitud de proyección

Shank size

D1

Projection length (L)

Medida en Pulgadas - Inch Sizes

Unidad : Métrico
Unit : Metric

Código Code	Modelo Model	Tipo Type	D1 (h6)	L1	C1	H1	W1	K1	kg	—	Perno de sujeción Clamp Bolt JIS B1176	Ejemplo del diámetro de cortador Cutter dia. Example
0770 13122045	BT30 -FMC22A -45	1	22	45	45	18	10	5	0.8	12,960	M10	50 63
0770 13322045	BT40 -FMC22A -45	1	22	45	45	18	10	5	1.3	16,500	M10	50 63
0770 13322090	-90	1	22	90	45	18	10	5	1.9	17,600	M10	50 63
0770 13327060	-FMC27A -60	2	27	60	70	20	12	6	2.0	16,500	M12	80
0770 13327090	-90	2	27	90	70	20	12	6	2.8	17,600	M12	80
0770 13332060	-FMC32A -60	2	32	60	85	22	14	7	2.3	16,500	M16	100
0770 13332075	-75	2	32	75	85	22	14	7	2.7	17,600	M16	100
0770 13522060	BT50 -FMC22A -60	1	22	60	45	18	10	5	4.0	25,300	M10	50 63
0770 13522105	-105	1	22	105	45	18	10	5	4.6	27,600	M10	50 63
0770 13522150	-150	1	22	150	45	18	10	5	5.2	29,900	M10	50 63
0770 13527045	-FMC27A -45	1	27	45	70	20	12	6	4.0	25,300	M12	80
0770 13527090	-90	1	27	90	70	20	12	6	5.4	27,600	M12	80
0770 13527150	-150	1	27	150	70	20	12	6	7.2	29,900	M12	80
0770 13532045	-FMC32A -45	1	32	45	85	22	14	7	4.2	25,300	M16	100
0770 13532075	-75	1	32	75	85	22	14	7	5.5	27,600	M16	100
0770 13532105	-105	1	32	105	85	22	14	7	6.9	29,900	M16	100

Incluye el perno de sujeción.
Clamp bolt is Included.

Ordering Example

BT30 - FMC 25.4A - 60

Interfaz y diámetro de husillo

Diámetro D1

Longitud de proyección

Shank size

D1

Projection length (L)

SM1

Shell End Mill Arbor

- Para piña JIS B4214-1975
- For JIS B4214-1975 Shell end mill.

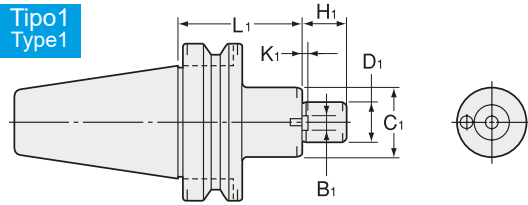
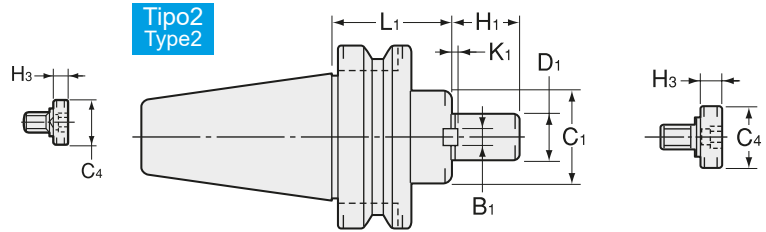
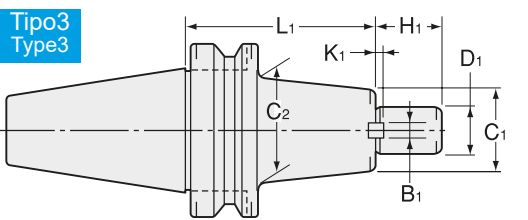
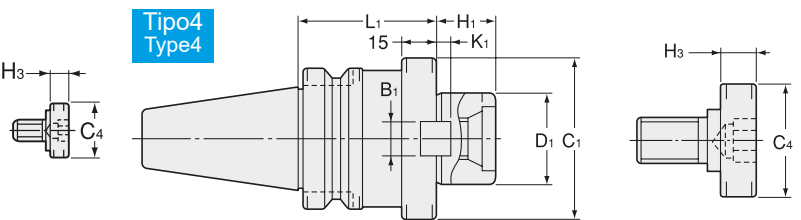
Tipo1
Type1

Tipo2
Type2

Tipo3
Type3

Tipo4
Type4

Medidas Métricas - Metric Sizes

 Unidad : Métrico
Unit : Metric

Código Code	Modelo Model	Tipo Type	D1 (h6)	L1	C1	C2	H1	B1	K1	C4	H3	kg	Perno de sujeción Clamp Bolt	Ejemplo del diá. de cortador Cutter dia. Example
0780 00116030	BT30 -SM1-16 -30	1	16	30	34	—	15	8	5	20	7	0.5	MBA-M8	40
0780 00122030	BT30 -SM1-22 -30	1	22	30	42	—	17	10	5.6	28	9	0.6	MBA-M10	50
0780 00316060	BT40 -SM1-16 -60	1	16	60	34	—	15	8	5	20	7	1.3	MBA-M8	40
0780 00316120	-120	1	16	120	34	—	15	8	5	20	7	1.7	MBA-M8	40
0780 00322060	BT40 -SM1-22 -60	1	22	60	42	—	17	10	5.6	28	9	1.5	MBA-M10	50
0780 00322120	-120	1	22	120	42	—	17	10	5.6	28	9	2.1	MBA-M10	50
0780 00327045	BT40 -SM1-27 -45	2	27	45	48	—	19	12	6.3	33	10	1.4	MBA-M12	63 80
0780 00327105	-105	2	27	105	48	—	19	12	6.3	33	10	2.3	MBA-M12	63 80
0780 00332045	BT40 -SM1-32 -45	2	32	45	58	—	24	14	7	40	10	1.6	MBA-M16	100
0780 00332075	-75	2	32	75	58	—	24	14	7	40	10	2.3	MBA-M16	100
0780 00340060	BT40 -SM1-40 -60	4	40	60	70	—	27	16	8	50	14	2.3	MBA-M20	125
0780 00516075	BT50 -SM1-16 -75	1	16	75	34	—	15	8	5	20	7	4.0	MBA-M8	40
0780 00516120	-120	1	16	120	34	—	15	8	5	20	7	6.3	MBA-M8	40
0780 00522075	BT50 -SM1-22 -75	1	22	75	42	—	17	10	5.6	28	9	4.3	MBA-M10	50
0780 00522120	-120	1	22	120	42	—	17	10	5.6	28	9	4.7	MBA-M10	50
0780 00522180	-180	1	22	180	42	—	17	10	5.6	28	9	5.3	MBA-M10	50
0780 00527060	BT50 -SM1-27 -60	2	27	60	48	—	19	12	6.3	33	10	4.2	MBA-M12	63 80
0780 00527105	-105	3	27	105	48	60	19	12	6.3	33	10	5.0	MBA-M12	63 80
0780 00527150	-150	3	27	150	48	60	19	12	6.3	33	10	5.9	MBA-M12	63 80
0780 00532045	BT50 -SM1-32 -45	2	32	45	58	—	24	14	7	40	10	4.2	MBA-M16	100
0780 00532075	-75	3	32	75	58	70	24	14	7	40	10	4.8	MBA-M16	100
0780 00532105	-105	3	32	105	58	70	24	14	7	40	10	5.6	MBA-M16	100
0780 00540075	BT50 -SM1-40 -75	3	40	75	70	80	27	16	8	50	14	5.5	MBA-M20	125
0780 00540105	-105	3	40	105	70	80	27	16	8	50	14	6.4	MBA-M20	125

 Incluye el perno de sujeción.
Clamp bolt is Included.

Ordering Example

BT30 - SM1 - 16 - 30

 Interfaz y
diámetro de husillo

 Diámetro
D1

 Longitud de
proyección

Shank size

D1

 Projection
length (L)

Pulgada a métrico → Pulgada × 25.4

Métrico a pulgada → Métrico ÷ 25.4 ó métrico por 0.03937



Tamaños especiales / personalizados bajo pedido

Shell End Mill Arbor

- Para piña JIS B4214-1966
- For JIS B4214-1966 Shell end mill.

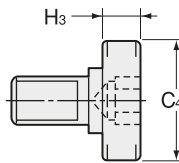
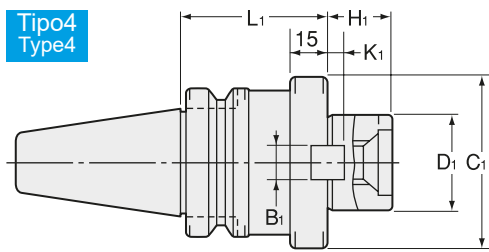
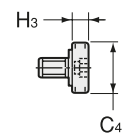
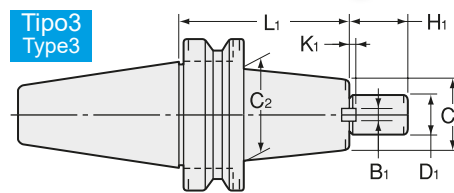
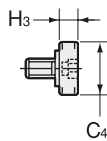
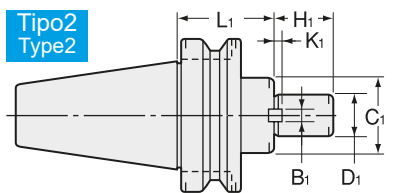
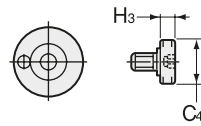
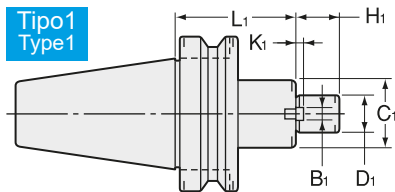

Medidas Métricas - Metric Sizes

Unidad : Métrico
Unit : Metric

Código Code	Modelo Model	Tipo Type	D1 (h6)	L1	C1	C2	H1	B1	K1	C4	H3	kg	Perno de sujeción Clamp Bolt	Ejemplo del diá. de cortador Cutter dia. Example
0780 01116030	BT30 -SMA16 -30	1	16	30	34	—	17	8	3	20	7	0.5	MBA-M 8	35 40
0780 01122030	BT30 -SMA22 -30	1	22	30	42	—	27	8	3.5	28	9	0.6	MBA-M10	45 50
0780 01316060	BT40 -SMA16 -60	1	16	60	34	—	17	8	3	20	7	1.3	MBA-M 8	35 40
0780 01316120	-120	1	16	120	34	—	17	8	3	20	7	1.7	MBA-M 8	35 40
0780 01322060	BT40 -SMA22 -60	1	22	60	42	—	27	8	3.5	28	9	1.4	MBA-M10	45 50
0780 01322120	-120	1	22	120	42	—	27	8	3.5	28	9	2.2	MBA-M10	45 50
0780 01327045	BT40 -SMA27 -45	2	27	45	50	—	36	10	4	33	10	1.4	MBA-M12	60 75
0780 01327105	-105	2	27	105	50	—	36	10	4	33	10	2.4	MBA-M12	60 75
0780 01332045	BT40 -SMA32 -45	2	32	45	60	—	38	10	4.5	40	10	1.7	MBA-M16	100
0780 01332075	-75	2	32	75	60	—	38	10	4.5	40	10	2.3	MBA-M16	100
0780 01340060	BT40 -SMA40 -60	4	40	60	80	—	38	12	5	50	14	2.0	MBA-M20	125
0780 01516075	BT50 -SMA16 -75	1	16	75	34	—	17	8	3	20	7	4.0	MBA-M 8	35 40
0780 01516120	-120	1	16	120	34	—	17	8	3	20	7	4.3	MBA-M 8	35 40
0780 01522075	BT50 -SMA22 -75	1	22	75	42	—	27	8	3.5	28	9	4.3	MBA-M10	45 50
0780 01522120	-120	1	22	120	42	—	27	8	3.5	28	9	4.7	MBA-M10	45 50
0780 01522180	-180	1	22	180	42	—	27	8	3.5	28	9	5.4	MBA-M10	45 50
0780 01527060	BT50 -SMA27 -60	2	27	60	50	—	36	10	4	33	10	4.3	MBA-M12	60 75
0780 01527105	-105	3	27	105	50	60	36	10	4	33	10	5.2	MBA-M12	60 75
0780 01527150	-150	3	27	150	50	60	36	10	4	33	10	6.0	MBA-M12	60 75
0780 01532045	BT50 -SMA32 -45	2	32	45	60	—	38	10	4.5	40	10	4.2	MBA-M16	100
0780 01532075	-75	3	32	75	60	70	38	10	4.5	40	10	5.0	MBA-M16	100
0780 01532105	-105	3	32	105	60	70	38	10	4.5	40	10	5.7	MBA-M16	100
0780 01540045	BT50 -SMA40 -45	2	40	45	80	—	38	12	5	50	14	4.3	MBA-M20	125
0780 01540075	-75	2	40	75	80	—	38	12	5	50	14	5.7	MBA-M20	125

Incluye el perno de sujeción.
Clamp bolt is Included.

Pulgada a métrico → Pulgada × 25.4
Métrico a pulgada → Métrico ÷ 25.4 ó métrico por 0.03937



Tamaños especiales / personalizados bajo pedido

Medida en Pulgadas - Inch Sizes

Unidad : Métrico
Unit : Metric

Código Code	Modelo Model	Tipo Type	D1 (h6)	L1	C1	C2	H1	B1	K1	C4	H3	kg	Perno de sujeción Clamp Bolt	Ejemplo del diá. de cortador Cutter dia. Example
0780 02115030	BT30 -SMA15.875 -30	1	15.875	30	34	—	17	8	3	20	7	0.6	MBA-M 8	35 40
0780 02122030	BT30 -SMA22.225 -30	1	22.225	30	42	—	27	8	3.5	28	9	1.0	MBA-M10	45 50
0780 02315060	BT40 -SMA15.875 -60	1	15.875	60	34	—	17	8	3	20	7	1.3	MBA-M 8	35 40
0780 02315120	-120	1	15.875	120	34	—	17	8	3	20	7	1.7	MBA-M 8	35 40
0780 02322060	BT40 -SMA22.225 -60	1	22.225	60	42	—	27	8	3.5	28	9	1.5	MBA-M10	45 50
0780 02322120	-120	1	22.225	120	42	—	27	8	3.5	28	9	2.1	MBA-M10	45 50
0780 02325045	BT40 -SMA25.4 -45	2	25.4	45	50	—	36	10	4	33	10	1.4	MBA-M12	60 75
0780 02325105	-105	2	25.4	105	50	—	36	10	4	33	10	2.3	MBA-M12	60 75
0780 02331045	BT40 -SMA31.75 -45	2	31.75	45	60	—	38	10	4.5	40	10	1.6	MBA-M16	100
0780 02331075	-75	2	31.75	75	60	—	38	10	4.5	40	10	2.3	MBA-M16	100
0780 02338060	BT40 -SMA38.1 -60	4	38.1	60	80	—	38	12	5	50	14	3.0	MBA-M20	125
0780 02515075	BT50 -SMA15.875 -75	1	15.875	75	34	—	17	8	3	20	7	4.2	MBA-M 8	35 40
0780 02515120	-120	1	15.875	120	34	—	17	8	3	20	7	5.8	MBA-M 8	35 40
0780 02522075	BT50 -SMA22.225 -75	1	22.225	75	42	—	27	8	3.5	28	9	4.3	MBA-M10	45 50
0780 02522120	-120	1	22.225	120	42	—	27	8	3.5	28	9	4.7	MBA-M10	45 50
0780 02522180	-180	1	22.225	180	42	—	27	8	3.5	28	9	5.5	MBA-M10	45 50
0780 02525060	BT50 -SMA25.4 -60	2	25.4	60	50	—	36	10	4	33	10	4.3	MBA-M12	60 75
0780 02525105	-105	3	25.4	105	50	60	36	10	4	33	10	5.2	MBA-M12	60 75
0780 02525150	-150	3	25.4	150	50	60	36	10	4	33	10	6.0	MBA-M12	60 75
0780 02531045	BT50 -SMA31.75 -45	2	31.75	45	60	—	38	10	4.5	40	10	4.2	MBA-M16	100
0780 02531075	-75	3	31.75	75	60	70	38	10	4.5	40	10	4.9	MBA-M16	100
0780 02531105	-105	3	31.75	105	60	70	38	10	4.5	40	10	6.2	MBA-M16	100
0780 02538045	BT50 -SMA38.1 -45	2	38.1	45	80	—	38	12	5	50	14	4.3	MBA-M20	125
0780 02538075	-75	2	38.1	75	80	—	38	12	5	50	14	5.5	MBA-M20	125

Incluye el perno de sujeción.
Clamp bolt is Included.

Ejemplo para Ordenar - Ordering Example

BT30 - SMA 16 - 30Interfaz y
diámetro de husillo

Diámetro D1

Longitud de
proyección

Shank size

D1

Projection
length (L)

SMB

Shell End Mill Arbor

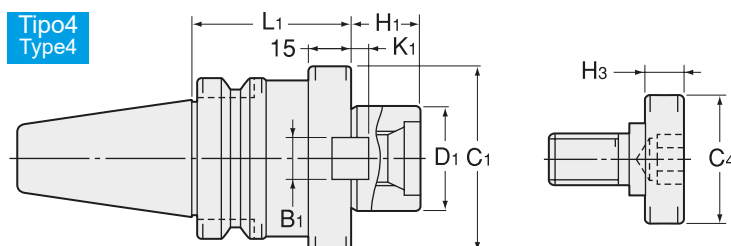
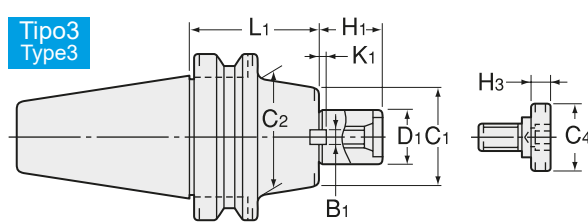
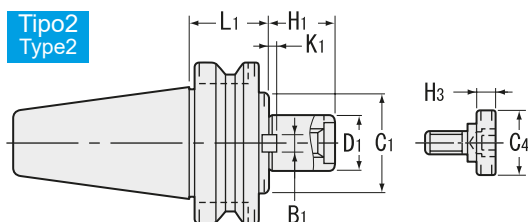
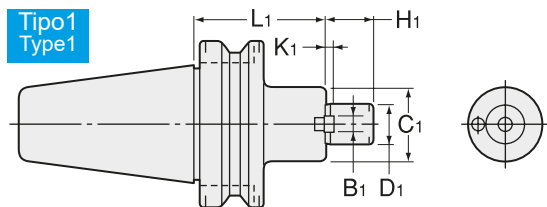

Medidas Métricas - Metric Sizes

Unidad : Métrico
Unit : Metric

Código Code	Modelo Model	Tipo Type	D1 (h6)	L1	C1	C2	H1	B1	K1	C4	H3	kg	Perno de sujeción Clamp Bolt	Ejemplo del diá. de cortador Cutter dia. Example
0780 03122030	BT30 -SMB22.225 -30	1	22.225	30	45	—	17	8	3.5	28	9	0.6	MBA-M10	50
0780 03322045	BT40 -SMB22.225 -45	1	22.225	45	45	—	17	8	3.5	28	9	1.3	MBA-M10	50
0780 03322120	-120	1	22.225	120	45	—	17	8	3.5	28	9	2.2	MBA-M10	50
0780 03331045	BT40 -SMB31.75 -45	2	31.75	45	60	—	30	12.7	4.5	40	10	1.7	MBA-M16	75
0780 03331075	-75	2	31.75	75	60	—	30	12.7	4.5	40	10	2.3	MBA-M16	75
0780 03338060	BT40 -SMB38.1 -60	4	38.1	60	80	—	36	15.9	5	50	14	2.8	MBA-M20	100
0780 03522060	BT50 -SMB22.225 -60	1	22.225	60	45	—	17	8	3.5	28	9	4.3	MBA-M10	50
0780 03522120	-120	1	22.225	120	45	—	17	8	3.5	28	9	4.8	MBA-M10	50
0780 03522180	-180	1	22.225	180	45	—	17	8	3.5	28	9	5.7	MBA-M10	50
0780 03531045	BT50 -SMB31.75 -45	2	31.75	45	60	—	30	12.7	4.5	40	10	4.2	MBA-M16	75
0780 03531075	-75	3	31.75	75	60	70	30	12.7	4.5	40	10	4.9	MBA-M16	75
0780 03531105	-105	3	31.75	105	60	70	30	12.7	4.5	40	10	6.2	MBA-M16	75
0780 03538045	BT50 -SMB38.1 -45	2	38.1	45	80	—	36	15.9	5	50	14	4.3	MBA-M20	100
0780 03538075	-75	2	38.1	75	80	—	36	15.9	5	50	14	5.5	MBA-M20	100

Incluye el perno de sujeción.
Clamp bolt is Included.

Ejemplo para Ordenar - Ordering Example

BT30 - SMB 22.225 - 30

Interfaz y diámetro de husillo

Diámetro D1

Longitud de proyección

Shank size

D1

Projection length (L)

Pulgada a métrico → Pulgada × 25.4
Métrico a pulgada → Métrico ÷ 25.4 ó métrico por 0.03937



Tamaños especiales / personalizados bajo pedido

BT

BT

CAT

AHO

HSK-A/E/F/C

HSK-T

C

UTS

Máquinas Especializadas
Specialized Machine

Equipo Relacionado
Related Equipment

Taladro de Biselado & Casquillo
Bush & Chamfering Drill

Milling Chuck

Collet Holder

"R" Zero Holder

Hydraulic Chuck

Shrink Fit

Tapping Chuck

Arbors

Function Holder

Turning Tool

Retention Stud

Tool Shank Dimensions

Shell End Mill Arbor

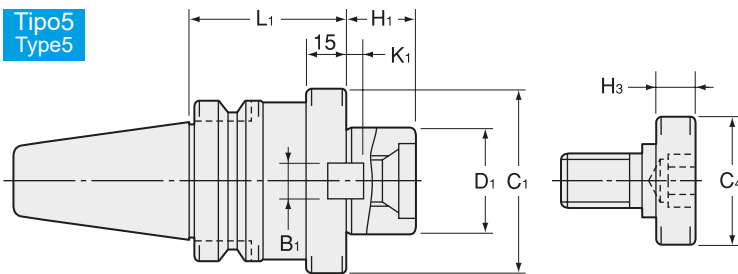
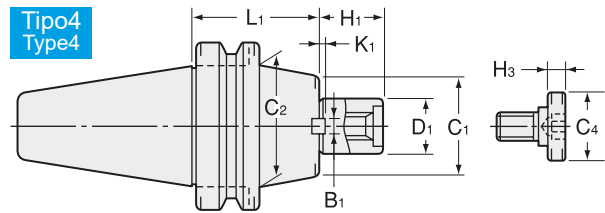
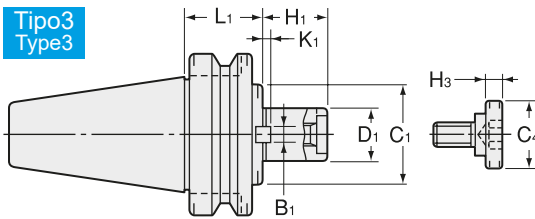
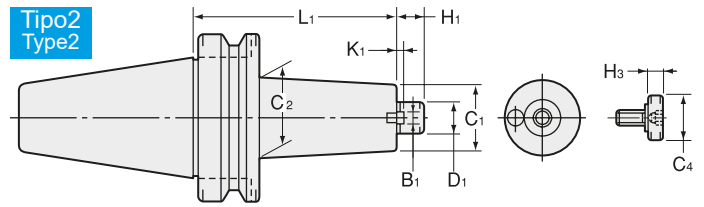
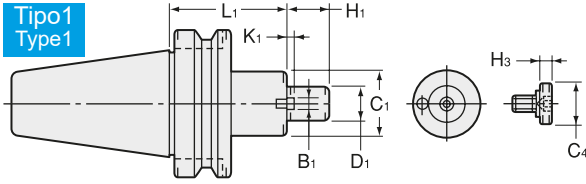
**Medidas Métricas** - Metric SizesUnidad : Métrico
Unit : Metric

Código Code	Modelo Model	Tipo Type	D1 (h6)	L1	C1	C2	H1	B1	K1	C4	H3	kg	Perno de sujeción Clamp Bolt	Ejemplo del diá de cortador Cutter dia. Example
0780 04319060	BT40 -SMC19.05 -60	1	19.05	60	40	—	16	8	3.5	28	9	2.4	MBA-M10	50
0780 04319120	-120	2	19.05	120	40	45	16	8	3.5	28	9	2.9	MBA-M10	50
0780 04331045	BT40 -SMC31.75 -45	3	31.75	45	60	—	18	12.7	4.5	40	10	1.6	MBA-M16	75
0780 04331105	-105	3	31.75	105	60	—	18	12.7	4.5	40	10	2.9	MBA-M16	75
0780 04338060	BT40 -SMC38.1 -60	5	38.1	60	80	—	24	15.9	5	50	14	2.4	MBA-M20	100
0780 04338090	-90	5	38.1	90	80	—	24	15.9	5	50	14	3.1	MBA-M20	100
0780 04519060	BT50 -SMC19.05 -60	1	19.05	60	40	—	16	8	3.5	28	9	4.0	MBA-M10	50
0780 04519120	-120	2	19.05	120	40	45	16	8	3.5	28	9	4.7	MBA-M10	50
0780 04519180	-180	2	19.05	180	40	45	16	8	3.5	28	9	5.6	MBA-M10	50
0780 04531045	BT50 -SMC31.75 -45	3	31.75	45	60	—	18	12.7	4.5	40	10	4.0	MBA-M16	75
0780 04531075	-75	4	31.75	75	60	70	18	12.7	4.5	40	10	4.8	MBA-M16	75
0780 04531105	-105	4	31.75	105	60	70	18	12.7	4.5	40	10	6.2	MBA-M16	75
0780 04538045	BT50 -SMC38.1 -45	3	38.1	45	80	—	24	15.9	5	50	14	4.3	MBA-M20	100
0780 04538075	-75	3	38.1	75	80	—	24	15.9	5	50	14	5.5	MBA-M20	100

Incluye el perno de sujeción.
Clamp bolt is Included.

Ejemplo para Ordenar - Ordering Example**BT50 - SMC 19.05 - 60**Interfaz y
diámetro de husillo

Diámetro D1

Longitud de
proyección

Shank size

D1

Projection
length (L)

Pulgada a métrico → Pulgada × 25.4

Métrico a pulgada → Métrico ÷ 25.4 ó métrico por 0.03937



Tamaños especiales / personalizados bajo pedido

Side Cutter Arbor

- Para cortador lateral JIS y sierra metálica.
- For JIS side cutter and metal saw.

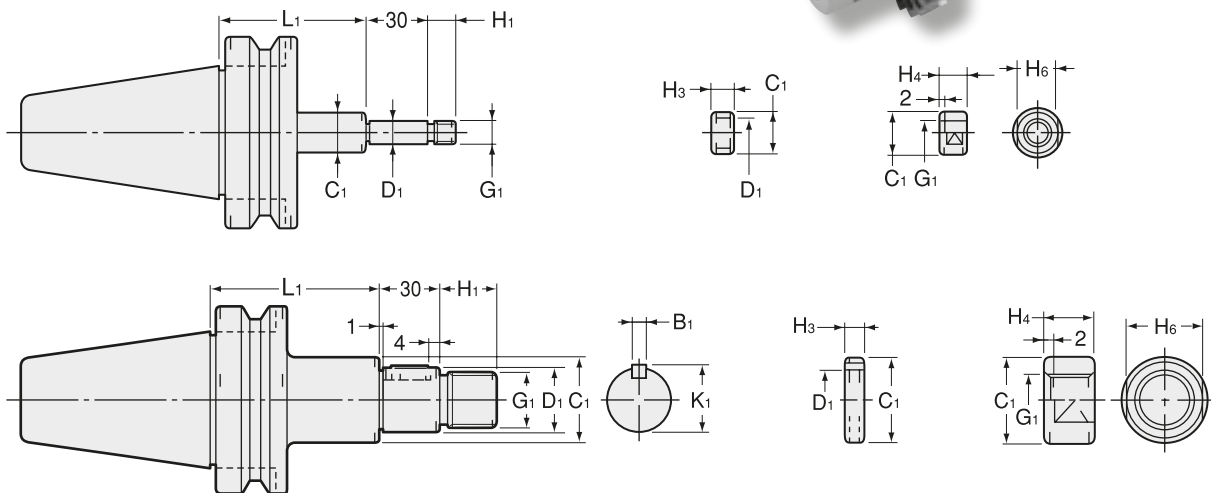
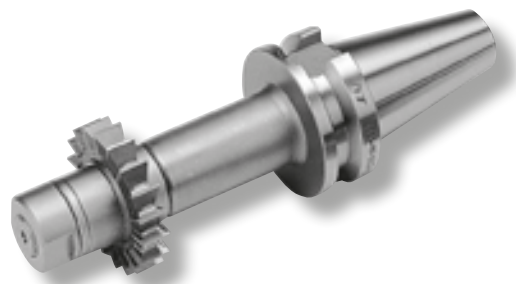

Medidas Métricas - Metric Sizes

Unidad : Métrico
Unit : Metric

Código Code	Modelo Model	Tipo Type	D1 (h6)	L1	C1	G1	H1	B1	K1	H3	H4	H6	kg	Ejemplo del diá. de cortador Cutter dia. Example
0790 00113075	BT30 -SCA13 -75	1	13	75	20	M12 × 1.25	15	—	—	3,5,7,8,10,12	12	17	0.7	50
0790 00116075	BT30 -SCA16 -75	2	16	75	26	M14 × 1.5	16	4	17.2	3,5,7,8,10,12	13	22	0.9	50 ~ 63
0790 00122075	BT30 -SCA22 -75	2	22	75	34	M20 × 1.5	21	6	23.6	3,5,7,8,10,12	18	30	1.2	60 ~ 125
0790 00313060	BT40 -SCA13 -60	1	13	60	20	M12 × 1.25	15	—	—	3,5,7,8,10,12	12	17	1.4	50
0790 00313090	-90	1	13	90	20	M12 × 1.25	15	—	—	3,5,7,8,10,12	12	17	1.7	50
0790 00316075	BT40 -SCA16 -75	2	16	75	26	M14 × 1.5	16	4	17.2	3,5,7,8,10,12	13	22	1.4	50 ~ 63
0790 00316105	-105	2	16	105	26	M14 × 1.5	16	4	17.2	3,5,7,8,10,12	13	22	1.6	50 ~ 63
0790 00322075	BT40 -SCA22 -75	2	22	75	34	M20 × 1.5	21	6	23.6	3,5,7,8,10,12	18	30	1.7	60 ~ 125
0790 00322120	-120	2	22	120	34	M20 × 1.5	21	6	23.6	3,5,7,8,10,12	18	30	2.1	60 ~ 125
0790 00327075	BT40 -SCA27 -75	2	27	75	40	M24 × 2	25	7	29	3,5,7,8,10,12	21	32	2.0	75 ~ 100
0790 00327120	-120	2	27	120	40	M24 × 2	25	7	29	3,5,7,8,10,12	21	32	2.4	75 ~ 100
0790 00332090	BT40 -SCA32 -90	2	32	90	46	M30 × 2	30	8	34	3,5,7,8,10,12	26	41	2.6	100 ~ 250
0790 00513075	BT50 -SCA13 -75	1	13	75	20	M12 × 1.25	15	—	—	3,5,7,8,10,12	12	17	4.3	50
0790 00513105	-105	1	13	105	20	M12 × 1.25	15	—	—	3,5,7,8,10,12	12	17	4.4	50
0790 00516090	BT50 -SCA16 -90	2	16	90	26	M14 × 1.5	16	4	17.2	3,5,7,8,10,12	13	22	4.1	50 ~ 63
0790 00516120	-120	2	16	120	26	M14 × 1.5	16	4	17.2	3,5,7,8,10,12	13	22	4.2	50 ~ 63
0790 00522090	BT50 -SCA22 -90	2	22	90	34	M20 × 1.5	21	6	23.6	3,5,7,8,10,12	18	30	4.4	60 ~ 125
0790 00522135	-135	2	22	135	34	M20 × 1.5	21	6	23.6	3,5,7,8,10,12	18	30	4.7	60 ~ 125
0790 00527090	BT50 -SCA27 -90	2	27	90	40	M24 × 2	25	7	29	3,5,7,8,10,12	21	32	4.5	75 ~ 100
0790 00527135	-135	2	27	135	40	M24 × 2	25	7	29	3,5,7,8,10,12	21	32	4.9	75 ~ 100
0790 00532090	BT50 -SCA32 -90	2	32	90	46	M30 × 2	30	8	34	3,5,7,8,10,12	26	41	4.9	100 ~ 250
0790 00532135	-135	2	32	135	46	M30 × 2	30	8	34	3,5,7,8,10,12	26	41	5.7	100 ~ 250
0790 00540090	BT50 -SCA40 -90	2	40	90	55	M36 × 3	36	10	42.5	3,5,7,8,10,12	31	46	5.9	150 ~ 315
0790 00540135	-135	2	40	135	55	M36 × 3	36	10	42.5	3,5,7,8,10,12	31	46	6.7	150 ~ 315

Medida en Pulgadas - Inch Sizes

Unidad : Métrico
Unit : Metric

Código Code	Modelo Model	Tipo Type	D1 (h6)	L1	C1	G1	H1	B1	K1	H3	H4	H6	kg	Ejemplo del día. de cortador Cutter dia. Example
0790 01112075	BT30 -SCA12.7 -75	1	12.7	75	20	M12 × 1.25	15	—	—	3,5,7,8,10,12	12	17	1.0	50
0790 01115075	BT30 -SCA15.875 -75	2	15.875	75	26	M14 × 1.5	16	3.18	17.42	3,5,7,8,10,12	13	22	1.2	50 ~ 63
0790 01122075	BT30 -SCA22.225 -75	2	22.225	75	34	M20 × 1.5	21	3.18	23.82	3,5,7,8,10,12	18	30	1.5	60 ~ 63
0790 01312060	BT40 -SCA12.7 -60	1	12.7	60	20	M12 × 1.25	15	—	—	3,5,7,8,10,12	12	17	1.4	50
0790 01312090	-90	1	12.7	90	20	M12 × 1.25	15	—	—	3,5,7,8,10,12	12	17	1.7	50
0790 01315075	BT40 -SCA15.875 -75	2	15.875	75	26	M14 × 1.5	16	3.18	17.42	3,5,7,8,10,12	13	22	1.4	50 ~ 63
0790 01315105	-105	2	15.875	105	26	M14 × 1.5	16	3.18	17.42	3,5,7,8,10,12	13	22	1.5	50 ~ 63
0790 01322075	BT40 -SCA22.225 -75	2	22.225	75	34	M20 × 1.5	21	3.18	23.82	3,5,7,8,10,12	18	30	1.7	60 ~ 63
0790 01322120	-120	2	22.225	120	34	M20 × 1.5	21	3.18	23.82	3,5,7,8,10,12	18	30	2.0	60 ~ 63
0790 01325075	BT40 -SCA25.4 -75	2	25.4	75	40	M24 × 2	25	6.35	27.78	3,5,7,8,10,12	21	32	2.0	75 ~ 125
0790 01325120	-120	2	25.4	120	40	M24 × 2	25	6.35	27.78	3,5,7,8,10,12	21	32	2.4	75 ~ 125
0790 01331090	BT40 -SCA31.75 -90	2	31.75	90	46	M30 × 2	30	7.92	34.92	3,5,7,8,10,12	26	41	2.6	100 ~ 250
0790 01512075	BT50 -SCA12.7 -75	1	12.7	75	20	M12 × 1.25	15	—	—	3,5,7,8,10,12	12	17	4.3	50
0790 01512105	-105	1	12.7	105	20	M12 × 1.25	15	—	—	3,5,7,8,10,12	12	17	4.4	50
0790 01515090	BT50 -SCA15.875 -90	2	15.875	90	26	M14 × 1.5	16	3.18	17.42	3,5,7,8,10,12	13	22	4.2	50 ~ 63
0790 01515120	-120	2	15.875	120	26	M14 × 1.5	16	3.18	17.42	3,5,7,8,10,12	13	22	4.4	50 ~ 63
0790 01522090	BT50 -SCA22.225 -90	2	22.225	90	34	M20 × 1.5	21	3.18	23.82	3,5,7,8,10,12	18	30	4.4	60 ~ 63
0790 01522135	-135	2	22.225	135	34	M20 × 1.5	21	3.18	23.82	3,5,7,8,10,12	18	30	4.7	60 ~ 63
0790 01525090	BT50 -SCA25.4 -90	2	25.4	90	40	M24 × 2	25	6.35	27.78	3,5,7,8,10,12	21	32	4.5	75 ~ 125
0790 01525135	-135	2	25.4	135	40	M24 × 2	25	6.35	27.78	3,5,7,8,10,12	21	32	4.9	75 ~ 125
0790 01531090	BT50 -SCA31.75 -90	2	31.75	90	46	M30 × 2	30	7.92	34.92	3,5,7,8,10,12	26	41	4.7	100 ~ 250
0790 01531135	-135	2	31.75	135	46	M30 × 2	30	7.92	34.92	3,5,7,8,10,12	26	41	5.2	100 ~ 250
0790 01538090	BT50 -SCA38.1 -90	2	38.1	90	55	M36 × 3	36	9.52	42.06	3,5,7,8,10,12	31	46	4.9	150 ~ 315
0790 01538135	-135	2	38.1	135	55	M36 × 3	36	9.52	42.06	3,5,7,8,10,12	31	46	5.9	150 ~ 315

Incluye una tuerca ciega de sujeción y espaciadores (en medida 3, 5, 7, 8, 10 y 12/ uno de cada uno).
One clamp nut and spacers (size 3, 5, 7, 8, 10, and 12 / one each) are included.

Ejemplo para Ordenar - Ordering Example

BT30 - SCA 12.7 - 75

Interfaz y diámetro de husillo

Diámetro D1

Longitud de proyección

Shank size

D1

Projection length (L)

- Portaherramienta sin llaves para zanco Jacobs
- Arbor for Jacobs taper keyless chuck.

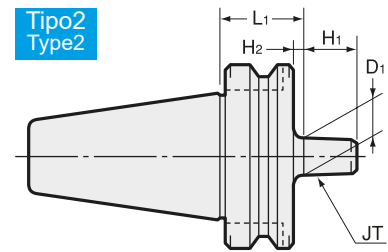
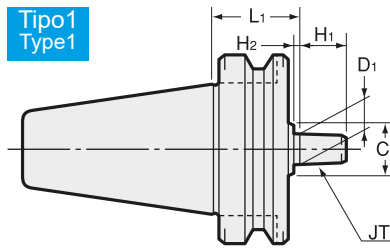

Medidas Métricas - Metric Sizes

Unidad : Métrico
Unit : Metric

Código Code	Modelo Model	Tipo Type	Medida JT Size JT	L1	D1	C1	H1	H2	kg
0750 00101030	BT30 -JTA1 -30	1	1	30	9.754	30	15	3	0.5
0750 00122030	BT30 -JTA2S -30	1	2 corto / short	30	13.940	30	18	3	0.5
0750 00102030	BT30 -JTA2 -30	1	2	30	14.199	30	20	4	0.5
0750 00133030	BT30 -JTA33 -30	1	33	30	15.850	30	24	4	0.5
0750 00106030	BT30 -JTA6 -30	1	6	30	17.170	30	24	4	0.5
0750 00103030	BT30 -JTA3 -30	1	3	30	20.599	35	28	5	0.5
0750 00301045	BT40 -JTA1 -45	1	1	45	9.754	30	15	3	1.1
0750 00301090	-90	1	1	90	9.754	30	15	3	1.4
0750 00322045	BT40 -JTA2S -45	1	2 corto / short	45	13.940	30	18	3	1.1
0750 00322090	-90	1	2 corto / short	90	13.940	30	18	3	1.4
0750 00302045	BT40 -JTA2 -45	1	2	45	14.199	30	20	4	1.1
0750 00302090	-90	1	2	90	14.199	30	20	4	1.4
0750 00333045	BT40 -JTA33 -45	1	33	45	15.850	30	24	4	1.1
0750 00333090	-90	1	33	90	15.850	30	24	4	1.4
0750 00306045	BT40 -JTA6 -45	1	6	45	17.170	30	24	4	1.2
0750 00306090	-90	1	6	90	17.170	30	24	4	1.4
0750 00303045	BT40 -JTA3 -45	1	3	45	20.599	35	28	5	1.2
0750 00303090	-90	1	3	90	20.599	35	28	5	1.5
0750 00501045	BT50 -JTA1 -45	1	1	45	9.754	30	15	3	3.7
0750 00501105	-105	1	1	105	9.754	30	15	3	4.1
0750 00522045	BT50 -JTA2S -45	1	2 corto / short	45	13.940	30	18	3	4.0
0750 00522105	-105	1	2 corto / short	105	13.940	30	18	3	4.1
0750 00502045	BT50 -JTA2 -45	1	2	45	14.199	30	20	4	4.0
0750 00502105	-105	1	2	105	14.199	30	20	4	4.4
0750 00533045	BT50 -JTA33 -45	1	33	45	15.850	30	24	4	3.8
0750 00533105	-105	1	33	105	15.850	30	24	4	4.4
0750 00506045	BT50 -JTA6 -45	1	6	45	17.170	30	24	4	4.0
0750 00506105	-105	1	6	105	17.170	30	24	4	4.4
0750 00503045	BT50 -JTA3 -45	2	3	45	20.599	—	28	7	4.0
0750 00503105	-105	1	3	105	20.599	35	28	5	4.6

Ejemplo para Ordenar - Ordering Example

BT30 - JTA1 - 30

Interfaz y diámetro de husillo

Medida JT

Longitud de proyección

Shank size

Size JT

Projection length (L)

Morse Taper Holder

- Portaherramienta para zanco Morse con espiga
- For Morse taper shank with tang.

Tipo1
Type1

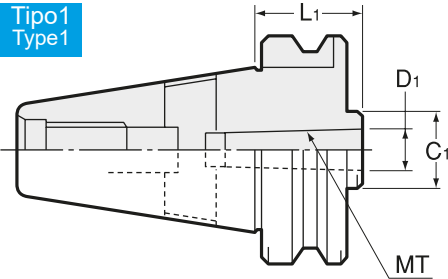

Tipo2
Type2

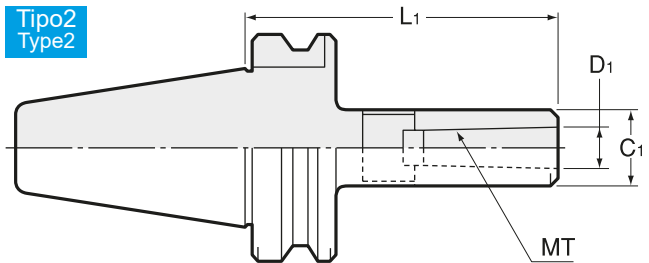

Medidas Métricas - Metric Sizes

Unidad : Métrico
Unit : Metric

Código Code	Modelo Model	Tipo Type	Medida MT Size MT	L1	D1	C1	kg
0760 00101045	BT30 -MTA1 -45	1	1	45	12.065	25	0.5
0760 00102060	BT30 -MTA2 -60	1	2	60	17.780	32	0.5
0760 00103075	BT30 -MTA3 -75	1	3	75	23.825	40	0.7
0760 00301045	BT40 -MTA1 -45	1	1	45	12.065	25	1.0
0760 00301120	-120	2	1	120	12.065	25	1.3
0760 00302045	BT40 -MTA2 -45	1	2	45	17.780	32	1.0
0760 00302120	-120	2	2	120	17.780	32	1.4
0760 00303075	BT40 -MTA3 -75	1	3	75	23.825	40	1.2
0760 00303135	-135	2	3	135	23.825	40	1.8
0760 00304090	BT40 -MTA4 -90	1	4	90	31.267	50	1.4
0760 00304165	-165	2	4	165	31.267	50	2.4
0760 00501045	BT50 -MTA1 -45	1	1	45	12.065	25	3.6
0760 00501120	-120	2	1	120	12.065	25	3.8
0760 00501180	-180	2	1	180	12.065	25	3.9
0760 00502045	BT50 -MTA2 -45	1	2	45	17.780	32	3.6
0760 00502135	-135	2	2	135	17.780	32	4.0
0760 00502180	-180	2	2	180	17.780	32	4.2
0760 00503045	BT50 -MTA3 -45	1	3	45	23.825	40	3.5
0760 00503150	-150	2	3	150	23.825	40	4.3
0760 00503180	-180	2	3	180	23.825	40	4.5
0760 00504075	BT50 -MTA4 -75	1	4	75	31.267	50	3.6
0760 00504180	-180	2	4	180	31.267	50	5.0
0760 00505105	BT50 -MTA5 -105	1	5	105	44.399	65	3.9
0760 00505210	-210	2	5	210	44.399	65	6.3

Ejemplo para Ordenar - Ordering Example

BT30 - MTA1 - 45

Interfaz y
diámetro de husillo

Medida MT

Longitud de
proyección

Shank size

Size MT

Projection
length (L)

MTB

Morse Taper Holder

- Portaherramienta para zanco Morse con tornillo de extracción.
- For Morse taper shank with draw-in screw.

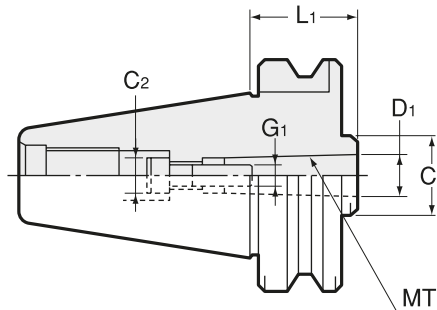

Medidas Métricas - Metric Sizes

Unidad : Métrico
Unit : Metric

Código Code	Modelo Model	Medida MT Size MT	L1	D1	C1	C2	G1	kg
0760 01101045	BT30 -MTB1 -45	1	45	12.065	25	10	M6	0.5
0760 01301045	BT40 -MTB1 -45	1	45	12.065	25	10	M6	1.1
0760 01302045	BT40 -MTB2 -45	2	45	17.780	32	13	M10	1.0
0760 01501045	BT50 -MTB1 -45	1	45	12.065	25	10	M6	3.7
0760 01502045	BT50 -MTB2 -45	2	45	17.780	32	16	M10	3.7
0760 01503060	BT50 -MTB3 -60	3	60	23.825	40	18	M12	3.7
0760 01504075	BT50 -MTB4 -75	4	75	31.267	50	20.5	M16	3.7

Ejemplo para Ordenar - Ordering Example

BT30	-	MTB1	-	45
Interfaz y diámetro de husillo Shank size		Medida MT Size MT		Longitud de proyección Projection length (L)

KHE/BT

BT Shank For Stub Holder

- Portaherramienta de base de cambio rápido donde cabe el portaherramienta de zanco recto KH-E.
- Quick-changeable base holder that accommodates KH-E type stub holder.

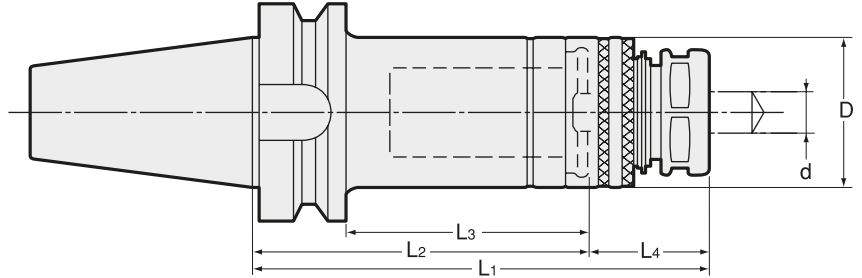

Medidas Métricas - Metric Sizes

Unidad : Métrico
Unit : Metric

Código Code	Modelo Model	d	L1	L2	L3	L4	D	kg	Portaherramienta de zanco recto Stub holder
2720 10016075	BT30 -KH16E -75 ※	2.5 ~ 9.0	75	40	18	35	32	0.5	KH-16E
2720 10016090	-90	2.5 ~ 9.0	90	55	33	35	32	0.5	
2720 10016105	-105	2.5 ~ 9.0	105	70	48	35	32	0.6	
2720 10019075	BT30 -KH19E -75 ※	2.5 ~ 9.0	75	40	18	35	35	0.4	KH-19E
2720 10019090	-90	2.5 ~ 9.0	90	55	33	35	35	0.5	
2720 10019105	-105	2.5 ~ 9.0	105	70	48	35	35	0.6	
2720 10020075	BT30 -KH20E -75 ※	2.5 ~ 9.0	75	40	18	35	35	0.5	KH-20E
2720 10020090	-90	2.5 ~ 9.0	90	55	33	35	35	0.5	
2720 10020105	-105	2.5 ~ 9.0	105	70	48	35	35	0.6	
2720 10022090	BT30 -KH22E -90 ※	2.5 ~ 12.0	90	55	33	35	38	0.5	KH-22E
2720 10022105	-105	2.5 ~ 12.0	105	70	48	35	38	0.6	
2720 10022120	-120	2.5 ~ 12.0	120	85	63	35	38	0.7	
2720 10024090	BT30 -KH24E -90 ※	2.5 ~ 12.0	90	55	33	35	40	0.6	KH-24E
2720 10024105	-105	2.5 ~ 12.0	105	70	48	35	40	0.6	
2720 10024120	-120	2.5 ~ 12.0	120	85	63	35	40	0.7	
2720 10025105	BT30 -KH25E -105 ※	3.5 ~ 16.0	105	70	48	35	44	0.7	KH-25E
2720 10025120	-120 ※	3.5 ~ 16.0	120	85	63	35	44	0.7	
2720 10026105	BT30 -KH26E -105 ※	3.5 ~ 16.0	105	70	48	35	44	0.7	KH-26E
2720 10026120	-120 ※	3.5 ~ 16.0	120	85	63	35	44	0.8	
2720 30016090	BT40 -KH16E -90	2.5 ~ 9.0	90	55	28	35	32	1.1	KH-16E
2720 30016105	-105	2.5 ~ 9.0	105	70	43	35	32	1.2	
2720 30016135	-135	2.5 ~ 9.0	135	100	73	35	32	1.3	
2720 30019090	BT40 -KH19E -90	2.5 ~ 9.0	90	55	28	35	35	1.1	KH-19E
2720 30019105	-105	2.5 ~ 9.0	105	70	43	35	35	1.2	
2720 30019135	-135	2.5 ~ 9.0	135	100	73	35	35	1.4	
2720 30020090	BT40 -KH20E -90	2.5 ~ 9.0	90	55	28	35	35	1.1	KH-20E
2720 30020105	-105	2.5 ~ 9.0	105	70	43	35	35	1.2	
2720 30020135	-135	2.5 ~ 9.0	135	100	73	35	35	1.4	
2720 30022090	BT40 -KH22E -90	2.5 ~ 12.0	90	55	28	35	38	1.1	KH-22E
2720 30022105	-105	2.5 ~ 12.0	105	70	43	35	38	1.1	
2720 30022135	-135	2.5 ~ 12.0	135	100	73	35	38	1.4	
2720 30024105	BT40 -KH24E -105	2.5 ~ 12.0	105	70	43	35	40	1.2	KH-24E
2720 30024135	-135	2.5 ~ 12.0	135	100	73	35	40	1.4	
2720 30025105	BT40 -KH25E -105	3.5 ~ 16.0	105	70	43	35	44	1.2	KH-25E
2720 30025135	-135	3.5 ~ 16.0	135	100	73	35	44	1.5	
2720 30026105	BT40 -KH26E -105	3.5 ~ 16.0	105	70	43	35	44	1.2	KH-26E
2720 30026135	-135	3.5 ~ 16.0	135	100	73	35	44	1.5	
2720 30028105	BT40 -KH28E -105 ※	3.5 ~ 16.0	105	70	43	35	47	1.2	KH-28E
2720 30028135	-135	3.5 ~ 16.0	135	100	73	35	47	1.5	
2720 30030105	BT40 -KH30E -105 ※	3.5 ~ 16.0	105	70	43	35	47	1.4	KH-30E
2720 30030135	-135	3.5 ~ 16.0	135	100	73	35	47	1.4	

Medidas Métricas - Metric Sizes

Unidad : Métrico
Unit : Metric

Código Code	Modelo Model	d	L1	L2	L3	L4	D	kg	Portaherramienta de zanco recto Stub holder
2720 30032135	BT40 -KH32E -135	3.5 ~ 22.0	135	95	68	40	51	1.4	KH-32E
2720 30032165	-165	3.5 ~ 22.0	165	125	98	40	51	1.8	
2720 30035135	BT40 -KH35E -135 ※	3.5 ~ 22.0	135	95	68	40	55		KH-35E
2720 30035165	-165	3.5 ~ 22.0	165	125	98	40	55		
2720 30036135	BT40 -KH36E -135 ※	3.5 ~ 22.0	135	95	68	40	55	1.5	KH-36E
2720 30036165	-165	3.5 ~ 22.0	165	125	98	40	55	1.9	
2720 50016105	BT50 -KH16E -105	2.5 ~ 9.0	105	70	32	35	32	3.8	KH-16E
2720 50016135	-135	2.5 ~ 9.0	135	100	62	35	32	3.8	
2720 50019105	BT50 -KH19E -105	2.5 ~ 9.0	105	70	32	35	35	3.7	KH-19E
2720 50019135	-135	2.5 ~ 9.0	135	100	62	35	35	3.8	
2720 50020105	BT50 -KH20E -105	2.5 ~ 9.0	105	70	32	35	35		KH-20E
2720 50020135	-135	2.5 ~ 9.0	135	100	62	35	35		
2720 50020165	-165	2.5 ~ 9.0	165	130	92	35	35	4.0	
2720 50022105	BT50 -KH22E -105	2.5 ~ 12.0	105	70	32	35	38	3.7	KH-22E
2720 50022135	-135	2.5 ~ 12.0	135	100	62	35	38	3.9	
2720 50022165	-165	2.5 ~ 12.0	165	130	92	35	38	4.2	
2720 50024105	BT50 -KH24E -105	2.5 ~ 12.0	105	70	32	35	40	3.7	KH-24E
2720 50024135	-135	2.5 ~ 12.0	135	100	62	35	40	3.9	
2720 50024165	-165	2.5 ~ 12.0	165	130	92	35	40	4.1	
2720 50025105	BT50 -KH25E -105	3.5 ~ 16.0	105	70	32	35	44	3.7	KH-25E
2720 50025135	-135	3.5 ~ 16.0	135	100	62	35	44	4.0	
2720 50025165	-165	3.5 ~ 16.0	165	130	92	35	44	4.2	
2720 50026105	BT50 -KH26E -105	3.5 ~ 16.0	105	70	32	35	44	3.7	KH-26E
2720 50026135	-135	3.5 ~ 16.0	135	100	62	35	44	3.9	
2720 50026165	-165	3.5 ~ 16.0	165	130	92	35	44	4.4	
2720 50028105	BT50 -KH28E -105	3.5 ~ 16.0	105	70	32	35	47	3.6	KH-28E
2720 50028135	-135	3.5 ~ 16.0	135	100	62	35	47	4.1	
2720 50028165	-165	3.5 ~ 16.0	165	130	92	35	47	4.5	
2720 50030105	BT50 -KH30E -105	3.5 ~ 16.0	105	70	32	35	47	3.6	KH-30E
2720 50030135	-135	3.5 ~ 16.0	135	100	62	35	47	3.9	
2720 50030165	-165	3.5 ~ 16.0	165	130	92	35	47	4.2	
2720 50032135	BT50 -KH32E -135	3.5 ~ 22.0	135	95	57	40	51	3.8	KH-32E
2720 50032165	-165	3.5 ~ 22.0	165	125	87	40	51	4.4	
2720 50035135	BT50 -KH35E -135	3.5 ~ 22.0	135	95	57	40	55	4.0	KH-35E
2720 50035165	-165	3.5 ~ 22.0	165	125	87	40	55	4.5	
2720 50036135	BT50 -KH36E -135	3.5 ~ 22.0	135	95	57	40	55	3.8	KH-36E
2720 50036165	-165	3.5 ~ 22.0	165	125	87	40	55	4.3	
2720 50048135	BT50 -KH48E -135 ※	20.0 ~ 32.0	135	85	47	50	75		KH-48E
2720 50048165	-165 ※	20.0 ~ 32.0	165	115	77	50	75		

1. Los portaherramienta de zanco recto se venden por separado.
2. Para el abastecimiento de refrigerante a través del centro fije una clavija de refrigerante al portaherramienta y use el portaherramienta de zanco recto KH-EC1 o KH-EC2.
3. Las marcas ※ indican que no se pueden usar con el KH-EC1 y el KH-EC2.

1. Stub holders are sold separately.
2. For center through coolant feed, attach a coolant pin to the holder and use with KH-EC1 or KH-EC2 stub holder.
3. ※ marks cannot be used with KH-EC1 and KH-EC2.

Portaherramienta de zanco recto
Stub holder

KH-E Pág. 452
KH-EC1 Pág. 454
KH-EC2 Pág. 455



Clavija de refrigerante
Coolant pin

Pág. 456



Ejemplo para Ordenar - Ordering Example

BT50	-	KH20E	-	105
Interfaz y diámetro de husillo Shank size		Medida del portaherramientas con zanco recto (KH-20E) Stub Holder Size (KH-20E)		Longitud de proyección Projection length (L)

Pulgada a métrico → Pulgada × 25.4
Métrico a pulgada → Métrico ÷ 25.4 ó métrico por 0.03937



Tamaños especiales / personalizados bajo pedido

BT

BT

CAT

AHO

HSK-A/E/F/C

HSK-T

C

UTS

Máquinas Especializadas

Specialized Machine

Equipo Relacionado

Related Equipment

Taladro de Biselado & Casquillo

Bush & Chamfering Drill

167

Keyless Drill Chuck

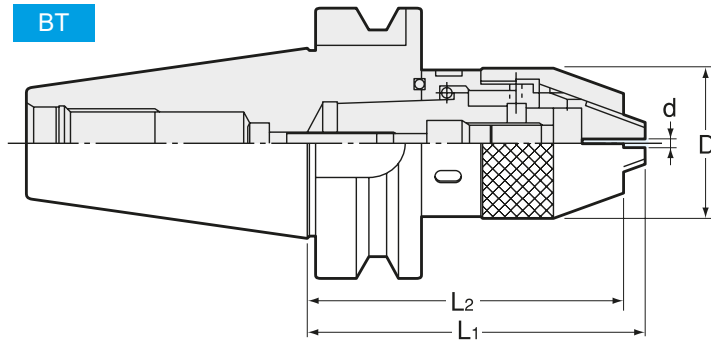

Medidas Métricas - Metric Sizes

Unidad : Métrico
Unit : Metric

Código Code	Modelo Model	d	D	L1	L2	kg	Llave Inglesa Spanner
2680 01065070	BT30 -KLD6.5 -70	0.5 ~ 6.5	34	76	70	1.0	FC6.5LC
2680 01130090	BT30 -KLD13 -90	0.5 ~ 13	50	102	90	1.5	FC13LC
2680 03065075	BT40 -KLD6.5 -75	0.5 ~ 6.5	34	81	75	1.2	FC6.5LC
2680 03065105	-105	0.5 ~ 6.5	34	111	105	1.4	FC6.5LC
2680 03065150	-150	0.5 ~ 6.5	34	156	150	1.6	FC6.5LC
2680 03130095	BT40 -KLD13 -95	0.5 ~ 13	50	107	95	1.7	FC13LC
2680 03130105	-105	0.5 ~ 13	50	117	105	1.9	FC13LC
2680 03130150	-150	0.5 ~ 13	50	162	150	2.5	FC13LC
2680 05065085	BT50 -KLD6.5 -85	0.5 ~ 6.5	34	91	85	3.8	FC6.5LC
2680 05065105	-105	0.5 ~ 6.5	34	111	105	3.9	FC6.5LC
2680 05065150	-150	0.5 ~ 6.5	34	156	150	4.1	FC6.5LC
2680 05130105	BT50 -KLD13 -105	0.5 ~ 13	50	117	105	4.3	FC13LC
2680 05130135	-135	0.5 ~ 13	50	147	135	4.6	FC13LC
2680 05130165	-165	0.5 ~ 13	50	177	165	5.0	FC13LC

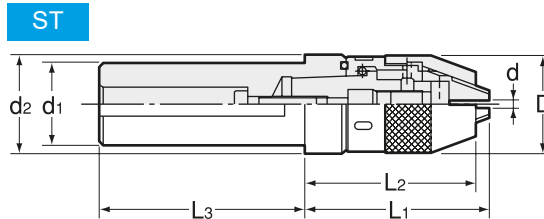

Medidas Métricas - Metric Sizes

Unidad : Métrico
Unit : Metric

Código Code	Modelo Model	d	D	d1	d2	L1	L2	L3	kg	Llave Inglesa Spanner
2684 20065065	ST20 -KLD6.5 -65	0.5 ~ 6.5	34	20	32	84	78	65	0.4	FC6.5LC
2684 25065065	ST25 -KLD6.5 -65	0.5 ~ 6.5	34	25	32	64	58	65	0.5	FC6.5LC
2684 25465065	ST25.4 -KLD6.5 -65	0.5 ~ 6.5	34	25.4	32	64	58	65	0.5	FC6.5LC
2684 32065065	ST32 -KLD6.5 -65	0.5 ~ 6.5	34	32	—	54	48	65	0.7	FC6.5LC
2684 32130065	ST32 -KLD13 -65	0.5 ~ 13	50	32	48	86	74	65	1.2	FC13LC
2684 38065075	ST38.1 -KLD6.5 -75	0.5 ~ 6.5	34	38.1	—	54	48	75	1.0	FC6.5LC
2684 38130075	ST38.1 -KLD13 -75	0.5 ~ 13	50	38.1	48	86	74	75	1.5	FC13LC
2684 40065075	ST40 -KLD6.5 -75	0.5 ~ 6.5	34	40	—	54	48	75	1.0	FC6.5LC
2684 40130075	ST40 -KLD13 -75	0.5 ~ 13	50	40	48	86	74	75	1.5	FC13LC
2684 42065080	ST42 -KLD6.5 -80	0.5 ~ 6.5	34	42	—	54	48	80	1.1	FC6.5LC
2684 42130080	ST42 -KLD13 -80	0.5 ~ 13	50	42	48	86	74	80	1.7	FC13LC
2684 50065085	ST50 -KLD6.5 -85	0.5 ~ 6.5	34	50	—	54	48	85	1.6	FC6.5LC
2684 50130085	ST50 -KLD13 -85	0.5 ~ 13	50	50	—	76	64	85	2.2	FC13LC

Llave Inglesa (Opcional)
Spanner (optional)

Modelo Model	Código Code
FC6.5LC	2685 00000065
FC13LC	2685 00000130

Ejemplo para Ordenar - Ordering Example

BT40 - KLD13 - 105Interfaz y
diámetro de husillo
Shank sizeDiá. Máximo de
sujeción
Max chucking dia.Longitud de
proyección
Projection
length (L)

HP-H

High-speed type

30,000min⁻¹

BT

Hyper Spindle (Speed Inceaser)

- Habilita la operación de corte a alta velocidad al multiplicar la velocidad del husillo de la máquina en los bordes de corte. (Máx 30000 mín⁻¹)
- Enables high speed cutting operation by multiplying the machine spindle speed at the cutting edge. (Max30000min⁻¹)

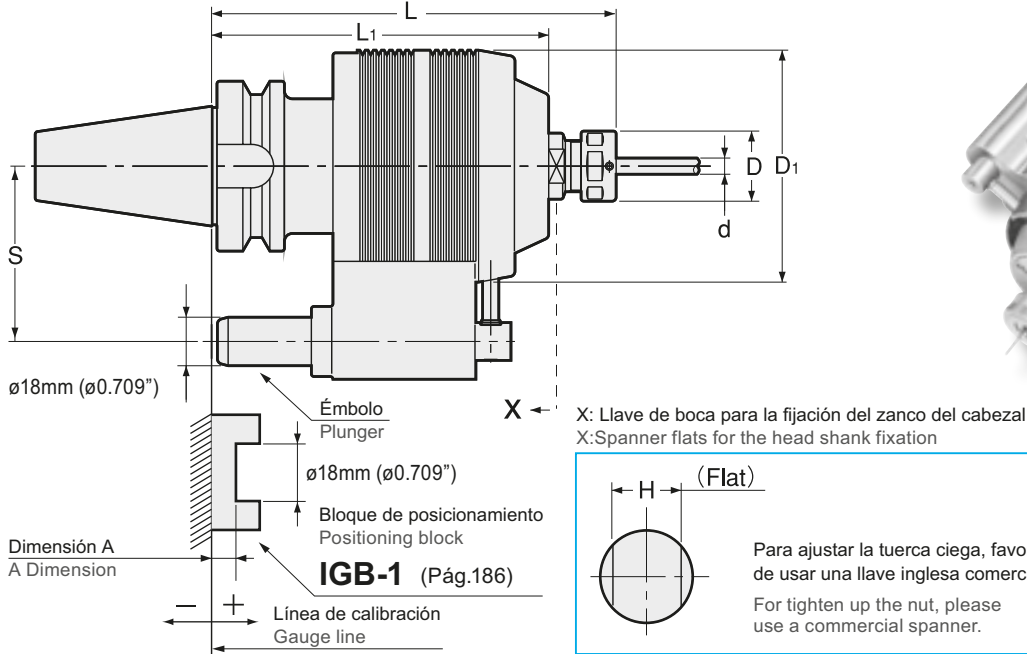

Unidad : Métrico
Unit : Metric

Código Code	Modelo Model	L	S	d	D	D1	L1	Tuerca ciega Nut	H	Incremento de velocidad Speed boost	MAX min ⁻¹	kg
2520 1 ※ 307150	BT40 -HP07H -150 -※	150	65	0.5 ~ 7.0	23	86	125	HDP-07A	16	5	30,000	3.4
2520 1 ※ 307180	-180 -※	180	65	0.5 ~ 7.0	23	86	125	HDP-07A	16	5	30,000	3.5
2520 1 ※ 309150	BT40 -HP09H -150 -※	150	65	2.6 ~ 9.0	26	86	125	HDP-09	21	5	30,000	3.4
2520 1 ※ 309180	-180 -※	180	65	2.6 ~ 9.0	26	86	125	HDP-09	21	5	30,000	3.5
2520 1 ※ 312165	BT40 -HP12H -165 -※	165	65	2.6 ~ 12.0	32	86	125	HDP-12	21	5	30,000	3.5
2520 1 ※ 312180	-180 -※	180	65	2.6 ~ 12.0	32	86	125	HDP-12	21	5	30,000	3.6
2520 1 ※ 507150	BT50 -HP07H -150 -※	150	80	0.5 ~ 7.0	23	86	125	HDP-07A	16	5	30,000	5.9
2520 1 ※ 507180	-180 -※	180	80	0.5 ~ 7.0	23	86	125	HDP-07A	16	5	30,000	6.0
2520 1 ※ 509150	BT50 -HP09H -150 -※	150	80	2.6 ~ 9.0	26	86	125	HDP-09	21	5	30,000	5.9
2520 1 ※ 509180	-180 -※	180	80	2.6 ~ 9.0	26	86	125	HDP-09	21	5	30,000	6.0
2520 1 ※ 512165	BT50 -HP12H -165 -※	165	80	2.6 ~ 12.0	32	86	125	HDP-12	21	5	30,000	6.0
2520 1 ※ 512180	-180 -※	180	80	2.6 ~ 12.0	32	86	125	HDP-12	21	5	30,000	6.0

1. Al hacer su orden, favor de especificar el número de émbolo (No. 1~No.5).
2. El émbolo es ajustable. Favor de dirigirse a la tabla de la derecha.
3. La boquilla y la llave inglesa se venden por separado.
4. Sólo use boquillas de categoría AA.

1. When ordering, please specify the plunger number(No.1~No.5).
2. Plunger is adjustable. Please refer to a chart on the right.
3. Collet and spanner are sold separately.
4. Use AA class collet only.

Tabla del émbolo Plunger table					
Modelo Model	No. de émbolo - Plunger No.A				
	No.1	No.2	No.3	No.4	No.5
Todos los modelos All Model	+24~+15.1	+15~+6.1	+6~-2.9	-3~-11.9	-12~-20.9

Portaherramienta Holder	Boquilla Collet	d	Llave Inglesa Spanner
HP07H	FDC-07AA	0.5 ~ 7.0	S-0
HP09H	FDC-09AA	2.6 ~ 9.0	S-1L
HP12H	FDC-12AA	2.6 ~ 12.0	S-3L



Ejemplo para Ordenar - Ordering Example

BT40	-	HP 07 H	-	150	-	1
Interfaz y diámetro de husillo Shank size		Máx. Diámetro Interno de boquilla Max. collet I.D.		Longitud de proyección Projection length (L)		No. de émbolo Plunger No.

BT
CAT
AHO
HSK-A/E/F/C
HSK-T
C
UTS
Máquinas Especializadas
Specialized Machine
Equipo Relacionado
Related Equipment
Taladro de Biselado & Casquillo
Bush & Chamfering Drill
Milling Chuck
Collet Holder
"R" Zero Holder
Hydraulic Chuck
Shrink Fit
Tapping Chuck
Arbors
Function Holder
Turning Tool
Retention Stud
Tool Shank Dimensions

AH, AH-OH

90°

Angle Heads (Fixed Type)

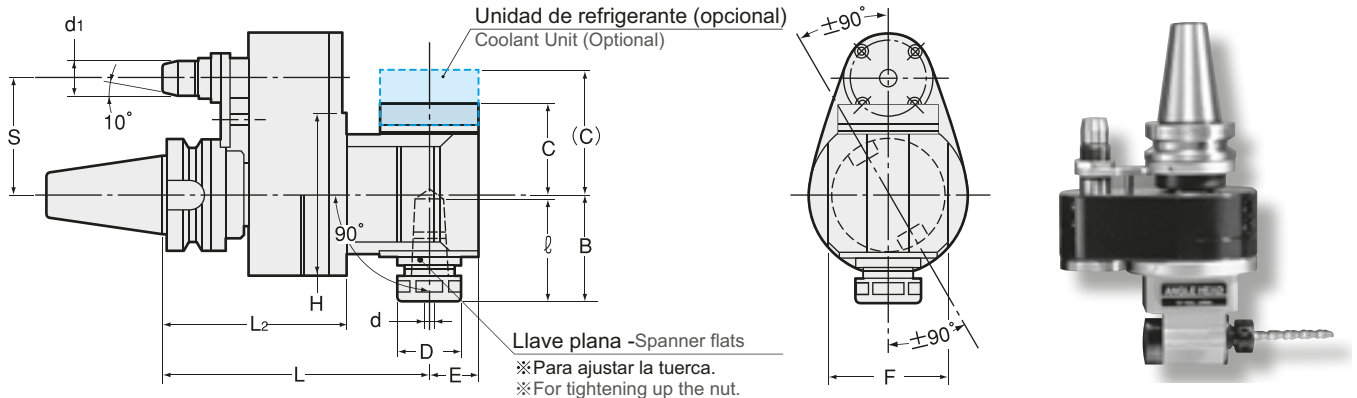

※ Requiere de un bloque de posicionamiento. Favor de consultar la pág. 185-186.

※ Requires a positioning block. Please refer to P.185-186.

Unidad : Métrico
Unit : Metric

	Código Code	Modelo Model	d	L	L2	ℓ	d1	D	B	C (C)	E	F	H	S	kg
Milling Chuck	2760 459000 ※※	BT30 -AH0790 -120-50- ※※	0.5 ~ 7.0	120	75.3	40	13	23	42	33	17	45	78	50	1.8
	2760 469000 ※※	BT30 -AH1290 -125-50- ※※	2.5 ~ 12.0	125	75.3	63.5	13	32	58	44.5	22	47	78	50	2.0
Collet Holder	2760 019000 ※※	BT40 -AH0790 (-AH0790-OH) -150-65- ※※	0.5 ~ 7.0	150	103	40	19.6	23	42	33 (46.5)	17	51	90	65	4.6
	2760 029000 ※※	-180-65- ※※	0.5 ~ 7.0	180	103	40	19.6	23	42	33 (46.5)	17	51	90	65	5.0
"R" Zero Holder	2760 039000 ※※	-210-65- ※※	0.5 ~ 7.0	210	103	40	19.6	23	42	33 (46.5)	17	51	90	65	5.4
	2760 049000 ※※	-240-65- ※※	0.5 ~ 7.0	240	120	40	19.6	23	42	33 (46.5)	17	51	90	65	5.8
Hydraulic Chuck	2760 059000 ※※	-270-65- ※※	0.5 ~ 7.0	270	120	40	19.6	23	42	33 (46.5)	17	51	90	65	6.0
	2760 069000 ※※	BT40 -AH0990 (-AH0990-OH) -150-65- ※※	2.5 ~ 9.0	150	103	55	19.6	26.3	53.5	44.5 (58.5)	22	58	90	65	4.7
Shrink Fit	2760 079000 ※※	-180-65- ※※	2.5 ~ 9.0	180	103	55	19.6	26.3	53.5	44.5 (58.5)	22	58	90	65	5.1
	2760 089000 ※※	-210-65- ※※	2.5 ~ 9.0	210	103	55	19.6	26.3	53.5	44.5 (58.5)	22	58	90	65	5.5
Tapping Chuck	2760 099000 ※※	-240-65- ※※	2.5 ~ 9.0	240	120	55	19.6	26.3	53.5	44.5 (58.5)	22	58	90	65	6.0
	2760 109000 ※※	BT40 -AH1690 (-AH1690-OH) -150-65- ※※	3.5 ~ 16.0	150	103	59	19.6	36.3	59	51 (64.5)	28	67	90	65	4.8
Anchors	2760 119000 ※※	-180-65- ※※	3.5 ~ 16.0	180	103	59	19.6	36.3	59	51 (64.5)	28	67	90	65	5.2
	2760 129000 ※※	-210-65- ※※	3.5 ~ 16.0	210	103	59	19.6	36.3	59	51 (64.5)	28	67	90	65	5.6
Function Holder	2760 139000 ※※	BT50 -AH0790 (-AH0790-OH) -165-80- ※※	0.5 ~ 7.0	165	118	40	28	23	42	33 (46.5)	17	51	90	80	7.6
	2760 149000 ※※	-195-80- ※※	0.5 ~ 7.0	195	118	40	28	23	42	33 (46.5)	17	51	90	80	8.2
Turning Tool	2760 159000 ※※	-225-80- ※※	0.5 ~ 7.0	225	118	40	28	23	42	33 (46.5)	17	51	90	80	8.8
	2760 169000 ※※	-255-80- ※※	0.5 ~ 7.0	255	135	40	28	23	42	33 (46.5)	17	51	90	80	9.4
Retention Stud	2760 179000 ※※	-285-80- ※※	0.5 ~ 7.0	285	135	40	28	23	42	33 (46.5)	17	51	90	80	10.0
	2760 289000 ※※	BT50 -AH0790 (-AH0790-OH) -165-110- ※※	0.5 ~ 7.0	165	118	40	28	23	42	33 (46.5)	17	51	90	110	7.6
Tool Shank Dimensions	2760 299000 ※※	-195-110- ※※	0.5 ~ 7.0	195	118	40	28	23	42	33 (46.5)	17	51	90	110	8.2
	2760 309000 ※※	-225-110- ※※	0.5 ~ 7.0	225	118	40	28	23	42	33 (46.5)	17	51	90	110	8.8
	2760 319000 ※※	-255-110- ※※	0.5 ~ 7.0	255	135	40	28	23	42	33 (46.5)	17	51	90	110	9.4
	2760 329000 ※※	-285-110- ※※	0.5 ~ 7.0	285	135	40	28	23	42	33 (46.5)	17	51	90	110	10.0

Código Code	Modelo Model	d	L	L2	ℓ	d1	D	B	C (C)	E	F	H	S	kg
2760 189000 ※※	BT50 -AH0990 (-AH0990-OH) -165-80- ※※	2.5 ~ 9.0	165	118	55	28	26.3	53.5	44.5 (58.5)	22	58	90	80	7.7
2760 199000 ※※	-195-80- ※※	2.5 ~ 9.0	195	118	55	28	26.3	53.5	44.5 (58.5)	22	58	90	80	8.3
2760 209000 ※※	-225-80- ※※	2.5 ~ 9.0	225	118	55	28	26.3	53.5	44.5 (58.5)	22	58	90	80	8.9
2760 219000 ※※	-255-80- ※※	2.5 ~ 9.0	255	135	55	28	26.3	53.5	44.5 (58.5)	22	58	90	80	9.5
2760 339000 ※※	BT50 -AH0990 (-AH0990-OH) -165-110- ※※	2.5 ~ 9.0	165	118	55	28	26.3	53.5	44.5 (58.5)	22	58	90	110	7.7
2760 349000 ※※	-195-110- ※※	2.5 ~ 9.0	195	118	55	28	26.3	53.5	44.5 (58.5)	22	58	90	110	8.3
2760 359000 ※※	-225-110- ※※	2.5 ~ 9.0	225	118	55	28	26.3	53.5	44.5 (58.5)	22	58	90	110	8.9
2760 369000 ※※	-255-110- ※※	2.5 ~ 9.0	255	135	55	28	26.3	53.5	44.5 (58.5)	22	58	90	110	9.5
2760 229000 ※※	BT50 -AH1690 (-AH1690-OH) -165-80- ※※	3.5 ~ 16.0	165	118	59	28	36.3	59	51 (64.5)	28	67	90	80	7.8
2760 239000 ※※	-195-80- ※※	3.5 ~ 16.0	195	118	59	28	36.3	59	51 (64.5)	28	67	90	80	8.4
2760 249000 ※※	-225-80- ※※	3.5 ~ 16.0	225	118	59	28	36.3	59	51 (64.5)	28	67	90	80	9.0
2760 379000 ※※	BT50 -AH1690 (-AH1690-OH) -165-110- ※※	3.5 ~ 16.0	165	118	59	28	36.3	59	51 (64.5)	28	67	90	110	7.8
2760 389000 ※※	-195-110- ※※	3.5 ~ 16.0	195	118	59	28	36.3	59	51 (64.5)	28	67	90	110	8.4
2760 399000 ※※	-225-110- ※※	3.5 ~ 16.0	225	118	59	28	36.3	59	51 (64.5)	28	67	90	110	9.0
2760 259000 ※※	BT50 -AH2290 (-AH2290-OH) -180-80- ※※	3.5 ~ 22.0	180	117	65	28	46.3	69	57 (70.5)	34.5	75	113	80	9.5
2760 269000 ※※	-210-80- ※※	3.5 ~ 22.0	210	117	65	28	46.3	69	57 (70.5)	34.5	75	113	80	10.3
2760 279000 ※※	-240-80- ※※	3.5 ~ 22.0	240	117	65	28	46.3	69	57 (70.5)	34.5	75	113	80	11.0
2760 409000 ※※	BT50 -AH2290 (-AH2290-OH) -180-110- ※※	3.5 ~ 22.0	180	117	65	28	46.3	69	57 (70.5)	34.5	75	113	110	9.5
2760 419000 ※※	-210-110- ※※	3.5 ~ 22.0	210	117	65	28	46.3	69	57 (70.5)	34.5	75	113	110	10.3
2760 429000 ※※	-240-110- ※※	3.5 ~ 22.0	240	117	65	28	46.3	69	57 (70.5)	34.5	75	113	110	11.0
2760 439000 ※※	BT50 -AH2590 (-AH2590-OH) -195-80- ※※	9.5 ~ 25.0	195	117	101	28	65	90	73 (86.5)	45	90	113	80	15.0
2760 449000 ※※	-195-110- ※※	9.5 ~ 25.0	195	117	101	28	65	90	73 (86.5)	45	90	113	110	15.0

Los nombres de modelos entre corchetes muestran "el tipo de refrigerante" y se cotizan al solicitarlos.

- ※ es para la dimensión A. Favor de dirigirse a la pág. 185.
- Al hacer su orden, favor de especificar la medida del émbolo (dimensión "A").
- El émbolo está fijo (no es ajustable)
- La boquilla y la llave inglesa se venden por separado.
- El BT30-AH1290-125-50- ※※ es sólo para cortes ligeros.

Model names in brackets show "Coolant type", which are quoted on request.

- ※ is for A dimension. Please refer to P. 185.
- When ordering, please specify plunger size ("A" dimension).
- Plunger is fixed (non-adjustable)
- Collet and spanner are sold separately.
- BT30-AH1290-125-50- ※※ is light cutting only.

Accesorios para el cabezal en ángulo del tipo fijo
Accessories for Angle heads fixed type

Modelo Model	Tuerca ciega Nut	Boquilla Collet	Llave inglesa para la tuerca ciega Spanner for nut	Llave de boca para el cabezal Spanner flats for the head
AH0790	HDP-07A	FDC-07A	S-0	Llave inglesa estándar de 14 mm Standard 14mm spanner
AH0990	HDP-09	FDC-09	S-1L	S-1L
AH1290	HDP-12	FDC-12	S-3L	S-3L
AH1690	HDP-16	FDC-16	S-4L	S-4L
AH2290	HDP-22	FDC-22	S-5L	S-5L
AH2590	HPP-25	NTG25	HS2.5-25	HS2.5-25

Boquilla Collet
Pág. 090-093



Llave Inglesa Spanner
Pág. 099



Ejemplo para Ordenar - Ordering Example

BT40	- AH	07	90	- 150	- 65	- 06
Interfaz y diámetro de husillo Shank size		Máx. Diámetro Interno de boquilla Max. collet I.D.	Ángulo Angle	Longitud de proyección Projection length (L)	S	Dimensión A Dimension A

AH, AH-OH

45°

Angle Heads (Fixed Type)

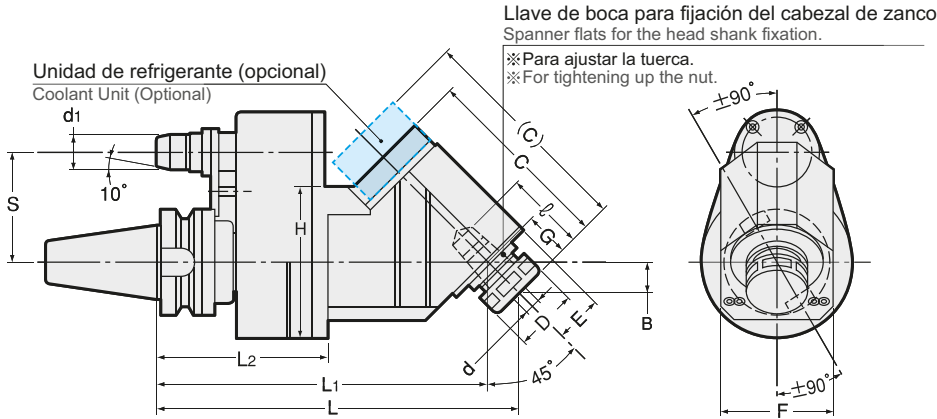

※ Requiere de un bloque de posicionamiento. Favor de consultar la pág. 185-186.
 ※ Requires a positioning block. Please refer to P.185-186.



Unidad : Métrico
Unit : Metric

	Código Code	Modelo Model	d	L	L1	L2	ℓ	d1	D	B	C (C)	E	F	G	H	S	kg
Milling Chuck	2760 014500 ※※	BT40 -AH0745 (-AH0745-OH) -195-65- ※※	0.5 ~ 7.0	195	179.5	103	35	19.6	23	15.6	88.5 (102)	17	51	22	90	65	4.2
	2760 024500 ※※	-215-65- ※※	0.5 ~ 7.0	215	199.5	103	35	19.6	23	15.6	88.5 (102)	17	51	22	90	65	
	2760 034500 ※※	-245-65- ※※	0.5 ~ 7.0	245	229.5	103	35	19.6	23	15.6	88.5 (102)	17	51	22	90	65	
Collet Holder	2760 044500 ※※	BT40 -AH0945 (-AH0945-OH) -205-65- ※※	2.5 ~ 9.0	205	186.5	103	45	19.6	26.3	19.1	104 (118)	22	58	27	90	65	4.5
	2760 054500 ※※	-230-65- ※※	2.5 ~ 9.0	230	211.5	103	45	19.6	26.3	19.1	104 (118)	22	58	27	90	65	
	2760 064500 ※※	-260-65- ※※	2.5 ~ 9.0	260	241.5	103	45	19.6	26.3	19.1	104 (118)	22	58	27	90	65	
"R" Zero Holder	2760 074500 ※※	BT40 -AH1645 (-AH1645-OH) -215-65- ※※	3.5 ~ 16.0	215	197	103	53	19.6	36.3	18.4	113.5 (127)	28	67	26	90	65	5.3
	2760 084500 ※※	-245-65- ※※	3.5 ~ 16.0	245	227	103	53	19.6	36.3	18.4	113.5 (127)	28	67	26	90	65	
Hydraulic Chuck	2760 094500 ※※	BT50 -AH0745 (-AH0745-OH) -210-80- ※※	0.5 ~ 7.0	210	194.5	118	35	28	23	15.6	88.5 (102)	17	51	22	90	80	7.8
	2760 104500 ※※	-230-80- ※※	0.5 ~ 7.0	230	214.5	118	35	28	23	15.6	88.5 (102)	17	51	22	90	80	
Shrink Fit	2760 114500 ※※	-260-80- ※※	0.5 ~ 7.0	260	244.5	118	35	28	23	15.6	88.5 (102)	17	51	22	90	80	
	2760 174500 ※※	BT50 -AH0745 (-AH0745-OH) -210-110- ※※	0.5 ~ 7.0	210	194.5	118	35	28	23	15.6	88.5 (102)	17	51	22	90	110	
Tapping Chuck	2760 184500 ※※	-230-110- ※※	0.5 ~ 7.0	230	214.5	118	35	28	23	15.6	88.5 (102)	17	51	22	90	110	
	2760 194500 ※※	-260-110- ※※	0.5 ~ 7.0	260	244.5	118	35	28	23	15.6	88.5 (102)	17	51	22	90	110	
Aposts	2760 124500 ※※	BT50 -AH0945 (-AH0945-OH) -220-80- ※※	2.5 ~ 9.0	220	201.5	118	45	28	26.3	19.1	104 (118)	22	58	27	90	80	7.8
	2760 134500 ※※	-245-80- ※※	2.5 ~ 9.0	245	226.5	118	45	28	26.3	19.1	104 (118)	22	58	27	90	80	
	2760 144500 ※※	-275-80- ※※	2.5 ~ 9.0	275	256.5	118	45	28	26.3	19.1	104 (118)	22	58	27	90	80	
Function Holder	2760 204500 ※※	BT50 -AH0945 (-AH0945-OH) -220-110- ※※	2.5 ~ 9.0	220	201.5	118	45	28	26.3	19.1	104 (118)	22	58	27	90	110	
	2760 214500 ※※	-245-110- ※※	2.5 ~ 9.0	245	226.5	118	45	28	26.3	19.1	104 (118)	22	58	27	90	110	
Turning Tool	2760 224500 ※※	-275-110- ※※	2.5 ~ 9.0	275	256.5	118	45	28	26.3	19.1	104 (118)	22	58	27	90	110	
	2760 154500 ※※	BT50 -AH1645 (AH1645-OH) -230-80- ※※	3.5 ~ 16.0	230	212	118	53	28	36.3	18.4	113.5 (127)	28	67	26	90	80	
Retention Stud	2760 164500 ※※	-260-80- ※※	3.5 ~ 16.0	260	242	118	53	28	36.3	18.4	113.5 (127)	28	67	26	90	80	
	2760 234500 ※※	BT50 -AH1645 (AH1645-OH) -230-110- ※※	3.5 ~ 16.0	230	212	118	53	28	36.3	18.4	113.5 (127)	28	67	26	90	110	
Tool Shank Dimensions	2760 244500 ※※	-260-110- ※※	3.5 ~ 16.0	260	242	118	53	28	36.3	18.4	113.5 (127)	28	67	26	90	110	

Los nombres de los modelos entre los corchetes muestran "el tipo de refrigerante" y se cotizan al solicitarlos.

- ※ es para la dimensión A. Favor de dirigirse a la pág. 185.
- Al hacer su orden, favor de especificar la medida del émbolo (dimensión "A").
- El émbolo está fijo (no es ajustable)
- La boquilla y la llave inglesa se venden por separado.
- El BT30-AH1290-125-50- ※※ es sólo para cortes ligeros.

Model names in brackets show "Coolant type", which are quoted on request.

- ※ is for A dimension. Please refer to P. 185.
- When ordering, please specify plunger size ("A" dimension).
- Plunger is fixed (non-adjustable)
- Collet and spanner are sold separately.
- BT30-AH1290-125-50- ※※ is light cutting only.

Accesorios para el cabezal en ángulo del tipo fijo Accessories for Angle heads fixed type

Modelo Model	Tuerca ciega Nut	Boquilla Collet	Llave inglesa para la tuerca ciega Spanner for nut	Llave de boca para el cabezal Spanner flats for the head
AH0745	HDP-07A	FDC-07A	S-0	Llave inglesa estándar de 14 mm Standard 14mm spanner
AH0945	HDP-09	FDC-09	S-1L	S-1L
AH1645	HDP-16	FDC-16	S-4L	S-4L

Boquilla Collet

Pág. 090-093



Llave Inglesa Spanner

Pág. 099



Ejemplo para Ordenar - Ordering Example

BT40	- AH	07	45	- 195	- 65	- 06
Interfaz y diámetro de husillo		Máx. Diámetro Interno de boquilla	Ángulo	Longitud de proyección	S	Dimensión A
Shank size		Max. collet I.D.	Angle	Projection length (L)	S	Dimension A

BT

CAT

AHO

HSK-A/E/F/C

HSK-T

C

UTS

Máquinas
Especializadas
Specialized
MachineEquipo
Relacionado
Related
EquipmentTaladro de
Biselado &
Casquillo
Bush &
Chamfering
Drill

Milling Chuck

Collet Holder

"R" Zero Holder

Hydraulic
Chuck

Shrink Fit

Tapping Chuck

Arbors

Function
Holder

Turning Tool

Retention Stud

Tool Shank
Dimensions

AHS, AHL

0-90°

Angle Heads (Flexible Type)

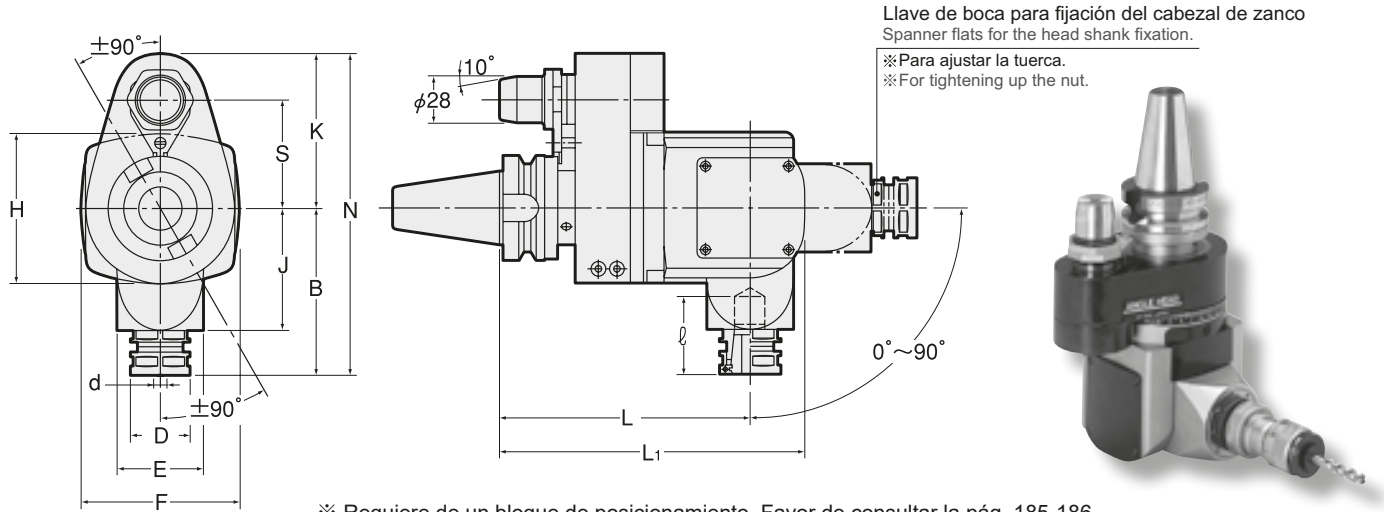

Llave de boca para fijación del cabezal de zanco
Spanner flats for the head shank fixation.

※ Para ajustar la tuerca.
※ For tightening up the nut.

※ Requiere de un bloque de posicionamiento. Favor de consultar la pág. 185-186.
※ Requires a positioning block. Please refer to P.185-186.

Unidad : Métrico
Unit : Metric

Código Code	Modelo Model	d	L	L1	ℓ	D	B	E	F	H	J	K	N	S	kg	Boquilla Collet
2640 010000 ※※	BT40 -AHS07 -150-65- ※※	0.5 ~ 7.0	150	183	65	23	100	52	96	90	73	93	193	65	8.0	FDC-07
2640 020000 ※※	BT40 -AHS09 -150-65- ※※	2.5 ~ 9.0	150	183	65	26	100	52	96	90	73	93	193	65	8.0	FDC-09
2640 030000 ※※	BT40 -AHS16 -150-65- ※※	3.5 ~ 16.0	150	183	47	36	100	52	96	90	73	93	193	65	8.0	FDC-16
2640 040000 ※※	BT50 -AHS07 -165-80- ※※	0.5 ~ 7.0	165	198	65	23	100	52	96	90	73	108	208	80	12.0	FDC-07
2640 050000 ※※	BT50 -AHS09 -165-80- ※※	2.5 ~ 9.0	165	198	65	26	100	52	96	90	73	108	208	80	12.0	FDC-09
2640 060000 ※※	BT50 -AHS16 -165-80- ※※	3.5 ~ 16.0	165	198	47	36	100	52	96	90	73	108	208	80	12.0	FDC-16
2640 070000 ※※	BT50 -AHS07 -165-110- ※※	0.5 ~ 7.0	165	198	65	23	100	52	96	90	73	138	238	110	12.0	FDC-07
2640 080000 ※※	BT50 -AHS09 -165-110- ※※	2.5 ~ 9.0	165	198	65	26	100	52	96	90	73	138	238	110	12.0	FDC-09
2640 090000 ※※	BT50 -AHS16 -165-110- ※※	3.5 ~ 16.0	165	198	47	36	100	52	96	90	73	138	238	110	12.0	FDC-16
2640 100000 ※※	BT50 -AHL16 -165-80- ※※	3.5 ~ 16.0	165	205	70	36	110	66	118	110	78	108	218	80	15.0	FDC-16
2640 110000 ※※	BT50 -AHL22 -165-80- ※※	3.5 ~ 22.0	165	205	65	46	110	66	118	110	78	108	218	80	15.0	FDC-22
2640 120000 ※※	BT50 -AHL16 -165-110- ※※	3.5 ~ 16.0	165	205	70	36	110	66	118	110	78	138	248	110	15.0	FDC-16
2640 130000 ※※	BT50 -AHL22 -165-110- ※※	3.5 ~ 22.0	165	205	65	46	110	66	118	110	78	138	248	110	15.0	FDC-22

- ※ es para la dimensión A. Favor de dirigirse a la pág. 185.
- Al hacer su orden, favor de especificar la medida del émbolo (dimensión "A").
- El émbolo está fijo (no es ajustable)
- La boquilla y la llave inglesa se venden por separado.

- ※ is for A dimension. Please refer to P. 185.
- When ordering, please specify plunger size ("A" dimension)
- Plunger is fixed (non-adjustable)
- Collet and spanner are sold separately.

Ejemplo para Ordenar - Ordering Example

BT40 - AHS 07 - 150 - 65 - 06

Interfaz y
diámetro de husillo

Shank size

Máx. Diámetro Interno de
boquilla

Max. collet I.D.

Longitud de
proyección

Projection
length (L)

S

Dimensión A

S

Dimension A

Boquilla
Collet

Pág. 090-093



Llave Inglesa
Spanner

Pág. 099



Accesorios para el cabezal en ángulo del tipo fijo
Accessories for Angle heads fixed type

Modelo Model	Tuerca ciega Nut	Boquilla Collet	Llave inglesa para la tuerca ciega Spanner for nut	Llave de boca para el cabezal Spanner flats for the head
AHS07	HDP-07A	FDC-07	S-0	Llave inglesa estándar de 14 mm Standard 14mm spanner
AHS09	HDP-09	FDC-09	S-1L	Llave inglesa estándar de 21 mm Standard 21mm spanner
AHS16	HDP-16	FDC-16	S-4L	S-4L
AHL16	HDP-16	FDC-16	S-4L	S-3L
AHL22	HDP-22	FDC-22	S-5L	S-5L

Accesorios para los ANGLE HEADS

Accessories for ANGLE HEADS

BT

BARRA MAESTRA
MASTER BAR

MS



Medidas Métricas - Metric Sizes

Unidad : Métrico
Unit : Metric

Código Code	Modelo Model	D	L	Número de modelo aplicable del Cabezal angular Applicable Angle Head model Number
2767 00007100	AH07-MS7-100	7	100	AH0790, AH0745, AHS07
2767 00009100	AH09-MS16-100	16	100	AH0990, AH0945, AHS09
2767 00016100	AH16-MS16-100	16	100	AH1690, AH1645, AHS16, AHL16
2767 00022100	AH22-MS22-100	22	100	AH2290, AHL22
2767 00025110	AH25-MS25-110	25	110	AH2590

- 1.El cabezal en angular viene completo con un set de Barra maestra. Favor de incluir una Barra maestra extra en su orden en caso de necesitarla.
- 2.Respecto al AH07-MS7-100, la tuerca ciega y Barra maestra están separadas. La Barra maestra y la tuerca ciega se deben poner juntas antes de usarse.
(En cuanto a las medidas, la Barra maestra y la tuerca ciega ya están integradas)

- 1.Angle Head comes complete with a set of Master bar. Please order an extra Master bar in case you need one.
- 2.With regard to AH07-MS7-100, nut and Master bar are separated. Master bar and nut must be put together before use.
(As for other sizes, Master bar and cap nut are already integrated)

Ejemplo para Ordenar - Ordering Example

AH09 - MS16 - 100

Medida de boquilla
Collet size

D L

Aditamento de machueado y cambio rápido (TPC) Quick-change tapping attachment (TPC)

TPC

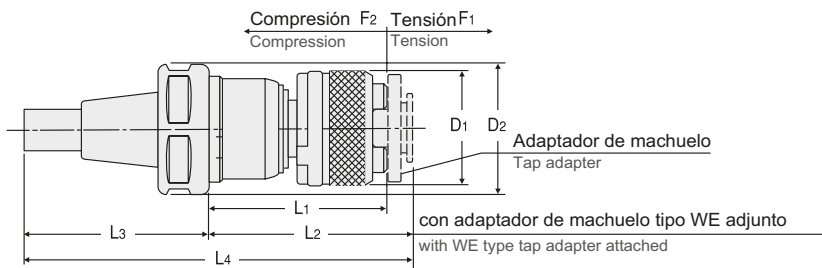

Ejemplo para Ordenar - Ordering Example

TPC22 - 1

Medida del adaptador del machuelo
Tap adapter size

Medidas Métricas - Metric Sizes

Unidad : Métrico
Unit : Metric

Tipo Type	Medida del adaptador de machuelo Tap adapter size	Medida del machuelo (Favor de dirigirse a la pág. 467-468) Tap size (Please refer to P.467-468)	L1	L2	L3	L4	D1	D2	Compensación axial Axial compensation		Número de modelo aplicable del Cabezal angular Applicable Angle Head model Number
									F1	F2	
TPC16-1	1	M3 ~ M12 (M15) U1/4 ~ U7/16 (U9/16) Pipe (PT,PS,PF) 1/8 ~ 1/4	49.5	56.5	64.5	121	32	36	10	2	AH1645, AH1690, AHS16, AHL16
TPC22-1	1	M3 ~ M12 (M15) U1/4 ~ U7/16 (U9/16) Pipe (PT,PS,PF) 1/8 ~ 1/4	49.5	56.5	70	126.5	32	46	10	2	AH2290, AHL22
TPC22-2	2	M8 ~ M22 U3/8 ~ U7/8	69	80	70	150	50	46	10	2	AH2290, AHL22

Pulgada a métrico → Pulgada × 25.4
Métrico a pulgada → Métrico ÷ 25.4 ó métrico por 0.03937



Tamaños especiales / personalizados bajo pedido

BT

CAT

AHO

HSK-A/E/F/C

HSK-T

C

UTS

Máquinas Especializadas

Specialized Machine

Equipo Relacionado

Related Equipment

Taladro de Biselado & Casquillo

Bush & Chamfering Drill

Milling Chuck

Collet Holder

"R" Zero Holder

Hydraulic Chuck

Shrink Fit

Tapping Chuck

Arbors

Function Holder

Turning Tool

Retention Stud

Tool Shank Dimensions

HDC·A-CS

Collet Holder (Coolant Inducer)

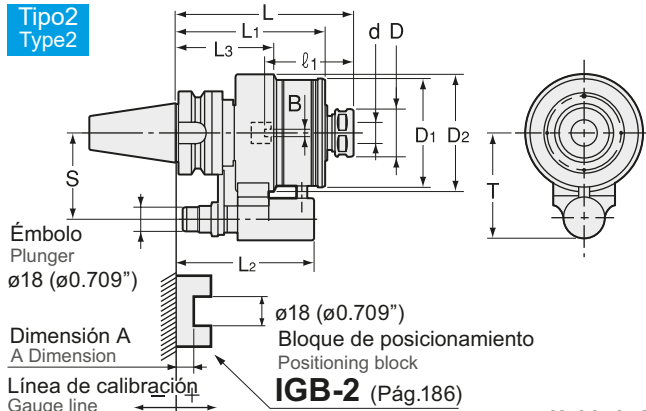
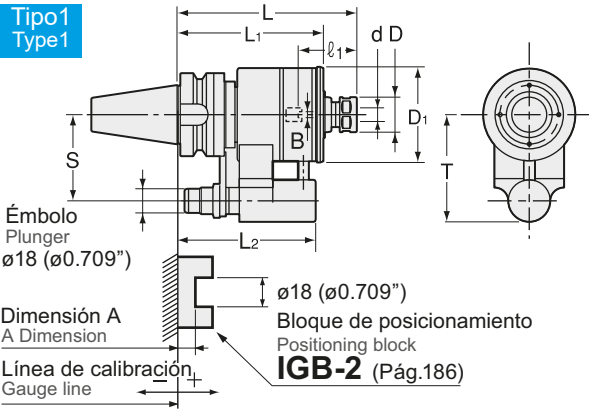

Unidad : Métrico
Unit : Metric

Código Code	Modelo Model	Tipo Type	d	L	B	ℓ1	L1	L2	L3	D	D1	D2	T	S	MAX min ⁻¹	Refrigerante máx Max. Coolant	Unidad de sellado Seal unit	kg
2980 8307135	BT40 -HDC07A -135CS	1	3.0 ~ 7	135	0 ~ 4	22 ~ 48	110	105	—	23	71	—	81	65	8,000	2MPa	CS-1	3.6
2980 8307165	-165CS	1	3.0 ~ 7	165	0 ~ 4	22 ~ 48	110	105	—	23	71	—	81	65	8,000	2MPa	CS-1	3.7
2980 8309135	BT40 -HDC09A -135CS	1	3.0 ~ 9	135	0 ~ 4	27 ~ 48	110	105	—	26	71	—	81	65	8,000	2MPa	CS-1	3.6
2980 8309165	-165CS	1	3.0 ~ 9	165	0 ~ 4	27 ~ 48	110	105	—	26	71	—	81	65	8,000	2MPa	CS-1	3.7
2980 8312135	BT40 -HDC12A -135CS	1	3.0 ~ 12	135	0 ~ 5	33 ~ 46	110	105	—	32	71	—	81	65	8,000	2MPa	CS-1	3.6
2980 8312165	-165CS	1	3.0 ~ 12	165	0 ~ 5	33 ~ 46	110	105	—	32	71	—	81	65	8,000	2MPa	CS-1	3.8
2980 8316135	BT40 -HDC16A -135CS	2	6.0 ~ 16	135	0 ~ 6	38 ~ 66	114	105	75	36	82	89	81	65	6,000	2MPa	CS-2	4.5
2980 8316165	-165CS	2	6.0 ~ 16	165	0 ~ 6	38 ~ 66	114	105	75	36	82	89	81	65	6,000	2MPa	CS-2	4.7
2980 8322150	BT40 -HDC22A -150CS	1	6.0 ~ 22	150	0 ~ 8	47 ~ 103	114	105	—	46	90	—	81	65	5,000	2MPa	CS-3	4.7
2980 8322180	-180CS	1	6.0 ~ 22	180	0 ~ 8	47 ~ 103	114	105	—	46	90	—	81	65	5,000	2MPa	CS-3	5.1
2980 8507150	BT50 -HDC07A -150CS	1	3.0 ~ 7	150	0 ~ 4	22 ~ 48	119	114	—	23	71	—	96	80	8,000	2MPa	CS-1	6.1
2980 8507180	-180CS	1	3.0 ~ 7	180	0 ~ 4	22 ~ 48	119	114	—	23	71	—	96	80	8,000	2MPa	CS-1	6.3
2980 8509150	BT50 -HDC09A -150CS	1	3.0 ~ 9	150	0 ~ 4	27 ~ 48	119	114	—	26	71	—	96	80	8,000	2MPa	CS-1	6.1
2980 8509180	-180CS	1	3.0 ~ 9	180	0 ~ 4	27 ~ 48	119	114	—	26	71	—	96	80	8,000	2MPa	CS-1	6.3
2980 8512150	BT50 -HDC12A -150CS	1	3.0 ~ 12	150	0 ~ 5	33 ~ 46	119	114	—	32	71	—	96	80	8,000	2MPa	CS-1	6.9
2980 8512180	-180CS	1	3.0 ~ 12	180	0 ~ 5	33 ~ 46	119	114	—	32	71	—	96	80	8,000	2MPa	CS-1	7.0
2980 8516150	BT50 -HDC16A -150CS	2	6.0 ~ 16	150	0 ~ 6	38 ~ 66	123	114	84	36	82	89	96	80	6,000	2MPa	CS-2	7.7
2980 8516180	-180CS	2	6.0 ~ 16	180	0 ~ 6	38 ~ 66	123	114	84	36	82	89	96	80	6,000	2MPa	CS-2	8.0
2980 8522150	BT50 -HDC22A -150CS	1	6.0 ~ 22	150	0 ~ 8	47 ~ 103	123	114	—	46	90	—	96	80	5,000	2MPa	CS-3	7.8
2980 8522180	-180CS	1	6.0 ~ 22	180	0 ~ 8	47 ~ 103	123	114	—	46	90	—	96	80	5,000	2MPa	CS-3	8.2

1. La boquilla refrigerante y la llave inglesa se venden por separado.
2. Al hacer su orden, favor de especificar el número de émbolo (No.1~No.5).
3. El émbolo es ajustable. Favor de dirigirse a la tabla de la derecha.
4. Diríjase a la pág. 096 para conocer la longitud mínima de inserción de herramienta en caso de usar su boquilla refrigerante (OH,C).
5. Las dimensiones ℓ 1 entre corchetes son para usar el tornillo de preajuste.
6. El cliente puede reemplazar la unidad de sellado.

1. Coolant collet and spanner are sold separately.
2. When ordering, please specify the plunger number(No.1~No.5).
3. Plunger is adjustable. Please refer to a chart on the right.
4. Refer to P. 096 for minimum tool insertion length in case of using our coolant collets (OH,C).
5. ℓ1 dimensions in brackets are for using preset screw.
6. Seal unit can be replaced by customer.

Ejemplo para Ordenar - Ordering Example

BT40 - HDC 07 A - 135 CS - 1

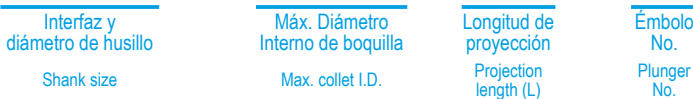

Unidad de sellado Seal unit
Pág. 184

Boquilla Collet
Pág. 090-093

Llave Inglesa Spanner
Pág. 099



Tabla del émbolo Plunger table

Modelo Model	Émbolo No. A Plunger No. A				
	No.1	No.2	No.3	No.4	No.5
BT40	+20 ~ +10.1	+10 ~ +0.1	0 ~ -9.9	-10 ~ -19.9	-20 ~ -29.9
BT50	+28 ~ +18.1	+18 ~ +8.1	+8 ~ -1.9	-2 ~ -11.9	-12 ~ -21.9

Accesorios Accessories

Modelo Model	Tuerca ciega Nut	Boquilla Collet	Llave Inglesa Spanner
HDC07	HDP-07A	FDC-07 (OH or C)	S-0
HDC09	HDP-09	FDC-09 (OH or C)	S-1L
HDC12	HDP-12	FDC-12 (OH or C)	S-3L
HDC16	HDP-16	FDC-16 (OH or C)	S-4L
HDC22	HDP-22	FDC-22 (OH or C)	S-5L

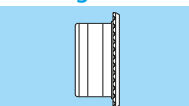
CT·SA-CS

Super Tite-Lock Milling Chuck (Coolant Inducer)

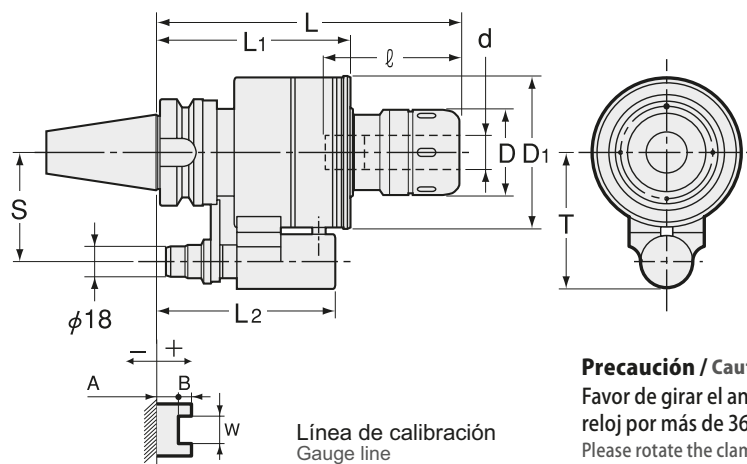

Precaución / Caution

Favor de girar el anillo de sujeción en sentido contrario a las manecillas del reloj por más de 360 grados después de remover una herramienta de corte.
Please rotate the clamping ring counterclockwise more than 360 degrees after a cutting tool is removed.

Código Code	Modelo Model	d	L	ℓ	L1	L2	D	D1	T	S	MAX min ⁻¹	Refrigerante máx. Coolant	Unidad de sellado Seal unit	kg	—	Llave Inglesa Spanner
2980 9316165※	BT40 -CT16SA -165CS-※	16	165	60	114	105	45	90	81	65	5,000	2MPa	CS-3		127,000	HS-1-16
2980 9320180※	-CT20SA -180CS-※	20	180	70	114	105	52	90	81	65	5,000	2MPa	CS-3		127,000	HS-2-20
2980 9325195※	-CT25SA -195CS-※	25	195	75	128	117	61	100	81	65	4,000	2MPa	CS-4	7.0	127,000	HS-2.5-25
2980 9332195※	-CT32SA -195CS-※	32	195	80	128	117	73	100	81	65	4,000	2MPa	CS-4	7.5	132,000	HS-3-32
2980 9516180※	BT50 -CT16SA -180CS-※	16	180	60	123	114	45	90	96	80	5,000	2MPa	CS-3		131,000	HS-1-16
2980 9520180※	-CT20SA -180CS-※	20	180	70	123	114	52	90	96	80	5,000	2MPa	CS-3	8.6	131,000	HS-2-20
2980 9525195※	-CT25SA -195CS-※	25	195	75	125	114	61	100	96	80	4,000	2MPa	CS-4	9.9	131,000	HS-2.5-25
2980 9532195※	-CT32SA -195CS-※	32	195	80	125	114	73	100	96	80	4,000	2MPa	CS-4	10.3	137,000	HS-3-32

- Al hacer su orden, favor de especificar el número de émbolo, o dimensiones de A, B y W.
- A excepción del CT16SA, por favor regresarnos su portaherramienta con función refrigerante mediante su distribuidor autorizado para reemplazar la unidad de sellado.
- Al hacer su orden, indique el número de llaves inglesas que requiere. Las llaves inglesas "son gratuitas" y están limitadas al número de portaherramientas de fresado en su orden.
- No se pueden usar accesorios a excepción de las boquillas MC-C y MC-OH.
- La tolerancia del zanco de las herramientas de corte debe estar dentro de h7.

- When ordering, please specify either plunger number or A, B and W dimensions.
- Except CT16SA, please return your coolant holder to us through your dealer for seal unit replacement.
- When ordering, indicate number of spanners required. "No charge" spanners are limited to number of milling chucks on order.
- Accessories cannot be used except for MC-C and MC-OH.
- Tolerance of cutting tool shank must be h7.

Tabla del émbolo
Plunger table

Modelo Model	Émbolo No. A Plunger No. A				
	No.1	No.2	No.3	No.4	No.5
BT40-CT16S	+20 ~ +10.1	+10 ~ +0.1	0 ~ -9.9	-10 ~ -19.9	-20 ~ -29.9
BT40-CT20S	+20 ~ +10.1	+10 ~ +0.1	0 ~ -9.9	-10 ~ -19.9	-20 ~ -29.9
BT40-CT25S	+33 ~ +23.1	+23 ~ +13.1	+13 ~ +3.1	+3 ~ -6.9	-7 ~ -16.9
BT40-CT32S	+33 ~ +23.1	+23 ~ +13.1	+13 ~ +3.1	+3 ~ -6.9	-7 ~ -16.9
BT50	+28 ~ +18.1	+18 ~ +8.1	+8 ~ -1.9	-2 ~ -11.9	-12 ~ -21.9

Boquilla MC-OH, MC-C Collet Pág. 070-071	Unidad de sellado Seal unit Pág. 184	Llave Inglesa Spanner Pág. 073

Longitud mín de inserción

Min. chucking length

Sin boquilla para refrigerante (MC-C, MC-OH)
Without coolant collet (MC-C, MC-OH)

D.I. del portaherramienta de fresado I.D. of Milling Chuck	Longitud mín de inserción Min. chucking length
16, 20	40
25, 32	50

Con boquilla para refrigerante (MC-C, MC-OH)
With coolant collet (MC-C, MC-OH)

Diámetro Interno de la boquilla Collet I.D.	Longitud mín de inserción Min. chucking length
6, 8	30
10, 12	40
16, 20	45
25	50

Ejemplo para Ordenar - Ordering Example

BT50	- CT 32 SA - 195 CS - 1
Interfaz y diámetro de husillo Shank size	Diámetro Interno I.D. (d)
	Longitud de proyección Projection length (L)
	Émbolo No. Plunger No.

CT•A-CS

Tite-Lock Milling Chuck (Coolant Inducer)

Tipo1
Type1

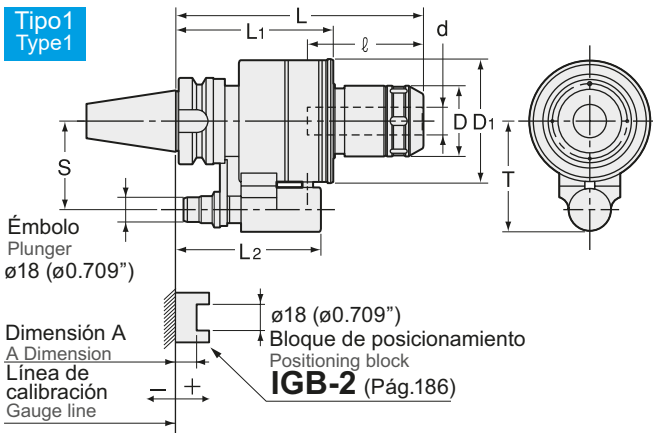

Tipo2
Type2

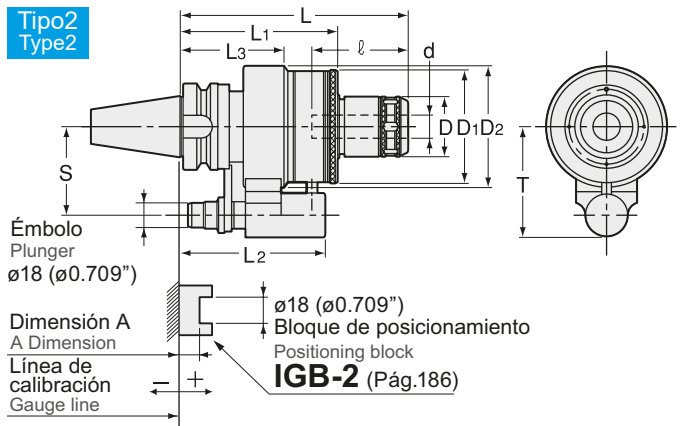

Medidas Métricas - Metric Sizes

Unidad : Métrico
Unit : Metric

Código Code	Modelo Model	Tipo Type	d	L	ℓ	L1	L2	L3	D	D1	D2	T	S	MAX min ⁻¹	Refrigerante máx Max. Coolant	kg	Llave Inglesa Spanner
2980 2316165 ※	BT40 -CT16A -165CS- ※	2	16	165	60	114	105	75	45	82	89	81	65	6,000	2MPa	4.9	HS-1-16
2980 2320180 ※	BT40 -CT20A -180CS- ※	1	20	180	70	114	105	—	52	90	—	81	65	5,000	2MPa	5.5	HS-2-20
2980 2325180 ※	BT40 -CT25A -180CS- ※	1	25	180	75	114	105	—	61	90	—	81	65	5,000	2MPa	5.7	HS-2.5-25
2980 2332195 ※	BT40 -CT32A -195CS- ※	1	32	195	80	128	117	—	73	100	—	81	65	4,000	2MPa	7.3	HS-3-32
2980 2516180 ※	BT50 -CT16A -180CS- ※	2	16	180	60	123	114	84	45	82	89	96	80	6,000	2MPa	7.7	HS-1-16
2980 2520195 ※	BT50 -CT20A -195CS- ※	1	20	195	70	123	114	—	52	90	—	96	80	5,000	2MPa	8.8	HS-2-20
2980 2525195 ※	BT50 -CT25A -195CS- ※	1	25	195	80	123	114	—	61	90	—	96	80	5,000	2MPa	9.5	HS-2.5-25
2980 2532195 ※	BT50 -CT32A -195CS- ※	1	32	195	80	125	114	—	73	100	—	96	80	4,000	2MPa	10.2	HS-3-32

- Al hacer su orden, favor de especificar el número de émbolo (No. 1~No.5).
- El émbolo es ajustable. Favor de dirigirse a la tabla de la derecha.
- Favor de regresarnos su portaherramienta de refrigerante a través de su distribuidor autorizado para reemplazar la unidad de sellado.
- Al hacer su orden, indique el número de llaves inglesas que requiere. Las llaves inglesas "son gratuitas" y están limitadas al número de portaherramienta de fresado en su orden.
- Los accesorios no se pueden usar a excepción de las boquillas para MC-C y MC-OH.
- La tolerancia del zanco de la herramienta de corte debe estar dentro de h7.

- When ordering, please specify the plunger number(No.1~No.5).
- Plunger is adjustable. Please refer to a chart on the right.
- Please return your coolant holder to us through your dealer for seal unit replacement.
- When ordering, indicate number of spanners required. "No charge" spanners are limited to number of milling chucks on order.
- Accessories cannot be used except for MC-C and MC-OH.
- Tolerance of cutting tool shank must be h7.

Longitud mín de inserción Min. chucking length

Sin boquilla para refrigerante (MC-C, MC-OH)
Without coolant collet (MC-C, MC-OH)

D.I. del portaherramienta de fresado I.D. of Milling Chuck	Longitud mín de inserción Min. chucking length
16	40
20, 25	45
32	60

Con boquilla para refrigerante (MC-C, MC-OH)
With coolant collet (MC-C, MC-OH)

Diámetro Interno de la boquilla Collet I.D.	Longitud mín de inserción Min. chucking length
6, 8	30
10, 12	40
16, 20	45
25	55

Tabla del émbolo Plunger table

Modelo Model	Émbolo No. A Plunger No. A				
	No.1	No.2	No.3	No.4	No.5
BT40-CT16A	+20 ~ +10.1	+10 ~ +0.1	0 ~ -9.9	-10 ~ -19.9	-20 ~ -29.9
BT40-CT20A	+20 ~ +10.1	+10 ~ +0.1	0 ~ -9.9	-10 ~ -19.9	-20 ~ -29.9
BT40-CT25A	+20 ~ +10.1	+10 ~ +0.1	0 ~ -9.9	-10 ~ -19.9	-20 ~ -29.9
BT40-CT32A	+33 ~ +23.1	+23 ~ +13.1	+13 ~ +3.1	+3 ~ -6.9	-7 ~ -16.9
BT50	+28 ~ +18.1	+18 ~ +8.1	+8 ~ -1.9	-2 ~ -11.9	-12 ~ -21.9

Ejemplo para Ordenar - Ordering Example

BT50	-	CT 32	A	-	195 CS	-	1
Interfaz y diámetro de husillo Shank size		Diámetro Interno I.D. (d)		Longitud de proyección Projection length (L)		Émbolo No. Plunger No.	

Boquilla
MC-OH.MC-C Collet
Pág. 070-071

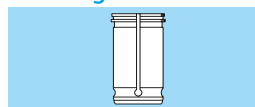

Llave Inglesa
Spanner
Pág. 073



HC-CS

Hydraulic Chuck (Coolant Inducer)

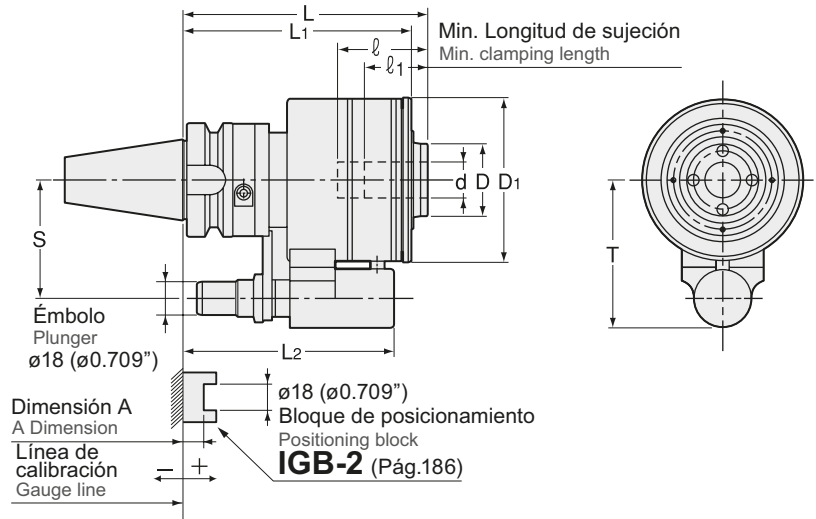

Medidas Métricas - Metric Sizes

Unidad : Métrico
Unit : Metric

Código Code	Modelo Model	d	L	L1	L2	D	D1	ℓ	ℓ1	T	S	MAX min ⁻¹	Refrigerante máx Max. Coolant	Unidad de sellado Seal unit	kg	Llave Allen (Opcional) Hex. Wrench (Optional)
2980 3316135 ※	BT40 -HC16 -135CS- ※	16	135	126	117	41	90	50	40	81	65	5,000	2MPa	CS-3	5.0	L-4T
2980 3320135 ※	BT40 -HC20 -135CS- ※	20	135	126	117	45	90	50	40	81	65	5,000	2MPa	CS-3	5.0	
2980 3325135 ※	BT40 -HC25 -135CS- ※	25	135	130	118	50	100	60	50	81	65	4,000	2MPa	CS-4	5.7	
2980 3516150 ※	BT50 -HC16 -150CS- ※	16	150	135	126	42	90	50	40	96	80	5,000	2MPa	CS-3	8.1	L-4T
2980 3520150 ※	BT50 -HC20 -150CS- ※	20	150	135	126	46	90	50	40	96	80	5,000	2MPa	CS-3	8.8	
2980 3525150 ※	BT50 -HC25 -150CS- ※	25	150	139	128	52	100	60	50	96	80	4,000	2MPa	CS-4	9.4	

- Al hacer su orden, favor de especificar el número de émbolo (No. 1~No.5).
- El émbolo es ajustable. Favor de dirigirse a una tabla a la derecha.
- Favor de usar la herramienta de corte en un rango de tolerancia menor al de h7. Rango de tolerancia dentro de $_{-0.01}^{0}$. Se sugiere en caso de que sean herramientas de corte nuevas.
- Nunca opere el perno de sujeción si la herramienta de corte no está en el portaherramienta, de otro modo el portaherramienta se dañará.
- El cliente puede reemplazar la unidad de sellado.

- When ordering, please specify the plunger number(No.1~No.5).
- Plunger is adjustable. Please refer to a chart on the right.
- Please use cutting tool with smaller tolerance than h7. Tolerance within $_{-0.01}^{0}$ is recommended in case newly making cutting tools.
- Never operate clamp bolt without cutting tool in the chuck, otherwise the chuck will be damaged.
- Seal unit can be replaced by customer.

Unidad de sellado
Seal unit

Pág. 184

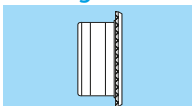

Llave Allen
Hex. Wrench

Pág. 099



Modelo Model	Tabla del émbolo Plunger table				
	Émbolo No. A Plunger No. A				
	No.1	No.2	No.3	No.4	No.5
BT40-HC16	+32 ~ +22.1	+22 ~ +12.1	+12 ~ +2.1	+2 ~ -7.9	-8 ~ -17.9
BT40-HC20	+32 ~ +22.1	+22 ~ +12.1	+12 ~ +2.1	+2 ~ -7.9	-8 ~ -17.9
BT40-HC25	+34 ~ +24.1	+24 ~ +14.1	+14 ~ +4.1	+4 ~ -5.9	-6 ~ -15.1
BT50-HC16	+40 ~ +30.1	+30 ~ +20.1	+20 ~ +10.1	+10 ~ +0.1	0 ~ -9.9
BT50-HC20	+40 ~ +30.1	+30 ~ +20.1	+20 ~ +10.1	+10 ~ +0.1	0 ~ -9.9
BT50-HC25	+42 ~ +32.1	+32 ~ +22.1	+22 ~ +12.1	+12 ~ +2.1	+2 ~ -7.9

Ejemplo para Ordenar - Ordering Example

BT40	-	HC 16	S	-	135	CS	-	1
Interfaz y diámetro de husillo Shank size		Diámetro Interno I.D. (d)		Longitud de proyección Projection length (L)		Émbolo No. Plunger No.		

TP-CS

Tapping Chuck (Coolant Inducer)

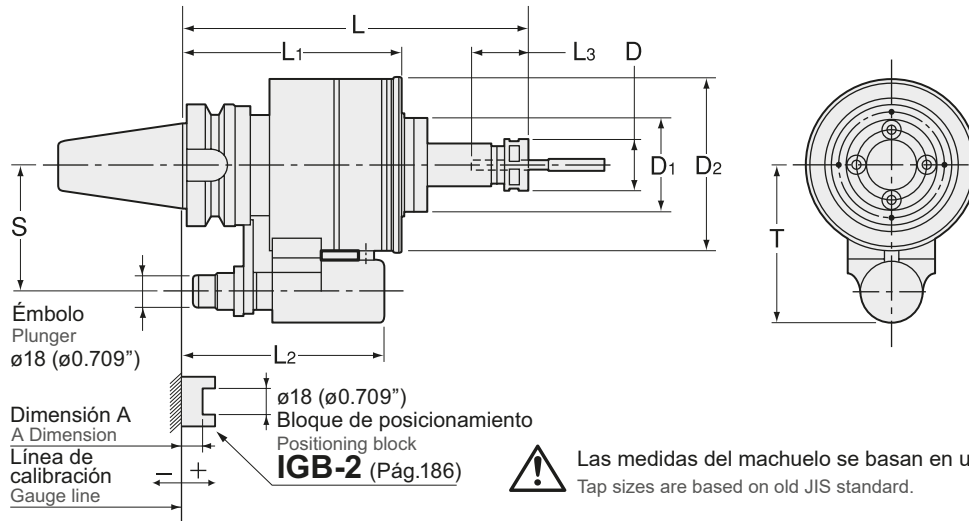

Las medidas del machuelo se basan en un estándar JIS antiguo.
Tap sizes are based on old JIS standard.

Medidas Métricas - Metric Sizes

Unidad : Métrico
Unit : Metric

Código Code	Modelo Model	Medida de machuelo Tap size	L	L1	L2	L3±3	D	Compresión Compression	Tensión Tension	D1	D2	T	S	MAX min ⁻¹	Refrigerante máx Max. Coolant	Unidad de sellado Seal unit	kg
2980 6309180 ※	BT40 -TP09 -180CS- ※	M6 ~ M10	180	114	105	26	26	0.5	20	48	90	81	65	5,000	2MPa	CS-3	4.9
2980 6312195 ※	BT40 -TP12 -195CS- ※	M6 ~ M10	195	114	105	35	32	0.5	20	48	90	81	65	5,000	2MPa	CS-3	4.5
2980 6312195 ※	-195CS- ※	M12 ~ M14	195	114	105	40	32	0.5	20	48	90	81	65	5,000	2MPa	CS-3	4.5
2980 6316210 ※	BT40 -TP16 -210CS- ※	M12 ~ M14	210	128	117	40	36	0.5	20	58	100	81	65	4,000	2MPa	CS-4	5.0
2980 6316210 ※	-210CS- ※	M16 ~ M18	210	128	117	47	36	0.5	20	58	100	81	65	4,000	2MPa	CS-4	5.0
2980 6322225 ※	BT40 -TP22 -225CS- ※	M16 ~ M20	225	128	117	47	46	0.5	20	58	100	81	65	4,000	2MPa	CS-4	6.5
2980 6322225 ※	-225CS- ※	M22 ~ M27	225	128	117	53	46	0.5	20	58	100	81	65	4,000	2MPa	CS-4	6.5
2980 6509195 ※	BT50 -TP09 -195CS- ※	M6 ~ M10	195	123	114	26	26	0.5	20	48	90	96	80	5,000	2MPa	CS-3	7.8
2980 6512210 ※	BT50 -TP12 -210CS- ※	M6 ~ M10	210	123	114	35	32	0.5	20	48	90	96	80	5,000	2MPa	CS-3	8.2
2980 6512210 ※	-210CS- ※	M12 ~ M14	210	123	114	40	32	0.5	20	48	90	96	80	5,000	2MPa	CS-3	8.2
2980 6516210 ※	BT50 -TP16 -210CS- ※	M12 ~ M14	210	125	114	40	36	0.5	20	58	100	96	80	4,000	2MPa	CS-4	8.3
2980 6516210 ※	-210CS- ※	M16 ~ M18	210	125	114	47	36	0.5	20	58	100	96	80	4,000	2MPa	CS-4	8.3
2980 6522225 ※	BT50 -TP22 -225CS- ※	M16 ~ M20	225	125	114	47	46	0.5	20	58	100	96	80	4,000	2MPa	CS-4	8.5
2980 6522225 ※	-225CS- ※	M22 ~ M27	225	125	114	53	46	0.5	20	58	100	96	80	4,000	2MPa	CS-4	8.5

- Al hacer su orden, favor de especificar el número de émbolo (No. 1~No.5).
- El émbolo es ajustable. Favor de dirigirse a la tabla en la parte de abajo.
- La unidad de preajuste, la boquilla refrigerante y la llave inglesa se venden por separado.
- El cliente puede reemplazar la unidad de sellado.

- When ordering, please specify the plunger number(No.1~No.5).
- Plunger is adjustable. Please refer to a chart below.
- Preset driver, coolant collet and spanner are sold separately.
- Seal unit can be replaced by customer.

Accesorios Accessories

Modelo Model	Unidad preajustada Preset driver	Medida de machuelo Tap size	Boquilla Collet	Llave Inglesa Spanner
TP09	CTPS09- ※	M6 ~ M10	FDC-09 (OH or C)	S-1L
TP12	CTPS12- ※	M6 ~ M14	FDC-12 (OH or C)	S-3L
TP16	CTPS16- ※	M12 ~ M18	FDC-16 (OH or C)	S-4L
TP22	CTPS22- ※	M16 ~ M27	FDC-22 (OH or C)	S-5L

Unidad de sellado Seal unit

Pág. 184

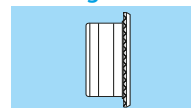

- Por favor especificar la medida del machuelo.
- Por favor referirse a la medida del machuelo para el diámetro interno de la boquilla.
 - Please specify tap size.
 - Please refer to tap size for I.D. of collet.

Medida de machuelo (JIS antiguo)
Tap size (Old JIS)

Rosca métrica Metric Thread	Rosca unificada Unified Thread	Rosca Whitworth Whitworth Thread	Diá. del zanco de herramientas Shank Dia. φ	Cuadro Square □
M6	U1/4	W1/4	6	4.5
	U5/16	W5/16	6.1	5
M7 M8			6.2	5
M9 M10	U3/8	W3/8	7	5.5
M11	U7/16	W7/16	8	6
M12			8.5	6.5
	U1/2	W1/2	9	7
M14 M15	U9/16	W9/16	10.5	8
	U5/8	W5/8	12	9
M16			12.5	10
M17			13	10
M18	U3/4	W3/4	14	11
M20			15	12
M22	U7/8	W7/8	17	13

Tabla del émbolo
Plunger table

Modelo Model	Émbolo No. A Plunger No. A				
	No.1	No.2	No.3	No.4	No.5
BT40-TP09	+20 ~ +10.1	+10 ~ +0.1	0 ~ -9.9	-10 ~ -19.9	+20 ~ -29.9
BT40-TP12	+20 ~ +10.1	+10 ~ +0.1	0 ~ -9.9	-10 ~ -19.9	+20 ~ -29.9
BT40-TP16	+33 ~ +23.1	+23 ~ +13.1	+13 ~ +3.1	+3 ~ -6.9	-7 ~ -16.9
BT40-TP22	+33 ~ +23.1	+23 ~ +13.1	+13 ~ +3.1	+3 ~ -6.9	-7 ~ -16.9
BT50	+28 ~ +18.1	+18 ~ +8.1	+8 ~ -1.9	-2 ~ -11.9	-12 ~ -21.9

Ejemplo para Ordenar - Ordering Example

BT40	- TP	09	- 180	CS	- 1
Interfaz y diámetro de husillo Shank size	Medida Size	Longitud de proyección Projection length (L)	Émbolo No. Plunger No.		

MT-CS

Morse Taper Holder (Coolant Inducer)

Tipo1
Type1

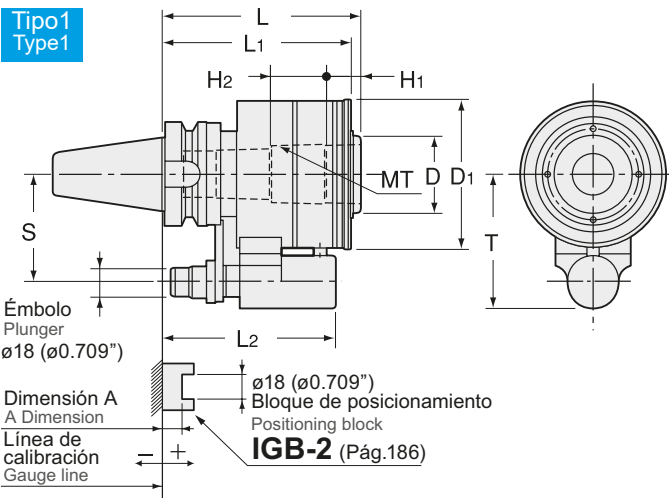

Tipo2
Type2

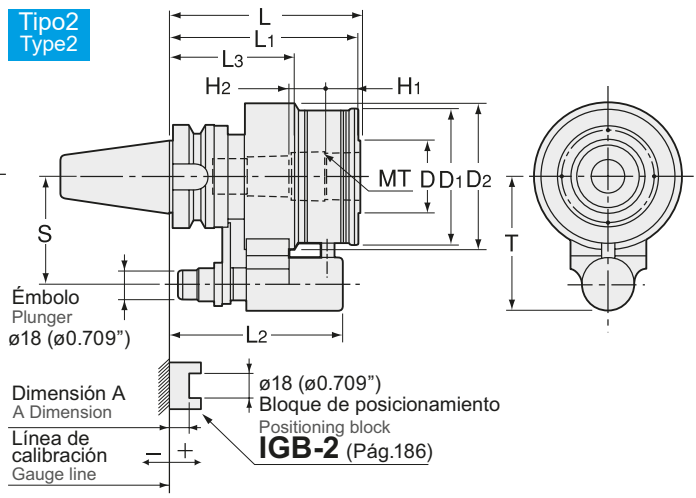

Medidas Métricas - Metric Sizes

Unidad : Métrico
Unit : Metric

Código Code	Modelo Model	Tipo Type	Medida MT size MT	L	L1	L2	L3	D	D1	D2	T	H1	H2	S	MAX min ⁻¹	Refrigerante máx. Coolant	Unidad de sellado Seal unit	kg
2980 1303115 ※	BT40 -MT3 -115CS- ※	2	3	115	114	105	75	45	82	89	81	21	22	65	6,000	2MPa	CS-2	3.3
2980 1304120 ※	BT40 -MT4 -120CS- ※	1	4	120	114	105	—	48	90	—	81	21	34	65	5,000	2MPa	CS-3	3.4
2980 1503125 ※	BT50 -MT3 -125CS- ※	2	3	125	123	114	84	45	82	89	96	21	22	80	6,000	2MPa	CS-2	6.4
2980 1504135 ※	BT50 -MT4 -135CS- ※	1	4	135	123	114	—	48	90	—	96	21	34	80	5,000	2MPa	CS-3	6.8
2980 1505135 ※	BT50 -MT5 -135CS- ※	1	5	135	125	114	—	58	100	—	96	28	40	80	4,000	2MPa	CS-4	7.2

1. Al hacer su orden, favor de especificar el número de émbolo (No. 1~No.5).
2. El émbolo es ajustable. Favor de dirigirse a la tabla de la derecha.
3. El cliente puede reemplazar la unidad de sellado.

1. When ordering, please specify the plunger number(No.1~No.5).
2. Plunger is adjustable. Please refer to a chart on the right.
3. Seal unit can be replaced by customer.

Tabla del émbolo
Plunger table

Modelo Model	Émbolo No. A Plunger No. A				
	No.1	No.2	No.3	No.4	No.5
BT40	+20 ~ +10.1	+10 ~ +0.1	0 ~ -9.9	-10 ~ -19.9	-20 ~ -29.9
BT50	+28 ~ +18.1	+18 ~ +8.1	+8 ~ -1.9	-2 ~ -11.9	-12 ~ -21.9

Unidad de sellado
Seal unit

Pág. 184

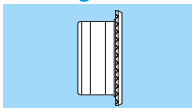

Ejemplo para Ordenar - Ordering Example

BT50	- MT4	- 120	CS	- 1
Interfaz y diámetro de husillo Shank size	Medida MT Size MT	Longitud de proyección Projection length (L)	Émbolo No. Plunger No.	

Manga reductora para CMT - Reduction sleeve for CMT

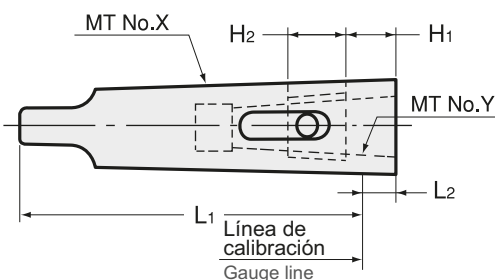

Código Code	Modelo Model	MT No.X	MT No.Y	L1	L2	H1	H2	kg
2504 11000031	CMT3 -1	3	1	94	5	13	15	0.3
2504 11000032	-2	3	2	94	15	17	20	0.3
2504 11000041	CMT4 -1	4	1	117.5	4.5	13	15	0.6
2504 11000042	-2	4	2	117.5	6.5	17	20	0.6
2504 11000043	-3	4	3	117.5	22.5	21	22	0.7
2504 11000052	CMT5 -2	5	2	149.5	0.5	17	20	1.4
2504 11000053	-3	5	3	149.5	2.5	21	22	1.3
2504 11000054	-4	5	4	149.5	15.5	21	34	1.3

SL-CS

Side Lock Holder (Coolant Inducer)

Tipo1
Type1

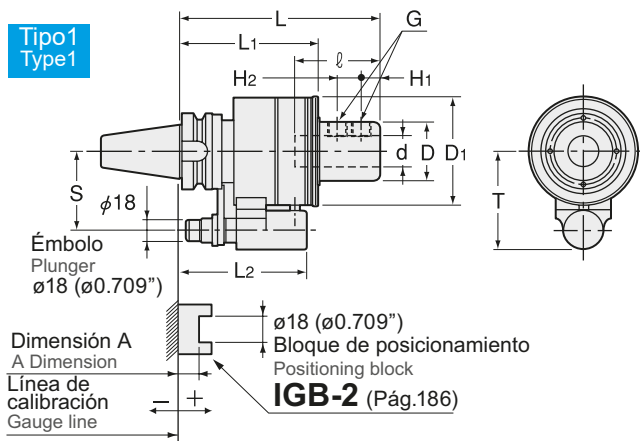

Tipo2
Type2

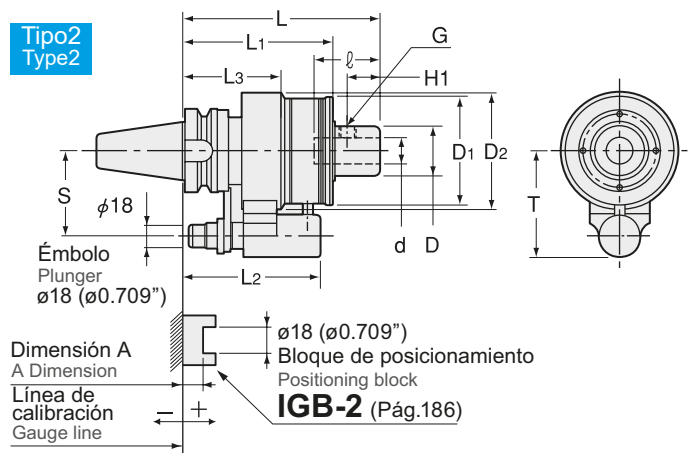

Medidas Métricas - Metric Sizes

Unidad : Métrico
Unit : Metric

Código Code	Modelo Model	Tipo Type	d	L	L1	D	D1	D2	ℓ	L2	L3	T	H1	H2	G	S	MAX min ⁻¹	Refrigerante máx Max. Coolant	Unidad de sellado Seal unit	kg
2980 0316150 ※	BT40 -SL16 -150CS- ※	2	16	150	114	38	82	89	48	105	75	81	25	—	M12	65	6,000	2MPa	CS-2	4.7
2980 0320150 ※	BT40 -SL20 -150CS- ※	2	20	150	114	38	82	89	50	105	75	81	25	—	M12	65	6,000	2MPa	CS-2	4.7
2980 0325165 ※	BT40 -SL25 -165CS- ※	1	25	165	114	48	90	—	56	105	—	81	15	20	M16	65	5,000	2MPa	CS-3	5.2
2980 0332180 ※	BT40 -SL32 -180CS- ※	1	32	180	128	58	100	—	60	117	—	81	15	20	M16	65	4,000	2MPa	CS-4	6.5
2980 0516165 ※	BT50 -SL16 -165CS- ※	2	16	165	123	38	82	89	48	114	84	96	25	—	M12	80	6,000	2MPa	CS-2	8.0
2980 0520165 ※	BT50 -SL20 -165CS- ※	2	20	165	123	38	82	89	50	114	84	96	25	—	M12	80	6,000	2MPa	CS-2	7.9
2980 0525180 ※	BT50 -SL25 -180CS- ※	1	25	180	123	48	90	—	56	114	—	96	15	20	M16	80	5,000	2MPa	CS-3	8.5
2980 0532180 ※	BT50 -SL32 -180CS- ※	1	32	180	125	58	100	—	60	114	—	96	15	20	M16	80	4,000	2MPa	CS-4	9.4
2980 0540180 ※	BT50 -SL40 -180CS- ※	1	40	180	125	90	100	—	70	114	—	96	15	25	M16	80	4,000	2MPa	-	10.6

- Al hacer su orden, favor de especificar el número de émbolo (No. 1~No.5).
- El émbolo es ajustable. Favor de dirigirse a la tabla de la derecha.
- Favor de regresarnos su portaherramienta con función de refrigerante (sólo el BT50-SL40) a través de su distribuidor autorizado para reemplazar la unidad de sellado.

- When ordering, please specify the plunger number(No.1~No.5).
- Plunger is adjustable. Please refer to a chart on the right.
- Please return your coolant holder (BT50-SL40 only) to us through your dealer for seal unit replacement.

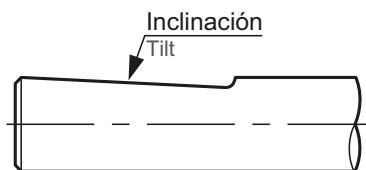

Por favor contactar a nuestro personal de ingeniería si el zanco de la herramienta de corte esta inclinado.
Please contact our engineering staff if flats are tilted.

Tabla del émbolo Plunger table

Modelo Model	Émbolo No. A Plunger No. A				
	No.1	No.2	No.3	No.4	No.5
BT40-SL16	+20 ~ +10.1	+10 ~ +0.1	0 ~ -9.9	-10 ~ -19.9	-20 ~ -29.9
BT40-SL20	+20 ~ +10.1	+10 ~ +0.1	0 ~ -9.9	-10 ~ -19.9	-20 ~ -29.9
BT40-SL25	+20 ~ +10.1	+10 ~ +0.1	0 ~ -9.9	-10 ~ -19.9	-20 ~ -29.9
BT40-SL32	+33 ~ +23.1	+23 ~ +13.1	+13 ~ +3.1	+3 ~ -6.9	-7 ~ -16.9
BT50	+28 ~ +18.1	+18 ~ +8.1	+8 ~ -1.9	-2 ~ -11.9	-12 ~ -21.9

Ejemplo para Ordenar - Ordering Example

BT50	- SL	16	- 165	CS	- 1
Interfaz y diámetro de husillo Shank size		Diámetro Interno I.D. (d)	Longitud de proyección Projection length (L)		Émbolo No. Plunger No.

Manga reductora para CSL - Reduction sleeve for CSL

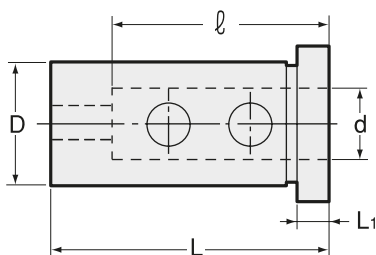

Código Code	Modelo Model	d	D	ℓ	L	L1	kg
2504 01002016	CSL20 -16	16	20	48	55.5	5.5	0.1
2504 01002516	CSL25 -16	16	25	48	61.5	5.5	0.2
2504 01002520	CSL25 -20	20	25	50	61.5	5.5	0.2
2504 01003216	CSL32 -16	16	32	48	65.5	5.5	0.3
2504 01003220	CSL32 -20	20	32	50	65.5	5.5	0.3
2504 01003225	CSL32 -25	25	32	56	65.5	5.5	0.2
2504 01004016	CSL40 -16	16	40	48	75.5	5.5	0.7
2504 01004020	CSL40 -20	20	40	50	75.5	5.5	0.7
2504 01004025	CSL40 -25	25	40	56	75.5	5.5	0.6
2504 01004032	CSL40 -32	32	40	60	75.5	5.5	0.6

Pulgada a métrico → Pulgada × 25.4
Métrico a pulgada → Métrico ÷ 25.4 ó métrico por 0.03937



Tamaños especiales / personalizados bajo pedido

BT

BT

CAT

AHO

HSK-A/E/F/C

HSK-T

C

UTS

Máquinas Especializadas

Specialized Machine

Equipo Relacionado

Related Equipment

Taladro de Biselado & Casquillo

Bush & Chamfering Drill

Milling Chuck

Collet Holder

"R" Zero Holder

Hydraulic Chuck

Shrink Fit

Tapping Chuck

Arbors

Function Holder

Turning Tool

Retention Stud

Tool Shank Dimensions

Seal Unit

Al reemplazar la unidad de sellado, favor de comprar tanto el cuerpo como la manga de sellado.
When replacing seal unit, please purchase both body and seal sleeve.

Cuerpo de la unidad de sellado
Seal unit body

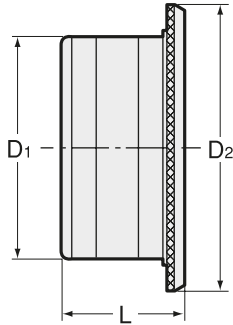

Manga de sellado
Seal sleeve

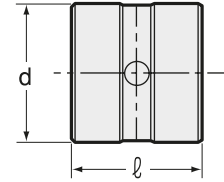

Unidad : Métrico (pulgadas)
Unit : Metric (inch)

Código Code	Modelo Model	Cuerpo de la unidad de sellado Seal unit body			Manga de sellado Seal sleeve	
		D1	D2	L	d	ℓ
2984 00000001	CS-1	56 (2.205)	71 (2.795)	31 (1.220)	35 (1.378)	33 (1.299)
2984 00000002	CS-2	67 (2.638)	82 (3.228)	31 (1.220)	45 (1.772)	33 (1.299)
2984 00000003	CS-3	75 (2.953)	90 (3.543)	31 (1.220)	55 (2.165)	33 (1.299)
2984 00000004	CS-4	85	100	31	65	33

El cuerpo de la unidad de sellado y la manga de sellado se fabrican como una unidad.

Seal unit body and seal sleeve are made as one unit.

Cuando sólo reemplace dos sellos, favor de comprar un conjunto de selladores como el que se muestra a continuación.
When replacing 2 seals only, please purchase a seal set as shown below.

Sello
Seal



Manga de sellado
Seal sleeve

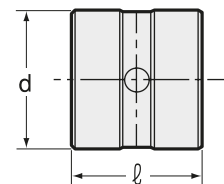

Unidad : Métrico (pulgadas)
Unit : Metric (inch)

Código Code	Modelo Model	Sello Seal			Manga de sellado Seal sleeve		
		D	L	Qty	d	ℓ	Qty
2984 10000001	CS-1P	47 (1.850)	4.8 (0.189)	2	35 (1.378)	33 (1.299)	1
2984 10000002	CS-2P	57 (2.244)	4.8 (0.189)	2	45 (1.772)	33 (1.299)	1
2984 10000003	CS-3P	67 (2.638)	4.8 (0.189)	2	55 (2.165)	33 (1.299)	1
2984 10000004	CS-4P	77	4.8	2	65	33	1

1. Dos sellos y una funda de sellado se fabrican como una unidad.
2. Dirijase a "Cómo reemplazar la unidad de sellado" en el Instructivo.

1. 2 seals and 1 seal sleeve are made as one unit.
2. Refer to "How to replace seal unit" in the instruction manual.

Bloque de posicionamiento

Positioning Block

Antes de usar el Inductor de refrigerante NT, el Hyper Spindle o los Angle Heads, favor de instalar un bloque de posicionamiento en su centro de maquinado.

Before using NT's Coolant Inducer, Hyper Spindle or Angle Heads, please install a positioning block to your M/C.

¿Qué es la dimensión "A"?

What is "A" dimension?

La dimensión "A" es la distancia axial entre la línea de calibración y el fondo de la ranura del bloque de posicionamiento. Dicha dimensión "A" es MUY importante para poder usar correctamente nuestros productos de émbolo. El usar una medida incorrecta del émbolo puede ocasionar daños en los productos. NT TOOL puede ayudarle a medir esta dimensión "A". Favor de llamarnos con esta página abierta. Asimismo, el "dibujo de la superficie del husillo" del fabricante de su máquina.

"A" dimension is an axial distance between your machine's gauge line and the bottom of the groove of the positioning block. This "A" dimension is VERY important to be able to use our plunger products correctly. Using incorrect plunger size may result in damaging the products. NT TOOL can help you measuring this "A" dimension. Please call us with this page opened. Also, your "Spindle surface drawing" from your machine manufacturer is helpful.

Bloque de posicionamiento
La superficie del husillo donde se montará el bloque de posicionamiento puede ser más bajo que la línea de calibración.
Positioning Block
Spindle surface where the positioning block will be mounted on could be lower than gauge line.

A Dimension (+)

El émbolo debe empujarse hasta 6 mm cuando esté unido al bloque de posicionamiento. (Excepto en el zanco BT30 es de 5 mm)
The plunger needs to be pushed down 6mm when engaged with the positioning block. (Except BT30 shank is 5mm)

Cuando el émbolo está unido al bloque de posicionamiento
When the plunger is engaged with the positioning block.

Bloque de posicionamiento
La superficie del husillo donde se montará el bloque de posicionamiento puede ser más bajo que la línea de calibración.
Positioning Block
Spindle surface where the positioning block will be mounted on could be lower than gauge line.

A Dimension (-)

El émbolo debe empujarse hasta 6 mm cuando esté unido al bloque de posicionamiento. (Excepto en el zanco BT30 que es de 5 mm)
The plunger needs to be pushed down 6mm when engaged with the positioning block. (Except BT30 shank is 5mm)

Cuando el émbolo está unido al bloque de posicionamiento
When the plunger is engaged with the positioning block.

Para modificar los bloques de posicionamiento estándar de NT a su máquina, se debe hacer la placa de fijación que se muestra a continuación. Para conocer más, favor de contactar a NT TOOL.

In order to retrofit NT standard positioning blocks to your existing machine, a base plate shown below must be made. For more details, please contact NT TOOL.

- Favor de proporcionarnos información detallada sobre su M/C al hacer un orden de compra de un bloque de posicionamiento especial.
- Cuando use un bloque de posicionamiento hecho por otra empresa, el ángulo de ahusamiento debe ser el mismo que en nuestro producto.
- Please provide us with the detailed information of your existing M/C when you place an order for a special positioning block.
- When using a positioning block made by other company, the taper angle must be the same as our product.

Datos sobre la dimensión de los bloques de posicionamiento
Positioning Blocks Dimensional data

Antes de usar el Inductor de refrigerante NT, el Hyper Spindle o los Angle Heads, instalar un bloque de posicionamiento en su M/C.

Before using NT's Coolant Inducer, Hyper Spindle or Angle Heads, please install a positioning block to your M/C.

Número de la parte Part Number	Portaherramienta adecuado Suitable tool holders
IGB-1	40/50 Hyper Spindles
IGB-2	40/50 Coolant Inducer (and Hyper Spindles)
IGB-3	Angle Heads BT30
IGB-4	Angle Heads Fixed types (BT40, CAT40, HSK63A)
IGB-5	Angle Heads con suministro de refrigerante a través del centro (BT40, CAT40, HSK63A) Angle Heads Fixed types with center-thru coolant feed (BT40, CAT40, HSK63A)
IGB-6	Angle Heads de tipo fijo (BT50, CAT50, HSK100A) y Tipo flexible (BT40, BT50, CAT40, CAT50, HSK63A, HSK100A) Angle Heads Fixed Types (BT50, CAT50, HSK100A) and Flexible Types (BT40, BT50, CAT40, CAT50, HSK63A, HSK100A)
IGB-7	Angle Heads de tipo fijo con suministro de refrigerante a través del centro (BT50, CAT50, HSK100A) Angle Heads Fixed Types with center-thru coolant feed (BT50, CAT50, HSK100A)

IGB-2 (40/50 Coolant Inducer y/and Hyper Spindles)

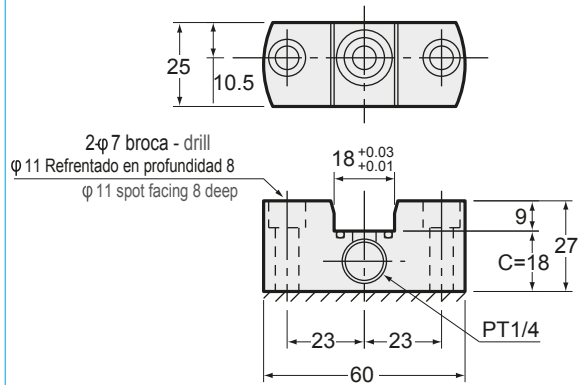

IGB-1 (40/50 Hyper Spindle)

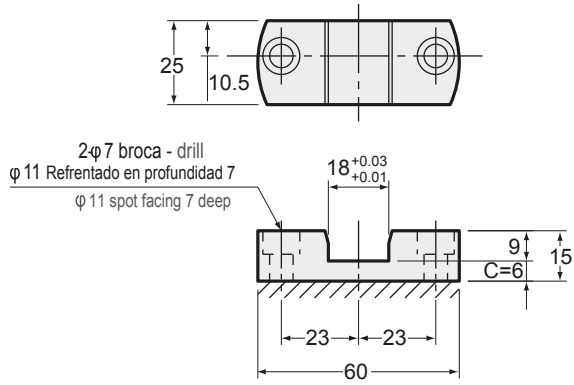

IGB-3 (Angle Heads BT30)

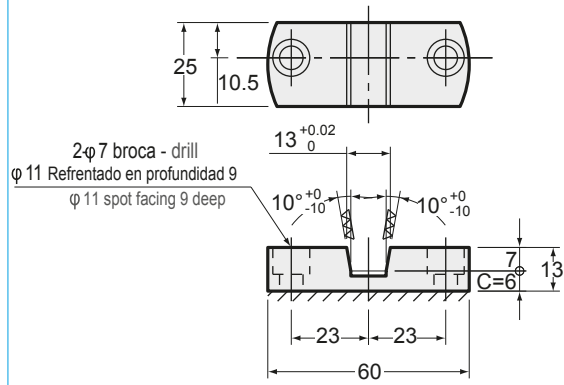

IGB-4 Angle Heads de tipo fijo (BT40, CAT40, HSK63A)
Angle Heads Fixed types (BT40, CAT40, HSK63A)

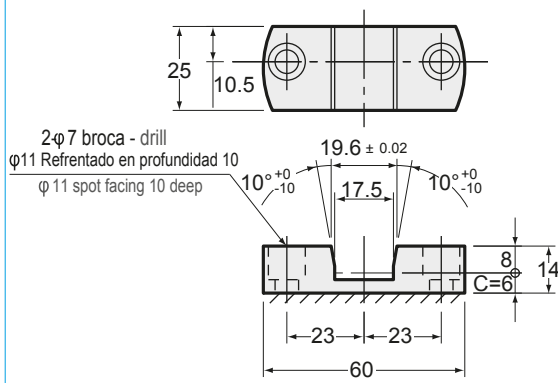

IGB-5 Angle Heads de tipo fijo con suministro de refrigerante a través del centro (BT40, CAT40, HSK63A)
Angle Heads Fixed types with center-thru coolant feed (BT40, CAT40, HSK63A)

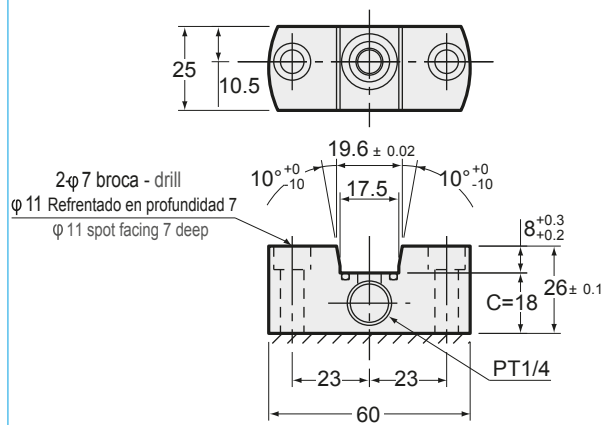

IGB-6 Angle Heads de tipo fijo (BT50, CAT50, HSK100A) y Tipo flexible (BT40, BT50, CAT40, CAT50, HSK63A, HSK100A)
Angle Heads Fixed types (BT50, CAT50, HSK100A) and Flexible Types (BT40, BT50, CAT40, CAT50, HSK63A, HSK100A)

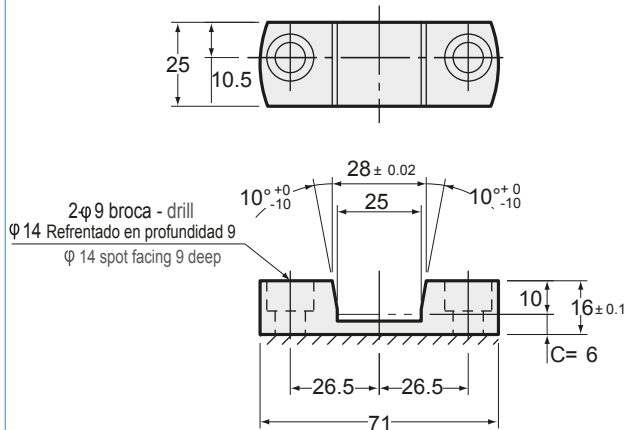

IGB-7 Angle Heads de tipo fijo con suministro de refrigerante a través del centro (BT50, CAT50, HSK100A)
Angle Heads Fixed Types with center-thru coolant feed (BT50, CAT50, HSK100A)

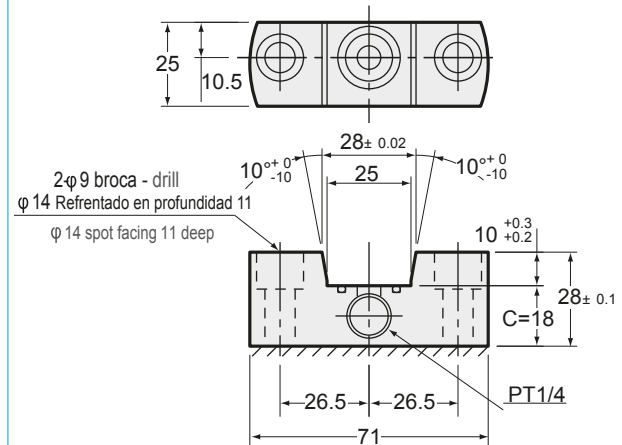

Turning Tools for brother's SPEEDIO M140X1

- Para refrentado exterior
- For External / Facing

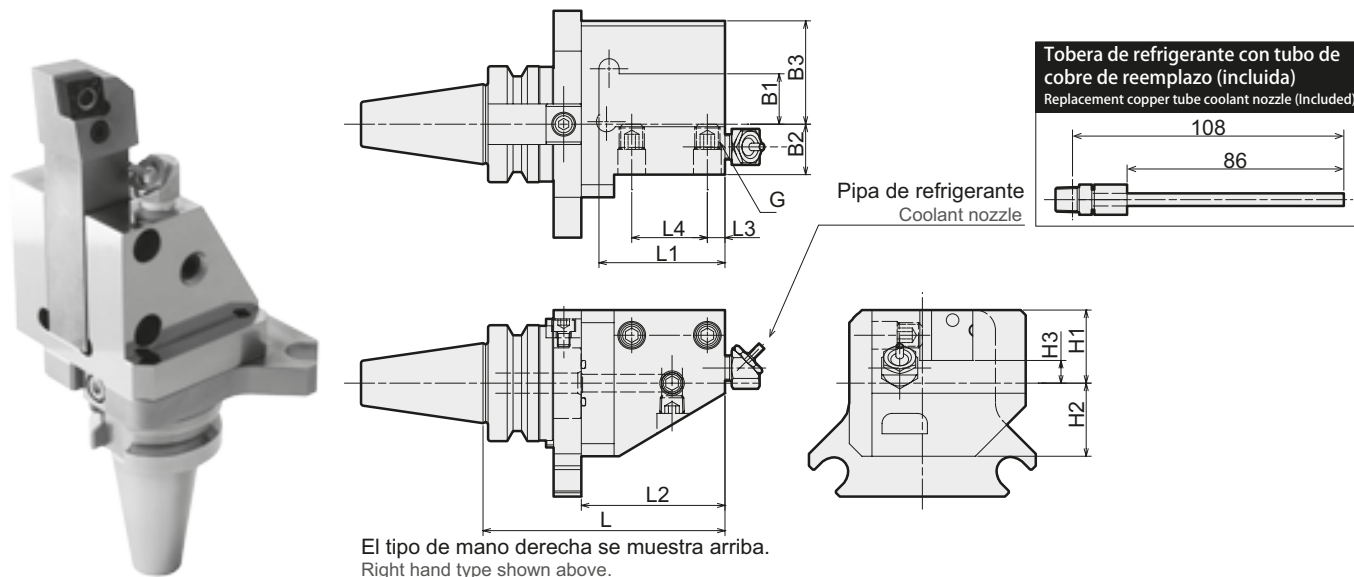

Código Code	Modelo Model	L	L1	L2	L3	L4	B1	B2	B3	H1	H2	H3	G	Kg
2120 12020098	BT30 -SBV2020	98	50	57	7	30	20	20	41	29	29	9	M10	2.0
2120 12120098														

1. La dirección de la pipa de refrigerante es ajustable.
2. Favor de reemplazar la pipa de refrigerante estándar con la pipa de refrigerante con tubo de cobre (incluida) en caso de que el refrigerante no llegue al borde de corte.
3. Favor de cortar un pedazo de la pipa en caso de ser necesario.

1. Direction of the coolant nozzle is adjustable.
2. Please replace the standard coolant nozzle with the replacement copper tube coolant nozzle (included) in case coolant is not reaching the cutting edge.
3. Please shorten a square bit if necessary.

Ejemplo para Ordenar - Ordering Example

BT30 - SBV 2020 R - 98

Interfaz y diámetro de husillo

Shank size

Mano izquierda - I Longitud de
Mano derecha - D proyección

Left hand - L
Right hand - R Projection length (L)

Turning Tools for brother's SPEEDIO M140X1

- Para Refrentado
- For Facing

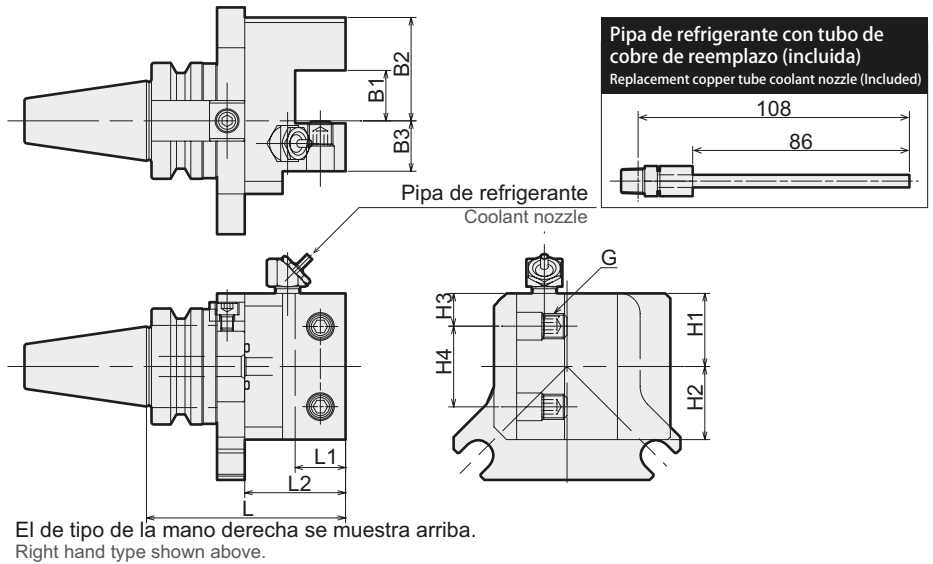

Código Code	Modelo Model	L	L1	L2	B1	B2	B3	H1	H2	H3	H4	G	Kg	
2120 11020081	BT30 -SBH2020 <u>R</u>	-81	81	20	40	20	41	20	29	29	13	32	M10	1.8
2120 11120081														

- La dirección de la boquilla de refrigerante es ajustable.
 - Favor de reemplazar la pipa de refrigerante estándar con la pipa de refrigerante con tubo de cobre (incluida) en caso de que el refrigerante no llegue al borde de corte.
 - Favor de cortar un pedazo de la pipa en caso de ser necesario.
- Direction of the coolant nozzle is adjustable.
 - Please replace the standard coolant nozzle with the replacement copper tube coolant nozzle (included) in case coolant is not reaching the cutting edge.
 - Please shorten a square bit if necessary.

Ejemplo para Ordenar - Ordering Example

BT30 - SBH 2020 R - 81Interfaz y
diámetro
de husilloMano izquierda - I
Mano derecha - DLongitud de
proyección

Shank size

Left hand - L
Right hand - RProjection
length (L)

Turning Tools for brother's SPEEDIO M140X1

- Para Refrentado
- For Boring bar

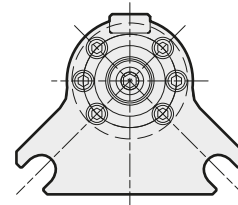
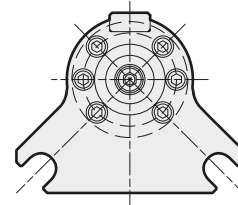
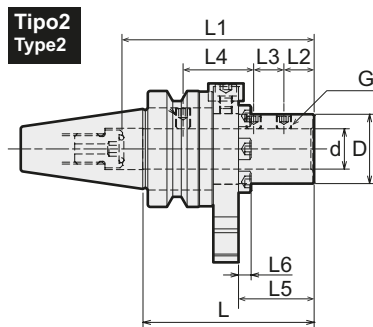
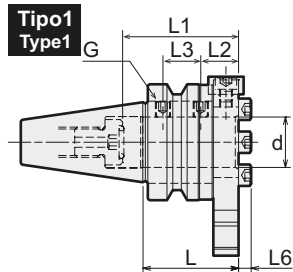

Código Code	Modelo Model	Tipo Type	d	D	L	L1	L2	L3	L4	L5	L6	G	Kg
2120 00010038	BT30 -TSB10 -38	1	10	-	38	40	15	15	-	-	5	M6	0.8
2120 00010068	BT30 -TSB10 -68	2	10	20	68	45	12	12	-	30	5	M6	0.9
2120 00012038	BT30 -TSB12 -38	1	12	-	38	40	15	15	-	-	5	M6	0.8
2120 00012068	BT30 -TSB12 -68	2	12	22	68	65	12	12	26	30	5	M6	0.9
2120 00016038	BT30 -TSB16 -38	1	16	-	38	46	15	15	-	-	5	M6	0.8
2120 00016068	BT30 -TSB16 -68	2	16	27.5	68	76	12	12	26	30	5	M6	0.9
2120 00020038	BT30 -TSB20 -38	1	20	-	38	46	15	15	-	-	5	M6	0.8

Ejemplo para Ordenar - Ordering Example

BT30	-	TSB	20	-	38
Interfaz y diámetro de husillo			Diámetro Interno		Longitud de proyección
Shank size			I.D. (d)		Projection length (L)

Tornillo de retención - Retention Stud

No compatible con refrigerante a través del centro
Center-thru noncompliant

Compatible con refrigerante a través del centro
Center-thru compliant

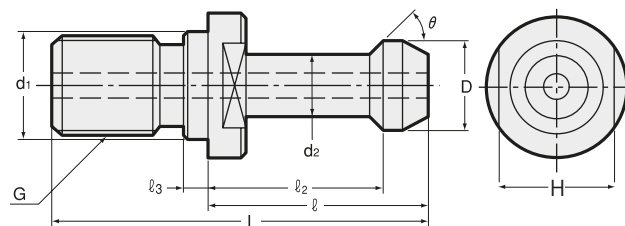
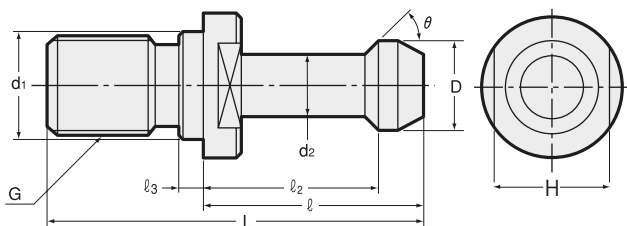

Tipo1
Type1

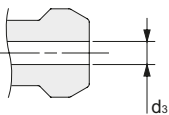

Tipo2
Type2

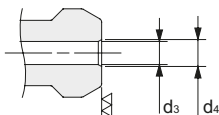

Tipo3
Type3

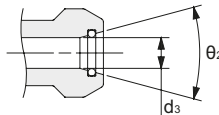

Tipo4
Type4

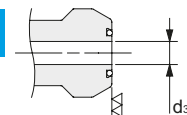

El ancho de la dimensión de "H" en cada tornillo de retención se encuentra en la indicación de la derecha.
The width of "H" dimension on each pull stud is as follows.

BT30 : 13mm

BT35 : 13mm

BT40 : 19mm

BT45 : 24mm

BT50 : 30mm

Código Code	Modelo Model	Zanco Shank	Estándar Standard	Con función refrigerante por centro Center-thru	D _{0-0.1}	d ₁ h7	d ₂	L	l	l ₂	l ₃	G	θ	Tipo Type	d ₃	θ ₂	d ₄
0754 0000000	PSB -0	BT30	MAS-1	—	11	12.5	7	43	23	18	4	M12	45°	—	—	—	—
0754 0000100	PSB -0A	BT30	MAS-2	—	11	12.5	7	43	23	18	4	M12	60°	—	—	—	—
0754 100000000	PSB -0-CH	BT30	MAS-1	○	11	12.5	7	43	23	18	5.5	M12	45°	1	2.5	—	—
0754 10000100	PSB -0A-CH	BT30	MAS-2	○	11	12.5	7	43	23	18	5.5	M12	60°	1	2.5	—	—
0754 00000030	PSB -30P	BT30	JIS	○	12	12.5	8	43	23.4	18.4	6	M12	75°	1	4	—	—
0754 10000401	PSB -1T	BT30	—	○	11	12.5	8	43	23	18	5.5	M12	45°	1	4	—	—
0754 00000026	PSB -26	BT30	—	○	11	12.5	7.5	43	23	18	4	M12	60°	1	2.5	—	—
0754 00000302	PSB -2M	BT35	MAS-1	—	13	12.5	8.5	48	28	22.5	4	M12	45°	—	—	—	—
0754 00000001	PSB -1	BT35	—	—	13.7	13	8.9	53	28	22.5	5	M12	60°	—	—	—	—
0754 00000002	PSB -2	BT35	—	—	10	13	7	43	25	20	3	M12	45°	—	—	—	—
0754 00000003	PSB -3	BT40	MAS-1	—	15	17	10	60	35	28	5	M16	45°	—	—	—	—
0754 00000004	PSB -4	BT40	MAS-2	—	15	17	10	60	35	28	5	M16	60°	—	—	—	—
0754 00000009	PSB -9	BT40	—	—	15	17	10	54.6	30	23	5	M16	90°	—	—	—	—
0754 00000010	PSB -10	BT40	—	—	15	17	10	50	25	18	5	M16	90°	—	—	—	—
0754 00000011	PSB -11	BT40	—	—	15	17	10	60	35	28	5	M16	90°	—	—	—	—
0754 10000003	PSB -3-CH	BT40	MAS-1	○	15	17	10	60	35	28	7	M16	45°	1	4	—	—
0754 00000031	PSB -31	BT40	MAS-1	○	15	17	10	60	35	28	7	M16	45°	3	3	30°	—
0754 10000004	PSB -4-CH	BT40	MAS-2	○	15	17	10	60	35	28	7	M16	60°	1	4	—	—
0754 00000038	PSB -38	BT40	MAS-2	○	15	17	10	60	35	28	7	M16	60°	3	3	30°	—
0754 00000040	PSB -40P	BT40	JIS	○	19	17	14	54	29	23	7	M16	75°	1	7	—	—
0754 00000032	PSB -32	BT40	JIS	○	19	17	14	54	29	23	7	M16	75°	1	4	—	—
0754 00000023	PSB -23	BT40	—	○	18.8	17	12.5	44.1	19.1	14	5	M16	45°	1	7	—	—
0754 00000025	PSB -25	BT40	—	○	19	17	14	54	29	23	7	M16	75°	3	7	30°	—
0754 00000005	PSB -5	BT45	MAS-1	—	19	21	14	70	40	31	6	M20	45°	—	—	—	—
0754 00000007	PSB -7	BT50	MAS-1	—	23	25	17	85	45	35	8	M24	45°	—	—	—	—
0754 00000008	PSB -8	BT50	MAS-2	—	23	25	17	85	45	35	8	M24	60°	—	—	—	—
0754 00000013	PSB -13	BT50	—	—	25	25	18	95	55	45.5	8	M24	60°	—	—	—	—
0754 00000014	PSB -14	BT50	—	—	23	25	17	85	45	35	8	M24	90°	—	—	—	—
0754 00000016	PSB -16	BT50	—	—	21	25	15	105	63	55	5	M24	45°	—	—	—	—
0754 00000017	PSB -17	BT50	—	—	24	25	18	71	31	23	8	M24	90°	—	—	—	—
0754 00000019	PSB -19	BT50	—	—	23	25	17	85	45	35	8	M24	90°	—	—	—	—
0754 00000022	PSB -22	BT50	—	—	23	25	18	104	64	56	8	M24	4R	—	—	—	—
0754 10000007	PSB -7-CH	BT50	MAS-1	○	23	25	17	85	45	35	10	M24	45°	1	6	—	—
0754 00000029	PSB -29	BT50	MAS-1	○	23	25	17	85	45	35	10	M24	45°	2	4.5	—	5
0754 00000033	PSB -33	BT50	MAS-1	○	23	25	17	85	45	35	10	M24	45°	3	6	30°	—
0754 00000035	PSB -35	BT50	MAS-1	○	23	25	17	85	45	35	10	M24	45°	3	5.5	60°	—
0754 10000008	PSB -8-CH	BT50	MAS-2	○	23	25	17	85	45	35	10	M24	60°	1	6	—	—
0754 00000036	PSB -36	BT50	MAS-2	○	23	25	17	85	45	35	10	M24	60°	3	5.5	60°	—
0754 00000039	PSB -39	BT50	MAS-2	○	23	25	17	85	45	35	10	M24	60°	3	6	30°	—
0754 00000050	PSB -50P	BT50	JIS	○	28	25	21	74	34	25	10	M24	75°	1	10	—	—
0754 00000037	PSB -37	BT50	JIS	○	28	25	21	74	34	25	10	M24	75°	3	5.5	60°	—
0754 00000024	PSB -24	BT50	—	○	29	25	20.9	65.2	25.2	17.6	8	M24	45°	1	10	—	—
0754 00000027	PSB -27	BT50	—	○	23	25	17	85	45	35	10	M24	90°	3	8	30°	—
0754 00000028	PSB -28	BT50	—	○	23	25	17	85	45	35	10	M24	90°	4	6	—	—

Tabla de selección del tornillo de retención

Retention Stud Selection Table

1. Esta tabla de selección describe los tornillos de retención estándar para cada máquina estándar. Favor de revisar el manual de funcionamiento de las máquinas para elegir el tipo de tornillo de retención adecuado.

2. Cabe mencionar que nuestro tornillo de retención con función refrigerante a través del centro puede no ser compatible con ciertas M/C debido a sus especificaciones.

1. This selection table describes standard retention studs for each of standard machines. Please check operation manual of machines to select appropriate type of the retention studs.

2. Take note that our center through coolant retention stud may not be used on certain M/C because of specifications.

Fabricante de máquina Machine Maker	M/C Modelo M/C Model	BT	Tornillo de retención con refrigerante a través del centro Center Through Coolant	PSB
IKEGAI	HM3	BT30	—	PSB-30P
	TV4, TH500	BT40	—	PSB-3
	TV5, TH600, TVU5, THU600, NB110T, NB130T, HM5	BT50	—	PSB-7
	TVU4, THU500	BT40	●	PSB-40P
ENSHU	GE Series JE Series E130, ES400, EV360 (T)	BT30	—	PSB-0A
	GE Series JE Series EV Series ES450	BT40	—	PSB-4
	GE Series JE Series EV Series	BT50	—	PSB-8
	GE Series JE Series E130, ES400, EV360 (T)	BT30	●	PSB-0A -CH
	GE Series JE Series EV Series ES450	BT40	●	PSB-4 -CH
OKUMA	GE Series JE Series EV Series	BT50	●	PSB-8 -CH
	MU Series MA-400H, MB Series	BT40	—	PSB-4
	MILLAC Series	BT40	—	PSB-3
	MA Series MB Series MCR Series MCM-B, MCV-AII, MILLAC Series	BT50	—	PSB-8
	MU Series MA-400H, MB Series MILLAC Series	BT40	●	PSB-31, PSB-38, PSB-32
OKK	MA Series MB Series MCR Series MCM-B, MCV-AII, MILLAC Series	BT50	●	PSB-33, PSB-39
	VM/R Series VP Series VB53, VC51, GR400, HMC400, HM Series VC-X350, VC-X500	BT40	—	PSB-3
	VM/R Series KCV Series GC Series HM Series MCH Series	BT50	—	PSB-19
	VM/R Series VP Series VB53, VC51, GR400, HMC400, HM Series VC-X350, VC-X500	BT40	●	PSB-3-CH
	VM/R Series KCV Series HM Series MCH Series	BT50	●	PSB-28
KITAMURA	Mycenter Series Mytrunnion Series	BT30	●	PSB-30P
	Mycenter Series Mytrunnion Series Supercell-400, BRIDGE center	BT40	●	PSB-40P
	Mycenter Series BRIDGE center	BT50	●	PSB-50P
KIRA	PCV-30, KPC-30a, KPC-30b, KPC-30b-6vs, HPC-30Vb-2AQC, HPC-30Vb-2API, HPC-30Vb-350s, HPC-30Vb-350s-2AQC, PC-30H	BT30	—	PSB-0
	VTC-40a, VTC-40b, KN-40Va-500s, KN-40Va-500s-2API, KN-40Vb-500s, KN-40Vb-500s-2API, KN-40Hb-500s, KN-40Hb-500s-2APC	BT40	—	PSB-3
	PCV-30, KPC-30a, KPC-30b, KPC-30b-6vs, HPC-30Vb-2AQC, HPC-30Vb-2API, HPC-30Vb-350s, HPC-30Vb-350s-2AQC, PC-30H	BT30	●	PSB-30P
	VTC-40a, VTC-40b, KN-40Va-500s, KN-40Va-500s-2API, KN-40Vb-500s, KN-40Vb-500s-2API, KN-40Hb-500s, KN-40Hb-500s-2APC	BT40	●	PSB-3-CH
	KCW-5VR, KCW-5VS	BT30	—	PSB-0
KIWA	KNH400/426, D433 Series EX Series PX Series PMM40, AD-8	BT40	—	PSB-3
	KCW-5VR, KCW-5VS	BT30	●	PSB-0-CH
	KNH400/426, D433 Series EX Series PX Series PMM40, AD-8	BT40	●	PSB-3-CH
	KCW-10V, V41-5X, KH-41, KH-45, V21i-R, V21i-S, V21i-B	BT40	●	PSB-40P
	KCW-11V, KH-55	BT50	●	PSB-50P
KURAKI	KBT, KBF, KBM, KBH, KGD, CMN, KMP	BT50	—	PSB-7
	CM-210G	BT30	—	PSB-0
	B Series CM-350G	BT40	—	PSB-11
SHIZUOKA	B Series	BT50	—	PSB-19
	CMV Series	BT40	—	PSB-4
	CMV Series CMV Series DC Series HF Series C Series RB Series AIC Series MAC Series FSP Series HPS Series PARTE Series	BT50	—	PSB-8
	CMV Series	BT40	●	PSB-4-CH
	CMV Series DC Series HF Series PC Series RB Series AIC Series MAC Series FSP Series HPS Series PARTE Series	BT50	●	PSB-8-CH
SUGINO	NSV-1555, SCV-1555, SCV-C1555, SCH-1522, SCH-15B	BT30	—	PSB-0A
	MAC-V1E/430VP	BT40	—	PSB-3
TAKISAWA	MAC-V40/Y520	BT40	●	PSB-40P
	VMA3-III, VML3-III, VMC3-III, VA32A	BT30	—	PSB-0
TSUGAMI	VMA4-III, VLA4-III	BT40	—	PSB-3
	FMA3-III, FMA5-III	BT40	—	PSB-4
	VMT4-III, VLT4-III	BT40	—	PSB-40P
	BSF-150C, BTD Series BTH Series BF-130B, BP-130, R22/150, BTF-130.R22, BTU-14, BMC800/1000, TUE Series TUD Series TSS-C Series TMD Series	BT50	—	PSB-7, PSB-8
TOSHIBA	BSF-150C, BTD Series BTH Series BF-130B, BP-130, R22/150, BTF-130.R22, BTU-14, BMC800/1000, TUE Series TUD Series TSS-C Series TMD Series	BT50	●	PSB-29, or Special

Fabricante de máquina Machine Maker	M/C Modelo M/C Model	BT	Tornillo de retención con refrigerante a través del centro Center Through Coolant	PSB
TOYOSK	TVT Series THMC Series TVMC310	BT30	—	PSB-0A
	H46, THMC410	BT40	—	PSB-3
	H46, THMC410	BT40	●	PSB-3-CH
JTEKT	FV Series, UX Series e Series	BT40	—	PSB-3
	FH Series	BT40	—	PSB-3, PSB-10
	FV Series, RB Series, SB Series e Series	BT50	—	PSB-7
	FH Series, FA Series	BT50	—	PSB-7, PSB-17
NIGATA	FV Series e Series, FH Series	BT40	●	Especial / Special
	FV Series e Series, FH Series, FA Series	BT50	●	Especial / Special
NISHIDA MACHINE	HN Series (Standard), ULTY Series (Standard)	BT50	—	PSB-8
	HFA3 Series, HLB3 Series, HLA3S Series, VFR3 Series	BT30	—	PSB-0
	HA40 Series, HFB-4A Series, HLB-4A Series, HAB4 Series, HFB4 Series, NHF4 Series	BT40	—	PSB-3
	HFA5 Series, HFB5 Series, HS Series	BT50	—	PSB-8
	HFA3 Series, HLB3 Series, HLA3S Series, VFR3 Series	BT30	●	PSB-0-CH
	HA40 Series, HFB-4A Series, HLB-4A Series, HAB4 Series, HFB4 Series, NHF4 Series	BT40	●	PSB-3-CH
KOMATSU NTC	HFA5 Series, HFB5 Series, HS Series	BT50	●	PSB-8-CH
	N3 Series, Z3V, Zu3500	BT30	—	PSB-0
	Z Series, TMC Series, N4H7	BT40	—	PSB-3
	N5H, ZV Series	BT50	—	PSB-7
	N3 Series, Z3V, Zu3500	BT30	●	PSB-0-CH
	Z Series, TMC Series, N4H7	BT40	●	PSB-3-CH
FANUC	N5H, ZV Series	BT50	●	PSB-7-CH
	ROBODRILL	BT30	—	PSB-0
BROTHER	ROBODRILL	BT30	●	PSB-1T
	TC-S2DN, TC-22B/TC-22B-O, TC-R2B, TC-32BN QT/FT, TC-31B, SPEEDIO Series (S500X1, S700X1, M140X1)	BT30	—	PSB-0A
HORKOS	TC-S2DN, TC-22B/TC-22B-O, TC-R2B, TC-32BN QT/FT, TC-31B, SPEEDIO Series (S500X1, S700X1, M140X1)	BT30	●	PSB-26
	RS50H, ES50H, NJ50	BT30	—	PSB-0
	RM70H, RM70V, DM70H, NS70, MBE, MOH, TM70M	BT40	—	PSB-3
	RM100H, DM100H, NM100, HFN-C50H, TM100H	BT50	—	PSB-7
	RS50H, ES50H, NJ50	BT30	●	PSB-0-CH
	RM70H, RM70V, DM70H, NS70, MBE, MOH, TM70M	BT40	●	PSB-3-CH
HOWA MACHINERY	RM100H, DM100H, NM100, HFN-C50H, TM100H	BT50	●	PSB-7-CH
	MKN-355VCJ, MKN-335VT, MBN-350H α	BT30	—	PSB-0
	MBN-450HQ1, MBN-450H α , MBN-455HN	BT40	—	PSB-3
	MBN-580H	BT50	—	PSB-7
	MBN-350H α	BT30	●	PSB-0-CH
	MBN-450HQ1, MBN-450H α , MBN-455HN	BT40	●	PSB-3-CH
HOMMA	MBN-580H	BT50	●	PSB-7-CH
	HVM Series (High Speed)	BT40	—	PSB-40P
	FM Series, TAC-M Series, STAC-M Series, HVM Series (Standard, HTM Series)	BT50	—	PSB-8
	HVM Series (High Speed)	BT40	●	PSB-40P
MAKINO	FM Series, TAC-M Series, STAC-M Series, HVM Series (Standard, HTM Series)	BT50	●	PSB-8-CH
	FB127, BH	BT40	—	PSB-3, PSB-4, PSB-40P
	A99E, A100E, MCC Series, MCD1816	BT50	—	PSB-7, PSB-8, PSB-50P
	V33i, V56i, V77, G5, a51nx/a61nx/a61nx-5E	BT40	●	PSB-3-CH, PSB-4-CH, PSB-40P
MATSUURA	V77L, V99/V99L, G10, a71, a81/a82, a81M/a82M, a92	BT50	●	PSB-7-CH, PSB-8-CH, PSB-50P
	LX Series, FXII	BT30	—	PSB-30P
	H.Plus Series, V.Plus Series, R.Plus-800, RA-1X/2G, Mold.Plus-800, MAM72 Series, MC Series, MX Series	BT40	—	PSB-40P
	H.Plus Series, MAM72-100H	BT50	—	PSB-50P
	LX Series, FXII	BT30	●	PSB-30P
	H.Plus Series, V.Plus Series, R.Plus-800, RA-1X/2G, Mold.Plus-800, MAM72 Series, MC Series, MX Series	BT40	●	PSB-40P
H.Plus Series, MAM72-100H	BT50	●	PSB-50P	

Fabricante de máquina Machine Maker	M/C Modelo M/C Model	BT	Tornillo de retención con refrigerante a través del centro Center Through Coolant	PSB
MITSUI SEIKI	U50A, HU40-T, VU50A, Vertex55II, Vertex75II, Vertex75xII	BT40	—	PSB-10
	HPX63, HU63EX, HU80EX, HU100, HS8A, H5D, H6D, FH550R/HW550A, FH630R/HW630A, HU50-T, HU63-T, HU100-T, HU50A-5X, HU63A-5X, HU80A-5X, HU100-5X, HU100-5XL, HU100-5XLL, HU100-TS, VU65A	BT50	—	PSB-7
	U50A, HU40-T, VU50A, Vertex55II, Vertex75II, Vertex75xII	BT40	●	PSB-40P
	HPX63, HU63EX, HU80EX, HU100, HS8A, H5D, H6D, FH550R/HW550A, FH630R/HW630A, HU50-T, HU63-T, HU100-T, HU50A-5X, HU63A-5X, HU80A-5X, HU100-5X, HU100-5XL, HU100-5XLL, HU100-TS, VU65A	BT50	●	PSB-7-CH
MITSUBISHI	M-H Series, M-V Series	BT40	—	PSB-3、PSB-4
	DH Series, M-H Series, M-V Series, M-VRD Series, MAF-B Series, MAF-C Series, MAF-E Series, MAF-R Series, MAF-RS Series, MAF-S Series, MG Series, MHT Series, MVR Series, MVR-DX Series	BT50	—	PSB-7、PSB-8
	M-H Series, M-V Series	BT40	●	PSB-3-CH、PSB-4-CH
	DH Series, M-H Series, M-V Series, M-VRD Series, MAF-B Series, MAF-C Series, MAF-E Series, MAF-R Series, MAF-RS Series, MAF-S Series, MG Series, MHT Series, MVR Series, MVR-DX Series	BT50	●	PSB-7-CH、PSB-8-CH
MECTRON	MTV-T360, MTV-T311, MTV-T331W, MTV-C350, MTS-C360, MTS-C360W, MCH-80, MCH-330	BT30	—	PSB-0A
	MTV-T460, MTV-T470, MTV-T452W, MTV-C410	BT40	—	PSB-4
	MTV-T360, MTV-T311, MTV-T331W, MTV-C350, MTS-C360, MTS-C360W, MCH-80, MCH-330	BT30	●	PSB-0A-CH
	MTV-T460, MTV-T470, MTV-T452W, MTV-C410	BT40	●	PSB-4-CH
DMG MORI SEIKI	MAX Series, ACCUMILL Series, ULTIMILL Series	BT30	—	PSB-0
	NV Series, NVX Series, NVD Series, Dura Vertical Series, NHX Series, VS Series, MV-653, SVL5000, SH junior, AFM2400, FM Series	BT40	—	PSB-11
	NV Series, NVX Series, NVD Series, NHX Series, NMH Series, VS Series, MV Series, NH Series, HG Series MH Series	BT50	—	PSB-19
	MAX Series ACCUMILL Series, ULTIMILL Series	BT30	●	PSB-0-CH
	NV Series, NVX Series, NVD Series, Dura Vertical Series, NHX Series, VS Series MV-653, SVL5000, SH junior, AFM2401, FM Series	BT40	●	PSB-25
	NV Series, NVX Series, NVD Series, NHX Series, NMH Series, VS Series, MV Series, NH Series, HG Series, MH Series	BT50	●	PSB-27
YASDA	YBM-N Series, YBM-T Series, YBM-1218V	BT50	—	PSB-7
	H30i, H40i, YBM-Vi40, YBM-640V, YMB-950V, YBM-9150V	BT40	●	PSB-25
	YBM-N Series, YBM-T Series, YBM-1218V	BT50	●	PSB-35、PSB-36、PSB-37
MAZAK	UN Series	BT30	●	S/PSB-30P (Especial / Special)
	VRX Series, VCN Series, VTC Series, SVC Series, FF&F3 Series, FJV Series, MM/SMM Series, HCN Series, FH/PFH Series, μ Series, ANGULAX Series	BT40	●	PSB-23
	VRX Series, VCN Series, MAZATECH V Series, VERSATECH V Series, VORTEX Series, FJV Series, HCN Series, FH Series, μ Series	BT50	●	PSB-24
ROKU-ROKU	RX Series	BT30	—	PSB-0
	KX, LX, MX Series	BT40	—	PSB-3
	GIGA-620	BT40	—	PSB-11

BT

CAT

AHO

HSK-A/E/F/C

HSK-T

C

UTS

Máquinas

Especializadas

Specialized

Machine

Equipo

Relacionado

Related

Equipment

Taladro de

Biselado &

Casquillo

Bush &

Chamfering

Drill

Milling Chuck

Collet Holder

"R" Zero Holder

Hydraulic Chuck

Shrink Fit

Tapping Chuck

Arbors

Function Holder

Turning Tool

Retention Stud

Tool Shank Dimensions

Zanco BT - BT Shank (MAS403-1982)

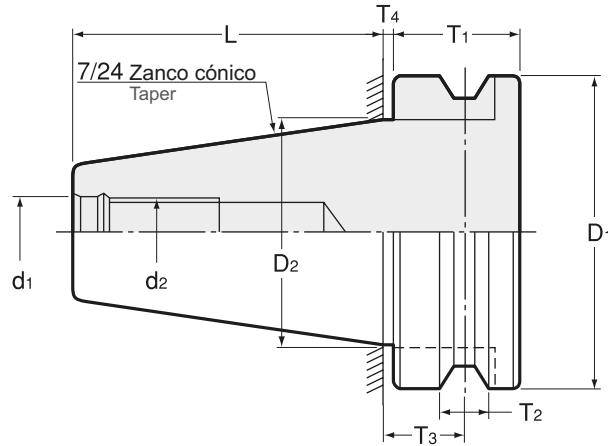

Unidad : Métrico
Unit : Metric

Modelo Model	D1	D2	d1	d2	L ±0.2	T1	T2 ^{+0.1} / ₀	T3 ±0.1	T4	Referencia Reference
BT30	46 ⁰ / _{-0.039}	31.75	12.5 ^{+0.027} / ₀	M12	48.4	20	8	13.6	2	MAS
BT35	53 ⁰ / _{-0.046}	38.1	12.5 ^{+0.027} / ₀	M12	56.4	22	10	14.6	2	MAS
BT35-MS	53 ⁰ / _{-0.046}	38.1	13.0 ^{+0.027} / ₀	M12	56.5	20	10	13.0	2	MS
BT40	63 ⁰ / _{-0.046}	44.45	17.0 ^{+0.027} / ₀	M16	65.4	25	10	16.6	2	MAS
BT45	85 ⁰ / _{-0.054}	57.15	21.0 ^{+0.033} / ₀	M20	82.8	30	12	21.2	3	MAS
BT50	100 ⁰ / _{-0.054}	69.85	25.0 ^{+0.033} / ₀	M24	101.8	35	15	23.2	3	MAS

Zanco BT con refrigerante a través del reborde por los costados (DIN69871/B)

BT Shank Flange-through coolant type (DIN69871/B)

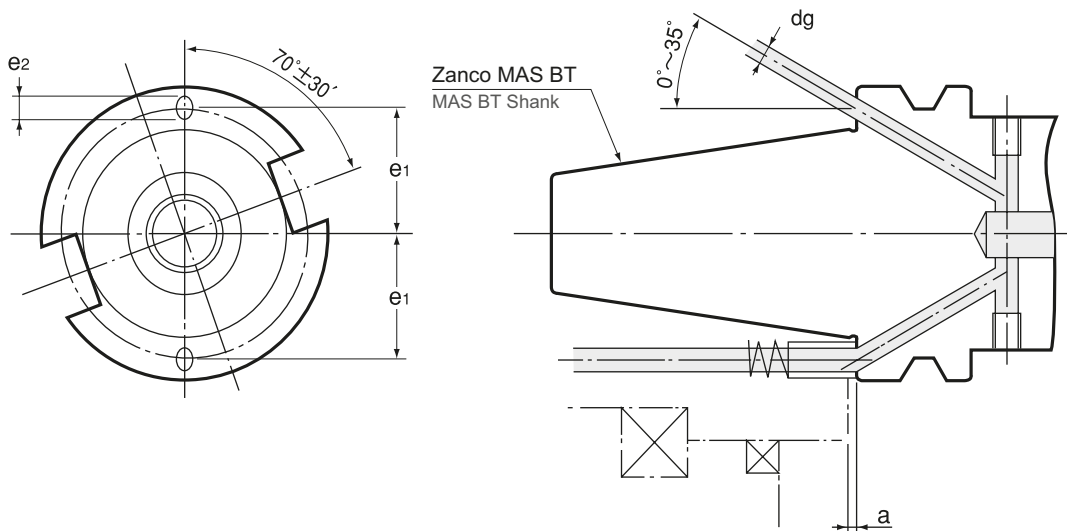

Unidad : Métrico
Unit : Metric

Modelo Model	dg	e1 ±0.1	e2 max	a ±0.1
BT40	4	27	5	2
BT50	6	42	7	3

Zanco cónico nacional - National taper shank

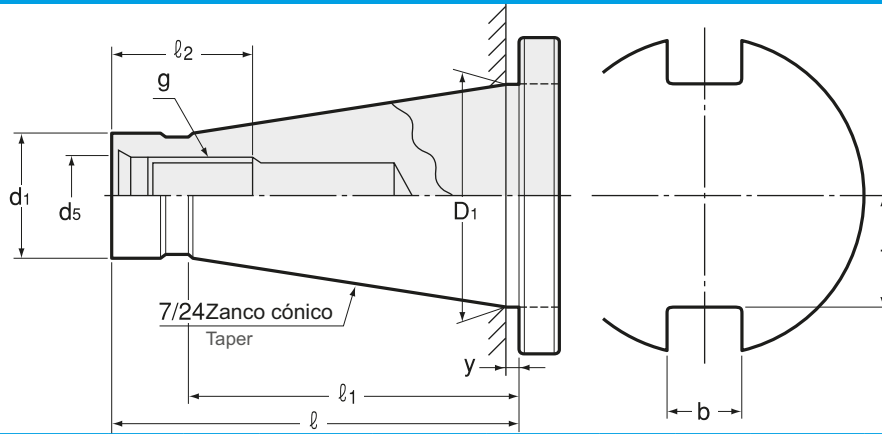

Unidad : Métrico
Unit : Metric

Modelo Model	D1	d1	ℓ Max	ℓ1	y	b	t Max	g	ℓ2	d5
NT30	31.75	17.4 ^{-0.29} _{-0.36}	70	50	1.6	16.1 ^{+0.18} ₀	16.2	M12	24	12.5
NT40	44.45	25.3 ^{-0.30} _{-0.38}	95	67	1.6	16.1 ^{+0.18} ₀	22.5	M16	30	17
NT50	69.85	39.6 ^{-0.31} _{-0.41}	130	105	3.2	25.7 ^{+0.21} ₀	35.3	M24	45	25

JBS

Dimensiones del zanco para JBS - Tool Shank Dimensions For JBS

Zanco JBS - JBS shank

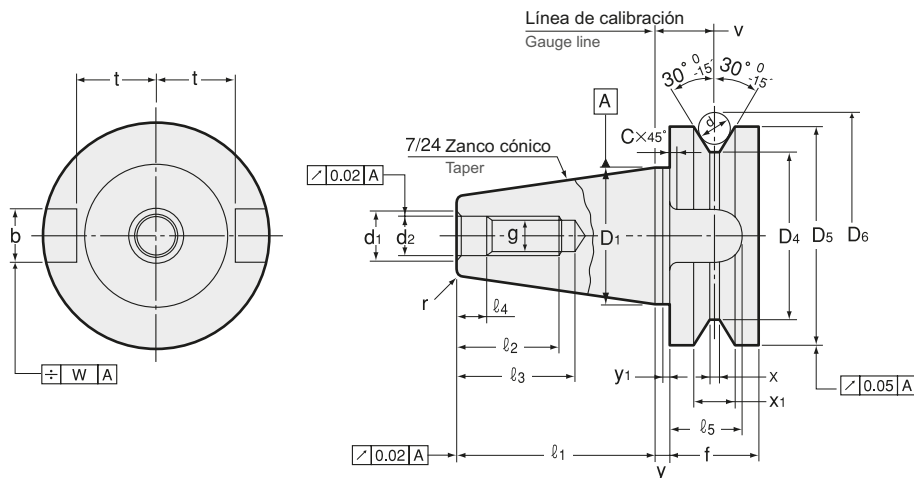

Unidad : Métrico
Unit : Metric

Modelo Model	Parte de Zanco Shank part			Parte de la rosca Thread part						Parte de espiga Tenon part				
	D1	ℓ1 ±0.151	r Max	d1	d2 H8	g H6	ℓ2 Min	ℓ3 Min	ℓ4 ^{+0.5} ₀	b H12	ℓ5 Min	t ⁰ _{-0.2}	W	C Max
5T	12.700	17.5	0.3	5.5	4.5	M4	12	16	5	6.5	8.0	6.5	0.1	0.3
10T	15.875	22	0.3	6.5	5.5	M5	13	18	5	6.5	8.0	8.2	0.1	0.3
15T	19.050	27	0.5	7.5	6.5	M6	15	21	5	8.1	9.5	9.8	0.1	0.3
20T	22.225	33	0.5	9.5	8.5	M8	18	26	6	8.1	9.5	11.4	0.1	0.3
25T	25.400	40	0.5	9.5	8.5	M8	18	26	6	9.6	11.0	13.0	0.1	0.3

Modelo Model	Parte de reborde - Flange part									
	D4	D5 h8	f	v±0.1	X	X1 ^{+0.1} ₀	y±0.4	y1 ⁰ _{-0.4}	d	D6
5T	15	20	10	6.0	2.0	4	1.0	1.0	4	25.072
10T	18	23	10	6.0	2.0	4	1.0	1.0	4	28.072
15T	21	27	11	7.0	2.5	5	1.5	1.5	5	33.340
20T	24	30	11	7.0	2.5	5	1.5	1.5	5	36.340
25T	28	35	13	8.5	3.0	6	2.0	2.0	6	42.608

Pulgada a métrico → Pulgada × 25.4
Métrico a pulgada → Métrico ÷ 25.4 ó métrico por 0.03937



Tamaños especiales / personalizados bajo pedido

BT

BT

CAT

AHO

HSK-A/E/F/C

HSK-T

C

UTS

Máquinas

Especializadas

Specialized

Machine

Equipo

Relacionado

Related

Equipment

Taladro de

Biselado &

Casquillo

Bush &

Chamfering

Drill

Milling Chuck

Collet Holder

"R" Zero Holder

Hydraulic
Chuck

Shrink Fit

Tapping Chuck

Arbors

Function
Holder

Turning Tool

Retention Stud

Tool Shank
Dimensions

Zanco JBS - JBS shank

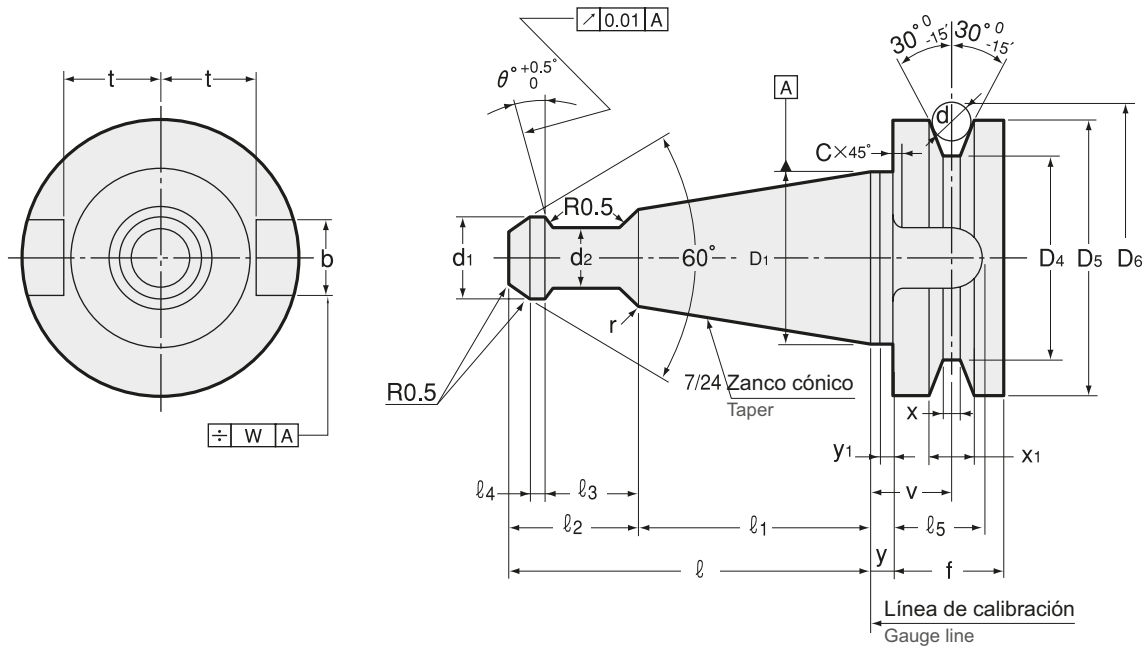

Unidad : Métrico
Unit : Metric

Modelo Model	Parte de Zanco Shank part				Parte de agarre Grip part								θ	
	D1	ℓ1 ±0.15	r Max	ℓ ±0.05 - 0.15	d1 0 -0.1	d2 0 -0.1	r1	ℓ2 0 -0.1	ℓ3 0 -0.1	ℓ4	1 Tipo - Type	2 Tipo - Type		
5TP	12.700	19.5	0.3	28.5	5.0	3	1.0	9.0	6.5	1.0	15° +0.5° 0°	0° +0.5° 0°		
10TP	15.875	24.5	0.3	35.0	6.0	4	1.0	10.5	7.5	1.3	15° +0.5° 0°	0° +0.5° 0°		
15TP	19.050	30.0	0.5	42.0	7.0	5	1.5	12.0	8.5	1.5	15° +0.5° 0°	0° +0.5° 0°		
20TP	22.225	36.5	0.5	50.5	8.5	6	1.5	14.0	10.0	1.8	15° +0.5° 0°	0° +0.5° 0°		
25TP	25.400	44.0	0.5	60.0	10.0	7	1.5	16.0	11.5	2.0	15° +0.5° 0°	0° +0.5° 0°		

Unidad : Métrico
Unit : Metric

Modelo Model	Parte de la espiga Tenon part					Parte del reborde Flange part									
	b H12	ℓ5 Min	t 0 -0.2	W	C Max	D4	D5 h8	f	v ±0.1	X	X1 +0.1 0	y ±0.4	y1 0 -0.2	d	D6
5TP	6.5	8.0	6.5	0.1	0.3	15	20	10	6.0	2.0	4	1.0	1.0	4	25.072
10TP	6.5	8.0	8.2	0.1	0.3	18	23	10	6.0	2.0	4	1.0	1.0	4	28.072
15TP	8.1	9.5	9.8	0.1	0.3	21	27	11	7.0	2.5	5	1.5	1.5	5	33.340
20TP	8.1	9.5	11.4	0.1	0.3	24	30	11	7.0	2.5	5	1.5	1.5	5	36.340
25TP	9.6	11.0	13.0	0.1	0.3	28	35	13	8.5	3.0	6	2.0	2.0	6	42.608



CAT

SISTEMA DE HERRAMENTADO CAT
CAT TOOLING SYSTEM

Super tite-lock Milling Chuck

- Portaherramienta de fresado delgado. Sus ranuras tienen un diseño especial para permitir el acabado en fresa pesado.
- Slim design milling chuck. Specially designed slits enable heavy endmilling.

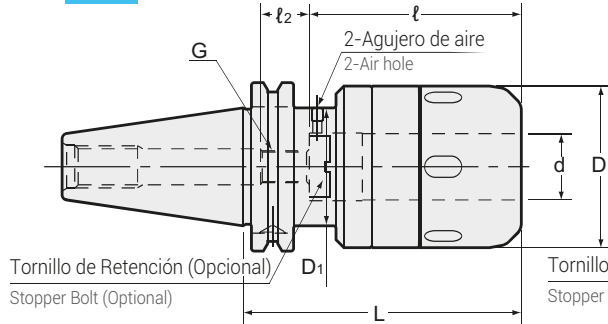
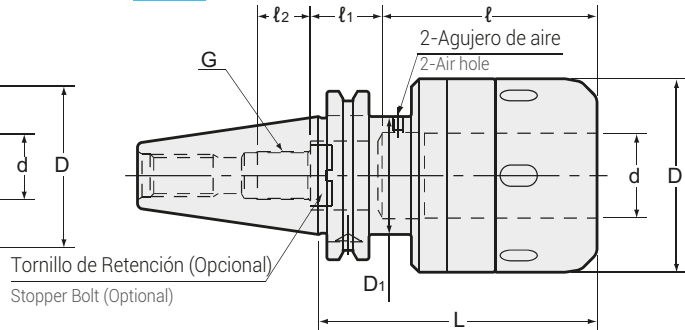
Tipo1
Type1Tipo2
Type2

Precaución / Caution

Favor de girar el anillo de sujeción en sentido contrario a las manecillas del reloj por más de 360 grados después de remover una herramienta de corte.

Please rotate the clamping ring counterclockwise more than 360 degrees after a cutting tool is removed.

Medida en Pulgadas - Inch Sizes

Unidad : Pulgadas
Unit : Inch

Código Code	Modelo Model	Tipo Type	d	D	D1	L	ℓ	ℓ1	ℓ2	G P=1.0	Kg	Llave Inglesa Spanner
1910 50424090	CAT40 -CT0750SA -90	1	0.750	2.047	1.750	3.543	3.150	—	0.591	M12	1.7	HS-2-20
1910 50424105	-105	1	0.750	2.047	1.750	4.134	3.150	—	0.591	M12	1.9	
1910 50424120	-120	1	0.750	2.047	1.750	4.724	3.150	—	0.591	M12	2.1	
1910 50432105	CAT40 -CT1000SA -105	1	1.000	2.402	1.750	4.134	3.150	—	0.591	M12	2.2	HS-2.5-25
1910 50432120	-120	1	1.000	2.402	1.750	4.724	3.150	—	0.591	M12	2.5	
1910 50432135	-135	1	1.000	2.402	1.750	5.315	3.150	—	0.591	M12	2.8	
1910 50440105	CAT40 -CT1250SA -105	2	1.250	2.874	1.750	4.134	3.346	0.906	0.787	M18	2.5	HS-3-32
1910 50440120	-120	2	1.250	2.874	1.750	4.724	3.346	0.906	0.787	M18	3.0	
1910 50440135	-135	2	1.250	2.874	1.750	5.315	4.724	—	0.787	M18	3.4	
1910 50524090	CAT50 -CT0750SA -90	1	0.750	2.047	2.750	3.543	3.150	—	0.591	M12	3.7	HS-2-20
1910 50524105	-105	1	0.750	2.047	2.750	4.134	3.150	—	0.591	M12	3.9	
1910 50524135	-135	1	0.750	2.047	2.750	5.315	3.150	—	0.591	M12	4.3	
1910 50532105	CAT50 -CT1000SA -105	1	1.000	2.402	2.750	4.134	3.150	—	0.591	M12	4.2	HS-2.5-25
1910 50532135	-135	1	1.000	2.402	2.750	5.315	3.150	—	0.591	M12	4.8	
1910 50532165	-165	1	1.000	2.402	2.750	6.496	3.150	—	0.591	M12	5.3	
1910 50540095	CAT50 -CT1250SA -95	1	1.250	2.874	2.750	3.740	4.724	—	0.787	M18	4.2	HS-3-32
1910 50540105	-105	1	1.250	2.874	2.750	4.134	4.724	—	0.787	M18	4.5	
1910 50540120	-120	1	1.250	2.874	2.750	4.724	4.724	—	0.787	M18	4.9	
1910 50540135	-135	1	1.250	2.874	2.750	5.315	4.724	—	0.787	M18	5.4	
1910 50540150	-150	1	1.250	2.874	2.750	5.906	4.724	—	0.787	M18	0.0	
1910 50540165	-165	1	1.250	2.874	2.750	6.496	4.724	—	0.787	M18	6.3	

1. Use 2 piezas de los tornillos Allen M4 x 5 (S) para cerrar los orificios vacíos en el portaherramienta cuando se use el refrigerante interno.
2. Al hacer su orden, indique el número de llaves inglesas que requiere. Las llaves inglesas "gratuitas" están limitadas al número de portaherramientas de fresado en su orden.
3. La tolerancia del zanco de las herramientas de corte debe ser de h7.

1. Use 2 pcs. of M4 x 5 (S) hex. screw to close air holes on the holder when internal coolant is used.
2. When ordering, indicate number of spanners required. "No charge" spanners are limited to number of milling chucks on order.
3. Tolerance of cutting tool shank must be h7.

Sin boquilla MC
Without MC colletUnidad : Pulgadas
Unit : InchCon boquilla MC
With MC colletUnidad : Pulgada
Unit : Inch

D.I. del portaherramienta de fresado I.D. of Milling Chuck	Longitud mín de inserción Min. chucking length
0.750"	1.575" (40mm)
1.000", 1.250"	1.969" (50mm)
2.000"	2.170" (55mm)

D.I. de la boquilla Collet I.D.	Longitud mín de inserción Min. chucking length
MC, MC-C, MC-OH	
1/4, 5/16	1.181" (30mm)
3/8, 1/2	1.575" (40mm)
5/8, 3/4, 7/8	1.772" (45mm)
1, 1-1/4, 1-1/2	1.969" (50mm)

Medidas Métricas - Metric Sizes

Unidad : Pulgadas
Unit : Inch

Código Code	Modelo Model	Tipo Type	d (mm)	D	D1	L	ℓ	ℓ1	ℓ2	G P=1.0	Kg	Llave Inglesa Spanner
1910 40416090	CAT40 -CT16SA -90	1	16	1.772	1.750	3.543	2.559	—	0.787	M10	1.5	HS-1-16
1910 40420090	CAT40 -CT20SA -90	1	20	2.047	1.750	3.543	3.150	—	0.591	M12	1.7	HS-2-20
1910 40420105	-105	1	20	2.047	1.750	4.134	3.150	—	0.591	M12	1.9	
1910 40420120	-120	1	20	2.047	1.750	4.724	3.150	—	0.591	M12	2.1	
1910 40425105	CAT40 -CT25SA -105	1	25	2.402	1.750	4.134	3.150	—	0.591	M12	2.2	HS-2.5-25
1910 40425120	-120	1	25	2.402	1.750	4.724	3.150	—	0.591	M12	2.5	
1910 40425135	-135	1	25	2.402	1.750	5.315	3.150	—	0.591	M12	2.8	
1910 40432105	CAT40 -CT32SA -105	2	32	2.874	1.750	4.134	3.346	0.906	0.787	M18	2.5	HS-3-32
1910 40432120	-120	2	32	2.874	1.750	4.724	3.346	0.906	0.787	M18	3.0	
1910 40432135	-135	2	32	2.874	1.750	5.315	4.724	—	0.787	M18	3.4	
1910 40516090	CAT50 -CT16SA -90	1	16	1.772	2.750	3.543	2.559	—	0.787	M10	-	HS-1-16
1910 40516105	-105	1	16	1.772	2.750	4.134	2.559	—	0.787	M10	3.7	
1910 40520090	CAT50 -CT20SA -90	1	20	2.047	2.750	3.543	3.150	—	0.591	M12	-	HS-2-20
1910 40520105	-105	1	20	2.047	2.750	4.134	3.150	—	0.591	M12	3.9	
1910 40520135	-135	1	20	2.047	2.750	5.315	3.150	—	0.591	M12	4.3	
1910 40525105	CAT50 -CT25SA -105	1	25	2.402	2.750	4.134	3.150	—	0.591	M12	4.2	HS-2.5-25
1910 40525135	-135	1	25	2.402	2.750	5.315	3.150	—	0.591	M12	4.8	
1910 40525165	-165	1	25	2.402	2.750	6.496	3.150	—	0.591	M12	5.3	
1910 40532095	CAT50 -CT32SA -95	1	32	2.874	2.750	3.740	4.724	—	0.787	M18	4.2	HS-3-32
1910 40532105	-105	1	32	2.874	2.750	4.134	4.724	—	0.787	M18	4.5	
1910 40532120	-120	1	32	2.874	2.750	4.724	4.724	—	0.787	M18	4.9	
1910 40532135	-135	1	32	2.874	2.750	5.315	4.724	—	0.787	M18	5.4	
1910 40532150	-150	1	32	2.874	2.750	5.906	4.724	—	0.787	M18	5.8	
1910 40532165	-165	1	32	2.874	2.750	6.496	4.724	—	0.787	M18	6.3	
1910 40542105	CAT50 -CT42SA -105	1	42	3.465	2.750	4.134	4.724	—	0.787	M18	5.0	
1910 40542120	-120	1	42	3.465	2.750	4.724	4.724	—	0.787	M18	5.6	
1910 40542135	-135	1	42	3.465	2.750	5.315	4.724	—	0.787	M18	6.3	
1910 40542150	-150	1	42	3.465	2.750	5.906	4.724	—	0.787	M18	6.9	
1910 40542165	-165	1	42	3.465	2.750	6.496	4.724	—	0.787	M18	7.6	

- Use 2 piezas de los tornillos Allen M4 x 5 (S) para cerrar los orificios vacíos en el portaherramienta cuando se use el refrigerante interno.
 - Al hacer su orden, indique el número de llaves inglesas que requiere. Las llaves inglesas "gratuitas" están limitadas al número de portaherramientas de fresado en su orden.
 - La tolerancia del zanco de las herramientas de corte debe ser de h7.
 - La velocidad permitida varía mucho según la rigidez del husillo en la máquina y del balance de la herramienta de corte. Aumente gradualmente la velocidad a partir de la baja y úselo en la velocidad adecuada.
- Use 2pcs. of M4 x 5 (S) hex. screw to close air holes on the holder when internal coolant is used.
 - When ordering, indicate number of spanners required. "No charge" spanners are limited to number of milling chucks on order.
 - Tolerance of cutting tool shank must be h7.
 - Permissible speed is greatly affected by the stiffness of the machine spindle and the balance of the cutting tool. Gradually increase from a low speed, and use at the proper speed.

Ejemplo para Ordenar - Ordering Example

CAT40 - CT 0750 SA - 90

Interfaz y diámetro de husillo	Diámetro Interior	Longitud de Proyección
Shank size	I.D. (d)	Projection length (L)

Ejemplo para Ordenar - Ordering Example

CAT40 - CT 16 SA - 90

Interfaz y diámetro de husillo	Diámetro Interior	Longitud de Proyección
Shank size	I.D. (d)	Projection length (L)

Llave Inglesa Spanner
Pág. 073



Accesorios Accessories

Tornillo de retención
Stopper Bolt 
BL (Pág.072)

Boquilla recta
Straight Collet 
MC (Pág.070) | MCA (Pág.071)

Adaptador Morse
Morse Taper Adapter 
MA (Pág.072) | MAB (Pág.072)

Adaptador Jacobs
Jacobs Adapter 
JA (Pág.073) | JAB (Pág.073)

Longitud Mínima de inserción Min. chucking length

D.I. del portaherramienta de fresado I.D. of Milling Chuck	Longitud mín de inserción Min. chucking length
16, 20	40
25, 32, 42	50

Con boquilla MC - With MC collet

D.I. de la boquilla Collet I.D.	Longitud mín de inserción Min. chucking length	
	MC	MC-C, MC-OH
6, 8	30	30
10, 12	40	40
16, 20	45	45
25	50	50
32	50	60

High-Precision Collet Holder

- Adecuado para barrenado, rima y acabado en fresa.
- Suitable for drilling, reaming and finish endmilling.

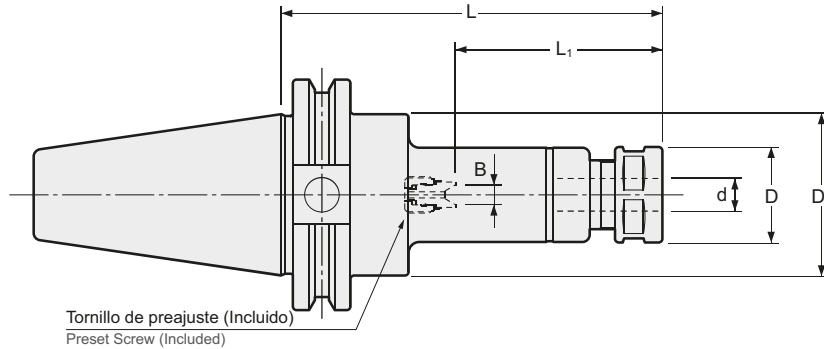

Unidad : Pulgadas
Unit : Inch

Código Code	Modelo Model	d	L	L1	B	D	D1	kg	Tornillo de preajuste Preset Screw	Tuerca ciega Nut	Boquilla Collet	Llave Inglesa Spanner
1990 10407075	CAT40 -HDC07A -75	0.020-0.276	2.953	0.866-1.654	0.0-0.157	0.906	1.750					
1990 10407090	-90	0.020-0.276	3.543	0.866-1.654	0.0-0.157	0.906	1.750		HDS-07	HDP-07A	FDC-07	S-0
1990 10407105	-105	0.020-0.276	4.134	0.866-1.654	0.0-0.157	0.906	1.750					
1990 10409090	CAT40 -HDC09A -90	0.098-0.354	3.543	1.063-2.126	0.0-0.157	1.024	1.750					
1990 10409105	-105	0.098-0.354	4.134	1.063-2.126	0.0-0.157	1.024	1.750		HDS-09	HDP-09	FDC-09	S-1L
1990 10409120	-120	0.098-0.354	4.724	1.063-2.126	0.0-0.157	1.024	1.750					
1990 10409135	-135	0.098-0.354	5.315	1.063-2.126	0.0-0.157	1.024	1.750					
1990 10409165	-165	0.098-0.354	6.496	1.063-2.126	0.0-0.157	1.024	1.750					
1990 10412090	CAT40 -HDC12A -90	0.098-0.472	3.543	1.339-2.598	0.0-0.236	1.260	1.750					
1990 10412105	-105	0.098-0.472	4.134	1.339-2.598	0.0-0.236	1.260	1.750		HDS-12	HDP-12	FDC-12	S-3L
1990 10412120	-120	0.098-0.472	4.724	1.339-2.598	0.0-0.236	1.260	1.750					
1990 10412135	-135	0.098-0.472	5.315	1.339-2.598	0.0-0.236	1.260	1.750					
1990 10412165	-165	0.098-0.472	6.496	1.339-2.598	0.0-0.236	1.260	1.750					
1990 10412195	-195	0.098-0.472	7.677	1.339-2.598	0.0-0.236	1.260	1.750					
1990 10416090	CAT40 -HDC16A -90	0.138-0.630	3.543	1.575-3.071	0.0-0.315	1.417	1.750					
1990 10416105	-105	0.138-0.630	4.134	1.575-3.071	0.0-0.315	1.417	1.750		HDS-16	HDP-16	FDC-16	S-4L
1990 10416120	-120	0.138-0.630	4.724	1.575-3.071	0.0-0.315	1.417	1.750					
1990 10416135	-135	0.138-0.630	5.315	1.575-3.071	0.0-0.315	1.417	1.750					
1990 10416165	-165	0.138-0.630	6.496	1.575-3.071	0.0-0.315	1.417	1.750					
1990 10416195	-195	0.138-0.630	7.677	1.575-3.071	0.0-0.315	1.417	1.750					
1990 10422105	CAT40 -HDC22A -105	0.138-0.866	4.134	1.929-3.898	0.0-0.394	1.811	1.750					
1990 10422120	-120	0.138-0.866	4.724	1.929-3.898	0.0-0.394	1.811	1.750		HDS-22	HDP-22	FDC-22	S-5L
1990 10422135	-135	0.138-0.866	5.315	1.929-3.898	0.0-0.394	1.811	1.750					
1990 10422165	-165	0.138-0.866	6.496	1.929-3.898	0.0-0.394	1.811	1.750					
1990 10422195	-195	0.138-0.866	7.677	1.929-3.898	0.0-0.394	1.811	1.750					
1990 10507090	CAT50 -HDC07A -90	0.020-0.276	3.543	0.866-1.654	0.0-0.157	0.906	2.750					
1990 10507105	-105	0.020-0.276	4.134	0.866-1.654	0.0-0.157	0.906	2.750		HDS-07	HDP-07A	FDC-07	S-0
1990 10507120	-120	0.020-0.276	4.724	0.866-1.654	0.0-0.157	0.906	2.750	3.2				
1990 10507135	-135	0.020-0.276	5.315	0.866-1.654	0.0-0.157	0.906	2.750	3.2				
1990 10507165	-165	0.020-0.276	6.496	0.866-1.654	0.0-0.157	0.906	2.750					
1990 10507195	-195	0.020-0.276	7.677	0.866-1.654	0.0-0.157	0.906	2.750					
1990 10509090	CAT50 -HDC09A -90	0.098-0.354	3.543	1.063-2.126	0.0-0.157	1.024	2.750					
1990 10509105	-105	0.098-0.354	4.134	1.063-2.126	0.0-0.157	1.024	2.750	3.2	HDS-09	HDP-09	FDC-09	S-1L
1990 10509120	-120	0.098-0.354	4.724	1.063-2.126	0.0-0.157	1.024	2.750	3.2				
1990 10509135	-135	0.098-0.354	5.315	1.063-2.126	0.0-0.157	1.024	2.750	3.3				
1990 10509165	-165	0.098-0.354	6.496	1.063-2.126	0.0-0.157	1.024	2.750					
1990 10509195	-195	0.098-0.354	7.677	1.063-2.126	0.0-0.157	1.024	2.750					
1990 10509225	-225	0.098-0.354	8.858	1.063-2.126	0.0-0.157	1.024	2.750					
1990 10509255	-255	0.098-0.354	10.039	1.063-2.126	0.0-0.157	1.024	2.750					

Código Code	Modelo Model	d	L	L1	B	D	D1	kg	Tornillo de preajuste Preset Screw	Tuerca ciega Nut	Boquilla Collet	Llave Inglesa Spanner
1990 10512090	CAT50 -HDC12A -90	0.098-0.472	3.543	1.339-2.598	0.0-0.236	1.260	2.750	3.3	HDS-12	HDP-12	FDC-12	S-3L
1990 10512105	-105	0.098-0.472	4.134	1.339-2.598	0.0-0.236	1.260	2.750	3.3				
1990 10512120	-120	0.098-0.472	4.724	1.339-2.598	0.0-0.236	1.260	2.750	3.4				
1990 10512135	-135	0.098-0.472	5.315	1.339-2.598	0.0-0.236	1.260	2.750	3.4				
1990 10512165	-165	0.098-0.472	6.496	1.339-2.598	0.0-0.236	1.260	2.750	3.7				
1990 10512195	-195	0.098-0.472	7.677	1.339-2.598	0.0-0.236	1.260	2.750	3.7				
1990 10512225	-225	0.098-0.472	8.858	1.339-2.598	0.0-0.236	1.260	2.750	3.7				
1990 10512255	-255	0.098-0.472	10.039	1.339-2.598	0.0-0.236	1.260	2.750	3.7				
1990 10516090	CAT50 -HDC16A -90	0.138-0.630	3.543	1.575-3.071	0.0-0.315	1.417	2.750	3.3	HDS-16	HDP-16	FDC-16	S-4L
1990 10516105	-105	0.138-0.630	4.134	1.575-3.071	0.0-0.315	1.417	2.750	3.4				
1990 10516120	-120	0.138-0.630	4.724	1.575-3.071	0.0-0.315	1.417	2.750	3.5				
1990 10516135	-135	0.138-0.630	5.315	1.575-3.071	0.0-0.315	1.417	2.750	3.5				
1990 10516165	-165	0.138-0.630	6.496	1.575-3.071	0.0-0.315	1.417	2.750	3.7				
1990 10516195	-195	0.138-0.630	7.677	1.575-3.071	0.0-0.315	1.417	2.750	3.9				
1990 10516225	-225	0.138-0.630	8.858	1.575-3.071	0.0-0.315	1.417	2.750	4.1				
1990 10516255	-255	0.138-0.630	10.039	1.575-3.071	0.0-0.315	1.417	2.750	4.3				
1990 10522105	CAT50 -HDC22A -105	0.138-0.866	4.134	1.929-3.898	0.0-0.394	1.811	2.750	3.5	HDS-22	HDP-22	FDC-22	S-5L
1990 10522120	-120	0.138-0.866	4.724	1.929-3.898	0.0-0.394	1.811	2.750	3.7				
1990 10522135	-135	0.138-0.866	5.315	1.929-3.898	0.0-0.394	1.811	2.750	3.8				
1990 10522150	-150	0.138-0.866	5.906	1.929-3.898	0.0-0.394	1.811	2.750	4				
1990 10522165	-165	0.138-0.866	6.496	1.929-3.898	0.0-0.394	1.811	2.750	4.1				
1990 10522195	-195	0.138-0.866	7.677	1.929-3.898	0.0-0.394	1.811	2.750	4.4				
1990 10522225	-225	0.138-0.866	8.858	1.929-3.898	0.0-0.394	1.811	2.750	4.4				
1990 10522255	-255	0.138-0.866	10.039	1.929-3.898	0.0-0.394	1.811	2.750	4.4				

1. La boquilla, llave inglesa, tornillo Allen opresor de preajuste y el tornillo de preajuste para procesos semisecos se venden por separado. El tornillo estándar de preajuste está incluido.
2. Consulte la pág.096 para conocer la longitud mínima para insertar herramientas en caso de usar nuestras boquillas refrigerantes (OH, C o MS).
- 3.L1 indica la dimensión al usarlo con un tornillo de preajuste.
- 4.Consulte la pág. 521 para conocer el Torque recomendado en nuestros productos.
- 5.Incluye el tornillo estándar de preajuste.

- 1.Collet, spanner, hexagon head preset screw, preset screw for semi-dry processing are sold separately. Standard preset screw is included.
- 2.Refer to P.096 for minimum tool insertion length in case of using our coolant collets (OH,C or MS).
- 3.L1 indicates dimension when using with a preset screw.
- 4.See P.521 for standard Tightening Torque.
- 5.Standard preset screw is included.

Boquilla Collet Pág.090-093 	Llave Inglesa Spanner Pág.099 	Tornillo de preajuste Preset screw Pág.098 
--	--	---

Ejemplo para Ordenar - Ordering Example

CAT40 - HDC 09 A - 105

Interfaz y diámetro de husillo Shank size	Máx. Diámetro Interno de boquilla Max. collet I.D.	Longitud de proyección Projection length (L)
--	---	---

Drill Holder With Easy Tool Length Adjustment

- La longitud de proyección de la herramienta de corte se puede ajustar simplemente girando la circunferencia del portaherramienta.
- Projection length of the cutting tool can be adjusted by simply turning circumference of the holder.

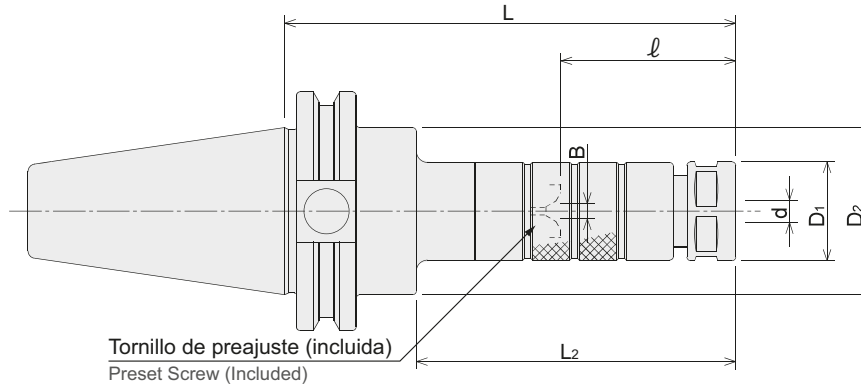

Unidad : Pulgadas
Unit : Inch

Código Code	Modelo Model	d (mm)	L	L2	ℓ	B (mm)	D1	D2	kg	Tuerca ciega Nut	Boquilla Collet	Llave Inglesa Spanner
—	CAT40 -SDM07 -90 (*1)	0.5-7.0	3.543	2.165	1.142-1.535	0-4	0.906	1.750		HDP-07A		
1870 00407105	-105	0.5-7.0	4.134	2.756	1.142-2.126	0-4	0.906	1.750	1.1	HDP-07A	FDC-07	S-0
1870 00407120	-120	0.5-7.0	4.724	3.346	1.142-2.126	0-4	0.906	1.750	1.2	HDP-07A		
1870 00407135	-135	0.5-7.0	5.315	3.937	1.142-2.126	0-4	0.906	1.750	11.9	HDP-07A		
—	-150 (*1)	0.5-7.0	5.906	4.528	1.142-2.126	0-4	0.906	1.750		HDP-07A		
—	CAT40 -SDM09 -90 (*1)	2.5-9.0	3.543	2.165	1.102-1.496	0-4	1.024	1.750		HDP-09	FDC-09	S-1L
1870 00409105	-105	2.5-9.0	4.134	2.756	1.102-2.087	0-4	1.024	1.750	1.2	HDP-09		
1870 00409120	-120	2.5-9.0	4.724	3.346	1.102-2.087	0-4	1.024	1.750	1.2	HDP-09		
1870 00409135	-135	2.5-9.0	5.315	3.937	1.102-2.087	0-4	1.024	1.750	1.3	HDP-09		
—	-150 (*1)	2.5-9.0	5.906	4.528	1.102-2.087	0-4	1.024	1.750		HDP-09		
—	-180 (*1)	2.5-9.0	7.087	5.709	1.102-2.087	0-4	1.024	1.750		HDP-09		
1870 00412105	CAT40 -SDM12 -105	2.5-12.0	4.134	2.756	1.339-2.323	0-5	1.260	1.750	1.3	HDP-12	FDC-12	S-3L
1870 00412120	-120	2.5-12.0	4.724	3.346	1.339-2.323	0-5	1.260	1.750	1.3	HDP-12		
1870 00412135	-135	2.5-12.0	5.315	3.937	1.339-2.323	0-5	1.260	1.750	1.4	HDP-12		
—	-150 (*1)	2.5-12.0	5.906	4.528	1.339-2.323	0-5	1.260	1.750		HDP-12		
—	-180 (*1)	2.5-12.0	7.087	5.709	1.339-2.323	0-5	1.260	1.750		HDP-12		
1870 00416105	CAT40 -SDM16 -105	3.5-16.0	4.134	2.756	1.575-1.969	0-6	1.417	1.750	1.3	HDP-16	FDC-16	S-4L
1870 00416120	-120	3.5-16.0	4.724	3.346	1.575-2.559	0-6	1.417	1.750	1.4	HDP-16		
1870 00416135	-135	3.5-16.0	5.315	3.937	1.575-2.559	0-6	1.417	1.750	1.5	HDP-16		
—	-150 (*1)	3.5-16.0	5.906	4.528	1.575-2.559	0-6	1.417	1.750		HDP-16		
—	-180 (*1)	3.5-16.0	7.087	5.709	1.575-2.559	0-6	1.417	1.750		HDP-16		
1870 00422120	CAT40 -SDM22 -120	3.5-22.0	4.724	3.346	1.890-2.283	0-8	1.811	1.750	1.6	HDP-22	FDC-22	S-5L
1870 00422135	-135	3.5-22.0	5.315	3.937	1.890-2.874	0-8	1.811	1.750	1.7	HDP-22		
1870 00422150	-150	3.5-22.0	5.906	4.528	1.890-2.874	0-8	1.811	1.750	1.9	HDP-22		
—	-180 (*1)	3.5-22.0	7.087	5.709	1.890-2.874	0-8	1.811	1.750		HDP-22		
—	CAT50 -SDM07 -90 (*1)	0.5-7.0	3.543	2.165	1.142-1.535	0-4	0.906	2.750		HDP-07A	FDC-07	S-0
1870 00507105	-105	0.5-7.0	4.134	2.756	1.142-2.126	0-4	0.906	2.750		HDP-07A		
1870 00507120	-120	0.5-7.0	4.724	3.346	1.142-2.126	0-4	0.906	2.750		HDP-07A		
1870 00507135	-135	0.5-7.0	5.315	3.937	1.142-2.126	0-4	0.906	2.750		HDP-07A		
—	-150 (*1)	0.5-7.0	5.906	4.528	1.142-2.126	0-4	0.906	2.750		HDP-07A		
—	-165 (*1)	0.5-7.0	6.496	5.118	1.142-2.126	0-4	0.906	2.750		HDP-07A		

1. La boquilla y la llave inglesa se venden por separado.
2. ℓ es la dimensión entre el cabezal de tuerca y el extremo superior del tornillo de preajuste.
3. Consulte la pág. 521 para conocer el Torque estándar de apriete.
4. (*1): SEMI-ESTÁNDAR

1. Collet and spanner are sold separately.
2. ℓ is the dimension between the cap end and the preset screw top end.
3. See P.521 for standard Tightening Torque.
4. (*1) : SEMI-STANDARD

Unidad : Pulgadas
Unit : Inch

Código Code	Modelo Model	d (mm)	L	L2	ℓ	B (mm)	D1	D2	kg	Tuerca ciega Nut	Boquilla Collet	Llave Inglesa Spanner
—	CAT50 -SDM09 -90 (*1)	2.5-9.0	3.543	2.165	1.102-1.496	0-4	1.024	2.750		HDP-09	FDC-09	S-1L
1870 00509105	-105	2.5-9.0	4.134	2.756	1.102-2.087	0-4	1.024	2.750		HDP-09		
1870 00509120	-120	2.5-9.0	4.724	3.346	1.102-2.087	0-4	1.024	2.750		HDP-09		
1870 00509135	-135	2.5-9.0	5.315	3.937	1.102-2.087	0-4	1.024	2.750		HDP-09		
—	-150 (*1)	2.5-9.0	5.906	4.528	1.102-2.087	0-4	1.024	2.750		HDP-09		
—	-180 (*1)	2.5-9.0	7.087	5.709	1.102-2.087	0-4	1.024	2.750		HDP-09		
1870 00512105	CAT50 -SDM12 -105	2.5-12.0	4.134	2.756	1.339-1.732	0-5	1.260	2.750		HDP-12	FDC-12	S-3L
1870 00512120	-120	2.5-12.0	4.724	3.346	1.339-2.323	0-5	1.260	2.750		HDP-12		
1870 00512135	-135	2.5-12.0	5.315	3.937	1.339-2.323	0-5	1.260	2.750		HDP-12		
—	-150 (*1)	2.5-12.0	5.906	4.528	1.339-2.323	0-5	1.260	2.750		HDP-12		
—	-180 (*1)	2.5-12.0	7.087	5.709	1.339-2.323	0-5	1.260	2.750		HDP-12		
1870 00516105	CAT50 -SDM16 -105	3.5-16.0	4.134	2.756	1.575-1.969	0-6	1.417	2.750		HDP-16		
1870 00516120	-120	3.5-16.0	4.724	3.346	1.575-2.559	0-6	1.417	2.750		HDP-16		
1870 00516135	-135	3.5-16.0	5.315	3.937	1.575-2.559	0-6	1.417	2.750		HDP-16		
1870 00516150	-150	3.5-16.0	5.906	4.528	1.575-2.559	0-6	1.417	2.750		HDP-16		
—	-180 (*1)	3.5-16.0	7.087	5.709	1.575-2.559	0-6	1.417	2.750		HDP-16		
1870 00522120	CAT50 -SDM22 -120	3.5-22.0	4.724	3.346	1.890-2.283	0-8	1.811	2.750		HDP-22	FDC-22	S-5L
1870 00522135	-135	3.5-22.0	5.315	3.937	1.890-2.874	0-8	1.811	2.750		HDP-22		
1870 00522150	-150	3.5-22.0	5.906	4.528	1.890-2.874	0-8	1.811	2.750		HDP-22		
1870 00522180	-180	3.5-22.0	7.087	5.709	1.890-2.874	0-8	1.811	2.750		HDP-22		
—	-210 (*1)	3.5-22.0	8.268	6.89	1.890-2.874	0-8	1.811	2.750		HDP-22		

1. La boquilla y la llave inglesa se venden por separado.
2. ℓ es la dimensión entre el cabezal de la tuerca y el extremo superior del tornillo de preajuste.
3. Consulte la pág. 521 para conocer el Torque estándar de ajuste.
4. (*1): SEMI-ESTÁNDAR

1. Collet and spanner are sold separately.
2. ℓ is the dimension between the cap end and the preset screw top end.
3. See P.521 for standard Tightening Torque.
4. (*1) : SEMI-STANDARD

Boquilla Collet
Pág.090-093



Llave Inglesa Spanner
Pág.099



Ejemplo para Ordenar - Ordering Example

CAT40	-	SDM		12	-	90
Interfaz y diámetro de husillo				Máx. Diámetro Interno de boquilla		Longitud de proyección
Shank size				Max. collet I.D.		Projection length (L)

CAT

BT

CAT

AHO

HSK-A/E/F/C

HSK-T

C

UTS

Máquinas Especializadas

Specialized Machine

Equipo Relacionado

Related Equipment

Taladro de Biselado & de Casquillo

Bush & Chamfering Drill

High-Precision Collet Holder (High-Balanced Type)

- Adecuado para barrenado con rotación a alta velocidad, rima y acabado en fresa.
- Suitable for high speed rotation drilling, reaming, and finish endmilling.

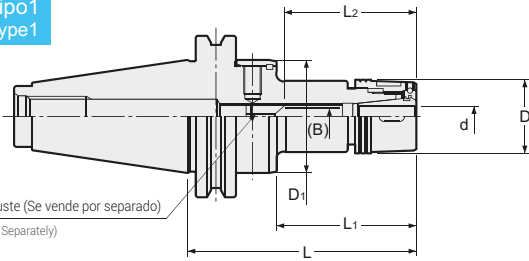
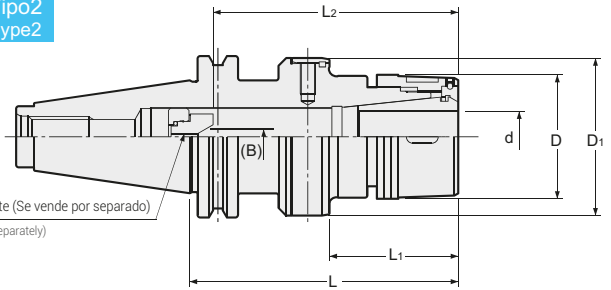
Tipo1
Type1Tipo2
Type2

Unidad : Pulgadas
Unit : Inch

Código Code	Modelo Model	Tipo Type	d	L	L1	(B)	L2	D	D1	kg	Tornillo de preajuste Preset Screw	Tuerca ciega Nut	Boquilla Collet	Llave Inglesa Spanner
1970 00407090	CAT40 -GDC07A -90	1	0.020 -0.276	3.543	2.165	0.0 -0.157	0.866 -1.772	0.906	1.750	1.1	HDS-07	HDP-07A	FDC-07AA	S-0
1970 00407120	-120	1	0.020 -0.276	4.724	3.346	0.0 -0.157	0.866 -1.772	0.906	1.750					
1970 00409090	CAT40 -GDC09A -90	1	0.098 -0.354	3.543	2.165	0.0 -0.157	1.063 -2.244	1.142	1.750	1.2	HDS-09	GDP-09	FDC-09AA	S-0
1970 00409120	-120	1	0.098 -0.354	4.724	3.346	0.0 -0.157	1.063 -2.244	1.142	1.750	1.3				
1970 00412105	CAT40 -GDC12A -105	1	0.098 -0.472	4.134	2.756	0.0 -0.197	1.299 -2.677	1.339	1.750		HDS-12	GDP-12	FDC-12AA	FK-0030
1970 00412135	-135	1	0.098 -0.472	5.315	3.937	0.0 -0.197	1.299 -2.677	1.339	1.750					
1970 00416105	CAT40 -GDC16A -105	1	0.138 -0.630	4.134	2.756	0.0 -0.236	1.496 -3.189	1.496	1.750	1.4	HDS-16	GDP-16	FDC-16AA	FK-0034
1970 00416135	-135	1	0.138 -0.630	5.315	3.937	0.0 -0.236	1.496 -3.189	1.496	1.750					
1970 00422105	CAT40 -GDC22A -105	2	0.138 -0.866	4.134	1.969	0.0 -0.315	1.850 -4.055	1.929	2.441		HDS-22	GDP-22	FDC-22AA	FK-0045
1970 00422135	-135	2	0.138 -0.866	5.315	3.150	0.0 -0.315	1.850 -4.055	1.929	2.441					
1970 00507105	CAT50 -GDC07A -105	1	0.020 -0.276	4.134	2.756	0.0 -0.157	0.866 -1.772	0.906	2.750		HDS-07	HDP-07A	FDC-07AA	S-0
1970 00507135	-135	1	0.020 -0.276	5.315	3.937	0.0 -0.157	0.866 -1.772	0.906	2.750					
1970 00509105	CAT50 -GDC09A -105	1	0.098 -0.354	4.134	2.756	0.0 -0.157	1.063 -2.244	1.142	2.750		HDS-09	GDP-09	FDC-09AA	S-0
1970 00509135	-135	1	0.098 -0.354	5.315	3.937	0.0 -0.157	1.063 -2.244	1.142	2.750					
1970 00512105	CAT50 -GDC12A -105	1	0.098 -0.472	4.134	2.756	0.0 -0.197	1.299 -2.677	1.339	2.750		HDS-12	GDP-12	FDC-12AA	FK-0030
1970 00512135	-135	1	0.098 -0.472	5.315	3.937	0.0 -0.197	1.299 -2.677	1.339	2.750					
1970 00516105	CAT50 -GDC16A -105	1	0.138 -0.630	4.134	2.756	0.0 -0.236	1.496 -3.189	1.496	2.750		HDS-16	GDP-16	FDC-16AA	FK-0034
1970 00516135	-135	1	0.138 -0.630	5.315	3.937	0.0 -0.236	1.496 -3.189	1.496	2.750	3.5				
1970 00522105	CAT50 -GDC22A -105	1	0.138 -0.866	4.134	2.756	0.0 -0.315	1.850 -4.055	1.929	2.750		HDS-22	GDP-22	FDC-22AA	FK-0045
1970 00522135	-135	1	0.138 -0.866	5.315	3.937	0.0 -0.315	1.850 -4.055	1.929	2.750					

1. La boquilla, el tornillo de preajuste y la llave inglesa se venden por separado.
 2. Siempre use boquillas de categoría "AA".
 3. Consulte la pág. 096 para conocer la longitud mínima para insertar herramientas en caso de usar nuestras boquillas refrigerantes (OH, C o MS).
 4. L2 indica la dimensión cuando se use con un tornillo de preajuste.
 5. Consulte la pág. 521 para conocer el Torque recomendado para nuestros productos.
1. Collet, preset screw and spanner are sold separately.
 2. Always use "AA" class collet.
 3. Refer to P. 096 for minimum tool insertion length in case of using our coolant collets (OH,C or MS).
 4. L2 indicates dimension when using with a preset screw.
 5. See P.521 for standard Tightening Torque.



Ejemplo para Ordenar - Ordering Example

CAT40 - GDC 09 A - 90

Interfaz y diámetro de husillo
Shank size

Máx. Diámetro Interno de boquilla
Max. collet I.D.

Longitud de proyección
Projection length (L)

Collet Holder For Small Diameters

- Para barrenado en espacios angostos.
- For drilling in tight space.

Tipo 1
Type 1

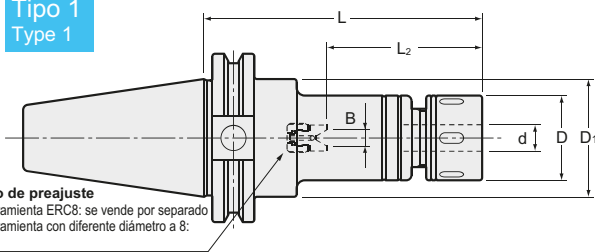

Tornillo de preajuste
Portaherramienta ERC8: se vende por separado
Portaherramienta con diferente diámetro a 8: incluido
Preset Screw
ERC8 Holder : Sold separately
Other Holder : Included

Tipo 2
Type 2

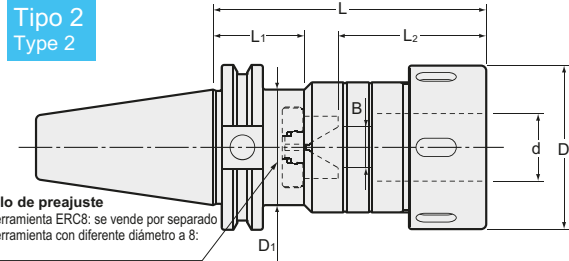

Tornillo de preajuste
Portaherramienta ERC8: se vende por separado
Portaherramienta con diferente diámetro a 8: incluido
Preset Screw
ERC8 Holder : Sold separately
Other Holder : Included

Unidad : Pulgadas
Unit : Inch

Código Code	Modelo Model	Tipo Type	d	L	L1	B	L2	D	D1	kg	Tornillo de preajuste Preset Screw	Tuerca ciega Nut	Boquilla Collet	Llave Inglesa Spanner
1980 00408075	CAT40-ERC 8 -75	1	0.020-0.197	2.953	—	— (0~0.094)	1.299 (0.748~1.220)	0.472	1.750	1.0	—	ERP-8	ER8	S-8E
1980 00408105	-105	1	0.020-0.197	4.134	—	— (0~0.094)	1.299 (0.748~1.220)	0.472	1.750	1.1	—	ERP-8	ER8	S-8E
1980 00410075	CAT40-ERC11S -75	1	0.020-0.276	2.953	—	0.0-0.157	0.866-1.654	0.630	1.750	1.1	HDS07A-ES11	ERP-11S	ER11	S-11E
1980 00410105	-105	1	0.020-0.276	4.134	—	0.0-0.157	0.866-1.654	0.630	1.750	1.1		HDP-07A		S-0
1980 00411075	CAT40-ERC11 -75	1	0.020-0.276	2.953	—	0.0-0.157	0.866-1.654	0.906	1.750	1.1	HDS07A-ES11	HDP-07A	ER11	S-0
1980 00411090	-90	1	0.020-0.276	3.543	—	0.0-0.157	0.866-1.654	0.906	1.750	1.1				
1980 00411105	-105	1	0.020-0.276	4.134	—	0.0-0.157	0.866-1.654	0.906	1.750	1.2	ES16	ERP-16	ER16	FK-0030
1980 00416090	CAT40-ERC16 -90	1	0.020-0.394	3.543	—	0.0-0.197	1.299-2.126	1.260	1.750	1.3				
1980 00416105	-105	1	0.020-0.394	4.134	—	0.0-0.197	1.299-2.126	1.260	1.750	1.3	ES16	ERP-16	ER16	FK-0030
1980 00416120	-120	1	0.020-0.394	4.724	—	0.0-0.197	1.299-2.126	1.260	1.750	1.4				
1980 00416135	-135	1	0.020-0.394	5.315	—	0.0-0.197	1.299-2.126	1.260	1.750	1.5	HDS12A-ES20	ERP-20	ER20	FK-0034
1980 00416165	-165	1	0.020-0.394	6.496	—	0.0-0.197	1.299-2.126	1.260	1.750	1.5				
1980 00420090	CAT40-ERC20 -90	1	0.020-0.512	3.543	—	0.0-0.236	1.496-2.638	1.378	1.750	1.3	HDS12A-ES20	ERP-20	ER20	FK-0034
1980 00420105	-105	1	0.020-0.512	4.134	—	0.0-0.236	1.496-2.638	1.378	1.750	1.3				
1980 00420120	-120	1	0.020-0.512	4.724	—	0.0-0.236	1.496-2.638	1.378	1.750	1.3	HDS12A-ES20	ERP-20	ER20	FK-0034
1980 00420135	-135	1	0.020-0.512	5.315	—	0.0-0.236	1.496-2.638	1.378	1.750	1.3				
1980 00420165	-165	1	0.020-0.512	6.496	—	0.0-0.236	1.496-2.638	1.378	1.750	1.3	HDS12A-ES20	ERP-20	ER20	FK-0034
1980 00420195	-195	1	0.020-0.512	7.677	—	0.0-0.236	1.496-2.638	1.378	1.750	1.3				
1980 00425090	CAT40-ERC25 -90	1	0.020-0.630	3.543	—	0.0-0.315	1.693-3.150	1.654	1.750	1.4	HDS16A-ES25	ERP-25	ER25	HS-1-16
1980 00425105	-105	1	0.020-0.630	4.134	—	0.0-0.315	1.693-3.150	1.654	1.750	1.5				
1980 00425120	-120	1	0.020-0.630	4.724	—	0.0-0.315	1.693-3.150	1.654	1.750	1.7	HDS16A-ES25	ERP-25	ER25	HS-1-16
1980 00425135	-135	1	0.020-0.630	5.315	—	0.0-0.315	1.693-3.150	1.654	1.750	1.7				
1980 00425165	-165	1	0.020-0.630	6.496	—	0.0-0.315	1.693-3.150	1.654	1.750	1.7	HDS16A-ES25	ERP-25	ER25	HS-1-16
1980 00425195	-195	1	0.020-0.630	7.677	—	0.0-0.315	1.693-3.150	1.654	1.750	1.7				
1980 00432105	CAT40-ERC32 -105	1	0.098-0.787	4.134	—	0.0-0.394	1.969-3.976	1.969	1.750	1.5	HDS22A-ES32	ERP-32	ER32	HS-2-20
1980 00432120	-120	1	0.098-0.787	4.724	—	0.0-0.394	1.969-3.976	1.969	1.750	1.6				
1980 00432135	-135	1	0.098-0.787	5.315	—	0.0-0.394	1.969-3.976	1.969	1.750	1.8	HDS22A-ES32	ERP-32	ER32	HS-2-20
1980 00432165	-165	1	0.098-0.787	6.496	—	0.0-0.394	1.969-3.976	1.969	1.750	2.1				
1980 00432195	-195	1	0.098-0.787	7.677	—	0.0-0.394	1.969-3.976	1.969	1.750	2.4	HDS22A-ES32	ERP-32	ER32	HS-2-20
1980 00440075	CAT40-ERC40 -75	2	0.118-1.024	2.953	1.380	—	3.386	2.480	1.750	1.2				
1980 00440105	-105	2	0.118-1.024	4.134	1.380	0.0 0.138-0.551	2.362-3.504	2.480	1.750	1.2	ES40	ERP-40	ER40	HS-2.5-25
1980 00440150	-150	2	0.118-1.024	5.906	1.380	0.0 0.138-0.551	2.362-3.898	2.480	1.750	1.2				
1980 00440165	-165	2	0.118-1.024	6.496	1.380	0.0 0.138-0.551	2.362-3.898	2.480	1.750	1.2	ES40	ERP-40	ER40	HS-2.5-25
1980 00511090	CAT50-ERC11 -90	1	0.020-0.276	3.543	—	0.0-0.157	0.866-1.654	0.906	2.750	3.2				
1980 00511105	-105	1	0.020-0.276	4.134	—	0.0-0.157	0.866-1.654	0.906	2.750	3.2	HDS07A-ES11	HDP-07A	ER11	S-0
1980 00511120	-120	1	0.020-0.276	4.724	—	0.0-0.157	0.866-1.654	0.906	2.750	3.2				
1980 00511135	-135	1	0.020-0.276	5.315	—	0.0-0.157	0.866-1.654	0.906	2.750	3.2	HDS07A-ES11	HDP-07A	ER11	S-0
1980 00511165	-165	1	0.020-0.276	6.496	—	0.0-0.157	0.866-1.654	0.906	2.750	3.2				
1980 00511195	-195	1	0.020-0.276	7.677	—	0.0-0.157	0.866-1.654	0.906	2.750	3.2	HDS07A-ES11	HDP-07A	ER11	S-0
1980 00511195	-195	1	0.020-0.276	7.677	—	0.0-0.157	0.866-1.654	0.906	2.750	3.2				

Código Code	Modelo Model	Tipo Type	d	L	L1	B	L2	D	D1	kg	Tornillo de preajuste Preset Screw	Tuerca ciega Nut	Boquilla Collet	Llave Inglesa Spanner	
1980 00516090	CAT50 -ERC16	-90	1	0.020-0.394	3.543	—	0.0-0.197	1.299-2.126	1.260	2.750	3.3	ES16	ERP-16	ER16	FK-0030
1980 00516105		-105	1	0.020-0.394	4.134	—	0.0-0.197	1.299-2.126	1.260	2.750	3.3				
1980 00516120		-120	1	0.020-0.394	4.724	—	0.0-0.197	1.299-2.126	1.260	2.750					
1980 00516135		-135	1	0.020-0.394	5.315	—	0.0-0.197	1.299-2.126	1.260	2.750	3.5				
1980 00516165		-165	1	0.020-0.394	6.496	—	0.0-0.197	1.299-2.126	1.260	2.750					
1980 00516195		-195	1	0.020-0.394	7.677	—	0.0-0.197	1.299-2.126	1.260	2.750					
1980 00516225		-225	1	0.020-0.394	8.858	—	0.0-0.197	1.299-2.126	1.260	2.750					
1980 00516255		-255	1	0.020-0.394	10.039	—	0.0-0.197	1.299-2.126	1.260	2.750					
1980 00520090	CAT50 -ERC20	-90	1	0.020-0.512	3.543	—	0.0-0.236	1.496-2.638	1.378	2.750	HDS12A-ES20	ERP-20	ER20	FK-0034	
1980 00520105		-105	1	0.020-0.512	4.134	—	0.0-0.236	1.496-2.638	1.378	2.750					3.4
1980 00520120		-120	1	0.020-0.512	4.724	—	0.0-0.236	1.496-2.638	1.378	2.750					3.4
1980 00520135		-135	1	0.020-0.512	5.315	—	0.0-0.236	1.496-2.638	1.378	2.750					3.5
1980 00520165		-165	1	0.020-0.512	6.496	—	0.0-0.236	1.496-2.638	1.378	2.750					3.7
1980 00520195		-195	1	0.020-0.512	7.677	—	0.0-0.236	1.496-2.638	1.378	2.750					
1980 00520225		-225	1	0.020-0.512	8.858	—	0.0-0.236	1.496-2.638	1.378	2.750					
1980 00520255		-255	1	0.020-0.512	10.039	—	0.0-0.236	1.496-2.638	1.378	2.750					
1980 00525090	CAT50 -ERC25	-90	1	0.020-0.630	3.543	—	0.0-0.315	1.693-3.150	1.654	2.750	HDS16A-ES25	ERP-25	ER25	HS-1-16	
1980 00525105		-105	1	0.020-0.630	4.134	—	0.0-0.315	1.693-3.150	1.654	2.750					3.5
1980 00525120		-120	1	0.020-0.630	4.724	—	0.0-0.315	1.693-3.150	1.654	2.750					3.7
1980 00525135		-135	1	0.020-0.630	5.315	—	0.0-0.315	1.693-3.150	1.654	2.750					3.8
1980 00525165		-165	1	0.020-0.630	6.496	—	0.0-0.315	1.693-3.150	1.654	2.750					4
1980 00525195		-195	1	0.020-0.630	7.677	—	0.0-0.315	1.693-3.150	1.654	2.750					
1980 00525225		-225	1	0.020-0.630	8.858	—	0.0-0.315	1.693-3.150	1.654	2.750					
1980 00525255		-255	1	0.020-0.630	10.039	—	0.0-0.315	1.693-3.150	1.654	2.750					
1980 00532105	CAT50 -ERC32	-105	1	0.098-0.787	4.134	—	0.0-0.394	1.969-3.976	1.969	2.750	3.7	HDS22A-ES32	ERP-32	ER32	HS-2-20
1980 00532120		-120	1	0.098-0.787	4.724	—	0.0-0.394	1.969-3.976	1.969	2.750	3.8				
1980 00532135		-135	1	0.098-0.787	5.315	—	0.0-0.394	1.969-3.976	1.969	2.750	2				
1980 00532150		-150	1	0.098-0.787	5.906	—	0.0-0.394	1.969-3.976	1.969	2.750					
1980 00532165		-165	1	0.098-0.787	6.496	—	0.0-0.394	1.969-3.976	1.969	2.750					
1980 00532195		-195	1	0.098-0.787	7.677	—	0.0-0.394	1.969-3.976	1.969	2.750					
1980 00532225		-225	1	0.098-0.787	8.858	—	0.0-0.394	1.969-3.976	1.969	2.750					
1980 00532255		-255	1	0.098-0.787	10.039	—	0.0-0.394	1.969-3.976	1.969	2.750					
1980 00540075	CAT50 -ERC40	-75	1	0.118-1.024	2.953	—	0.0 0.138-0.551	2.362-3.701	2.480	2.750	ES40	ERP-40	ER40	HS-2.5-25	
1980 00540105		-105	1	0.118-1.024	4.134	—	0.0 0.138-0.551	2.362-3.898	2.480	2.750					3.9
1980 00540165		-165	1	0.118-1.024	6.496	—	0.0 0.138-0.551	2.362-3.898	2.480	2.750					5.1
1980 00550105	CAT50 -ERC50	-105	1	0.394-1.339	4.134	—	0.0 0.236-0.630	2.913-3.937	3.071	2.750	ES50	ERP-50	ER50	HS-4-42	

1. La boquilla y la llave inglesa se venden por separado.
2. El ES8, un tornillo de preajuste para el ERC8, se vende por separado. El ERC11S incluye un tornillo estándar de preajuste HDS-07A-ES11.
3. Las dimensiones "B" e "L2" entre corchetes sirven para usar el tornillo de preajuste ES8.
4. Consulte la pág. 096 para conocer la longitud mínima para insertar herramientas en caso de usar nuestras boquillas refrigerantes.
5. Consulte la pág. 521 para conocer el Torque recomendado para nuestros productos.

1. Collet and spanner are sold separately.
2. ES8, a preset screw for ERC8, is sold separately. ERC11S includes a standard preset screw HDS-07A-ES11.
3. "B" and "L2" dimensions in brackets are for using ES8 preset screw.
4. Refer to P.096 for minimum tool insertion length in case of using our coolant collets.
5. See P.521 for standard Tightening Torque.

Boquilla Collet Pág. 094-095	Llave Inglesa Spanner Pág. 099	Tornillo de preajuste Preset screw Pág. 098
		

Ejemplo para Ordenar - Ordering Example

CAT40 - ERC 8 - 105

Interfaz y diámetro de husillo

Shank size

Máx. Diámetro Interno de boquilla

Max. collet I.D.

Longitud de proyección

Projection length (L)

"R" Zero Holder

- La precisión de excentricidad del borde de corte puede ajustarse hasta casi cero.
- Runout accuracy of the cutting edge can be adjusted as closely as to zero.

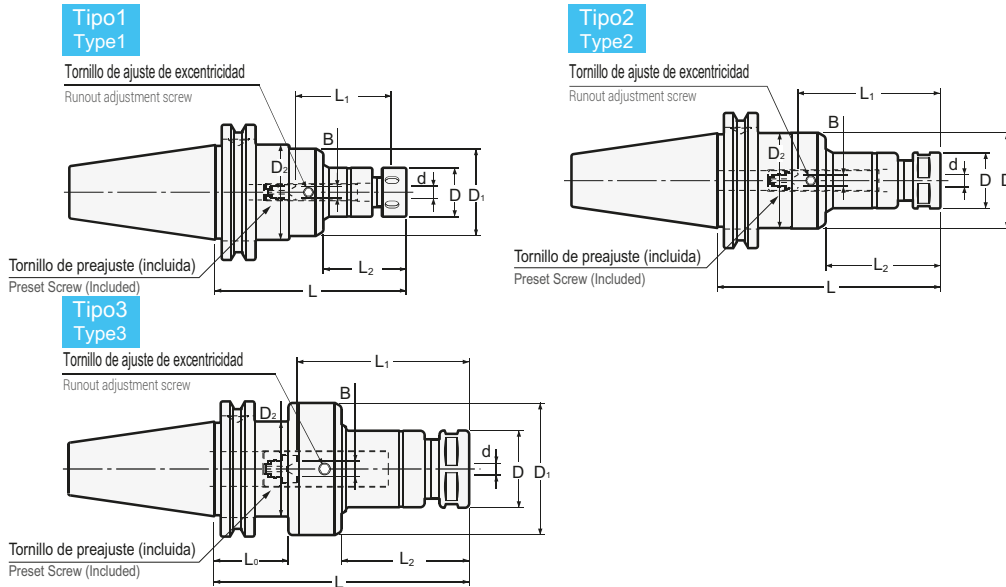





Unidad : Pulgadas
Unit : Inch

Código Code	Modelo Model	Tipo Type	d	L	L1	L2	B	D	D1	L0	D2	kg	Tornillo de preajuste Preset Screw	Tuerca ciega Nut	Llave Inglesa Spanner	Boquilla Collet	Llave Allen Hex. Wrench	
1960 00407090	CAT40-HDZ07	-90	1	0.020-0.276	3.543	0.866-1.772	1.535	0.0-0.157	0.906	1.614	—	1.750						
1960 00407105		-105	1	0.020-0.276	4.134	0.866-1.772	2.126	0.0-0.157	0.906	1.614	—	1.750	HDS-07	HDP-07A	S-0	FDC-07		
1960 00409090	CAT40-HDZ09	-90	2	0.098-0.354	3.543	1.063-2.244	1.535	0.0-0.157	1.024	1.772	—	1.750						
1960 00409105		-105	2	0.098-0.354	4.134	1.063-2.244	2.126	0.0-0.157	1.024	1.772	—	1.750						
1960 00409120		-120	2	0.098-0.354	4.724	1.063-2.244	2.717	0.0-0.157	1.024	1.772	—	1.750	HDS-09	HDP-09	S-1L	FDC-09	L-3T (3mm)	
1960 00409135		-135	2	0.098-0.354	5.315	1.063-2.244	3.307	0.0-0.157	1.024	1.772	—	1.750						
1960 00409165		-165	2	0.098-0.354	6.496	1.063-2.244	4.488	0.0-0.157	1.024	1.772	—	1.750						
1960 00412105	CAT40-HDZ12	-105	3	0.098-0.472	4.134	1.299-2.677	1.772	0.0-0.197	1.260	2.205	1.378	1.750						
1960 00412120		-120	3	0.098-0.472	4.724	1.299-2.677	2.362	0.0-0.197	1.260	2.205	1.378	1.750						
1960 00412135		-135	3	0.098-0.472	5.315	1.299-2.677	2.953	0.0-0.197	1.260	2.205	1.378	1.750	HDS-12	HDP-12	S-3L	FDC-12		
1960 00412165		-165	3	0.098-0.472	6.496	1.299-2.677	4.134	0.0-0.197	1.260	2.205	1.378	1.750						
1960 00412195		-195	3	0.098-0.472	7.677	1.299-2.677	5.315	0.0-0.197	1.260	2.205	1.378	1.750					L-4T (4mm)	
1960 00416105	CAT40-HDZ16	-105	3	0.138-0.630	4.134	1.496-3.189	1.772	0.0-0.236	1.417	2.441	1.378	1.750						
1960 00416120		-120	3	0.138-0.630	4.724	1.496-3.189	2.362	0.0-0.236	1.417	2.441	1.378	1.750						
1960 00416135		-135	3	0.138-0.630	5.315	1.496-3.189	2.953	0.0-0.236	1.417	2.441	1.378	1.750	HDS-16	HDP-16	S-4L	FDC-16		
1960 00416165		-165	3	0.138-0.630	6.496	1.496-3.189	4.134	0.0-0.236	1.417	2.441	1.378	1.750						
1960 00416195		-195	3	0.138-0.630	7.677	1.496-3.189	5.315	0.0-0.236	1.417	2.441	1.378	1.750						
1960 10422105	CAT40-HDZ22-A	-105	3	0.138-0.866	4.134	1.850-4.055	1.024	0.0-0.315	1.811	2.717	1.378	1.750						
1960 10422120		-120	3	0.138-0.866	4.724	1.850-4.055	1.614	0.0-0.315	1.811	2.717	1.378	1.750						
1960 10422135		-135	3	0.138-0.866	5.315	1.850-4.055	2.205	0.0-0.315	1.811	2.717	1.378	1.750	HDS-22	HDP-22	S-5L	FDC-22	L-5T (5mm)	
1960 10422165		-165	3	0.138-0.866	6.496	1.850-4.055	3.386	0.0-0.315	1.811	2.717	1.378	1.750						
1960 10422195		-195	3	0.138-0.866	7.677	1.850-4.055	4.567	0.0-0.315	1.811	2.717	1.378	1.750						
1960 00507090	CAT50-HDZ07	-90	1	0.020-0.276	3.543	0.866-1.772	1.535	0.0-0.157	0.906	1.614	—	2.750						
1960 00507105		-105	1	0.020-0.276	4.134	0.866-1.772	2.126	0.0-0.157	0.906	1.614	—	2.750						
1960 00507120		-120	1	0.020-0.276	4.724	0.866-1.772	2.717	0.0-0.157	0.906	1.614	—	2.750						
1960 00507135		-135	1	0.020-0.276	5.315	0.866-1.772	3.307	0.0-0.157	0.906	1.614	—	2.750	3.3	HDS-07	HDP-07A	S-0	FDC-07	
1960 00507165		-165	1	0.020-0.276	6.496	0.866-1.772	4.291	0.0-0.157	0.906	1.614	—	2.750						
1960 00507195		-195	1	0.020-0.276	7.677	0.866-1.772	5.669	0.0-0.157	0.906	1.614	—	2.750						
1960 00509090	CAT50-HDZ09	-90	1	0.098-0.354	3.543	1.063-2.244	1.378	0.0-0.157	1.024	1.772	—	2.750						
1960 00509105		-105	1	0.098-0.354	4.134	1.063-2.244	1.969	0.0-0.157	1.024	1.772	—	2.750	3.3					
1960 00509120		-120	1	0.098-0.354	4.724	1.063-2.244	2.559	0.0-0.157	1.024	1.772	—	2.750						
1960 00509135		-135	1	0.098-0.354	5.315	1.063-2.244	3.150	0.0-0.157	1.024	1.772	—	2.750	3.4	HDS-09	HDP-09	S-1L	FDC-09	L-3T (3mm)
1960 00509165		-165	1	0.098-0.354	6.496	1.063-2.244	4.331	0.0-0.157	1.024	1.772	—	2.750						
1960 00509195		-195	1	0.098-0.354	7.677	1.063-2.244	5.512	0.0-0.157	1.024	1.772	—	2.750						
1960 00509225		-225	1	0.098-0.354	8.858	1.063-2.244	6.693	0.0-0.157	1.024	1.772	—	2.750						
1960 00509255		-255	1	0.098-0.354	10.039	1.063-2.244	7.874	0.0-0.157	1.024	1.772	—	2.750						

Código Code	Modelo Model	Tipo Type	d	L	L1	L2	B	D	D1	L0	D2	kg	Tornillo de preajuste Preset Screw	Tuerca ciega Nut	Llave Inglesa Spanner	Boquilla Collet	Llave Allen Hex. Wrench
1960 00512090	CAT50-HDZ12	-90	1	0.098-0.472	3.543	1.299-2.677	1.378	0.0-0.197	1.260	2.205	—	2.750					
1960 00512105		-105	1	0.098-0.472	4.134	1.299-2.677	1.969	0.0-0.197	1.260	2.205	—	2.750	3.5				
1960 00512120		-120	1	0.098-0.472	4.724	1.299-2.677	2.559	0.0-0.197	1.260	2.205	—	2.750					
1960 00512135		-135	1	0.098-0.472	5.315	1.299-2.677	3.150	0.0-0.197	1.260	2.205	—	2.750	3.7				
1960 00512165		-165	1	0.098-0.472	6.496	1.299-2.677	4.331	0.0-0.197	1.260	2.205	—	2.750	3.8				
1960 00512195		-195	1	0.098-0.472	7.677	1.299-2.677	5.512	0.0-0.197	1.260	2.205	—	2.750					
1960 00512225		-225	1	0.098-0.472	8.858	1.299-2.677	6.693	0.0-0.197	1.260	2.205	—	2.750	4.1				
1960 00512255		-255	1	0.098-0.472	10.039	1.299-2.677	7.874	0.0-0.197	1.260	2.205	—	2.750					
1960 00516090	CAT50-HDZ16	-90	1	0.138-0.630	3.543	1.496-3.189	1.378	0.0-0.236	1.417	2.441	—	2.750	3.6				
1960 00516105		-105	1	0.138-0.630	4.134	1.496-3.189	1.969	0.0-0.236	1.417	2.441	—	2.750	3.7				
1960 00516120		-120	1	0.138-0.630	4.724	1.496-3.189	2.559	0.0-0.236	1.417	2.441	—	2.750	3.7				
1960 00516135		-135	1	0.138-0.630	5.315	1.496-3.189	3.150	0.0-0.236	1.417	2.441	—	2.750	3.8				
1960 00516165		-165	1	0.138-0.630	6.496	1.496-3.189	4.331	0.0-0.236	1.417	2.441	—	2.750	4				
1960 00516195		-195	1	0.138-0.630	7.677	1.496-3.189	5.512	0.0-0.236	1.417	2.441	—	2.750					
1960 00516225		-225	1	0.138-0.630	8.858	1.496-3.189	6.693	0.0-0.236	1.417	2.441	—	2.750					
1960 00516255		-255	1	0.138-0.630	10.039	1.496-3.189	7.874	0.0-0.236	1.417	2.441	—	2.750					
1960 10522105	CAT50-HDZ22-A	-105	3	0.138-0.866	4.134	1.850-4.055	2.205	0.0-0.315	1.811	2.992	1.378	2.750	4.1				
1960 10522120		-120	3	0.138-0.866	4.724	1.850-4.055	2.795	0.0-0.315	1.811	2.992	1.378	2.750	4.3				
1960 10522135		-135	3	0.138-0.866	5.315	1.850-4.055	3.386	0.0-0.315	1.811	2.992	1.378	2.750	4.4				
1960 10522165		-165	3	0.138-0.866	6.496	1.850-4.055	3.976	0.0-0.315	1.811	2.992	1.378	2.750	4.7				
1960 10522195		-195	3	0.138-0.866	7.677	1.850-4.055	5.157	0.0-0.315	1.811	2.992	1.378	2.750					
1960 10522225		-225	3	0.138-0.866	8.858	1.850-4.055	6.339	0.0-0.315	1.811	2.992	1.378	2.750	5.3				
1960 10522255		-255	3	0.138-0.866	10.039	1.850-4.055	7.520	0.0-0.315	1.811	2.992	1.378	2.750					

1. La boquilla, llave inglesa, tornillo Allen opresor de preajuste y el tornillo de preajuste para procesos semisecos se venden por separado. El tornillo estándar de preajuste está incluido.
2. Consulte la pág. 096 para conocer la longitud mínima para insertar herramientas en caso de usar nuestras boquillas refrigerantes (OH, C o MS).
3. L1 indica la dimensión al usarlo con un tornillo de preajuste.
4. Consulte la pág. 521 para conocer el Torque recomendado para nuestros productos.
5. Incluye el tornillo estándar de preajuste.

1. Collet, spanner, hexagon head preset screw, preset screw for semi-dry processing, and hex. wrench are sold separately. Standard preset screw is included.
2. Refer to P.096 for minimum tool insertion length in case of using our coolant collets (OH,C or MS).
3. L1 indicates dimension when using with a preset screw.
4. See P.521 for standard Tightening Torque.
5. Standard preset screw is included.

Boquilla Collet	Llave Inglesa Spanner	Tornillo de preajuste Preset screw	Llave Allen Hex. Wrench
Pág. 090-093	Pág. 099	Pág. 098	Pág. 099
			

Ejemplo para Ordenar - Ordering Example

CAT40 - HDZ 12 - 150

Interfaz y diámetro de husillo

Shank size

Máx. Diámetro Interno de boquilla

Max. collet I.D.

Longitud de proyección

Projection length (L)

"R" Zero Holder for Large Diameter

- La excentricidad del borde de corte se puede ajustar hasta casi cero. Es adecuado para rima con diámetro amplio.
- Runout of the cutting edge can be adjusted as close as to zero. Suitable for large diameter reaming.

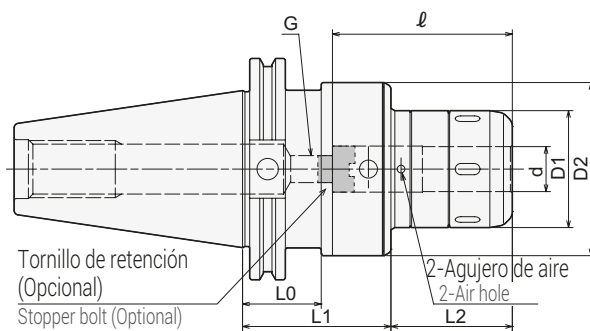

Precaución / Caution

Favor de girar el anillo de sujeción en sentido contrario a las manecillas del reloj por más de 360 grados después de remover una herramienta de corte.

Please rotate the clamping ring counterclockwise more than 360 degrees after a cutting tool is removed.

Medidas Métricas - Metric Sizes

Unidad : Métrico
Unit : Metric

Código Code	Modelo Model	Tipo Type	d	L	L1	L2	D1	D2	L0	ℓ	G P=1.0	Llave Inglesa Spanner	Llave Allen Hex. Wrench
1850 41432135	CAT40 -CTZ1000SA-135	1	25.4	135	64	71	61	74	35	80	12	HS-2.5-25	L-6L (Incluido / Included)
1850 41432150	-150	1	25.4	150	64	86	61	74	35	80	12		
1850 41440135	-CTZ1250SA-135	1	31.75	135	64	71	68	80	35	120	18	HS-3-32	
1850 41440150	-150	1	31.75	150	64	86	68	80	35	120	18		
1850 41532135	CAT50 -CTZ1000SA-135	1	25.4	135	64	71	61	74	35	80	12	HS-2.5-25	
1850 41532150	-150	1	25.4	150	64	86	61	74	35	80	12		
1850 41540135	-CTZ1250SA-135	1	31.75	135	64	71	68	80	35	120	18	HS-3-32	
1850 41540150	-150	1	31.75	150	64	86	68	80	35	120	18		

- Al hacer su orden, indique el número de llaves inglesas que requiere. Las llaves inglesas "son gratuitas" y están limitadas al número de portaherramientas de fresado de su orden.
 - La llave Allen está incluida L-6L.
 - Todos los accesorios, incluyendo las boquillas rectas, se pueden usar con los portaherramientas previamente mencionados.
 - Use dos piezas de tornillos Allen (incluidos) M4 x 5 (S) para cerrar los orificios vacíos en el portaherramienta cuando se use refrigerante interno.
- When ordering, indicate number of spanners required. "No charge" spanners are limited to number of holders on order.
 - A L-6L wrench is included.
 - All accessories including straight collets can be used with above holders.
 - Use 2pcs. of M4 x 5(S) hex. screw to close air holes on the holder when internal coolant is used.

Tornillo de retención Stopper Bolt	Boquilla recta Straight Collet	Adaptador Morse Morse Taper Adapter	Adaptador Jacobs Jacobs Adapter
BL (Pág.072)	MC (Pág.070) MCA (Pág.071)	MA (Pág.072) MAB (Pág.072)	JA (Pág.073) JAB (Pág.073)

Ejemplo para Ordenar - Ordering Example

CAT40 - CTZ 1000 A - 135

Interfaz y diámetro de husillo

Diámetro Interior

Longitud de proyección

Shank size

I.D. (d)

Projection length (L)

Llave Inglesa
Spanner
Pág. 073



Longitud mín de inserción Min. chucking length

Sujeción directa (sin boquilla MC)
Direct Chucking (without MC Collet)

Modelo Model	Longitud mín de inserción Min. chucking length
CTZ1000A, CTZ1250A	50mm

Con boquilla MC
With MC collet

D.I. de la boquilla Collet I.D.	Longitud mín de inserción Min. chucking length	
	MC	MC-C, MC-OH
1/4, 5/16	30mm	30mm
3/8, 1/2	40mm	40mm
5/8, 3/4, 7/8	45mm	45mm
1	50mm	50mm

PHZ · S

Slim Hydro "R" Zero Holder

Tipo1
Type1

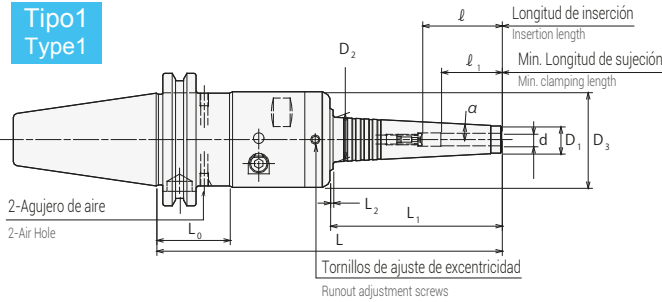

Tipo2
Type2

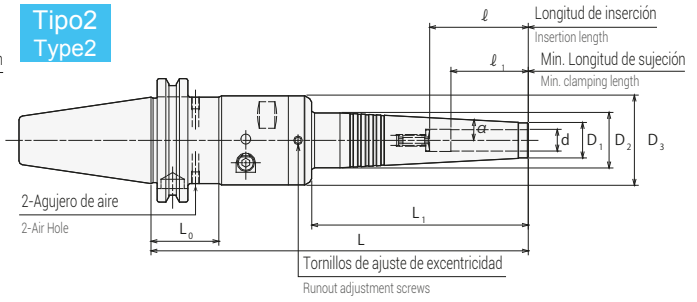

Medidas Métricas - Metric Sizes

Unidad : Métrico
Unit : Metric

Código Code	Modelo Model	Tipo Type	d	L	L1	L2	D1	D2	D3	L0	ℓ	ℓ1	α	Llave Allen para el tornillo de accionamiento (Opcional) Hex. wrench for the actuating screw (Optional)	Llave Allen para Tornillos de ajuste de excentricidad (Opcional) Hex. wrench for runout adjustment screw (Optional)
1810 00406150	CAT40 -PHZ06S -150	1	6	150	67	1.5	13	19.9	46	35.05	37	29	3°	L-4T	L-3T
1810 00406180	-180	1	6	180	97	1.5	13	23.1	46	35.05	37	29	3°		
1810 00407150	CAT40 -PHZ07S -150	1	7	150	67	1.5	14	20.9	46	35.05	37	29	3°		
1810 00407180	-180	1	7	180	97	1.5	14	24.1	46	35.05	37	29	3°		
1810 00408150	CAT40 -PHZ08S -150	1	8	150	67	1.5	15	21.9	46	35.05	50	29	3°		
1810 00408180	-180	1	8	180	97	1.5	15	25.1	46	35.05	50	29	3°		
1810 00409150	CAT40 -PHZ09S -150	1	9	150	67	1.5	16	22.9	46	35.05	50	40	3°		
1810 00409180	-180	1	9	180	97	1.5	16	26.1	46	35.05	50	40	3°		
1810 00410150	CAT40 -PHZ10S -150	1	10	150	67	1.5	17	23.9	46	35.05	50	40	3°		
1810 00410180	-180	1	10	180	97	1.5	17	27.1	46	35.05	50	40	3°		
1810 00411150	CAT40 -PHZ11S -150	1	11	150	67	1.5	18	24.9	46	35.05	50	40	3°		
1810 00411180	-180	1	11	180	97	—	18	28	46	35.05	50	40	3°		
1810 00412150	CAT40 -PHZ12S -150	1	12	150	67	1.5	19	25.9	46	35.05	70	40	3°		
1810 00412180	-180	2	12	180	97	—	19	28.2	46	35.05	70	40	3°		

- La tolerancia del diámetro del zanco de la herramienta debe ser de h6 o menor.
 - No deje el portaherramienta con el tornillo de mando ajustado cuando el portaherramienta esté vacío.
 - Los tornillos con cabeza hexagonal (incluidos) son necesarios para taponar los orificios de aire para el abastecimiento de suministro a través del centro.
- Tool shank diameter tolerance must be within h6.
 - Do not leave the holder with actuating screw tightened when the chuck is empty.
 - Hex-head screws (included) are necessary to plug air hole for center through coolant feed.

Torque recomendado (llave Allen : pág. 520) Tightening torque (Torque wrench : P.520)			
Modelo Model	I.D. (d)		Torque de apriete Tightening torque (Nm)
	mm	pulgada - inch	
PHZ·S	06 ~ 12	—	9 ~ 10

Llave Allen
Hex. Wrench
Pág. 099



Ordering Example

CAT40 - PHZ 12 S - 150		
Interfaz y diámetro de husillo	Diámetro Interior	Longitud de proyección
Shank size	I.D. (d)	Projection length (L)

PHC-A



Power Hydro Chuck

- Hydro Chuck con capacidad de uso de boquillas. Adecuado para cortes de alta precisión.
- Hydro chuck with collet holder flexibility. Suitable for high precision cutting.

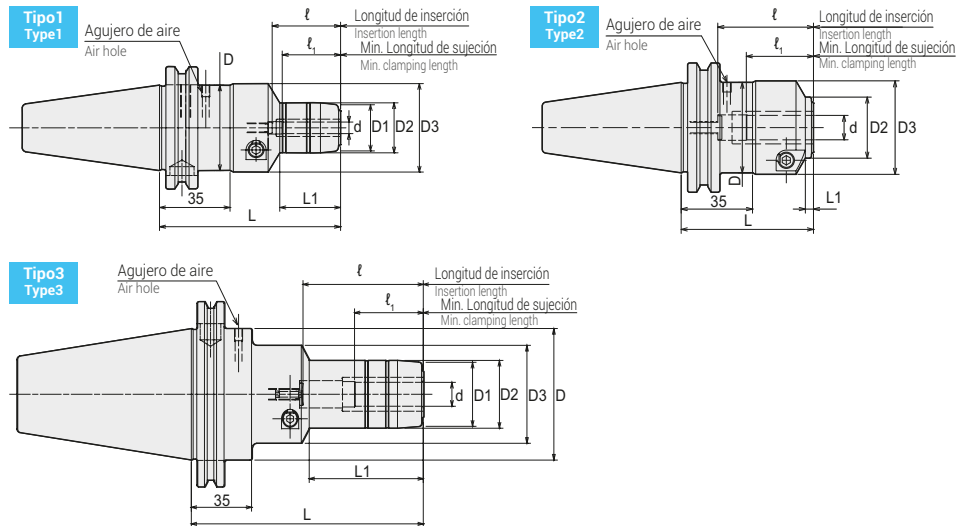

Medida en Pulgadas - Inch Sizes

Unidad : Pulgadas
Unit : Inch

Código Code	Modelo Model	Tipo Type	d	L	L ₁	D	D ₁	D ₂	D ₃	ℓ	ℓ ₁	Llave Allen (Opcional) Hex. Wrench (Optional)	
393200674000	CAT40 -PHC0125A -75	1	0.125	2.953	0.78	1.75	—	0.945	1.791	1.102	0.709	L-4T (4mm)	
1860 11408065	CAT40 -PHC0250A -65	2	0.25	2.56	0.158	1.75	—	1.024	1.807	1.338	1.142		
1860 11408090	-90	1	0.25	3.544	1.19	1.75	0.945	1.024	1.811	1.338	1.142		
1860 11408120	-120	1	0.25	4.725	1.623	1.75	0.945	1.024	1.811	1.771	1.142		
1860 11410065	CAT40 -PHC0312A -65	2	0.312	2.56	0.158	1.75	—	1.103	1.807	1.338	1.142		
1860 11410090	-90	1	0.312	3.544	1.213	1.75	1.024	1.103	1.811	1.338	1.142		
1860 11410120	-120	1	0.312	4.725	1.646	1.75	1.024	1.103	1.811	1.771	1.142		
1860 11412065	CAT40 -PHC0375A -65	2	0.375	2.56	0.158	1.75	—	1.182	1.807	1.771	1.3		
1860 11412105	-105	1	0.375	4.134	1.758	1.75	1.103	1.182	2.048	1.968	1.575		
1860 11412135	-135	1	0.375	5.315	2.546	1.75	1.103	1.182	2.048	2.755	1.575		
1860 11416065	CAT40 -PHC0500A -65*	2	0.5	2.56	0.158	1.75	—	1.182	1.969	1.771	1.3		
1860 11416105	-105*	1	0.5	4.134	1.826	1.75	1.339	1.418	2.048	1.968	1.575		
1860 11416135	-135*	1	0.5	5.315	2.614	1.75	1.339	1.418	2.048	2.755	1.575		
1860 11420065	CAT40 -PHC0625A -65	2	0.625	2.56	0.158	1.75	—	1.182	1.969	1.771	1.3		
1860 11420105	-105	1	0.625	4.134	1.849	1.75	1.418	1.496	2.048	1.968	1.575		
1860 11420135	-135	1	0.625	5.315	2.637	1.75	1.418	1.496	2.048	2.755	1.575		
1860 11424105	CAT40 -PHC0750A -105*	1	0.75	4.134	1.963	1.75	1.575	1.654	1.811	1.968	1.575		
1860 11424135	-135*	1	0.75	5.315	2.75	1.75	1.575	1.654	1.811	2.755	1.575		
1860 11432120	CAT40 -PHC1000A -120	1	1	4.725	2.328	1.75	1.969	2.048	2.441	2.362	1.969		L-6T (6mm)
1860 11432150	-150	1	1	5.906	3.115	1.75	1.969	2.048	2.441	3.149	1.969		
1860 11440135	CAT40 -PHC1250A -135	1	1.25	5.315	—	1.75	2.363	2.441	2.441	2.952	2.56		
1860 11440165	-165	1	1.25	6.496	—	1.75	2.363	2.441	—	3.149	2.56		

Medida en Pulgadas - Inch Sizes

Unidad : Pulgadas
Unit : Inch

Código Code	Modelo Model	Tipo Type	d	L	L ₁	D	D ₁	D ₂	D ₃	ℓ	ℓ ₁	Llave Allen (Opcional) Hex. Wrench (Optional)
393200669000	CAT50 -PHC0250A - 90	3	0.25	3.544	1.19	2.75	0.945	1.024	1.811	1.338	1.142	
393200667000	- 120	3	0.25	4.725	1.623	2.75	0.945	1.024	1.811	1.771	1.142	
393200668000	- 150	3	0.25	5.906	1.623	2.75	0.945	1.024	1.811	1.771	1.142	
393200672000	CAT50 -PHC0312A - 90	3	0.312	3.544	1.213	2.75	1.024	1.103	1.811	1.338	1.142	
393200670000	- 120	3	0.312	4.725	1.646	2.75	1.024	1.103	1.811	1.771	1.142	
393200671000	- 150	3	0.312	5.906	1.646	2.75	1.024	1.103	1.811	1.771	1.142	
393200661000	CAT50 -PHC0375A - 105	3	0.375	4.134	1.758	2.75	1.103	1.182	2.048	1.968	1.575	
393200662000	- 135	3	0.375	5.315	2.546	2.75	1.103	1.182	2.048	2.755	1.575	
393200663000	- 165	3	0.375	6.496	2.546	2.75	1.103	1.182	2.048	2.755	1.575	
—	CAT50 -PHC0500A - 105*	3	0.5	4.134	1.826	2.75	1.339	1.418	2.048	1.968	1.575	
393200673000	- 135*	3	0.5	5.315	2.614	2.75	1.339	1.418	2.048	2.755	1.575	
393200652000	- 165*	3	0.5	6.496	2.614	2.75	1.339	1.418	2.048	2.755	1.575	
393200653000	CAT50 -PHC0625A - 105	3	0.625	4.134	1.849	2.75	1.418	1.496	2.048	1.968	1.575	
393200654000	- 135	3	0.625	5.315	2.637	2.75	1.418	1.496	2.048	2.755	1.575	
393200655000	- 165	3	0.625	6.496	2.637	2.75	1.418	1.496	2.048	2.755	1.575	
186200031000	CAT50 -PHC0750A - 105*	3	0.75	4.134	1.963	2.75	1.575	1.654	1.811	1.968	1.575	
393200656000	- 135*	3	0.75	5.315	2.75	2.75	1.575	1.654	1.811	2.755	1.575	
393200657000	- 165*	3	0.75	6.496	2.75	2.75	1.575	1.654	1.811	2.755	1.575	
393200658000	CAT50 -PHC1000A - 120	3	1	4.725	2.328	2.75	1.969	2.048	2.441	2.362	1.969	L-6T (6mm)
393200659000	- 150	3	1	5.906	3.115	2.75	1.969	2.048	2.441	3.149	1.969	
393200660000	- 165	3	1	6.496	3.115	2.75	1.969	2.048	2.441	3.149	1.969	
393200675000	CAT50 -PHC1250A - 135	3	1.25	5.315	—	2.75	2.363	2.441	—	2.952	2.56	
393200664000	- 165	3	1.25	6.496	—	2.75	2.363	2.441	—	3.149	2.56	

1. Favor de utilizar herramientas de corte con una tolerancia menor a h7. Es recomendada una tolerancia menor que 0/-0.01 para nuevas herramientas de corte.
2. No dejar el portaherramienta con el tornillo de accionamiento apretado cuando el diámetro interno del portaherramienta se encuentre sin herramienta de corte.
3. PHC0500A Y PHC0750A cuentan con orificios de acople para perno, para las boquillas que tienen incluido el perno de retención.
4. El tornillo Allen es necesario para tapan el orificio de aire para habilitar la alimentación de refrigeración por centro de la boquilla.
5. * Es posible utilizar boquillas PHS.

1. Please use a cutting tool with a tolerance of less than h7. A tolerance of less than 0/-0.01 is recommended for new cutting tools.
2. Do not leave the holder with actuating screw tightened when the chuck is empty.
3. PHC0500A and PHC0750A have pin holes for collet with stopper pin on its body.
4. Hex-head screws are necessary to plug air hole for center through coolant feed.
5. * Compatible for PHS collet use.

Ejemplo para Ordenar - Ordering Example

CAT40 - PHC 0250 A - 120Interfaz y diámetro
de husillo

Shank size

Diámetro
Interno

I.D.(d)

Longitud de
proyección

Projection length(L)

Boquilla PHS

PHS Collet

Pág.114

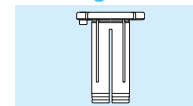

Llave Allen

Hex. wrench

Pág. 099



Torque recomendado (llave Allen : Pág. 520)

Tightening torque (Torque wrench : P. 520)

Modelo Model	I.D. (d)		Torque de ajuste Tightening torque (Nm)
	Pulgada-inch	Métrico-metric	
PHC-A	0250 ~ 0312	06~08	11 ~ 12
PHC-A	0375 ~ 0750	09~20	7 ~ 8
PHC-A	1000, 1250	25, 32	29 ~ 30

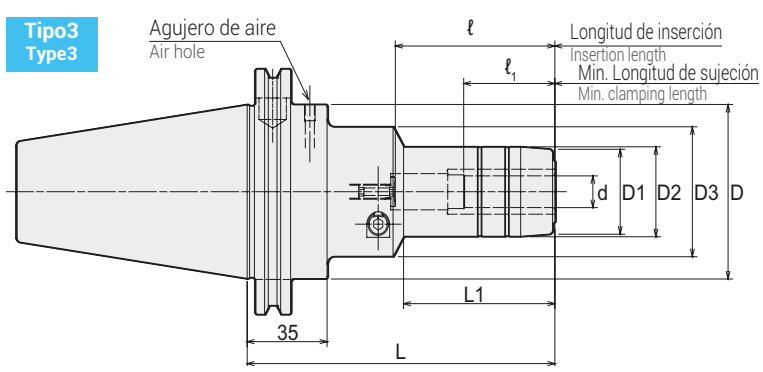
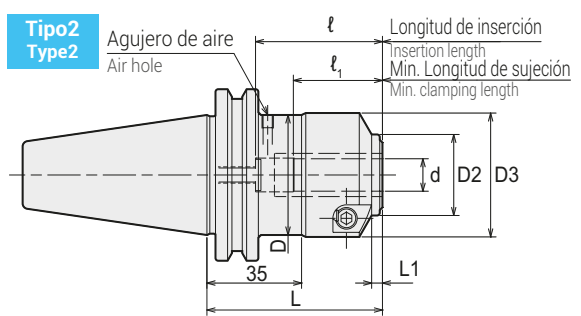
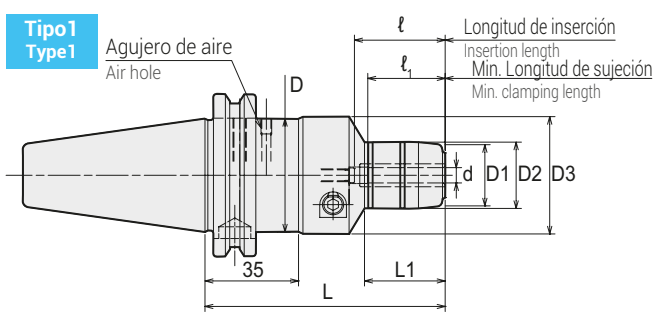

Medidas Métricas - Metric Sizes Unidad : Métrico
Unit : Metric

Código Code	Modelo Model	Tipo Type	d	L	L ₁	D	D ₁	D ₂	D ₃	ℓ	ℓ ₁	Llave Allen (Opcional) Hex. Wrench (Optional)
1860 01403075	CAT40 -PHC03A - 75	1	3	75	19.8	—	24	46	—	—	18	L-4T (4mm)
1860 01404080	CAT40 -PHC04A - 80	1	4	80	25.1	—	25	46	—	29	24	
1860 01406065	CAT40 -PHC06A - 65	2	6	65	4	—	—	26	44.45	34	29	
1860 01406090	- 90	1	6	90	30	44.45	24	26	46	34	29	
1860 01406120	- 120	1	6	120	41	44.45	24	26	46	45	29	
1860 01407065	CAT40 -PHC07A - 65	2	7	65	4	—	—	28	44.45	34	29	
1860 01407090	- 90	1	7	90	30	44.45	26	28	46	34	29	
1860 01407120	- 120	1	7	120	41	44.45	26	28	46	45	29	
1860 01408065	CAT40 -PHC08A - 65	2	8	65	4	—	—	28	44.45	34	29	
1860 01408090	- 90	1	8	90	30	44.45	26	28	46	34	29	
1860 01408120	- 120	1	8	120	41	44.45	26	28	46	45	29	
1860 01409065	CAT40 -PHC09A - 65	2	9	65	4	—	—	30	44.45	45	33	
1860 01409105	- 105	1	9	105	44	44.45	28	30	52	50	40	
1860 01409135	- 135	1	9	135	64	44.45	28	30	52	70	40	
1860 01410065	CAT40 -PHC10A - 65	2	10	65	4	—	—	30	44.45	45	33	
1860 01410105	- 105	1	10	105	44	44.45	28	30	52	50	40	
1860 01410135	- 135	1	10	135	64	44.45	28	30	52	70	40	
1860 01411065	CAT40 -PHC11A - 65	2	11	65	4	—	—	30	44.45	45	33	
1860 01411105	- 105	1	11	105	45	44.45	30	32	52	50	40	
1860 01411135	- 135	1	11	135	65	44.45	30	32	52	70	40	
1860 01412065	CAT40 -PHC12A - 65 *	2	12	65	4	—	—	30	44.45	45	33	
1860 01412105	- 105 *	1	12	105	45	44.45	30	32	52	50	40	
1860 01412135	- 135 *	1	12	135	65	44.45	30	32	52	70	40	
1860 01413065	CAT40 -PHC13A - 65	3	13	65	4	44.45	—	30	50	45	33	
1860 01413105	- 105	1	13	105	46	44.45	34	36	52	50	40	
1860 01413135	- 135	1	13	135	66	44.45	34	36	52	70	40	
1860 01414065	CAT40 -PHC14A - 65	3	14	65	4	44.45	—	30	50	45	33	
1860 01414105	- 105	1	14	105	46	44.45	34	36	52	50	40	
1860 01414135	- 135	1	14	135	66	44.45	34	36	52	70	40	
1860 01415065	CAT40 -PHC15A - 65	3	15	65	4	44.45	—	30	50	45	33	
1860 01415105	- 105	1	15	105	46	44.45	36	38	52	50	40	
1860 01415135	- 135	1	15	135	66	44.45	36	38	52	70	40	
1860 01416065	CAT40 -PHC16A - 65	3	16	65	4	44.45	—	30	50	45	33	
1860 01416105	- 105	1	16	105	46	44.45	36	38	52	50	40	
1860 01416135	- 135	1	16	135	66	44.45	36	38	52	70	40	
1860 01420105	CAT40 -PHC20A - 105 *	1	20	105	49	44.45	40	42	46	50	40	
1860 01420135	- 135 *	1	20	135	69	44.45	40	42	46	70	40	
1860 01425120	CAT40 -PHC25A - 120	1	25	120	59	44.45	50	52	62	60	50	
1860 01425150	- 150	1	25	150	79	44.45	50	52	62	80	50	
1860 01432135	CAT40 -PHC32A - 135	1	32	135	100	44.45	60	62	—	75	65	
1860 01432165	- 165	1	32	165	130	44.45	60	62	—	80	65	

Medidas Métricas - Metric Sizes

Unidad : Métrico
Unit : Metric

Código Code	Modelo Model	Tipo Type	d	L	L ₁	D	D ₁	D ₂	D ₃	ℓ	ℓ1	Llave Allen (Opcional) Hex. Wrench (Optional)
393200719000	CAT50 -PHC06A - 90	3	6	90	30	69.85	24	26	46	34	29	L-4T (4mm)
393200587000	- 120	3	6	120	41	69.85	24	26	46	45	29	
393200718000	- 150	3	6	150	41	69.85	24	26	46	45	29	
393200722000	CAT50 -PHC07A - 90	3	7	90	30	69.85	26	28	46	34	29	
393200720000	- 120	3	7	120	41	69.85	26	28	46	45	29	
393200721000	- 150	3	7	150	41	69.85	26	28	46	45	29	
393200650000	CAT50 -PHC08A - 90	3	8	90	30	69.85	26	28	46	34	29	
393200723000	- 120	3	8	120	41	69.85	26	28	46	45	29	
393200724000	- 150	3	8	150	41	69.85	26	28	46	45	29	
393200725000	CAT50 -PHC09A - 105	3	9	105	44	69.85	28	30	52	50	40	
303200726000	- 135	3	9	135	64	69.85	28	30	52	70	40	
393200727000	- 165	3	9	165	64	69.85	28	30	52	70	40	
393200728000	CAT50 -PHC10A - 105	3	10	105	44	69.85	28	30	52	50	40	
393200588000	- 135	3	10	135	64	69.85	28	30	52	70	40	
393200729000	- 165	3	10	165	64	69.85	28	30	52	70	40	
393200730000	CAT50 -PHC11A - 105	3	11	105	45	69.85	30	32	52	50	40	
393200731000	- 135	3	11	135	65	69.85	30	32	52	70	40	
393200732000	- 165	3	11	165	65	69.85	30	32	52	70	40	
393200733000	CAT50 -PHC12A - 105*	3	12	105	45	69.85	30	32	52	50	40	
393200589000	- 135*	3	12	135	65	69.85	30	32	52	70	40	
393200734000	- 165*	3	12	165	65	69.85	30	32	52	70	40	
393200735000	CAT50 -PHC13A - 105	3	13	105	46	69.85	34	36	52	50	40	
393200736000	- 135	3	13	135	66	69.85	34	36	52	70	40	
393200737000	- 165	3	13	165	66	69.85	34	36	52	70	40	
393200738000	CAT50 -PHC14A - 105	3	14	105	46	69.85	34	36	52	50	40	
393200739000	- 135	3	14	135	66	69.85	34	36	52	70	40	
393200740000	- 165	3	14	165	66	69.85	34	36	52	70	40	
393200741000	CAT50 -PHC15A - 105	3	15	105	46	69.85	36	38	52	50	40	
393200742000	- 135	3	15	135	66	69.85	36	38	52	70	40	
393200743000	- 165	3	15	165	66	69.85	36	38	52	70	40	
—	CAT50 -PHC16A - 105	3	16	105	46	69.85	36	38	52	50	40	
—	- 135	3	16	135	66	69.85	36	38	52	70	40	
—	- 165	3	16	165	66	69.85	36	38	52	70	40	
186200022000	CAT50 -PHC20A - 105*	3	20	105	49	69.85	40	42	46	50	40	
—	- 135*	3	20	135	69	69.85	40	42	46	70	40	
186200027000	- 165*	3	20	165	69	69.85	40	42	46	70	40	
186200023000	CAT50 -PHC25A - 120	3	25	120	59	69.85	50	52	62	64	50	
—	- 150	3	25	150	79	69.85	50	52	62	80	50	
—	- 165	3	25	165	79	69.85	50	52	62	80	50	
—	CAT50 -PHC32A - 135	3	32	135	—	69.85	60	62	—	75	65	
—	- 165	3	32	165	—	69.85	60	62	—	80	65	

1. Utilice la herramienta de corte con una tolerancia menor a h7.

Es recomendada una tolerancia menor que 0/-0.01 para nuevas herramientas de corte.

2. No dejar el portaherramienta con el tornillo de accionamiento apretado, cuando el diámetro interno del portaherramienta se encuentre sin herramienta de corte.

3. PHC12A y PHC20A cuentan con orificios de acople para perno, para las boquillas que tienen incluido el perno de retención.

4. El tornillo Allen es necesario para tapar el orificio de aire para habilitar la alimentación de refrigeración por centro de la boquilla.

5. * Es posible utilizar boquillas PHS.

1. Please use a cutting tool with a tolerance of less than h7. A tolerance of less than 0/-0.01 is recommended for new cutting tools.

2. Do not leave the holder with actuating screw tightened when the chuck is empty.

3. PHC12A and PHC20A have pin holes for collet with stopper pin on its body.

4. Hex-head screws are necessary to plug air hole for center through coolant feed.

5. * Compatible for PHS collet use.

Ejemplo para Ordenar - Ordering Example

CAT40 - PHC 09 A - 120

Interfaz y
diámetro de husillo
Shank size

Diámetro
Interno
I.D.(d)

Longitud de
proyección
Projection length(L)

Boquilla PHS
PHS Collet
Pág.114

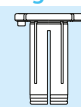

Llave Allen
Hex. wrench
Pág. 099



Torque recomendado (Llave Allen : Pág. 520)
Tightening torque (Torque wrench : P.520)

Modelo - model	I.D. (d)	Torque de ajuste Tightening torque
	mm	(Nm)
PHC-A	06 ~ 08	11 ~ 12
PHC-A	09 ~ 20	7 ~ 8
PHC-A	25, 32	29 ~ 30

Unidad de ajuste de longitud - Length adjustment unit

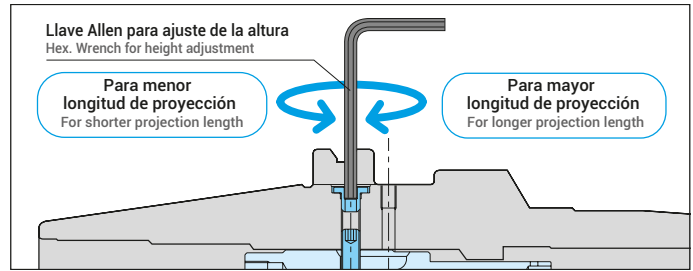
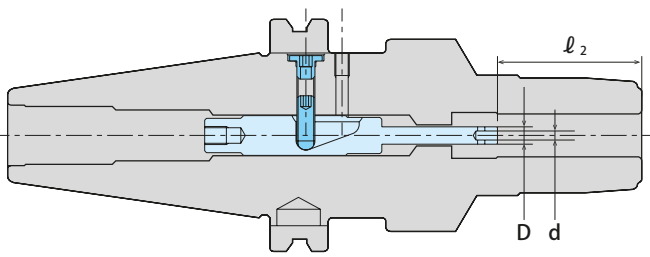

Medida en Pulgadas - Inch Sizes

Unidad : Métrico
Unit : Metric

Código Code	Unidad de ajuste de longitud Length adjustment unit	Portaherramienta correspondiente Matched chuck	Rango de ajuste Adjustment range ℓ_2	Cantidad de ajuste Adjustable amount	Diámetro interno del extremo del pasador Pin end I.D. d	Diámetro externo del extremo del pasador Pin end O.D. D
3934 24045423	PHC-P404-5423	CAT40 -PHC0250A -90	29-34	5	2	3.8
3934 24047334	PHC-P404-7334	-120	29-39	10	2	3.8
3934 24047328	PHC-P404-7328	-120	35-45	10	2	3.8
3934 24045423	PHC-P404-5423	CAT40 -PHC0312A -90	29-34	5	2	3.8
3934 24047334	PHC-P404-7334	-120	29-39	10	2	3.8
3934 24047328	PHC-P404-7328	-120	35-45	10	2	3.8
3934 24054932	PHC-P405-4932	CAT40 -PHC0375A -105	40-50	10	2.5	4.8
3934 24055952	PHC-P405-5952	-135	40-50	10	2.5	4.8
3934 24054952	PHC-P405-4952	-135	50-60	10	2.5	4.8
3934 24054942	PHC-P405-4942	-135	60-70	10	2.5	4.8
3934 24054932	PHC-P405-4932	CAT40 -PHC0500A -105	40-50	10	2.5	4.8
3934 24055952	PHC-P405-5952	-135	40-50	10	2.5	4.8
3934 24054952	PHC-P405-4952	-135	50-60	10	2.5	4.8
3934 24054942	PHC-P405-4942	-135	60-70	10	2.5	4.8
3934 24054932	PHC-P405-4932	CAT40 -PHC0625A -105	40-50	10	2.5	4.8
3934 24055952	PHC-P405-5952	-135	40-50	10	2.5	4.8
3934 24054952	PHC-P405-4952	-135	50-60	10	2.5	4.8
3934 24054942	PHC-P405-4942	-135	60-70	10	2.5	4.8
3934 24054932	PHC-P405-4932	CAT40 -PHC0750A -105	40-50	10	2.5	4.8
3934 24055952	PHC-P405-5952	-135	40-50	10	2.5	4.8
3934 24054952	PHC-P405-4952	-135	50-60	10	2.5	4.8
3934 24054942	PHC-P405-4942	-135	60-70	10	2.5	4.8
3934 24055432	PHC-P405-5432	CAT40 -PHC1000A -120	50-60	10	2.5	4.8
3934 24056452	PHC-P405-6452	-150	50-60	10	2.5	4.8
3934 24055452	PHC-P405-5452	-150	60-70	10	2.5	4.8
3934 24055442	PHC-P405-5442	-150	70-80	10	2.5	4.8
3934 24055432	PHC-P405-5432	CAT40 -PHC1250A -135	65-75	10	2.5	4.8
3934 24056452	PHC-P405-6452	-165	65-75	10	2.5	4.8
3934 24055952	PHC-P405-5952	-165	70-80	10	2.5	4.8

La unidad de ajuste de longitud puede ser utilizada por otros portaherramientas excepto los que tengan 45mm de longitud de proyección. La unidad de ajuste de longitud puede ser utilizada únicamente en portaherramientas con interfaz de husillo BT, CAT y SK.

Length adjustment unit can be used for chucks other than 45mm projection length. Length adjustment unit can be used with BT, CAT and SK shank chucks only.

Ejemplo para Ordenar - Ordering Example

CAT40-PHC10A-105 con un rango de ajuste de entre 40 - 50 mm. (Cantidad ajustable - 10mm).
CAT40-PHC10A-105 with adjustment range of 40-50mm (Adjustable amount-10mm).

Portaherramienta Chuck

CAT40-PHC10A-105

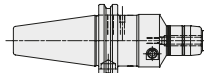

Unidad de ajuste de longitud
Length adjustment unit

PHC-P405-4932



Herramienta de instalación/desinstalación para unidad de ajuste de longitud
Install / removal tool for length adjustment unit

STS-R2



Interfaz y diámetro de husillo.
Shank size.

CAT40

Medida de Llave Allen para ajuste de altura.
Hex. Wrench size for height adjustment.

2.5mm

Herramienta de instalación/desinstalación para unidad de ajuste de longitud.
Install / removal tool for length adjustment unit.

STS-R2

Medidas Métricas - Metric Sizes

Unidad : Métrico
Unit : Metric

Código Code	Unidad de ajuste de longitud Length adjustment unit	Portaherramienta correspondiente Matched chuck	Rango de ajuste Adjustment range €2	Cantidad ajustable Adjustable amount	Diámetro interno del extremo del pasador Pin end I.D. d	Diámetro externo del extremo del pasador Pin end O.D. D
3934 24045423	PHC-P404-5423	CAT40 -PHC06A - 90	29-34	5	2	3.8
3934 24047334	PHC-P404-7334	- 120	29-39	10	2	3.8
3934 24047328	PHC-P404-7328	- 120	35-45	10	2	3.8
3934 24045423	PHC-P404-5423	CAT40 -PHC07A - 90	29-34	5	2	3.8
3934 24047334	PHC-P404-7334	- 120	29-39	10	2	3.8
3934 24047328	PHC-P404-7328	- 120	35-45	10	2	3.8
3934 24045423	PHC-P404-5423	CAT40 -PHC08A - 90	29-34	5	2	3.8
3934 24047334	PHC-P404-7334	- 120	29-39	10	2	3.8
3934 24047328	PHC-P404-7328	- 120	35-45	10	2	3.8
3934 24054932	PHC-P405-4932	CAT40 -PHC09A - 105	40-50	10	2.5	4.8
3934 24055952	PHC-P405-5952	- 135	40-50	10	2.5	4.8
3934 24054952	PHC-P405-4952	- 135	50-60	10	2.5	4.8
3934 24054942	PHC-P405-4942	- 135	60-70	10	2.5	4.8
3934 24054932	PHC-P405-4932	CAT40 -PHC10A - 105	40-50	10	2.5	4.8
3934 24055952	PHC-P405-5952	- 135	40-50	10	2.5	4.8
3934 24054952	PHC-P405-4952	- 135	50-60	10	2.5	4.8
3934 24054942	PHC-P405-4942	- 135	60-70	10	2.5	4.8
3934 24054932	PHC-P405-4932	CAT40 -PHC11A - 105	40-50	10	2.5	4.8
3934 24055952	PHC-P405-5952	- 135	40-50	10	2.5	4.8
3934 24054952	PHC-P405-4952	- 135	50-60	10	2.5	4.8
3934 24054942	PHC-P405-4942	- 135	60-70	10	2.5	4.8
3934 24054932	PHC-P405-4932	CAT40 -PHC12A - 105	40-50	10	2.5	4.8
3934 24055952	PHC-P405-5952	- 135	40-50	10	2.5	4.8
3934 24054952	PHC-P405-4952	- 135	50-60	10	2.5	4.8
3934 24054942	PHC-P405-4942	- 135	60-70	10	2.5	4.8
3934 24054932	PHC-P405-4932	CAT40 -PHC13A - 105	40-50	10	2.5	4.8
3934 24055952	PHC-P405-5952	- 135	40-50	10	2.5	4.8
3934 24054952	PHC-P405-4952	- 135	50-60	10	2.5	4.8
3934 24054942	PHC-P405-4942	- 135	60-70	10	2.5	4.8
3934 24054932	PHC-P405-4932	CAT40 -PHC14A - 105	40-50	10	2.5	4.8
3934 24055952	PHC-P405-5952	- 135	40-50	10	2.5	4.8
3934 24054952	PHC-P405-4952	- 135	50-60	10	2.5	4.8
3934 24054942	PHC-P405-4942	- 135	60-70	10	2.5	4.8
3934 24054932	PHC-P405-4932	CAT40 -PHC15A - 105	40-50	10	2.5	4.8
3934 24055952	PHC-P405-5952	- 135	40-50	10	2.5	4.8
3934 24054952	PHC-P405-4952	- 135	50-60	10	2.5	4.8
3934 24054942	PHC-P405-4942	- 135	60-70	10	2.5	4.8
3934 24054932	PHC-P405-4932	CAT40 -PHC16A - 105	40-50	10	2.5	4.8
3934 24055952	PHC-P405-5952	- 135	40-50	10	2.5	4.8
3934 24054952	PHC-P405-4952	- 135	50-60	10	2.5	4.8
3934 24054942	PHC-P405-4942	- 135	60-70	10	2.5	4.8
3934 24054932	PHC-P405-4932	CAT40 -PHC20A - 105	40-50	10	2.5	4.8
3934 24055952	PHC-P405-5952	- 135	40-50	10	2.5	4.8
3934 24054952	PHC-P405-4952	- 135	50-60	10	2.5	4.8
3934 24054942	PHC-P405-4942	- 135	60-70	10	2.5	4.8
3934 24055432	PHC-P405-5432	CAT40 -PHC25A - 120	50-60	10	2.5	4.8
3934 24056452	PHC-P405-6452	- 150	50-60	10	2.5	4.8
3934 24055452	PHC-P405-5452	- 150	60-70	10	2.5	4.8
3934 24055442	PHC-P405-5442	- 150	70-80	10	2.5	4.8
3934 24055432	PHC-P405-5432	CAT40 -PHC32A - 135	65-75	10	2.5	4.8
3934 24056452	PHC-P405-6452	- 165	65-75	10	2.5	4.8
3934 24055952	PHC-P405-5952	- 165	70-80	10	2.5	4.8

La unidad de ajuste longitudinal puede ser utilizada por otros portaherramientas excepto los que tengan 45mm de longitud de proyección. La unidad de ajuste longitudinal puede ser utilizada únicamente en portaherramientas con interfaz de husillo BT, CAT y SK.

Length adjustment unit can be used for chucks other than 45mm projection length. Length adjustment unit can be used with BT, CAT and SK shank chucks only.

Boquilla PHS
PHS Collet

Pág. 114

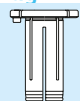
Llave Allen
Hex. Wrench

Pág. 99



PHC-S

Slim Hydro Chuck

- La opción perfecta para trabajos en espacios reducidos, tal como acabados en fresado, barrenado y rimado en máquinas de 5-ejes.
- Perfect choice for tight space applications, such as endmill finishing, drilling and reaming on 5-axis machines.

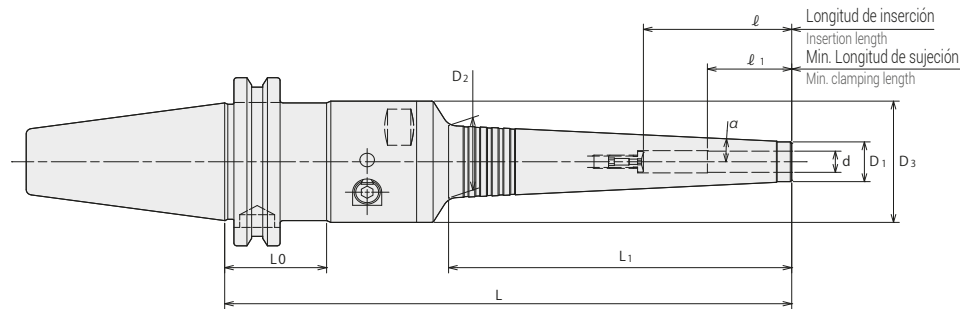

Medida en Pulgadas - Inch Sizes

Unidad : Métrico
Unit : Metric

Código Code	Modelo Model	d	L	L ₁	D ₁	D ₂	D ₃	L ₀	ℓ	ℓ ₁	α	Llave Allen (Opcional) Hex.Wrench (Optional)
370200141000	CAT40 -PHC0125S -100	0.125	3.94	1.18	-	0.433	1.811	1.380	2.047	0.708	3°	L-4T (4mm)
370200142000	-145	0.125	5.71	2.80	-	0.433	1.811	1.380	3.818	0.708	3°	
186200004000	CAT40 -PHC0250S -150	0.250	5.906	2.795	0.512	0.807	1.811	1.380	1.457	1.142	3°	
186200032000	-165	0.250	6.496	3.425	0.512	0.874	1.811	1.380	1.457	1.142	3°	
186200005000	-180	0.250	7.087	4.016	0.512	0.933	1.811	1.380	1.457	1.142	3°	
370200151000	-195	0.250	7.677	4.646	0.512	1.000	1.811	1.380	1.457	1.142	3°	
186200006000	CAT40 -PHC0312S -150	0.312	5.906	2.835	0.591	0.890	1.811	1.380	1.969	1.142	3°	
370200158000	-165	0.312	6.496	3.425	0.591	0.953	1.811	1.380	1.969	1.142	3°	
186200007000	-180	0.312	7.087	4.055	0.591	1.016	1.811	1.380	1.969	1.142	3°	
370200152000	-195	0.312	7.677	4.646	0.591	1.079	1.811	1.380	1.969	1.142	3°	
186200008000	CAT40 -PHC0375S -150	0.375	5.906	2.835	0.669	0.969	1.811	1.380	1.969	1.575	3°	
370200143000	-165	0.375	6.496	3.465	0.669	1.035	1.811	1.380	1.969	1.575	3°	
186200009000	-180	0.375	7.087	4.055	0.669	1.094	1.811	1.380	1.969	1.575	3°	
370200153000	-195	0.375	7.677	4.685	0.669	1.161	1.811	1.380	1.969	1.575	3°	
186200010000	CAT40 -PHC0500S -150	0.500	5.906	2.874	0.787	1.091	1.811	1.380	2.756	1.575	3°	
186200033000	-165	0.500	6.496	3.504	0.787	1.157	1.811	1.380	2.756	1.575	3°	
186200011000	-180	0.500	7.087	4.094	0.787	1.220	1.811	1.380	2.756	1.575	3°	
370200154000	-195	0.500	7.677	4.724	0.787	1.283	1.811	1.380	2.756	1.575	3°	
370200159000	CAT40 -PHC0625S -150	0.625	5.906	2.835	0.906	1.201	2.067	1.380	3.150	1.575	3°	
370200160000	-180	0.625	7.087	4.055	0.906	1.331	2.067	1.380	3.150	1.575	3°	
370200155000	-195	0.625	7.677	4.685	0.906	1.398	2.067	1.380	3.150	1.575	3°	
370200161000	CAT40 -PHC0750S -150	0.750	5.906	2.480	1.102	1.362	2.441	1.380	3.937	1.575	3°	
370200162000	-180	0.750	7.087	3.661	1.102	1.484	2.441	1.380	3.937	1.575	3°	
370200156000	-195	0.750	7.677	4.291	1.102	1.551	2.441	1.380	3.937	1.575	3°	
370200163000	CAT40 -PHC1000S -150	1.000	5.906	2.559	1.457	1.724	2.441	1.380	4.331	1.969	3°	
370200164000	-180	1.000	7.087	3.780	1.457	1.854	2.441	1.380	4.331	1.969	3°	
370200157000	-195	1.000	7.677	4.409	1.457	1.917	2.441	1.380	4.331	1.969	3°	

L-4T
(4mm)

L-6T
(6mm)

Medidas Métricas - Metric Sizes

Unidad : Métrico
Unit : Metric

Código Code	Modelo Model	d	L	L ₁	D ₁	D ₂	D ₃	L0	ℓ	ℓ1	α	Llave Allen (Opcional) Hex.Wrench (Optional)
183000403100	CAT40 -PHC03S -100	3	100	30	11	14	46	—	—	18	3°	L-4T (4mm)
183000403145	-145	3	145	71	11	19	46	—	—	18	3°	
183000404100	CAT40 -PHC04S -100	4	100	30	11	14	46	—	52	24	3°	
183000404145	-145	4	145	71	11	19	46	—	97	24	3°	
183000406150	CAT40 -PHC06S -150	6	150	71	13	20.5	46	35.05	37	29	3°	
183000406165	-165	6	165	87	13	22.2	46	35.05	37	29	3°	
183000406180	-180	6	180	102	13	23.7	46	35.05	37	29	3°	
183000406195	-195	6	195	118	13	25.4	46	35.05	37	29	3°	
183000407150	CAT40 -PHC07S -150	7	150	71	14	21.5	46	35.05	37	29	3°	
183000407165	-165	7	165	87	14	23.2	46	35.05	37	29	3°	
183000407180	-180	7	180	102	14	24.7	46	35.05	37	29	3°	
183000407195	-195	7	195	118	14	26.4	46	35.05	37	29	3°	
183000408150	CAT40 -PHC08S -150	8	150	72	15	22.6	46	35.05	50	29	3°	
183000408165	-165	8	165	87	15	24.2	46	35.05	50	29	3°	
183000408180	-180	8	180	103	15	25.8	46	35.05	50	29	3°	
183000408195	-195	8	195	118	15	27.4	46	35.05	50	29	3°	
183000409150	CAT40 -PHC09S -150	9	150	72	16	23.6	46	35.5	50	40	3°	
183000409165	-165	9	165	87	16	25.2	46	35.5	50	40	3°	
183000409180	-180	9	180	103	16	26.8	46	35.5	50	40	3°	
183000409195	-195	9	195	118	16	28.4	46	35.5	50	40	3°	
183000410150	CAT40 -PHC10S -150	10	150	72	17	24.6	46	35.5	50	40	3°	
183000410165	-165	10	165	88	17	26.3	46	35.5	50	40	3°	
183000410180	-180	10	180	103	17	27.8	46	35.5	50	40	3°	
183000410195	-195	10	195	119	17	29.5	46	35.5	50	40	3°	
183000411150	CAT40 -PHC11S -150	11	150	73	18	25.7	46	35.5	50	40	3°	
183000411165	-165	11	165	88	18	27.3	46	35.5	50	40	3°	
183000411180	-180	11	180	104	18	29.0	46	35.5	50	40	3°	
183000411195	-195	11	195	119	18	30.5	46	35.5	50	40	3°	
183000412150	CAT40 -PHC12S -150	12	150	73	19	26.7	46	35.05	70	40	3°	
183000412165	-165	12	165	88	19	28.3	46	35.05	70	40	3°	
183000412180	-180	12	180	104	19	30.0	46	35.05	70	40	3°	
183000412195	-195	12	195	119	19	31.5	46	35.05	70	40	3°	
183000416150	CAT40 -PHC16S -150	16	150	72	23	30.6	52.5	35.05	75	40	3°	
183000416180	-180	16	180	103	23	33.8	52.5	35.05	80	40	3°	
183000416195	-195	16	195	119	23	35.5	52.5	35.05	80	40	3°	
183000416195	CAT40 -PHC20S -150	20	150	63	28	34.7	62	35.05	70	40	3°	
183000420180	-180	20	180	93	28	37.8	62	35.05	100	40	3°	
183000420195	-195	20	195	109	28	39.5	62	35.05	100	40	3°	
183000425150	CAT40 -PHC25S -150	25	150	65	37	43.9	62	35.05	70	50	3°	
183000425180	-180	25	180	96	37	47.1	62	35.05	100	50	3°	
183000425195	-195	25	195	112	37	48.8	62	35.05	110	50	3°	

1. La tolerancia del diámetro de zanco de la herramienta debe estar dentro de h6.
2. No dejar el portaherramienta con el tornillo de sujeción apretado, cuando el diámetro interno del portaherramienta se encuentre sin herramienta de corte.
3. El tornillo Allen es necesario para tapar el orificio de aire para la función de alimentación de refrigerante por centro de la boquilla.

1. Tool shank diameter tolerance must be within h6.
2. Do not leave the holder with actuating screw tightened when the chuck is empty.
3. Hex-head screws are necessary to plug air hole for center through coolant feed.

Ejemplo para Ordenar - Ordering Example

CAT40 - PHC 12 S- 150Interfaz y
diámetro de husillo
Shank sizeDiámetro
Interno
I.D.(d)Longitud de
proyección
Projection length(L)Llave Allen
Hex. Wrench

Pág. 99



PHC-H

Hydro Chuck Ω

- Hydro Chuck de alta rigidez es la mejor opción para maquinados pesados (de alto impacto).
- High Rigidity Hydro Chuck is the best holder for high efficiency rough machining.

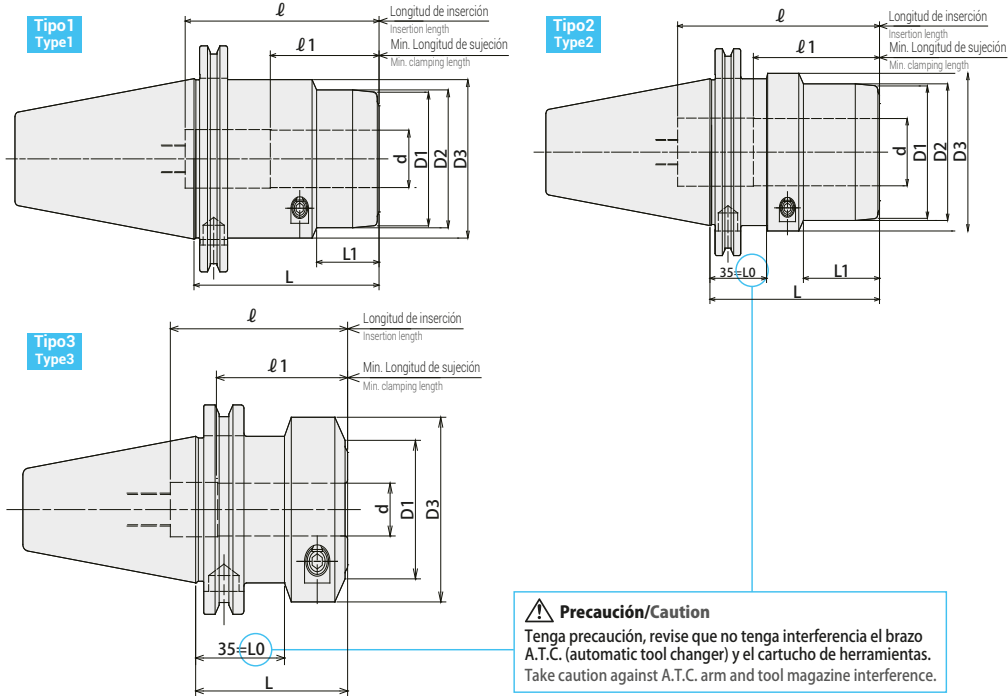

Precaución/ Caution
 Tenga precaución, revise que no tenga interferencia el brazo A.T.C. (automatic tool changer) y el cartucho de herramientas.
 Take caution against A.T.C. arm and tool magazine interference.

Código Code	Modelo Model	Tipo Type	d	L	L1	D1	D2	D3	L0	ℓ	ℓ1	Max. min ⁻¹	kg	Llave Allen (Opcional) Hex. Wrench (Optional)
182001416060	CAT40 -PHC16H - 60	3	16	60	—	42	—	56	35	70	45	20,000	1.2	L-4T
182001416085	- 85	2	16	85	27	42	44	56	35	85	45	20,000	1.5	
182001420085	-PHC20H - 85	2	20	85	26	48	50	60	35	80	50	20,000	1.6	
182001420105	- 105	2	20	105	32	48	50	60	35	110	50	20,000	2.1	L-5T
182001425085	-PHC25H - 85	2	25	85	25	58	60	69	35	80	55	16,000	1.8	
182001425105	- 105	2	25	105	35	58	60	69	35	110	55	16,000	2.4	
182001432120	-PHC32H - 120	2	32	120	47	63	65	75	35	105	65	12,000	2.4	L-5T
182001432135	- 135	2	32	135	47	63	65	75	35	120	65	12,000	3.2	
182001516085	CAT50 -PHC16H - 85	1	16	85	27	42	44	56	—	75	45	15,000	4.0	
182001516105	- 105	1	16	105	27	42	44	56	—	95	45	15,000	4.4	L-4T
182001520085	-PHC20H - 85	1	20	85	32	48	50	60	—	90	50	15,000	4.1	
182001520105	- 105	1	20	105	32	48	50	60	—	110	50	15,000	4.5	
182001525085	-PHC25H - 85	1	25	85	35	58	60	69	—	90	55	15,000	4.2	L-5T
182001525105	- 105	1	25	105	35	58	60	69	—	110	55	15,000	4.8	
182001525135	- 135	1	25	135	35	58	60	69	—	110	55	15,000	5.5	
182001532085	-PHC32H - 85	2	32	85	32	63	65	75	35	90	65	12,000	4.1	L-5T
182001532105	- 105	2	32	105	47	63	65	75	35	120	65	12,000	4.6	
182001532135	- 135	2	32	135	47	63	65	75	35	120	65	12,000	5.6	
182001542085	-PHC42H - 85	2	42	85	—	74	—	89	35	100	73	10,000	4.1	L-6T
182001542105	- 105	2	42	105	46	78	80	89	35	120	73	10,000	5.0	
182001542135	- 135	2	42	135	52	78	80	89	35	120	73	10,000	6.2	

Ejemplo para Ordenar - Ordering Example

CAT40 - PHC 16 H - 60

Interfaz y diámetro de husillo
Shank size

Diámetro Interior
I.D. (d)

Longitud de Proyección
Projection length (L)

Boquilla PHS+H
PHS+H Collet
Pág. 123

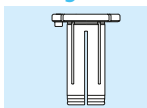

Tornillo de retención
Stopper Bolt
Pág. 123



Shrink Fit (DIN Standard)

- El método de contracción sujeta firmemente a una herramienta de corte al calentar y enfriar el portaherramienta. Alta precisión y mucha fuerza de fresado. (Para DIN)
- Shrinkage method clamps a cutting tool firmly by heating and cooling the chuck. High precision and strong chucking force. (DIN Type)

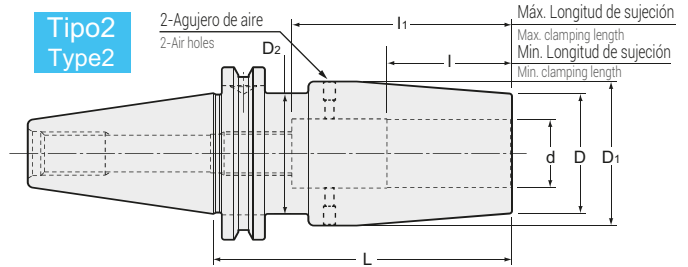
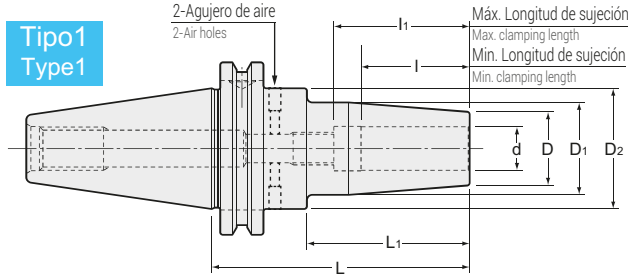

Medida en Pulgadas - Inch Sizes

Unidad : Pulgadas
Unit : Inch

Código Code	Modelo Model	Tipo Type	d	L	L1	D	D1	D2	I	I1	kg
1940 43408095	CAT40 -SRD0250A -95	1	0.250	3.740	2.360	0.827	1.063	1.750	1.024	1.417	
1940 43408120	-120	1	0.250	4.724	3.344	0.827	1.063	1.750	1.024	1.417	1.3
1940 43408160	-160	1	0.250	6.299	4.919	0.827	1.063	1.750	1.024	1.417	
1940 43410095	CAT40 -SRD0312A -95	1	0.312	3.740	2.360	0.827	1.063	1.750	1.024	1.969	
1940 43410120	-120	1	0.312	4.724	3.344	0.827	1.063	1.750	1.024	1.969	
1940 43410160	-160	1	0.312	6.299	4.919	0.827	1.063	1.750	1.024	1.969	
1940 43412095	CAT40 -SRD0375A -95	1	0.375	3.740	2.360	0.945	1.260	1.750	1.260	1.969	1.3
1940 43412120	-120	1	0.375	4.724	3.344	0.945	1.260	1.750	1.260	1.969	
1940 43412160	-160	1	0.375	6.299	4.919	0.945	1.260	1.750	1.260	1.969	
1940 43416095	CAT40 -SRD0500A -95	1	0.500	3.740	2.360	0.945	1.260	1.750	1.457	2.244	1.2
1940 43416120	-120	1	0.500	4.724	3.344	0.945	1.260	1.750	1.457	2.244	
1940 43416160	-160	1	0.500	6.299	4.919	0.945	1.260	1.750	1.457	2.244	1.6
1940 43420095	CAT40 -SRD0625A -95	1	0.625	3.740	2.360	1.063	1.339	1.750	1.575	3.150	
1940 43420120	-120	1	0.625	4.724	3.344	1.063	1.339	1.750	1.575	3.150	
1940 43420160	-160	1	0.625	6.299	4.919	1.063	1.339	1.750	1.575	3.150	
1940 43424095	CAT40 -SRD0750A -95	1	0.750	3.740	2.360	1.299	1.654	1.750	1.575	3.937	
1940 43424120	-120	1	0.750	4.724	3.344	1.299	1.654	1.750	1.575	3.937	
1940 43424160	-160	1	0.750	6.299	4.919	1.299	1.654	1.750	1.575	3.937	
1940 43428095	CAT40 -SRD0875A -95	1	0.875	3.740	2.360	1.299	1.654	1.750	1.654	3.937	
1940 43428120	-120	1	0.875	4.724	3.344	1.299	1.654	1.750	1.654	3.937	
1940 43428160	-160	1	0.875	6.299	4.919	1.299	1.654	1.750	1.654	3.937	
1940 43432110	CAT40 -SRD1000A -110	2	1.000	4.331	—	1.732	2.087	1.750	1.890	3.780	1.8
1940 43432135	-135	2	1.000	5.315	—	1.732	2.087	1.750	1.890	3.937	
1940 43432160	-160	2	1.000	6.299	—	1.732	2.087	1.750	1.890	3.937	
1940 43440110	CAT40 -SRD1250A -110	2	1.250	4.331	—	1.732	2.087	1.750	1.890	3.780	
1940 43440135	-135	2	1.250	5.315	—	1.732	2.087	1.750	1.890	3.937	
1940 43440160	-160	2	1.250	6.299	—	1.732	2.087	1.750	1.890	3.937	
1940 43508095	CAT50 -SRD0250A -95	1	0.250	3.740	2.360	0.827	1.063	2.750	1.024	1.417	
1940 43508120	-120	1	0.250	4.724	3.344	0.827	1.063	2.750	1.024	1.417	
1940 43508160	-160	1	0.250	6.299	4.919	0.827	1.063	2.750	1.024	1.417	
1940 43510095	CAT50 -SRD0312A -95	1	0.312	3.740	2.360	0.827	1.063	2.750	1.024	1.969	
1940 43510120	-120	1	0.312	4.724	3.344	0.827	1.063	2.750	1.024	1.969	3.2
1940 43510160	-160	1	0.312	6.299	4.919	0.827	1.063	2.750	1.024	1.969	3.4
1940 43512095	CAT50 -SRD0375A -95	1	0.375	3.740	2.360	0.945	1.260	2.750	1.260	1.969	
1940 43512120	-120	1	0.375	4.724	3.344	0.945	1.260	2.750	1.260	1.969	3.4
1940 43512160	-160	1	0.375	6.299	4.919	0.945	1.260	2.750	1.260	1.969	3.6
1940 43516095	CAT50 -SRD0500A -95	1	0.500	3.740	2.360	0.945	1.260	2.750	1.457	2.244	
1940 43516120	-120	1	0.500	4.724	3.344	0.945	1.260	2.750	1.457	2.244	3.3
1940 43516160	-160	1	0.500	6.299	4.919	0.945	1.260	2.750	1.457	2.244	3.5
1940 43520095	CAT50 -SRD0625A -95	1	0.625	3.740	2.360	1.063	1.339	2.750	1.575	3.150	
1940 43520120	-120	1	0.625	4.724	3.344	1.063	1.339	2.750	1.575	3.150	
1940 43520160	-160	1	0.625	6.299	4.919	1.063	1.339	2.750	1.575	3.150	3.6
1940 43524095	CAT50 -SRD0750A -95	1	0.750	3.740	2.360	1.299	1.654	2.750	1.575	3.937	
1940 43524120	-120	1	0.750	4.724	3.344	1.299	1.654	2.750	1.575	3.937	3.6
1940 43524160	-160	1	0.750	6.299	4.919	1.299	1.654	2.750	1.575	3.937	3.9
1940 43528095	CAT50 -SRD0875A -95	1	0.875	3.740	2.360	1.299	1.654	2.750	1.654	3.937	
1940 43528120	-120	1	0.875	4.724	3.344	1.299	1.654	2.750	1.654	3.937	
1940 43528160	-160	1	0.875	6.299	4.919	1.299	1.654	2.750	1.654	3.937	3.8
1940 43532105	CAT50 -SRD1000A -105	1	1.000	4.134	2.754	1.732	2.087	2.750	1.890	3.780	3.7
1940 43532120	-120	1	1.000	4.724	3.344	1.732	2.087	2.750	1.890	3.937	3.9
1940 43532160	-160	1	1.000	6.299	4.919	1.732	2.087	2.750	1.890	3.937	4.5
1940 43540105	CAT50 -SRD1250A -105	1	1.250	4.134	2.754	1.732	2.087	2.750	1.890	3.937	
1940 43540120	-120	1	1.250	4.724	3.344	1.732	2.087	2.750	1.890	3.937	3.6
1940 43540160	-160	1	1.250	6.299	4.919	1.732	2.087	2.750	1.890	3.937	4.2
1940 43548105	CAT50 -SRD1500A -105	1	1.500	4.134	2.754	1.732	2.087	2.750	1.890	3.937	
1940 43548120	-120	1	1.500	4.724	3.344	1.732	2.087	2.750	1.890	3.937	3.3
1940 43548160	-160	1	1.500	6.299	4.919	1.732	2.087	2.750	1.890	3.937	

Medidas Métricas - Metric Sizes

Unidad : Métrico
Unit : Metric

Código Code	Modelo Model	Tipo Type	d (mm)	L	L1	D	D1	D2	I	I1	kg
1940 41406095	CAT40 -SRD6A -95	1	6	3.740	2.360	0.827	1.063	1.750	1.024	1.417	
1940 41406120	-120	1	6	4.724	3.344	0.827	1.063	1.750	1.024	1.417	1.3
1940 41406160	-160	1	6	6.299	4.919	0.827	1.063	1.750	1.024	1.417	
1940 41408095	CAT40 -SRD8A -95	1	8	3.740	2.360	0.827	1.063	1.750	1.024	1.969	
1940 41408120	-120	1	8	4.724	3.344	0.827	1.063	1.750	1.024	1.969	
1940 41408160	-160	1	8	6.299	4.919	0.827	1.063	1.750	1.024	1.969	
1940 41410095	CAT40 -SRD10A -95	1	10	3.740	2.360	0.945	1.260	1.750	1.260	1.969	
1940 41410120	-120	1	10	4.724	3.344	0.945	1.260	1.750	1.260	1.969	1.4
1940 41410160	-160	1	10	6.299	4.919	0.945	1.260	1.750	1.260	1.969	
1940 41412095	CAT40 -SRD12A -95	1	12	3.740	2.360	0.945	1.260	1.750	1.457	2.756	
1940 41412120	-120	1	12	4.724	3.344	0.945	1.260	1.750	1.457	2.756	
1940 41412160	-160	1	12	6.299	4.919	0.945	1.260	1.750	1.457	2.756	
1940 41414095	CAT40 -SRD14A -95	1	14	3.740	2.360	1.063	1.339	1.750	1.457	2.756	
1940 41414120	-120	1	14	4.724	3.344	1.063	1.339	1.750	1.457	2.756	
1940 41414160	-160	1	14	6.299	4.919	1.063	1.339	1.750	1.457	2.756	
1940 41416095	CAT40 -SRD16A -95	1	16	3.740	2.360	1.063	1.339	1.750	1.575	3.150	
1940 41416120	-120	1	16	4.724	3.344	1.063	1.339	1.750	1.575	3.150	
1940 41416160	-160	1	16	6.299	4.919	1.063	1.339	1.750	1.575	3.150	
1940 41418095	CAT40 -SRD18A -95	1	18	3.740	2.360	1.299	1.654	1.750	1.575	3.150	1.4
1940 41418120	-120	1	18	4.724	3.344	1.299	1.654	1.750	1.575	3.150	
1940 41418160	-160	1	18	6.299	4.919	1.299	1.654	1.750	1.575	3.150	
1940 41420095	CAT40 -SRD20A -95	1	20	3.740	2.360	1.299	1.654	1.750	1.654	3.937	
1940 41420120	-120	1	20	4.724	3.344	1.299	1.654	1.750	1.654	3.937	
1940 41420160	-160	1	20	6.299	4.919	1.299	1.654	1.750	1.654	3.937	
1940 41425110	CAT40 -SRD25A -110	2	25	4.331	—	1.732	2.087	1.750	1.890	3.780	
1940 41425135	-135	2	25	5.315	—	1.732	2.087	1.750	1.890	3.937	
1940 41425160	-160	2	25	6.299	—	1.732	2.087	1.750	1.890	3.937	
1940 41432110	CAT40 -SRD32A -110	2	32	4.331	—	1.732	2.087	1.750	1.890	3.780	
1940 41432135	-135	2	32	5.315	—	1.732	2.087	1.750	1.890	3.937	
1940 41432160	-160	2	32	6.299	—	1.732	2.087	1.750	1.890	3.937	
1940 41506095	CAT50 -SRD6A -95	1	6	3.740	2.360	0.827	1.063	2.750	1.024	1.417	
1940 41506120	-120	1	6	4.724	3.344	0.827	1.063	2.750	1.024	1.417	3.4
1940 41506160	-160	1	6	6.299	4.919	0.827	1.063	2.750	1.024	1.417	
1940 41508095	CAT50 -SRD8A -95	1	8	3.740	2.360	0.827	1.063	2.750	1.024	1.969	
1940 41508120	-120	1	8	4.724	3.344	0.827	1.063	2.750	1.024	1.969	
1940 41508160	-160	1	8	6.299	4.919	0.827	1.063	2.750	1.024	1.969	3.4
1940 41510095	CAT50 -SRD10A -95	1	10	3.740	2.360	0.945	1.260	2.750	1.260	1.969	
1940 41510120	-120	1	10	4.724	3.344	0.945	1.260	2.750	1.260	1.969	3.4
1940 41510160	-160	1	10	6.299	4.919	0.945	1.260	2.750	1.260	1.969	3.6
1940 41512095	CAT50 -SRD12A -95	1	12	3.740	2.360	0.945	1.260	2.750	1.457	2.756	
1940 41512120	-120	1	12	4.724	3.344	0.945	1.260	2.750	1.457	2.756	3.3
1940 41512160	-160	1	12	6.299	4.919	0.945	1.260	2.750	1.457	2.756	3.6
1940 41514095	CAT50 -SRD14A -95	1	14	3.740	2.360	1.063	1.339	2.750	1.457	2.756	
1940 41514120	-120	1	14	4.724	3.344	1.063	1.339	2.750	1.457	2.756	
1940 41514160	-160	1	14	6.299	4.919	1.063	1.339	2.750	1.457	2.756	3.6
1940 41516095	CAT50 -SRD16A -95	1	16	3.740	2.360	1.063	1.339	2.750	1.575	3.150	3.3
1940 41516120	-120	1	16	4.724	3.344	1.063	1.339	2.750	1.575	3.150	
1940 41516160	-160	1	16	6.299	4.919	1.063	1.339	2.750	1.575	3.150	3.6
1940 41518095	CAT50 -SRD18A -95	1	18	3.740	2.360	1.299	1.654	2.750	1.575	3.150	
1940 41518120	-120	1	18	4.724	3.344	1.299	1.654	2.750	1.575	3.150	
1940 41518160	-160	1	18	6.299	4.919	1.299	1.654	2.750	1.575	3.150	3.9
1940 41520095	CAT50 -SRD20A -95	1	20	3.740	2.360	1.299	1.654	2.750	1.654	3.937	
1940 41520120	-120	1	20	4.724	3.344	1.299	1.654	2.750	1.654	3.937	3.6
1940 41520160	-160	1	20	6.299	4.919	1.299	1.654	2.750	1.654	3.937	3.9
1940 41525105	CAT50 -SRD25A -105	1	25	4.134	2.754	1.732	2.087	2.750	1.890	4.331	
1940 41525120	-120	1	25	4.724	3.344	1.732	2.087	2.750	1.890	4.331	
1940 41525160	-160	1	25	6.299	4.919	1.732	2.087	2.750	1.890	4.331	
1940 41532105	CAT50 -SRD32A -105	1	32	4.134	2.754	1.732	2.087	2.750	1.890	4.724	
1940 41532120	-120	1	32	4.724	3.344	1.732	2.087	2.750	1.890	4.724	3.6
1940 41532160	-160	1	32	6.299	4.919	1.732	2.087	2.750	1.890	4.724	4.2

1. Siempre use herramientas de zanco de carburo con tolerancia de h6.

2. Use dos piezas de tornillos Allen opresor (incluidos) M4 x 5 (S) para cerrar los orificios vacíos en el portaherramienta cuando se use refrigerante interno.

1. Always use carbide shank tools with h6 tolerance.

2. Use 2 pcs. of M4 x 5 (S) hex. screw (included) to close air holes on the chuck when internal coolant is used.

Ejemplo para Ordenar - Ordering Example

CAT40	- SRD 0250 A	- 120
Interfaz y diámetro de husillo	Diámetro Interno	Longitud de proyección
Shank size	I.D. (d)	Projection length (L)

Ejemplo para Ordenar - Ordering Example

CAT40	- SRD 6 A	- 120
Interfaz y diámetro de husillo	Diámetro Interno	Longitud de proyección
Shank size	I.D. (d)	Projection length (L)

Tabla de dispositivos térmicos
Heating device chart

Dispositivo térmico Heating device	Portaherramienta - chuck	
	SRD6A, SRD8A SRD0250A, SRD0312A	SRD10A~SRD32A SRD0375A~SRD1500A
ISG3400	Sí / Yes	Sí / Yes
SRK-HA1, HB2	No	Sí / Yes

Pulgada a métrico → Pulgada × 25.4

Métrico a pulgada → Métrico ÷ 25.4 ó métrico por 0.03937



Tamaños especiales / personalizados bajo pedido

CAT

BT

CAT

AHO

HSK-A/E/F/C

HSK-T

C

UTS

Máquinas Especializadas

Specialized Machine

Equipo Relacionado

Related Equipment

Taladro de Biseado y de Casquillo

Bush & Chamfering Drill

Milling Chuck

Collet Holder

"R" Zero Holder

Hydraulic Chuck

Shrink Fit

Tapping Chuck

Arbors

Function Holder

Retention Stud

Tool Shank Dimensions

221

Shrink Fit (Slim Type)

- El método de contracción sujeta firmemente a una herramienta de corte al calentar y enfriar el portaherramienta. Alta precisión y mucha fuerza de fresado. (Tipo delgado)
- Shrinkage method clamps a cutting tool firmly by heating and cooling the chuck. High precision and strong Clamping force. (Slim Type)

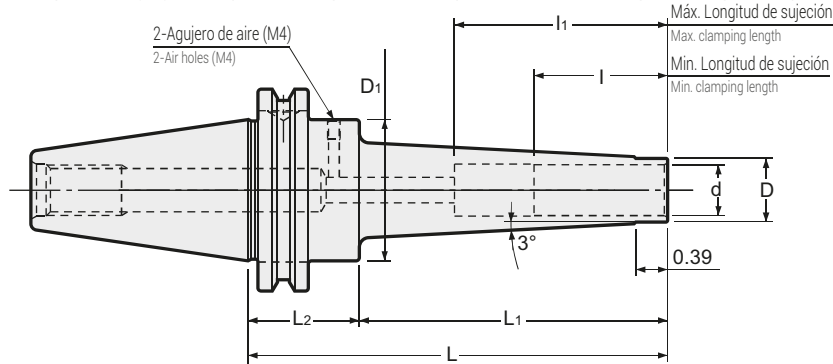

Medida en Pulgadas - Inch Sizes

Unidad : Pulgadas
Unit : Inch

Código Code	Modelo Model	d	L	L1	L2	D	D1	I1	I	kg
1940 33408105	CAT40 -SRS0250A -105	0.250	4.134	2.756	1.378	0.354	1.750	1.417	1.024	1.1
1940 33408135	-135	0.250	5.315	3.937	1.378	0.354	1.750	1.417	1.024	1.1
1940 33410105	CAT40 -SRS0312A -105	0.312	4.134	2.756	1.378	0.433	1.750	1.969	1.024	1.1
1940 33410135	-135	0.312	5.315	3.937	1.378	0.433	1.750	1.969	1.024	
1940 33412105	CAT40 -SRS0375A -105	0.375	4.134	2.756	1.378	0.512	1.750	1.969	1.260	1.1
1940 33412135	-135	0.375	5.315	3.937	1.378	0.512	1.750	1.969	1.260	1.2
1940 33412165	-165	0.375	6.496	5.118	1.378	0.512	1.750	1.969	1.260	1.3
1940 33416105	CAT40 -SRS0500A -105	0.500	4.134	2.756	1.378	0.591	1.750	2.756	1.457	1.1
1940 33416135	-135	0.500	5.315	3.937	1.378	0.591	1.750	2.756	1.457	1.2
1940 33416165	-165	0.500	6.496	5.118	1.378	0.591	1.750	2.756	1.457	1.3
1940 33420105	CAT40 -SRS0625A -105	0.625	4.134	2.756	1.378	0.787	1.750	3.150	1.575	1.1
1940 33420135	-135	0.625	5.315	3.937	1.378	0.787	1.750	3.150	1.575	1.2
1940 33420165	-165	0.625	6.496	5.118	1.378	0.787	1.750	3.150	1.575	1.4
1940 33424105	CAT40 -SRS0750A -105	0.750	4.134	2.756	1.378	1.024	1.750	3.937	1.654	1.2
1940 33424135	-135	0.750	5.315	3.937	1.378	1.024	1.750	3.937	1.654	1.4
1940 33424165	-165	0.750	6.496	5.118	1.378	1.024	1.750	3.937	1.654	1.6
1940 33508105	CAT50 -SRS0250A -105	0.250	4.134	2.756	1.378	0.354	2.750	1.417	1.024	3
1940 33508135	-135	0.250	5.315	3.937	1.378	0.354	2.750	1.417	1.024	3
1940 33508165	-165	0.250	6.496	5.118	1.378	0.354	2.750	1.417	1.024	
1940 33510105	CAT50 -SRS0312A -105	0.312	4.134	2.756	1.378	0.433	2.750	1.969	1.024	
1940 33510135	-135	0.312	5.315	3.937	1.378	0.433	2.750	1.969	1.024	
1940 33510165	-165	0.312	6.496	5.118	1.378	0.433	2.750	1.969	1.024	
1940 33512105	CAT50 -SRS0375A -105	0.375	4.134	2.756	1.378	0.512	2.750	1.969	1.260	
1940 33512135	-135	0.375	5.315	3.937	1.378	0.512	2.750	1.969	1.260	
1940 33512165	-165	0.375	6.496	5.118	1.378	0.512	2.750	1.969	1.260	3.2
1940 33512195	-195	0.375	7.677	6.299	1.378	0.512	2.750	1.969	1.260	
1940 33516105	CAT50 -SRS0500A -105	0.500	4.134	2.756	1.378	0.591	2.750	2.756	1.457	3.1
1940 33516135	-135	0.500	5.315	3.937	1.378	0.591	2.750	2.756	1.457	3.1
1940 33516165	-165	0.500	6.496	5.118	1.378	0.591	2.750	2.756	1.457	3.3
1940 33516195	-195	0.500	7.677	6.299	1.378	0.591	2.750	2.756	1.457	3.4
1940 33520105	CAT50 -SRS0625A -105	0.625	4.134	2.756	1.378	0.787	2.750	3.150	1.575	
1940 33520135	-135	0.625	5.315	3.937	1.378	0.787	2.750	3.150	1.575	3.2
1940 33520165	-165	0.625	6.496	5.118	1.378	0.787	2.750	3.150	1.575	
1940 33520195	-195	0.625	7.677	6.299	1.378	0.787	2.750	3.150	1.575	
1940 33524105	CAT50 -SRS0750A -105	0.750	4.134	2.756	1.378	1.024	2.750	3.937	1.654	
1940 33524135	-135	0.750	5.315	3.937	1.378	1.024	2.750	3.937	1.654	
1940 33524165	-165	0.750	6.496	5.118	1.378	1.024	2.750	3.937	1.654	3.5
1940 33524195	-195	0.750	7.677	6.299	1.378	1.024	2.750	3.937	1.654	

1. Siempre use herramientas de zanco de carburo con tolerancia de h6.

2. Use dos piezas de tornillos Allen (incluidos) M4 x 5 (S) para cerrar los orificios vacíos en el portaherramienta cuando se use refrigerante interno.

1. Always use carbide shank tools with h6 tolerance.

2. Use 2pcs. of M4 x 5 (S) hex. screw (included) to close air holes on the chuck when internal coolant is used.

Ejemplo para Ordenar - Ordering Example

CAT40 - SRS 0250 A - 105

Interfaz y
diámetro de husillo

Shank size

Diámetro
Interno

I.D. (d)

Longitud de
proyección

Projection
length (L)

Medidas Métricas - Metric Sizes

Unidad : Pulgadas
Unit : Inch

Código Code	Modelo Model	d (mm)	L	L1	L2	D	D1	I1	I	kg
1940 31406105	CAT40 -SRS6A -105	6	4.134	2.756	1.378	0.354	1.750	1.417	1.024	1.0
1940 31406135	-135	6	5.315	3.937	1.378	0.354	1.750	1.417	1.024	
1940 31408105	CAT40 -SRS8A -105	8	4.134	2.756	1.378	0.433	1.750	1.969	1.024	1.1
1940 31408135	-135	8	5.315	3.937	1.378	0.433	1.750	1.969	1.024	
1940 31410105	CAT40 -SRS10A -105	10	4.134	2.756	1.378	0.512	1.750	1.969	1.260	1.1
1940 31410135	-135	10	5.315	3.937	1.378	0.512	1.750	1.969	1.260	
1940 31410165	-165	10	6.496	5.118	1.378	0.512	1.750	1.969	1.260	
1940 31412105	CAT40 -SRS12A -105	12	4.134	2.756	1.378	0.591	1.750	2.756	1.457	1.1
1940 31412135	-135	12	5.315	3.937	1.378	0.591	1.750	2.756	1.457	
1940 31412165	-165	12	6.496	5.118	1.378	0.591	1.750	2.756	1.457	1.3
1940 31416105	CAT40 -SRS16A -105	16	4.134	2.756	1.378	0.787	1.750	3.150	1.575	
1940 31416135	-135	16	5.315	3.937	1.378	0.787	1.750	3.150	1.575	
1940 31416165	-165	16	6.496	5.118	1.378	0.787	1.750	3.150	1.575	
1940 31420105	CAT40 -SRS20A -105	20	4.134	2.756	1.378	1.024	1.750	3.937	1.654	
1940 31420135	-135	20	5.315	3.937	1.378	1.024	1.750	3.937	1.654	
1940 31420165	-165	20	6.496	5.118	1.378	1.024	1.750	3.937	1.654	
1940 31506105	CAT50 -SRS6A -105	6	4.134	2.756	1.378	0.354	2.750	1.417	1.024	
1940 31506135	-135	6	5.315	3.937	1.378	0.354	2.750	1.417	1.024	
1940 31506165	-165	6	6.496	5.118	1.378	0.354	2.750	1.417	1.024	
1940 31508105	CAT50 -SRS8A -105	8	4.134	2.756	1.378	0.433	2.750	1.969	1.024	
1940 31508135	-135	8	5.315	3.937	1.378	0.433	2.750	1.969	1.024	
1940 31508165	-165	8	6.496	5.118	1.378	0.433	2.750	1.969	1.024	
1940 31510105	CAT50 -SRS10A -105	10	4.134	2.756	1.378	0.512	2.750	1.969	1.260	3.0
1940 31510135	-135	10	5.315	3.937	1.378	0.512	2.750	1.969	1.260	
1940 31510165	-165	10	6.496	5.118	1.378	0.512	2.750	1.969	1.260	
1940 31510195	-195	10	7.677	6.299	1.378	0.512	2.750	1.969	1.260	3.3
1940 31512105	CAT50 -SRS12A -105	12	4.134	2.756	1.378	0.591	2.750	2.756	1.457	
1940 31512135	-135	12	5.315	3.937	1.378	0.591	2.750	2.756	1.457	3.1
1940 31512165	-165	12	6.496	5.118	1.378	0.591	2.750	2.756	1.457	
1940 31512195	-195	12	7.677	6.299	1.378	0.591	2.750	2.756	1.457	3.4
1940 31516105	CAT50 -SRS16A -105	16	4.134	2.756	1.378	0.787	2.750	3.150	1.575	
1940 31516135	-135	16	5.315	3.937	1.378	0.787	2.750	3.150	1.575	
1940 31516165	-165	16	6.496	5.118	1.378	0.787	2.750	3.150	1.575	3.4
1940 31516195	-195	16	7.677	6.299	1.378	0.787	2.750	3.150	1.575	
1940 31520105	CAT50 -SRS20A -105	20	4.134	2.756	1.378	1.024	2.750	3.937	1.654	
1940 31520135	-135	20	5.315	3.937	1.378	1.024	2.750	3.937	1.654	
1940 31520165	-165	20	6.496	5.118	1.378	1.024	2.750	3.937	1.654	
1940 31520195	-195	20	7.677	6.299	1.378	1.024	2.750	3.937	1.654	

1. Siempre use herramientas de zanco de carburo con tolerancia de h6.
 2. Use dos piezas de tornillos Allen (incluidos) M4 x 5 (S) para cerrar los orificios vacíos en el portaherramienta cuando se use refrigerante interno.
1. Always use carbide shank tools with h6 tolerance.
 2. Use 2pcs. of M4 x 5 (S) hex. screw (included) to close air holes on the chuck when internal coolant is used.

Tabla de dispositivos térmicos Heating device chart		
Dispositivo térmico Heating device	Portaherramienta - chuck	
	SRS0250A, SRS0312A SRS6A, SRS8A	SRS0375A~SRS0750A SRS10A~SRS20A
ISG3400	Sí / Yes	Sí / Yes
SRK-HA1, HB2	No	Sí / Yes

Ejemplo para Ordenar - Ordering Example

CAT40 - SRS 12 A - 105

Interfaz y diámetro de husillo
Shank size

Diámetro Interno
I.D. (d)

Longitud de proyección
Projection length (L)

Synchronous Tap Holder With Easy Tool Length Adjustment

- La longitud de proyección de la herramienta de corte se puede ajustar simplemente girando la circunferencia del portaherramienta.
- Projection length of the cutting tool can be adjusted by simply turning circumference of the holder.

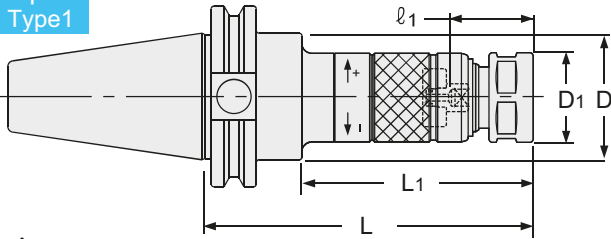
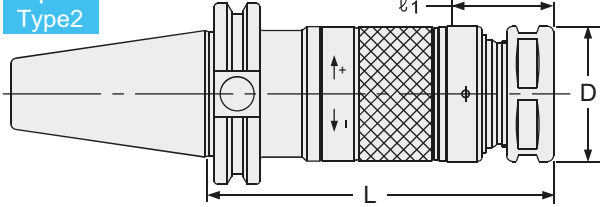
Tipo1
Type1Tipo2
Type2

Para consultar las medidas de machuelo adecuados, favor de dirigirse a la tabla en las pág. 485-486.
For capable tap sizes, please refer to P.485-486 chart.

(NOTA) El D.E. de la tuerca del STM8 es de 0.748".

(NOTE) Nut O.D. of STM8 is 0.748".

Unidad : Pulgadas
Unit : Inch

Portaherramientas STM
STM Holder+ Boquilla
Collet+ Unidad STS
STS Driver

Código Code	Modelo Model	Tipo Type	Medida de machuelo Tap Size	L	L1	D	D1	kg	Tuerca ciega Nut	Boquilla Collet	Unidad preajustada Preset Driver	Llave Inglesa Spanner
1880 00400090	CAT40 -STM8 -90 *	1		3.543	2.126	1.752	0.827					
1880 00400105	-105	1	Old JIS Taps	4.134	2.717	1.752	0.827	1.1				
1880 00400120	-120	1	M4-8 U No8-5/16	4.724	3.307	1.752	0.827	1.2	KDP-1414	FDC-07	STS-8	Llave con 17 mm de ancho (Flat 17mm width)
1880 00400135	-135	1	OSG Synchro Taps	5.315	4.291	1.752	0.827	1.2				
1880 00400150	-150	1	M4-6	5.906	4.882	1.752	0.827					
1880 10400090	CAT40 -STM12 -90 *	1		3.543	2.126	1.752	1.024	1.2				
1880 10400105	-105	1	Old JIS Taps	4.134	2.717	1.752	1.024	1.2				
1880 10400120	-120	1	M4-12 U No8-7/16	4.724	3.307	1.752	1.024	1.2	HTP-09	FSC-09	STS-12	S-1L
1880 10400135	-135	1	PT1/8	5.315	4.291	1.752	1.024	1.3				
1880 10400150	-150	1	OSG Synchro Taps	5.906	4.882	1.752	1.024					
1880 10400180	-180	1	M4-10	7.087	6.063	1.752	1.024					
1880 30400105	CAT40 -STM18 -105	1		4.134	2.717	1.752	1.417	1.3				
1880 30400120	-120	1	Old JIS Taps	4.724	3.307	1.752	1.417	1.4				
1880 30400135	-135	1	M14-18 U1/2-3/4	5.315	4.291	1.752	1.417	1.5	HTP-16	FSC-16	STS-18	S-4L
1880 30400150	-150	1	PT1/4-3/8	5.906	4.882	1.752	1.417					
1880 30400180	-180	1	OSG Synchro Taps	7.087	6.063	1.752	1.417					
1880 40400120	CAT40 -STM30 -120	2		4.724	—	1.811	—	1.6				
1880 40400135	-135	2	Old JIS Taps	5.315	—	1.811	—	1.8				
1880 40400150	-150	2	M20-30 U7/8-1-1/8	5.906	—	1.811	—	1.9	HTP-22	FSC-22	STS-30	S-5L
1880 40400180	-180	2	PT1/2-3/4	7.087	—	1.811	—					
1880 00500090	CAT50 -STM8 -90 *	1		3.543	2.126	2.752	0.827					
1880 00500105	-105	1	Old JIS Taps	4.134	2.717	2.752	0.827	3.1				
1880 00500120	-120	1	M4-8 U No8-5/16	4.724	3.307	2.752	0.827	3.1	KDP-1414	FDC-07	STS-8	Llave con 17 mm de ancho (Flat 17mm width)
1880 00500135	-135	1	OSG Synchro Taps	5.315	4.291	2.752	0.827	3.2				
1880 00500150	-150	1	M4-6	5.906	4.882	2.752	0.827					
1880 00500165	-165	1		6.496	5.472	2.752	0.827					
1880 10500090	CAT50 -STM12 -90 *	1		3.543	2.126	2.752	1.024					
1880 10500105	-105	1	Old JIS Taps	4.134	2.717	2.752	1.024	3.2				
1880 10500120	-120	1	M4-12 U No8-7/16	4.724	3.307	2.752	1.024	3.2	HTP-09	FSC-09	STS-12	S-1L
1880 10500135	-135	1	PT1/8	5.315	4.291	2.752	1.024	3.3				
1880 10500150	-150	1	OSG Synchro Taps	5.906	4.882	2.752	1.024					
1880 10500180	-180	1	M4-10	7.087	6.063	2.752	1.024	3.4				
1880 30500105	CAT50 -STM18 -105	1		4.134	2.717	2.752	1.417	3.3				
1880 30500120	-120	1	Old JIS Taps	4.724	3.307	2.752	1.417	3.4				
1880 30500135	-135	1	M14-18 U1/2-3/4	5.315	4.291	2.752	1.417	3.5	HTP-16	FSC-16	STS-18	S-4L
1880 30500150	-150	1	PT1/4-3/8	5.906	4.882	2.752	1.417					
1880 30500180	-180	1	OSG Synchro Taps	7.087	6.063	2.752	1.417	3.8				
1880 40500120	CAT50 -STM30 -120	1		4.724	3.307	2.752	1.811	3.5				
1880 40500135	-135	1	Old JIS Taps	5.315	4.291	2.752	1.811	3.7				
1880 40500150	-150	1	M20-30 U7/8-1-1/8	5.906	4.882	2.752	1.811	3.9	HTP-22	FSC-22	STS-30	S-5L
1880 40500180	-180	1	PT1/2-3/4	7.087	6.063	2.752	1.811					
1880 40500210	-210	1	OSG Synchro Taps	8.268	7.244	2.752	1.811					

1. La boquilla, la llave inglesa y la unidad preajustada se venden por separado.

2. Continuar en la siguiente página para conocer la dimensión ℓ_1 .

3. El STM8 puede hacer orificios de machuelo menores a M4.
Las boquillas a usar son como se especifica a continuación.

M1-M2.6: FDC-03007-*** M3-M3.5: FDC-04007-***

La boquilla del machuelo no se usará para los usos antes mencionados.

1. Collet, spanner and preset driver are sold separately.

2. Please see next page for ℓ_1 dimension.

3. Tap holes smaller than M4 can be made by STM8. Collets to be used are as follows.

M1-M2.6: FDC-03007-*** M3-M3.5: FDC-04007-***

Tap drive will not be used for the above usages.

Ejemplo para Ordenar - Ordering Example

CAT40	-	STM	8	-	90
Interfaz y diámetro de husillo Shank size		Medida de portaherramienta Holder size			Longitud de proyección Projection length (L)

Dimensión ℓ1 para el STM - ℓ1 Dimension for STM

Machuelos JIS antiguas - Old JIS Taps (Unidad : Pulgadas / Unit : Inch)

Sin vena de refrigerante a través del centro Without center-through coolant			Con vena de refrigerante a través del centro With center-through coolant (STM12~30)		
Medida de machuelo - Tap Size	ℓ1	ℓ1(*)	Medida de machuelo - Tap Size	ℓ1	ℓ1(*)
M4 ~ 6 U No.8 ~ 1/4	0.82 ~ 1.37	0.82 ~ 1.02	M4 ~ 6 U No.8 ~ 1/4	0.94 ~ 1.37	0.94 ~ 1.02
M7 ~ 12 U 5/16 ~ U7/16 PT1/8	0.90 ~ 1.45	0.90 ~ 1.10	M7 ~ 10 U 5/16 ~ 3/8	0.98 ~ 1.45	0.98 ~ 1.10
M13 ~ 15 U 1/2 ~ 5/8 PT1/4	1.10 ~ 1.65	—	M11 ~ 12 U 7/16 PT 1/8	1.02 ~ 1.45	1.02 ~ 1.10
M16 ~ 17	1.25 ~ 1.77	—	U1/2	1.25 ~ 1.65	—
M18 ~ 27 U 3/4 ~ U1 PT3/8 ~ 5/8	1.29 ~ 1.85	—	M13 ~ 15 U9/16	1.29 ~ 1.65	—
M30 U1-1/8 PT3/4	1.49 ~ 2.04	—	U5/8 PT1/4	1.33 ~ 1.65	—
			M16	1.37 ~ 1.81	—
Con suministro de refrigerante a través del centro With center-through coolant (STM8)			M18 U 3/4 PT3/8	1.41 ~ 1.85	—
Medida de machuelo - Tap Size	ℓ1	ℓ1(*)	M20 ~ 21 PT1/2	1.57 ~ 1.85	—
M4 ~ 6 U No.8 ~ 1/4	0.98 ~ 1.37	0.98 ~ 1.02	M22 U 7/8	1.61 ~ 1.85	—
M7 ~ 8 U5/16	1.02 ~ 1.45	1.02 ~ 1.10	M23	1.65 ~ 1.85	—
			M24 ~ 25 PT5/8	1.69 ~ 1.85	—
			M26 ~ 27 U1	1.73 ~ 1.85	—
			M28	1.77 ~ 2.04	—
			M30 PT3/4	1.81 ~ 2.04	—
			U 1-1/8	1.88 ~ 2.04	—

Machuelos sincronizados OSG - OSG Synchro Taps

(Unidad Pulgadas / Unit : Inch)

Sin vena de refrigerante a través del centro Without center-through coolant			Con vena de refrigerante a través del centro With center-through coolant (STM8)		
Medida de machuelo - Tap Size	ℓ1	ℓ1(*)	Medida de machuelo - Tap Size	ℓ1	ℓ1(*)
M4 ~ 6	0.82 ~ 1.37	0.82 ~ 1.02	M4 ~ 6	0.98 ~ 1.37	0.98 ~ 1.02
M8 ~ 10	0.90 ~ 1.45	0.90 ~ 1.10			
M12 ~ 14	1.10 ~ 1.65	—			
M16 ~ 27	1.29 ~ 1.85	—			
Con vena de refrigerante a través del centro With center-through coolant (STM12~30)					
Medida de machuelo - Tap Size	ℓ1	ℓ1(*)			
M4 ~ 6	0.94 ~ 1.37	0.94 ~ 1.02			
M8 ~ 10	1.02 ~ 1.45	1.02 ~ 1.10			
M12	1.29 ~ 1.65	—			
M14	1.33 ~ 1.65	—			
M16 ~ 20	1.57 ~ 1.81	—			
M22 ~ 27	1.73 ~ 1.85	—			

YAMAWA X Series (Unidad Pulgadas / Unit : Inch)

Sin vena de refrigerante a través del centro Without center-through coolant			Con vena de refrigerante a través del centro With center-through coolant (STM8)		
Medida de machuelo - Tap Size	ℓ1	ℓ1(*)	Medida de machuelo - Tap Size	ℓ1	ℓ1(*)
M6 M8 M10 M12	0.90 ~ 1.45 1.10 ~ 1.65	0.90 ~ 1.10 —	M6	1.02 ~ 1.45	1.02 ~ 1.10
Con vena de refrigerante a través del centro With center-through coolant (STM12~30)					
Medida de machuelo - Tap Size	ℓ1	ℓ1(*)			
M6	0.98 ~ 1.45	0.98 ~ 1.10			
M8	1.02 ~ 1.45	1.02 ~ 1.10			
M10	1.29 ~ 1.65	—			
M12	1.33 ~ 1.65	—			

BT

CAT

AHO

HSK-A/E/F/C

HSK-T

C

UTS

Máquinas Especializadas

Specialized Machine

Equipo Relacionado

Related Equipment

Taladro de Biselado & de Casquillo

Bush & Chamfering Drill

Milling Chuck

Collet Holder

"R" Zero Holder

Hydraulic Chuck

Shrink Fit

Tapping Chuck

Arbors

Function Holder

Retention Stud

Tool Shank Dimensions

Tabla de referencia de las medidas de machuelo (boquilla, conductor de preajuste)

Tap size reference chart (collet, preset driver)

FDC ó/lor FSC - boquilla (collet)

Unidad de cambio del conductor de preajuste y herramienta
Preset driver & tool for changing driver

Tipo OH - Type OH

● La boquilla OH debe usarse para el abastecimiento de refrigerante a través del centro y para el abastecimiento de refrigerante externo.
● OH type collet should be used for center-through coolant feeding and external coolant feeding.

Tipo C - Type C

● Cuando se necesita el abastecimiento de refrigerante "a través de los costados de la boquilla"
● when "collet-through" coolant feeding is needed.

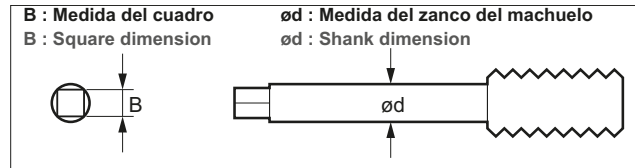
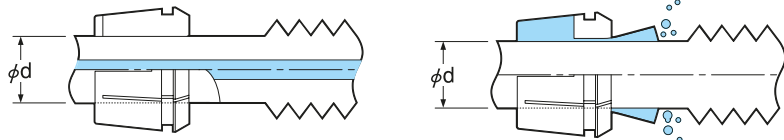

Favor de elegir el tipo OH para un uso sin refrigerante.
Please select OH type for non-coolant use.

Tipo STS - Type STS

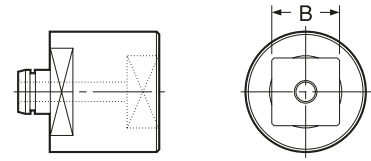

Tipo STS-R - Type STS

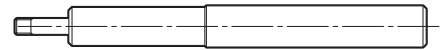

Modelo de portaherramienta Holder Model	Medida de machuelo Tap Size (ANSI)	ød (Pulgada-Inch)	ød (mm)	Modelo de Boquilla Collet Model (OH or C)	B (Pulgada-Inch)	B (mm)	Conductor de preajuste Preset Driver
STM8	#0-6	0.141	3.5814	FDC-03607**	0.110	2.794	STS8- □ 2.8
	#8	0.168	4.2672	FDC-04307**	0.131	3.3274	STS8- □ 3.4
	#10	0.194	4.9276	FDC-05007**	0.152	3.8608	STS8- □ 4.0
	#12	0.22	5.588	FDC-05607**	0.165	4.191	STS8- □ 4.2
	1/4	0.255	6.477	FDC-06507**	0.191	4.8514	STS8- □ 5.0
STM12	#0-6	0.141	3.5814	FSC-09-3.6**	0.110	2.794	STS12- □ 2.8
	#8	0.168	4.2672	FSC-09-4.3**	0.131	3.3274	STS12- □ 3.4
	#10	0.194	4.9276	FSC-09-5.0**	0.152	3.8608	STS12- □ 4.0
	#12	0.22	5.588	FSC-09-5.6**	0.165	4.191	STS12- □ 4.2
	1/4	0.255	6.477	FSC-09-6.5**	0.191	4.8514	STS12- □ 5.0
	1/8SPT	0.313	7.9502	FSC-09-8.0**	0.234	5.9436	STS12- □ 6.0
	5/16	0.318	8.0772	FSC-09-8.1**	0.238	6.0452	STS12- □ 6.1
STM18	7/16	0.323	8.2042	FSC-09-8.3**	0.242	6.1468	STS12- □ 6.2
	1/2	0.367	9.3218	FSC-16-9.4**	0.275	6.985	STS18- □ 7.0
	3/8	0.381	9.6774	FSC-16-9.7**	0.286	7.2644	STS18- □ 7.3
	9/16	0.429	10.8966	FSC-16-10.9**	0.322	8.1788	STS18- □ 8.2
	1/8LPT	0.437	11.0998	FSC-16-11.1**	0.328	8.3312	STS18- □ 8.4
	5/8	0.48	12.192	FSC-16-12.2**	0.360	9.144	STS18- □ 9.2
	11/16	0.542	13.7668	FSC-16-13.8**	0.406	10.3124	STS18- □ 10.4
STM30	1/4PT	0.562	14.2748	FSC-16-14.3**	0.421	10.6934	STS18- □ 10.7
	3/4	0.59	14.986	FSC-22-15.0**	0.442	11.2268	STS30- □ 11.3
	13/16	0.652	16.5608	FSC-22-16.6**	0.489	12.4206	STS30- □ 12.5
	7/8	0.697	17.7038	FSC-22-17.8**	0.523	13.2842	STS30- □ 13.3
	3/8PT	0.7	17.78	FSC-22-17.8**	0.531	13.4874	STS30- □ 13.5
	1	0.8	20.32	FSC-22-20.4**	0.600	15.24	STS30- □ 15.3

Para DIN e ISO, favor de dirigirse a la pág. 485-486.
For DIN and ISO, please refer to P. 485-486.

Ejemplo para Ordenar - Ordering Example

FSC - 22 - 20.4 - OH

Medida de la boquilla
Collet size

D.I. de la boquilla
Collet I.D. (d)

OH: Para herramienta con vena de lubricación

C: Para refrigeración a través de los costados de la boquilla

OH: For tool with coolant hole

C: For collet through

Combinación de accesorios - Accessories combination

Portaherramienta para machuelo - Tap holder		Boquilla Collet		Conductor de preajuste Preset Driver		Tuerca ciega Nut		Unidad de cambio de herramienta Tool changing driver		Llave Inglesa Spanner	
Modelo Model	Modelo Model	Modelo Model	Código Code	Modelo Model	Código Code	Modelo Model	Código Code	Modelo Model	Código Code	Modelo Model	Código Code
STM8	FDC-07	STS8	3914 0100**03	KDP-1414	0070 01001407	STS-R0	3914 00000006	Llave con 17 mm de ancho (Flat 17mm width)			
STM12	FSC-09	STS12	3914 1100**03	HTP-09	1314 00000009	STS-R1	3914 10000006	S-1L	0803 00000011		
STM18	FSC-16	STS18	3914 310***03	HTP-16	1314 00000016	STS-R2	3914 30000006	S-4L	0803 00000014		
STM30	FSC-22	STS30	3914 410***03	HTP-22	1314 00000022	STS-R2	3914 30000006	S-5L	0803 00000015		

Tabla de referencia de los tamaños de machuelo (boquilla, conductor de preajuste)

Tap size reference chart (collet, preset driver)

FDC ó/or FSC - boquilla (collet)

OH Tipo - Type OH

● La boquilla OH debe usarse para el abastecimiento de refrigerante a través del centro y para el abastecimiento de refrigerante externo.
● OH type collet should be used for center-through coolant feeding and external coolant feeding.

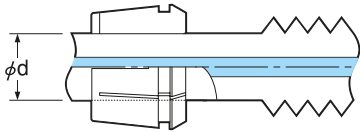

C Tipo - Type C

● Cuando se necesita el abastecimiento de refrigerante "a través de la boquilla"
● when "collet-through" coolant feeding is needed.

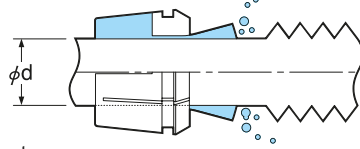

Favor de elegir el tipo OH para un uso sin refrigerante.
Please select OH type for non-coolant use.

Unidad de cambio del conductor de preajuste y herramienta Preset driver & tool for changing driver

STS Tipo - Type STS

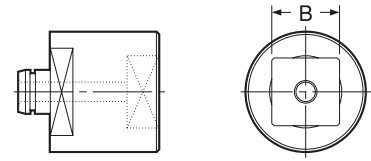

STS-R Tipo - Type STS

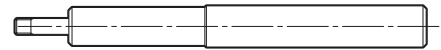

Modelo de portaherramienta Holder Model	Medida de machuelo - Tap Size					ød	Modelo de Boquilla Collet Model (OH or C)	B	Conductor de preajuste Preset Driver	Herramienta para cambiar la unidad preajustada/Tool for Changing Driver
	Estándar JIS viejo - Old JIS Taps			Machuelo sincronizado OSG-OSG Synchro-Taps	YAMAWA X Series					
	Rosca métrica Metric Thread	Rosca unificada Unified Thread	Rosca de tubo ahusado/Pipe Taper Thread							
STM8	M4-M4.5	UNo.8				5.0	FDC-05007-**	4.0	STS8-□4.0	STS-R0
	M5-M5.5	UNo.10~12				5.5	FDC-05507-**	4.5	STS8-□4.5	STS-R0
	M6	U1/4		M4-M6		6.0	FDC-06007-**	4.5	STS8-□4.5	STS-R0
					M6	6.0	FDC-06007-**	4.9	STS8-□4.9	STS-R0
		U5/16				6.1	FDC-06107-**	5.0	STS8-□5.0	STS-R0
		M7-8				6.2	FDC-06207-**	5.0	STS8-□5.0	STS-R0
STM12	M4-M4.5	UNo.8				5.0	FSC-09-5.0-**	4.0	STS12-□4.0	STS-R1
	M5-M5.5	UNo.10~12				5.5	FSC-09-5.5-**	4.5	STS12-□4.5	STS-R1
	M6	U1/4		M4-M6		6.0	FSC-09-6.0-**	4.5	STS12-□4.5	STS-R1
					M6	6.0	FSC-09-6.0-**	4.9	STS12-□4.9	STS-R1
		U5/16				6.1	FSC-09-6.1-**	5.0	STS12-□5.0	STS-R1
		M7-8				6.2	FSC-09-6.2-**	5.0	STS12-□5.0	STS-R1
		M9-M10	U3/8			7.0	FSC-09-7.0-**	5.5	STS12-□5.5	STS-R1
					M8	8.0	FSC-09-8.0-**	6.2	STS12-□6.2	STS-R1
		M11	U7/16	PT1/16~1/8	M8-M10	8.0	FSC-09-8.0-**	6.0	STS12-□6.0	STS-R1
		M12				8.5	FSC-09-8.5-**	6.5	STS12-□6.5	STS-R1
STM18		U1/2				9.0	FSC-16-9.0-**	7.0	STS18-□7.0	STS-R2
	M13					9.5	FSC-16-9.5-**	7.0	STS18-□7.0	STS-R2
				M12	M10	10.0	FSC-16-10.0-**	8.0	STS18-□8.0	STS-R2
	M14~15	U9/16				10.5	FSC-16-10.5-**	8.0	STS18-□8.0	STS-R2
			PT1/4			11.0	FSC-16-11.0-**	9.0	STS18-□9.0	STS-R2
		U5/8		M14	M12	12.0	FSC-16-12.0-**	9.0	STS18-□9.0	STS-R2
		M16				12.5	FSC-16-12.5-**	10.0	STS18-□10.0	STS-R2
		M17				13.0	FSC-16-13.0-**	10.0	STS18-□10.0	STS-R2
STM30	M18~M19	U3/4	PT3/8			14.0	FSC-16-14.0-**	11.0	STS18-□11.0	STS-R2
	M20					15.0	FSC-22-15.0-**	12.0	STS30-□12.0	STS-R2
	M21			M16-M20		16.0	FSC-22-16.0-**	12.0	STS30-□12.0	STS-R2
	M22	U7/8				17.0	FSC-22-17.0-**	13.0	STS30-□13.0	STS-R2
	M23		PT1/2			18.0	FSC-22-18.0-**	14.0	STS30-□14.0	STS-R2
	M24~M25		PT5/8			19.0	FSC-22-19.0-**	15.0	STS30-□15.0	STS-R2
	M26-M27	U1		M22-M27		20.0	FSC-22-20.0-**	15.0	STS30-□15.0	STS-R2
	M28					21.0	FSC-22-21.0-**	17.0	STS30-□17.0	STS-R2
		U1-1/8				22.0	FSC-22-22.0-**	17.0	STS30-□17.0	STS-R2
		M30		PT3/4		23.0	FSC-22-23.0-**	17.0	STS30-□17.0	STS-R2

Ejemplo para Ordenar - Ordering Example

FSC - 22 - 20.0 - OH

Medida de la boquilla
Collet size

D.I. de la boquilla
Collet I.D. (d)

OH: Para herramienta con vena de refrigerante
C: Para refrigerante a través de los costados boquilla
OH: For tool with coolant hole
C: For collet through

Combinación de accesorios - Accessories combination

Portaherramienta para machuelo - Tap holder	Boquilla Collet	Conductor de preajuste Preset Driver		Tuerca ciega Nut		Unidad de cambio de herramienta Tool changing driver		Llave Inglesa Spanner	
Modelo Model	Modelo Model	Modelo Model	Código Code	Modelo Model	Código Code	Modelo Model	Código Code	Modelo Model	Código Code
STM8	FDC-07	STS8	3914 0100**03	KDP-444	0070 01001407	STS-R0	3914 00000006	Llave con 17 mm de ancho (Flat 17mm width)	
STM12	FSC-09	STS12	3914 1100**03	HTP-09	1314 00000009	STS-R1	3914 10000006	S-1L	0803 00000011
STM18	FSC-16	STS18	3914 310***03	HTP-16	1314 00000016	STS-R2	3914 30000006	S-4L	0803 00000014
STM30	FSC-22	STS30	3914 410***03	HTP-22	1314 00000022	STS-R2	3914 30000006	S-5L	0803 00000015

Boquilla para machuelo - Collet For Tapper

FSC-OH

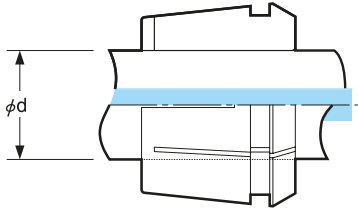
Para herramienta con orificio para refrigerante
For tool with coolant hole

Diá. del zanco de la herramienta -Tool Shank Dia.		Medida Size	Código Code
ϕd (inch)	ϕd (mm)		
ϕ 0.141	ϕ 3.6	FSC-09-3.6-OH	—
ϕ 0.168	ϕ 4.3	FSC-09-4.3-OH	1334 00104309
ϕ 0.194	ϕ 5.0	FSC-09-5.0-OH	1334 00105009
ϕ 0.220	ϕ 5.6	FSC-09-5.6-OH	1334 00105609
ϕ 0.216	ϕ 5.5	FSC-09-5.5-OH	1334 00105509
ϕ 0.236	ϕ 6.0	FSC-09-6.0-OH	1334 00106009
ϕ 0.240	ϕ 6.1	FSC-09-6.1-OH	1334 00106109
ϕ 0.244	ϕ 6.2	FSC-09-6.2-OH	1334 00106209
ϕ 0.255	ϕ 6.5	FSC-09-6.5-OH	1334 00106509
ϕ 0.275	ϕ 7.0	FSC-09-7.0-OH	1334 00107009
ϕ 0.314	ϕ 8.0	FSC-09-8.0-OH	1334 00108009
ϕ 0.313	ϕ 8.0	FSC-09-8.0-OH	1334 00108009
ϕ 0.318	ϕ 8.1	FSC-09-8.1-OH	1334 00108109
ϕ 0.323	ϕ 8.3	FSC-09-8.3-OH	1334 00108309
ϕ 0.334	ϕ 8.5	FSC-09-8.5-OH	1334 00108509
ϕ 0.354	ϕ 9.0	FSC-16-9.0-OH	1334 00109016
ϕ 0.367	ϕ 9.4	FSC-16-9.4-OH	1334 00109416
ϕ 0.374	ϕ 9.5	FSC-16-9.5-OH	1334 00109516
ϕ 0.381	ϕ 9.7	FSC-16-9.7-OH	1334 00109716
ϕ 0.393	ϕ 10.0	FSC-16-10.0-OH	1334 00110016
ϕ 0.413	ϕ 10.5	FSC-16-10.5-OH	1334 00110516
ϕ 0.429	ϕ 10.9	FSC-16-10.9-OH	1334 00110916
ϕ 0.433	ϕ 11.0	FSC-16-11.0-OH	1334 00111016
ϕ 0.437	ϕ 11.1	FSC-16-11.1-OH	1334 00111116
ϕ 0.472	ϕ 12.0	FSC-16-12.0-OH	1334 00112016
ϕ 0.480	ϕ 12.2	FSC-16-12.2-OH	1334 00112216
ϕ 0.492	ϕ 12.5	FSC-16-12.5-OH	1334 00112516
ϕ 0.511	ϕ 13.0	FSC-16-13.0-OH	1334 00113016
ϕ 0.542	ϕ 13.8	FSC-16-13.8-OH	1334 00113816
ϕ 0.551	ϕ 14.0	FSC-16-14.0-OH	1334 00114016
ϕ 0.562	ϕ 14.3	FSC-16-14.3-OH	1334 00114316
ϕ 0.590	ϕ 15.0	FSC-22-15.0-OH	1334 00115022
ϕ 0.629	ϕ 16.0	FSC-22-16.0-OH	1334 00116022
ϕ 0.652	ϕ 16.6	FSC-22-16.6-OH	1334 00116622
ϕ 0.669	ϕ 17.0	FSC-22-17.0-OH	1334 00117022
ϕ 0.697	ϕ 17.8	FSC-22-17.8-OH	1334 00117822
ϕ 0.700	ϕ 17.8	FSC-22-17.8-OH	1334 00117822
ϕ 0.708	ϕ 18.0	FSC-22-18.0-OH	1334 00118022
ϕ 0.748	ϕ 19.0	FSC-22-19.0-OH	1334 00119022
ϕ 0.800	ϕ 20.4	FSC-22-20.4-OH	1334 00120422
ϕ 0.787	ϕ 20.0	FSC-22-20.0-OH	1334 00120022
ϕ 0.826	ϕ 21.0	FSC-22-21.0-OH	1334 00121022
ϕ 0.866	ϕ 22.0	FSC-22-22.0-OH	1334 00122022
ϕ 0.905	ϕ 23.0	FSC-22-23.0-OH	1334 00123022

FSC-C

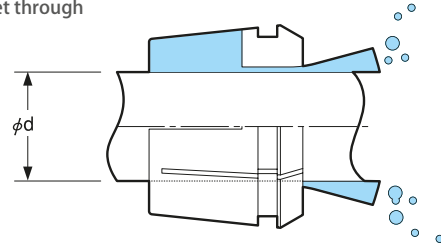
Para refrigerante a través de la boquilla
For Collet through

Diá. del zanco de la herramienta -Tool Shank Dia.		Medida Size	Código Code
ϕd (inch)	ϕd (mm)		
ϕ 0.141	ϕ 3.6	FSC-09-3.6-C	—
ϕ 0.168	ϕ 4.3	FSC-09-4.3-C	1335 00104309
ϕ 0.194	ϕ 5.0	FSC-09-5.0-C	1335 00105009
ϕ 0.220	ϕ 5.6	FSC-09-5.6-C	1335 00105609
ϕ 0.216	ϕ 5.5	FSC-09-5.5-C	1335 00105509
ϕ 0.236	ϕ 6.0	FSC-09-6.0-C	1335 00106009
ϕ 0.240	ϕ 6.1	FSC-09-6.1-C	1335 00106109
ϕ 0.244	ϕ 6.2	FSC-09-6.2-C	1335 00106209
ϕ 0.255	ϕ 6.5	FSC-09-6.5-C	1335 00106509
ϕ 0.275	ϕ 7.0	FSC-09-7.0-C	1335 00107009
ϕ 0.314	ϕ 8.0	FSC-09-8.0-C	1335 00108009
ϕ 0.313	ϕ 8.0	FSC-09-8.0-C	1335 00108009
ϕ 0.318	ϕ 8.1	FSC-09-8.1-C	1335 00108109
ϕ 0.323	ϕ 8.3	FSC-09-8.3-C	1335 00108309
ϕ 0.334	ϕ 8.5	FSC-09-8.5-C	1335 00108509
ϕ 0.354	ϕ 9.0	FSC-16-9.0-C	1335 00109016
ϕ 0.367	ϕ 9.4	FSC-16-9.4-C	1335 00109416
ϕ 0.374	ϕ 9.5	FSC-16-9.5-C	1335 00109516
ϕ 0.381	ϕ 9.7	FSC-16-9.7-C	1335 00109716
ϕ 0.393	ϕ 10.0	FSC-16-10.0-C	1335 00110016
ϕ 0.413	ϕ 10.5	FSC-16-10.5-C	1335 00110516
ϕ 0.429	ϕ 10.9	FSC-16-10.9-C	1335 00110916
ϕ 0.433	ϕ 11.0	FSC-16-11.0-C	1335 00111016
ϕ 0.437	ϕ 11.1	FSC-16-11.1-C	1335 00111116
ϕ 0.472	ϕ 12.0	FSC-16-12.0-C	1335 00112016
ϕ 0.480	ϕ 12.2	FSC-16-12.2-C	1335 00112216
ϕ 0.492	ϕ 12.5	FSC-16-12.5-C	1335 00112516
ϕ 0.511	ϕ 13.0	FSC-16-13.0-C	1335 00113016
ϕ 0.542	ϕ 13.8	FSC-16-13.8-C	1335 00113816
ϕ 0.551	ϕ 14.0	FSC-16-14.0-C	1335 00114016
ϕ 0.562	ϕ 14.3	FSC-16-14.3-C	1335 00114316
ϕ 0.590	ϕ 15.0	FSC-22-15.0-C	1335 00115022
ϕ 0.629	ϕ 16.0	FSC-22-16.0-C	1335 00116022
ϕ 0.652	ϕ 16.6	FSC-22-16.6-C	1335 00116622
ϕ 0.669	ϕ 17.0	FSC-22-17.0-C	1335 00117022
ϕ 0.697	ϕ 17.8	FSC-22-17.8-C	1335 00117822
ϕ 0.700	ϕ 17.8	FSC-22-17.8-C	1335 00117822
ϕ 0.708	ϕ 18.0	FSC-22-18.0-C	1335 00118022
ϕ 0.748	ϕ 19.0	FSC-22-19.0-C	1335 00119022
ϕ 0.800	ϕ 20.4	FSC-22-20.4-C	1335 00120422
ϕ 0.787	ϕ 20.0	FSC-22-20.0-C	1335 00120022
ϕ 0.826	ϕ 21.0	FSC-22-21.0-C	1335 00121022
ϕ 0.866	ϕ 22.0	FSC-22-22.0-C	1335 00122022
ϕ 0.905	ϕ 23.0	FSC-22-23.0-C	1335 00123022

Se deberá elegir el tipo OH en caso de que no se use el refrigerante desde el husillo de la máquina.

OH type shall be selected in case not utilizing coolant through from the machine spindle.

Ejemplo para Ordenar - Ordering Example

FSC - 16 - 9.0 - OH
 Series 16 Dia. del zanco de la herramienta
 16 Series Tool Shank Dia.

Ejemplo para Ordenar - Ordering Example

FSC - 16 - 9.0 - C
 Series 16 Dia. del zanco de la herramienta
 16 Series Tool Shank Dia.

TP1

Quick Change Tapping Chuck

- La compresión fuerte permite el uso con machuelo incorporado.
- Strong compression allows use with rolled thread tap.

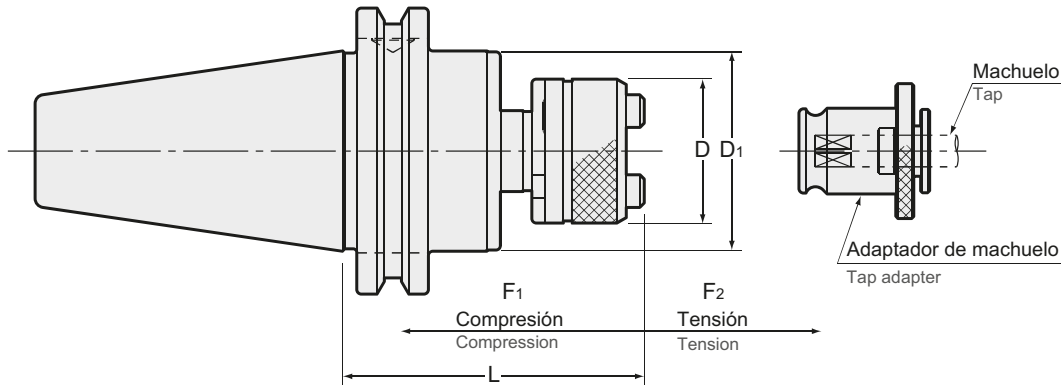

! Para conocer las medidas adecuadas de machuelo, consulte la tabla en la pág.485-486.
For capable tap sizes, please refer to P. 485-486 chart.

Unidad : Pulgadas
Unit : Inch

Código Code	Modelo Model	Medida de machuelo Tap Size	Medida del adaptador Adapter size	D	D1	L	Compensación axial Axial compensation		kg
							F1	F2	
2030 00401062	CAT40 -TP1 -1 -62	#0-12, 1/4-1/2 M3-M12	1	1.260	1.750	2.441	0.236	0.709	1.0
2030 00402093	CAT40 -TP1 -2 -93	5/16-7/8 M8-M22	2	1.969	1.795	3.661	0.591	0.787	1.4
2030 00403179	CAT40 -TP1 -3 -179	13/16-1-3/8 M16-M38	3	2.835	2.441	7.047	0.787	0.787	
2030 00501071	CAT50 -TP1 -1 -71	#0-12, 1/4-1/2 M3-M12	1	1.260	2.750	2.795	0.236	0.709	3.2
2030 00502102	CAT50 -TP1 -2 -102	5/16-7/8 M8-M22	2	1.969	2.750	4.015	0.591	0.787	3.7
2030 00503142	CAT50 -TP1 -3 -142	13/16-1-3/8 M16-M38	3	2.835	2.750	5.708	0.787	0.787	4.5
2030 00504165	CAT50 -TP1 -4 -165	7/8-1-3/4 M22-M48	4	3.740	3.268	6.496	0.886	0.886	6.3

1. Para prevenir que el machuelo se rompa, use el adaptador de machuelo con un dispositivo seguro de torque.
2. El adaptador de machuelo se vende por separado

1. To prevent tap breakage, use tap adapter with safety torque device.
2. Tap adapter is sold separately.



Ejemplo para Ordenar - Ordering Example

CAT50 - TP1-2 - 93

Interfaz y diámetro de husillo Shank size	Medida de adaptador Adapter size	Longitud de proyección Projection length(L)
--	-------------------------------------	--

STP

Synchro Tapping Chuck

- Adaptador de machuelo de cambio rápido
- Para máquinas con ciclos de machuelado rígidos
- Compatible con las boquillas de alta precisión FDC de NT o Bilz (WE/WEN) de cambio rápido.
- Los adaptadores de longitud ajustable ofrecen ajustes rápidos y fáciles.
- Puede usar el refrigerante a través del centro con el uso de las boquillas de refrigerante y alta precisión FDC-OH. (Cuando se usa STC1)
- Quick-changeable tap adapter.
- For machines with rigid tapping cycles.
- Compatible with NT high precision FDC collets or Bilz (WE/WEN) quick change.
- Length adjustable adapters offer quick easy adjustments.
- Coolant-thru capable with the use of FDC-OH high precision coolant collets. (When STC1 is used)

STP

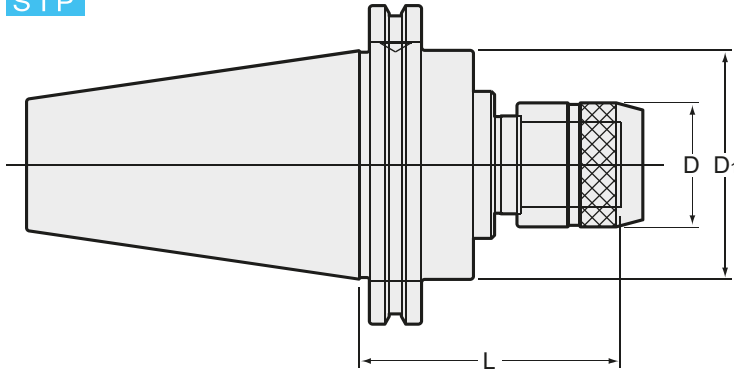

STC

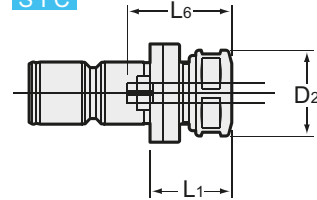

WEN or WE

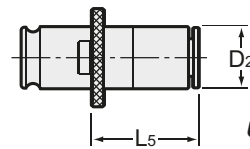

Unidad : Pulgadas
Unit : Inch

Código Code	Modelo Model	L	D	D1	kg	Medida del adaptador Adapter Size	L5	D2	Capacidad de enroscamiento Tapping Capacity	Presión del refrigerante Coolant Pressure
1950 00401075	CAT40 -STP1 -75	2.953	1.496	1.750	1.2	STC1- ***	1.024	1.024	M3 - M12 PT1/8	145psi (1MPa)
1950 00401095	-STP1 -95	3.740	1.496	1.750	1.4	WEN1B- ***	1.299	0.748		
						WE1- ***	0.276	0.748		
1950 00402095	CAT40 -STP2 -95	3.740	2.165	1.850	1.6	STC2- ***	1.378	1.417	M8 - M20 PT1/8,PT1/4,PT3/8	72.5psi (0.5MPa)
1950 00402115	-STP2 -115	4.528	2.165	1.750	1.9	WEN2B- ***	2.323	1.181		
						WE2- ***	0.433	1.181		
1950 00501110	CAT50 -STP1 -110	4.331	1.496	2.750	3.5	STC1- ***	1.024	1.024	M3 - M12 PT1/8	145psi (1MPa)
1950 00502100	CAT50 -STP2 -100	3.937	2.165	2.750	3.6	WEN1B- ***	1.299	0.748		
1950 00502130	-STP2 -130	5.118	2.165	2.750	4.2	WE1- ***	0.276	0.748		
						STC2- ***	1.378	1.417	M8 - M20 PT1/8,PT1/4,PT3/8	72.5psi (0.5MPa)
						WEN2B- ***	2.323	1.181		
						WE2- ***	0.433	1.181		

Unidad : Pulgadas
Unit : Inch

L6			L6		
STC1	MIN	MAX	STC2	MIN	MAX
M3	0.945 (1.063)	1.142	M8	1.339 (1.496)	1.535
M4	1.024 (1.102)	1.220	M10	1.339 (1.496)	1.535
M5	1.220	1.378	M11	1.239 (1.496)	1.496
M6	1.220	1.378	M12	1.378 (1.535)	1.575
M8	1.260	1.457	M14	1.535	1.732
M10	1.260	1.457	M16	1.614	1.811
M11	1.260	1.457	M17	1.614	1.811
M12	1.299	1.457	M18	1.693	1.890
PT1/8	1.339	1.496	M20	1.693	1.890
			PT1/8	1.142	1.299
			PT1/4	1.142	1.220
			PT3/8	1.299	1.339

Modelo Model	Tipo de boquilla - Collet Type		Tuerca ciega Nut	Llave de Torque Spanner
	Métrico, pulgadas Metric, Inch Thread	Machuelo con tubo Pipe Tap		
STC1- * * *	FDC-09	-	HDP-09B KDP-1916	S-1L
	-	ESC10	HDP-16B KDP-2825	S-4L
STC2- * * *	FDC-16	-	HDP-16B KDP-2825	S-4L
	-	ESC16	HDP-16B KDP-2825	S-4L

STP Portaherramienta STP Holder

Ejemplo para Ordenar - Ordering Example

CAT40 - STP1 - 95

Interfaz y diámetro de husillo Shank size Medida del adaptador Adapter size L1

Adaptador de machuelo Tap adapter WE

Pág.480

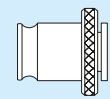

STC Adaptador STC adapter

Ejemplo para Ordenar - Ordering Example

STC1 - M10 - ANSI

Medida Size Medida de machuelo Tap size ANSI,ISO,DIN,JIS

Adaptador de machuelo Tap adapter WEN

Pág.482

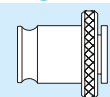

WEN-B BILZ Adaptador de machuelo WEN-B BILZ Tap Adapter

Ejemplo para Ordenar - Ordering Example

WEN1B - M10 - ANSI

Medida Size Medida de machuelo Tap size ANSI,ISO,DIN,JIS

Llave de Torque Spanner

Pág.099



1. El adaptador STC incluye una boquilla y una tuerca. La llave inglesa se vende por separado.
 2. Al ordenar un Adaptador STC, favor de especificar el zanco del machuelo y cuadro de la unidad preajustada.
 3. El STP se puede usar para el refrigerante a través del centro con la boquilla FDC-OH o el C (Pág.087 - 088) y el Adaptador STC.
1. STC adapter includes a collet and nut. Spanner is sold separately.
 2. When ordering STC Adapter, please specify the tap shank and drive square.
 3. With FDC-OH or C collet (p.083-084) and STC Adapter, STP can be used for center-thru coolant.

SLH

Side Lock Holder

● Rango de tolerancia del D.I. h6 - h6 I.D. tolerance

Tipo1
Type1

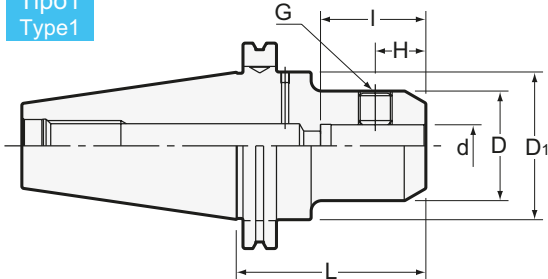

Tipo2
Type2

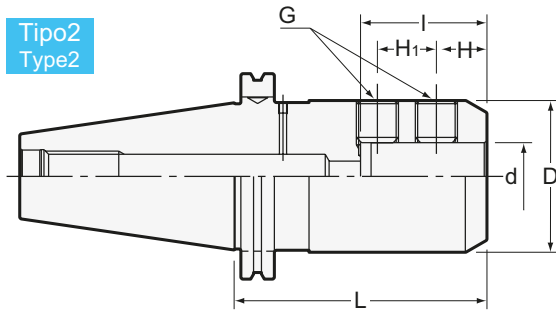

Medida en Pulgadas - Inch Sizes

Unidad : Pulgadas
Unit : Inch

Código Code	Modelo Model	Tipo Type	dH6	D	L	I	H	H1	D1	G	kg
2040 30408065	CAT40 -SLH-0250 -65	1	0.250	0.790	2.559	3.000	0.437	—	1.750	1/4-28 × 1/4	1.1
2040 30408105	-105	1	0.250	0.790	4.134	3.000	0.437	—	1.750	1/4-28 × 1/4	1.1
2040 30410065	CAT40 -SLH-0313 -65	1	0.3125	0.870	2.559	3.000	0.437	—	1.750	5/16-24 × 1/4	1.1
2040 30410105	-105	1	0.3125	0.870	4.134	3.000	0.437	—	1.750	5/16-24 × 1/4	1.1
2040 30412065	CAT40 -SLH-0375 -65	1	0.375	1.000	2.559	3.000	0.710	—	1.750	3/8-24 × 5/16	1.1
2040 30412105	-105	1	0.375	1.000	4.134	3.000	0.710	—	1.750	3/8-24 × 5/16	1.1
2040 30414065	CAT40 -SLH-0438 -65	1	0.4375	1.380	2.559	3.000	0.710	—	1.750	7/16-20 × 3/8	1.2
2040 30414105	-105	1	0.4375	1.380	4.134	3.000	0.710	—	1.750	7/16-20 × 3/8	1.2
2040 30416065	CAT40 -SLH-0500 -65	1	0.500	1.380	2.559	3.000	0.710	—	1.750	7/16-20 × 3/8	1.2
2040 30416105	-105	1	0.500	1.380	4.134	3.000	0.710	—	1.750	7/16-20 × 3/8	1.4
2040 30420065	CAT40 -SLH-0625 -65	1	0.625	1.650	2.559	3.150	0.700	—	1.750	9/16-18 × 1/2	1.2
2040 30420105	-105	1	0.625	1.650	4.134	3.150	0.700	—	1.750	9/16-18 × 1/2	1.6
2040 30424065	CAT40 -SLH-0750 -65	1	0.750	1.750	2.559	3.976	0.740	—	1.750	5/8-18 × 1/2	1.5
2040 30424105	-105	1	0.750	1.750	4.134	3.976	0.740	—	1.750	5/8-18 × 1/2	1.5
2040 30428090	CAT40 -SLH-0875 -90	1	0.875	2.000	3.543	4.331	0.740	—	—	5/8-18 × 1/2	1.5
2040 30428135	-135	1	0.875	2.000	5.315	4.331	0.740	—	—	5/8-18 × 1/2	1.5
2040 30432090	CAT40 -SLH-1000 -90	1	1.000	2.360	3.543	3.543	0.860	—	—	3/4-16 × 11/16	1.8
2040 30432135	-135	1	1.000	2.360	5.315	4.843	0.860	—	—	3/4-16 × 11/16	1.8
2040 30440135	CAT40 -SLH-1250 -135	1	1.250	2.650	5.315	3.543	0.860	—	—	3/4-16 × 11/16	3.6
2040 30440165	-165	1	1.250	2.650	6.496	4.843	0.860	—	—	3/4-16 × 11/16	3.6
2040 30448135	CAT40 -SLH-1500 -135	1	1.500	2.990	5.315	3.543	1.181	—	—	3/4-16 × 11/16	3.6
2040 30448165	-165	1	1.500	2.990	6.496	4.843	1.181	—	—	3/4-16 × 11/16	3.6
2040 30508090	CAT50 -SLH-0250 -90	1	0.250	0.790	3.543	3.000	0.437	—	2.750	1/4-28 × 1/4	3.1
2040 30508135	-135	1	0.250	0.790	5.315	3.000	0.437	—	2.750	1/4-28 × 1/4	3.1
2040 30510090	CAT50 -SLH-0313 -90	1	0.3125	0.870	3.543	3.000	0.437	—	2.750	5/16-24 × 1/4	3.1
2040 30510135	-135	1	0.3125	0.870	5.315	3.000	0.437	—	2.750	5/16-24 × 1/4	3.1
2040 30512090	CAT50 -SLH-0375 -90	1	0.375	1.000	3.543	3.000	0.710	—	2.750	3/8-24 × 5/16	3.3
2040 30512135	-135	1	0.375	1.000	5.315	3.000	0.710	—	2.750	3/8-24 × 5/16	3.3
2040 30514090	CAT50 -SLH-0438 -90	1	0.4375	1.380	3.543	3.000	0.710	—	2.750	7/16-20 × 3/8	3.3
2040 30514135	-135	1	0.4375	1.380	5.315	3.000	0.710	—	2.750	7/16-20 × 3/8	3.3
2040 30516090	CAT50 -SLH-0500 -90	1	0.500	1.380	3.543	3.000	0.710	—	2.750	7/16-20 × 3/8	3.6
2040 30516135	-135	1	0.500	1.380	5.315	3.000	0.710	—	2.750	7/16-20 × 3/8	3.6
2040 30520090	CAT50 -SLH-0625 -90	1	0.625	1.650	3.543	3.150	0.700	—	2.750	9/16-18 × 1/2	3.5
2040 30520135	-135	1	0.625	1.650	5.315	3.150	0.700	—	2.750	9/16-18 × 1/2	3.5
2040 30524090	CAT50 -SLH-0750 -90	1	0.750	1.750	3.543	3.976	0.740	—	2.750	5/8-18 × 1/2	4.0
2040 30524135	-135	1	0.750	1.750	5.315	3.976	0.740	—	2.750	5/8-18 × 1/2	4.0
2040 30528090	CAT50 -SLH-0875 -90	1	0.875	2.000	3.543	4.331	0.740	—	2.750	5/8-18 × 1/2	4.1
2040 30528135	-135	1	0.875	2.000	5.315	4.331	0.740	—	2.750	5/8-18 × 1/2	4.1
2040 30532105	CAT50 -SLH-1000 -105	1	1.000	2.360	4.134	4.843	0.860	—	2.750	3/4-16 × 11/16	5.0
2040 30532150	-150	1	1.000	2.360	5.906	4.843	0.860	—	2.750	3/4-16 × 11/16	5.0
2040 30540105	CAT50 -SLH-1250 -105	1	1.250	2.650	4.134	4.843	0.860	—	2.750	3/4-16 × 11/16	5.4
2040 30540150	-150	1	1.250	2.650	5.906	4.843	0.860	—	2.750	3/4-16 × 11/16	5.4
2040 30548105	CAT50 -SLH-1500 -105	1	1.500	2.990	4.134	4.843	1.181	—	—	3/4-16 × 11/16	4.4
2040 30548150	-150	1	1.500	2.990	5.906	4.843	1.181	—	—	3/4-16 × 11/16	4.4
2040 30564135	CAT50 -SLH-2000 -135	2	2.000	3.740	5.315	4.843	1.260	1.500	—	1-12 × 7/8	6.3
2040 30564165	-165	2	2.000	3.740	6.496	4.843	1.260	1.500	—	1-12 × 7/8	6.3

Ejemplo para Ordenar - Ordering Example

CAT40 - SLH - 0250 - 65

Interfaz y diámetro de husillo
Shank size

Diámetro Interno
I.D. (d)

Longitud de proyección
Projection length (L)

SL2

Side Lock Holder

- Para acabado en fresa JIS con zanco recto y llave.
- For JIS straight shank endmill with flat.



Tipo1
Type1

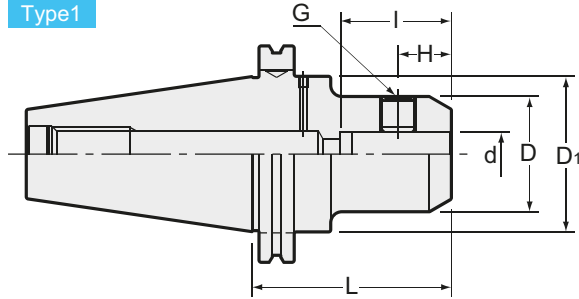

Tipo2
Type2

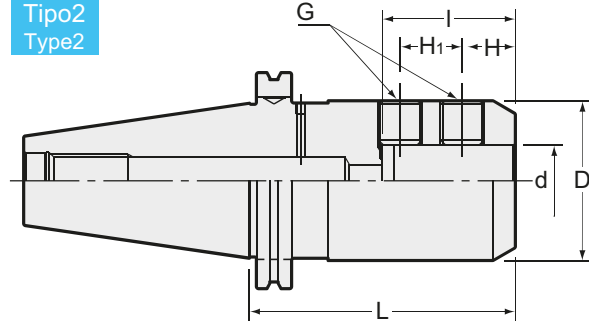

Medidas Métricas - Metric Sizes

Unidad : Pulgadas
Unit : Inch

Código Code	Modelo Model	Tipo Type	dH6 (mm)	D	D1	L	H	H1	I	G (mm)	kg
2040 20406075	CAT40 SL2 -6 -75	1	6	0.984	1.750	2.953	0.709	—	1.417	M 6	1.1
2040 20408075	CAT40 SL2 -8 -75	1	8	1.102	1.750	2.953	0.709	—	1.417	M 8	1.2
2040 20410075	CAT40 SL2 -10 -75	1	10	1.378	1.750	2.953	0.787	—	1.575	M10	1.3
2040 20412075	CAT40 SL2 -12 -75	1	12	1.654	1.750	2.953	0.886	—	1.772	M12	1.4
2040 20416075	CAT40 SL2 -16 -75	1	16	1.890	1.750	2.953	0.945	—	1.890	M14	1.5
2040 20420075	CAT40 SL2 -20 -75	1	20	2.047	1.750	2.953	0.984	—	1.969	M16	1.5
2040 20425090	CAT40 SL2 -25 -90	2	25	2.559	—	3.543	0.945	0.984	2.205	M18	2.1
2040 20432120	CAT40 SL2 -32 -120	2	32	2.835	—	4.724	0.945	1.102	2.362	M20	3.2
2040 20506090	CAT50 SL2 -6 -90	1	6	0.984	2.750	3.543	0.709	—	1.417	M 6	
2040 20508090	CAT50 SL2 -8 -90	1	8	1.102	2.750	3.543	0.709	—	1.417	M 8	
2040 20510090	CAT50 SL2 -10 -90	1	10	1.378	2.750	3.543	0.787	—	1.575	M10	
2040 20512090	CAT50 SL2 -12 -90	1	12	1.654	2.750	3.543	0.886	—	1.772	M12	
2040 20516090	CAT50 SL2 -16 -90	1	16	1.890	2.750	3.543	0.945	—	1.890	M14	
2040 20520090	CAT50 SL2 -20 -90	1	20	2.047	2.750	3.543	0.984	—	1.969	M16	3.7
2040 20525105	CAT50 SL2 -25 -105	2	25	2.559	—	4.134	0.945	0.984	2.205	M18	4.4
2040 20532120	CAT50 SL2 -32 -120	2	32	2.835	—	4.724	0.945	1.102	2.362	M20	5.1
2040 20540120	CAT50 SL2 -40 -120	2	40	3.150	—	4.724	1.181	1.260	2.756	M20	5.4
2040 20542120	CAT50 SL2 -42 -120	2	42	3.228	—	4.724	1.181	1.260	2.756	M20	5.5

Favor de contactar a NT si la herramienta de corte se ha inclinado hasta quedar plana sobre el zanco. El portaherramienta de la herramienta especial que va con esa inclinación puede fabricarse. Special tool holder that matches to the tilted flat can be manufactured.

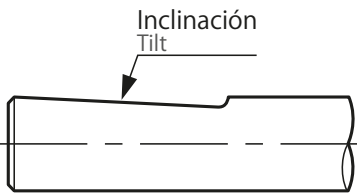

Ejemplo para Ordenar - Ordering Example

CAT40 - SL2 - 6 - 75

Interfaz y diámetro de husillo
Shank size

Diámetro Interno
I.D. (d)

Longitud de proyección
Projection length (L)

Face Mill Arbor

- Para fresa JIS B4113.
- For JIS B4113 face mill.

Tipo1
Type1

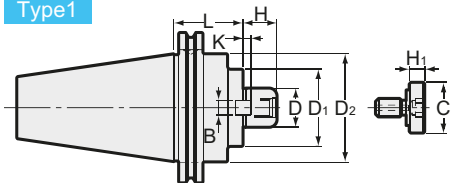

Tipo3
Type3

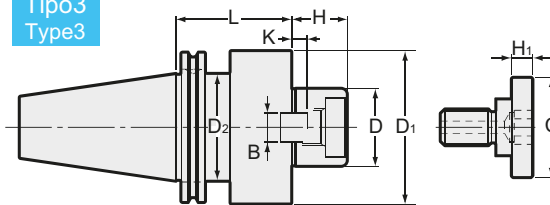

Tipo2
Type2

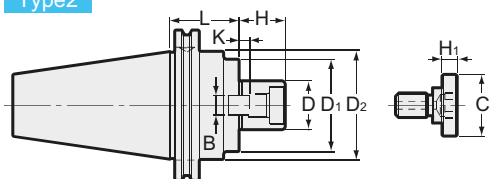

Tipo4
Type4

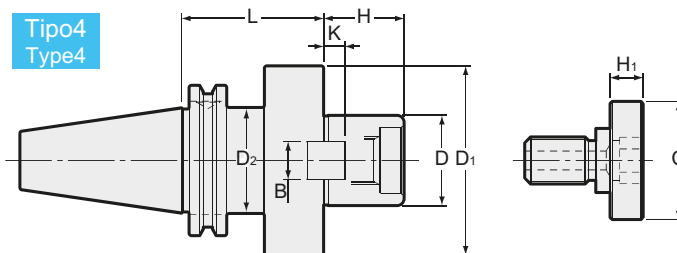

Unidad : Pulgadas
Unit : Inch

Código Code	Modelo Model	Tipo Type	Dh6	L	D1	D2	H	B	K	C	H1	kg	Perno Bolt
2050 00419045	CAT40 -FMA19.05A -45	1	0.750	1.772	1.772	1.750	0.630	0.315	0.138	0.874	0.354	1.3	MBA-M10
2050 00419060	-60	1	0.750	2.362	1.772	1.750	0.630	0.315	0.138	0.874	0.354	1.5	MBA-M10
2050 00419090	-90	1	0.750	3.543	1.772	1.750	0.630	0.315	0.138	0.874	0.354	1.8	MBA-M10
2050 00425045	CAT40 -FMA25.4A -45	3	1.000	1.772	1.969	1.750	0.866	0.374	0.197	1.299	0.394	1.4	MBA-M12
2050 00425090	-90	3	1.000	3.543	1.969	1.750	0.866	0.374	0.197	1.299	0.394	2.1	MBA-M12
2050 00431060	CAT40 -FMA31.75A -60	3	1.250	2.362	2.362	1.750	1.181	0.500	0.276	1.575	0.394	1.8	MBA-M16
2050 00431075	-75	3	1.250	2.953	2.362	1.750	1.181	0.500	0.276	1.575	0.394	2.1	MBA-M16
2050 00438060	CAT40 -FMA38.1A -60	4	1.500	2.362	3.150	1.750	1.339	0.626	0.354	1.969	0.551	2.5	MBA-M20
2050 00438090	-90	4	1.500	3.543	3.150	1.750	1.339	0.626	0.354	1.969	0.551	3.4	MBA-M20
2050 00525045	CAT50 -FMA25.4A -45	1	1.000	1.772	1.969	2.750	0.866	0.374	0.197	1.299	0.394	3.5	MBA-M12
2050 00525090	-90	1	1.000	3.543	1.969	2.750	0.866	0.374	0.197	1.299	0.394	4.2	MBA-M12
2050 00525150	-150	1	1.000	5.906	1.969	2.750	0.866	0.374	0.197	1.299	0.394	5.1	MBA-M12
2050 00531045	CAT50 -FMA31.75A -45	2	1.250	1.772	2.362	2.750	1.181	0.500	0.276	1.575	0.394	3.6	MBA-M16
2050 00531075	-75	2	1.250	2.953	2.362	2.750	1.181	0.500	0.276	1.575	0.394		MBA-M16
2050 00531105	-105	2	1.250	4.134	2.362	2.750	1.181	0.500	0.276	1.575	0.394		MBA-M16
2050 00538045	CAT50 -FMA38.1A -45	2	1.500	1.772	3.150	2.750	1.339	0.626	0.354	1.969	0.551	4.0	MBA-M20
2050 00538075	-75	2	1.500	2.953	3.150	2.750	1.339	0.626	0.354	1.969	0.551	5.2	MBA-M20

Incluye el perno de sujeción.
Clamp bolt is Included.

Ejemplo para Ordenar - Ordering Example

CAT40 - FMA 19.05A - 45

Interfaz y diámetro
de husillo
Shank size

Diámetro 1
D1

Longitud de
proyección
Projection
length (L)

Side Cutter Arbor

- Para cortador lateral JIS y sierra metálica.
- For JIS side cutter and metal saw.

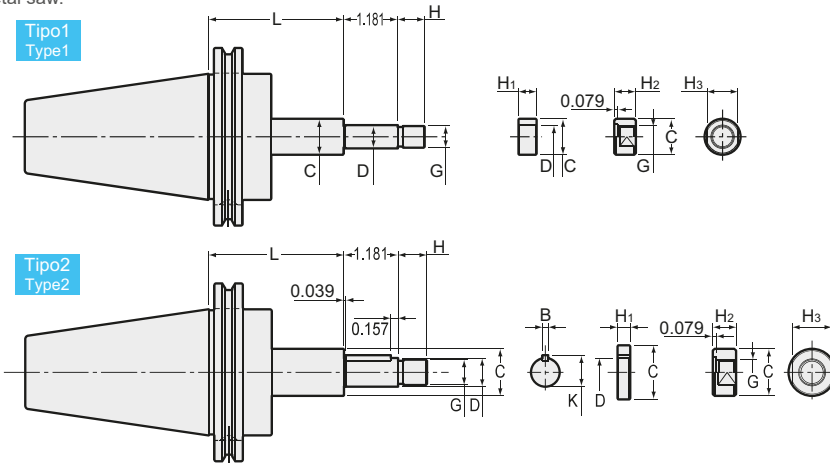

Medida en Pulgadas - Inch Sizes

Unidad : Pulgadas
Unit : Inch

Código Code	Modelo Model	Tipo Type	D ($\frac{B_{10}}{h_6}$)	L	C	G (mm)	H	B	K	H1	H2	H3
1900 01412060	CAT40 -SCA12.7 -60	1	0.500	2.362	0.787	M12 × 1.25	0.591	—	—	0.118, 0.197, 0.276, 0.315, 0.394, 0.472	0.472	0.669 (17mm)
1900 01412090	-90	1	0.500	3.543	0.787	M12 × 1.25	0.591	—	—	0.118, 0.197, 0.276, 0.315, 0.394, 0.472	0.472	0.669 (17mm)
1900 01415075	CAT40 -SCA15.875 -75	2	0.625	2.953	1.024	M14 × 1.5	0.630	0.125	0.686	0.118, 0.197, 0.276, 0.315, 0.394, 0.472	0.512	0.866 (22mm)
1900 01415105	-105	2	0.625	4.134	1.024	M14 × 1.5	0.630	0.125	0.686	0.118, 0.197, 0.276, 0.315, 0.394, 0.472	0.512	0.866 (22mm)
1900 01422075	CAT40 -SCA22.225 -75	2	0.875	2.953	1.339	M20 × 1.5	0.827	0.125	0.938	0.118, 0.197, 0.276, 0.315, 0.394, 0.472	0.709	1.181 (30mm)
1900 01422105	-120	2	0.875	4.724	1.339	M20 × 1.5	0.827	0.125	0.938	0.118, 0.197, 0.276, 0.315, 0.394, 0.472	0.709	1.181 (30mm)
1900 01425075	CAT40 -SCA25.4 -75	2	1.000	2.953	1.575	M24 × 2	0.984	0.250	1.094	0.118, 0.197, 0.276, 0.315, 0.394, 0.472	0.827	1.260 (32mm)
1900 01425120	-120	2	1.000	4.724	1.575	M24 × 2	0.984	0.250	1.094	0.118, 0.197, 0.276, 0.315, 0.394, 0.472	0.827	1.260 (32mm)
1900 01431090	CAT40 -SCA31.75 -90	2	1.250	3.543	1.811	M30 × 2	1.181	0.312	1.375	0.118, 0.197, 0.276, 0.315, 0.394, 0.472	1.024	1.614 (41mm)
1900 01512075	CAT50 -SCA12.7 -75	1	0.500	2.953	0.787	M12 × 1.25	0.591	—	—	0.118, 0.197, 0.276, 0.315, 0.394, 0.472	0.472	0.669 (17mm)
1900 01512105	-105	1	0.500	4.134	0.787	M12 × 1.25	0.591	—	—	0.118, 0.197, 0.276, 0.315, 0.394, 0.472	0.472	0.669 (17mm)
1900 01515090	CAT50 -SCA15.875 -90	2	0.625	3.543	1.024	M14 × 1.5	0.630	0.125	0.686	0.118, 0.197, 0.276, 0.315, 0.394, 0.472	0.512	0.866 (22mm)
1900 01515120	-120	2	0.625	4.724	1.024	M14 × 1.5	0.630	0.125	0.686	0.118, 0.197, 0.276, 0.315, 0.394, 0.472	0.512	0.866 (22mm)
1900 01522090	CAT50 -SCA22.225 -90	2	0.875	3.543	1.339	M20 × 1.5	0.827	0.125	0.938	0.118, 0.197, 0.276, 0.315, 0.394, 0.472	0.709	1.181 (30mm)
1900 01522135	-135	2	0.875	5.315	1.339	M20 × 1.5	0.827	0.125	0.938	0.118, 0.197, 0.276, 0.315, 0.394, 0.472	0.709	1.181 (30mm)
1900 01525090	CAT50 -SCA25.4 -90	2	1.000	3.543	1.575	M24 × 2	0.984	0.250	1.094	0.118, 0.197, 0.276, 0.315, 0.394, 0.472	0.827	1.260 (32mm)
1900 01525135	-135	2	1.000	5.315	1.575	M24 × 2	0.984	0.250	1.094	0.118, 0.197, 0.276, 0.315, 0.394, 0.472	0.827	1.260 (32mm)
1900 01531090	CAT50 -SCA31.75 -90	2	1.250	3.543	1.811	M30 × 2	1.181	0.312	1.375	0.118, 0.197, 0.276, 0.315, 0.394, 0.472	1.024	1.614 (41mm)
1900 01531135	-135	2	1.250	5.314	1.811	M30 × 2	1.181	0.312	1.375	0.118, 0.197, 0.276, 0.315, 0.394, 0.472	1.024	1.614 (41mm)
1900 01538090	CAT50 -SCA38.1 -90	2	1.500	3.543	2.165	M36 × 3	1.417	0.375	1.656	0.118, 0.197, 0.276, 0.315, 0.394, 0.472	1.220	1.811 (46mm)
1900 01538135	-135	2	1.500	5.315	2.165	M36 × 3	1.417	0.375	1.656	0.118, 0.197, 0.276, 0.315, 0.394, 0.472	1.220	1.811 (46mm)

Incluye una tuerca de sujeción y espaciadores (en medida 3, 5, 7, 8, 10 y 12/ uno de cada uno).
One clamp nut and spacers (size 3, 5, 7, 8, 10, and 12 / one each) are included.

Ejemplo para Ordenar - Ordering Example

CAT40 - SCA 12.7 - 60Interfaz y diámetro de husillo
Shank sizeDiámetro 1
D1Longitud de proyección
Projection length (L)

Medidas Métricas - Metric Sizes

Unidad : Pulgadas
Unit : Inch

Código Code	Modelo Model	Tipo Type	D (B10 h 6)	L	C	G (mm)	H	B	K	H1	H2	H3
01900000413060	CAT40 -SCA13 -60	1	13	2.362	0.787	M12 × 1.25	0.591	—	—	0.118, 0.197, 0.276, 0.315, 0.394, 0.472	0.472	0.669 (17mm)
01900000413090	-90	1	13	3.543	0.787	M12 × 1.25	0.591	—	—	0.118, 0.197, 0.276, 0.315, 0.394, 0.472	0.472	0.669 (17mm)
01900000416075	CAT40 -SCA16 -75	2	16	2.953	1.024	M14 × 1.5	0.630	0.157	0.677	0.118, 0.197, 0.276, 0.315, 0.394, 0.472	0.512	0.866 (22mm)
01900000416105	-105	2	16	4.134	1.024	M14 × 1.5	0.630	0.157	0.677	0.118, 0.197, 0.276, 0.315, 0.394, 0.472	0.512	0.866 (22mm)
01900000422075	CAT40 -SCA22 -75	2	22	2.953	1.339	M20 × 1.5	0.827	0.236	0.929	0.118, 0.197, 0.276, 0.315, 0.394, 0.472	0.709	1.181 (30mm)
01900000422120	-120	2	22	4.724	1.339	M20 × 1.5	0.827	0.236	0.929	0.118, 0.197, 0.276, 0.315, 0.394, 0.472	0.709	1.181 (30mm)
01900000427075	CAT40 -SCA27 -75	2	27	2.953	1.575	M24 × 2	0.984	0.276	1.142	0.118, 0.197, 0.276, 0.315, 0.394, 0.472	0.827	1.260 (32mm)
01900000427120	-120	2	27	4.724	1.575	M24 × 2	0.984	0.276	1.142	0.118, 0.197, 0.276, 0.315, 0.394, 0.472	0.827	1.260 (32mm)
01900000432090	CAT40 -SCA32 -90	2	32	3.543	1.811	M30 × 2	1.181	0.315	1.339	0.118, 0.197, 0.276, 0.315, 0.394, 0.472	1.024	1.614 (41mm)
01900000513075	CAT50 -SCA13 -75	1	13	2.953	0.787	M12 × 1.25	0.591	—	—	0.118, 0.197, 0.276, 0.315, 0.394, 0.472	0.472	0.669 (17mm)
01900000513105	-105	1	13	4.134	0.787	M12 × 1.25	0.591	—	—	0.118, 0.197, 0.276, 0.315, 0.394, 0.472	0.472	0.669 (17mm)
01900000516090	CAT50 -SCA16 -90	2	16	3.543	1.024	M14 × 1.5	0.630	0.157	0.677	0.118, 0.197, 0.276, 0.315, 0.394, 0.472	0.512	0.866 (22mm)
01900000516120	-120	2	16	4.724	1.024	M14 × 1.5	0.630	0.157	0.677	0.118, 0.197, 0.276, 0.315, 0.394, 0.472	0.512	0.866 (22mm)
01900000522090	CAT50 -SCA22 -90	2	22	3.543	1.339	M20 × 1.5	0.827	0.236	0.929	0.118, 0.197, 0.276, 0.315, 0.394, 0.472	0.709	1.181 (30mm)
01900000522135	-135	2	22	5.315	1.339	M20 × 1.5	0.827	0.236	0.929	0.118, 0.197, 0.276, 0.315, 0.394, 0.472	0.709	1.181 (30mm)
01900000527090	CAT50 -SCA27 -90	2	27	3.543	1.575	M24 × 2	0.984	0.276	1.142	0.118, 0.197, 0.276, 0.315, 0.394, 0.472	0.827	1.260 (32mm)
01900000527135	-135	2	27	5.315	1.575	M24 × 2	0.984	0.276	1.142	0.118, 0.197, 0.276, 0.315, 0.394, 0.472	0.827	1.260 (32mm)
01900000532090	CAT50 -SCA32 -90	2	32	3.543	1.811	M30 × 2	1.181	0.315	1.339	0.118, 0.197, 0.276, 0.315, 0.394, 0.472	1.024	1.614 (41mm)
01900000532135	-135	2	32	5.314	1.811	M30 × 2	1.181	0.315	1.339	0.118, 0.197, 0.276, 0.315, 0.394, 0.472	1.024	1.614 (41mm)
01900000540090	CAT50 -SCA40 -90	2	40	3.543	2.165	M36 × 3	1.417	0.394	1.673	0.118, 0.197, 0.276, 0.315, 0.394, 0.472	1.220	1.811 (46mm)
01900000540135	-135	2	40	5.315	2.165	M36 × 3	1.417	0.394	1.673	0.118, 0.197, 0.276, 0.315, 0.394, 0.472	1.220	1.811 (46mm)

Incluye una tuerca de sujeción y espaciadores (en medida 3, 5, 7, 8, 10 y 12/ uno de cada uno).
One clamp nut and spacers (size 3, 5, 7, 8, 10, and 12 / one each) are included.

Ejemplo para Ordenar - Ordering Example

CAT40 - SCA 13 - 60		
Interfaz y diámetro de husillo Shank size	Diámetro 1 D1	Longitud de proyección Projection length (L)



Jacobs Taper Arbor

- Portaherramienta para el machuelo sin llaves ahusado Jacobs
- Arbor for Jacobs taper keyless chuck.

Tipo1
Type1

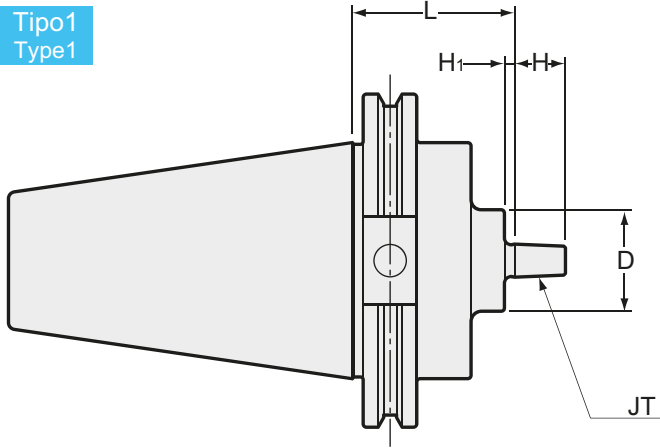

Tipo2
Type2

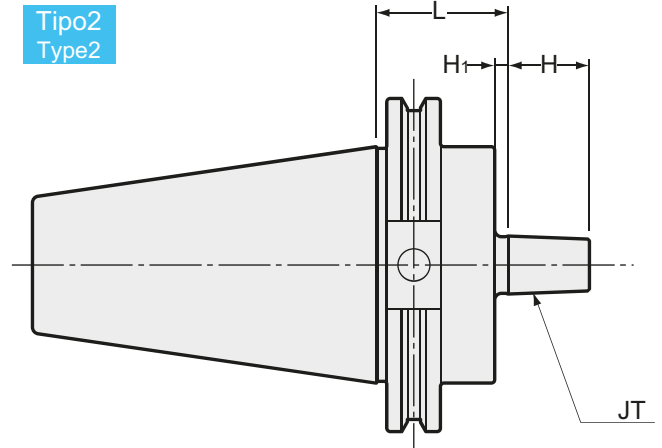

Unidad : Pulgadas
Unit : Inch

Código Code	Modelo Model	Tipo Type	Medida JT Size JT	L	D	H	H1
1920 00402045	CAT40 -JTA 2 -45	1	2	1.772	1.181	0.787	0.157
1920 00433045	CAT40 -JTA33 -45	1	33	1.772	1.181	0.945	0.157
1920 00406045	CAT40 -JTA 6 -45	1	6	1.772	1.181	0.945	0.157
1920 00403045	CAT40 -JTA 3 -45	1	3	1.772	1.378	1.102	0.197
1920 00502045	CAT50 -JTA 2 -45	1	2	1.772	1.181	0.787	0.157
1920 00533045	CAT50 -JTA33 -45	1	33	1.772	1.181	0.945	0.157
1920 00506045	CAT50 -JTA 6 -45	1	6	1.772	1.181	0.945	0.157
1920 00503045	CAT50 -JTA 3 -45	2	3	1.772	—	1.102	0.276

Ejemplo para Ordenar - Ordering Example

CAT40 - JTA2 - 45

Interfaz y diámetro
de husillo

Medida JT

Longitud de
proyección

Shank size

Size JT

Projection
length (L)

BT
CAT
AHO
HSK-A/E/F/C
HSK-T
C
UTS
Máquinas
Especializadas
Specialized
Machine
Equipo
Relacionado
Related
Equipment
Taladro de
Biselado & de
Casquillo
Bush &
Chamfering
Drill

Milling Chuck

Collet Holder

"R" Zero Holder

Hydraulic
Chuck

Shrink Fit

Tapping Chuck

Arbors

Function
Holder

Retention Stud

Tool Shank
Dimensions

Morse Taper Holder

- Para el portaherramienta de zanco Morse con espiga
- For Morse taper shank with tang.

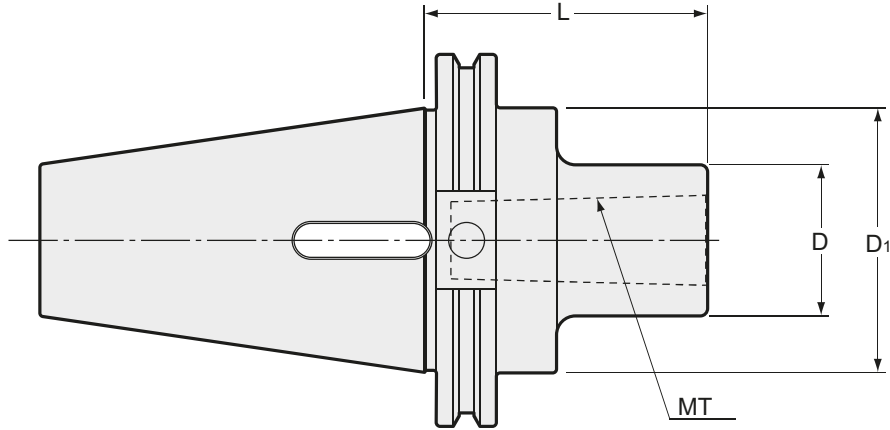

Unidad : Pulgadas
Unit : Inch

Código Code	Modelo Model	Medida MT Size MT	L	D	D1	kg
1930 00401045	CAT40 MTA1 -45	1	1.770	1.000	1.750	
1930 00402060	CAT40 MTA2 -60	2	2.360	1.260	1.750	
1930 00403075	CAT40 MTA3 -75	3	3.000	1.570	1.750	
1930 00404090	CAT40 MTA4 -90	4	3.540	1.970	1.750	
1930 00502060	CAT50 MTA2 -60	2	2.360	1.260	2.750	3.1
1930 00503075	CAT50 MTA3 -75	3	3.000	1.570	2.750	3.2
1930 00504090	CAT50 MTA4 -90	4	3.540	1.970	2.750	3.3
1930 00505105	CAT50 MTA5 -105	5	4.130	2.760	2.750	

Ejemplo para Ordenar - Ordering Example

CAT40	-	MTA1	-	45
Interfaz y diámetro de husillo		Medida MT		Longitud de proyección
Shank size		size MT		Projection length (L)

Keyless Drill Chuck

- El diseño integral del zanco permite el uso de una llave inglesa, lo que proporciona hasta 4 veces más fuerza de agarre que un portaherramienta de zanco Jacobs tradicional.
- El diseño integral del zanco quita la separación del portaherramienta y de la broca del cortador.
- La fuerza de agarre aumentada reduce la ruptura por perforar después de penetrar el material.
- El diseño integral del zanco proporciona una mayor precisión.
- Integral shank design allows the use of a spanner wrench providing up to 4 times more gripping force than conventional Jacobs taper drill chucks.
- Integral shank design eliminates separation of the chuck from the arbor.
- Increased gripping force minimizes drill breakage after material penetration.
- Integral shank design provides improved accuracy.

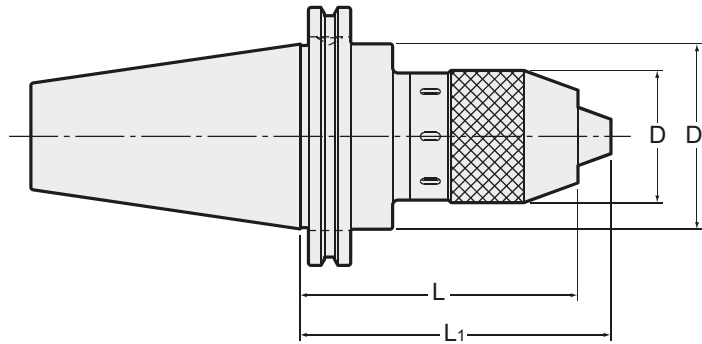

Unidad : Pulgadas
Unit : Inch

Código Code	Modelo Model	Diá. de Sujeción Chucking Dia.	D	D1	L	L1	kg	Llave Inglesa Spanner
2060 00413105	CAT40 -KLD13 -105	0.020 - 0.512	1.969	1.750	4.134	4.606	1.8	FC13LC
2060 00465105	-KLD6.5 -105	0.020 - 0.256	1.339	1.750	4.134	4.606	1.4	FC6.5LC
2060 00565105	CAT50 -KLD6.5 -105	0.020 - 0.256	1.339	2.750	4.134	4.606		FC6.5LC
2060 00513105	-KLD13 -105	0.020 - 0.512	1.969	2.750	4.134	4.606	3.9	FC13LC
2060 00513165	-KLD13 -135	0.020 - 0.512	1.969	2.750	5.315	5.787		FC13LC

Llave Inglesa (Opcional)
Spanner (optional)

Modelo Model	Código Code
FC6.5LC	2685 0000065
FC13LC	2685 0000130

Ejemplo para Ordenar - Ordering Example

CAT40 - KLD13 - 105

Interfaz y diámetro de husillo

Shank size

Diá. Máximo de sujeción

Max. chucking dia.

Longitud de proyección

Projection length (L)

BT

CAT

AHO

HSK-A/E/F/C

HSK-T

C

UTS

Máquinas Especializadas
Specialized Machine

Equipo Relacionado
Related Equipment

Taladro de Biselado & de Casquillo
Bush & Chamfering Drill

Milling Chuck
Collet Holder

"R" Zero Holder
Hydraulic Chuck

Shrink Fit
Tapping Chuck

Arbors
Function Holder

Retention Stud
Tool Shank Dimensions

Arbors

Function Holder

Retention Stud

Tool Shank Dimensions

Tool Shank Dimensions

HP-H

High-speed type

30,000min⁻¹

CAT

Hyper Spindle (Speed Inzeaser)

- Habilita la operación de corte a alta velocidad al multiplicar la velocidad del husillo de la máquina en el borde de corte. (Máx 30000 mín⁻¹)
- Enables high speed cutting operation by multiplying the machine spindle speed at the cutting edge. (Max30000min⁻¹)

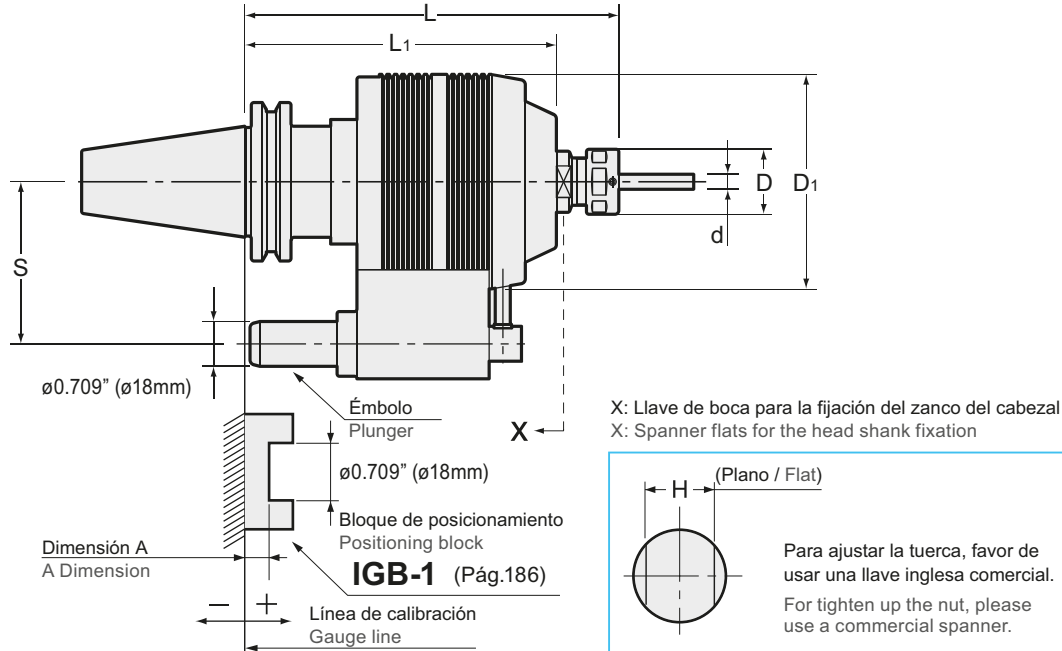

Unidad : Pulgadas
Unit : Inch

Código Code	Modelo Model	d	L	L1	D	D1	S	H	Desmultiplicación Gear ratio	MAX rpm	kg	Tuerca Nut
2070 1 ※ 407150	CAT40 -HP07H -150 -※	0.020 - 0.276	5.906	4.921	0.906	3.386	2.559 (65mm)	0.630 (16mm)	5:1	30,000	3.3	HDP-07A
2070 1 ※ 407180	-180 -※	0.020 - 0.276	7.087	4.921	0.906	3.386	2.559 (65mm)	0.630 (16mm)	5:1	30,000		HDP-07A
2070 1 ※ 409150	CAT40 -HP09H -150 -※	0.098 - 0.354	5.906	4.921	1.024	3.386	2.559 (65mm)	0.827 (21mm)	5:1	30,000		HDP-09
2070 1 ※ 409180	-180 -※	0.098 - 0.354	7.087	4.921	1.024	3.386	2.559 (65mm)	0.827 (21mm)	5:1	30,000		HDP-09
2070 1 ※ 412165	CAT40 -HP12H -165 -※	0.098 - 0.472	6.496	4.921	1.260	3.386	2.559 (65mm)	0.827 (21mm)	5:1	30,000		HDP-12
2070 1 ※ 412180	-180 -※	0.098 - 0.472	7.087	4.921	1.260	3.386	2.559 (65mm)	0.827 (21mm)	5:1	30,000		HDP-12
2070 1 ※ 507150	CAT50 -HP07H -150 -※	0.020 - 0.276	5.906	4.921	0.906	3.386	3.150 (80mm)	0.630 (16mm)	5:1	30,000		HDP-07A
2070 1 ※ 507180	-180 -※	0.020 - 0.276	7.087	4.921	0.906	3.386	3.150 (80mm)	0.630 (16mm)	5:1	30,000		HDP-07A
2070 1 ※ 509150	CAT50 -HP09H -150 -※	0.098 - 0.354	5.906	4.921	1.024	3.386	3.150 (80mm)	0.827 (21mm)	5:1	30,000		HDP-09
2070 1 ※ 509180	-180 -※	0.098 - 0.354	7.087	4.921	1.024	3.386	3.150 (80mm)	0.827 (21mm)	5:1	30,000		HDP-09
2070 1 ※ 512165	CAT50 -HP12H -165 -※	0.098 - 0.472	6.496	4.921	1.260	3.386	3.150 (80mm)	0.827 (21mm)	5:1	30,000		HDP-12
2070 1 ※ 512180	-180 -※	0.098 - 0.472	7.087	4.921	1.260	3.386	3.150 (80mm)	0.827 (21mm)	5:1	30,000		HDP-12

Boquilla Collet	Llave Inglesa Spanner	Tabla del émbolo - Plunger No.					
		No.1	No.2	No.3	No.4	No.5	
Pág.090-093	Pág.099	All Type	+0.594 ~ +0.945	+0.240 ~ +0.591	-0.114 ~ +0.236	-0.469 ~ -0.118	-0.823 ~ -0.472

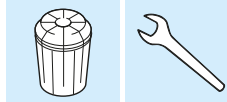

1. Al hacer su orden, favor de especificar el número de émbolo (No. 1~No.5).
 2. El émbolo es ajustable. Favor de dirigirse a la tabla superior.
 3. La boquilla y la llave inglesa se venden por separado.
 4. Sólo use una boquilla de categoría AA.
1. When ordering, please specify the plunger number (No.1~No.5).
 2. Plunger is adjustable. Please refer to a chart up.
 3. Collet and spanner are sold separately.
 4. Use AA class collet only.

Ejemplo para Ordenar - Ordering Example

CAT40 - HP 07 H - 150 - 1

Interfaz y diámetro de husillo	Máx. Diámetro Interno de boquilla	Longitud de proyección	No. de émbolo
Shank size	Max. collet I.D.	Projection length (L)	Plunger No.

BT

CAT

AHO

HSK-A/E/F/C

HSK-T

C

UTS

Máquinas Especializadas

Specialized Machine

Equipo Relacionado

Related Equipment

Taladro de Biselado & de Casquillo

Bush & Chamfering Drill

Angle Heads (ER Collet Type)

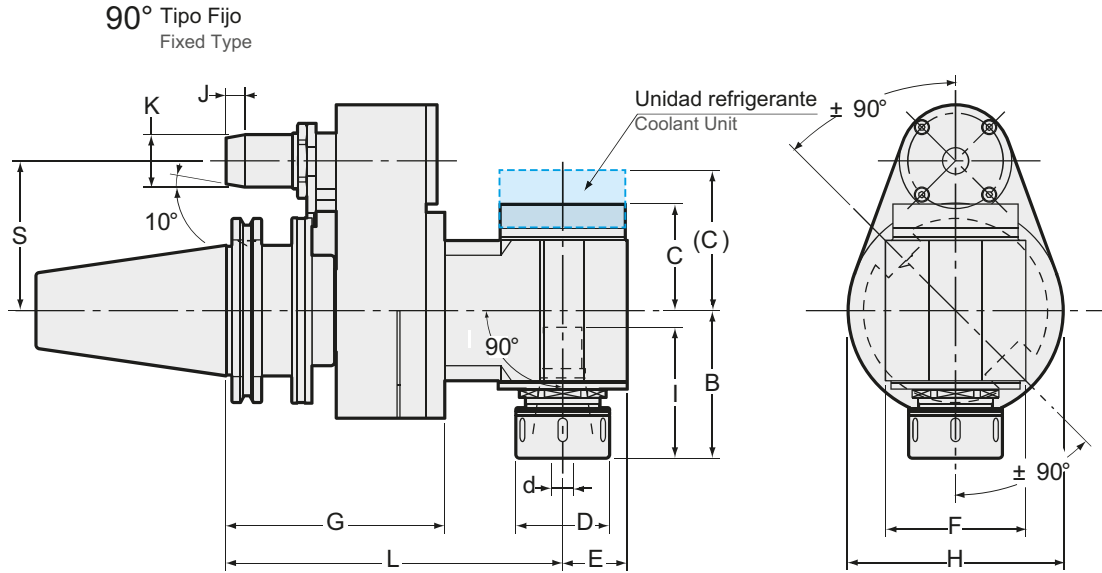

※ Necesita de un bloque de posicionamiento. Favor de consultar de la pág.185-186.
 ※ Requires a positioning block. Please refer to P.185-186.

Unidad : Pulgadas
 Unit : Inch

Código Code	Modelo Model	d	L	G	E	D	F	H	C (C)	B	I	J	K	S
2090 241166 ※※	CAT40 -AHE1190 -165 -65- ※※	0.020 -0.276	6.496	4.646	0.669	0.906	2.008	3.543	1.299 (1.830)	1.693	1.575	0.315	0.772 (19.6mm)	2.559 (65mm)
2090 241196 ※※	-195 -65- ※※	0.020 -0.276	7.677	4.646	0.669	0.906	2.008	3.543	1.299 (1.830)	1.693	1.575	0.315	0.772 (19.6mm)	2.559 (65mm)
2090 241126 ※※	-225 -65- ※※	0.020 -0.276	8.858	4.646	0.669	0.906	2.008	3.543	1.299 (1.830)	1.693	1.575	0.315	0.772 (19.6mm)	2.559 (65mm)
2090 241156 ※※	-255 -65- ※※	0.020 -0.276	10.039	5.315	0.669	0.906	2.008	3.543	1.299 (1.830)	1.693	1.575	0.315	0.772 (19.6mm)	2.559 (65mm)
2090 241186 ※※	-285 -65- ※※	0.020 -0.276	11.220	5.315	0.669	0.906	2.008	3.543	1.299 (1.830)	1.693	1.575	0.315	0.772 (19.6mm)	2.559 (65mm)
2090 241666 ※※	CAT40 -AHE1690 -165 -65- ※※	0.020 -0.394	6.496	4.646	0.866	1.260	2.283	3.543	1.752 (2.303)	2.441	2.559	0.315	0.772 (19.6mm)	2.559 (65mm)
2090 241696 ※※	-195 -65- ※※	0.020 -0.394	7.677	4.646	0.866	1.260	2.283	3.543	1.752 (2.303)	2.441	2.559	0.315	0.772 (19.6mm)	2.559 (65mm)
2090 241626 ※※	-225 -65- ※※	0.020 -0.394	8.858	4.646	0.866	1.260	2.283	3.543	1.752 (2.303)	2.441	2.559	0.315	0.772 (19.6mm)	2.559 (65mm)
2090 241656 ※※	-255 -65- ※※	0.020 -0.394	10.039	5.315	0.866	1.260	2.283	3.543	1.752 (2.303)	2.441	2.559	0.315	0.772 (19.6mm)	2.559 (65mm)
2090 242066 ※※	CAT40 -AHE2090 -165 -65- ※※	0.020 -0.512	6.496	4.646	1.102	1.378	2.638	3.543	2.008 (2.539)	2.717	2.717	0.315	0.772 (19.6mm)	2.559 (65mm)
2090 242096 ※※	-195 -65- ※※	0.020 -0.512	7.677	4.646	1.102	1.378	2.638	3.543	2.008 (2.539)	2.717	2.717	0.315	0.772 (19.6mm)	2.559 (65mm)
2090 242026 ※※	-225 -65- ※※	0.020 -0.512	8.858	4.646	1.102	1.378	2.638	3.543	2.008 (2.539)	2.717	2.717	0.315	0.772 (19.6mm)	2.559 (65mm)
2090 242566 ※※	CAT40 -AHE2590 -165 -65- ※※	0.020 -0.630	6.496	4.646	1.102	1.654	2.638	3.543	2.008 (2.539)	2.717	2.717	0.315	0.772 (19.6mm)	2.559 (65mm)
2090 242596 ※※	-195 -65- ※※	0.020 -0.630	7.677	4.646	1.102	1.654	2.638	3.543	2.008 (2.539)	2.717	2.717	0.315	0.772 (19.6mm)	2.559 (65mm)
2090 242526 ※※	-225 -65- ※※	0.020 -0.630	8.858	4.646	1.102	1.654	2.638	3.543	2.008 (2.539)	2.717	2.717	0.315	0.772 (19.6mm)	2.559 (65mm)

Código Code	Modelo Model	d	L	G	E	D	F	H	C (C)	B	I	J	K	S
2090 251168 ※※	CAT50 -AHE1190 -165 -80- ※※	0.020 -0.276	6.496	4.646	0.669	0.906	2.008	3.543	1.299 (1.830)	1.693	1.575	0.394	1.102 (28mm)	3.150 (80mm)
2090 251198 ※※	-195 -80- ※※	0.020 -0.276	7.677	4.646	0.669	0.906	2.008	3.543	1.299 (1.830)	1.693	1.575	0.394	1.102 (28mm)	3.150 (80mm)
2090 251128 ※※	-225 -80- ※※	0.020 -0.276	8.858	4.646	0.669	0.906	2.008	3.543	1.299 (1.830)	1.693	1.575	0.394	1.102 (28mm)	3.150 (80mm)
2090 251158 ※※	-255 -80- ※※	0.020 -0.276	10.039	5.315	0.669	0.906	2.008	3.543	1.299 (1.830)	1.693	1.575	0.394	1.102 (28mm)	3.150 (80mm)
2090 251188 ※※	-285 -80- ※※	0.020 -0.276	11.220	5.315	0.669	0.906	2.008	3.543	1.299 (1.830)	1.693	1.575	0.394	1.102 (28mm)	3.150 (80mm)
2090 251668 ※※	CAT50 -AHE1690 -165 -80- ※※	0.020 -0.394	6.496	4.646	0.866	1.260	2.283	3.543	1.752 (2.303)	2.441	2.559	0.394	1.102 (28mm)	3.150 (80mm)
2090 251698 ※※	-195 -80- ※※	0.020 -0.394	7.677	4.646	0.866	1.260	2.283	3.543	1.752 (2.303)	2.441	2.559	0.394	1.102 (28mm)	3.150 (80mm)
2090 251628 ※※	-225 -80- ※※	0.020 -0.394	8.858	4.646	0.866	1.260	2.283	3.543	1.752 (2.303)	2.441	2.559	0.394	1.102 (28mm)	3.150 (80mm)
2090 251658 ※※	-255 -80- ※※	0.020 -0.394	10.039	5.315	0.866	1.260	2.283	3.543	1.752 (2.303)	2.441	2.559	0.394	1.102 (28mm)	3.150 (80mm)
2090 252068 ※※	CAT50 -AHE2090 -165 -80- ※※	0.020 -0.512	6.496	4.646	1.102	1.378	2.638	3.543	2.008 (2.539)	2.717	2.717	0.394	1.102 (28mm)	3.150 (80mm)
2090 252098 ※※	-195 -80- ※※	0.020 -0.512	7.677	4.646	1.102	1.378	2.638	3.543	2.008 (2.539)	2.717	2.717	0.394	1.102 (28mm)	3.150 (80mm)
2090 252028 ※※	-225 -80- ※※	0.020 -0.512	8.858	4.646	1.102	1.378	2.638	3.543	2.008 (2.539)	2.717	2.717	0.394	1.102 (28mm)	3.150 (80mm)
2090 252568 ※※	CAT50 -AHE2590 -165 -80- ※※	0.020 -0.630	6.496	4.646	1.102	1.654	2.638	3.543	2.008 (2.539)	2.717	2.717	0.394	1.102 (28mm)	3.150 (80mm)
2090 252598 ※※	-195 -80- ※※	0.020 -0.630	7.677	4.646	1.102	1.654	2.638	3.543	2.008 (2.539)	2.717	2.717	0.394	1.102 (28mm)	3.150 (80mm)
2090 252528 ※※	-225 -80- ※※	0.020 -0.630	8.858	4.646	1.102	1.654	2.638	3.543	2.008 (2.539)	2.717	2.717	0.394	1.102 (28mm)	3.150 (80mm)
2090 253288 ※※	CAT50 -AHE3290 -180 -80- ※※	0.098 -0.787	7.087	4.606	1.358	1.969	2.953	4.528	2.244 (2.776)	3.110	2.953	0.394	1.102 (28mm)	3.150 (80mm)
2090 253218 ※※	-210 -80- ※※	0.098 -0.787	8.268	4.606	1.358	1.969	2.953	4.528	2.244 (2.776)	3.110	2.953	0.394	1.102 (28mm)	3.150 (80mm)
2090 253248 ※※	-240 -80- ※※	0.098 -0.787	9.449	4.606	1.358	1.969	2.953	4.528	2.244 (2.776)	3.110	2.953	0.394	1.102 (28mm)	3.150 (80mm)
2090 254098 ※※	CAT50 -AHE4090 -195 -80- ※※	0.118 -1.024	7.677	4.606	1.772	2.480	3.543	4.528	2.874 (3.406)	3.740	3.937	0.394	1.102 (28mm)	3.150 (80mm)
2090 254091 ※※	-195 -110- ※※	0.118 -1.024	7.677	4.606	1.772	2.480	3.543	4.528	2.874 (3.406)	3.740	3.937	0.394	1.102 (28mm)	4.331 (110mm)

- ※ Es para la dimensión A. Favor de consultar la pág. 185.
- Al hacer su orden, favor de especificar la medida del émbolo (dimensión "A")
- Los tipos de refrigeración a través del centro se producen según la solicitud.
- El émbolo está fijo (no es ajustable).
- La boquilla y la llave inglesa se venden por separado.

- ※ Is for A dimension. Please refer to P. 185.
- When ordering, please specify plunger size ("A" dimension).
- Center-thru coolant types are produced upon request.
- Plunger is fixed (non-adjustable)
- Collet and spanner are sold separately.

Medida Size	Boquilla Collet	Tuerca ciega Nut	Llave Inglesa Spanner
AHE1190	ER11	HDP-07A	S-0
AHE1690	ER16	ERP-16	FK0030
AHE2090	ER20	ERP-20	FK0034
AHE2590	ER25	ERP-25	HS-1-16
AHE3290	ER32	ERP-32	HS-2-20
AHE4090	ER40	ERP-40	HS-2.5-25

Boquilla Collet
Pág. 094-095



Llave Inglesa Spanner
Pág. 99



Ejemplo para Ordenar - Ordering Example

CAT40 - AH	11	90	- 165	- 65	- 06
Interfaz y diámetro de husillo Shank size	Máx. Diámetro Interno de boquilla Max. collet I.D.	Ángulo Angle	Longitud de proyección Projection length (L)	S	Dimensión A Dimension A

AHSE, AHLE

0-90° (Tipo Flexible)
(Flexible Type)

Angle Heads (ER Collet Type)

0 - 90° Tipo Flexible
Flexible Type

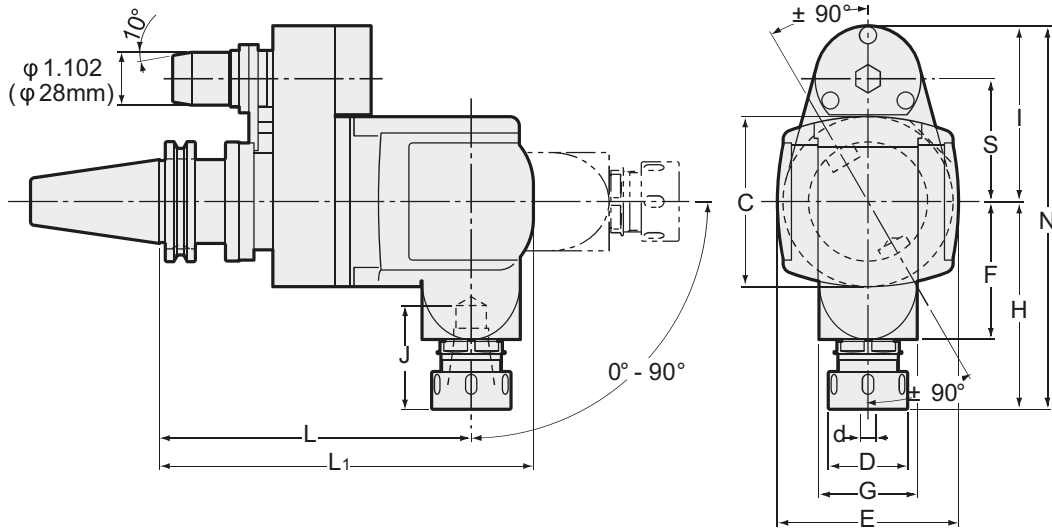

※ Necesita de un bloque de posicionamiento. Favor de consultar de la pág.185-186.
※ Requires a positioning block. Please refer to P.185-186.

Unidad : Pulgadas
Unit : Inch

Código Code	Modelo Model	d	L	L1	D	C	E	F	G	H	J	I	N	S
2084 041166 ※※	CAT40 -AHSE11 -165 -65- ※※	0.020 -0.276	6.496	7.795	0.906	3.543	3.780	2.874	2.047	3.937	2.559	3.661	7.598	2.559 (65mm)
2084 041666 ※※	CAT40 -AHSE16 -165 -65- ※※	0.020 -0.394	6.496	7.795	1.260	3.543	3.780	2.874	2.047	4.331	2.559	3.661	7.992	2.559 (65mm)
2084 042066 ※※	CAT40 -AHSE20 -165 -65- ※※	0.020 -0.512	6.496	7.795	1.378	3.543	3.780	2.874	2.047	4.331	2.165	3.661	7.992	2.559 (65mm)
2084 042566 ※※	CAT40 -AHSE25 -165 -65- ※※	0.020 -0.630	6.496	7.795	1.654	3.543	3.780	2.874	2.047	4.331	2.165	3.661	7.992	2.559 (65mm)
2084 051168 ※※	CAT50 -AHSE11 -165 -80- ※※	0.020 -0.276	6.496	7.795	0.906	3.543	3.780	2.874	2.047	3.937	2.559	4.252	8.189	3.150 (80mm)
2084 051668 ※※	CAT50 -AHSE16 -165 -80- ※※	0.020 -0.394	6.496	7.795	1.260	3.543	3.780	2.874	2.047	4.331	2.559	4.252	8.583	3.150 (80mm)
2084 052068 ※※	CAT50 -AHSE20 -165 -80- ※※	0.020 -0.512	6.496	7.795	1.378	3.543	3.780	2.874	2.047	4.331	2.165	4.252	8.583	3.150 (80mm)
2084 052568 ※※	CAT50 -AHSE25 -165 -80- ※※	0.020 -0.630	6.496	7.795	1.654	3.543	3.780	2.874	2.047	4.331	2.165	4.252	8.583	3.150 (80mm)
2084 051161 ※※	CAT50 -AHSE11 -165 -110- ※※	0.020 -0.276	6.496	7.795	0.906	3.543	3.780	2.874	2.047	3.937	2.559	5.433	9.370	4.331 (110mm)
2084 051661 ※※	CAT50 -AHSE16 -165 -110- ※※	0.020 -0.394	6.496	7.795	1.260	3.543	3.780	2.874	2.047	4.331	2.559	5.433	9.764	4.331 (110mm)
2084 052061 ※※	CAT50 -AHSE20 -165 -110- ※※	0.020 -0.512	6.496	7.795	1.378	3.543	3.780	2.874	2.047	4.331	2.165	5.433	9.764	4.331 (110mm)
2084 052561 ※※	CAT50 -AHSE25 -165 -110- ※※	0.020 -0.630	6.496	7.795	1.654	3.543	3.780	2.874	2.047	4.331	2.165	5.433	9.764	4.331 (110mm)

Código Code	Modelo Model	d	L	L1	D	C	E	F	G	H	J	I	N	S
2084 152068 ※※	CAT50 -AHLE20 -165 -80- ※※	0.020 -0.512	6.496	8.071	1.378	4.331	4.646	3.071	2.598	4.724	2.953	4.252	8.976	3.150 (80mm)
2084 152568 ※※	CAT50 -AHLE25 -165 -80- ※※	0.020 -0.630	6.496	8.071	1.654	4.331	4.646	3.071	2.598	4.724	2.953	4.252	8.976	3.150 (80mm)
2084 153268 ※※	CAT50 -AHLE32 -165 -80- ※※	0.098 -0.787	6.496	8.071	1.969	4.331	4.646	3.071	2.598	4.724	2.953	4.252	8.976	3.150 (80mm)
2084 152061 ※※	CAT50 -AHLE20 -165 -110- ※※	0.020 -0.512	6.496	8.071	1.378	4.331	4.646	3.071	2.598	4.724	2.953	5.433	10.157	4.331 (110mm)
2084 152561 ※※	CAT50 -AHLE25 -165 -110- ※※	0.020 -0.630	6.496	8.071	1.654	4.331	4.646	3.071	2.598	4.724	2.953	5.433	10.157	4.331 (110mm)
2084 153261 ※※	CAT50 -AHLE32 -165 -110- ※※	0.098 -0.787	6.496	8.071	1.969	4.331	4.646	3.071	2.598	4.724	2.953	5.433	10.157	4.331 (110mm)

Medida Size	Boquilla Collet	Tuerca ciega Nut	Llave Inglesa Spanner
AHSE11	ER11	HDP-07A	S-0
AHSE16	ER16	ERP-16	FK0030
AHSE20	ER20	ERP-20	FK0034
AHSE25	ER25	ERP-25	HS-1-16
AHLE20	ER20	ERP-20	FK0034
AHLE25	ER25	ERP-25	HS-1-16
AHLE32	ER32	ERP-32	HS-2-20

- ※ Es para la dimensión A. Favor de consultar la pág. 185.
- Al hacer su orden, favor de especificar la medida del émbolo (dimensión "A")
- Los tipos de refrigeración a través del centro se producen según la solicitud.
- El émbolo está fijo (no es ajustable).
- Boquilla y llave inglesa se venden por separado.

- ※ Is for A dimension. Please refer to P. 185.
- When ordering, please specify plunger size ("A" dimension).
- Center-thru coolant types are produced upon request.
- Plunger is fixed (non-adjustable)
- Collet and spanner are sold separately.

Boquilla Collet
Pág. 094-095



Llave Inglesa Spanner
Pág. 99



Ejemplo para Ordenar - Ordering Example

CAT40 - AHSE	11	- 165	- 65	- 06
Interfaz y diámetro de husillo Shank size	Máx. Diámetro Interno de boquilla Max. collet I.D.	Longitud de proyección Projection length (L)	S	Dimensión A Dimension A

- BT
- CAT
- AHO
- HSK-A/E/F/C
- HSK-T
- C
- UTS
- Máquinas Especializadas
Specialized Machine
- Equipo Relacionado
Related Equipment
- Taladro de Biselado & de Casquillo
Bush & Chamfering Drill
- Milling Chuck
- Collet Holder
- "R" Zero Holder
- Hydraulic Chuck
- Shrink Fit
- Tapping Chuck
- Arbors
- Function Holder
- Retention Stud
- Tool Shank Dimensions

HDC·A-CS

Collet type Coolant Inducer

Tipo1
Type1

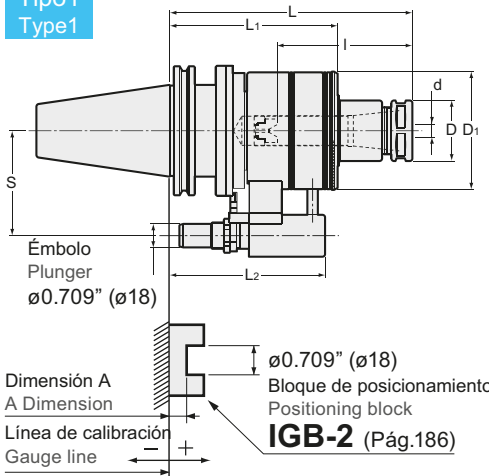

Tipo2
Type2

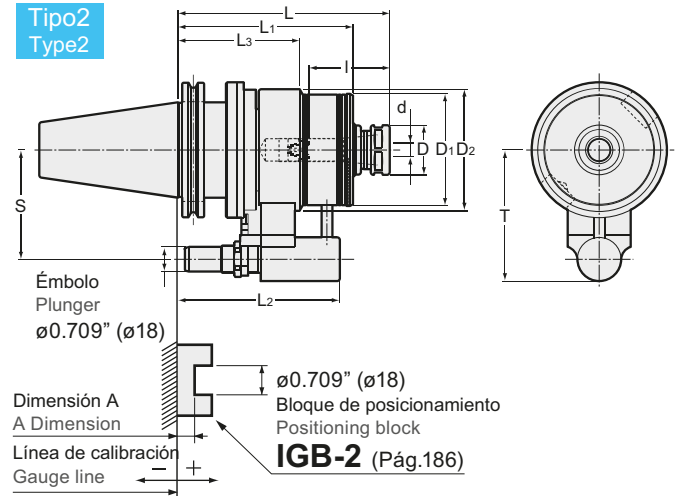

Unidad : Pulgadas
Unit : Inch

Código Code	Modelo Model	Tipo Type	d	L	B	I	L1	L2	L3	D	D1	D2	T	S	MAX min ⁻¹	Refrigerante Máx - Max. Coolant	Retén para ejes Seal Unit
1890 8416150 ※	CAT40 -HDC16A -150CS- ※	2	0.236 -0.630	5.910	0.0 -0.236	1.496 -2.559	5.079	4.704	3.543	1.417	3.228	3.504	3.189	2.559 (65mm)	6,000	2MPa	CS-2
1890 8422165 ※	CAT40 -HDC22A -165CS- ※	1	0.236 -0.866	6.500	0.0 -0.315	1.860 -4.055	5.079	4.704	—	1.811	3.543	—	3.189	2.559 (65mm)	5,000	2MPa	CS-3
1890 8516155 ※	CAT50 -HDC16A -155CS- ※	2	0.236 -1.630	6.100	0.0 -0.236	1.496 -2.559	5.039	4.665	3.504	1.417	3.228	3.504	3.780	3.150 (80mm)	6,000	2MPa	CS-2
1890 8522185 ※	CAT50 -HDC22A -185CS- ※	1	0.236 -0.866	7.280	0.0 -0.315	1.860 -4.055	5.039	4.665	—	1.811	3.543	—	3.780	3.150 (80mm)	5,000	2MPa	CS-3

Tipo Type	Tabla del émbolo - Plunger No.					
	No.1	No.2	No.3	No.4	No.5	
	A	A	A	A	A	
CAT40	HDC-A	+1.299" ~ +0.909" (+33mm ~ +23.1mm)	+0.906" ~ +0.516" (+23mm ~ +13.1mm)	+0.512" ~ +0.122" (+13mm ~ +3.1mm)	+0.118" ~ -0.272" (+3mm ~ -6.9mm)	-0.276" ~ -0.665" (-7mm ~ -16.9mm)
CAT50	HDC-A	+1.417" ~ +1.027" (+36mm ~ +26.1mm)	+1.023" ~ +0.633" (+26mm ~ +16.1mm)	+0.629" ~ +0.240" (+16mm ~ +6.1mm)	+0.236" ~ -0.153" (+6mm ~ -3.9mm)	-0.157" ~ -0.547" (-4mm ~ -13.9mm)

Modelo Model	Tuerca ciega Nut	Boquilla Collet	Llave Inglesa Spanner
HDC16A	HDP-16	FDC-16-OH,-C	S-4L
HDC22A	HDC-22	FDC-22-OH,-C	S-5L

Unidad de sellado Seal unit
Pág. 184

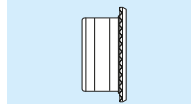

Boquilla Collet
Pág. 090-093

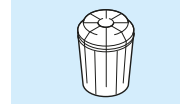

Llave Inglesa Spanner
Pág. 099



1. La boquilla refrigerante y la llave inglesa se venden por separado.
2. Al hacer su orden, favor de especificar el número de émbolo (No.1~No.5).
3. El émbolo es ajustable. Favor de dirigirse a una tabla de arriba.
4. Dirijase a la pág. 096 para conocer la longitud mínima de inserción de herramienta en caso de usar su boquilla refrigerante (OH,C).
5. Las dimensiones l 1 entre corchetes son para usar el tornillo de preajuste.
6. El cliente puede reemplazar la unidad de sellado.

1. Coolant collet and spanner are sold separately.
2. When ordering, please specify the plunger number(No.1~No.5).
3. Plunger is adjustable. Please refer to a chart on the right.
4. Refer to P. 096 for minimum tool insertion length in case of using our coolant collets (OH,C).
5. l 1 dimensions in brackets are for using preset screw.
6. Seal unit can be replaced by customer.

Ejemplo para Ordenar - Ordering Example

CAT40 - HDC	07	A -	165	CS -	1
Interfaz y diámetro de husillo Shank size	Máx. Diámetro Interno de boquilla Max. collet I.D.	Longitud de proyección Projection length (L)	Émbolo No. Plunger No.		

CT·SA·CS

Super Tite-Lock Milling Chuck (Coolant Inducer)

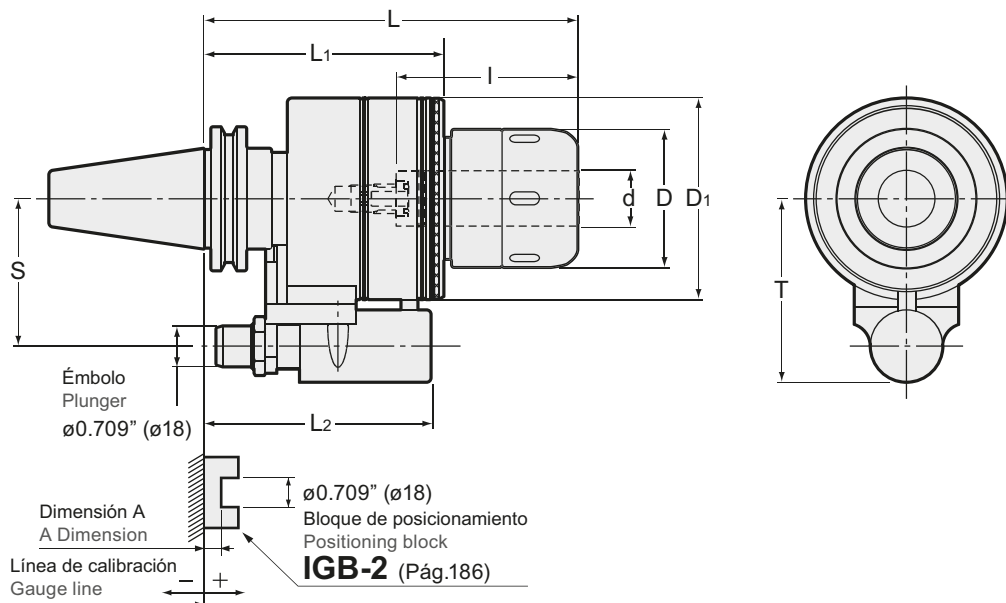

Medida en Pulgadas - Inch Sizes

Unidad : Pulgadas
Unit : Inch

Código Code	Modelo Model	d	L	B	L1	L2	D	D1	D2	T	S	MAX _{min} ¹	Refrigerante máx. Max. Coolant	Unidad de sellado Seal unit	kg	Llave Inglesa Spanner
1890 9424195 ※	CAT40-CT0750SA-195CS- ※	0.750	7.677	2.756	4.923	4.549	2.047	3.543	3.504	3.189	2.559 (65mm)	5,000	2MPa	CS-3		HS-2-20
1890 9440195 ※	CAT40-CT1250SA-195CS- ※	1.250	7.677	3.150	5.039	4.587	2.874	3.937	-	3.189	2.559 (65mm)	4,000	2MPa	CS-4		HS-3-32
1890 9524200 ※	CAT50-CT0750SA-200CS- ※	0.750	7.874	2.756	5.039	4.665	2.047	3.543	3.504	3.780	3.150 (80mm)	5,000	2MPa	CS-3		HS-2-20
1890 9540200 ※	CAT50-CT1250SA-200CS- ※	1.250	7.874	3.150	5.118	4.665	2.874	3.937	-	3.780	3.150 (80mm)	4,000	2MPa	CS-4	10.2	HS-3-32

Tipo Type		Tabla del émbolo - Plunger No.				
		No.1	No.2	No.3	No.4	No.5
CAT40	CT	A	A	A	A	A
CAT50	CT	+0.909 ~ +1.299	+0.516 ~ +0.906	+0.122 ~ +0.512	-0.271 ~ +0.118	-0.665 ~ -0.276

1. Al hacer su orden, favor de especificar el número de émbolo (No.1~No.5).
2. El émbolo es ajustable. Favor de consultar la tabla superior.
3. Favor de regresarnos su portaherramienta de refrigerante a través de su vendedor para reemplazar la unidad selladora.
4. Al hacer su orden, indique el número de llaves que necesitará. Las llaves de torque "gratuitas" están limitadas al número de portaherramientas de fresado que ordene.
5. Los accesorios no se pueden usar, excepto para el MC-C y el MC-OH.
6. La tolerancia del zanco de la herramienta de corte debe ser de h7.

1. When ordering, please specify the plunger number (No.1~No.5).
2. Plunger is adjustable. Please refer to a chart above.
3. Please return your coolant holder to us through your dealer for seal unit replacement.
4. When ordering, indicate number of spanners required. "No charge" spanners are limited to number of milling chucks on order.
5. Accessories cannot be used except for MC-C and MC-OH.
6. Tolerance of cutting tool shank must be h7.

Boquilla
MC-OH, MC-C Collet
Pág. 070-071

Unidad de sellado
Seal unit
Pág. 184

Llave Inglesa
Spanner
Pág. 073

Ejemplo para Ordenar - Ordering Example

CAT40 - CT 0750 S - 195 CS - 1			
Interfaz y diámetro de husillo Shank size	Diámetro Interno I.D. (d)	Longitud de proyección Projection length (L)	Émbolo No. Plunger No.



Alimentación de refrigerante Coolant Feeding

La alimentación de refrigerante interno es posible al remplazar la boquilla estándar ER con la boquilla tipo ER-OH. Para mayor información, favor de contactar con NT TOOL.

Internal coolant feeding is possible by replacing the collet with ER-OH type collet. Please contact NT TOOL for details.



ER-OH
Para herramienta de corte con vena de lubricación
For cutting tool with coolant hole

¡Refrigerante por centro sin anillos de sellado o tapones de refrigerante! Center-Thru Coolant Without Sealing Rings or Coolant Caps!

Al utilizar boquillas ER-OH con sellado mecánico, el portaherramienta NT Mevius soporta refrigeración por centro sin partes adicionales. La boquilla ER-OH son fabricadas con ranuras selladas construidas dentro del mismo cuerpo de la boquilla, lo que previene cualquier fuga de refrigerante.

Cuando cambie las medidas de la herramienta, ahora sólo es necesario retirar la boquilla, ¡sin preocuparse de comprar un anillo de sellado!

Para cualquier pregunta acerca de la boquilla ER-OH o del portaherramienta NT Mevius, favor de contactar a NT TOOL DE MEXICO S.A. DE C.V. para mayor información.

By using metal-sealed ER-OH style collets, the NT Mevius holder supports center-thru coolant without any additional parts. The ER-OH collets are manufactured with sealed slits built into the body of the collet itself, which prevent any coolant leakage. When switching tool sizes, it is now only necessary to switch out the collet, without worrying about buying a matching sealing ring or cap! For any questions about the ER-OH collets or the NT Mevius holder, please contact NT USA for details.

CAT40 Portaherramienta de boquilla ER Modelo - MDE ER CAT40 Collet Holders Type - MDE

Tipo 1
Type 1

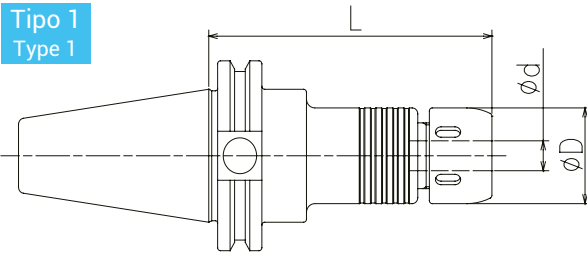

Tipo 2
Type 2

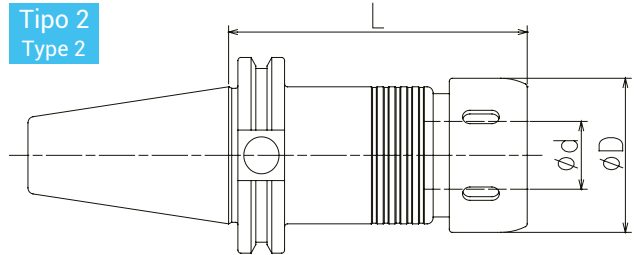

Código Code	Modelo Model	Tipo Type	d Diámetro de sujeción d Chucking range	D	L	Modelo de boquilla Collet Series	Tuerca ciega Cap	Llave Inglesa Spanner	Tornillo preajustado Preset Screw
254206152000	CAT40 -MDE16 -3"	1	1/16"~13/32" (0.5~10.0mm)	1.259"	3"	ER16	MDEP-16	FK-0030	ES16
254206122000	-4"	1		1.259"	4"				
254206153000	-6"	1		1.259"	6"				
254206154000	-MDE20 -3"	1	1/16"~1/2" (0.5~13.0mm)	1.377"	3"	ER20	MDEP-20	FK-0034	HDS12A-ES20
254206123000	-4"	1		1.377"	4"				
254206155000	-6"	1		1.377"	6"				
254206156000	-MDE25 -3"	1	1/16"~5/8" (0.5~17.0mm)	1.653"	3"	ER25	MDEP-25	FK-0040	HDS16A-ES25
254206157000	-4"	1		1.653"	4"				
254206158000	-6"	1		1.653"	6"				
254206159000	-MDE32 -3"	2	1/8"~3/4" (1.0~22.0mm)	1.968"	3"	ER32	MDEP-32	FK-0052	HDS22A-ES32
254206124000	-4"	2		1.968"	4"				
254206160000	-6"	2		1.968"	6"				

● Llave Inglesa, Boquilla y Tornillo de preajuste se venden por separado.

● Spanner, Collet and Preset screw are sold separately.

Ejemplo para Ordenar / Ordering Example

CAT40 - MDE16 - 3"

Configuración
de husillo
Shank size

Número de
Boquilla ER
ER collet
number

Longitud
de proyección
Projection length

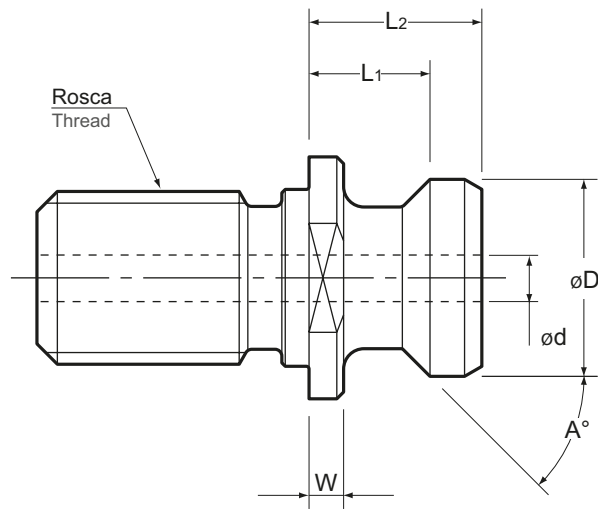

Unidad : Pulgadas
Unit : Inch

Modelo Model	D	L1	L2	Ángulo Angle	W	Cuerda Thread	d	Interfaz y diámetro del husillo Shank size	Descripción Description
PSC40-1	0.74	0.440	0.64	45°	0.12	5/8"-11	0.275	CAT40	Estándar ANSI, con orificio para refrigerante ANSI Standard , With a coolant hole
PSC50-1	1.14	0.700	1.00	45°	0.20	1"-8	0.464	CAT50	Estándar ANSI, con orificio para refrigerante ANSI Standard , With a coolant hole

Favor de revisar que las dimensiones estén dentro de las especificaciones del husillo de su máquina
Please check dimensions with your machine spindle specs.

Dimensiones del zanco de herramienta para el CAT Tool Shank Dimensions For CAT

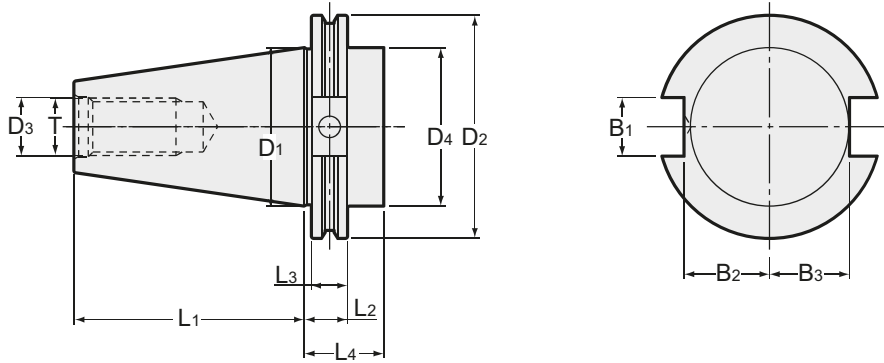

Unidad : Pulgadas
Unit : Inch

Modelo Model	D1	D2	D3	D4	T	L1	L2	L3	L4	B1	B2	B3
CAT40	1.750	2.500	0.641	1.750	5/8"-11	2.687	0.750	0.625	1.38Min.	0.645	0.985	0.890
CAT50	2.750	3.875	1.031	2.750	1"-8	4.000	0.750	0.625	1.38Min.	1.020	1.485	1.390

BT

CAT

AHO

HSK-A/E/F/C

HSK-T

C

UTS

Máquinas
Especializadas
Specialized
MachineEquipo
Relacionado
Related
EquipmentTaladro de
Biselado & de
Casquillo
Bush &
Chamfering
Drill

Milling Chuck

Collet Holder

"R" Zero Holder

Hydraulic
Chuck

Shrink Fit

Tapping Chuck

Anvils

Function
Holder

Retention Stud

Tool Shank
Dimensions



A H O

SISTEMA DE HERRAMENTADO AHO
AHO TOOLING SYSTEM

Super tite-lock Milling Chuck

- Super tite-lock Milling chuck delgado. Sus ranuras tienen un diseño especial para permitir desbastes pesados.
- Slim design milling chuck. Specially designed slits enable heavy endmilling.

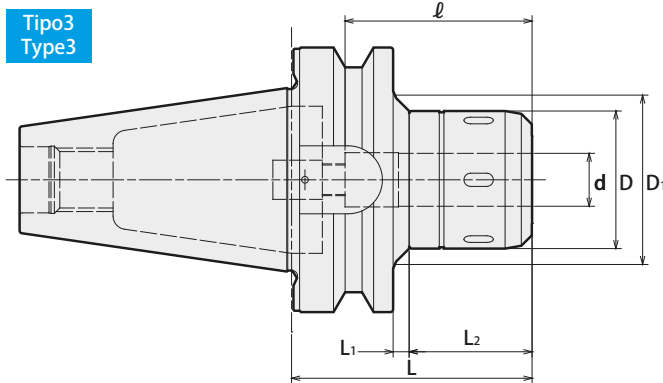
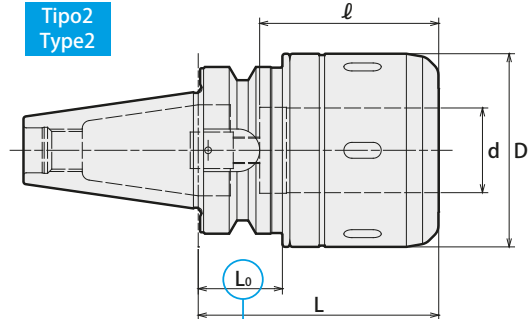
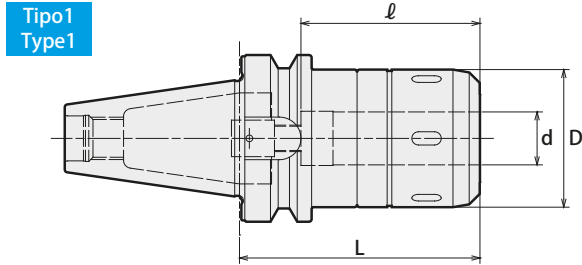

⚠ Precaución/Caution

- ★ : Tenga precaución con la interferencia del brazo A.T.C. (automatic tool changer) y el cartucho.
Take caution against A.T.C. arm and tool magazine interference.

Precaución/Caution

- Favor de girar el aro de sujeción en sentido contrario a las manecillas del reloj por más de 360 grados después de quitar una herramienta de corte.
Please rotate the clamping ring counterclockwise more than 360 degrees after a cutting tool is removed.



- Cuando el modelo "AHO" es utilizado con alimentación de refrigerante que pasa a través del centro del portaherramienta, debe utilizarse un tornillo de retención diseñado para AHO (con pipa de refrigerante).
- When AHO is used with center through coolant feeding, a designated retention stud (with coolant pipe) for AHO must be used.

Medidas Métricas - Metric Sizes

Unidad : Métrico
Unit : Metric

Código Code	Modelo Model	Tipo Type	d	D	D ₁	L	L ₁	L ₂	ℓ	L ₀	kg	Tornillo de retención Stopper Bolt	Llave Inglesa Spanner		
3860 ※ 0010100	WBT-AHO30 or NBT-AHO30 -CT16SA -75	* 1	16	45	—	75	—	—	55	—	0.9	Inutilizable / Unusable	HS- 1 -16		
3860 ※ 0020100	-90	1	16	45	—	90	—	—	70	—	1.0				
3860 ※ 0030100	-CT20SA -75	* 2	20	52	—	75	—	—	55	★ 27	1.0		HS- 2 -20		
3860 ※ 0040100	-90	* 1	2	20	52	—	—	—	70	40	1.1				
3860 ※ 0050100	-105	2	20	52	—	105	—	—	80	55	1.3				
3860 ※ 0060100	-CT25SA -90	* 1	2	25	61	—	—	—	70	★ 31	1.4			HS-2.5 -25	
3860 ※ 0070100	-105	2	25	61	—	105	—	—	80	44	1.6				
3860 ※ 0080100	-CT32SA -90	2	32	68	—	90	—	—	68	★ 30	1.6			HS- 3 -32	
3860 ※ 0090100	WBT-AHO40 or NBT-AHO40 -CT16SA -75	1	16	45	—	75	—	—	60	—	1.3	Inutilizable / Unusable	HS- 1 -16		
3860 ※ 0100100	-90	1	16	45	—	90	—	—	65	—	1.4				
3860 ※ 0110100	-CT20SA -75	* 1	1	20	52	—	75	—	60	—	1.4		HS- 2 -20		
3860 ※ 0120100	-90	1	20	52	—	90	—	—	75	—	1.6				
3860 ※ 0130100	-105	1	20	52	—	105	—	—	80	—	1.8				
3860 ※ 0140100	-120	1	20	52	—	120	—	—	80	—	2.1			BL20- ※※	
3860 ※ 0150100	-CT25SA -90	1	25	61	—	90	—	—	75	—	1.9			Inutilizable / Unusable	HS-2.5 -25
3860 ※ 0160100	-105	1	25	61	—	105	—	—	80	—	2.2				
3860 ※ 0170100	-120	1	25	61	—	120	—	—	80	—	2.5	BL20- ※※			
3860 ※ 0180100	-135	1	25	61	—	135	—	—	80	—	2.8				
3860 ※ 0190100	-CT32SA -90	* 1	2	32	73	—	90	—	75	★ 31	2.2	Inutilizable / Unusable	HS- 3 -32		
3860 ※ 0200100	-105	* 1	2	32	73	—	105	—	85	44	2.5				
3860 ※ 0210100	-120	* 1	2	32	73	—	120	—	90	59	2.8				
3860 ※ 0220100	-135	2	32	73	—	135	—	—	105	74	3.1			BL20- ※※	

Medidas Métricas - Metric Sizes

Unidad : Métrico
Unit : Metric



Código Code	Modelo Model	Tipo Type	d	D	D ₁	L	L ₁	L ₂	ℓ	L ₀	kg	Tornillo de retención Stopper Bolt	Llave Inglesa Spanner		
3860 ※ 0230100	WBT-AHO50 or NBT-AHO50 -CT16SA -90	3	16	45	58	90	7	45	65	—	3.4	Inutilizable / Unusable	HS- 1 -16		
3860 ※ 0240100	-105	3	16	45	70	105	22	45	65	—	3.7	BL16- * *			
3860 ※ 0250100	-CT20SA -90	* 1	3	20	52	65	90	7	45	65	—	3.5	Inutilizable / Unusable	HS- 2 -20	
3860 ※ 0260100	-105	3	20	52	65	105	9	60	80	—	3.7				
3860 ※ 0270100	-120	3	20	52	70	120	24	58	80	—	4.1				
3860 ※ 0280100	-135	3	20	52	73	135	39	58	80	—	4.5				
3860 ※ 0290100	-CT25SA -105	3	25	61	82	105	11	56	80	—	4.0	Inutilizable / Unusable			
3860 ※ 0300100	-120	3	25	61	82	120	26	56	80	—	4.5	BL20- * *	HS-2.5 -25		
3860 ※ 0310100	-135	3	25	61	83	135	41	56	80	—	5.0				
3860 ※ 0320100	-165	3	25	61	86	165	71	56	80	—	6.0				
3860 ※ 0330100	-CT32SA -95	* 1	1	32	73	—	95	—	75	—	4.1	Inutilizable / Unusable	HS- 3 -32		
3860 ※ 0340100	-105	* 1	1	32	73	—	105	—	85	—	4.3				
3860 ※ 0350100	-120	3	32	73	87	120	26	56	100	—	4.9				
3860 ※ 0360100	-135	3	32	73	88	135	41	56	105	—	5.5				
3860 ※ 0370100	-150	3	32	73	87	150	56	56	110	—	6.0				
3860 ※ 0380100	-165	3	32	73	86	165	71	56	120	—	6.5				
3860 ※ 0390100	-CT42SA -95	* 2	1	42	88	—	95	—	75	—	4.5			Inutilizable / Unusable	HS- 4 -42
3860 ※ 0400100	-105	* 1	1	42	88	—	105	—	85	—	4.9				
3860 ※ 0410100	-120	* 1	1	42	88	—	120	—	100	—	5.5				
3860 ※ 0420100	-135	* 1	1	42	88	—	135	—	105	—	6.1				
3860 ※ 0430100	-150	* 1	1	42	88	—	150	—	110	—	6.8				
3860 ※ 0440100	-165	1	42	88	—	165	—	—	120	—	7.4				

Favor de reemplazar ※ en el código con Ø para el NBT-AHO y con 6 para el WBT-AHO.
Please replace ※ in the code with Ø for NBT-AHO and 6 for WBT-AHO.

- Al hacer su orden, indique el número de llaves que necesitará. Las llaves Inglesa "gratuitas" están limitadas al número de portaherramientas de fresado que ordene.
 - La tolerancia del zanco de la herramienta de corte debe ser de h7.
 - La boquilla recta MCA no se puede usar.
- When ordering, indicate number of spanners required. "Complimentary" spanners are limited to number of milling chucks on order.
 - Tolerance of cutting tool shank must be h7.
 - Straight collet MCA cannot be used.

Accesorios Accessories

Los modelos con * 1- * 4 no pueden usarse con algunos accesorios debido a la corta ℓ longitud.
Models with * 1 - * 4 cannot be used with some accessories due to short ℓ length.

	Boquilla recta Straight Collet 		Adaptador de zanco Morse Morse Taper Adapter 		Adaptador Jacobs Jacobs Adapter 	
	MC (Pág.070)	MCA (Pág.071)	MA (Pág.072)	MAB (Pág.072)	JA (Pág.073)	JAB (Pág.073)
* 1	Sí / Yes	No	No	No	No	No
* 2	Sí / Yes	No	No	Sí / Yes	No	Sí / Yes

Longitud Mínima de inserción Min. chucking length

Sin boquilla MC
Without MC collet

D.I. del portaherramienta de fresado I.D. of Milling Chuck	Longitud Mín. de inserción Min. chucking length
16, 20	40
25, 32, 42	50

Con boquilla MC
With MC collet

D.I. de la boquilla Collet I.D.	Longitud Mín. de inserción Min. chucking length	
	MC	MC-C, MC-OH
6, 8	30	30
10, 12	40	40
16, 20	45	45
25	50	50
32	50	60

Ejemplo para Ordenar - Ordering Example

Correspondiente a nuestro zanco con contacto de doble cara BT
Corresponding to our two-face contact BT spindle

NBT-AHO30 - CT 16 SA - 75

Interfaz y diámetro de husillo AHO AHO Shank size
Diámetro Interno I.D. (d)
Longitud de proyección Projection length (L)

Ejemplo para Ordenar - Ordering Example

Correspondiente al zanco con contacto de doble cara BT
Corresponding to BT two-face contact spindle

WBT-AHO30 - CT 16 SA - 75

Interfaz y diámetro de husillo AHO AHO Shank size
Diámetro Interno I.D. (d)
Longitud de proyección Projection length (L)

Llave Inglesa Spanner

Pág. 073

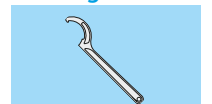

High-Precision Collet Holder

- Adecuado para barrenado, rima y acabado en fresa.
- Suitable for drilling, reaming and finish endmilling.

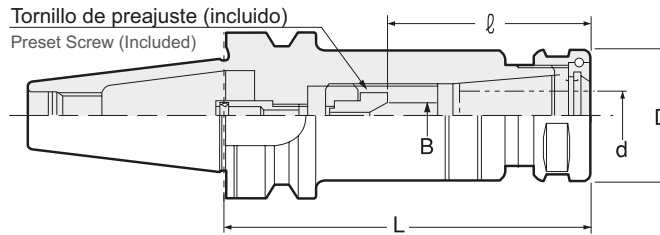

- Nuestro portaherramientas NBT de doble contacto es incompatible con el portaherramientas BT de doble contacto (para WBT-AHO). Por favor consultar pág. 43
- Cuando el modelo "AHO" es utilizado con alimentación de refrigerante que pasa a través del centro del portaherramienta, debe utilizarse un tornillo de retención diseñado para AHO (con pipa de refrigerante).
- Our two-face contact NBT spindle is incompatible with BT two-face contact spindle (for WBT-AHO). Please refer to p.43
- When AHO is used with center through coolant feeding, a designated retention stud (with coolant pipe) for AHO must be used.

Unidad : Métrico
Unit : Metric

Código Code	Modelo Model	d	L	ℓ	B	D	Tuerca ciega Nut	kg	Boquilla Collet	Llave Inglesa Spanner
3830 ※ 0640000	NBT-AHO30 or WBT-AHO30 -HDC07A -45	0.5 ~ 7.0	45	26	—	23	HDP-07A			
3830 ※ 0650000	-60	0.5 ~ 7.0	60	22 ~ 23	0 ~ 4	23	HDP-07A	0.5	FDC-07	S-0
3830 ※ 0660000	-75	0.5 ~ 7.0	75	22 ~ 38	0 ~ 4	23	HDP-07A	0.5		
3830 ※ 0670000	-90	0.5 ~ 7.0	90	22 ~ 45	0 ~ 4	23	HDP-07A	0.5		
3830 ※ 0680000	-105	0.5 ~ 7.0	105	22 ~ 45	0 ~ 4	23	HDP-07A	0.5		
3830 ※ 0690000	NBT-AHO30 or WBT-AHO30 -HDC09A -60	2.5 ~ 9.0	60	40	—	26	HDP-09			
3830 ※ 0700000	-75	2.5 ~ 9.0	75	27 ~ 40	0 ~ 4	26	HDP-09	0.5	FDC-09	S-1L
3830 ※ 0710000	-90	2.5 ~ 9.0	90	27 ~ 50	0 ~ 4	26	HDP-09	0.6		
3830 ※ 0720000	-105	2.5 ~ 9.0	105	27 ~ 57	0 ~ 4	26	HDP-09	0.6		
3830 ※ 0850000	-120	2.5 ~ 9.0	120	27 ~ 57	0 ~ 4	26	HDP-09	0.7		
3830 ※ 0730000	NBT-AHO30 or WBT-AHO30 -HDC12A -60	2.5 ~ 12.0	60	40	—	32	HDP-12	0.5		
3830 ※ 0740000	-75	2.5 ~ 12.0	75	33 ~ 40	0 ~ 5	32	HDP-12	0.6	FDC-12	S-3L
3830 ※ 0750000	-90	2.5 ~ 12.0	90	33 ~ 55	0 ~ 5	32	HDP-12	0.7		
3830 ※ 0760000	-105	2.5 ~ 12.0	105	33 ~ 65	0 ~ 5	32	HDP-12	0.7		
3830 ※ 0860000	-120	2.5 ~ 12.0	120	33 ~ 69	0 ~ 5	32	HDP-12	0.7		
3830 ※ 0770000	NBT-AHO30 or WBT-AHO30 -HDC16A -75	3.5 ~ 16.0	75	38 ~ 41	0 ~ 6	36	HDP-16			
3830 ※ 0780000	-90	3.5 ~ 16.0	90	38 ~ 50	0 ~ 6	36	HDP-16	0.7	FDC-16	S-4L
3830 ※ 0790000	-105	3.5 ~ 16.0	105	38 ~ 65	0 ~ 6	36	HDP-16	0.8		
3830 ※ 0800000	-120	3.5 ~ 16.0	120	38 ~ 80	0 ~ 6	36	HDP-16	0.9		
3830 ※ 0820000	NBT-AHO30 or WBT-AHO30 -HDC22A -75	3.5 ~ 22.0	75	56	—	46	HDP-22	0.7		
3830 ※ 0830000	-90	3.5 ~ 22.0	90	47 ~ 54	0 ~ 8	46	HDP-22	0.9	FDC-22	S-5L
3830 ※ 0840000	-105	3.5 ~ 22.0	105	47 ~ 69	0 ~ 8	46	HDP-22	1.0		
3830 ※ 0880000	-120	3.5 ~ 22.0	120	47 ~ 75	0 ~ 8	46	HDP-22	1.2		
3830 ※ 0870000	NBT-AHO40 or WBT-AHO40 -HDC07A -75	0.5 ~ 7.0	75	22 ~ 35	0 ~ 4	23	HDP-07A	0.9		
3830 ※ 0010000	-90	0.5 ~ 7.0	90	22 ~ 45	0 ~ 4	23	HDP-07A	0.9	FDC-07	S-0
3830 ※ 0020000	-105	0.5 ~ 7.0	105	22 ~ 45	0 ~ 4	23	HDP-07A	0.9		
3830 ※ 0030000	-120	0.5 ~ 7.0	120	22 ~ 45	0 ~ 4	23	HDP-07A	0.9		
3830 ※ 0890000	-135	0.5 ~ 7.0	135	22 ~ 45	0 ~ 4	23	HDP-07A	0.9		
3830 ※ 0040000	NBT-AHO40 or WBT-AHO40 -HDC09A -90	2.5 ~ 9.0	90	27 ~ 55	0 ~ 4	26	HDP-09			
3830 ※ 0050000	-105	2.5 ~ 9.0	105	27 ~ 57	0 ~ 4	26	HDP-09	1.1	FDC-09	S-1L
3830 ※ 0060000	-120	2.5 ~ 9.0	120	27 ~ 57	0 ~ 4	26	HDP-09	1.1		
3830 ※ 0070000	-135	2.5 ~ 9.0	135	27 ~ 57	0 ~ 4	26	HDP-09	1.1		
3830 ※ 0080000	-165	2.5 ~ 9.0	165	27 ~ 57	0 ~ 4	26	HDP-09	1.1		
3830 ※ 0090000	NBT-AHO40 or WBT-AHO40 -HDC12A -90	2.5 ~ 12.0	90	33 ~ 55	0 ~ 5	32	HDP-12	1.1		
3830 ※ 0100000	-105	2.5 ~ 12.0	105	33 ~ 69	0 ~ 5	32	HDP-12	1.2	FDC-12	S-3L
3830 ※ 0110000	-120	2.5 ~ 12.0	120	33 ~ 69	0 ~ 5	32	HDP-12	1.3		
3830 ※ 0120000	-135	2.5 ~ 12.0	135	33 ~ 69	0 ~ 5	32	HDP-12	1.3		
3830 ※ 0130000	-165	2.5 ~ 12.0	165	33 ~ 69	0 ~ 5	32	HDP-12	1.5		
3830 ※ 0140000	-195	2.5 ~ 12.0	195	33 ~ 69	0 ~ 5	32	HDP-12	1.5		

Código Code	Modelo Model	d	L	ℓ	B	D	Tuerca ciega Nut	kg	Boquilla Collet	Llave Inglesa Spanner
3830 ※ 0150000	NBT-AHO40 or WBT-AHO40 -HDC16A -90	3.5 ~ 16.0	90	38 ~ 55	0 ~ 6	36	HDP-16		FDC-16	S-4L
3830 ※ 0160000	-105	3.5 ~ 16.0	105	38 ~ 70	0 ~ 6	36	HDP-16	1.2		
3830 ※ 0170000	-120	3.5 ~ 16.0	120	38 ~ 82	0 ~ 6	36	HDP-16	1.3		
3830 ※ 0180000	-135	3.5 ~ 16.0	135	38 ~ 82	0 ~ 6	36	HDP-16			
3830 ※ 0190000	-165	3.5 ~ 16.0	165	38 ~ 82	0 ~ 6	36	HDP-16			
3830 ※ 0200000	-195	3.5 ~ 16.0	195	38 ~ 82	0 ~ 6	36	HDP-16			
3830 ※ 0210000	NBT-AHO40 or WBT-AHO40 -HDC22A -105	3.5 ~ 22.0	105	47 ~ 65	0 ~ 8	46	HDP-22	1.4	FDC-22	S-5L
3830 ※ 0220000	-120	3.5 ~ 22.0	120	47 ~ 80	0 ~ 8	46	HDP-22			
3830 ※ 0230000	-135	3.5 ~ 22.0	135	47 ~ 95	0 ~ 8	46	HDP-22			
3830 ※ 0240000	-165	3.5 ~ 22.0	165	47 ~ 103	0 ~ 8	46	HDP-22			
3830 ※ 0250000	-195	3.5 ~ 22.0	195	47 ~ 103	0 ~ 8	46	HDP-22			
3830 ※ 0260000	NBT-AHO50 or WBT-AHO50 -HDC07A -90	0.5 ~ 7.0	90	22 ~ 45	0 ~ 4	23	HDP-07A			
3830 ※ 0270000	-105	0.5 ~ 7.0	105	22 ~ 45	0 ~ 4	23	HDP-07A			
3830 ※ 0280000	-120	0.5 ~ 7.0	120	22 ~ 45	0 ~ 4	23	HDP-07A			
3830 ※ 0290000	-135	0.5 ~ 7.0	135	22 ~ 45	0 ~ 4	23	HDP-07A			
3830 ※ 0300000	-165	0.5 ~ 7.0	165	22 ~ 45	0 ~ 4	23	HDP-07A			
3830 ※ 0310000	-195	0.5 ~ 7.0	195	22 ~ 45	0 ~ 4	23	HDP-07A			
3830 ※ 0320000	NBT-AHO50 or WBT-AHO50 -HDC09A -90	2.5 ~ 9.0	90	27 ~ 47	0 ~ 4	26	HDP-09		FDC-09	S-1L
3830 ※ 0330000	-105	2.5 ~ 9.0	105	27 ~ 57	0 ~ 4	26	HDP-09			
3830 ※ 0340000	-120	2.5 ~ 9.0	120	27 ~ 57	0 ~ 4	26	HDP-09			
3830 ※ 0350000	-135	2.5 ~ 9.0	135	27 ~ 57	0 ~ 4	26	HDP-09			
3830 ※ 0360000	-165	2.5 ~ 9.0	165	27 ~ 57	0 ~ 4	26	HDP-09			
3830 ※ 0370000	-195	2.5 ~ 9.0	195	27 ~ 57	0 ~ 4	26	HDP-09			
3830 ※ 0380000	-225	2.5 ~ 9.0	225	27 ~ 57	0 ~ 4	26	HDP-09			
3830 ※ 0390000	-255	2.5 ~ 9.0	255	27 ~ 57	0 ~ 4	26	HDP-09			
3830 ※ 0400000	NBT-AHO50 or WBT-AHO50 -HDC12A -90	3.5 ~ 12.0	90	33 ~ 47	0 ~ 5	32	HDP-12	3.1	FDC-12	S-3L
3830 ※ 0410000	-105	3.5 ~ 12.0	105	33 ~ 62	0 ~ 5	32	HDP-12			
3830 ※ 0420000	-120	3.5 ~ 12.0	120	33 ~ 69	0 ~ 5	32	HDP-12			
3830 ※ 0430000	-135	3.5 ~ 12.0	135	33 ~ 69	0 ~ 5	32	HDP-12			
3830 ※ 0440000	-165	3.5 ~ 12.0	165	33 ~ 69	0 ~ 5	32	HDP-12			
3830 ※ 0450000	-195	3.5 ~ 12.0	195	33 ~ 69	0 ~ 5	32	HDP-12			
3830 ※ 0460000	-225	3.5 ~ 12.0	225	33 ~ 69	0 ~ 5	32	HDP-12			
3830 ※ 0470000	-255	3.5 ~ 12.0	255	33 ~ 69	0 ~ 5	32	HDP-12			
3830 ※ 0480000	NBT-AHO50 or WBT-AHO50 -HDC16A -90	3.5 ~ 16.0	90	38 ~ 48	0 ~ 6	36	HDP-16		FDC-16	S-4L
3830 ※ 0490000	-105	3.5 ~ 16.0	105	38 ~ 63	0 ~ 6	36	HDP-16			
3830 ※ 0500000	-120	3.5 ~ 16.0	120	38 ~ 78	0 ~ 6	36	HDP-16			
3830 ※ 0510000	-135	3.5 ~ 16.0	135	38 ~ 82	0 ~ 6	36	HDP-16			
3830 ※ 0520000	-165	3.5 ~ 16.0	165	38 ~ 82	0 ~ 6	36	HDP-16			
3830 ※ 0530000	-195	3.5 ~ 16.0	195	38 ~ 82	0 ~ 6	36	HDP-16			
3830 ※ 0540000	-225	3.5 ~ 16.0	225	38 ~ 82	0 ~ 6	36	HDP-16			
3830 ※ 0550000	-255	3.5 ~ 16.0	255	38 ~ 82	0 ~ 6	36	HDP-16			
3830 ※ 0560000	NBT-AHO50 or WBT-AHO50 -HDC22A -105	3.5 ~ 22.0	105	47 ~ 67	0 ~ 8	46	HDP-22	3.4	FDC-22	S-5L
3830 ※ 0570000	-120	3.5 ~ 22.0	120	47 ~ 82	0 ~ 8	46	HDP-22			
3830 ※ 0580000	-135	3.5 ~ 22.0	135	47 ~ 97	0 ~ 8	46	HDP-22			
3830 ※ 0590000	-150	3.5 ~ 22.0	150	47 ~ 103	0 ~ 8	46	HDP-22			
3830 ※ 0600000	-165	3.5 ~ 22.0	165	47 ~ 103	0 ~ 8	46	HDP-22			
3830 ※ 0610000	-195	3.5 ~ 22.0	195	47 ~ 103	0 ~ 8	46	HDP-22			
3830 ※ 0620000	-225	3.5 ~ 22.0	225	47 ~ 103	0 ~ 8	46	HDP-22			
3830 ※ 0630000	-255	3.5 ~ 22.0	255	47 ~ 103	0 ~ 8	46	HDP-22			

Favor de reemplazar ※ en el código con 1 para el NBT-AHO y con 6 para el WBT-AHO.

- La boquilla, el tornillo de preajuste y la llave inglesa se venden por separado. El tornillo estándar de preajuste está incluido.
- Consulte la pág. 096 para conocer la longitud mínima para insertar herramientas en caso de usar nuestras boquillas refrigerantes (OH, C o MS).
- ℓ indica la dimensión cuando se use con un tornillo de preajuste.
- Consulte la pág. 521 para conocer el Torque estándar de apriete.

Please replace ※ in the code with 1 for NBT-AHO and 6 for WBT-AHO.

- Collet, spanner, and preset screw for semi-dry processing are sold separately. Standard preset screw is included.
- Refer to P. 096 for minimum tool insertion length in case of using our coolant collets (OH, C or MS).
- ℓ indicates dimension when using with a preset screw.
- See P. 521 for standard Tightening Torque.

Ejemplo para Ordenar - Ordering Example

Correspondiente a nuestro zanco con contacto de doble cara BT
Corresponding to our two-face contact BT spindle

NBT-AHO30 - HDC 12 A - 90
 Interfaz y diámetro de husillo / Shank size
 Máx. Diámetro Interno de boquilla / Max. collet I.D.
 Longitud de proyección / Projection length (L)

Ejemplo para Ordenar - Ordering Example

Correspondiente al zanco con contacto de doble cara BT
Corresponding to BT two-face contact spindle

WBT-AHO30 - HDC 12 A - 90
 Interfaz y diámetro de husillo / Shank size
 Máx. Diámetro Interno de boquilla / Max. collet I.D.
 Longitud de proyección / Projection length (L)

Boquilla Collet Pág. 090-093	Llave inglesa Spanner Pág. 99	Tornillo de preajuste Preset screw Pág. 098
		

Drill Holder With Easy Tool Length Adjustment

- La longitud de proyección de la herramienta de corte se puede ajustar simplemente girando la circunferencia del portaherramienta.
- Projection length of the cutting tool can be adjusted by simply turning circumference of the holder.

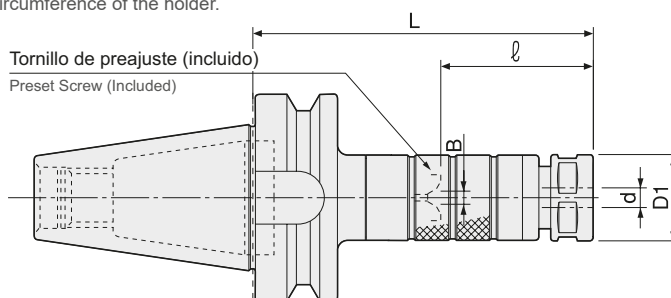

- Nuestro portaherramientas NBT de doble contacto es incompatible con el portaherramientas BT de doble contacto (para WBT-AHO). Por favor consultar pág. 50
- Cuando el modelo "AHO" es utilizado con alimentación de refrigerante que pasa a través del centro del portaherramienta, debe utilizarse un tornillo de retención diseñado para AHO (con pipa de refrigerante).
- Our two-face contact NBT spindle is incompatible with BT two-face contact spindle (for WBT-AHO). Please refer to p.50
- When AHO is used with center through coolant feeding, a designated retention stud (with coolant pipe) for AHO must be used.

Unidad : Métrico
Unit : Metric

Código Code	Modelo Model	d	L	ℓ	B	D1	Tuerca ciega Nut	Boquilla Collet	Llave inglesa Spanner
3750 ※ 0010000	NBT-AHO30 or WBT-AHO30 -SDM07 -75	0.5 ~ 7.0	75	29 ~ 39	0 ~ 4	23	HDP-07A		
3750 ※ 0020000	-90	0.5 ~ 7.0	90	29 ~ 54	0 ~ 4	23	HDP-07A	FDC-07	S-0
3750 ※ 0030000	-105	0.5 ~ 7.0	105	29 ~ 54	0 ~ 4	23	HDP-07A		
3750 ※ 0040000	-120	0.5 ~ 7.0	120	29 ~ 54	0 ~ 4	23	HDP-07A		
3750 ※ 0050000	-135	0.5 ~ 7.0	135	29 ~ 54	0 ~ 4	23	HDP-07A		
3750 ※ 0060000	-150	0.5 ~ 7.0	150	29 ~ 54	0 ~ 4	23	HDP-07A		
3750 ※ 0070000	NBT-AHO30 or WBT-AHO30 -SDM09 -90	2.5 ~ 9.0	90	28 ~ 38	0 ~ 4	26	HDP-09	FDC-09	S-1L
3750 ※ 0080000	-105	2.5 ~ 9.0	105	28 ~ 53	0 ~ 4	26	HDP-09		
3750 ※ 0090000	-120	2.5 ~ 9.0	120	28 ~ 53	0 ~ 4	26	HDP-09		
3750 ※ 0100000	-135	2.5 ~ 9.0	135	28 ~ 53	0 ~ 4	26	HDP-09		
3750 ※ 0110000	-150	2.5 ~ 9.0	150	28 ~ 53	0 ~ 4	26	HDP-09		
3750 ※ 0120000	-165	2.5 ~ 9.0	165	28 ~ 53	0 ~ 4	26	HDP-09		
3750 ※ 0130000	NBT-AHO30 or WBT-AHO30 -SDM12 -90	2.5 ~ 12.0	90	34 ~ 44	0 ~ 5	32	HDP-12	FDC-12	S-3L
3750 ※ 0140000	-105	2.5 ~ 12.0	105	34 ~ 59	0 ~ 5	32	HDP-12		
3750 ※ 0150000	-120	2.5 ~ 12.0	120	34 ~ 59	0 ~ 5	32	HDP-12		
3750 ※ 0160000	-135	2.5 ~ 12.0	135	34 ~ 59	0 ~ 5	32	HDP-12		
3750 ※ 0170000	-150	2.5 ~ 12.0	150	34 ~ 59	0 ~ 5	32	HDP-12		
3750 ※ 0180000	-165	2.5 ~ 12.0	165	34 ~ 59	0 ~ 5	32	HDP-12		
3750 ※ 0190000	NBT-AHO30 or WBT-AHO30 -SDM16 -105	3.5 ~ 16.0	105	40 ~ 50	0 ~ 6	36	HDP-16	FDC-16	S-4L
3750 ※ 0200000	-120	3.5 ~ 16.0	120	40 ~ 65	0 ~ 6	36	HDP-16		
3750 ※ 0210000	-135	3.5 ~ 16.0	135	40 ~ 65	0 ~ 6	36	HDP-16		
3750 ※ 0220000	-150	3.5 ~ 16.0	150	40 ~ 65	0 ~ 6	36	HDP-16		
3750 ※ 0230000	-165	3.5 ~ 16.0	165	40 ~ 65	0 ~ 6	36	HDP-16		
3750 ※ 0240000	NBT-AHO30 or WBT-AHO30 -SDM22 -105	3.5 ~ 22.0	105	48 ~ 58	0 ~ 8	46	HDP-22	FDC-22	S-5L
3750 ※ 0250000	-120	3.5 ~ 22.0	120	48 ~ 73	0 ~ 8	46	HDP-22		
3750 ※ 0260000	-135	3.5 ~ 22.0	135	48 ~ 73	0 ~ 8	46	HDP-22		
3750 ※ 0270000	-150	3.5 ~ 22.0	150	48 ~ 73	0 ~ 8	46	HDP-22		
3750 ※ 0280000	-165	3.5 ~ 22.0	165	48 ~ 73	0 ~ 8	46	HDP-22		
3750 ※ 0290000	NBT-AHO40 or WBT-AHO40 -SDM07 -90	0.5 ~ 7.0	90	29 ~ 39	0 ~ 4	23	HDP-07A	FDC-07	S-0
3750 ※ 0300000	-105	0.5 ~ 7.0	105	29 ~ 54	0 ~ 4	23	HDP-07A		
3750 ※ 0310000	-120	0.5 ~ 7.0	120	29 ~ 54	0 ~ 4	23	HDP-07A		
3750 ※ 0320000	-135	0.5 ~ 7.0	135	29 ~ 54	0 ~ 4	23	HDP-07A		
3750 ※ 0330000	-150	0.5 ~ 7.0	150	29 ~ 54	0 ~ 4	23	HDP-07A		
3750 ※ 0340000	NBT-AHO40 or WBT-AHO40 -SDM09 -90	2.5 ~ 9.0	90	28 ~ 38	0 ~ 4	26	HDP-09	FDC-09	S-1L
3750 ※ 0350000	-105	2.5 ~ 9.0	105	28 ~ 53	0 ~ 4	26	HDP-09		
3750 ※ 0360000	-120	2.5 ~ 9.0	120	28 ~ 53	0 ~ 4	26	HDP-09		
3750 ※ 0370000	-135	2.5 ~ 9.0	135	28 ~ 53	0 ~ 4	26	HDP-09		
3750 ※ 0380000	-150	2.5 ~ 9.0	150	28 ~ 53	0 ~ 4	26	HDP-09		
3750 ※ 0390000	-180	2.5 ~ 9.0	180	28 ~ 53	0 ~ 4	26	HDP-09		

Código Code	Modelo Model	d	L	ℓ	B	D1	Tuerca ciega Nut	Boquilla Collet	Llave inglesa Spanner
3750 * 0400000	NBT-AHO40 or WBT-AHO40 -SDM12 -90	2.5 ~ 12.0	90	34 ~ 44	0 ~ 5	32	HDP-12	FDC-12	S-3L
3750 * 0410000	-105	2.5 ~ 12.0	105	34 ~ 59	0 ~ 5	32	HDP-12		
3750 * 0420000	-120	2.5 ~ 12.0	120	34 ~ 59	0 ~ 5	32	HDP-12		
3750 * 0430000	-135	2.5 ~ 12.0	135	34 ~ 59	0 ~ 5	32	HDP-12		
3750 * 0440000	-150	2.5 ~ 12.0	150	34 ~ 59	0 ~ 5	32	HDP-12		
3750 * 0450000	-180	2.5 ~ 12.0	180	34 ~ 59	0 ~ 5	32	HDP-12		
3750 * 0460000	NBT-AHO40 or WBT-AHO40 -SDM16 -105	3.5 ~ 16.0	105	40 ~ 50	0 ~ 6	36	HDP-16	FDC-16	S-4L
3750 * 0470000	-120	3.5 ~ 16.0	120	40 ~ 65	0 ~ 6	36	HDP-16		
3750 * 0480000	-135	3.5 ~ 16.0	135	40 ~ 65	0 ~ 6	36	HDP-16		
3750 * 0490000	-150	3.5 ~ 16.0	150	40 ~ 65	0 ~ 6	36	HDP-16		
3750 * 0500000	-180	3.5 ~ 16.0	180	40 ~ 65	0 ~ 6	36	HDP-16		
3750 * 0510000	NBT-AHO40 or WBT-AHO40 -SDM22 -120	3.5 ~ 22.0	120	48 ~ 58	0 ~ 8	46	HDP-22		
3750 * 0520000	-135	3.5 ~ 22.0	135	48 ~ 73	0 ~ 8	46	HDP-22		
3750 * 0530000	-150	3.5 ~ 22.0	150	48 ~ 73	0 ~ 8	46	HDP-22		
3750 * 0540000	-180	3.5 ~ 22.0	180	48 ~ 73	0 ~ 8	46	HDP-22		
3750 * 0550000	NBT-AHO50 or WBT-AHO50 -SDM07 -90	0.5 ~ 7.0	90	29 ~ 39	0 ~ 4	23	HDP-07A	FDC-07	S-0
3750 * 0560000	-105	0.5 ~ 7.0	105	29 ~ 54	0 ~ 4	23	HDP-07A		
3750 * 0570000	-120	0.5 ~ 7.0	120	29 ~ 54	0 ~ 4	23	HDP-07A		
3750 * 0580000	-135	0.5 ~ 7.0	135	29 ~ 54	0 ~ 4	23	HDP-07A		
3750 * 0590000	-150	0.5 ~ 7.0	150	29 ~ 54	0 ~ 4	23	HDP-07A		
3750 * 0600000	-165	0.5 ~ 7.0	165	29 ~ 54	0 ~ 4	23	HDP-07A		
3750 * 0610000	NBT-AHO50 or WBT-AHO50 -SDM09 -90	2.5 ~ 9.0	90	28 ~ 38	0 ~ 4	26	HDP-09	FDC-09	S-1L
3750 * 0620000	-105	2.5 ~ 9.0	105	28 ~ 53	0 ~ 4	26	HDP-09		
3750 * 0630000	-120	2.5 ~ 9.0	120	28 ~ 53	0 ~ 4	26	HDP-09		
3750 * 0640000	-135	2.5 ~ 9.0	135	28 ~ 53	0 ~ 4	26	HDP-09		
3750 * 0650000	-150	2.5 ~ 9.0	150	28 ~ 53	0 ~ 4	26	HDP-09		
3750 * 0660000	-180	2.5 ~ 9.0	180	28 ~ 53	0 ~ 4	26	HDP-09		
3750 * 0670000	NBT-AHO50 or WBT-AHO50 -SDM12 -105	2.5 ~ 12.0	105	34 ~ 44	0 ~ 5	32	HDP-12	FDC-12	S-3L
3750 * 0680000	-120	2.5 ~ 12.0	120	34 ~ 59	0 ~ 5	32	HDP-12		
3750 * 0690000	-135	2.5 ~ 12.0	135	34 ~ 59	0 ~ 5	32	HDP-12		
3750 * 0700000	-150	2.5 ~ 12.0	150	34 ~ 59	0 ~ 5	32	HDP-12		
3750 * 0710000	-180	2.5 ~ 12.0	180	34 ~ 59	0 ~ 5	32	HDP-12		
3750 * 0720000	NBT-AHO50 or WBT-AHO50 -SDM16 -105	3.5 ~ 16.0	105	40 ~ 50	0 ~ 6	36	HDP-16		
3750 * 0730000	-120	3.5 ~ 16.0	120	40 ~ 65	0 ~ 6	36	HDP-16		
3750 * 0740000	-135	3.5 ~ 16.0	135	40 ~ 65	0 ~ 6	36	HDP-16		
3750 * 0750000	-150	3.5 ~ 16.0	150	40 ~ 65	0 ~ 6	36	HDP-16		
3750 * 0760000	-180	3.5 ~ 16.0	180	40 ~ 65	0 ~ 6	36	HDP-16		
3750 * 0770000	NBT-AHO50 or WBT-AHO50 -SDM22 -120	3.5 ~ 22.0	120	48 ~ 58	0 ~ 8	46	HDP-22	FDC-22	S-5L
3750 * 0780000	-135	3.5 ~ 22.0	135	48 ~ 73	0 ~ 8	46	HDP-22		
3750 * 0790000	-150	3.5 ~ 22.0	150	48 ~ 73	0 ~ 8	46	HDP-22		
3750 * 0800000	-180	3.5 ~ 22.0	180	48 ~ 73	0 ~ 8	46	HDP-22		
3750 * 0810000	-210	3.5 ~ 22.0	210	48 ~ 73	0 ~ 8	46	HDP-22		

Favor de reemplazar * en el código con Ø para el NBT-AHO y con 6 para el WBT-AHO.

1. La boquilla y la llave inglesa se venden por separado.
2. ℓ es la dimensión entre el cabezal del pistón y el extremo superior del tornillo de pre-ajuste.
3. Consulte la pág. 520 para conocer el Torque estándar de apriete.

Please replace * in the code with Ø for NBT-AHO and 6 for WBT-AHO.

1. Collet and spanner are sold separately.
2. ℓ is the dimension between the cap end and the preset screw top end.
3. See P.520 for standard Tightening Torque.

Ejemplo para Ordenar - Ordering Example

Correspondiente a nuestro zanco con contacto de doble cara BT
Corresponding to our two-face contact BT spindle

NBT-AHO40 - SDM 12 - 90
Interfaz y diámetro de husillo Shank size
Máx. Diámetro Interno de boquilla Max. collet I.D.
Longitud de proyección Projection length (L)

Ejemplo para Ordenar - Ordering Example

Correspondiente al zanco con contacto de doble cara BT
Corresponding to BT two-face contact spindle

WBT-AHO40 - SDM 12 - 90
Interfaz y diámetro de husillo Shank size
Máx. Diámetro Interno de boquilla Max. collet I.D.
Longitud de proyección Projection length (L)

Boquilla Collet
Pág. 090-093



Llave Inglesa Spanner
Pág. 099



"R" Zero Holder

● La precisión de excentricidad del borde de corte puede ajustarse hasta casi cero (del tipo con alto balance).

● Runout accuracy of the cutting edge can be adjusted as closely as to zero.

Tipo1
Type1

Tornillo de preajuste (Incluido)

Preset Screw (Included)

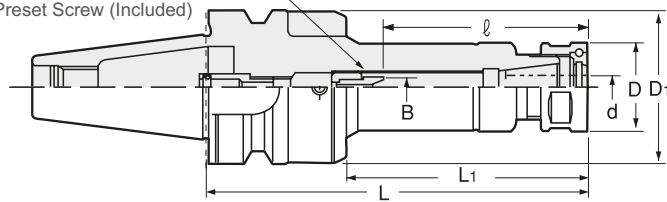

Tipo2
Type2

Tornillo de preajuste (Incluido)

Preset Screw (Included)

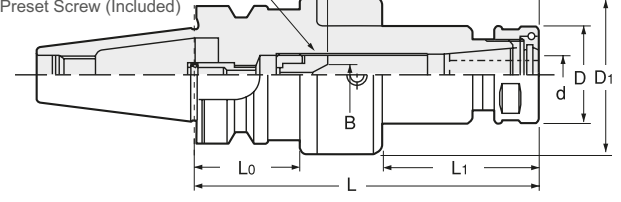

• Nuestro portaherramientas NBT de doble contacto es incompatible con el portaherramientas BT de doble contacto (para WBT-AHO). Por favor consultar pág. 50

• Cuando el modelo "AHO" es utilizado con alimentación de refrigerante que pasa a través del centro del portaherramienta, debe utilizarse un tornillo de retención diseñado para AHO (con pipa de refrigerante).

• Our two-face contact NBT spindle is incompatible with BT two-face contact spindle (for WBT-AHO). Please refer to p.50

• When AHO is used with center through coolant feeding, a designated retention stud (with coolant pipe) for AHO must be used.

Unidad : Métrico
Unit : Metric

Código Code	Modelo Model	Tipo Type	d	L	L1	ℓ	B	D1	D	L0	Tuerca ciega Nut	kg	Boquilla Collet	Llave Inglesa Spanner
3840 ※ 0640000	NBT-AHO30 or WBT-AHO30 -HDZ07 -60	1	0.5 ~ 7.0	60	22	22 ~ 23	0 ~ 4	41	23	—	HDP-07A			
3840 ※ 0650000	-75	1	0.5 ~ 7.0	75	37	22 ~ 38	0 ~ 4	41	23	—	HDP-07A		FDC-07	S-0
3840 ※ 0660000	-90	1	0.5 ~ 7.0	90	52	22 ~ 45	0 ~ 4	41	23	—	HDP-07A			
3840 ※ 0670000	-105	1	0.5 ~ 7.0	105	67	22 ~ 45	0 ~ 4	41	23	—	HDP-07A			
3840 ※ 0680000	NBT-AHO30 or WBT-AHO30 -HDZ09 -75	1	2.5 ~ 9.0	75	37	27 ~ 40	0 ~ 4	45	26	—	HDP-09		FDC-09	S-1L
3840 ※ 0690000	-90	1	2.5 ~ 9.0	90	52	27 ~ 50	0 ~ 4	45	26	—	HDP-09			
3840 ※ 0700000	-105	1	2.5 ~ 9.0	105	67	27 ~ 57	0 ~ 4	45	26	—	HDP-09			
3840 ※ 0760000	-120	1	2.5 ~ 9.0	120	82	27 ~ 57	0 ~ 4	45	26	—	HDP-09			
3840 ※ 0710000	NBT-AHO30 or WBT-AHO30 -HDZ12 -90	2	2.5 ~ 12.0	90	33	33 ~ 55	0 ~ 5	52	32	32	HDP-12		FDC-12	S-3L
3840 ※ 0720000	-105	2	2.5 ~ 12.0	105	48	33 ~ 65	0 ~ 5	52	32	32	HDP-12			
3840 ※ 0770000	-120	2	2.5 ~ 12.0	120	63	33 ~ 69	0 ~ 5	52	32	32	HDP-12			
3840 ※ 0730000	NBT-AHO30 or WBT-AHO30 -HDZ16 -90	2	3.5 ~ 16.0	90	33	38 ~ 50	0 ~ 6	56	36	32	HDP-16		FDC-16	S-4L
3840 ※ 0740000	-105	2	3.5 ~ 16.0	105	48	38 ~ 65	0 ~ 6	56	36	32	HDP-16			
3840 ※ 0750000	-120	2	3.5 ~ 16.0	120	63	38 ~ 80	0 ~ 6	56	36	32	HDP-16			
3840 ※ 0010000	NBT-AHO40 or WBT-AHO40 -HDZ07 -75	1	0.5 ~ 7.0	75	32	22 ~ 38	0 ~ 4	41	23	—	HDP-07A		FDC-07	S-0
3840 ※ 0020000	-90	1	0.5 ~ 7.0	90	47	22 ~ 45	0 ~ 4	41	23	—	HDP-07A			
3840 ※ 0030000	-105	1	0.5 ~ 7.0	105	62	22 ~ 45	0 ~ 4	41	23	—	HDP-07A			
3840 ※ 0780000	-120	1	0.5 ~ 7.0	120	77	22 ~ 45	0 ~ 4	41	23	—	HDP-07A			
3840 ※ 0790000	-135	1	0.5 ~ 7.0	135	92	22 ~ 45	0 ~ 4	41	23	—	HDP-07A			
3840 ※ 0040000	NBT-AHO40 or WBT-AHO40 -HDZ09 -90	1	2.5 ~ 9.0	90	47	27 ~ 55	0 ~ 4	45	26	—	HDP-09		FDC-09	S-1L
3840 ※ 0050000	-105	1	2.5 ~ 9.0	105	62	27 ~ 57	0 ~ 4	45	26	—	HDP-09			
3840 ※ 0060000	-120	1	2.5 ~ 9.0	120	77	27 ~ 57	0 ~ 4	45	26	—	HDP-09			
3840 ※ 0070000	-135	1	2.5 ~ 9.0	135	92	27 ~ 57	0 ~ 4	45	26	—	HDP-09			
3840 ※ 0080000	-165	1	2.5 ~ 9.0	165	122	27 ~ 57	0 ~ 4	45	26	—	HDP-09			
3840 ※ 0090000	NBT-AHO40 or WBT-AHO40 -HDZ12 -90	1	2.5 ~ 12.0	90	43	33 ~ 55	0 ~ 5	56	32	—	HDP-12		FDC-12	S-3L
3840 ※ 0100000	-105	1	2.5 ~ 12.0	105	58	33 ~ 69	0 ~ 5	56	32	—	HDP-12			
3840 ※ 0110000	-120	1	2.5 ~ 12.0	120	73	33 ~ 69	0 ~ 5	56	32	—	HDP-12			
3840 ※ 0120000	-135	1	2.5 ~ 12.0	135	88	33 ~ 69	0 ~ 5	56	32	—	HDP-12			
3840 ※ 0130000	-165	1	2.5 ~ 12.0	165	118	33 ~ 69	0 ~ 5	56	32	—	HDP-12			
3840 ※ 0140000	-195	1	2.5 ~ 12.0	195	148	33 ~ 69	0 ~ 5	56	32	—	HDP-12			
3840 ※ 0150000	NBT-AHO40 or WBT-AHO40 -HDZ16 -90	1	3.5 ~ 16.0	90	43	38 ~ 55	0 ~ 6	62	36	—	HDP-16	1.4	FDC-16	S-4L
3840 ※ 0160000	-105	1	3.5 ~ 16.0	105	58	38 ~ 70	0 ~ 6	62	36	—	HDP-16			
3840 ※ 0170000	-120	1	3.5 ~ 16.0	120	73	38 ~ 82	0 ~ 6	62	36	—	HDP-16			
3840 ※ 0180000	-135	1	3.5 ~ 16.0	135	88	38 ~ 82	0 ~ 6	62	36	—	HDP-16			
3840 ※ 0190000	-165	1	3.5 ~ 16.0	165	118	38 ~ 82	0 ~ 6	62	36	—	HDP-16			
3840 ※ 0200000	-195	1	3.5 ~ 16.0	195	148	38 ~ 82	0 ~ 6	62	36	—	HDP-16			





Código Code	Modelo Model	Tipo Type	d	L	L1	ℓ	B	D1	D	L0	Tuerca ciega Nut	kg	Boquilla Collet	Llave Inglesa Spanner
3840 ※ 1210000	NBT-AHO40 or WBT-AHO40	-HDZ22-A-105	2	3.5 ~ 22.0	105	31	47 ~ 65	0 ~ 8	69	46	45		FDC-22	S-5L
3840 ※ 1220000		-120	2	3.5 ~ 22.0	120	46	47 ~ 80	0 ~ 8	69	46	45			
3840 ※ 1230000		-135	2	3.5 ~ 22.0	135	61	47 ~ 95	0 ~ 8	69	46	45	2.3		
3840 ※ 1240000		-165	2	3.5 ~ 22.0	165	91	47 ~ 103	0 ~ 8	69	46	45			
3840 ※ 1250000		-195	2	3.5 ~ 22.0	195	121	47 ~ 103	0 ~ 8	69	46	45			
3840 ※ 0260000	NBT-AHO50 or WBT-AHO50	-HDZ07 -90	1	0.5 ~ 7.0	90	36	22 ~ 45	0 ~ 4	41	23	-		FDC-07	S-0
3840 ※ 0270000		-105	1	0.5 ~ 7.0	105	51	22 ~ 45	0 ~ 4	41	23	-			
3840 ※ 0280000		-120	1	0.5 ~ 7.0	120	66	22 ~ 45	0 ~ 4	41	23	-			
3840 ※ 0290000		-135	1	0.5 ~ 7.0	135	81	22 ~ 45	0 ~ 4	41	23	-			
3840 ※ 0300000		-165	1	0.5 ~ 7.0	165	111	22 ~ 45	0 ~ 4	41	23	-			
3840 ※ 0310000		-195	1	0.5 ~ 7.0	195	141	22 ~ 45	0 ~ 4	41	23	-			
3840 ※ 0320000	NBT-AHO50 or WBT-AHO50	-HDZ09 -90	1	2.5 ~ 9.0	90	36	27 ~ 50	0 ~ 4	45	26	-		FDC-09	S-1L
3840 ※ 0330000		-105	1	2.5 ~ 9.0	105	51	27 ~ 57	0 ~ 4	45	26	-			
3840 ※ 0340000		-120	1	2.5 ~ 9.0	120	66	27 ~ 57	0 ~ 4	45	26	-			
3840 ※ 0350000		-135	1	2.5 ~ 9.0	135	81	27 ~ 57	0 ~ 4	45	26	-			
3840 ※ 0360000		-165	1	2.5 ~ 9.0	165	111	27 ~ 57	0 ~ 4	45	26	-			
3840 ※ 0370000		-195	1	2.5 ~ 9.0	195	141	27 ~ 57	0 ~ 4	45	26	-			
3840 ※ 0380000		-225	1	2.5 ~ 9.0	225	171	27 ~ 57	0 ~ 4	45	26	-			
3840 ※ 0390000		-255	1	2.5 ~ 9.0	255	201	27 ~ 57	0 ~ 4	45	26	-			
3840 ※ 0400000	NBT-AHO50 or WBT-AHO50	-HDZ12 -90	1	2.5 ~ 12.0	90	32	33 ~ 50	0 ~ 5	56	32	-			
3840 ※ 0410000		-105	1	2.5 ~ 12.0	105	47	33 ~ 65	0 ~ 5	56	32	-			
3840 ※ 0420000		-120	1	2.5 ~ 12.0	120	62	33 ~ 69	0 ~ 5	56	32	-			
3840 ※ 0430000		-135	1	2.5 ~ 12.0	135	77	33 ~ 69	0 ~ 5	56	32	-			
3840 ※ 0440000		-165	1	2.5 ~ 12.0	165	107	33 ~ 69	0 ~ 5	56	32	-			
3840 ※ 0450000		-195	1	2.5 ~ 12.0	195	137	33 ~ 69	0 ~ 5	56	32	-			
3840 ※ 0460000		-225	1	2.5 ~ 12.0	225	167	33 ~ 69	0 ~ 5	56	32	-			
3840 ※ 0470000		-255	1	2.5 ~ 12.0	255	197	33 ~ 69	0 ~ 5	56	32	-			
3840 ※ 0480000	NBT-AHO50 or WBT-AHO50	-HDZ16 -90	1	3.5 ~ 16.0	90	32	38 ~ 50	0 ~ 6	62	36	-		FDC-16	S-4L
3840 ※ 0490000		-105	1	3.5 ~ 16.0	105	47	38 ~ 65	0 ~ 6	62	36	-			
3840 ※ 0500000		-120	1	3.5 ~ 16.0	120	62	38 ~ 82	0 ~ 6	62	36	-			
3840 ※ 0510000		-135	1	3.5 ~ 16.0	135	77	38 ~ 82	0 ~ 6	62	36	-			
3840 ※ 0520000		-165	1	3.5 ~ 16.0	165	107	38 ~ 82	0 ~ 6	62	36	-			
3840 ※ 0530000		-195	1	3.5 ~ 16.0	195	137	38 ~ 82	0 ~ 6	62	36	-			
3840 ※ 0540000		-225	1	3.5 ~ 16.0	225	167	38 ~ 82	0 ~ 6	62	36	-			
3840 ※ 0550000		-255	1	3.5 ~ 16.0	255	197	38 ~ 82	0 ~ 6	62	36	-			
3840 ※ 1560000	NBT-AHO50 or WBT-AHO50	-HDZ22-A-105	1	3.5 ~ 22.0	105	43	47 ~ 67	0 ~ 8	76	46	-			
3840 ※ 1570000		-120	1	3.5 ~ 22.0	120	58	47 ~ 82	0 ~ 8	76	46	-			
3840 ※ 1580000		-135	1	3.5 ~ 22.0	135	73	47 ~ 97	0 ~ 8	76	46	-			
3840 ※ 1590000		-150	1	3.5 ~ 22.0	150	88	47 ~ 103	0 ~ 8	76	46	-			
3840 ※ 1600000		-165	1	3.5 ~ 22.0	165	103	47 ~ 103	0 ~ 8	76	46	-	4.4		
3840 ※ 1610000		-195	1	3.5 ~ 22.0	195	133	47 ~ 103	0 ~ 8	76	46	-			
3840 ※ 1620000		-225	1	3.5 ~ 22.0	225	163	47 ~ 103	0 ~ 8	76	46	-			
3840 ※ 1630000		-255	1	3.5 ~ 22.0	255	193	47 ~ 103	0 ~ 8	76	46	-			

Favor de reemplazar ※ en el código con Ø para el NBT-AHO y con 6 para el WBT-AHO.

1. La boquilla, el tornillo Allen opresor de preajuste y la llave inglesa se venden por separado. El tornillo estándar de preajuste está incluido. El tornillo estándar de preajuste está incluido.
2. Consulte la pág. 096 para conocer la longitud mínima para insertar herramientas en caso de usar nuestras boquillas refrigerantes (OH, C o MS).
3. ℓ indica la dimensión cuando se use con un tornillo de preajuste.
4. Consulte la pág. 521 para conocer el Torque recomendado para nuestros productos.

Please replace ※ in the code with Ø for NBT-AHO and 6 for WBT-AHO.

1. Collet, spanner, hexagon head preset screw, preset screw for semi-dry processing, and adjustment wrench are sold separately. Standard preset screw is included.
2. Refer to P.096 for minimum tool insertion length in case of using our coolant collets (OH, C or MS).
3. ℓ indicates dimension when using with a preset screw.
4. See P.521 for standard Tightening Torque.

Boquilla Collet	Llave de Torque Spanner	Tuerca de preajuste Preset screw	Llave Allen Adjustment wrench
Pág. 090-093	Pág. 099	Pág. 098	Pág. 099
			

Ejemplo para Ordenar - Ordering Example

Correspondiente a nuestro zanco con contacto de doble cara BT
Corresponding to our two-face contact BT spindle

NBT-AHO40	- HDZ	12	-	90
Interfaz y diámetro de husillo		Máx. Diámetro Interno de boquilla		Longitud de proyección
Shank size		Max. collet I.D.		Projection length (L)

Ejemplo para Ordenar - Ordering Example

Correspondiente al zanco con contacto de doble cara BT
Corresponding to BT two-face contact spindle

WBT-AHO40	- HDZ	12	-	90
Interfaz y diámetro de husillo		Máx. Diámetro Interno de boquilla		Longitud de proyección
Shank size		Max. collet I.D.		Projection length (L)

CTZ-SA

"R" Zero Holder for Large Diameter

- La excentricidad del borde de corte se puede ajustar hasta casi cero. Es adecuado para rima con diámetro amplio.
- Runout of the cutting edge can be adjusted as close as to zero. Suitable for large diameter reaming.

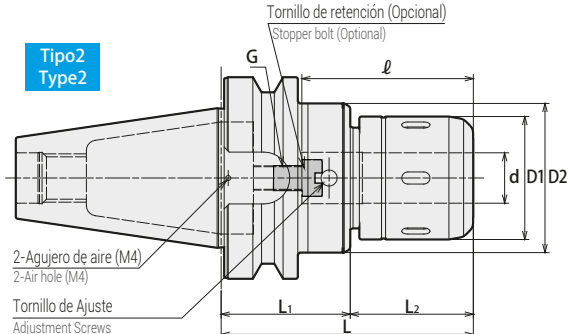
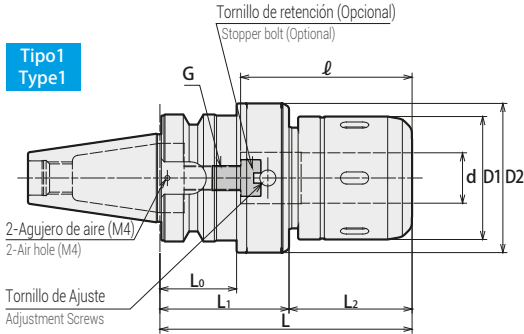

⚠ Precaución/ Caution

- ★ :Tenga precaución con la interferencia del brazo A.T.C. (automatic tool changer) y el cartucho. Take caution against A.T.C. arm and tool magazine interference.

Precaución/ Caution

- Favor de girar el anillo de sujeción en sentido contrario a las manecillas del reloj por más de 360 grados después de quitar una herramienta de corte. Please rotate the clamping ring counterclockwise more than 360 degrees after a cutting tool is removed.



- Nuestro portaherramientas NBT de doble contacto es incompatible con el portaherramientas BT de doble contacto (para WBT-AHO). Por favor consultar pág. 50
- Cuando el modelo "AHO" es utilizado con alimentación de refrigerante que pasa a través del centro del portaherramienta, debe utilizarse un tornillo de retención diseñado para AHO (con pipa de refrigerante).
- Our two-face contact NBT spindle is incompatible with BT two-face contact spindle (for WBT-AHO). Please refer to p.50
- When AHO is used with center through coolant feeding, a designated retention stud (with coolant pipe) for AHO must be used.

Medidas Métricas - Metric Sizes

Unidad : Métrico
Unit : Metric

Código Code	Modelo Model	Tipo Type	d	L	L1	L2	D1	D2	L0	ℓ	G P=1.0	kg	-	Tornillo de Retención Stopper Bolt	Llave de Torque Spanner	Llave Allen Hex.Wrench
3730 ※ 0030100	NBT-AHO40 or WBT-AHO40 -CTZ25SA -125	1	25	125	64	61	61	74	★ 38	80	12	2.8	57,500	BL20- ※※	HS-2.5-25	L-6L (Incluida / Included)
3730 ※ 0040100	-150	1	25	150	74	76	61	74	48	80	12	3.2	58,000	Inutilizable / unusable	HS-3-32	
3730 ※ 0050100	-CTZ32SA -125 ※ 1	1	32	125	64	61	68	80	★ 35	95	18	3.0	59,000			
3730 ※ 0060100	-150	1	32	150	74	76	68	80	45	120	18	3.3	61,000			
3730 ※ 0090100	NBT-AHO50 or WBT-AHO50 -CTZ25SA -125	2	25	125	64	61	61	74	-	80	12	4.6	67,500	BL20- ※※	HS-2.5-25	
3730 ※ 0101000	-165	2	25	165	64	101	61	74	-	80	12	5.1	68,000	Inutilizable / unusable	HS-3-32	
3730 ※ 0110100	-CTZ32SA -125 ※ 2	2	32	125	64	61	68	80	-	105	-	4.6	73,000			
3730 ※ 0120100	-165	2	32	165	64	101	68	80	-	120	18	5.0	75,000			
3730 ※ 0130100	-CTZ42SA -125 ※ 3	2	42	125	64	61	88	99	-	105	-	5.7	80,000	Inutilizable / unusable	HS-4-42	
3730 ※ 0140100	-165 ※ 4	2	42	165	64	101	88	99	-	120	18	6.8	84,000	BL32- ※※		

Favor de reemplazar ※ en el código con Ø para el NBT-AHO y con 6 para el WBT-AHO.





1. Al hacer su orden, indique el número de llaves inglesas que requiere. Las llaves inglesas "son gratuitas" y están limitadas al número de portaherramientas de fresado de su orden.
2. Incluye una llave Allen.
3. El modelo con " * 1- * 3" no es compatible con algunos accesorios. Para obtener más información sobre los accesorios, diríjase a la tabla a continuación.
4. Nuestro portaherramientas BT de doble contacto (para NBT-AHO) no es compatible con el portaherramientas BT de doble contacto (para WBT-AHO).
5. La tolerancia del zanco de la herramienta de corte debe ser h7.

Please replace ※ in the code with Ø for NBT-AHO and 6 for WBT-AHO.

1. When ordering, indicate number of spanners required. "No charge" spanners are limited to number of holders on order.
2. A wrench is included.
3. The model with " * 1- * 4" is not compatible with some accessories. For more information about the accessories, please refer below chart.
4. NT's two-face contact BT spindle (for NBT-AHO) and BT two-face contact spindle (for WBT-AHO) are not compatible.
5. Tolerance of cutting tool shank must be h7.

Accesorios Accessories

Los modelos con * 1- * 3 no se pueden usar con algunos accesorios debido a su corta longitud ℓ.
Models with * 1 - * 4 cannot be used with some accessories due to short ℓ length.

	Tornillo de Retención Stopper Bolt 	Boquilla recta Straight Collet 		Adaptador de zanco Morse Morse Taper Adapter 		Adaptador Jacobs Jacobs Adapter 	
	BL (Pág.072)	MC (Pág.070)	MCA (Pág.071)	MA (Pág.072)	MAB (Pág.072)	JA (Pág.073)	JAB (Pág.073)
* 1	No	Sí / Yes	No	No	Sí / Yes	No	Sí / Yes
* 2	No	Sí / Yes	No	Sí / Yes	Sí / Yes	Sí / Yes	Sí / Yes
* 3	No	Sí / Yes	No	No	No	No	No
* 4	Sí / Yes	Sí / Yes	No	Sí / Yes	Sí / Yes	Sí / Yes	Sí / Yes

Ejemplo para Ordenar - Ordering Example

Correspondiente a nuestro zanco con contacto de doble cara BT
Corresponding to our two-face contact BT spindle

NBT-AHO40 - CTZ 32 SA - 125

Interfaz y
diámetro de husillo
Shank size

Diámetro
Interno
I.D. (d)

Longitud de
proyección
Projection length (L)

Ejemplo para Ordenar - Ordering Example

Correspondiente al zanco con contacto de doble cara BT
Corresponding to BT two-face contact spindle

WBT-AHO40 - CTZ 32 SA - 125

Interfaz y
diámetro de husillo
Shank size

Diámetro
Interno
I.D. (d)

Longitud de
proyección
Projection length (L)

Longitud mín de inserción Min. chucking length

Fresado directo (sin boquilla MC)
Direct Chucking (without MC Collet)

Diámetro Interno del Portaherramienta I.D. of Chuck	Longitud mín de inserción Min. chucking length
25,32,42	50

Con boquilla MC
With MC collet

D.I. de la boquilla Collet I.D.	Longitud mín de inserción Min. chucking length	
	MC	MC-C, MC-OH
6,8	30	30
10,12	40	40
16,20	45	45
25	50	50
32	50	60

Llave Inglesa
Spanner
Pág. 073



PHC-A



Power Hydro Chuck

- Hydro Chuck con capacidad para el uso de boquillas. Adecuado para cortes de alta precisión.
- Hydro chuck with collet holder flexibility. Suitable for high precision cutting.

Tornillo de retención Para PHC03A & PHC04A, El tornillo de retención no está incluido. Favor de ordenarlo por separado (producto especial).
Stopper bolt For PHC03A & PHC04A, the stopper bolt is not included. Please order separately (Special item).

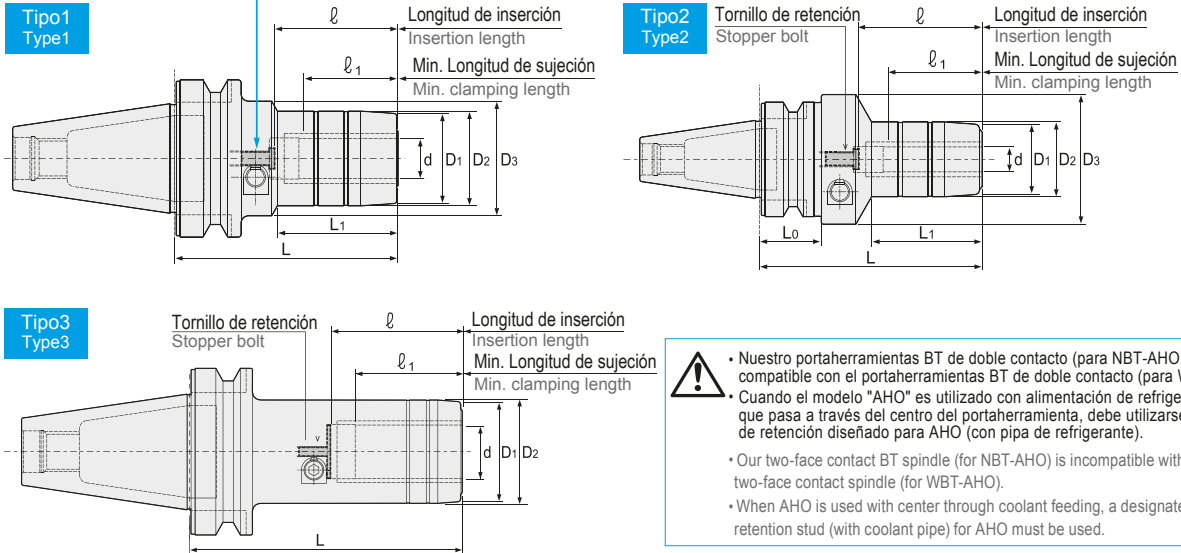

- ⚠ • Nuestro portaherramientas BT de doble contacto (para NBT-AHO) no es compatible con el portaherramientas BT de doble contacto (para WBT-AHO).
- Cuando el modelo "AHO" es utilizado con alimentación de refrigerante que pasa a través del centro del portaherramienta, debe utilizarse un perno de retención diseñado para AHO (con pipa de refrigerante).
- Our two-face contact BT spindle (for NBT-AHO) is incompatible with BT two-face contact spindle (for WBT-AHO).
- When AHO is used with center through coolant feeding, a designated retention stud (with coolant pipe) for AHO must be used.

Medidas Métricas – Metric Sizes

Unidad : Métrico
Unit : Metric

Código Code	Modelo Model	Tipo Type	d	L	L ₁	D ₁	D ₂	D ₃	L ₀	ℓ	ℓ ₁	Kg	Llave Allen (Opcional) Hex. Wrench(Optional)
3970 ※ 0830100	NBT-AHO30 or WBT-AHO30 -PHC03A - 60	1	3	60	19.8	—	24	46	—	27	18	0.6	L-4T (4mm)
3970 ※ 0840100	- 90	1	3	90	44.8	—	24	46	—	49	18	0.7	
3970 ※ 0870100	-PHC04A - 65	1	4	65	25.1	—	25	46	—	29	24	0.6	
3970 ※ 0880100	- 90	1	4	90	45.1	—	25	46	—	49	24	0.7	
3970 ※ 0010100	-PHC06A - 75	1	6	75	30	24	26	46	—	34	29	0.7	
3970 ※ 0020100	-PHC07A - 75	1	7	75	30	26	28	46	—	34	29	0.7	
3970 ※ 0030100	-PHC08A - 75	1	8	75	30	26	28	46	—	34	29	0.7	
3970 ※ 0040100	-PHC09A - 105	2	9	105	44	28	30	52	40	50	40	1.0	
3970 ※ 0050100	-PHC10A - 105	2	10	105	44	28	30	52	40	50	40	1.0	
3970 ※ 0060100	-PHC11A - 105	2	11	105	45	30	32	52	40	50	40	1.1	
3970 ※ 0070100	-PHC12A - 105 *	2	12	105	45	30	32	52	40	50	40	1.1	
3970 ※ 0080100	-PHC13A - 105	2	13	105	46	34	36	52	40	50	40	1.1	
3970 ※ 0090100	-PHC14A - 105	2	14	105	46	34	36	52	40	50	40	1.1	
3970 ※ 0100100	-PHC15A - 105	2	15	105	46	36	38	52	40	50	40	1.1	
3970 ※ 0110100	-PHC16A - 105	2	16	105	46	36	38	52	40	50	40	1.1	
3970 ※ 0120100	-PHC20A - 90 *	1	20	90	49	40	42	46	—	50	40	0.9	
3970 ※ 0130100	- 120 *	1	20	120	69	40	42	46	—	70	40	1.2	
3970 ※ 0850100	NBT-AHO40 or WBT-AHO40 -PHC03A - 65	1	3	65	19.8	—	24	46	—	27	18	1.1	L-4T (4mm)
3970 ※ 0860100	- 90	1	3	90	44.8	—	24	46	—	49	18	1.2	
3970 ※ 0890100	-PHC04A - 70	1	4	70	25.1	—	25	46	—	29	24	1.1	
3970 ※ 0900100	- 90	1	4	90	45.1	—	25	46	—	49	24	1.2	
3970 ※ 0140100	-PHC06A - 75	1	6	75	30	24	26	46	—	34	29	1.1	
3970 ※ 0150100	- 105	1	6	105	41	24	26	46	—	45	29	1.4	
3970 ※ 0160100	-PHC07A - 75	1	7	75	30	26	28	46	—	34	29	1.1	
3970 ※ 0170100	- 105	1	7	105	41	26	28	46	—	45	29	1.4	
3970 ※ 0180100	-PHC08A - 75	1	8	75	30	26	28	46	—	34	29	1.1	
3970 ※ 0190100	- 105	1	8	105	41	26	28	46	—	45	29	1.4	
3970 ※ 0200100	-PHC09A - 90	1	9	90	44	28	30	52	—	50	40	1.3	
3970 ※ 0210100	- 120	1	9	120	64	28	30	52	—	70	40	1.5	
3970 ※ 0220100	-PHC10A - 90	1	10	90	44	28	30	52	—	50	40	1.3	
3970 ※ 0230100	- 120	1	10	120	64	28	30	52	—	70	40	1.5	
3970 ※ 0240100	-PHC11A - 90	1	11	90	45	30	32	52	—	50	40	1.3	
3970 ※ 0250100	- 120	1	11	120	65	30	32	52	—	70	40	1.5	
3970 ※ 0260100	-PHC12A - 90 *	1	12	90	45	30	32	52	—	50	40	1.3	
3970 ※ 0270100	- 120 *	1	12	120	65	30	32	52	—	70	40	1.5	
3970 ※ 0280100	-PHC13A - 90	1	13	90	46	34	36	52	—	50	40	1.3	
3970 ※ 0290100	- 120	1	13	120	66	34	36	52	—	70	40	1.6	

Medidas Métricas - Metric Sizes

Unidad : Métrico
Unit : Metric

Código Code	Modelo Model	Tipo Type	d	L	L ₁	D ₁	D ₂	D ₃	L ₀	ℓ	ℓ ₁	Kg	Llave Allen (Opcional) Hex. Wrench(Optional)
3970 ※ 0300100	NBT-AHO40 or WBT-AHO40 -PHC14A - 90	1	14	90	46	34	36	52	—	50	40	1.3	L-4T (4mm)
3970 ※ 0310100	- 120	1	14	120	66	34	36	52	—	70	40	1.6	
3970 ※ 0320100	-PHC15A - 90	1	15	90	46	36	38	52	—	50	40	1.3	
3970 ※ 0330100	- 120	1	15	120	66	36	38	52	—	70	40	1.6	
3970 ※ 0340100	-PHC16A - 90	1	16	90	46	36	38	52	—	50	40	1.3	
3970 ※ 0350100	- 120	1	16	120	66	36	38	52	—	70	40	1.6	
3970 ※ 0360100	-PHC20A - 90 *	1	20	90	49	40	42	46	—	50	40	1.3	
3970 ※ 0370100	- 120 *	1	20	120	69	40	42	46	—	70	40	1.6	
3970 ※ 0380100	-PHC25A - 105	1	25	105	59	50	52	62	—	60	50	1.9	
3970 ※ 0390100	- 135	1	25	135	79	50	52	62	—	80	50	2.4	
3970 ※ 0400100	-PHC32A - 120	3	32	120	93	60	62	62	—	75	65	2.4	L-6T (6mm)
3970 ※ 0410100	- 150	3	32	150	123	60	62	62	—	80	65	3.1	
3970 ※ 0420100	NBT-AHO50 or WBT-AHO50 -PHC06A - 90	1	6	90	30	24	26	46	—	34	29	3.1	
3970 ※ 0430100	- 120	1	6	120	41	24	26	46	—	45	29	3.4	L-4T (4mm)
3970 ※ 0440100	- 150	1	6	150	41	24	26	46	—	45	29	3.8	
3970 ※ 0450100	-PHC07A - 90	1	7	90	30	26	28	46	—	34	29	3.1	
3970 ※ 0460100	- 120	1	7	120	41	26	28	46	—	45	29	3.5	
3970 ※ 0470100	- 150	1	7	150	41	26	28	46	—	45	29	3.8	
3970 ※ 0480100	-PHC08A - 90	1	8	90	30	26	28	46	—	34	29	3.2	
3970 ※ 0490100	- 120	1	8	120	41	26	28	46	—	45	29	3.5	
3970 ※ 0500100	- 150	1	8	150	41	26	28	46	—	45	29	3.8	
3970 ※ 0510100	-PHC09A - 105	1	9	105	44	28	30	52	—	50	40	3.3	
3970 ※ 0520100	- 135	1	9	135	64	28	30	52	—	70	40	3.5	
3970 ※ 0530100	- 165	1	9	165	64	28	30	52	—	70	40	3.8	
3970 ※ 0540100	-PHC10A - 105	1	10	105	44	28	30	52	—	50	40	3.3	
3970 ※ 0550100	- 135	1	10	135	64	28	30	52	—	70	40	3.5	
3970 ※ 0560100	- 165	1	10	165	64	28	30	52	—	70	40	3.8	
3970 ※ 0570100	-PHC11A - 105	1	11	105	45	30	32	52	—	50	40	3.3	
3970 ※ 0580100	- 135	1	11	135	65	30	32	52	—	70	40	3.6	
3970 ※ 0590100	- 165	1	11	165	65	30	32	52	—	70	40	3.9	
3970 ※ 0600100	-PHC12A - 105 *	1	12	105	45	30	32	52	—	50	40	3.3	
3970 ※ 0610100	- 135 *	1	12	135	65	30	32	52	—	70	40	3.6	
3970 ※ 0620100	- 165 *	1	12	165	65	30	32	52	—	70	40	3.9	
3970 ※ 0630100	-PHC13A - 105	1	13	105	46	34	36	52	—	50	40	3.3	
3970 ※ 0640100	- 135	1	13	135	66	34	36	52	—	70	40	3.6	
3970 ※ 0650100	- 165	1	13	165	66	34	36	52	—	70	40	3.9	
3970 ※ 0660100	-PHC14A - 105	1	14	105	46	34	36	52	—	50	40	3.3	
3970 ※ 0670100	- 135	1	14	135	66	34	36	52	—	70	40	3.6	
3970 ※ 0680100	- 165	1	14	165	66	34	36	52	—	70	40	3.9	
3970 ※ 0690100	-PHC15A - 105	1	15	105	46	36	38	52	—	50	40	3.4	
3970 ※ 0700100	- 135	1	15	135	66	36	38	52	—	70	40	3.7	
3970 ※ 0710100	- 165	1	15	165	66	36	38	52	—	70	40	4.0	
3970 ※ 0720100	-PHC16A - 105	1	16	105	46	36	38	52	—	50	40	3.4	
3970 ※ 0730100	- 135	1	16	135	66	36	38	52	—	70	40	3.7	
3970 ※ 0740100	- 165	1	16	165	66	36	38	52	—	70	40	4.0	
3970 ※ 0750100	-PHC20A - 105 *	1	20	105	49	40	42	46	—	50	40	3.4	
3970 ※ 0760100	- 135 *	1	20	135	69	40	42	46	—	70	40	3.7	
3970 ※ 0770100	- 165 *	1	20	165	69	40	42	46	—	70	40	3.9	
3970 ※ 0780100	-PHC25A - 120	1	25	120	59	50	52	62	—	64	50	3.9	
3970 ※ 0790100	- 150	1	25	150	79	50	52	62	—	80	50	4.4	
3970 ※ 0800100	- 165	1	25	165	79	50	52	62	—	80	50	4.8	
3970 ※ 0810100	-PHC32A - 135	3	32	135	—	60	62	—	—	75	65	4.5	
3970 ※ 0820100	- 165	3	32	165	—	60	62	—	—	80	65	5.1	

En el código del producto reemplace ※ por Ø si desea ordenar NBT-AHO o 6 si desea ordenar WBT-AHO

- El zanco de la herramienta de corte debe estar dentro de la tolerancia especificada en la parte inferior; Diámetro del zanco menor de 6 mm : Con tolerancia de h6 o menor, Diámetro del zanco mayor de 6 mm: Dentro de la tolerancia h7 o menor, h6 o 0/-0.01mm es la tolerancia recomendada en las herramientas de corte al usar nuestros productos.
- PHC12A y PHC20A cuentan con orificios de acople para perno, para las boquillas que tienen incluido el perno de retención
- * Es posible utilizar boquillas PHS.

On the product code replace ※ for Ø if you want to order NBT-AHO or for 6 if you want to order WBT-AHO

- Cutting tool shank must be within tolerances specified below; Shank diameter less than 6mm : Within h6 tolerance, Shank diameter 6mm and over : Within h7 tolerance, h6 or 0/-0.01 tolerance is recommended when newly making a cutting tool.
- PHC12A and PHC20A have pin holes for collet with stopper pin on its body.
- * Compatible for PHS collet use.

Ejemplo para Ordenar - Ordering Example

Para/For WBT-AHO

WBT-AHO50 - PHC 12 A - 105

AHO Interfaz y diámetro de husillo
AHO Shank size

Diámetro Interior I.D.

Longitud de proyección Projection length

Ejemplo para Ordenar - Ordering Example

Para/For NBT-AHO

NBT-AHO50 - PHC 12 A - 105

AHO Interfaz y diámetro de husillo
AHO Shank size

Diámetro Interior I.D.

Longitud de proyección Projection length

Pulgada a métrico → Pulgada × 25.4

Métrico a pulgada → Métrico ÷ 25.4 ó métrico por 0.03937



Tamaños especiales / personalizados bajo pedido

AHO

BT

CAT

AHO

HSK-A/E/F/C

HSK-T

C

UTS

Máquinas Especializadas

Specialized Machine

Equipo Relacionado

Related Equipment

Taladro de Biselado & de Casquillo

Bush & Chamfering Drill

Milling Chuck

Collet Holder

"R" Zero Holder

Hydraulic Chuck

Shrink Fit

Tapping Chuck

Arbors

Function Holder

Retention Stud

PHC · SA-C

Nuevo



Portaherramienta Hidráulico Delgado "Blaster" (Para refrigeración por los costados)

Slim Hydro Chuck Blaster (For side through coolant)

- La opción perfecta para trabajos en espacios reducidos, tal como acabados en fresado, barrenado y rimado en máquinas de 5-ejes.
- Perfect choice for tight space applications, such as endmill finishing, drilling and reaming on 5-axis machines.

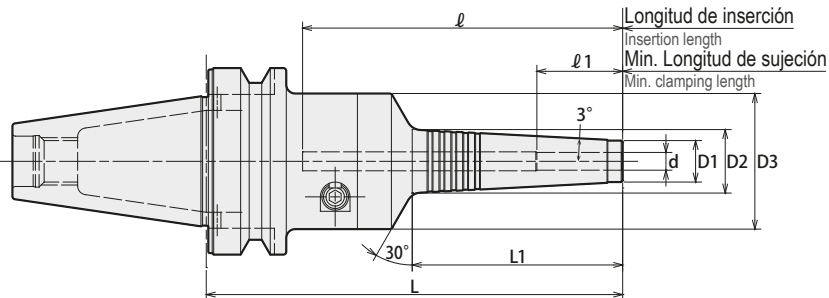

•Nuestro portaherramientas BT de doble contacto (para NBT-AHO) es incompatible con el portaherramientas BT de doble contacto (para WBT-AHO).

•Cuando el modelo "AHO" es utilizado con alimentación de refrigerante que pasa a través del centro del portaherramienta, debe de utilizarse un tornillo de retención diseñado para AHO (con pipa de refrigerante).

•Our two-face contact BT spindle (for NBT-AHO) is incompatible with BT two-face contact spindle (for WBT-AHO).

•When AHO is used with center through coolant feeding, a designated retention stud (with coolant pipe) for AHO must be used.

Código Code	Modelo Model	d	L	L1	D1	D2	D3	ℓ ₁	ℓ ₁	Llave Allen (Opcional) Wrench(Option)
3960 ※0010100	NBT-AHO30 or WBT-AHO30 -PHC03SA -85 -C	3	85	30	12	15.2	46	63	18	L-4T
3960 ※0020100	-130 -C	3	130	71	12	19.5	46	108	18	
3960 ※0030100	-PHC04SA -85 -C	4	85	30	12	15.2	46	63	24	
3960 ※0040100	-130 -C	4	130	71	12	19.5	46	108	24	
3960 ※0050100	-PHC06SA -90 -C	6	90	26	14	16.8	46	47	29	
3960 ※0060100	-135 -C	6	135	71	14	21.5	46	92	29	
3960 ※0070100	-PHC08SA -90 -C	8	90	27	16	18.9	46	47	29	
3960 ※0080100	-135 -C	8	135	72	16	23.6	46	92	29	
3960 ※0090100	-PHC10SA -105 -C	10	105	42	18	22.5	46	62	40	
3960 ※0100100	-135 -C	10	135	72	18	25.6	46	92	40	
3960 ※0110100	-PHC12SA -105 -C	12	105	43	20	24.6	46	62	40	
3960 ※0120100	-135 -C	12	135	73	20	27.7	46	92	40	
3960 ※0130100	NBT-AHO40 or WBT-AHO40 -PHC03SA -90 -C	3	90	30	12	15.2	46	63	18	L-4T
3960 ※0140100	-135 -C	3	135	71	12	19.5	46	108	18	
3960 ※0150100	-PHC04SA -90 -C	4	90	30	12	15.2	46	63	24	
3960 ※0160100	-135 -C	4	135	71	12	19.5	46	108	24	
3960 ※0170100	-PHC06SA -90 -C	6	90	26	14	16.8	46	47	29	
3960 ※0180100	-135 -C	6	135	71	14	21.5	46	92	29	
3960 ※0190100	-PHC08SA -90 -C	8	90	27	16	18.9	46	47	29	
3960 ※0200100	-135 -C	8	135	72	16	23.6	46	92	29	
3960 ※0210100	-PHC10SA -105 -C	10	105	42	18	22.5	46	62	40	
3960 ※0220100	-135 -C	10	135	72	18	25.6	46	92	40	
3960 ※0230100	-PHC12SA -105 -C	12	105	43	20	24.6	46	62	40	
3960 ※0240100	-135 -C	12	135	73	20	27.7	46	92	40	
3960 ※0250100	-PHC16SA -135 -C	16	135	72	24	31.6	52.5	90	40	
3960 ※0260100	-165 -C	16	165	103	24	34.8	52.5	120	40	
3960 ※0270100	-PHC20SA -135 -C	20	135	63	29	35.7	62	85	40	L-6T
3960 ※0280100	-180 -C	20	180	109	29	40.5	62	130	40	
3960 ※0290100	-PHC25SA -135 -C	25	135	65	38	44.9	62	85	50	
3960 ※0300100	-180 -C	25	180	112	38	49.8	62	130	50	L-4T
3960 ※0310100	NBT-AHO50 or WBT-AHO50 -PHC06SA -150 -C	6	150	71	14	21.5	46	92	29	
3960 ※0320100	-195 -C	6	195	118	14	26.4	46	137	29	
3960 ※0330100	-PHC08SA -150 -C	8	150	72	16	23.6	46	92	29	
3960 ※0340100	-195 -C	8	195	118	16	28.4	46	137	29	
3960 ※0350100	-PHC10SA -150 -C	10	150	72	18	25.6	46	92	40	
3960 ※0360100	-195 -C	10	195	119	18	30.5	46	137	40	
3960 ※0370100	-PHC12SA -150 -C	12	150	73	20	27.7	46	92	40	
3960 ※0380100	-195 -C	12	195	119	20	32.5	46	137	40	
3960 ※0390100	-PHC16SA -150 -C	16	150	72	24	31.6	52.5	90	40	
3960 ※0400100	-195 -C	16	195	119	24	36.5	52.5	135	40	
3960 ※0410100	-PHC20SA -150 -C	20	150	63	29	35.7	62	85	40	
3960 ※0420100	-195 -C	20	195	109	29	40.5	62	130	40	
3960 ※0430100	-PHC25SA -150 -C	25	150	65	38	44.9	62	85	50	
3960 ※0440100	-195 -C	25	195	112	38	49.8	62	130	50	

En el código del producto remplace ※ por Ø si desea ordenar NBT-AHO o por 6 si desea ordenar el WBT-AHO.

1. La tolerancia del diámetro del zanco de la herramienta debe estar dentro del h6.

On the product code replace ※ for Ø if you want to order NBT-AHO or for 6 if you want to order WBT-AHO

1. Tool shank diameter tolerance must be within h6.

Llave Allen Hex. Wrench

Pág. 99



Tornillo de retención Preset Screw

Pág. 266

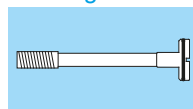

Ejemplo para Ordenar - Ordering Example

Para/For NBT-AHO

NBT-AHO50-PHC 12 SA - 150 -C

AHO Interfaz y diámetro de husillo
AHO Shank size

Diámetro Interior
I.D.

Longitud de proyección
Projection length

Ejemplo para Ordenar - Ordering Example

Para/For NBT-AHO

WBT-AHO50-PHC 12 SA - 150 -C

AHO Interfaz y diámetro de husillo
AHO Shank size

Diámetro Interior
I.D.

Longitud de proyección
Projection length

PHC · SA-NC Nuevo

Portaherramienta Hidráulico Delgado "Blaster" (Con función tipo boquilla) Slim Hydro Chuck Blaster (With cap)

- La opción perfecta para trabajos en espacios reducidos, tal como acabados en fresado, barrenado y rimado en máquinas de 5-ejes.
- Perfect choice for tight space applications, such as endmill finishing, drilling and reaming on 5-axis machines.

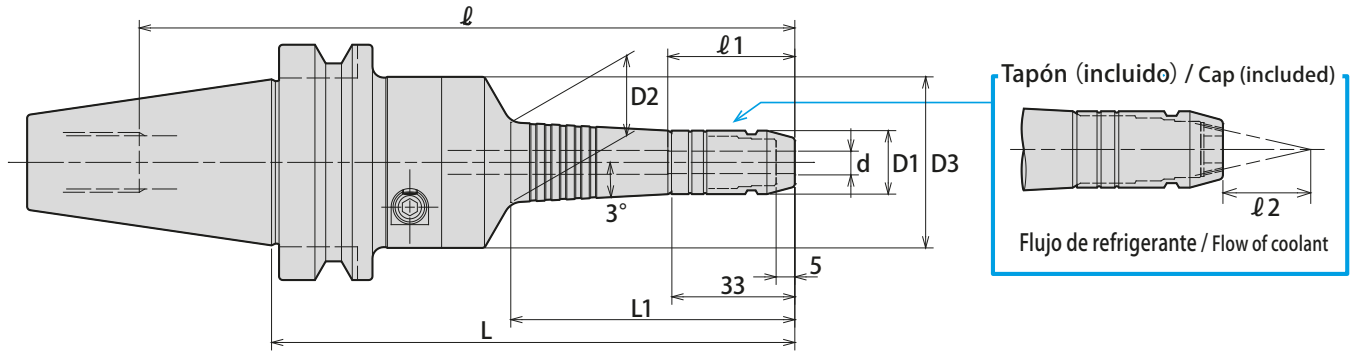

⚠ • Nuestra interfaz de doble contacto tipo "BT" (para NBT-AHO) es incompatible con el husillo BT de doble contacto (para WBT-AHO) pág. 051.
 • Cuando el modelo "AHO" es utilizado con alimentación de refrigerante que pasa a través del centro de la boquilla, debe utilizarse un perno de retención diseñado para AHO (con pipa de refrigerante).
 • Our two-face contact BT spindle (for NBT-AHO) is incompatible with BT two-face contact spindle (for WBT-AHO). Please refer to P. 051.
 • When AHO is used with center through coolant feeding, a designated retention stud (with coolant pipe) for AHO must be used.

Código Code	Modelo Model	L	L1	D1	D2	D3	l	l1	l2	Llave Allen (Opcional) Wrench(Option)
3960 60010500	WBT-AHO30 -PHC04SA -135-NC	4	135	76	15	19.5	46	113	29	L-4T
3960 60020500	-PHC06SA -140-NC	6	140	76	17	21.5	46	97	34	
3960 60030500	-PHC08SA -140-NC	8	140	77	19	23.6	46	97	34	
3960 60040500	-PHC10SA -110-NC	10	110	47	21	22.5	46	67	45	
3960 60050500	-140-NC	10	140	77	21	25.6	46	97	45	
3960 60060500	-PHC12SA -110-NC	12	110	48	23	24.6	46	67	45	
3960 60070500	-140-NC	12	140	78	23	27.7	46	97	45	60
3960 60080500	WBT-AHO40 -PHC04SA -140-NC	4	140	76	15	19.5	46	113	29	L-4T
3960 60090500	-PHC06SA -140-NC	6	140	76	17	21.5	46	97	34	
3960 60100500	-PHC08SA -140-NC	8	140	77	19	23.6	46	97	34	
3960 60110500	-PHC10SA -110-NC	10	110	47	21	22.5	46	67	45	
3960 60120500	-140-NC	10	140	77	21	25.6	46	97	45	
3960 60130500	-PHC12SA -110-NC	12	110	48	23	24.6	46	67	45	
3960 60140500	-140-NC	12	140	78	23	27.7	46	97	45	60
3960 60150500	WBT-AHO50 -PHC06SA -155-NC	6	155	76	17	21.5	46	97	34	L-4T
3960 60160500	-200-NC	6	200	123	17	26.4	46	142	34	
3960 60170500	-PHC08SA -155-NC	8	155	77	19	23.6	46	97	34	
3960 60180500	-200-NC	8	200	123	19	28.4	46	142	34	
3960 60190500	-PHC10SA -155-NC	10	155	77	21	25.6	46	97	45	
3960 60200500	-200-NC	10	200	124	21	30.5	46	142	45	
3960 60210500	-PHC12SA -155-NC	12	155	78	23	27.7	46	97	45	60
3960 60220500	-200-NC	12	200	124	23	32.5	46	142	45	60

- La tolerancia del diámetro del zanco de la herramienta debe estar dentro de h6.
 - l indica la dimensión cuando se use sin un tornillo de preajuste.
1. Tool shank diameter tolerance must be within h6.
 2. l indicates dimension when using without a preset screw.

Llave Allen Hex. Wrench	Tornillo de retención Preset Screw	Tapón Cap
Pág. 99	Pág. 266	Pág. 117
		

Ejemplo para Ordenar - Ordering Example
Para/For NBT-AHO

WBT-AHO50 - PHC 12 SA - 140-NC

AHO Interfaz y diámetro de husillo AHO Shank size	Diámetro Interior I.D.	Longitud de proyección Projection length
--	---------------------------	---

Portaherramienta Hidráulico Delgado

Slim Hydro Chuck

- La opción perfecta para trabajos en espacios reducidos, tales como acabados en fresado, barrenado y rimado en máquinas de 5-ejes.
- Perfect choice for tight space applications, such as endmill finishing, drilling and reaming on 5-axis machines.

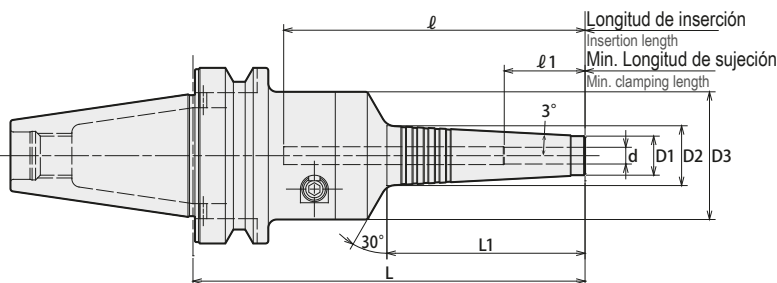

•Nuestro portaherramientas BT de doble contacto (para NBT-AHO) es incompatible con el portaherramientas BT de doble contacto (para WBT-AHO).

•Cuando el modelo "AHO" es utilizado con alimentación de refrigerante que pasa a través del centro del portaherramienta, debe de utilizarse un tornillo de retención diseñado para AHO (con pipa de refrigerante).

•Our two-face contact BT spindle (for NBT-AHO) is incompatible with BT two-face contact spindle (for WBT-AHO).

•When AHO is used with center through coolant feeding, a designated retention stud (with coolant pipe) for AHO must be used.

Código Code	Modelo Model	d	L	L1	D1	D2	D3	ℓ	ℓ1	Llave Allen (Opcional) Wrench (Option)
3720 ※0010100	NBT-AHO30 or WBT-AHO30 -PHC03SA	-70	3	70	19	11	13.0	46	48	18
3720 ※0020100		-85	3	85	30	11	14.2	46	63	18
3720 ※0030100		-130	3	130	71	11	18.5	46	108	18
3720 ※0040100	-PHC04SA	-70	4	70	19	11	13.0	46	48	24
3720 ※0050100		-85	4	85	30	11	14.2	46	63	24
3720 ※0060100		-130	4	130	71	11	18.5	46	108	24
3720 ※0070100	-PHC06SA	-90	6	90	26	13	15.8	46	47	29
3720 ※0080100		-135	6	135	71	13	20.5	46	92	29
3720 ※0090100		-150	6	150	87	13	22.2	46	107	29
3720 ※0100100		-165	6	165	102	13	23.7	46	122	29
3720 ※0110100		-180	6	180	118	13	25.4	46	137	29
3720 ※0120100	-PHC07SA	-90	7	90	26	14	16.8	46	47	29
3720 ※0130100		-135	7	135	71	14	21.5	46	92	29
3720 ※0140100		-150	7	150	87	14	23.2	46	107	29
3720 ※0150100		-165	7	165	102	14	24.7	46	122	29
3720 ※0160100		-180	7	180	118	14	26.4	46	137	29
3720 ※0170100	-PHC08SA	-90	8	90	27	15	17.9	46	47	29
3720 ※0180100		-135	8	135	72	15	22.6	46	92	29
3720 ※0190100		-150	8	150	87	15	24.2	46	107	29
3720 ※0200100		-165	8	165	103	15	25.8	46	122	29
3720 ※0210100		-180	8	180	118	15	27.4	46	137	29
3720 ※0220100	-PHC09SA	-105	9	105	42	16	20.5	46	62	40
3720 ※0230100		-135	9	135	72	16	23.6	46	92	40
3720 ※0240100		-150	9	150	87	16	25.2	46	107	40
3720 ※0250100		-165	9	165	103	16	26.8	46	122	40
3720 ※0260100		-180	9	180	118	16	28.4	46	137	40
3720 ※0270100	-PHC10SA	-105	10	105	42	17	21.5	46	62	40
3720 ※0280100		-135	10	135	72	17	24.6	46	92	40
3720 ※0290100		-150	10	150	87	17	26.3	46	107	40
3720 ※0300100		-165	10	165	103	17	27.8	46	122	40
3720 ※0310100		-180	10	180	119	17	29.5	46	137	40
3720 ※0320100	-PHC11SA	-105	11	105	43	18	22.6	46	62	40
3720 ※0330100		-135	11	135	73	18	25.7	46	92	40
3720 ※0340100		-150	11	150	88	18	27.3	46	107	40
3720 ※0350100		-165	11	165	104	18	29.0	46	122	40
3720 ※0360100		-180	11	180	119	18	30.5	46	137	40
3720 ※0370100	-PHC12SA	-105	12	105	43	19	23.6	46	62	40
3720 ※0380100		-135	12	135	73	19	26.7	46	92	40
3720 ※0390100		-150	12	150	88	19	28.3	46	107	40
3720 ※0400100		-165	12	165	104	19	30.0	46	122	40
3720 ※0410100		-180	12	180	119	19	31.5	46	137	40
3720 ※0420100	NBT-AHO40 or WBT-AHO40 -PHC03SA	-75	3	75	19	11	13.0	46	48	18
3720 ※0430100		-90	3	90	30	11	14.2	46	63	18
3720 ※0440100		-135	3	135	71	11	18.5	46	108	18
3720 ※0450100	-PHC04SA	-75	4	75	19	11	13.0	46	48	24
3720 ※0460100		-90	4	90	30	11	14.2	46	63	24
3720 ※0470100		-135	4	135	71	11	18.5	46	108	24
3720 ※0480100	-PHC06SA	-90	6	90	26	13	15.8	46	47	29
3720 ※0490100		-135	6	135	71	13	20.5	46	92	29
3720 ※0500100		-150	6	150	87	13	22.2	46	107	29
3720 ※0510100		-165	6	165	102	13	23.7	46	122	29
3720 ※0520100		-180	6	180	118	13	25.4	46	137	29
3720 ※0530100	-PHC07SA	-90	7	90	26	14	16.8	46	47	29
3720 ※0540100		-135	7	135	71	14	21.5	46	92	29
3720 ※0550100		-150	7	150	87	14	23.2	46	107	29
3720 ※0560100		-165	7	165	102	14	24.7	46	122	29
3720 ※0570100		-180	7	180	118	14	26.4	46	137	29
3720 ※0580100	-PHC08SA	-90	8	90	27	15	17.9	46	47	29
3720 ※0590100		-135	8	135	72	15	22.6	46	92	29
3720 ※0600100		-150	8	150	87	15	24.2	46	107	29
3720 ※0610100		-165	8	165	103	15	25.8	46	122	29
3720 ※0620100		-180	8	180	118	15	27.4	46	137	29

L-4T

L-4T

Código Code	Modelo Model		d	L	L1	D1	D2	D3	ℓ	ℓ1	Llave Allen (Opcional) Wrench(Option)	
3720 *0630100	NBT-AHO40 or WBT-AHO40	-PHC09SA	-105	9	105	42	16	20.5	46	62	40	L-4T
3720 *0640100			-135	9	135	72	16	23.6	46	92	40	
3720 *0650100			-150	9	150	87	16	25.2	46	107	40	
3720 *0660100			-165	9	165	103	16	26.8	46	122	40	
3720 *0670100			-180	9	180	118	16	28.4	46	137	40	
3720 *0680100		-PHC10SA	-105	10	105	42	17	21.5	46	62	40	
3720 *0690100			-135	10	135	72	17	24.6	46	92	40	
3720 *0700100			-150	10	150	87	17	26.3	46	107	40	
3720 *0710100			-165	10	165	103	17	27.8	46	122	40	
3720 *0720100			-180	10	180	119	17	29.5	46	137	40	
3720 *0730100		-PHC11SA	-105	11	105	43	18	22.6	46	62	40	
3720 *0740100			-135	11	135	73	18	25.7	46	92	40	
3720 *0750100			-150	11	150	88	18	27.3	46	107	40	
3720 *0760100			-165	11	165	104	18	29.0	46	122	40	
3720 *0770100			-180	11	180	119	18	30.5	46	137	40	
3720 *0780100		-PHC12SA	-105	12	105	43	19	23.6	46	62	40	
3720 *0790100			-135	12	135	73	19	26.7	46	92	40	
3720 *0800100			-150	12	150	88	19	28.3	46	107	40	
3720 *0810100			-165	12	165	104	19	30.0	46	122	40	
3720 *0820100			-180	12	180	119	19	31.5	46	137	40	
3720 *0830100		-PHC16SA	-135	16	135	72	23	30.6	52.5	90	40	
3720 *0840100			-165	16	165	103	23	33.8	52.5	120	40	
3720 *0850100			-180	16	180	119	23	35.5	52.5	135	40	
3720 *0860100		-PHC20SA	-135	20	135	63	28	34.7	62	85	40	
3720 *0870100			-165	20	165	93	28	37.8	62	115	40	
3720 *0880100			-180	20	180	109	28	39.5	62	130	40	
3720 *0890100		-PHC25SA	-135	25	135	65	37	43.9	62	85	50	
3720 *0900100			-165	25	165	96	37	47.1	62	115	50	
3720 *0910100			-180	25	180	112	37	48.8	62	130	50	
3720 *0920100	NBT-AHO50 or WBT-AHO50	-PHC06SA	-105	6	105	26	13	15.8	46	47	29	L-4T
3720 *0930100			-150	6	150	71	13	20.5	46	92	29	
3720 *0940100			-165	6	165	87	13	22.2	46	107	29	
3720 *0950100			-180	6	180	102	13	23.7	46	122	29	
3720 *0960100			-195	6	195	118	13	25.4	46	137	29	
3720 *0970100		-PHC07SA	-105	7	105	26	14	16.8	46	47	29	
3720 *0980100			-150	7	150	71	14	21.5	46	92	29	
3720 *0990100			-165	7	165	87	14	23.2	46	107	29	
3720 *1000100			-180	7	180	102	14	24.7	46	122	29	
3720 *1010100			-195	7	195	118	14	26.4	46	137	29	
3720 *1020100		-PHC08SA	-105	8	105	27	15	17.9	46	47	29	
3720 *1030100			-150	8	150	72	15	22.6	46	92	29	
3720 *1040100			-165	8	165	87	15	24.2	46	107	29	
3720 *1050100			-180	8	180	103	15	25.8	46	122	29	
3720 *1060100			-195	8	195	118	15	27.4	46	137	29	
3720 *1070100		-PHC09SA	-150	9	150	72	16	23.6	46	92	40	
3720 *1080100			-165	9	165	87	16	25.2	46	107	40	
3720 *1090100			-180	9	180	103	16	26.8	46	122	40	
3720 *1100100			-195	9	195	118	16	28.4	46	137	40	
3720 *1110100		-PHC10SA	-150	10	150	72	17	24.6	46	92	40	
3720 *1120100			-165	10	165	87	17	26.3	46	107	40	
3720 *1130100			-180	10	180	103	17	27.8	46	122	40	
3720 *1140100			-195	10	195	119	17	29.5	46	137	40	
3720 *1150100		-PHC11SA	-150	11	150	73	18	25.7	46	92	40	
3720 *1160100			-165	11	165	88	18	27.3	46	107	40	
3720 *1170100			-180	11	180	104	18	29.0	46	122	40	
3720 *1180100			-195	11	195	119	18	30.5	46	137	40	
3720 *1190100		-PHC12SA	-150	12	150	73	19	26.7	46	92	40	
3720 *1200100			-165	12	165	88	19	28.3	46	107	40	
3720 *1210100			-180	12	180	104	19	30.0	46	122	40	
3720 *1220100			-195	12	195	119	19	31.5	46	137	40	
3720 *1230100		-PHC16SA	-150	16	150	72	23	30.6	52.5	90	40	
3720 *1240100			-180	16	180	103	23	33.8	52.5	120	40	
3720 *1250100			-195	16	195	119	23	35.5	52.5	135	40	
3720 *1260100		-PHC20SA	-150	20	150	63	28	34.7	62	85	40	
3720 *1270100			-180	20	180	93	28	37.8	62	115	40	
3720 *1280100			-195	20	195	109	28	39.5	62	130	40	
3720 *1290100		-PHC25SA	-150	25	150	65	37	43.9	62	85	50	
3720 *1300100			-180	25	180	96	37	47.1	62	115	50	
3720 *1310100			-195	25	195	112	37	48.8	62	130	50	

En el código del producto remplace * por Ø si desea ordenar NBT-AHO o por 6 si desea ordenar el WBT-AHO.

1. La tolerancia del diámetro del zanco de la herramienta debe estar dentro del h6. 1. La tolerancia del diámetro del zanco de la herramienta debe estar dentro del h6.

On the product code replace * for Ø if you want to order NBT-AHO or for 6 if you want to order WBT-AHO

1. Tool shank diameter tolerance must be within h6.

Ejemplo para Ordenar - Ordering Example

Para / For NBT-AHO

NBT-AHO50-PHC 12 SA- 150

AHO Interfaz
y diámetro del husillo
AHO Shank size

Diámetro
Interior
I.D.

Longitud de
proyección
Projection length

Ejemplo para Ordenar - Ordering Example

Para / For WBT-AHO

WBT-AHO50-PHC 12 SA- 150

AHO Interfaz y
diámetro del husillo
AHO Shank size

Diámetro
Interior
I.D.

Longitud de
proyección
Projection length

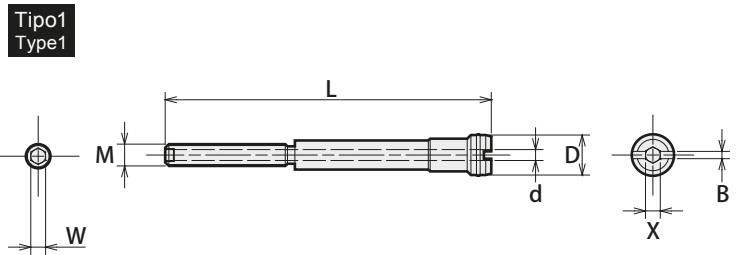
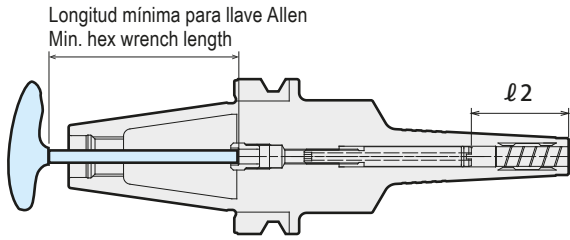

Tipo1
Type1

Interfaz y diámetro de husillo Shank size	Longitud mínima para llave Allen Min. hex wrench length
AHO30	-
AHO40	107mm
AHO50	165mm

La llave Allen no puede ser utilizada con el modelo AHO30. Para realizar ajustes utilice un desatornillador plano.
A hex wrench cannot be used with AHO30. Please use a flathead screwdriver for adjustments.

Tornillo de preajuste presert screw		Portaherramienta correspondiente Matched chuck		Rango de ajuste Adjustment range l2	Cantidad de ajuste Adjustment amount	Tipo Type	W	X	B	D	d	L	M
Código Code	Modelo Model												
3704 00060810	PHCSA -P06 -081	NBT-AHO30 or WBT-AHO30		-90	29~44	15	1	*	-	2	6	3	22
3704 00060820	PHCSA -P06 -082			-135	29~49	20	1	*	-	2	6	3	67
3704 00060830	PHCSA -P06 -083			-150	29~49	20	1	*	-	2	6	3	82
3704 00060840	PHCSA -P06 -084			-165	29~49	20	1	*	-	2	6	3	97
3704 00060850	PHCSA -P06 -085			-180	29~49	20	1	*	-	2	6	3	112
3704 00060810	PHCSA -P06 -081			-90	29~44	15	1	*	-	2	6	3	22
3704 00070820	PHCSA -P07 -082			-135	29~49	20	1	*	-	2	7	2	67
3704 00070830	PHCSA -P07 -083			-150	29~49	20	1	*	-	2	7	2	82
3704 00070840	PHCSA -P07 -084			-165	29~49	20	1	*	-	2	7	2	97
3704 00070850	PHCSA -P07 -085			-180	29~49	20	1	*	-	2	7	2	112
3704 00060810	PHCSA -P06 -081			-90	29~44	15	1	*	-	2	6	3	22
3704 00080820	PHCSA -P08 -082			-135	29~49	20	1	*	-	2	8	3	67
3704 00080830	PHCSA -P08 -083			-150	29~49	20	1	*	-	2	8	3	82
3704 00080840	PHCSA -P08 -084			-165	29~49	20	1	*	-	2	8	3	97
3704 00080850	PHCSA -P08 -085			-180	29~49	20	1	*	-	2	8	3	112
3704 00090810	PHCSA -P09 -081			-105	40~59	19	1	*	-	2	9	3	26
3704 00090820	PHCSA -P09 -082			-135	40~60	20	1	*	-	2	9	3	56
3704 00090830	PHCSA -P09 -083			-150	40~60	20	1	*	-	2	9	3	71
3704 00090840	PHCSA -P09 -084			-165	40~60	20	1	*	-	2	9	3	86
3704 00090850	PHCSA -P09 -085			-180	40~60	20	1	*	-	2	9	3	101
3704 00090810	PHCSA -P09 -081			-105	40~59	19	1	*	-	2	9	3	26
3704 00100820	PHCSA -P10 -082			-135	40~60	20	1	*	-	2	10	3	56
3704 00100830	PHCSA -P10 -083			-150	40~60	20	1	*	-	2	10	3	71
3704 00100840	PHCSA -P10 -084			-165	40~60	20	1	*	-	2	10	3	86
3704 00100850	PHCSA -P10 -085			-180	40~60	20	1	*	-	2	10	3	101
3704 00090810	PHCSA -P09 -081			-105	40~59	19	1	*	-	2	9	3	26
3704 00110820	PHCSA -P11 -082			-135	40~60	20	1	*	-	2	11	3	56
3704 00110830	PHCSA -P11 -083			-150	40~60	20	1	*	-	2	11	3	71
3704 00110840	PHCSA -P11 -084			-165	40~60	20	1	*	-	2	11	3	86
3704 00110850	PHCSA -P11 -085			-180	40~60	20	1	*	-	2	11	3	101
3704 00090810	PHCSA -P09 -081			-105	40~59	19	1	*	-	2	9	3	26
3704 00120820	PHCSA -P12 -082			-135	40~60	20	1	*	-	2	12	3	56
3704 00120830	PHCSA -P12 -083			-150	40~60	20	1	*	-	2	12	3	71
3704 00120840	PHCSA -P12 -084			-165	40~60	20	1	*	-	2	12	3	86
3704 00120850	PHCSA -P12 -085			-180	40~60	20	1	*	-	2	12	3	101
3704 00060810	PHCSA -P06 -081	NBT-AHO40 or WBT-AHO40		-90	29~44	15	1	3	-	2	6	3	22
3704 00060820	PHCSA -P06 -082			-135	29~49	20	1	3	-	2	6	3	67
3704 00060830	PHCSA -P06 -083			-150	29~49	20	1	3	-	2	6	3	82
3704 00060840	PHCSA -P06 -084			-165	29~49	20	1	3	-	2	6	3	97
3704 00060850	PHCSA -P06 -085			-180	29~49	20	1	3	-	2	6	3	112
3704 00060810	PHCSA -P06 -081			-90	29~44	15	1	3	-	2	6	3	22
3704 00070820	PHCSA -P07 -082			-135	29~49	20	1	3	-	2	7	2	67
3704 00070830	PHCSA -P07 -083			-150	29~49	20	1	3	-	2	7	2	82
3704 00070840	PHCSA -P07 -084			-165	29~49	20	1	3	-	2	7	2	97
3704 00070850	PHCSA -P07 -085			-180	29~49	20	1	3	-	2	7	2	112
3704 00060810	PHCSA -P06 -081			-90	29~44	15	1	3	-	2	6	3	22
3704 00080820	PHCSA -P08 -082			-135	29~49	20	1	3	-	2	8	3	67
3704 00080830	PHCSA -P08 -083			-150	29~49	20	1	3	-	2	8	3	82
3704 00080840	PHCSA -P08 -084			-165	29~49	20	1	3	-	2	8	3	97
3704 00080850	PHCSA -P08 -085			-180	29~49	20	1	3	-	2	8	3	112
3704 00090810	PHCSA -P09 -081			-105	40~59	19	1	3	3	2	9	3	26
3704 00090820	PHCSA -P09 -082			-135	40~60	20	1	3	3	2	9	3	56
3704 00090830	PHCSA -P09 -083			-150	40~60	20	1	3	3	2	9	3	71
3704 00090840	PHCSA -P09 -084			-165	40~60	20	1	3	3	2	9	3	86
3704 00090850	PHCSA -P09 -085			-180	40~60	20	1	3	3	2	9	3	101

M6
P=1

M6
P=1

Tornillo de preajuste preset screw		Portaherramienta correspondiente Matched chuck	Rango de ajuste Adjustment range ℓ 2	Cantidad de ajuste Adjustment amount	Tipo Type	W	X	B	D	d	L	M	
Código Code	Modelo Model												
3704 00090810	PHCSA -P09 -081	NBT-AHO40 or WBT-AHO40	-105	40~59	19	1	3	3	2	9	3	26	M6 P=1
3704 00100820	PHCSA -P10 -082		-135	40~60	20	1	3	3	2	10	3	56	
3704 00100830	PHCSA -P10 -083		-150	40~60	20	1	3	3	2	10	3	71	
3704 00100840	PHCSA -P10 -084		-165	40~60	20	1	3	3	2	10	3	86	
3704 00100850	PHCSA -P10 -085		-180	40~60	20	1	3	3	2	10	3	101	
3704 00090810	PHCSA -P09 -081		-105	40~59	19	1	3	3	2	9	3	26	
3704 00110820	PHCSA -P11 -082		-135	40~60	20	1	3	3	2	11	3	56	
3704 00110830	PHCSA -P11 -083		-150	40~60	20	1	3	3	2	11	3	71	
3704 00110840	PHCSA -P11 -084		-165	40~60	20	1	3	3	2	11	3	86	
3704 00110850	PHCSA -P11 -085		-180	40~60	20	1	3	3	2	11	3	101	
3704 00090810	PHCSA -P09 -081		-105	40~59	19	1	3	3	2	9	3	26	
3704 00120820	PHCSA -P12 -082		-135	40~60	20	1	3	3	2	12	3	56	
3704 00120830	PHCSA -P12 -083		-150	40~60	20	1	3	3	2	12	3	71	
3704 00120840	PHCSA -P12 -084		-165	40~60	20	1	3	3	2	12	3	86	
3704 00120850	PHCSA -P12 -085		-180	40~60	20	1	3	3	2	12	3	101	
3704 00160810	PHCSA -P16 -081		-135	40~63	23	1	3	3	2	16	3	55	
3704 00160820	PHCSA -P16 -082		-165	40~63	23	1	3	3	2	16	3	85	
3704 00160830	PHCSA -P16 -083		-180	40~63	23	1	3	3	2	16	3	100	
3704 00200810	PHCSA -P20 -081		-135	40~68	28	1	3	3	2	20	3	50	
3704 00200820	PHCSA -P20 -082		-165	40~68	28	1	3	3	2	20	3	80	
3704 00200830	PHCSA -P20 -083		-180	40~68	28	1	3	3	2	20	3	95	
3704 00250810	PHCSA -P25 -081		-135	50~77	27	1	3	3	2	25	3	41	
3704 00250820	PHCSA -P25 -082		-165	50~77	27	1	3	3	2	25	3	71	
3704 00250830	PHCSA -P25 -083		-180	50~77	27	1	3	3	2	25	3	86	
3704 00060810	PHCSA -P06 -081	NBT-AHO50 or WBT-AHO50	-105	29~44	15	1	3	-	2	6	3	22	M6 P=1
3704 00060820	PHCSA -P06 -082		-150	29~49	20	1	3	-	2	6	3	67	
3704 00060830	PHCSA -P06 -083		-165	29~49	20	1	3	-	2	6	3	82	
3704 00060840	PHCSA -P06 -084		-180	29~49	20	1	3	-	2	6	3	97	
3704 00060850	PHCSA -P06 -085		-195	29~49	20	1	3	-	2	6	3	112	
3704 00060810	PHCSA -P06 -081		-105	29~44	15	1	3	-	2	6	3	22	
3704 00070820	PHCSA -P07 -082		-150	29~49	20	1	3	-	2	7	2	67	
3704 00070830	PHCSA -P07 -083		-165	29~49	20	1	3	-	2	7	2	82	
3704 00070840	PHCSA -P07 -084		-180	29~49	20	1	3	-	2	7	2	97	
3704 00070850	PHCSA -P07 -085		-195	29~49	20	1	3	-	2	7	2	112	
3704 00060810	PHCSA -P06 -081		-105	29~44	15	1	3	-	2	6	3	22	
3704 00080820	PHCSA -P08 -082		-150	29~49	20	1	3	-	2	8	3	67	
3704 00080830	PHCSA -P08 -083		-165	29~49	20	1	3	-	2	8	3	82	
3704 00080840	PHCSA -P08 -084		-180	29~49	20	1	3	-	2	8	3	97	
3704 00080850	PHCSA -P08 -085		-195	29~49	20	1	3	-	2	8	3	112	
3704 00090820	PHCSA -P09 -082		-150	40~60	20	1	3	3	2	9	3	56	
3704 00090830	PHCSA -P09 -083		-165	40~60	20	1	3	3	2	9	3	71	
3704 00090840	PHCSA -P09 -084		-180	40~60	20	1	3	3	2	9	3	86	
3704 00090850	PHCSA -P09 -085		-195	40~60	20	1	3	3	2	9	3	101	
3704 00100820	PHCSA -P10 -082		-150	40~60	20	1	3	3	2	10	3	56	
3704 00100830	PHCSA -P10 -083		-165	40~60	20	1	3	3	2	10	3	71	
3704 00100840	PHCSA -P10 -084		-180	40~60	20	1	3	3	2	10	3	86	
3704 00100850	PHCSA -P10 -085		-195	40~60	20	1	3	3	2	10	3	101	
3704 00110820	PHCSA -P11 -082		-150	40~60	20	1	3	3	2	11	3	56	
3704 00110830	PHCSA -P11 -083		-165	40~60	20	1	3	3	2	11	3	71	
3704 00110840	PHCSA -P11 -084		-180	40~60	20	1	3	3	2	11	3	86	
3704 00110850	PHCSA -P11 -085		-195	40~60	20	1	3	3	2	11	3	101	
3704 00120820	PHCSA -P12 -082		-150	40~60	20	1	3	3	2	12	3	56	
3704 00120830	PHCSA -P12 -083		-165	40~60	20	1	3	3	2	12	3	71	
3704 00120840	PHCSA -P12 -084		-180	40~60	20	1	3	3	2	12	3	86	
3704 00120850	PHCSA -P12 -085		-195	40~60	20	1	3	3	2	12	3	101	
3704 00160710	PHCSA -P16 -071		-150	40~85	45	1	3	3	2	16	3	55	
3704 00160720	PHCSA -P16 -072		-180	40~80	40	1	3	3	2	16	3	85	
3704 00160730	PHCSA -P16 -073		-195	40~80	40	1	3	3	2	16	3	100	
3704 00200710	PHCSA -P20 -071		-150	40~80	40	1	3	3	2	20	3	50	
3704 00200720	PHCSA -P20 -072		-180	40~80	40	1	3	3	2	20	3	80	
3704 00200730	PHCSA -P20 -073		-195	40~80	40	1	3	3	2	20	3	95	
3704 00250710	PHCSA -P25 -071		-150	50~80	30	1	3	3	2	25	3	41	
3704 00250720	PHCSA -P25 -072		-180	50~90	40	1	3	3	2	25	3	71	
3704 00250730	PHCSA -P25 -073		-195	50~90	40	1	3	3	2	25	3	86	

※ AHO30 los tornillos de preajuste no pueden ser ajustados desde el lateral de la perilla de retención
Los tornillos de preajuste no pueden ser utilizados con los modelos PHC03SA y PHC04SA.

※ AHO30 preset screws cannot be adjusted from the retention knob side.
Preset screws cannot be used with PHC03SA and PHC04SA models.

PHC-H

Hydro Chuck Ω

- El Hydro Chuck de alta rigidez es la mejor opción para maquinados pesados (de alto impacto).
- High Rigidity Hydro Chuck is the best holder for high efficiency rough machining.

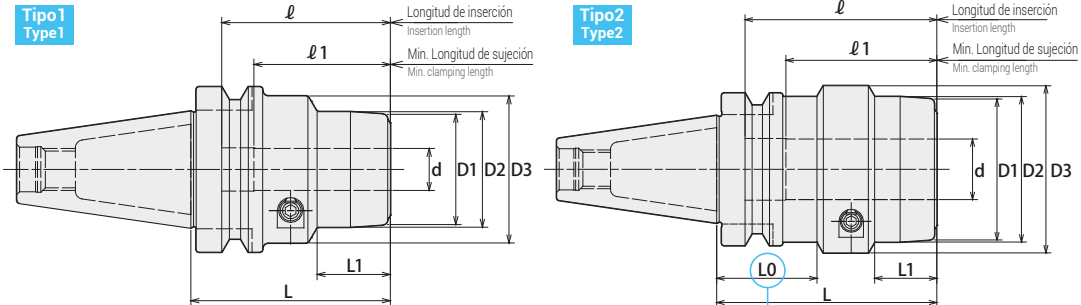

• Nuestra interfaz de doble contacto tipo "BT" (para NBT-AHO) es incompatible con el husillo BT de doble contacto (para WBT-AHO).
 • Cuando el modelo "AHO" es utilizado con alimentación de refrigerante que pasa a través del centro de la boquilla, debe utilizarse un perno de retención diseñado para AHO (con pipa de refrigerante).
 • Our two-face contact BT spindle (for NBT-AHO) is incompatible with BT two-face contact spindle (for WBT-AHO).
 • When AHO is used with center through coolant feeding, a designated retention stud (with coolant pipe) for AHO must be used.



Precaución/Caution

Tenga precaución, revise que no tenga interferencia el brazo A.T.C. (automatic tool changer) y el cartucho de herramientas.
 Take caution against A.T.C. arm and tool magazine interference.

Código Code	Modelo Model	Tipo Type	d	L	L1	D1	D2	D3	L0	ℓ	ℓ1	kg	Llave Allen (Opcional) Hex. Wrench (Optional)
3710 ※ 0010000	NBT-AHO40 or WBT-AHO40 -PHC16H - 75	1	16	75	27	42	44	56	—	60	45		L-4T
3710 ※ 0020000	-PHC20H - 75	1	20	75	32	48	50	60	—	60	50		
3710 ※ 0030000	- 105	1	20	105	32	48	50	60	—	90	50		
3710 ※ 0040000	-PHC25H - 80	2	25	80	25	58	60	69	36	65	55		L-5T
3710 ※ 0050000	- 105	2	25	105	35	58	60	69	41	90	55		
3710 ※ 0060000	-PHC32H - 105	2	32	105	40	63	65	75	41	90	65		
3710 ※ 0070000	- 135	2	32	135	47	63	65	75	41	120	65		
3710 ※ 0080000	NBT-AHO50 or WBT-AHO50 -PHC16H - 75	1	16	75	17	—	44	56	—	51	45		L-4T
3710 ※ 0090000	- 105	1	16	105	27	—	44	56	—	80	45		
3710 ※ 0100000	-PHC20H - 75	1	20	75	17	—	50	60	—	56	50		
3710 ※ 0110000	- 105	1	20	105	32	48	50	60	—	80	50		L-5T
3710 ※ 0120000	-PHC25H - 85	1	25	85	27	—	60	69	—	62	55		
3710 ※ 0130000	- 105	1	25	105	35	58	60	69	—	80	55		
3710 ※ 0140000	- 135	1	25	135	35	58	60	69	—	110	55		L-6T
3710 ※ 0150000	-PHC32H - 105	1	32	105	47	63	65	75	—	78	65		
3710 ※ 0160000	- 135	1	32	135	47	63	65	75	—	110	65		
3710 ※ 0170000	-PHC42H - 105	1	42	105	46	78	80	90	—	84	73		L-6T
3710 ※ 0180000	- 135	1	42	135	52	78	80	90	—	110	73		

En el código del producto reemplace ※ por Ø si desea ordenar NBT-AHO, o por 6 si desea WBT-AHO.

1. La tolerancia del diámetro del zanco de la herramienta debe estar dentro de h7. Es recomendada una tolerancia h6 o 0/-0.01 para nuevas herramientas de corte.
2. PHC20H Y PHC32H cuentan con orificios de acople para perno, para las boquillas que tienen incluida la clavija de torque opresor.
3. Los tornillos de retención no pueden ser utilizados.

On the product code replace ※ for Ø if you want to order NBT-AHO, or for 6 if you want to order WBT-AHO.

1. Tool shank diameter tolerance must be within h7. h6 or 0/-0.01 tolerance is recommended when newly making a cutting tool.
2. PHC20H and PHC32H have pin holes for collet with stopper pin on its body.
3. Stopper bolts cannot be used.

Ejemplo para Ordenar - Ordering Example

Para/For NBT-AHO

NBT-AHO50 - PHC 16 H - 75

AHO Interfaz y
diámetro de husillo
AHO Shank size

Diámetro
Interno
I.D.

Longitud de
proyección
Projection length

Ejemplo para Ordenar - Ordering Example

Para/For WBT-AHO

WBT-AHO50 - PHC 16 H - 75

AHO Interfaz y
diámetro de husillo
AHO Shank size

Diámetro
Interno
I.D.

Longitud de
proyección
Projection length

Boquilla PHS+H
PHS+H Collet

Pág. 123

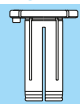

NOTAS

Shrink Fit (DIN Standard)

- El método de contracción sujeta firmemente a una herramienta de corte al calentar y enfriar el portaherramienta. Alta precisión y mucha fuerza de fresado. (Para DIN)
- Shrinkage method clamps a cutting tool firmly by heating and cooling the chuck. High precision, rigidity and strong Clamping force. (DIN Type)

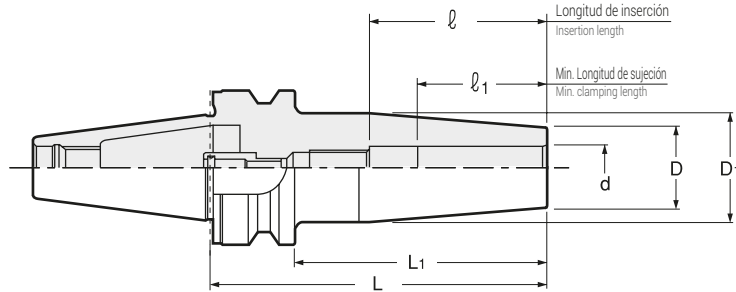

- Nuestro portaherramientas NBT de doble contacto es incompatible con el portaherramientas BT de doble contacto (para WBT-AHO). Por favor consultar pág. 50
- Cuando el modelo "AHO" es utilizado con alimentación de refrigerante que pasa a través del centro del portaherramienta, debe utilizarse un tornillo de retención diseñado para AHO (con pipa de refrigerante).
- Our two-face contact NBT spindle is incompatible with BT two-face contact spindle (for WBT-AHO). Please refer to p.50
- When AHO is used with center through coolant feeding, a designated retention stud (with coolant pipe) for AHO must be used.



Medidas Métricas - Metric Sizes

Unidad : Métrico
Unit : Metric

Código Code	Modelo Model		d	L	L1	D	D1	ℓ1	ℓ
3820 ※ 2010000	NBT-AHO30 or WBT-AHO30	-SRD6A -80	6	80	58	21	27	26	26 ~ 36
3820 ※ 2020000		-105	6	105	83	21	27	26	26 ~ 36
3820 ※ 2030000		-120	6	120	98	21	27	26	26 ~ 36
3820 ※ 2040000	NBT-AHO30 or WBT-AHO30	-SRD8A -80	8	80	58	21	27	26	26 ~ 36
3820 ※ 2050000		-105	8	105	83	21	27	26	26 ~ 50
3820 ※ 2060000		-120	8	120	98	21	27	26	26 ~ 50
3820 ※ 2070000	NBT-AHO30 or WBT-AHO30	-SRD10A -80	10	80	58	24	32	32	32 ~ 42
3820 ※ 2080000		-105	10	105	83	24	32	32	32 ~ 50
3820 ※ 2090000		-120	10	120	98	24	32	32	32 ~ 50
3820 ※ 2100000	NBT-AHO30 or WBT-AHO30	-SRD12A -90	12	90	68	24	32	37	37 ~ 47
3820 ※ 2110000		-105	12	105	83	24	32	37	37 ~ 60
3820 ※ 2120000		-120	12	120	98	24	32	37	37 ~ 70
3820 ※ 2130000	NBT-AHO30 or WBT-AHO30	-SRD14A -90	14	90	68	27	34	37	37 ~ 47
3820 ※ 2140000		-105	14	105	83	27	34	37	37 ~ 60
3820 ※ 2150000		-120	14	120	98	27	34	37	37 ~ 70
3820 ※ 2160000	NBT-AHO30 or WBT-AHO30	-SRD16A -90	16	90	68	27	34	40	40 ~ 50
3820 ※ 2170000		-105	16	105	83	27	34	40	40 ~ 60
3820 ※ 2180000		-120	16	120	98	27	34	40	40 ~ 70
3820 ※ 2190000	NBT-AHO40 or WBT-AHO40	-SRD6A -90	6	90	63	21	27	26	26 ~ 36
3820 ※ 2200000		-120	6	120	93	21	27	26	26 ~ 36
3820 ※ 2210000		-160	6	160	133	21	27	26	26 ~ 36
3820 ※ 2220000	NBT-AHO40 or WBT-AHO40	-SRD8A -90	8	90	63	21	27	26	26 ~ 50
3820 ※ 2230000		-120	8	120	93	21	27	26	26 ~ 50
3820 ※ 2240000		-160	8	160	133	21	27	26	26 ~ 50
3820 ※ 2250000	NBT-AHO40 or WBT-AHO40	-SRD10A -90	10	90	63	24	32	32	32 ~ 50
3820 ※ 2260000		-120	10	120	93	24	32	32	32 ~ 50
3820 ※ 2270000		-160	10	160	133	24	32	32	32 ~ 50
3820 ※ 2280000	NBT-AHO40 or WBT-AHO40	-SRD12A -90	12	90	63	24	32	37	37 ~ 55
3820 ※ 2290000		-120	12	120	93	24	32	37	37 ~ 70
3820 ※ 2300000		-160	12	160	133	24	32	37	37 ~ 70
3820 ※ 2310000	NBT-AHO40 or WBT-AHO40	-SRD14A -90	14	90	63	27	34	37	37 ~ 60
3820 ※ 2320000		-120	14	120	93	27	34	37	37 ~ 70
3820 ※ 2330000		-160	14	160	133	27	34	37	37 ~ 70
3820 ※ 2340000	NBT-AHO40 or WBT-AHO40	-SRD16A -90	16	90	63	27	34	40	40 ~ 60
3820 ※ 2350000		-120	16	120	93	27	34	40	40 ~ 70
3820 ※ 2360000		-160	16	160	133	27	34	40	40 ~ 80

Medidas Métricas - Metric Sizes

Unidad : Métrico
Unit : Metric

Código Code	Modelo Model	d	L	L1	D	D1	ℓ1	ℓ
3820 ※ 2370000	NBT-AHO40 or WBT-AHO40 -SRD18A -105	18	105	78	33	42	40	40 ~ 60
3820 ※ 2380000	-120	18	120	93	33	42	40	40 ~ 70
3820 ※ 2390000	-160	18	160	133	33	42	40	40 ~ 80
3820 ※ 2400000	NBT-AHO40 or WBT-AHO40 -SRD20A -105	20	105	78	33	42	42	42 ~ 60
3820 ※ 2410000	-120	20	120	93	33	42	42	42 ~ 70
3820 ※ 2420000	-160	20	160	133	33	42	42	42 ~ 100
3820 ※ 2430000	NBT-AHO40 or WBT-AHO40 -SRD25A -105	25	105	78	44	53	48	48 ~ 60
3820 ※ 2440000	-120	25	120	93	44	53	48	48 ~ 70
3820 ※ 2450000	-160	25	160	133	44	53	48	48 ~ 105
3820 ※ 2460000	NBT-AHO40 or WBT-AHO40 -SRD32A -105	32	105	78	44	53	52	52 ~ 60
3820 ※ 2470000	-120	32	120	93	44	53	52	52 ~ 70
3820 ※ 2480000	-160	32	160	133	44	53	52	52 ~ 105
3820 ※ 2490000	NBT-AHO50 or WBT-AHO50 -SRD6A -100	6	100	62	21	27	26	26 ~ 36
3820 ※ 2500000	-120	6	120	82	21	27	26	26 ~ 50
3820 ※ 2510000	-160	6	160	122	21	27	26	37 ~ 55
3820 ※ 2520000	NBT-AHO50 or WBT-AHO50 -SRD8A -100	8	100	62	21	27	26	37 ~ 70
3820 ※ 2530000	-120	8	120	82	21	27	26	37 ~ 60
3820 ※ 2540000	-160	8	160	122	21	27	26	37 ~ 70
3820 ※ 2550000	NBT-AHO50 or WBT-AHO50 -SRD10A -100	10	100	62	24	32	32	37 ~ 70
3820 ※ 2560000	-120	10	120	82	24	32	32	32 ~ 50
3820 ※ 2570000	-160	10	160	122	24	32	32	32 ~ 50
3820 ※ 2580000	NBT-AHO50 or WBT-AHO50 -SRD12A -100	12	100	62	24	32	37	32 ~ 50
3820 ※ 2590000	-120	12	120	82	24	32	37	32 ~ 50
3820 ※ 2600000	-160	12	160	122	24	32	37	32 ~ 50
3820 ※ 2610000	NBT-AHO50 or WBT-AHO50 -SRD14A -100	14	100	62	27	34	37	32 ~ 50
3820 ※ 2620000	-120	14	120	82	27	34	37	32 ~ 50
3820 ※ 2630000	-160	14	160	122	27	34	37	32 ~ 50
3820 ※ 2640000	NBT-AHO50 or WBT-AHO50 -SRD16A -105	16	105	67	27	34	40	40 ~ 60
3820 ※ 2650000	-120	16	120	82	27	34	40	40 ~ 70
3820 ※ 2660000	-160	16	160	122	27	34	40	40 ~ 80
3820 ※ 2670000	NBT-AHO50 or WBT-AHO50 -SRD18A -105	18	105	67	33	42	40	40 ~ 60
3820 ※ 2680000	-120	18	120	82	33	42	40	40 ~ 70
3820 ※ 2690000	-160	18	160	122	33	42	40	40 ~ 80
3820 ※ 2700000	NBT-AHO50 or WBT-AHO50 -SRD20A -105	20	105	67	33	42	42	42 ~ 60
3820 ※ 2710000	-120	20	120	82	33	42	42	42 ~ 70
3820 ※ 2720000	-160	20	160	122	33	42	42	42 ~ 100
3820 ※ 2730000	NBT-AHO50 or WBT-AHO50 -SRD25A -110	25	110	72	44	53	48	48 ~ 65
3820 ※ 2740000	-135	25	135	97	44	53	48	48 ~ 85
3820 ※ 2750000	-160	25	160	122	44	53	48	48 ~ 110
3820 ※ 2760000	NBT-AHO50 or WBT-AHO50 -SRD32A -110	32	110	72	44	53	52	52 ~ 65
3820 ※ 2770000	-135	32	135	97	44	53	52	52 ~ 85
3820 ※ 2780000	-160	32	160	122	44	53	52	52 ~ 110

Favor de reemplazar ※ en el código con Ø para el NBT-AHO y con 6 para el WBT-AHO.

Siempre usar herramientas de zanco de carburo con tolerancia de h6.

Please replace ※ in the code with Ø for NBT-AHO and 6 for WBT-AHO.

Always use carbide shank tools with h6 tolerance.

Tabla de dispositivos térmicos Heating device chart		
Dispositivo térmico Heating device	Portaherramienta - chuck	
	SRD6A, SRD8A	SRD10A~SRD32A
ISG3400	Sí / Yes	Sí / Yes
SRK-HA1, HB2	No	Sí / Yes

Ejemplo para Ordenar - Ordering Example

Correspondiente a nuestro zanco con contacto de doble cara BT
Corresponding to our two-face contact BT spindle

NBT-AHO40 - SRD 10 A - 105		
Interfaz y diámetro de husillo Shank size	Diámetro Interno I.D. (d)	Longitud de proyección Projection length (L)

Ejemplo para Ordenar - Ordering Example

Correspondiente a nuestro zanco con contacto de doble cara BT
Corresponding to our two-face contact BT spindle

WBT-AHO40 - SRD 10 A - 105		
Interfaz y diámetro de husillo Shank size	Diámetro Interno I.D. (d)	Longitud de proyección Projection length (L)



BT
CAT
AHO
HSK-A/E/F/C
HSK-T
C
UTS
Máquinas Especializadas
Specialized Machine
Equipo Relacionado
Related Equipment
Taladro de Biselado & de Casquillo
Bush & Chamfering Drill
Milling Chuck
Collet Holder
"R" Zero Holder
Hydraulic Chuck
Shrink Fit
Tapping Chuck
Ahoros
Function Holder
Retention Stud

※ Se necesita un tornillo de retención AHO

※ AHO Retention Stud is required.

Shrink Fit (Slim Type)

- El método de contracción coloca firmemente a una herramienta de corte al calentar y enfriar el portaherramienta. Alta precisión, rigidez y un fresado fuerte (Tipo delgado).
- Shrinkage method clamps a cutting tool firmly by heating and cooling the chuck. High precision and strong Clamping force. (Slim Type)

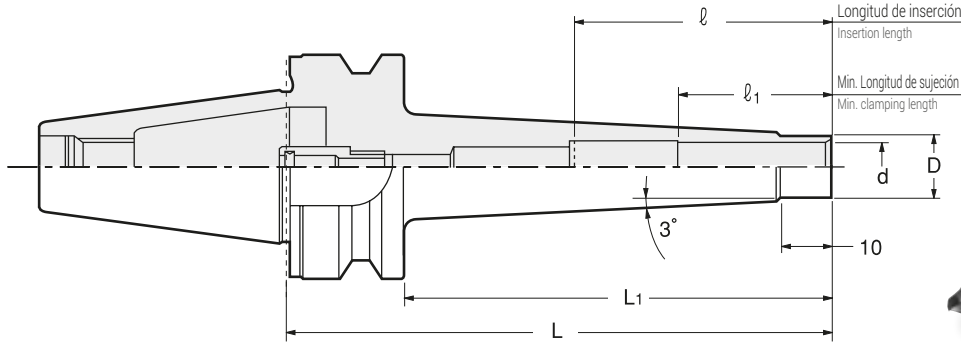

- Nuestro portaherramientas NBT de doble contacto es incompatible con el portaherramientas BT de doble contacto (para WBT-AHO). Por favor consultar pág. 50
- Cuando el modelo "AHO" es utilizado con alimentación de refrigerante que pasa a través del centro del portaherramienta, debe utilizarse un tornillo de retención diseñado para AHO (con pipa de refrigerante).
- Our two-face contact NBT spindle is incompatible with BT two-face contact spindle (for WBT-AHO). Please refer to p.50
- When AHO is used with center through coolant feeding, a designated retention stud (with coolant pipe) for AHO must be used.

Medidas Métricas – Metric Sizes

Unidad : Métrico
Unit : Metric

Código Code	Modelo Model	d	L	L1	D	ℓ1	ℓ
3820 ※ 1370000	NBT-AHO30 or WBT-AHO30 -SRS6A -105	6	105	83	9	26	26 ~ 36
3820 ※ 1380000	-135	6	135	113	9	26	26 ~ 36
3820 ※ 1390000	NBT-AHO30 or WBT-AHO30 -SRS8A -105	8	105	83	11	26	26 ~ 50
3820 ※ 1400000	-135	8	135	113	11	26	26 ~ 50
3820 ※ 1410000	NBT-AHO30 or WBT-AHO30 -SRS10A -105	10	105	83	13	32	32 ~ 50
3820 ※ 1420000	-135	10	135	113	13	32	32 ~ 50
3820 ※ 1430000	NBT-AHO30 or WBT-AHO30 -SRS12A -105	12	105	83	15	37	37 ~ 70
3820 ※ 1440000	-135	12	135	113	15	37	37 ~ 70
3820 ※ 1450000	NBT-AHO30 or WBT-AHO30 -SRS16A -105	16	105	83	20	40	40 ~ 80
3820 ※ 1460000	-135	16	135	113	20	40	40 ~ 80
3820 ※ 1010000	NBT-AHO40 or WBT-AHO40 -SRS6A -105	6	105	78	9	26	26 ~ 36
3820 ※ 1020000	-135	6	135	108	9	26	26 ~ 36
3820 ※ 1030000	NBT-AHO40 or WBT-AHO40 -SRS8A -105	8	105	78	11	26	26 ~ 50
3820 ※ 1040000	-135	8	135	108	11	26	26 ~ 50
3820 ※ 1050000	NBT-AHO40 or WBT-AHO40 -SRS10A -105	10	105	78	13	32	32 ~ 50
3820 ※ 1060000	-135	10	135	108	13	32	32 ~ 50
3820 ※ 1070000	-165	10	165	138	13	32	32 ~ 50
3820 ※ 1080000	NBT-AHO40 or WBT-AHO40 -SRS12A -105	12	105	78	15	37	37 ~ 70
3820 ※ 1090000	-135	12	135	108	15	37	37 ~ 70
3820 ※ 1100000	-165	12	165	138	15	37	37 ~ 70
3820 ※ 1110000	NBT-AHO40 or WBT-AHO40 -SRS16A -105	16	105	78	20	40	40 ~ 80
3820 ※ 1120000	-135	16	135	108	20	40	40 ~ 80
3820 ※ 1130000	-165	16	165	138	20	40	40 ~ 80
3820 ※ 1140000	NBT-AHO40 or WBT-AHO40 -SRS20A -105	20	105	78	26	42	42 ~ 85
3820 ※ 1150000	-135	20	135	108	26	42	42 ~ 100
3820 ※ 1160000	-165	20	165	138	26	42	42 ~ 100
3820 ※ 1170000	NBT-AHO50 or WBT-AHO50 -SRS6A -105	6	105	67	9	26	26 ~ 36
3820 ※ 1180000	-135	6	135	97	9	26	26 ~ 36
3820 ※ 1190000	NBT-AHO50 or WBT-AHO50 -SRS8A -105	8	105	67	11	26	26 ~ 50
3820 ※ 1200000	-135	8	135	97	11	26	26 ~ 50
3820 ※ 1210000	NBT-AHO50 or WBT-AHO50 -SRS10A -105	10	105	67	13	32	32 ~ 50
3820 ※ 1220000	-135	10	135	97	13	32	32 ~ 50
3820 ※ 1230000	-165	10	165	127	13	32	32 ~ 50
3820 ※ 1240000	-195	10	195	157	13	32	32 ~ 50

Medidas Métricas – Metric Sizes Unidad : Métrico
Unit : Metric

Código Code	Modelo Model	d	L	L1	D	ℓ1	ℓ
3820 ※ 1250000	NBT-AHO50 or WBT-AHO50 -SRS12A -105	12	105	67	15	37	37 ~ 70
3820 ※ 1260000	-135	12	135	97	15	37	37 ~ 70
3820 ※ 1270000	-165	12	165	127	15	37	37 ~ 70
3820 ※ 1280000	-195	12	195	157	15	37	37 ~ 70
3820 ※ 1290000	NBT-AHO50 or WBT-AHO50 -SRS16A -105	16	105	67	20	40	40 ~ 80
3820 ※ 1300000	-135	16	135	97	20	40	40 ~ 80
3820 ※ 1310000	-165	16	165	127	20	40	40 ~ 80
3820 ※ 1320000	-195	16	195	157	20	40	40 ~ 80
3820 ※ 1330000	NBT-AHO50 or WBT-AHO50 -SRS20A -105	20	105	67	26	42	42 ~ 85
3820 ※ 1340000	-135	20	135	97	26	42	42 ~ 100
3820 ※ 1350000	-165	20	165	127	26	42	42 ~ 100
3820 ※ 1360000	-195	20	195	157	26	42	42 ~ 100

Favor de reemplazar ※ en el código con Ø para el NBT-AHO y con 6 para el WBT-AHO.

Siempre usar herramientas de zanco de carburo con tolerancia de h6.

Please replace ※ in the code with 0 for NBT-AHO and 6 for WBT-AHO.

Always use carbide shank tools with h6 tolerance.

Tabla de dispositivos térmicos Heating device chart		
Dispositivo térmico Heating device	Portaherramienta - chuck	
	SRS6A, SRS8A	SRS10A~SRS20A
ISG3400	Sí / Yes	Sí / Yes
SRK-HA1, HB2	No	Sí / Yes

Ejemplo para Ordenar - Ordering Example

Correspondiente a nuestro zanco con contacto de doble cara BT
Corresponding to our two-face contact BT spindle

NBT-AHO40	- SRS	12	A	-	105
Interfaz y diámetro de husillo Shank size		Diámetro Interno I.D. (d)			Longitud de proyección Projection length (L)

Ejemplo para Ordenar - Ordering Example

Correspondiente al zanco con contacto de doble cara BT
Corresponding to BT two-face contact spindle

WBT-AHO40	- SRS	12	A	-	105
Interfaz y diámetro de husillo Shank size		Diámetro Interno I.D. (d)			Longitud de proyección Projection length (L)

- BT
- CAT
- AHO**
- HSK-A/E/F/C
- HSK-T
- C
- UTS
- Máquinas Especializadas
Specialized Machine
- Equipo Relacionado
Related Equipment
- Taladro de Biselado & de Casquillo
Bush & Chamfering Drill
- Milling Chuck
- Collet Holder
- "R" Zero Holder
- Hydraulic Chuck
- Shrink Fit
- Tapping Chuck
- Arbors
- Function Holder
- Retention Stud



※ Se necesita un tornillo de retención AHO

※ AHO Retention Stud is required.

Synchronous Tap Holder With Easy Tool Length Adjustment

- La longitud de proyección de la herramienta de corte se puede ajustar simplemente girando la circunferencia del portaherramienta.
- Projection length of the cutting tool can be adjusted by simply turning circumference of the holder.



Para conocer las medidas adecuadas de machuelo, consulte la tabla en la pág. 485-486.

(NOTA) El D.E. de la tuerca del STM8 es de 19 mm.

For capable tap sizes, please refer to P.485-486 chart.

(NOTE) Nut O.D. of STM8 is 19mm.

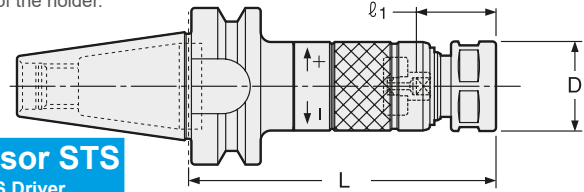

Portaherramienta STM
STM Holder

Boquilla
Collet

Impulsor STS
STS Driver



• Nuestro portaherramientas NBT de doble contacto es incompatible con el portaherramientas BT de doble contacto (para WBT-AHO). Por favor consultar pág. 50

• Cuando el modelo "AHO" es utilizado con alimentación de refrigerante que pasa a través del centro del portaherramienta, debe utilizarse un tornillo de retención diseñado para AHO (con pipa de refrigerante).

• Our two-face contact NBT spindle is incompatible with BT two-face contact spindle (for WBT-AHO). Please refer to p.50

• When AHO is used with center through coolant feeding, a designated retention stud (with coolant pipe) for AHO must be used.

Unidad : Métrico
Unit : Metric

Código Code	Modelo Model	Medida de machuelo Tap Size	L	D	Tuerca ciega Nut	Boquilla Collet	Unidad preajustada Preset Driver	Llave Inglesa Spanner			
3740 ※ 0010000	NBT-AHO30 or WBT-AHO30 -STM8 -75 *		75	21	KDP-1414	FDC-07	STS-8	Llave con 17 mm de ancho (Flat 17mm width)			
3740 ※ 0020000	-90	Old JIS Taps M4 ~ 8	90	21	KDP-1414						
3740 ※ 0030000	-105	U No8 ~ 5/16	105	21	KDP-1414						
3740 ※ 0040000	-120		120	21	KDP-1414						
3740 ※ 0050000	-135	OSG Synchro Taps M4 ~ 6	135	21	KDP-1414						
3740 ※ 0060000	-150		150	21	KDP-1414						
3740 ※ 0070000	NBT-AHO30 or WBT-AHO30 -STM12-75 *		75	26	HTP-09	FSC-09	STS-12	S-1L			
3740 ※ 0080000	-90	Old JIS Taps M4 ~ 12	90	26	HTP-09						
3740 ※ 0090000	-105	U No8 ~ 7/16 PT1/8	105	26	HTP-09						
3740 ※ 0100000	-120		120	26	HTP-09						
3740 ※ 0110000	-135	OSG Synchro Taps M4 ~ 10	135	26	HTP-09						
3740 ※ 0120000	-150		150	26	HTP-09						
3740 ※ 0130000	-165		165	26	HTP-09						
3740 ※ 0140000	NBT-AHO30 or WBT-AHO30 -STM18-90		90	36	HTP-16	FSC-16	STS-18	S-4L			
3740 ※ 0150000	-105	Old JIS Taps M14 ~ 18	105	36	HTP-16						
3740 ※ 0160000	-120	U1/2 ~ 3/4 PT1/4 ~ 3/8	120	36	HTP-16						
3740 ※ 0170000	-135		135	36	HTP-16						
3740 ※ 0180000	-150	OSG Synchro Taps M12 ~ 14	150	36	HTP-16						
3740 ※ 0190000	-165		165	36	HTP-16						
3740 ※ 0200000	NBT-AHO30 or WBT-AHO30 -STM30-105		105	46	HTP-22	FSC-22	STS-30	S-5L			
3740 ※ 0210000	-120	Old JIS Taps M20 ~ 30	120	46	HTP-22						
3740 ※ 0220000	-135	U7/8 ~ 1-1/8 PT1/2 ~ 3/4	135	46	HTP-22						
3740 ※ 0230000	-150	OSG Synchro Taps M16 ~ 27	150	46	HTP-22						
3740 ※ 0240000	-165		165	46	HTP-22						
3740 ※ 0250000	NBT-AHO40 or WBT-AHO40 -STM8 -90		90	21	KDP-1414	FDC-07	STS-8	Llave con 17 mm de ancho (Flat 17mm width)			
3740 ※ 0260000	-105	Old JIS Taps M4 ~ 8	105	21	KDP-1414						
3740 ※ 0270000	-120	U No8 ~ 5/16	120	21	KDP-1414						
3740 ※ 0280000	-135		135	21	KDP-1414						
3740 ※ 0290000	-150	OSG Synchro Taps M4 ~ 6	150	21	KDP-1414						
3740 ※ 0300000	NBT-AHO40 or WBT-AHO40 -STM12-90		90	26	HTP-09	FSC-09	STS-12	S-1L			
3740 ※ 0310000	-105	Old JIS Taps M4 ~ 12	105	26	HTP-09						
3740 ※ 0320000	-120	U No8 ~ 7/16 PT1/8	120	26	HTP-09						
3740 ※ 0330000	-135		135	26	HTP-09						
3740 ※ 0340000	-150	OSG Synchro Taps M4 ~ 10	150	26	HTP-09						
3740 ※ 0350000	-180		180	26	HTP-09						
3740 ※ 0360000	NBT-AHO40 or WBT-AHO40 -STM18-105		105	36	HTP-16	FSC-16	STS-18	S-4L			
3740 ※ 0370000	-120	Old JIS Taps M14 ~ 18	120	36	HTP-16						
3740 ※ 0380000	-135	U1/2 ~ 3/4 PT1/4 ~ 3/8	135	36	HTP-16						
3740 ※ 0390000	-150	OSG Synchro Taps M12 ~ 14	150	36	HTP-16						
3740 ※ 0400000	-180		180	36	HTP-16						
3740 ※ 0410000	NBT-AHO40 or WBT-AHO40 -STM30-120		120	46	HTP-22	FSC-22	STS-30	S-5L			
3740 ※ 0420000	-135	Old JIS Taps M20 ~ 30	135	46	HTP-22						
3740 ※ 0430000	-150	U7/8 ~ 1-1/8 PT1/2 ~ 3/4	150	46	HTP-22						
3740 ※ 0440000	-180	OSG Synchro Taps M16 ~ 27	180	46	HTP-22						
3740 ※ 0450000	NBT-AHO50 or WBT-AHO50 -STM8 -90 *		90	21	KDP-1414				FDC-07	STS-8	Llave con 17 mm de ancho (Flat 17mm width)
3740 ※ 0460000	-105	Old JIS Taps M4 ~ 8	105	21	KDP-1414						
3740 ※ 0470000	-120	U No8 ~ 5/16	120	21	KDP-1414						
3740 ※ 0480000	-135		135	21	KDP-1414						
3740 ※ 0490000	-150	OSG Synchro Taps M4 ~ 6	150	21	KDP-1414						
3740 ※ 0500000	-165		165	21	KDP-1414						
3740 ※ 0510000	NBT-AHO50 or WBT-AHO50 -STM12-90 *		90	26	HTP-09	FSC-09	STS-12	S-1L			
3740 ※ 0520000	-105	Old JIS Taps M4 ~ 12	105	26	HTP-09						
3740 ※ 0530000	-120	U No8 ~ 7/16 PT1/8	120	26	HTP-09						
3740 ※ 0540000	-135		135	26	HTP-09						
3740 ※ 0550000	-150	OSG Synchro Taps M4 ~ 10	150	26	HTP-09						
3740 ※ 0560000	-180		180	26	HTP-09						

Código Code	Modelo Model	Medida de machuelo Tap Size	L	D	Tuerca ciega Nut	Boquilla Collet	Unidad preajustada Preset Driver	Llave Inglesa Spanner
3740 ※ 0570000	NBT-AHO50 or WBT-AHO50 -STM18-105	Old JIS Taps M14 ~ 18	105	36	HTP-16	FSC-16	STS-18	S-4L
3740 ※ 0580000		-120	120	36	HTP-16			
3740 ※ 0590000		-135	135	36	HTP-16			
3740 ※ 0600000		-150	150	36	HTP-16			
3740 ※ 0610000		-180	180	36	HTP-16			
3740 ※ 0620000	NBT-AHO50 or WBT-AHO50 -STM30-120	Old JIS Taps M20 ~ 30	120	46	HTP-22	FSC-22	STS-30	S-5L
3740 ※ 0630000		-135	135	46	HTP-22			
3740 ※ 0640000		-150	150	46	HTP-22			
3740 ※ 0650000		-180	180	46	HTP-22			
3740 ※ 0660000		-210	210	46	HTP-22			

Favor de reemplazar ※ en el código con Ø para el NBT-AHO y con 6 para el WBT-AHO.

- La boquilla, la llave inglesa y la unidad preajustada se venden por separado.
- Favor de ver a continuación para conocer la dimensión ℓ1.
- El STM8 puede hacer orificios de machuelo menores a M4. Las boquillas a usar son como se especifica a continuación. M1-M2.6: FDC-03007-※※ M3-M3.5: FDC-04007-※※ La boquilla del machuelo no se usará para los usos antes mencionados.

Please replace ※ in the code with Ø for NBT-AHO and 6 for WBT-AHO.

- Collet, spanner and preset driver are sold separately.
- Please see below for ℓ1 dimension.
- Tap holes smaller than M4 can be made by STM8. Collets to be used are as follows. M1-M2.6: FDC-03007-※※ M3-M3.5: FDC-04007-※※ Tap drive will not be used for the above usages.

Boquilla Collet
Pág.276



Tornillo de preajuste Preset screw
Pág.276-277



Ejemplo para Ordenar - Ordering Example

Correspondiente a nuestro zanco con contacto de doble cara BT
Corresponding to our two-face contact BT spindle

NBT-AHO40	- STM	18	-	120
Interfaz y diámetro de husillo Shank size		Medida de portaherramienta Holder size		Longitud de proyección Projection length (L)

Ejemplo para Ordenar - Ordering Example

Correspondiente al zanco con contacto de doble cara BT
Corresponding to BT two-face contact spindle

WBT-AHO40	- STM	18	-	120
Interfaz y diámetro de husillo Shank size		Medida de portaherramienta Holder size		Longitud de proyección Projection length (L)

STM Dimensiones para ℓ1 - ℓ1 Dimension for STM

Machuelos JIS antiguas - Old JIS Taps

Sin vena de refrigerante a través del centro - Without center-through coolant			Con vena de refrigerante a través del centro - With center-through coolant (STM12~30)		
Medida de machuelo - Tap Size	ℓ1	ℓ1(※)	Medida de machuelo - Tap Size	ℓ1	ℓ1(※)
M4 ~ 6 U No.8 ~ 1/4	21 ~ 35	21 ~ 26	M4 ~ 6 U No.8 ~ 1/4	24 ~ 35	24 ~ 26
M7 ~ 12 U 5/16 ~ U7/16 PT1/8	23 ~ 37	23 ~ 28	M7 ~ 10 U 5/16 ~ 3/8 M11 ~ 12 U 7/16 PT 1/8	25 ~ 37	25 ~ 28
M13 ~ 15 U 1/2 ~ 5/8 PT1/4	28 ~ 42	-	U1/2	32 ~ 42	-
M16 ~ 17	32 ~ 45	-	M13 ~ 15 U9/16	33 ~ 42	-
M18 ~ 27 U 3/4 ~ U1 PT3/8 ~ 5/8	33 ~ 47	-	U5/8 PT1/4	34 ~ 42	-
M30 U1-1/8 PT3/4	38 ~ 52	-	M16	35 ~ 46	-
			M18	36 ~ 47	-
			U 3/4 PT3/8		
			M20 ~ 21 PT1/2	40 ~ 47	-
			M22	41 ~ 47	-
			U 7/8	42 ~ 47	-
			M23	42 ~ 47	-
			M24 ~ 25 PT5/8	43 ~ 47	-
			M26 ~ 27 U1	44 ~ 47	-
			M28	45 ~ 52	-
			M30	46 ~ 52	-
			PT3/4		
			U 1-1/8	48 ~ 52	-

Machuelos sincronizados OSG - OSG Synchro Taps

Sin vena refrigerante a través del centro - Without center-through coolant			Con vena de refrigerante a través del centro - With center-through coolant (STM8)			Con vena de refrigerante a través del centro - With center-through coolant (STM12~30)		
Medida de machuelo - Tap Size	ℓ1	ℓ1(※)	Medida de machuelo - Tap Size	ℓ1	ℓ1(※)	Medida de machuelo - Tap Size	ℓ1	ℓ1(※)
M4 ~ 6	21 ~ 35	21 ~ 26	M4 ~ 6	25 ~ 35	25 ~ 26	M4 ~ 6	24 ~ 35	24 ~ 26
M8 ~ 10	23 ~ 37	23 ~ 28				M8 ~ 10	26 ~ 37	26 ~ 28
M12 ~ 14	28 ~ 42	-				M12	33 ~ 42	-
M16 ~ 27	33 ~ 47	-				M14	34 ~ 42	-
						M16 ~ 20	40 ~ 46	-
						M22 ~ 27	44 ~ 47	-

YAMAWA X Series

Sin vena de refrigerante a través del centro - Without center-through coolant			Con vena de refrigerante a través del centro - With center-through coolant (STM8)			Con vena de refrigerante a través del centro - With center-through coolant (STM12~30)		
Medida de machuelo - Tap Size	ℓ1	ℓ1(※)	Medida de machuelo - Tap Size	ℓ1	ℓ1(※)	Medida de machuelo - Tap Size	ℓ1	ℓ1(※)
M6 M8	23 ~ 37	23 ~ 28	M6	26 ~ 37	26 ~ 28	M6	25 ~ 37	25 ~ 28
M10 M12	28 ~ 42	-				M8	26 ~ 37	26 ~ 28
						M10	33 ~ 42	-
						M12	34 ~ 42	-



Tabla de referencia de las medidas de machuelo (boquilla, conductor de preajuste)

Tap size reference chart (collet, preset driver)

FDC 07 ó/ or FSC - boquilla (collet)

Unidad de cambio del conductor de preajuste y herramienta preset driver & tool for changing driver

Tipo OH - Type OH

● La boquilla OH debe usarse para el abastecimiento de refrigerante a través del centro y para el abastecimiento de refrigerante externo.

● OH type collet should be used for center-through coolant feeding and external coolant feeding.

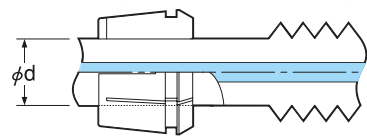

Tipo C - Type C

● Cuando se necesita el abastecimiento de refrigerante "a través de la boquilla"

● when "collet-through" coolant feeding is needed.

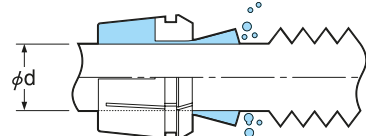

Tipo STS - Type STS

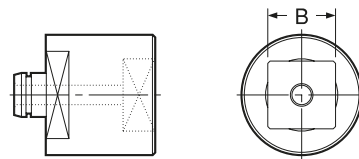

Tipo STS-R - Type STS



Favor de elegir el tipo OH para un uso sin refrigerante. Please select OH type for non-coolant use.

Modelo de Portaherramienta Holder Model	Medida de machuelo - Tap Size				YAMAWA X Series	ød	Modelo de Boquilla Collet Model (OH or C)	B	Conductor de preajuste Preset Driver	Herramienta para cambiar el conductor preajustado - Tool for Changing Driver
	Rosca métrica - Metric Thread	Rosca unificada - Unified Thread	Rosca de tubo Machuelo - Pipe Taper Thread	Machuelos de roscar sincronizados de OSG - OSG Synchro-Taps						
STM8	M4~M4.5	UNo.8				5.0 FDC-05007-**	4.0	STS8-□4.0	STS-R0	
	M5~M5.5	UNo.10~12				5.5 FDC-05507-**	4.5	STS8-□4.5	STS-R0	
	M6	U1/4		M4~M6		6.0 FDC-06007-**	4.5	STS8-□4.5	STS-R0	
		U5/16			M6	6.0 FDC-06007-**	4.9	STS8-□4.9	STS-R0	
						6.1 FDC-06107-**	5.0	STS8-□5.0	STS-R0	
		M7~8				6.2 FDC-06207-**	5.0	STS8-□5.0	STS-R0	
STM12	M4~M4.5	UNo.8				5.0 FSC-09-5.0-**	4.0	STS12-□4.0	STS-R1	
	M5~M5.5	UNo.10~12				5.5 FSC-09-5.5-**	4.5	STS12-□4.5	STS-R1	
	M6	U1/4		M4~M6		6.0 FSC-09-6.0-**	4.5	STS12-□4.5	STS-R1	
		U5/16			M6	6.0 FSC-09-6.0-**	4.9	STS12-□4.9	STS-R1	
						6.1 FSC-09-6.1-**	5.0	STS12-□5.0	STS-R1	
		M7~8				6.2 FSC-09-6.2-**	5.0	STS12-□5.0	STS-R1	
		M9~M10	U3/8			7.0 FSC-09-7.0-**	5.5	STS12-□5.5	STS-R1	
					M8	8.0 FSC-09-8.0-**	6.2	STS12-□6.2	STS-R1	
		M11	U7/16	PT1/16~1/8	M8~M10	8.0 FSC-09-8.0-**	6.0	STS12-□6.0	STS-R1	
		M12				8.5 FSC-09-8.5-**	6.5	STS12-□6.5	STS-R1	
STM18		U1/2				9.0 FSC-16-9.0-**	7.0	STS18-□7.0	STS-R2	
	M13					9.5 FSC-16-9.5-**	7.0	STS18-□7.0	STS-R2	
				M12	M10	10.0 FSC-16-10.0-**	8.0	STS18-□8.0	STS-R2	
	M14~15	U9/16				10.5 FSC-16-10.5-**	8.0	STS18-□8.0	STS-R2	
			PT1/4			11.0 FSC-16-11.0-**	9.0	STS18-□9.0	STS-R2	
		U5/8		M14	M12	12.0 FSC-16-12.0-**	9.0	STS18-□9.0	STS-R2	
						12.5 FSC-16-12.5-**	10.0	STS18-□10.0	STS-R2	
		M16				13.0 FSC-16-13.0-**	10.0	STS18-□10.0	STS-R2	
		M17				14.0 FSC-16-14.0-**	11.0	STS18-□11.0	STS-R2	
		M18~M19	U3/4	PT3/8		15.0 FSC-22-15.0-**	12.0	STS30-□12.0	STS-R2	
STM30	M20					16.0 FSC-22-16.0-**	12.0	STS30-□12.0	STS-R2	
	M21			M16~M20		17.0 FSC-22-17.0-**	13.0	STS30-□13.0	STS-R2	
	M22	U7/8				18.0 FSC-22-18.0-**	14.0	STS30-□14.0	STS-R2	
	M23		PT1/2			19.0 FSC-22-19.0-**	15.0	STS30-□15.0	STS-R2	
	M24~M25		PT5/8			20.0 FSC-22-20.0-**	15.0	STS30-□15.0	STS-R2	
	M26~M27	U1		M22~M27		21.0 FSC-22-21.0-**	17.0	STS30-□17.0	STS-R2	
	M28					22.0 FSC-22-22.0-**	17.0	STS30-□17.0	STS-R2	
		U1-1/8				23.0 FSC-22-23.0-**	17.0	STS30-□17.0	STS-R2	

Ejemplo para Ordenar - Ordering Example

FSC - 22 - 20.0 - OH

Medida de la boquilla

Collet size

D.I. de la boquilla

Collet I.D. (d)

OH: Para herramienta con vena de refrigerante

C: Para refrigerante a través de los costados de la boquilla

OH: For tool with coolant hole

C: For collet through

Combinación de accesorios - Accessories combination

Portaherramienta para machuelo - Tap holder	Boquilla Collet	Conductor de preajuste Preset driver		Tuerca ciega Nut		Unidad de cambio de herramienta - Tool changing driver		Llave Inglesa Spanner	
Modelo Model	Modelo Model	Modelo Model	Código Code	Modelo Model	Código Code	Modelo Model	Código Code	Modelo Model	Código Code
STM8	FDC-07	STS8	3914 0100**03	KDP-1414	0070 01001407	STS-R0	3914 00000006	Llave con 17 mm de ancho (Flat 17mm width)	
STM12	FSC-09	STS12	3914 1100**03	HTP-09	1314 00000009	STS-R1	3914 10000006	S-1L	0803 00000011
STM18	FSC-16	STS18	3914 310**03	HTP-16	1314 00000016	STS-R2	3914 30000006	S-4L	0803 00000014
STM30	FSC-22	STS30	3914 410**03	HTP-22	1314 00000022	STS-R2	3914 30000006	S-5L	0803 00000015

Tabla de referencia de las medidas de machuelo (boquilla, conductor de preajuste)

Tap size reference chart (collet, preset driver)

FDC 07 ó/or FSC - boquilla (collet)

Unidad de cambio del conductor de preajuste y herramienta
preset driver & tool for changing driver

Tipo OH - Type OH

● La boquilla OH debe usarse para el abastecimiento de refrigerante a través del centro y para el abastecimiento de refrigerante externo.
● OH type collet should be used for center-through coolant feeding and external coolant feeding.

Tipo C - Type C

● Cuando se necesita el abastecimiento de refrigerante "a través de la boquilla"
● when "collet-through" coolant feeding is needed.

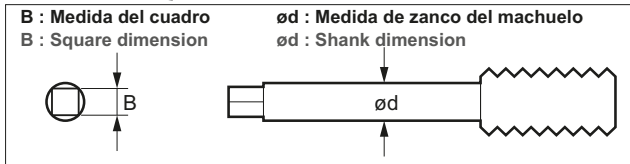
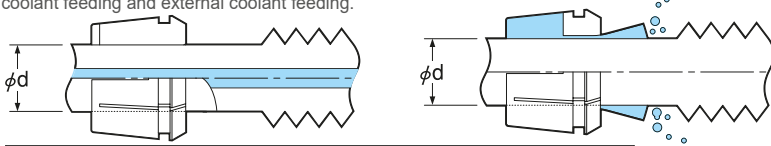

Favor de elegir el tipo OH para un uso sin refrigerante.
Please select OH type for non-coolant use.

Tipo STS - Type STS

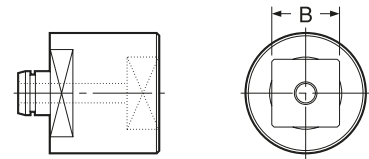

Tipo STS-R - Type STS

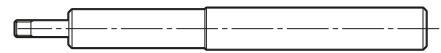

Modelo de Portaherramienta Holder Model	Medida de machuelo Tap Size (ANSI)	ød (pulgadas - inch)	ød (mm)	Modelo de Boquilla Collet Model (OH or C)	B (inch)	B (mm)	Conductor de preajuste Preset Driver
STM8	#0-6	0.141	3.5814	FDC-03607**	0.110	2.794	STS8- □ 2.8
	#8	0.168	4.2672	FDC-04307**	0.131	3.3274	STS8- □ 3.4
	#10	0.194	4.9276	FDC-05007**	0.152	3.8608	STS8- □ 4.0
	#12	0.22	5.588	FDC-05607**	0.165	4.191	STS8- □ 4.2
	1/4	0.255	6.477	FDC-06507**	0.191	4.8514	STS8- □ 5.0
STM12	#0-6	0.141	3.5814	FSC-09-3.6**	0.110	2.794	STS12- □ 2.8
	#8	0.168	4.2672	FSC-09-4.3**	0.131	3.3274	STS12- □ 3.4
	#10	0.194	4.9276	FSC-09-5.0**	0.152	3.8608	STS12- □ 4.0
	#12	0.22	5.588	FSC-09-5.6**	0.165	4.191	STS12- □ 4.2
	1/4	0.255	6.477	FSC-09-6.5**	0.191	4.8514	STS12- □ 5.0
	1/8SPT	0.313	7.9502	FSC-09-8.0**	0.234	5.9436	STS12- □ 6.0
	5/16	0.318	8.0772	FSC-09-8.1**	0.238	6.0452	STS12- □ 6.1
STM18	7/16	0.323	8.2042	FSC-09-8.3**	0.242	6.1468	STS12- □ 6.2
	1/2	0.367	9.3218	FSC-16-9.4**	0.275	6.985	STS18- □ 7.0
	3/8	0.381	9.6774	FSC-16-9.7**	0.286	7.2644	STS18- □ 7.3
	9/16	0.429	10.8966	FSC-16-10.9**	0.322	8.1788	STS18- □ 8.2
	1/8LPT	0.437	11.0998	FSC-16-11.1**	0.328	8.3312	STS18- □ 8.4
	5/8	0.48	12.192	FSC-16-12.2**	0.360	9.144	STS18- □ 9.2
	11/16	0.542	13.7668	FSC-16-13.8**	0.406	10.3124	STS18- □ 10.4
STM30	1/4PT	0.562	14.2748	FSC-16-14.3**	0.421	10.6934	STS18- □ 10.7
	3/4	0.59	14.986	FSC-22-15.0**	0.442	11.2268	STS30- □ 11.3
	13/16	0.652	16.5608	FSC-22-16.6**	0.489	12.4206	STS30- □ 12.5
	7/8	0.697	17.7038	FSC-22-17.8**	0.523	13.2842	STS30- □ 13.3
	3/8PT	0.7	17.78	FSC-22-17.8**	0.531	13.4874	STS30- □ 13.5
	1	0.8	20.32	FSC-22-20.4**	0.600	15.24	STS30- □ 15.3

Para DIN e ISO, favor de dirigirse a la pág. 485-486.
For DIN and ISO, please refer to P. 485-86.

Ejemplo para Ordenar - Ordering Example

FSC - 22 - 20.4 - OH

Medida de la boquilla
Collet size

D.I. de la boquilla
Collet I.D. (d)

OH: Para herramienta con vena de refrigerante

C: Para refrigerante a través de los costados de la boquilla

OH: For tool with coolant hole

C: For collet through

Combinación de accesorios - Accessories combination

Portaherramienta para machuelo - Tap holder	Boquilla Collet	Conductor de preajuste Preset driver		Tuerca ciega Nut		Unidad de cambio de herramienta Tool changing driver		Llave Inglesa Spanner	
Modelo Model	Modelo Model	Modelo Model	Código Code	Modelo Model	Código Code	Modelo Model	Código Code	Modelo Model	Código Code
STM8	FDC-07	STS8	3914 0100**03	KDP-1414	0070 01001407	STS-R0	3914 00000006	Llave con 17 mm de ancho (Flat 17mm width)	
STM12	FSC-09	STS12	3914 1100**03	HTP-09	1314 00000009	STS-R1	3914 10000006	S-1L	0803 00000011
STM18	FSC-16	STS18	3914 310***03	HTP-16	1314 00000016	STS-R2	3914 30000006	S-4L	0803 00000014
STM30	FSC-22	STS30	3914 410***03	HTP-22	1314 00000022	STS-R2	3914 30000006	S-5L	0803 00000015

BT
CAT
AHO
HSK-A/E/F/C
HSK-T
C
UTS
Máquinas Especializadas
Specialized Machine
Equipo Relacionado
Related Equipment
Taladro de Biselado & de Casquillo
Bush & Chamfering Drill

Milling Chuck

Collet Holder

"R" Zero Holder

Hydraulic Chuck

Shrink Fit

Tapping Chuck

Abrors

Function Holder

Retention Stud

Boquilla para machuelo - Collet For Tapper

FSC-OH

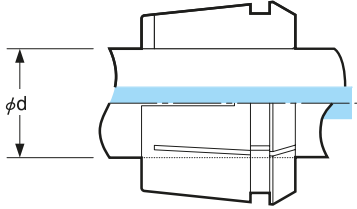
Para herramienta con vena para refrigerante
For tool with coolant hole

FSC-C

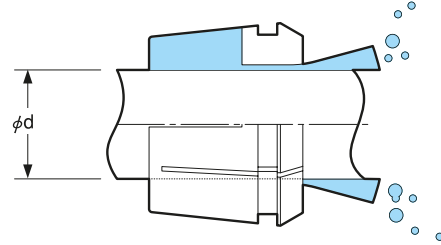
Para refrigerante a través de los costados
For Collet through

Diá. del zanco de la herramienta -Tool Shank Dia.		Medida Size	Código Code
ød (inch)	ød (mm)		
ø 0.141	ø 3.6	FSC-09-3.6-OH	—
ø 0.168	ø 4.3	FSC-09-4.3-OH	1334 00104309
ø 0.194	ø 5.0	FSC-09-5.0-OH	1334 00105009
ø 0.220	ø 5.6	FSC-09-5.6-OH	1334 00105609
ø 0.216	ø 5.5	FSC-09-5.5-OH	1334 00105509
ø 0.236	ø 6.0	FSC-09-6.0-OH	1334 00106009
ø 0.240	ø 6.1	FSC-09-6.1-OH	1334 00106109
ø 0.244	ø 6.2	FSC-09-6.2-OH	1334 00106209
ø 0.255	ø 6.5	FSC-09-6.5-OH	1334 00106509
ø 0.275	ø 7.0	FSC-09-7.0-OH	1334 00107009
ø 0.314	ø 8.0	FSC-09-8.0-OH	1334 00108009
ø 0.313	ø 8.0	FSC-09-8.0-OH	1334 00108009
ø 0.318	ø 8.1	FSC-09-8.1-OH	1334 00108109
ø 0.323	ø 8.3	FSC-09-8.3-OH	1334 00108309
ø 0.334	ø 8.5	FSC-09-8.5-OH	1334 00108509
ø 0.354	ø 9.0	FSC-16-9.0-OH	1334 00109016
ø 0.367	ø 9.4	FSC-16-9.4-OH	1334 00109416
ø 0.374	ø 9.5	FSC-16-9.5-OH	1334 00109516
ø 0.381	ø 9.7	FSC-16-9.7-OH	1334 00109716
ø 0.393	ø 10.0	FSC-16-10.0-OH	1334 00110016
ø 0.413	ø 10.5	FSC-16-10.5-OH	1334 00110516
ø 0.429	ø 10.9	FSC-16-10.9-OH	1334 00110916
ø 0.433	ø 11.0	FSC-16-11.0-OH	1334 00111016
ø 0.437	ø 11.1	FSC-16-11.1-OH	1334 00111116
ø 0.472	ø 12.0	FSC-16-12.0-OH	1334 00112016
ø 0.480	ø 12.2	FSC-16-12.2-OH	1334 00112216
ø 0.492	ø 12.5	FSC-16-12.5-OH	1334 00112516
ø 0.511	ø 13.0	FSC-16-13.0-OH	1334 00113016
ø 0.542	ø 13.8	FSC-16-13.8-OH	1334 00113816
ø 0.551	ø 14.0	FSC-16-14.0-OH	1334 00114016
ø 0.562	ø 14.3	FSC-16-14.3-OH	1334 00114316
ø 0.590	ø 15.0	FSC-22-15.0-OH	1334 00115022
ø 0.629	ø 16.0	FSC-22-16.0-OH	1334 00116022
ø 0.652	ø 16.6	FSC-22-16.6-OH	1334 00116622
ø 0.669	ø 17.0	FSC-22-17.0-OH	1334 00117022
ø 0.697	ø 17.8	FSC-22-17.8-OH	1334 00117822
ø 0.700	ø 17.8	FSC-22-17.8-OH	1334 00117822
ø 0.708	ø 18.0	FSC-22-18.0-OH	1334 00118022
ø 0.748	ø 19.0	FSC-22-19.0-OH	1334 00119022
ø 0.800	ø 20.4	FSC-22-20.4-OH	1334 00120422
ø 0.787	ø 20.0	FSC-22-20.0-OH	1334 00120022
ø 0.826	ø 21.0	FSC-22-21.0-OH	1334 00121022
ø 0.866	ø 22.0	FSC-22-22.0-OH	1334 00122022
ø 0.905	ø 23.0	FSC-22-23.0-OH	1334 00123022

Diá. del zanco de la herramienta -Tool Shank Dia.		Medida Size	Código Code
ød (inch)	ød (mm)		
ø 0.141	ø 3.6	FSC-09-3.6-C	—
ø 0.168	ø 4.3	FSC-09-4.3-C	1335 00104309
ø 0.194	ø 5.0	FSC-09-5.0-C	1335 00105009
ø 0.220	ø 5.6	FSC-09-5.6-C	1335 00105609
ø 0.216	ø 5.5	FSC-09-5.5-C	1335 00105509
ø 0.236	ø 6.0	FSC-09-6.0-C	1335 00106009
ø 0.240	ø 6.1	FSC-09-6.1-C	1335 00106109
ø 0.244	ø 6.2	FSC-09-6.2-C	1335 00106209
ø 0.255	ø 6.5	FSC-09-6.5-C	1335 00106509
ø 0.275	ø 7.0	FSC-09-7.0-C	1335 00107009
ø 0.314	ø 8.0	FSC-09-8.0-C	1335 00108009
ø 0.313	ø 8.0	FSC-09-8.0-C	1335 00108009
ø 0.318	ø 8.1	FSC-09-8.1-C	1335 00108109
ø 0.323	ø 8.3	FSC-09-8.3-C	1335 00108309
ø 0.334	ø 8.5	FSC-09-8.5-C	1335 00108509
ø 0.354	ø 9.0	FSC-16-9.0-C	1335 00109016
ø 0.367	ø 9.4	FSC-16-9.4-C	1335 00109416
ø 0.374	ø 9.5	FSC-16-9.5-C	1335 00109516
ø 0.381	ø 9.7	FSC-16-9.7-C	1335 00109716
ø 0.393	ø 10.0	FSC-16-10.0-C	1335 00110016
ø 0.413	ø 10.5	FSC-16-10.5-C	1335 00110516
ø 0.429	ø 10.9	FSC-16-10.9-C	1335 00110916
ø 0.433	ø 11.0	FSC-16-11.0-C	1335 00111016
ø 0.437	ø 11.1	FSC-16-11.1-C	1335 00111116
ø 0.472	ø 12.0	FSC-16-12.0-C	1335 00112016
ø 0.480	ø 12.2	FSC-16-12.2-C	1335 00112216
ø 0.492	ø 12.5	FSC-16-12.5-C	1335 00112516
ø 0.511	ø 13.0	FSC-16-13.0-C	1335 00113016
ø 0.542	ø 13.8	FSC-16-13.8-C	1335 00113816
ø 0.551	ø 14.0	FSC-16-14.0-C	1335 00114016
ø 0.562	ø 14.3	FSC-16-14.3-C	1335 00114316
ø 0.590	ø 15.0	FSC-22-15.0-C	1335 00115022
ø 0.629	ø 16.0	FSC-22-16.0-C	1335 00116022
ø 0.652	ø 16.6	FSC-22-16.6-C	1335 00116622
ø 0.669	ø 17.0	FSC-22-17.0-C	1335 00117022
ø 0.697	ø 17.8	FSC-22-17.8-C	1335 00117822
ø 0.700	ø 17.8	FSC-22-17.8-C	1335 00117822
ø 0.708	ø 18.0	FSC-22-18.0-C	1335 00118022
ø 0.748	ø 19.0	FSC-22-19.0-C	1335 00119022
ø 0.800	ø 20.4	FSC-22-20.4-C	1335 00120422
ø 0.787	ø 20.0	FSC-22-20.0-C	1335 00120022
ø 0.826	ø 21.0	FSC-22-21.0-C	1335 00121022
ø 0.866	ø 22.0	FSC-22-22.0-C	1335 00122022
ø 0.905	ø 23.0	FSC-22-23.0-C	1335 00123022

Se deberá elegir el tipo OH en caso de que no se use el refrigerante desde el husillo de la máquina.
OH type shall be selected in case not utilizing coolant through from the machine spindle.

Ejemplo para Ordenar - Ordering Example

FSC - 16 - 9.0 - OH
Series 16 Diá. del zanco de la herramienta
16 Series Tool Shank Dia.

Ejemplo para Ordenar - Ordering Example

FSC - 16 - 9.0 - C
Series 16 Diá. del zanco de la herramienta
16 Series Tool Shank Dia.

NOTAS

Morse Taper Holder

- Para el portaherramienta zanco Morse con espiga
- For Morse taper shank with tang.

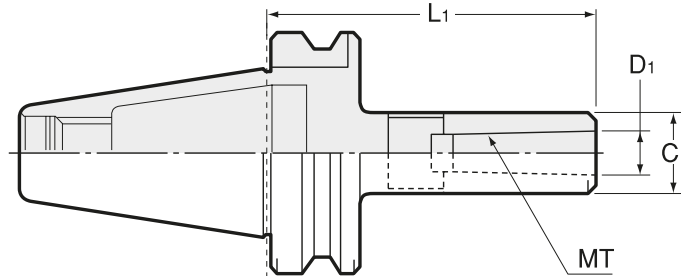

- Nuestros portaherramientas NBT de doble contacto es incompatible con el portaherramientas BT de doble contacto (para WBT-AHO). Por favor consultar pág. 50
- Cuando el modelo "AHO" es utilizado con alimentación de refrigerante que pasa a través del centro del portaherramienta, debe utilizarse un tornillo de retención diseñado para AHO (con pipa de refrigerante).
- Our two-face contact NBT spindle is incompatible with BT two-face contact spindle (for WBT-AHO). Please refer to p.50
- When AHO is used with center through coolant feeding, a designated retention stud (with coolant pipe) for AHO must be used.

Medidas Métricas - Metric Sizes

Unidad : Métrico
Unit : Metric

Código Code	Modelo Model	Medida MT Size MT	L1	D1	C1
3770 ※ 0010000	NBT-AHO30 or WBT-AHO30 -MTA1 -105	1	105	12.065	25
3770 ※ 0020000	NBT-AHO30 or WBT-AHO30 -MTA2 -120	2	120	17.780	32
3770 ※ 0030000	NBT-AHO30 or WBT-AHO30 -MTA3 -135	3	135	23.825	40
3770 ※ 0040000	NBT-AHO40 or WBT-AHO40 -MTA1 -120	1	120	12.065	25
3770 ※ 0050000	NBT-AHO40 or WBT-AHO40 -MTA2 -120	2	120	17.780	32
3770 ※ 0060000	NBT-AHO40 or WBT-AHO40 -MTA3 -135	3	135	23.825	40
3770 ※ 0070000	NBT-AHO40 or WBT-AHO40 -MTA4 -165	4	165	31.267	50
3770 ※ 0080000	NBT-AHO50 or WBT-AHO50 -MTA1 -120	1	120	12.065	25
3770 ※ 0090000	-180	1	180	12.065	25
3770 ※ 0100000	NBT-AHO50 or WBT-AHO50 -MTA2 -135	2	135	17.780	32
3770 ※ 0110000	-180	2	180	17.780	32
3770 ※ 0120000	NBT-AHO50 or WBT-AHO50 -MTA3 -150	3	150	23.825	40
3770 ※ 0130000	-180	3	180	23.825	40
3770 ※ 0140000	NBT-AHO50 or WBT-AHO50 -MTA4 -180	4	180	31.267	50
3770 ※ 0150000	NBT-AHO50 or WBT-AHO50 -MTA5 -210	5	210	44.399	65

Favor de reemplazar ※ en el código con Ø para el NBT-AHO y con 6 para el WBT-AHO.
Please replace ※ in the code with Ø for NBT-AHO and 6 for WBT-AHO.

Ejemplo para Ordenar - Ordering Example

Correspondiente a nuestro zanco con contacto de doble cara BT
Corresponding to our two-face contact BT spindle

NBT-AHO40 - MTA1 - 120
 Interfaz y diámetro de husillo / Shank size: NBT-AHO40
 Medida MT1 / Size MT1: MTA1
 Longitud de proyección / Projection length (L): 120

Ejemplo para Ordenar - Ordering Example

Correspondiente al zanco con contacto de doble cara BT
Corresponding to BT two-face contact spindle

WBT-AHO40 - MTA1 - 120
 Interfaz y diámetro de husillo / Shank size: WBT-AHO40
 Medida MT1 / Size MT1: MTA1
 Longitud de proyección / Projection length (L): 120

SL2

※ Se necesita un tornillo de retención AHO

※ AHO Retention Stud is required.

Side Lock Holder

- Para acabado en fresa JIS con zanco recto y llave.
- For JIS straight shank endmill with flat.

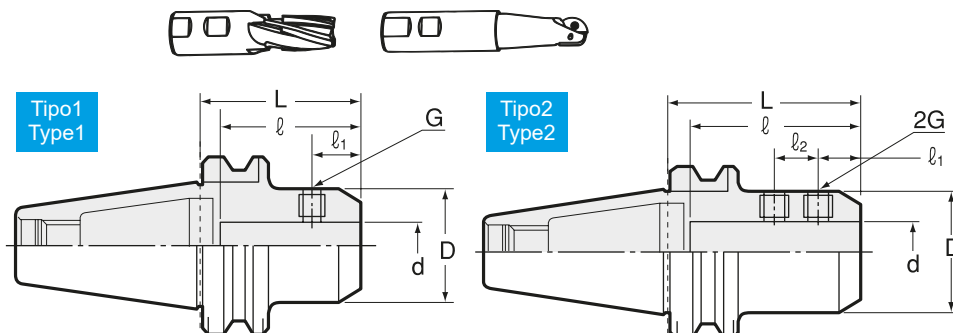
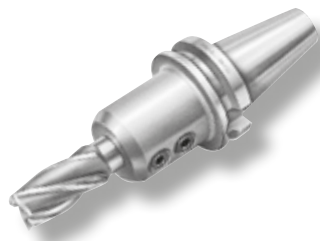

- Nuestro portaherramientas NBT de doble contacto es incompatible con el portaherramientas BT de doble contacto (para WBT-AHO). Por favor consultar pág. 50
- Cuando el modelo "AHO" es utilizado con alimentación de refrigerante que pasa a través del centro del portaherramienta, debe utilizarse un tornillo de retención diseñado para AHO (con pipa de refrigerante).
- Our two-face contact NBT spindle is incompatible with BT two-face contact spindle (for WBT-AHO). Please refer to p.50
- When AHO is used with center through coolant feeding, a designated retention stud (with coolant pipe) for AHO must be used.

Medidas Métricas - Metric Sizes

Unidad : Métrico
Unit : Metric

Código Code	Modelo Model	Tipo Type	d (H6)	D	L	ℓ	ℓ ₁	ℓ ₂	G	
3760 ※ 0010000	NBT-AHO30 or WBT-AHO30	-SL2 -6 -60	1	6	25	60	18	—	36	M6
3760 ※ 0020000		-8 -60	1	8	28	60	18	—	36	M8
3760 ※ 0030000		-10 -60	1	10	35	60	20	—	40	M10
3760 ※ 0040000		-12 -75	1	12	42	75	22.5	—	45	M12
3760 ※ 0050000		-16 -90	1	16	48	90	24	—	48	M14
3760 ※ 0060000		-20 -90	1	20	52	90	25	—	50	M16
3760 ※ 0070000	NBT-AHO40 or WBT-AHO40	-SL2 -6 -75	1	6	25	75	18	—	36	M6
3760 ※ 0080000		-8 -75	1	8	28	75	18	—	36	M8
3760 ※ 0090000		-10 -75	1	10	35	75	20	—	40	M10
3760 ※ 0100000		-12 -75	1	12	42	75	22.5	—	45	M12
3760 ※ 0110000		-16 -75	1	16	48	75	24	—	48	M14
3760 ※ 0120000		-20 -75	1	20	52	75	25	—	50	M16
3760 ※ 0130000		-25 -90	2	25	65	90	24	25	56	M18
3760 ※ 0140000		-32 -120	2	32	72	120	24	28	60	M20
3760 ※ 0150000	NBT-AHO50 or WBT-AHO50	-SL2 -6 -90	1	6	25	90	18	—	36	M6
3760 ※ 0160000		-8 -90	1	8	28	90	18	—	36	M8
3760 ※ 0170000		-10 -90	1	10	35	90	20	—	40	M10
3760 ※ 0180000		-12 -90	1	12	42	90	22.5	—	45	M12
3760 ※ 0190000		-16 -90	1	16	48	90	24	—	48	M14
3760 ※ 0200000		-20 -90	1	20	52	90	25	—	50	M16
3760 ※ 0210000		-25 -105	2	25	65	105	24	25	56	M18
3760 ※ 0220000		-32 -120	2	32	72	120	24	28	60	M20
3760 ※ 0230000		-40 -120	2	40	80	120	30	32	70	M20
3760 ※ 0240000		-42 -120	2	42	82	120	30	32	70	M20

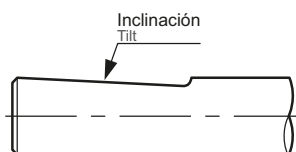

Favor de reemplazar ※ en el código con Ø para el NBT-AHO y con 6 para el WBT-AHO.
Favor de contactar a NT si la herramienta de corte se ha inclinado hasta quedar plana sobre el zanco.
El portaherramienta de la herramienta especial que va con esa inclinación puede fabricarse.
Please replace ※ in the code with Ø for NBT-AHO and 6 for WBT-AHO.
Please contact NT if the cutting tool has tilted flat on the shank.
Special tool holder that matches to the tilted flat can be manufactured.

Ejemplo para Ordenar - Ordering Example

Correspondiente a nuestro zanco con contacto de doble cara BT
Corresponding to our two-face contact BT spindle

NBT-AHO40 - SL2 - 6 - 75
Interfaz y diámetro de husillo / Shank size: 6
Diámetro Interno / I.D. (d): 40
Longitud de proyección / Projection length (L): 75

Ejemplo para Ordenar - Ordering Example

Correspondiente al zanco con contacto de doble cara BT
Corresponding to BT two-face contact spindle

WBT-AHO40 - SL2 - 6 - 75
Interfaz y diámetro de husillo / Shank size: 6
Diámetro Interno / I.D. (d): 40
Longitud de proyección / Projection length (L): 75

Face Mill Arbor (For Cutters With Oil Hole)

- El refrigerante fluye del refrentado de la locación central al cortador con el orificio para aceite.
- Coolant flows from the end face of centering location to cutter with oil hole.

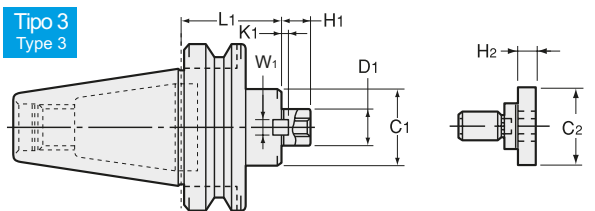
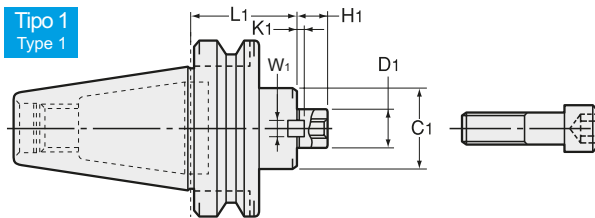
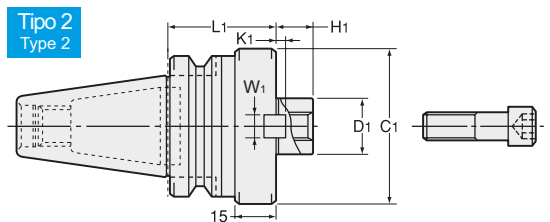
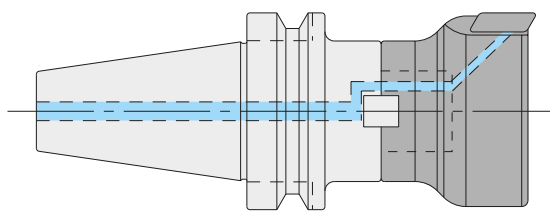

• Nuestro portaherramientas NBT de doble contacto es incompatible con el portaherramientas BT de doble contacto (para WBT-AHO). Por favor consultar pág. 50

• Cuando el modelo "AHO" es utilizado con alimentación de refrigerante que pasa a través del centro del portaherramienta, debe utilizarse un tornillo de retención diseñado para AHO (con pipa de refrigerante).

• Our two-face contact NBT spindle is incompatible with BT two-face contact spindle (for WBT-AHO). Please refer to p.50

• When AHO is used with center through coolant feeding, a designated retention stud (with coolant pipe) for AHO must be used.

Medidas Métricas - Metric Sizes

Unidad : Métrico
Unit : Metric

Código Code	Modelo Model	Tipo Type	D1 (h6)	L1	C1	H1	W1	K1	C2	H2	—	Perno de Sujeción Clamp Bolt
3810 ※3001110	NBT-AHO30 or WBT-AHO30 -FMH16A -34 -45	1	16	45	34	17	8	5	—	—	23,000	M8
3810 ※3002110	-60	1	16	60	34	17	8	5	—	—	23,000	
3810 ※3003110	-FMH22A -47 -45	3	22	45	47	18	10	5	—	—	23,500	M10
3810 ※3004110	-60	3	22	60	47	18	10	5	—	—	23,500	
3810 ※3005110	-FMH22.225A -47 -45	3	22.225	45	47	17	8	3.5	—	—	23,500	M12
3810 ※3006110	-60	3	22.225	60	47	17	8	3.5	—	—	23,500	
3810 ※3007110	-FMH25.4A -60 -60	3	25.4	60	60	22	9.5	5	—	—	23,500	M10
3810 ※3008110	-FMH27A -60 -60	3	27	60	60	20	12	6	—	—	23,500	
3810 ※3009110	NBT-AHO40 or WBT-AHO40 -FMH16A -34 -45	1	16	45	34	17	8	5	—	—	23,500	M8
3810 ※3010110	-60	1	16	60	34	17	8	5	—	—	23,500	
3810 ※3011110	-75	1	16	75	34	17	8	5	—	—	24,000	M10
3810 ※3012110	-90	1	16	90	34	17	8	5	—	—	24,000	
3810 ※3013110	-FMH22A -47 -45	1	22	45	47	18	10	5	—	—	27,400	M10
3810 ※3014110	-60	1	22	60	47	18	10	5	—	—	27,900	
3810 ※3015110	-75	1	22	75	47	18	10	5	—	—	28,200	M10
3810 ※3016110	-90	1	22	90	47	18	10	5	—	—	28,700	
3810 ※3017110	-60 -45	1	22	45	60	18	10	5	—	—	27,400	M10
3810 ※3018110	-60	1	22	60	60	18	10	5	—	—	27,900	
3810 ※3019110	-75	1	22	75	60	18	10	5	—	—	28,200	M10
3810 ※3020110	-90	1	22	90	60	18	10	5	—	—	28,700	
3810 ※3021110	-FMH22.225A -47 -45	1	22.225	45	47	17	8	3.5	—	—	27,400	M10
3810 ※3022110	-60	1	22.225	60	47	17	8	3.5	—	—	27,900	
3810 ※3023110	-75	1	22.225	75	47	17	8	3.5	—	—	28,200	M10
3810 ※3024110	-90	1	22.225	90	47	17	8	3.5	—	—	28,700	
3810 ※3025110	-60 -45	1	22.225	45	60	17	8	3.5	—	—	27,400	M10
3810 ※3026110	-60	1	22.225	60	60	17	8	3.5	—	—	27,900	
3810 ※3027110	-75	1	22.225	75	60	17	8	3.5	—	—	28,200	M10
3810 ※3028110	-90	1	22.225	90	60	17	8	3.5	—	—	28,700	
3810 ※3029110	NBT-AHO40 or WBT-AHO40 -FMH25.4A -60 -60	1	25.4	60	60	22	9.5	5	—	—	27,900	M12
3810 ※3030110	-75	1	25.4	75	60	22	9.5	5	—	—	28,200	
3810 ※3031110	-90	1	25.4	90	60	22	9.5	5	—	—	28,700	M12
3810 ※3032110	-FMH27A -60 -60	1	27	60	60	20	12	6	—	—	28,000	
3810 ※3033110	-75	1	27	75	60	20	12	6	—	—	28,400	M12
3810 ※3034110	-90	1	27	90	60	20	12	6	—	—	28,900	
3810 ※3035110	-76 -60	2	27	60	76	20	12	6	—	—	28,000	M12
3810 ※3036110	-75	2	27	75	76	20	12	6	—	—	28,400	
3810 ※3037110	-90	2	27	90	76	20	12	6	—	—	28,900	M12
3810 ※3038110	-FMH31.75A -76 -60	2	31.75	60	76	30	12.7	7	—	—	28,200	
3810 ※3039110	-75	2	31.75	75	76	30	12.7	7	—	—	28,700	M12
3810 ※3040110	-90	2	31.75	90	76	30	12.7	7	—	—	29,100	
3810 ※3041110	-96 -60	2	31.75	60	96	30	12.7	7	—	—	28,200	M16
3810 ※3042110	-75	2	31.75	75	96	30	12.7	7	—	—	28,700	
3810 ※3043110	-90	2	31.75	90	96	30	12.7	7	—	—	29,100	M16
3810 ※3044110	-FMH32A -96 -60	2	32	60	96	22	14	7	—	—	28,200	
3810 ※3045110	-75	2	32	75	96	22	14	7	—	—	28,700	M16
3810 ※3046110	-90	2	32	90	96	22	14	7	—	—	29,100	

Medidas Métricas - Metric Sizes

Unidad : Métrico
Unit : Metric

Código Code	Modelo Model	Tipo Type	D1 (h6)	L1	C1	H1	W1	K1	C2	H2	—	Perno de Sujeción Clamp Bolt		
3810 ※3047110	NBT-AHO50 or WBT-AHO50 -FMH16A	-34 -45	1	16	45	34	17	8	5	—	—	37,800	M8	
3810 ※3048110		-90	1	16	90	34	17	8	5	—	—	38,200		
3810 ※3049110		-150	1	16	150	34	17	8	5	—	—	38,700		
3810 ※3050110		-200	1	16	200	34	17	8	5	—	—	40,300		
3810 ※3051110		-250	1	16	250	34	17	8	5	—	—	68,510		
3810 ※3052110		-300	1	16	300	34	17	8	5	—	—	81,560		
3810 ※3053110	-FMH22A	-47 -45	1	22	45	47	18	10	5	—	—	37,800	M10	
3810 ※3054110		-90	1	22	90	47	18	10	5	—	—	40,900		
3810 ※3055110		-150	1	22	150	47	18	10	5	—	—	43,800		
3810 ※3056110		-200	1	22	200	47	18	10	5	—	—	44,200		
3810 ※3057110		-250	1	22	250	47	18	10	5	—	—	68,510		
3810 ※3058110		-300	1	22	300	47	18	10	5	—	—	81,560		
3810 ※3059110		-60 -45	1	22	45	60	18	10	5	—	—	37,800		
3810 ※3060110		-90	1	22	90	60	18	10	5	—	—	40,900		
3810 ※3061110		-150	1	22	150	60	18	10	5	—	—	43,800		
3810 ※3062110		-200	1	22	200	60	18	10	5	—	—	44,200		
3810 ※3063110		-250	1	22	250	60	18	10	5	—	—	68,510		
3810 ※3064110		-300	1	22	300	60	18	10	5	—	—	81,560		
3810 ※3065110	-FMH22.225A	-47 -45	1	22.225	45	47	17	8	3.5	—	—	37,800		
3810 ※3066110		-90	1	22.225	90	47	17	8	3.5	—	—	40,900		
3810 ※3067110		-150	1	22.225	150	47	17	8	3.5	—	—	43,800		
3810 ※3068110		-200	1	22.225	200	47	17	8	3.5	—	—	44,200		
3810 ※3069110		-250	1	22.225	250	47	17	8	3.5	—	—	68,510		
3810 ※3070110		-300	1	22.225	300	47	17	8	3.5	—	—	81,560		
3810 ※3071110		-60 -45	1	22.225	45	60	17	8	3.5	—	—	37,800		
3810 ※3072110		-90	1	22.225	90	60	17	8	3.5	—	—	40,900		
3810 ※3073110		-150	1	22.225	150	60	17	8	3.5	—	—	43,800		
3810 ※3074110		-200	1	22.225	200	60	17	8	3.5	—	—	44,200		
3810 ※3075110		-250	1	22.225	250	60	17	8	3.5	—	—	68,510		
3810 ※3076110		-300	1	22.225	300	60	17	8	3.5	—	—	81,560		
3810 ※3077110	-FMH25.4A	-60 -45	1	25.4	45	60	22	9.5	5	—	—	37,800	M12	
3810 ※3078110		-90	1	25.4	90	60	22	9.5	5	—	—	40,900		
3810 ※3079110		-150	1	25.4	150	60	22	9.5	5	—	—	43,800		
3810 ※3080110		-200	1	25.4	200	60	22	9.5	5	—	—	44,300		
3810 ※3081110		-250	1	25.4	250	60	22	9.5	5	—	—	68,510		
3810 ※3082110		-300	1	25.4	300	60	22	9.5	5	—	—	81,560		
3810 ※3083110	-FMH27A	-60 -45	1	27	45	60	20	12	6	—	—	37,800	M12	
3810 ※3084110		-90	1	27	90	60	20	12	6	—	—	40,900		
3810 ※3085110		-150	1	27	150	60	20	12	6	—	—	43,800		
3810 ※3086110		-200	1	27	200	60	20	12	6	—	—	44,300		
3810 ※3087110		-250	1	27	250	60	20	12	6	—	—	69,520		
3810 ※3088110		-300	1	27	300	60	20	12	6	—	—	83,120		
3810 ※3089110		-76 -45	1	27	45	76	20	12	6	—	—	37,800		
3810 ※3090110		-90	1	27	90	76	20	12	6	—	—	40,900		
3810 ※3091110		-150	1	27	150	76	20	12	6	—	—	43,800		
3810 ※3092110		-200	1	27	200	76	20	12	6	—	—	44,300		
3810 ※3093110		-250	1	27	250	76	20	12	6	—	—	69,520		
3810 ※3094110		-300	1	27	300	76	20	12	6	—	—	83,120		
3810 ※3095110	NBT-AHO50 or WBT-AHO50 -FMH31.75A	-76 -45	1	31.75	45	76	30	12.7	7	—	—	37,800		M16
3810 ※3096110		-105	1	31.75	105	76	30	12.7	7	—	—	42,900		
3810 ※3097110		-150	1	31.75	150	76	30	12.7	7	—	—	43,800		
3810 ※3098110		-200	1	31.75	200	76	30	12.7	7	—	—	44,300		
3810 ※3099110		-96 -45	1	31.75	45	96	30	12.7	7	—	—	37,800		
3810 ※3100110		-105	1	31.75	105	96	30	12.7	7	—	—	42,900		
3810 ※3101110		-150	1	31.75	150	96	30	12.7	7	—	—	43,800		
3810 ※3102110		-200	1	31.75	200	96	30	12.7	7	—	—	44,300		
3810 ※3103110	-FMH32A	-96 -45	1	32	45	96	22	14	7	—	—	37,800	MBAH-M20	
3810 ※3104110		-105	1	32	105	96	22	14	7	—	—	42,900		
3810 ※3105110		-150	1	32	150	96	22	14	7	—	—	43,800		
3810 ※3106110		-200	1	32	200	96	22	14	7	—	—	52,300		
3810 ※3107110	-FMH38.1A	-80 -45	3	38.1	45	80	34	15.9	9	50	14	37,800		
3810 ※3108110		-75	3	38.1	75	80	34	15.9	9	50	14	40,900		
3810 ※3109110		-105	3	38.1	105	80	34	15.9	9	50	14	42,900		
3810 ※3110110		-150	3	38.1	150	80	34	15.9	9	50	14	43,800		
3810 ※3111110		-100 -45	3	38.1	45	100	34	15.9	9	50	14	37,800		
3810 ※3112110		-75	3	38.1	75	100	34	15.9	9	50	14	40,900		
3810 ※3113110		-105	3	38.1	105	100	34	15.9	9	50	14	42,900		
3810 ※3114110		-150	3	38.1	150	100	34	15.9	9	50	14	43,800		
3810 ※3115110	-FMH40A	-100 -45	3	40	45	100	26	16	8.5	50	14	37,800	MBAH-M24	
3810 ※3116110		-75	3	40	75	100	26	16	8.5	50	14	40,900		
3810 ※3117110		-105	3	40	105	100	26	16	8.5	50	14	42,900		
3810 ※3118110		-150	3	40	150	100	26	16	8.5	50	14	43,800		
3810 ※3119110	-FMH50.8A	-100 -45	3	50.8	45	100	36	19.05	10	65	14	37,800		
3810 ※3120110		-75	3	50.8	75	100	36	19.05	10	65	14	40,900		
3810 ※3121110		-105	3	50.8	105	100	36	19.05	10	65	14	42,900		
3810 ※3122110		-150	3	50.8	150	100	36	19.05	10	65	14	43,800		

- BT
- CAT
- AHO**
- HSK-A/E/F/C
- HSK-T
- C
- UTS
- Máquinas Especializadas Specialized Machine
- Equipo Relacionado Related Equipment
- Taladro de Biselado & de Casquillo Bush & Chamfering Drill
- Milling Chuck
- Collet Holder
- "R" Zero Holder
- Hydraulic Chuck
- Shrink Fit
- Tapping Chuck
- Anchors
- Function Holder
- Retention Stud

Favor de reemplazar ※ en el código con Ø para el NBT-AHO y con 6 para el WBT-AHO.
Please replace ※ in the code with Ø for NBT-AHO and 6 for WBT-AHO.

Incluye el perno de sujeción.
Clamp bolt is Included.

Ejemplo para Ordenar - Ordering Example

Correspondiente a nuestro zanco con contacto de doble cara BT
Corresponding to our two-face contact BT spindle

NBT-AHO50 - FMH31.75 A - 76 - 45			
Interfaz y diámetro de husillo	D1	C1	Longitud de proyección
AHO Shank size	D1	C1	Projection length

Ejemplo para Ordenar - Ordering Example

Correspondiente al zanco con contacto de doble cara BT
Corresponding to BT two-face contact spindle

WBT-AHO50 - FMH 31.75 A - 76 - 45			
Interfaz y diámetro de husillo	D1	C1	Longitud de proyección
AHO Shank size	D1	C1	Projection length



Face Mill Arbor

● Para fresa JIS B4113

● For JIS B4113 face mill.

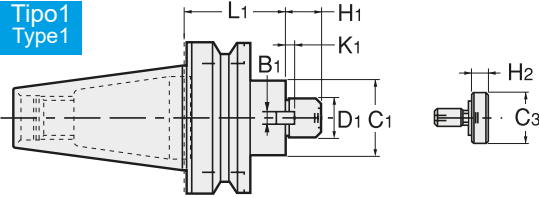
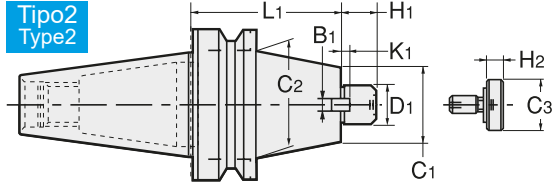
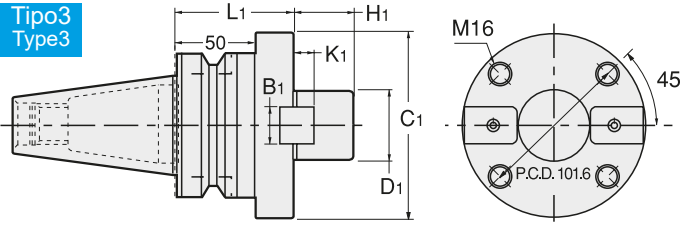
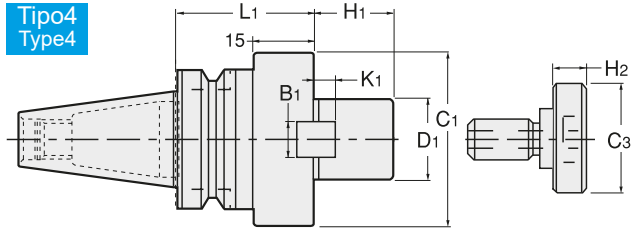
Tipo1
Type1Tipo2
Type2Tipo3
Type3Tipo4
Type4

- Nuestro portaherramientas NBT de doble contacto es incompatible con el portaherramientas BT de doble contacto (para WBT-AHO). Por favor consultar pág. 50
- Cuando el modelo "AHO" es utilizado con alimentación de refrigerante que pasa a través del centro del portaherramienta, debe utilizarse un tornillo de retención diseñado para AHO (con pipa de refrigerante).
- Our two-face contact NBT spindle is incompatible with BT two-face contact spindle (for WBT-AHO). Please refer to p.50
- When AHO is used with center through coolant feeding, a designated retention stud (with coolant pipe) for AHO must be used.

Medidas Métricas - Metric Sizes

Unidad : Métrico
Unit : Metric

Código Code	Modelo Model	Tipo Type	D1	L1	C1	C2	H1	W1	K1	C3	H2	kg	—	Perno de Sujeción Clamp Bolt	Ejemplo del diá. de cortador Cutter dia. Example
3810 ※ 0350010	NBT-AHO30 or WBT-AHO30 -FMA22.225A -45	1	22.225	45	42	—	18	8	4	—	—	14,400		M10	50
3810 ※ 0360010	-60	1	22.225	60	42	—	18	8	4	—	—	0.8	14,400		
3810 ※ 0260010	-FMA25.4A -45	4	25.4	45	50	—	22	9.5	5	33	10	0.8	14,400	MBA-M12	76
3810 ※ 0250010	-60	4	25.4	60	50	—	22	9.5	5	33	10	1.0	14,400		
3810 ※ 0010010	NBT-AHO40 or WBT-AHO40 -FMA25.4A -45	1	25.4	45	50	—	22	9.5	5	33	10		18,000		
3810 ※ 0370010	-60	1	25.4	60	50	—	22	9.5	5	33	10		18,000	MBA-M12	76
3810 ※ 0380010	-75	1	25.4	75	50	—	22	9.5	5	33	10		19,200		
3810 ※ 0020010	-90	1	25.4	90	50	—	22	9.5	5	33	10		19,200		
3810 ※ 0030010	-FMA31.75A -45	1	31.75	45	60	—	30	12.7	7	40	10		18,000		
3810 ※ 0390010	-60	1	31.75	60	60	—	30	12.7	7	40	10		18,000	MBA-M16	102
3810 ※ 0040010	-75	1	31.75	75	60	—	30	12.7	7	40	10	2.1	19,200		
3810 ※ 0400010	-90	1	31.75	90	60	—	30	12.7	7	40	10		19,200		
3810 ※ 0050010	-FMA38.1A -60	4	38.1	60	80	—	34	15.9	9	50	14		21,600		
3810 ※ 0410010	-75	4	38.1	75	80	—	34	15.9	9	50	14		22,800	MBA-M20	127
3810 ※ 0420010	-90	4	38.1	90	80	—	34	15.9	9	50	14		22,800		
3810 ※ 0060010	NBT-AHO50 or WBT-AHO50 -FMA25.4A -45	1	25.4	45	50	—	22	9.5	5	33	10		26,400		
3810 ※ 0070010	-90	2	25.4	90	50	70	22	9.5	5	33	10		28,800		
3810 ※ 0080010	-150	2	25.4	150	50	70	22	9.5	5	33	10		31,200	MBA-M12	76
3810 ※ 0090010	-200	2	25.4	200	50	70	22	9.5	5	33	10	6.5	33,600		
3810 ※ 0430010	-250 *	2	25.4	250	50	70	22	9.5	5	33	10		38,400		
3810 ※ 0440010	-300 *	2	25.4	300	50	70	22	9.5	5	33	10		45,600		
3810 ※ 0100010	-FMA31.75A -45	1	31.75	45	60	—	30	12.7	7	40	10		26,400		
3810 ※ 0110010	-75	2	31.75	75	60	70	30	12.7	7	40	10		28,800		
3810 ※ 0120010	-105	2	31.75	105	60	70	30	12.7	7	40	10	4.8	31,200		
3810 ※ 0130010	-150	2	31.75	150	60	70	30	12.7	7	40	10		33,600	MBA-M16	102
3810 ※ 0140010	-200	2	31.75	200	60	90	30	12.7	7	40	10	7.8	36,000		
3810 ※ 0150010	-250 *	2	31.75	250	60	90	30	12.7	7	40	10		38,400		
3810 ※ 0450010	-300 *	2	31.75	300	60	90	30	12.7	7	40	10	10.8	45,600		

Medidas Métricas – Metric Sizes

Unidad : Métrico
Unit : Metric

Código Code	Modelo Model	Tipo Type	D1	L1	C1	C2	H1	W1	K1	C3	H2	kg	—	Perno de Sujeción Clamp Bolt	Ejemplo del diá. de cortador Cutter dia.
3810 ※ 0160010	NBT-AHO50 or WBT-AHO50 -FMA38.1A -45	1	38.1	45	80	—	34	15.9	9	50	14		26,400	MBA-M20	127
3810 ※ 0170010	-75	1	38.1	75	80	—	34	15.9	9	50	14		28,800		
3810 ※ 0180010	-105	1	38.1	105	80	—	34	15.9	9	50	14		31,200		
3810 ※ 0190010	-150	1	38.1	150	80	—	34	15.9	9	50	14		33,600		
3810 ※ 0240010	-FMA47.625A -75 *	3	47.625	75	128.57	—	38	25.4	12.5	—	—	6.9	37,200	M16	203
3810 ※ 0200010	-FMA50.8A -45	1	50.8	45	100	—	36	19.05	10	65	14		26,400	MBA-M24	152 178
3810 ※ 0210010	-75	1	50.8	75	100	—	36	19.05	10	65	14	5.8	28,800		
3810 ※ 0220010	-105	1	50.8	105	100	—	36	19.05	10	65	14		31,200		
3810 ※ 0230010	-150	1	50.8	150	100	—	36	19.05	10	65	14		33,600		

Favor de reemplazar ※ en el código con Ø para el NBT-AHO y con 6 para el WBT-AHO.
Los modelos con * no son compatibles con el suministro de refrigerante a través del centro.
Incluye el perno de sujeción.
Please replace ※ in the code with Ø for NBT-AHO and 6 for WBT-AHO.
Models with * are not center through coolant feed compliant.
Clamp bolt is Included.

Ejemplo para Ordenar - Ordering Example

Correspondiente a nuestro zanco con contacto de doble cara BT
Corresponding to our two-face contact BT spindle

NBT-AHO40 - FMA 25.4 A - 60
Interfaz y diámetro de husillo D1 Longitud de proyección
Shank size D1 Projection length (L)

Ejemplo para Ordenar - Ordering Example

Correspondiente al zanco con contacto de doble cara BT
Corresponding to BT two-face contact spindle

WBT-AHO40 - FMA 25.4 A - 60
Interfaz y diámetro de husillo D1 Longitud de proyección
Shank size D1 Projection length (L)

AHO

BT

CAT

AHO

HSK-A/E/F/C

HSK-T

C

UTS

Máquinas Especializadas

Specialized Machine

Equipo Relacionado

Related Equipment

Taladro de Biselado & de Casquillo

Bush & Chamfering Drill

Drill

Milling Chuck

Collet Holder

"R" Zero Holder

Hydraulic Chuck

Shrink Fit

Tapping Chuck

Ahors

Function Holder

Retention Stud

Face Mill Arbor

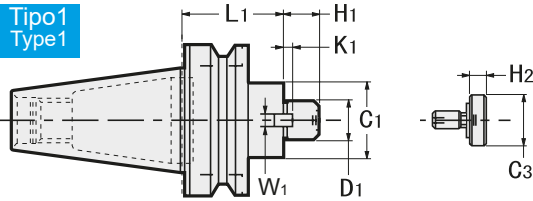
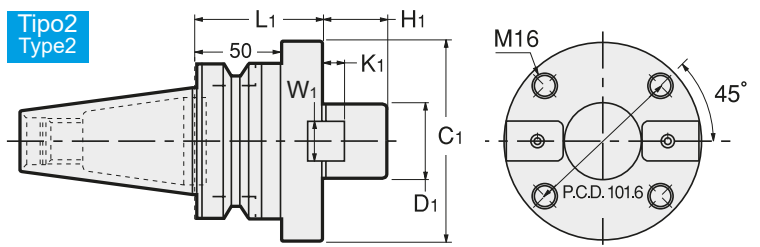
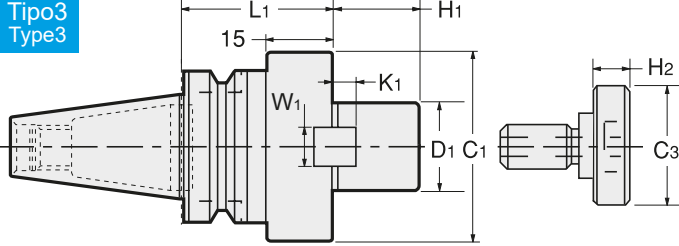
Tipo1
Type1Tipo2
Type2Tipo3
Type3

- Nuestro portaherramientas NBT de doble contacto es incompatible con el portaherramientas BT de doble contacto (para WBT-AHO). Por favor consultar pág. 50
- Cuando el modelo "AHO" es utilizado con alimentación de refrigerante que pasa a través del centro del portaherramienta, debe utilizarse un tornillo de retención diseñado para AHO (con pipa de refrigerante).
- Our two-face contact NBT spindle is incompatible with BT two-face contact spindle (for WBT-AHO). Please refer to p.50
- When AHO is used with center through coolant feeding, a designated retention stud (with coolant pipe) for AHO must be used.



Medidas Métricas - Metric Sizes

Unidad : Métrico
Unit : Metric

Código Code	Modelo Model	Tipo Type	D1	L1	C1	H1	W1	K1	C3	H2	kg	—	Perno de Sujeción Clamp Bolt	Ejemplo del diá. de cortador Cutter dia. Example
3810 ※ 1010010	NBT-AHO30 or WBT-AHO30 -FMB27A -45	3	27	45	80	26	12	6	33	10	14,400		MBA-M12	80
3810 ※ 1020010	-60	3	27	60	80	26	12	6	33	10	14,400			
3810 ※ 1030010	NBT-AHO40 or WBT-AHO40 -FMB27A -60	3	27	60	80	26	12	6	33	10	18,000		MBA-M12	80
3810 ※ 1040010	-90	3	27	90	80	26	12	6	33	10	19,200	2.7		
3810 ※ 1050010	-FMB40A -60	3	40	60	85	26	16	8.5	50	14	21,600		MBA-M20	100 125
3810 ※ 1060010	NBT-AHO50 or WBT-AHO50 -FMB27A -45	1	27	45	80	26	12	6	33	10	26,400		MBA-M12	80
3810 ※ 1070010	-90	1	27	90	80	26	12	6	33	10	28,800			
3810 ※ 1080010	-150	1	27	150	80	26	12	6	33	10	31,200			
3810 ※ 1090010	-FMB40A -45	1	40	45	85	26	16	8.5	50	14	26,400			
3810 ※ 1100010	-75	1	40	75	85	26	16	8.5	50	14	28,800		MBA-M20	100 125
3810 ※ 1110010	-105	1	40	105	85	26	16	8.5	50	14	31,200			
3810 ※ 1120010	-FMB60A -75 *	2	60	75	140	25	25.4	12.5	—	—	7.2	42,000	M16	200

Los modelos con * no son compatibles con el suministro de refrigerante a través del centro.

Incluye el perno de sujeción.

Models with * are not center through coolant feed compliant.

Clamp bolt is Included.

Medida en Pulgadas - Inch Sizes

Unidad : Métrico
Unit : Metric

Código Code	Modelo Model	Tipo Type	D1	L1	C1	H1	W1	K1	C3	H2	—	Perno de Sujeción Clamp Bolt	Ejemplo del diá. de cortador Cutter dia. Example
3810 ※ 1130010	NBT-AHO30 or WBT-AHO30 -FMB25.4A -45	3	25.4	45	80	26	9.5	5	33	10	14,400	MBA-M12	80
3810 ※ 1140010	-60	3	25.4	60	80	26	9.5	5	33	10	14,400		
3810 ※ 1150010	NBT-AHO40 or WBT-AHO40 -FMB25.4A -60	3	25.4	60	80	26	9.5	5	33	10	18,000	MBA-M12	80
3810 ※ 1160010	-90	3	25.4	90	80	26	9.5	5	33	10	19,200		
3810 ※ 1170010	-FMB38.1A -60	3	38.1	60	85	26	15.9	9	50	14	21,600	MBA-M20	100 125
3810 ※ 1180010	NBT-AHO50 or WBT-AHO50 -FMB25.4A -45	1	25.4	45	80	26	9.5	5	33	10	26,400	MBA-M12	80
3810 ※ 1190010	-90	1	25.4	90	80	26	9.5	5	33	10	28,800		
3810 ※ 1200010	-150	1	25.4	150	80	26	9.5	5	33	10	31,200		
3810 ※ 1210010	-FMB38.1A -45	1	38.1	45	85	26	15.9	9	50	14	26,400		
3810 ※ 1220010	-75	1	38.1	75	85	26	15.9	9	50	14	28,800	MBA-M20	100 125
3810 ※ 1230010	-105	1	38.1	105	85	26	15.9	9	50	14	31,200		

Favor de reemplazar ※ en el código con Ø para el NBT-AHO y con 6 para el WBT-AHO.

Incluye el perno de sujeción.

Please replace ※ in the code with Ø for NBT-AHO and 6 for WBT-AHO.

Clamp bolt is Included.

Ejemplo para Ordenar - Ordering Example

Correspondiente a nuestro zanco con contacto de doble cara BT

Corresponding to our two-face contact BT spindle

NBT-AHO40 - FMB 25.4 A - 60

Interfaz y diámetro de husillo Shank size	D1	Longitud de proyección Projection length (L)
	D1	

Ejemplo para Ordenar - Ordering Example

Correspondiente al zanco con contacto de doble cara BT

Corresponding to BT two-face contact spindle

WBT-AHO40 - FMB 25.4 A - 60

Interfaz y diámetro de husillo Shank size	D1	Longitud de proyección Projection length (L)
	D1	

AHO

BT

CAT

AHO

HSK-A/E/F/C

HSK-T

C

UTS

Máquinas Especializadas
Specialized Machine

Equipo Relacionado
Related Equipment

Taladro de Biselado & de Casquillo
Bush & Chamfering Drill

Milling Chuck

Collet Holder

"R" Zero Holder

Hydraulic Chuck

Shrink Fit

Tapping Chuck

Anchors

Function Holder

Retention Stud

Face Mill Arbor

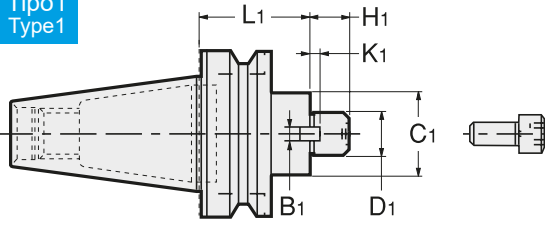
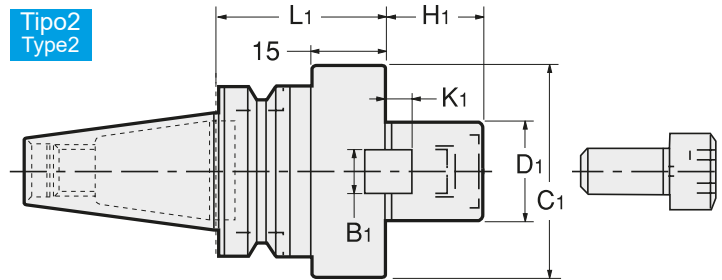
Tipo1
Type1Tipo2
Type2

- Nuestro portaherramientas NBT de doble contacto es incompatible con el portaherramientas BT de doble contacto (para WBT-AHO). Por favor consultar pág. 50
- Cuando el modelo "AHO" es utilizado con alimentación de refrigerante que pasa a través del centro del portaherramienta, debe utilizarse un tornillo de retención diseñado para AHO (con pipa de refrigerante).
- Our two-face contact NBT spindle is incompatible with BT two-face contact spindle (for WBT-AHO). Please refer to p.50
- When AHO is used with center through coolant feeding, a designated retention stud (with coolant pipe) for AHO must be used.

Medida en Pulgadas - Inch Sizes

Unidad : Métrico
Unit : Metric

Código Code	Modelo Model	Tipo Type	D1	L1	C1	H1	B1	K1	kg	—	Perno de Sujeción Clamp Bolt	Ejemplo del diá. de cortador Cutter dia. Example
3810 ※ 2300010	NBT-AHO30 or WBT-AHO30 FMC25.4A -45	2	25.4	45	70	20	9.5	5		14,400	M12	80
3810 ※ 2310010	-60	2	25.4	60	70	20	9.5	5		14,400		
3810 ※ 2320010	NBT-AHO40 or WBT-AHO40 FMC25.4A -60	2	25.4	60	70	20	9.5	5	1.8	18,000	M12	80
3810 ※ 2330010	-90	2	25.4	90	70	20	9.5	5		19,200		
3810 ※ 2340010	FMC38.1A -60	2	38.1	60	85	22	15.9	7		18,000	M16	100
3810 ※ 2350010	-75	2	38.1	75	85	22	15.9	7		19,200		
3810 ※ 2360010	NBT-AHO50 or WBT-AHO50 FMC25.4A -45	1	25.4	45	70	20	9.5	5		26,400	M12	80
3810 ※ 2370010	-90	1	25.4	90	70	20	9.5	5		28,800		
3810 ※ 2380010	-150	1	25.4	150	70	20	9.5	5		31,200		
3810 ※ 2390010	FMC38.1A -45	1	38.1	45	85	22	15.9	7		26,400	M16	100
3810 ※ 2400010	-75	1	38.1	75	85	22	15.9	7		28,800		
3810 ※ 2410010	-105	1	38.1	105	85	22	15.9	7		31,200		

Incluye el perno de sujeción.

Clamp bolt is Included.

Medidas Métricas - Metric Sizes

Unidad : Métrico
Unit : Metric

Código Code	Modelo Model	Tipo Type	D1	L1	C1	H1	W1	K1	kg	—	Perno de Sujeción Clamp Bolt	Ejemplo del diá. de cortador Cutter dia. Example	
3810 ※ 2010010	NBT-AHO30 or WBT-AHO30	-FMC22A -45	1	22	45	45	18	10	5	0.7	14,400	M10	50 63
3810 ※ 2020010		-60	1	22	60	45	18	10	5		14,400		
3810 ※ 2030010	NBT-AHO40 or WBT-AHO40	-FMC22A -45	1	22	45	45	18	10	5	1.1	18,000	M10	50 63
3810 ※ 2040010		-60	1	22	60	45	18	10	5		18,000		
3810 ※ 2050010		-75	1	22	75	45	18	10	5		19,200		
3810 ※ 2060010		-90	1	22	90	45	18	10	5	1.7	19,200		
3810 ※ 2080010		-FMC27A -60	2	27	60	70	20	12	6		18,000		
3810 ※ 2090010		-75	2	27	75	70	20	12	6		19,200	M12	80
3810 ※ 2100010		-90	2	27	90	70	20	12	6		19,200		
3810 ※ 2110010		-FMC32A -60	2	32	60	85	22	14	7		18,000		
3810 ※ 2120010		-75	2	32	75	85	22	14	7		19,200	M16	100
3810 ※ 2130010		-90	2	32	90	85	22	14	7		19,200		
3810 ※ 2140010	NBT-AHO50 or WBT-AHO50	-FMC22A -45	1	22	45	45	18	10	5		26,400	M10	50 63
3810 ※ 2150010		-90	1	22	90	45	18	10	5		28,800		
3810 ※ 2160010		-150	1	22	150	45	18	10	5		31,200		
3810 ※ 2170010		-200	1	22	200	45	18	10	5		33,600		
3810 ※ 2180010		-250 *	1	22	250	45	18	10	5		38,400		
3810 ※ 2190010		-300 *	1	22	300	45	18	10	5		45,600		
3810 ※ 2200010		-FMC27A -45	1	27	45	70	20	12	6		26,400	M12	80
3810 ※ 2210010		-105	1	27	105	70	20	12	6		31,200		
3810 ※ 2220010		-150	1	27	150	70	20	12	6		33,600		
3810 ※ 2230010		-200	1	27	200	70	20	12	6		36,000		
3810 ※ 2240010		-250 *	1	27	250	70	20	12	6		38,400		
3810 ※ 2250010		-300 *	1	27	300	70	20	12	6		45,600		
3810 ※ 2260010		-FMC32A -45	1	32	45	85	22	14	7		26,400	M16	100
3810 ※ 2270010		-75	1	32	75	85	22	14	7		28,800		
3810 ※ 2280010		-105	1	32	105	85	22	14	7		31,200		
3810 ※ 2290010		-150	1	32	150	85	22	14	7		33,600		

Favor de reemplazar ※ en el código con Ø para el NBT-AHO y con 6 para el WBT-AHO.
Los modelos con la marca * no son compatibles con el suministro de refrigerante a través del centro.
Incluye el perno de sujeción.

Please replace ※ in the code with Ø for NBT-AHO and 6 for WBT-AHO.
Models with * are not center through coolant feed compliant.
Clamp bolt is Included.

Ejemplo para Ordenar - Ordering Example

Correspondiente a nuestro zanco con contacto de doble cara BT
Corresponding to our two-face contact BT spindle

NBT-AHO40 - FMC 25.4 A - 60

Interfaz y diámetro de husillo D1 Longitud de proyección
Shank size D1 Projection length (L)

Ejemplo para Ordenar - Ordering Example

Correspondiente al zanco con contacto de doble cara BT
Corresponding to BT two-face contact spindle

WBT-AHO40 - FMC 25.4 A - 60

Interfaz y diámetro de husillo D1 Longitud de proyección
Shank size D1 Projection length (L)

Side Cutter Arbor

- Para cortador lateral JIS y sierra metálica.
- For JIS side cutter and metal saw.

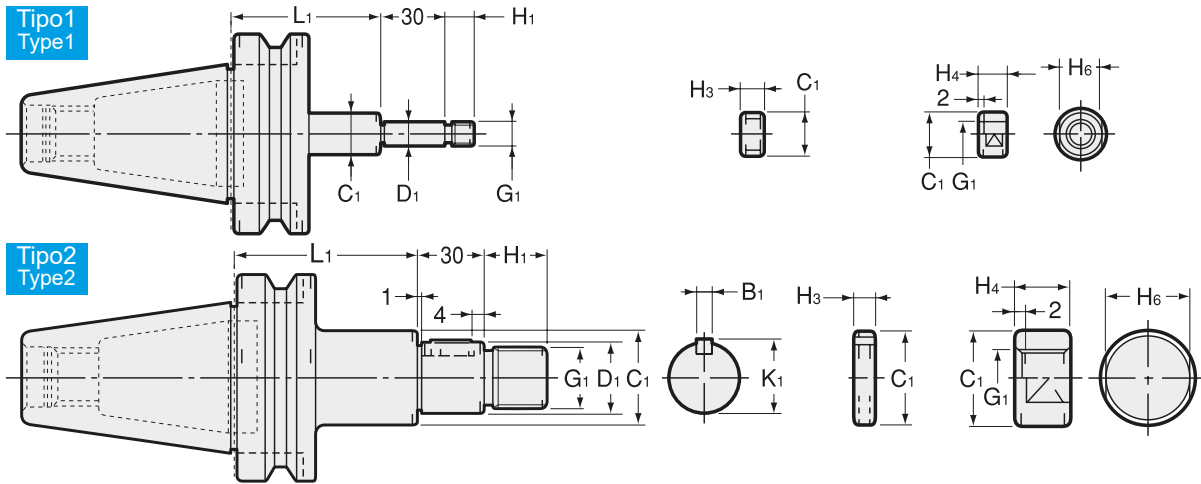

- Nuestro portaherramientas NBT de doble contacto es incompatible con el portaherramientas BT de doble contacto (para WBT-AHO). Por favor consultar pág. 50
- Cuando el modelo "AHO" es utilizado con alimentación de refrigerante que pasa a través del centro del portaherramienta, debe utilizarse un tornillo de retención diseñado para AHO (con pipa de refrigerante).
- Our two-face contact NBT spindle is incompatible with BT two-face contact spindle (for WBT-AHO). Please refer to p.50
- When AHO is used with center through coolant feeding, a designated retention stud (with coolant pipe) for AHO must be used.

Medida en Pulgadas - Inch Sizes

Unidad : Métrico
Unit : Metric

Código Code	Modelo Model	Tipo Type	D1 (h6)	L1	C1	G1	H1	B1	K1	H3	H4	H6	Ejemplo del diá. de cortador Cutter dia. Example
3780 ※ 0250000	NBT-AHO30 or WBT-AHO30 -SCA12.7 -75	1	12.7	75	20	M12 × 1.25	15	—	—	3,5,7,8,10,12	12	17	50
3780 ※ 0260000	NBT-AHO30 or WBT-AHO30 -SCA15.875-75	2	15.875	75	26	M14 × 1.5	16	3.18	17.42	3,5,7,8,10,12	13	22	50 ~ 63
3780 ※ 0270000	NBT-AHO30 or WBT-AHO30 -SCA22.225-75	2	22.225	75	34	M20 × 1.5	21	3.18	23.82	3,5,7,8,10,12	18	30	60 ~ 63
3780 ※ 0280000	NBT-AHO40 or WBT-AHO40 -SCA12.7 -60	1	12.7	60	20	M12 × 1.25	15	—	—	3,5,7,8,10,12	12	17	50
3780 ※ 0290000	NBT-AHO40 or WBT-AHO40 -90	1	12.7	90	20	M12 × 1.25	15	—	—	3,5,7,8,10,12	12	17	50
3780 ※ 0300000	NBT-AHO40 or WBT-AHO40 -SCA15.875-75	2	15.875	75	26	M14 × 1.5	16	3.18	17.42	3,5,7,8,10,12	13	22	50 ~ 63
3780 ※ 0310000	NBT-AHO40 or WBT-AHO40 -105	2	15.875	105	26	M14 × 1.5	16	3.18	17.42	3,5,7,8,10,12	13	22	50 ~ 63
3780 ※ 0320000	NBT-AHO40 or WBT-AHO40 -SCA22.225-75	2	22.225	75	34	M20 × 1.5	21	3.18	23.82	3,5,7,8,10,12	18	30	60 ~ 63
3780 ※ 0330000	NBT-AHO40 or WBT-AHO40 -120	2	22.225	120	34	M20 × 1.5	21	3.18	23.82	3,5,7,8,10,12	18	30	60 ~ 63
3780 ※ 0340000	NBT-AHO40 or WBT-AHO40 -SCA25.4 -75	2	25.4	75	40	M24 × 2	25	6.35	27.78	3,5,7,8,10,12	21	32	75 ~ 125
3780 ※ 0350000	NBT-AHO40 or WBT-AHO40 -120	2	25.4	120	40	M24 × 2	25	6.35	27.78	3,5,7,8,10,12	21	32	75 ~ 125
3780 ※ 0360000	NBT-AHO40 or WBT-AHO40 -SCA31.75 -90	2	31.75	90	46	M30 × 2	30	7.92	34.92	3,5,7,8,10,12	26	41	100 ~ 250
3780 ※ 0370000	NBT-AHO50 or WBT-AHO50 -SCA12.7 -75	1	12.7	75	20	M12 × 1.25	15	—	—	3,5,7,8,10,12	12	17	50
3780 ※ 0380000	NBT-AHO50 or WBT-AHO50 -105	1	12.7	105	20	M12 × 1.25	15	—	—	3,5,7,8,10,12	12	17	50
3780 ※ 0390000	NBT-AHO50 or WBT-AHO50 -SCA15.875-90	2	15.875	90	26	M14 × 1.5	16	3.18	17.42	3,5,7,8,10,12	13	22	50 ~ 63
3780 ※ 0400000	NBT-AHO50 or WBT-AHO50 -120	2	15.875	120	26	M14 × 1.5	16	3.18	17.42	3,5,7,8,10,12	13	22	50 ~ 63
3780 ※ 0410000	NBT-AHO50 or WBT-AHO50 -SCA22.225-90	2	22.225	90	34	M20 × 1.5	21	3.18	23.82	3,5,7,8,10,12	18	30	60 ~ 63
3780 ※ 0420000	NBT-AHO50 or WBT-AHO50 -135	2	22.225	135	34	M20 × 1.5	21	3.18	23.82	3,5,7,8,10,12	18	30	60 ~ 63
3780 ※ 0430000	NBT-AHO50 or WBT-AHO50 -SCA25.4 -90	2	25.4	90	40	M24 × 2	25	6.35	27.78	3,5,7,8,10,12	21	32	75 ~ 125
3780 ※ 0440000	NBT-AHO50 or WBT-AHO50 -135	2	25.4	135	40	M24 × 2	25	6.35	27.78	3,5,7,8,10,12	21	32	75 ~ 125

Medida en Pulgadas - Inch Sizes

Unidad : Métrico
Unit : Metric

Código Code	Modelo Model	Tipo Type	D1 (h6)	L1	C1	G1	H1	B1	K1	H3	H4	H6	Ejemplo del diá. de cortador Cutter dia. Example	
3780 ※ 0450000	NBT-AHO50 or WBT-AHO50	-SCA31.75 -90	2	31.75	90	46	M30 × 2	30	7.92	34.92	3,5,7,8,10,12	26	41	100 ~ 250
3780 ※ 0460000		-135	2	31.75	135	46	M30 × 2	30	7.92	34.92	3,5,7,8,10,12	26	41	100 ~ 250
3780 ※ 0470000	NBT-AHO50 or WBT-AHO50	-SCA38.1 -90	2	38.1	90	55	M36 × 3	36	9.52	42.06	3,5,7,8,10,12	31	46	150 ~ 315
3780 ※ 0480000		-135	2	38.1	135	55	M36 × 3	36	9.52	42.06	3,5,7,8,10,12	31	46	150 ~ 315

Medidas Métricas - Metric Sizes

Unidad : Métrico
Unit : Metric

Código Code	Modelo Model	Tipo Type	D1 (h6)	L1	C1	G1	H1	B1	K1	H3	H4	H6	Ejemplo del diá. de cortado Cutter dia. Example	
3780 ※ 0010000	NBT-AHO30 or WBT-AHO30	-SCA13 -75	1	13	75	20	M12 × 1.25	15	—	—	3,5,7,8,10,12	12	17	50
3780 ※ 0020000	NBT-AHO30 or WBT-AHO30	-SCA16 -75	2	16	75	26	M14 × 1.5	16	4	17.2	3,5,7,8,10,12	13	22	50 ~ 63
3780 ※ 0030000	NBT-AHO30 or WBT-AHO30	-SCA22 -75	2	22	75	34	M20 × 1.5	21	6	23.6	3,5,7,8,10,12	18	30	60 ~ 125
3780 ※ 0040000	NBT-AHO40 or WBT-AHO40	-SCA13 -60	1	13	60	20	M12 × 1.25	15	—	—	3,5,7,8,10,12	12	17	50
3780 ※ 0050000		-90	1	13	90	20	M12 × 1.25	15	—	—	3,5,7,8,10,12	12	17	50
3780 ※ 0060000	NBT-AHO40 or WBT-AHO40	-SCA16 -75	2	16	75	26	M14 × 1.5	16	4	17.2	3,5,7,8,10,12	13	22	50 ~ 63
3780 ※ 0070000		-105	2	16	105	26	M14 × 1.5	16	4	17.2	3,5,7,8,10,12	13	22	50 ~ 63
3780 ※ 0080000	NBT-AHO40 or WBT-AHO40	-SCA22 -75	2	22	75	34	M20 × 1.5	21	6	23.6	3,5,7,8,10,12	18	30	60 ~ 125
3780 ※ 0090000		-120	2	22	120	34	M20 × 1.5	21	6	23.6	3,5,7,8,10,12	18	30	60 ~ 125
3780 ※ 0100000	NBT-AHO40 or WBT-AHO40	-SCA27 -75	2	27	75	40	M24 × 2	25	7	29	3,5,7,8,10,12	21	32	75 ~ 100
3780 ※ 0110000		-120	2	27	120	40	M24 × 2	25	7	29	3,5,7,8,10,12	21	32	75 ~ 100
3780 ※ 0120000	NBT-AHO40 or WBT-AHO40	-SCA32 -90	2	32	90	46	M30 × 2	30	8	34	3,5,7,8,10,12	26	41	100 ~ 250
3780 ※ 0130000	NBT-AHO50 or WBT-AHO50	-SCA13 -75	1	13	75	20	M12 × 1.25	15	—	—	3,5,7,8,10,12	12	17	50
3780 ※ 0140000		-105	1	13	105	20	M12 × 1.25	15	—	—	3,5,7,8,10,12	12	17	50
3780 ※ 0150000	NBT-AHO50 or WBT-AHO50	-SCA16 -90	2	16	90	26	M14 × 1.5	16	4	17.2	3,5,7,8,10,12	13	22	50 ~ 63
3780 ※ 0160000		-120	2	16	120	26	M14 × 1.5	16	4	17.2	3,5,7,8,10,12	13	22	50 ~ 63
3780 ※ 0170000	NBT-AHO50 or WBT-AHO50	-SCA22 -90	2	22	90	34	M20 × 1.5	21	6	23.6	3,5,7,8,10,12	18	30	60 ~ 125
3780 ※ 0180000		-135	2	22	135	34	M20 × 1.5	21	6	23.6	3,5,7,8,10,12	18	30	60 ~ 125
3780 ※ 0190000	NBT-AHO50 or WBT-AHO50	-SCA27 -90	2	27	90	40	M24 × 2	25	7	29	3,5,7,8,10,12	21	32	75 ~ 100
3780 ※ 0200000		-135	2	27	135	40	M24 × 2	25	7	29	3,5,7,8,10,12	21	32	75 ~ 100
3780 ※ 0210000	NBT-AHO50 or WBT-AHO50	-SCA32 -90	2	32	90	46	M30 × 2	30	8	34	3,5,7,8,10,12	26	41	100 ~ 250
3780 ※ 0220000		-135	2	32	135	46	M30 × 2	30	8	34	3,5,7,8,10,12	26	41	100 ~ 250
3780 ※ 0230000	NBT-AHO50 or WBT-AHO50	-SCA40 -90	2	40	90	55	M36 × 3	36	10	42.5	3,5,7,8,10,12	31	46	150 ~ 315
3780 ※ 0240000		-135	2	40	135	55	M36 × 3	36	10	42.5	3,5,7,8,10,12	31	46	150 ~ 315

Favor de reemplazar ※ en el código con Ø para el NBT-AHO y con 6 para el WBT-AHO.
 Incluye una tuerca de sujeción y espaciadores (en medidas 3, 5, 7, 8, 10 y 12/ uno de cada uno).
 Please replace ※ in the code with Ø for NBT-AHO and 6 for WBT-AHO.
 One clamp nut and spacers (size 3, 5, 7, 8, 10, and 12 / one each) are included.

Ejemplo para Ordenar - Ordering Example

Correspondiente a nuestro zanco con contacto de doble cara BT
 Corresponding to our two-face contact BT spindle

NBT-AHO40 - SCA 12.7 - 75

Interfaz y diámetro de husillo Shank size Diámetro D1 D1 Longitud de proyección Projection length (L)

Ejemplo para Ordenar - Ordering Example

Correspondiente al zanco con contacto de doble cara BT
 Corresponding to BT two-face contact spindle

WBT-AHO40 - SCA 12.7 - 75

Interfaz y diámetro de husillo Shank size Diámetro D1 D1 Longitud de proyección Projection length (L)



- BT
- CAT
- AHO
- HSK-A/E/F/C
- HSK-T
- C
- UTS
- Máquinas Especializadas Specialized Machine
- Equipo Relacionado Related Equipment
- Taladro de Biselado y de Casquillo Bush & Chamfering Drill
- Milling Chuck
- Collet Holder
- "R" Zero Holder
- Hydraulic Chuck
- Shrink Fit
- Tapping Chuck
- Anchors
- Function Holder
- Retention Stud

AH, AH-OH

90°

Angle Heads (Fixed Type)

※ Se necesita un tornillo de retención AHO

※ AHO Retention Stud is required.

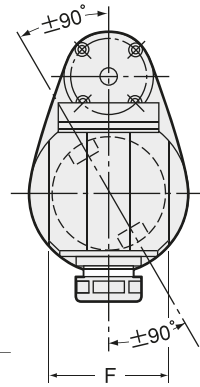
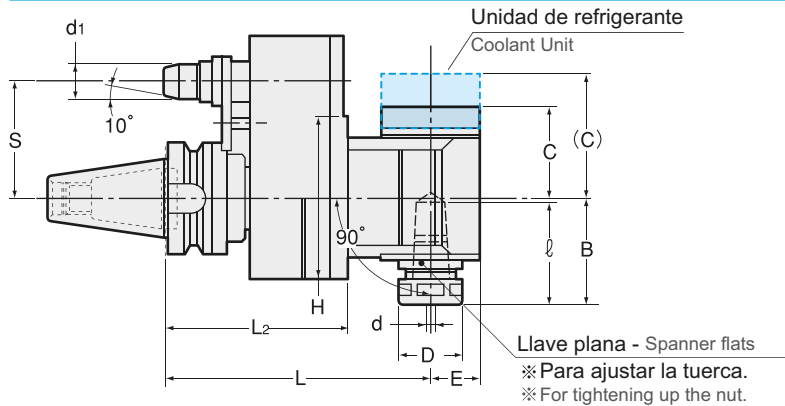

- Nuestro portaherramientas NBT de doble contacto es incompatible con el portaherramientas BT de doble contacto (para WBT-AHO). Por favor consultar pág. 50
- Cuando el modelo "AHO" es utilizado con alimentación de refrigerante que pasa a través del centro del portaherramienta, debe utilizarse un tornillo de retención diseñado para AHO (con pipa de refrigerante).
- Our two-face contact NBT spindle is incompatible with BT two-face contact spindle (for WBT-AHO). Please refer to p.50
- When AHO is used with center through coolant feeding, a designated retention stud (with coolant pipe) for AHO must be used.

※ Requiere de un bloque de posicionamiento. Favor de consultar la pág. 185-186.

※ Requires a positioning block. Please refer to P.185-186.

Unidad : Métrico
Unit : Metric

Código Code	Modelo Model	d	L	L2	ℓ	d1	D	B	C (C)	E	F	H	S		
3790 *00100 **	NBT-AHO30 or WBT-AHO30	-AH0790	-120-50- **	0.5 ~ 7.0	120	75.3	40	13	23	42	33	17	45	78	50
3790 *00200 **	NBT-AHO30 or WBT-AHO30	-AH1290	-125-50- **	2.5 ~ 12.0	125	75.3	63.5	13	32	58	44.5	22	47	78	50
3790 *00300 **	NBT-AHO40 or WBT-AHO40	-AH0790 (-AH0790-OH)	-150-65- **	0.5 ~ 7.0	150	103	40	19.6	23	42	33 (46.5)	17	51	90	65
3790 *00400 **			-180-65- **	0.5 ~ 7.0	180	103	40	19.6	23	42	33 (46.5)	17	51	90	65
3790 *00500 **			-210-65- **	0.5 ~ 7.0	210	103	40	19.6	23	42	33 (46.5)	17	51	90	65
3790 *00600 **			-240-65- **	0.5 ~ 7.0	240	120	40	19.6	23	42	33 (46.5)	17	51	90	65
3790 *00700 **			-270-65- **	0.5 ~ 7.0	270	120	40	19.6	23	42	33 (46.5)	17	51	90	65
3790 *00800 **	NBT-AHO40 or WBT-AHO40	-AH0990 (-AH0990-OH)	-150-65- **	2.5 ~ 9.0	150	103	55	19.6	26.3	53.5	44.5 (58.5)	22	58	90	65
3790 *00900 **			-180-65- **	2.5 ~ 9.0	180	103	55	19.6	26.3	53.5	44.5 (58.5)	22	58	90	65
3790 *01000 **			-210-65- **	2.5 ~ 9.0	210	103	55	19.6	26.3	53.5	44.5 (58.5)	22	58	90	65
3790 *01100 **			-240-65- **	2.5 ~ 9.0	240	120	55	19.6	26.3	53.5	44.5 (58.5)	22	58	90	65
3790 *01200 **	NBT-AHO40 or WBT-AHO40	-AH1690 (-AH1690-OH)	-150-65- **	3.5 ~ 16.0	150	103	59	19.6	36.3	59	51 (64.5)	28	67	90	65
3790 *01300 **			-180-65- **	3.5 ~ 16.0	180	103	59	19.6	36.3	59	51 (64.5)	28	67	90	65
3790 *01400 **			-210-65- **	3.5 ~ 16.0	210	103	59	19.6	36.3	59	51 (64.5)	28	67	90	65
3790 *01500 **	NBT-AHO50 or WBT-AHO50	-AH0790 (-AH0790-OH)	-165-80- **	0.5 ~ 7.0	165	118	40	28	23	42	33 (46.5)	17	51	90	80
3790 *01600 **			-195-80- **	0.5 ~ 7.0	195	118	40	28	23	42	33 (46.5)	17	51	90	80
3790 *01700 **			-225-80- **	0.5 ~ 7.0	225	118	40	28	23	42	33 (46.5)	17	51	90	80
3790 *01800 **			-255-80- **	0.5 ~ 7.0	255	135	40	28	23	42	33 (46.5)	17	51	90	80
3790 *01900 **			-285-80- **	0.5 ~ 7.0	285	135	40	28	23	42	33 (46.5)	17	51	90	80
3790 *02000 **			-165-110- **	0.5 ~ 7.0	165	118	40	28	23	42	33 (46.5)	17	51	90	110
3790 *02100 **			-195-110- **	0.5 ~ 7.0	195	118	40	28	23	42	33 (46.5)	17	51	90	110
3790 *02200 **			-225-110- **	0.5 ~ 7.0	225	118	40	28	23	42	33 (46.5)	17	51	90	110
3790 *02300 **			-255-110- **	0.5 ~ 7.0	255	135	40	28	23	42	33 (46.5)	17	51	90	110
3790 *02400 **			-285-110- **	0.5 ~ 7.0	285	135	40	28	23	42	33 (46.5)	17	51	90	110

Código Code	Modelo Model	d	L	L2	ℓ	d1	D	B	C (C)	E	F	H	S
3790 ※ 02500 ※※	NBT-AHO50 or WBT-AHO50 -AH0990 (-AH0990-OH) -165-80- ※※	2.5 ~ 9.0	165	118	55	28	26.3	53.5	44.5 (58.5)	22	58	90	80
3790 ※ 02600 ※※	-195-80- ※※	2.5 ~ 9.0	195	118	55	28	26.3	53.5	44.5 (58.5)	22	58	90	80
3790 ※ 02700 ※※	-225-80- ※※	2.5 ~ 9.0	225	118	55	28	26.3	53.5	44.5 (58.5)	22	58	90	80
3790 ※ 02800 ※※	-255-80- ※※	2.5 ~ 9.0	255	135	55	28	26.3	53.5	44.5 (58.5)	22	58	90	80
3790 ※ 02900 ※※	-165-110- ※※	2.5 ~ 9.0	165	118	55	28	26.3	53.5	44.5 (58.5)	22	58	90	110
3790 ※ 03000 ※※	-195-110- ※※	2.5 ~ 9.0	195	118	55	28	26.3	53.5	44.5 (58.5)	22	58	90	110
3790 ※ 03100 ※※	-225-110- ※※	2.5 ~ 9.0	225	118	55	28	26.3	53.5	44.5 (58.5)	22	58	90	110
3790 ※ 03200 ※※	-255-110- ※※	2.5 ~ 9.0	255	135	55	28	26.3	53.5	44.5 (58.5)	22	58	90	110
3790 ※ 03300 ※※	NBT-AHO50 or WBT-AHO50 -AH1690 (-AH1690-OH) -165-80- ※※	3.5 ~ 16.0	165	118	59	28	36.3	59	51 (64.5)	28	67	90	80
3790 ※ 03400 ※※	-195-80- ※※	3.5 ~ 16.0	195	118	59	28	36.3	59	51 (64.5)	28	67	90	80
3790 ※ 03500 ※※	-225-80- ※※	3.5 ~ 16.0	225	118	59	28	36.3	59	51 (64.5)	28	67	90	80
3790 ※ 03600 ※※	-165-110- ※※	3.5 ~ 16.0	165	118	59	28	36.3	59	51 (64.5)	28	67	90	110
3790 ※ 03700 ※※	-195-110- ※※	3.5 ~ 16.0	195	118	59	28	36.3	59	51 (64.5)	28	67	90	110
3790 ※ 03800 ※※	-225-110- ※※	3.5 ~ 16.0	225	118	59	28	36.3	59	51 (64.5)	28	67	90	110
3790 ※ 03900 ※※	NBT-AHO50 or WBT-AHO50 -AH2290 (-AH2290-OH) -180-80- ※※	3.5 ~ 22.0	180	117	65	28	46.3	69	57 (70.5)	34.5	75	113	80
3790 ※ 04000 ※※	-210-80- ※※	3.5 ~ 22.0	210	117	65	28	46.3	69	57 (70.5)	34.5	75	113	80
3790 ※ 04100 ※※	-240-80- ※※	3.5 ~ 22.0	240	117	65	28	46.3	69	57 (70.5)	34.5	75	113	80
3790 ※ 04200 ※※	-180-110- ※※	3.5 ~ 22.0	180	117	65	28	46.3	69	57 (70.5)	34.5	75	113	110
3790 ※ 04300 ※※	-210-110- ※※	3.5 ~ 22.0	210	117	65	28	46.3	69	57 (70.5)	34.5	75	113	110
3790 ※ 04400 ※※	-240-110- ※※	3.5 ~ 22.0	240	117	65	28	46.3	69	57 (70.5)	34.5	75	113	110
3790 ※ 04500 ※※	NBT-AHO50 or WBT-AHO50 -AH2590 (-AH2590-OH) -195-80- ※※	9.5 ~ 25.0	195	117	101	28	65	90	73 (86.5)	45	90	113	80
3790 ※ 04600 ※※	-195-110- ※※	9.5 ~ 25.0	195	117	101	28	65	90	73 (86.5)	45	90	113	110

Favor de reemplazar ※ en el código con Ø para el NBT-AHO y con 6 para el WBT-AHO.

Los nombres de modelos entre corchetes muestran "del tipo refrigerante" y se cotizan al solicitarlos.

- ※ es para la dimensión A. Favor de dirigirse a la pág. 185.
- Al hacer su orden, favor de especificar la medida del émbolo (dimensión "A").
- El émbolo está fijo (no es ajustable)
- La boquilla y la llave inglesa se venden por separado.
- ※※※ -AHO30-AH1290-125-50- ※※ es sólo para cortes ligeros.

Please replace ※ in the code with Ø for NBT-AHO and 6 for WBT-AHO.

Model names in brackets show "Coolant type", which are quoted on request.

- ※ is for A dimension. Please refer to P. 185.
- When ordering, please specify plunger size ("A" dimension).
- Plunger is fixed (non-adjustable)
- Collet and spanner are sold separately.
- ※※※ -AHO30-AH1290-125-50- ※※ is light cutting only.

Accesorios para el cabezal en ángulo del tipo fijo
Accessories for Angle heads fixed type

Modelo Model	Tuerca ciega Nut	Boquilla Collet	Llave inglesa para la tuerca Spanner for nut	Llave de boca para el cabezal Spanner flats for the head
AH0790	HDP-07A	FDC-07	S-0	Width 14mm
AH0990	HDP-09	FDC-09	S-1L	S-1L
AH1290	HDP-12	FDC-12	S-3L	S-3L
AH1690	HDP-16	FDC-16	S-4L	S-4L
AH2290	HDP-22	FDC-22	S-5L	S-5L
AH2590	HPP-25	NTG25	HS2.5-25	HS2.5-25

Ejemplo para Ordenar - Ordering Example

Correspondiente a nuestro zanco con contacto de doble cara BT

Corresponding to our two-face contact BT spindle

NBT-AHO40 - AH 07 90 - 150 - 65 - 06

Interfaz y diámetro de husillo	Máx. Diámetro Interno de boquilla	Angulo	Longitud de proyección	Dimensión A
Shank size	Max. collet I.D.	Angle	Projection length (L)	S Dimension A

Ejemplo para Ordenar - Ordering Example

Correspondiente al zanco con contacto de doble cara BT

Corresponding to BT two-face contact spindle

WBT-AHO40 - AH 07 90 - 150 - 65 - 06

Interfaz y diámetro de husillo	Máx. Diámetro Interno de boquilla	Angulo	Longitud de proyección	Dimensión A
Shank size	Max. collet I.D.	Angle	Projection length (L)	S Dimension A

Boquilla Collet
Pág. 090-093



Llave Inglesa Spanner
Pág. 099



BT
CAT
AHO
HSK-A/E/F/C
HSK-T
C
UTS
Máquinas Especializadas
Specialized Machine
Equipo Relacionado
Related Equipment
Taladro de Biselado y de Casquillo
Bush & Chamfering Drill
Milling Chuck
Collet Holder
"R" Zero Holder
Hydraulic Chuck
Shrink Fit
Tapping Chuck
Aftors
Function Holder
Retention Stud

AH , AH-OH

45°

Angle Heads (Fixed Type)

※ Se necesita un tornillo de retención AHO

※ AHO Retention Stud is required.

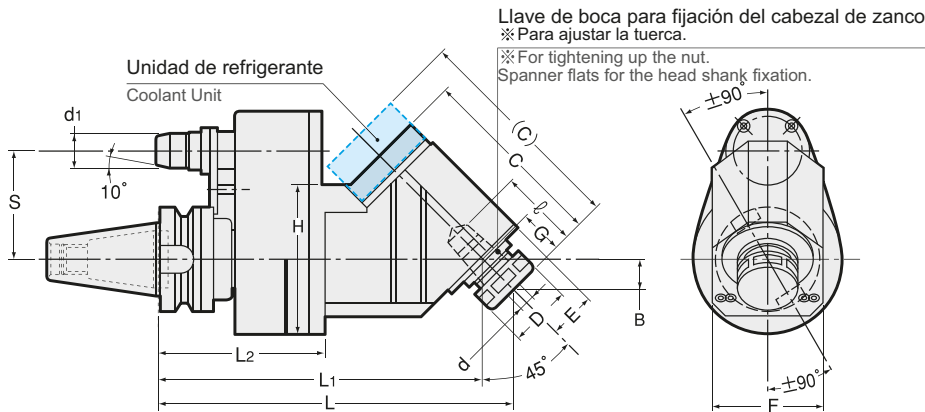

※ Requiere de un bloque de posicionamiento. Favor de consultar la pág. 185-186.

※ Requires a positioning block. Please refer to P.185-186.



- Nuestro portaherramientas NBT de doble contacto es incompatible con el portaherramientas BT de doble contacto (para WBT-AHO). Por favor consultar pág. 50
- Cuando el modelo "AHO" es utilizado con alimentación de refrigerante que pasa a través del centro del portaherramienta, debe utilizarse un tornillo de retención diseñado para AHO (con pipa de refrigerante).
- Our two-face contact NBT spindle is incompatible with BT two-face contact spindle (for WBT-AHO). Please refer to p.50
- When AHO is used with center through coolant feeding, a designated retention stud (with coolant pipe) for AHO must be used.

Unidad : Métrico
Unit : Metric

Código Code	Modelo Model	d	L	L1	L2	ℓ	d1	D	B	C (C)	E	F	G	H	S
3790 * 04800 ※※	NBT-AHO40 or WBT-AHO40 -AH0745(-OH)-195-65- ※※	0.5 ~ 7.0	195	179.5	103	35	19.6	23	15.6	88.5 (102)	17	51	22	90	65
3790 * 04900 ※※	-215-65- ※※	0.5 ~ 7.0	215	199.5	103	35	19.6	23	15.6	88.5 (102)	17	51	22	90	65
3790 * 05000 ※※	-245-65- ※※	0.5 ~ 7.0	245	229.5	103	35	19.6	23	15.6	88.5 (102)	17	51	22	90	65
3790 * 05100 ※※	NBT-AHO40 or WBT-AHO40 -AH945(-OH) -205-65- ※※	2.5 ~ 9.0	205	186.5	103	45	19.6	26.3	19.1	104 (118)	22	58	27	90	65
3790 * 05200 ※※	-230-65- ※※	2.5 ~ 9.0	230	211.5	103	45	19.6	26.3	19.1	104 (118)	22	58	27	90	65
3790 * 05300 ※※	-260-65- ※※	2.5 ~ 9.0	260	241.5	103	45	19.6	26.3	19.1	104 (118)	22	58	27	90	65
3790 * 05400 ※※	NBT-AHO40 or WBT-AHO40 -AH1645(-OH)-215-65- ※※	3.5 ~ 16.0	215	197	103	53	19.6	36.3	18.4	113.5 (127)	28	67	26	90	65
3790 * 05500 ※※	-245-65- ※※	3.5 ~ 16.0	245	227	103	53	19.6	36.3	18.4	113.5 (127)	28	67	26	90	65
3790 * 05600 ※※	NBT-AHO50 or WBT-AHO50 -AH0745(-OH) -210-80- ※※	0.5 ~ 7.0	210	194.5	118	35	28	23	15.6	88.5 (102)	17	51	22	90	80
3790 * 05700 ※※	-230-80- ※※	0.5 ~ 7.0	230	214.5	118	35	28	23	15.6	88.5 (102)	17	51	22	90	80
3790 * 05800 ※※	-260-80- ※※	0.5 ~ 7.0	260	244.5	118	35	28	23	15.6	88.5 (102)	17	51	22	90	80
3790 * 05900 ※※	-210-110- ※※	0.5 ~ 7.0	210	194.5	118	35	28	23	15.6	88.5 (102)	17	51	22	90	110
3790 * 06000 ※※	-230-110- ※※	0.5 ~ 7.0	230	214.5	118	35	28	23	15.6	88.5 (102)	17	51	22	90	110
3790 * 06100 ※※	-260-110- ※※	0.5 ~ 7.0	260	244.5	118	35	28	23	15.6	88.5 (102)	17	51	22	90	110

Código Code	Modelo Model	d	L	L1	L2	ℓ	d1	D	B	C (C)	E	F	G	H	S
3790 ※ 06200 ※※	NBT-AHO50 or WBT-AHO50 -AH0945(-OH)-220-80- ※※	2.5 ~ 9.0	220	201.5	118	45	28	26.3	19.1	104 (118)	22	58	27	90	80
3790 ※ 06300 ※※	-245-80- ※※	2.5 ~ 9.0	245	226.5	118	45	28	26.3	19.1	104 (118)	22	58	27	90	80
3790 ※ 06400 ※※	-275-80- ※※	2.5 ~ 9.0	275	256.5	118	45	28	26.3	19.1	104 (118)	22	58	27	90	80
3790 ※ 06500 ※※	-220-110- ※※	2.5 ~ 9.0	220	201.5	118	45	28	26.3	19.1	104 (118)	22	58	27	90	110
3790 ※ 06700 ※※	-245-110- ※※	2.5 ~ 9.0	245	226.5	118	45	28	26.3	19.1	104 (118)	22	58	27	90	110
3790 ※ 06800 ※※	-275-110- ※※	2.5 ~ 9.0	275	256.5	118	45	28	26.3	19.1	104 (118)	22	58	27	90	110
3790 ※ 06900 ※※	NBT-AHO50 or WBT-AHO50 -AH1645(-OH)-230-80- ※※	3.5 ~ 16.0	230	212	118	53	28	36.3	18.4	113.5 (127)	28	67	26	90	80
3790 ※ 07000 ※※	-260-80- ※※	3.5 ~ 16.0	260	242	118	53	28	36.3	18.4	113.5 (127)	28	67	26	90	80
3790 ※ 07100 ※※	-230-110- ※※	3.5 ~ 16.0	230	212	118	53	28	36.3	18.4	113.5 (127)	28	67	26	90	110
3790 ※ 07200 ※※	-260-110- ※※	3.5 ~ 16.0	260	242	118	53	28	36.3	18.4	113.5 (127)	28	67	26	90	110

Favor de reemplazar ※ en el código con Ø para el NBT-AHO y con 6 para el WBT-AHO.
Los nombres de modelos entre corchetes muestran "del tipo refrigerante" y se cotizan al solicitarlos.

- ※ es para la dimensión A. Favor de dirigirse a la pág. 185.
- Al hacer su orden, favor de especificar la medida del émbolo (dimensión "A").
- El émbolo está fijo (no es ajustable)
- La boquilla y la llave inglesa se venden por separado.

Please replace ※ in the code with Ø for NBT-AHO and 6 for WBT-AHO.
Model names in brackets show "Coolant type", which are quoted on request.

- ※ is for A dimension. Please refer to P. 185.
- When ordering, please specify plunger size ("A" dimension).
- Plunger is fixed (non-adjustable)
- Collet and spanner are sold separately.

Accesorios para el cabezal en ángulo del tipo fijo
Accessories for Angle heads fixed type

Modelo Model	Tuerca Nut	Boquilla Collet	Llave inglesa para la tuerca Spanner for nut	Llave de boca para el cabezal Spanner flats for the head
AH0745	HDP-07A	FDC-07	S-0	Anchura / Width 14mm
AH0945	HDP-09	FDC-09	S-1L	S-1L
AH1645	HDP-16	FDC-16	S-4L	S-4L

Ejemplo para Ordenar - Ordering Example

Correspondiente a nuestro zanco con contacto de doble cara BT
Corresponding to our two-face contact BT spindle

NBT-AHO40 - AH	07	45	- 195	- 65	- 06
Interfaz y diámetro de husillo	Máx. Diámetro Interno de boquilla	Longitud de proyección	S	Dimensión A	
Shank size	Max. collet I.D.	Projection length (L)	S	Dimension A	

Boquilla Collet
Pág. 090-093



Llave Inglesa Spanner
Pág. 099



Ejemplo para Ordenar - Ordering Example

Correspondiente al zanco con contacto de doble cara BT
Corresponding to BT two-face contact spindle

WBT-AHO40 - AH	07	45	- 195	- 65	- 06
Interfaz y diámetro de husillo	Máx. Diámetro Interno de boquilla	Longitud de proyección	S	Dimensión A	
Shank size	Max. collet I.D.	Projection length (L)	S	Dimension A	

Accesorios refrigerantes

Coolant Accessories

Dibujo del AHO con refrigerante por centro Drawing for AHO coolant through type

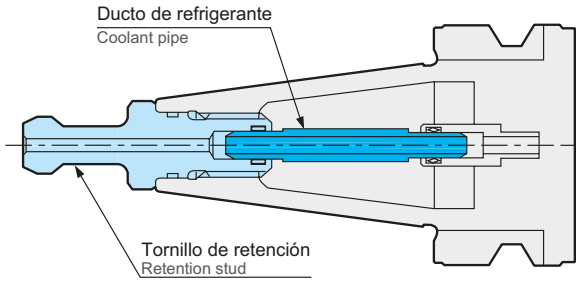

La boquilla AHO necesita un ducto de refrigerante y un perno de retención con alimentación de refrigerante por centro.
AHO holder requires a coolant pipe and a retention stud for center through coolant feed.

Tornillo de Retención Retention stud

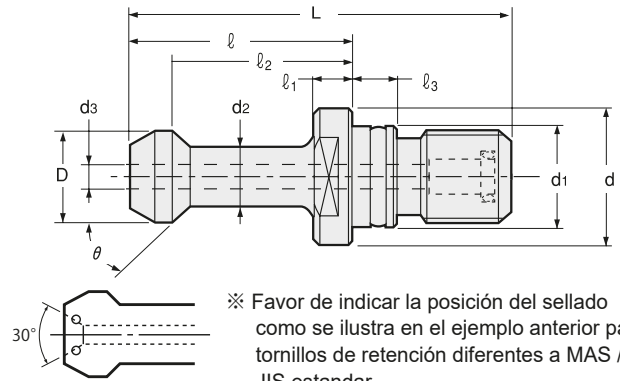

※ Favor de indicar la posición del sellado como se ilustra en el ejemplo anterior para tornillos de retención diferentes a MAS / JIS estándar.

※ For retention studs other than MAS / JIS standard, please indicate the position of the sealing as illustrated in the above example.

Código Code	Modelo Model	Zanco cónico Shank taper	Estándar Standard	D 0 -0.1	d ₁ h ₇	d ₂	L	ℓ	ℓ ₂	ℓ ₃	G	θ	Tipo Type	d ₃	θ ₂	—
3800 80000000	PSB-0-CH-AHO	30	MAS-1	11	12.5	7	43	23	18	5.5	M12	45°	1	2.5	—	6,000
3800 80000030	PSB-30P-AHO	30	JIS	12	12.5	8	43	23.4	18.4	6	M12	75°	1	4	—	6,000
3800 80000401	PSB-1T-AHO	30	—	11	12.5	8	43	23	18	5.5	M12	45°	1	4	—	6,000
3800 80000026	PSB-26-CH-AHO	30	—	11	12.5	7.5	43	23	18	5.5	M12	60°	1	2.5	—	6,000
3800 80000003	PSB-3-CH-AHO	40	MAS-1	15	17	10	60	35	28	7	M16	45°	1	4	—	6,000
3800 80000031	PSB-31-CH-AHO	40	MAS-1	15	17	10	60	35	28	7	M16	45°	3	3	30°	6,000
3800 80000004	PSB-4-CH-AHO	40	MAS-2	15	17	10	60	35	28	7	M16	60°	1	4	—	6,000
3800 80000038	PSB-38-CH-AHO	40	MAS-2	15	17	10	60	35	28	7	M16	60°	3	3	30°	6,000
3800 80000040	PSB-40P-AHO	40	JIS	19	17	14	54	29	23	7	M16	75°	1	7	—	6,000
3800 80000032	PSB-32-CH-AHO	40	JIS	19	17	14	54	29	23	7	M16	75°	1	4	—	6,000
3800 80000023	PSB-23-CH-AHO	40	—	18.8	17	12.5	44.1	19.1	14	5	M16	45°	1	7	—	6,000
3800 80000025	PSB-25-CH-AHO	40	—	19	17	14	54	29	23	7	M16	75°	3	7	30°	6,000
3800 80000007	PSB-7-CH-AHO	50	MAS-1	23	25	17	85	45	35	10	M24	45°	1	6	—	6,000
3800 80000033	PSB-33-CH-AHO	50	MAS-1	23	25	17	85	45	35	10	M24	45°	3	6	30°	6,000
3800 80000035	PSB-35-CH-AHO	50	MAS-1	23	25	17	85	45	35	10	M24	45°	3	5.5	60°	6,000
3800 80000008	PSB-8-CH-AHO	50	MAS-2	23	25	17	85	45	35	10	M24	60°	1	6	—	6,000
3800 80000036	PSB-36-CH-AHO	50	MAS-2	23	25	17	85	45	35	10	M24	60°	3	5.5	60°	6,000
3800 80000039	PSB-39-CH-AHO	50	MAS-2	23	25	17	85	45	35	10	M24	60°	3	6	30°	6,000
3800 80000050	PSB-50P-AHO	50	JIS	28	25	21	74	34	25	10	M24	75°	1	10	—	6,000
3800 80000037	PSB-37-CH-AHO	50	JIS	28	25	21	74	34	25	10	M24	75°	3	5.5	60°	6,000
3800 80000017	PSB-17-CH-AHO	50	—	24	25	18	71	31	23	10	M24	90°	1	6	—	6,000
3800 80000019	PSB-19-CH-AHO	50	—	23	25	17	85	45	35	10	M24	90°	1	6	—	6,000
3800 80000024	PSB-24-CH-AHO	50	—	29	25	20.9	65.2	25.2	17.6	8	M24	45°	1	10	—	6,000
3800 80000027	PSB-27-CH-AHO	50	—	23	25	17	85	45	35	10	M24	90°	3	8	30°	6,000

Se incluye un ducto de refrigerante en un tornillo de retención para AHO.
A coolant pipe is included in a retention stud for AHO.

Ducto de refrigerante Coolant pipe

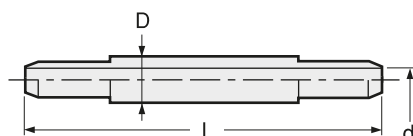

Código Code	Modelo Model	L	D	d	-
3800 60000030	CP-NBT30-OH	42	6	3	3,000
3800 60000040	CP-NBT40-OH	70	8	4	3,000
3800 60000050	CP-NBT50-OH	98	13	7	4,000

Ducto de refrigerante incluido.
A coolant pipe is included.



HSK

SISTEMA DE HERRAMENTADO HSK
HSK TOOLING SYSTEM

CT-SA

Super tite-lock Milling Chuck

- Super tite-lock Milling Chuck delgado. Sus ranuras tienen un diseño especial para permitir desbastes pesados.
- Slim design milling chuck. Specially designed slits enable heavy endmilling.

Tipo1
Type1

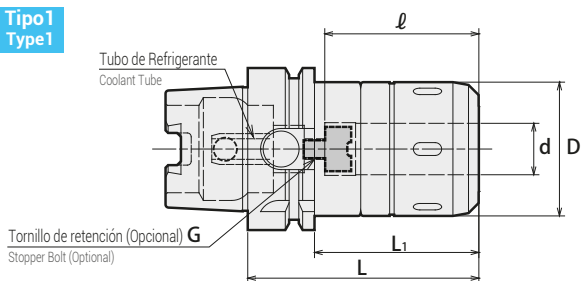

Tipo2
Type2

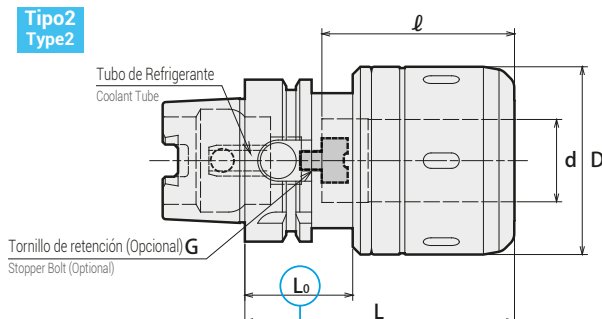

Tipo3
Type3

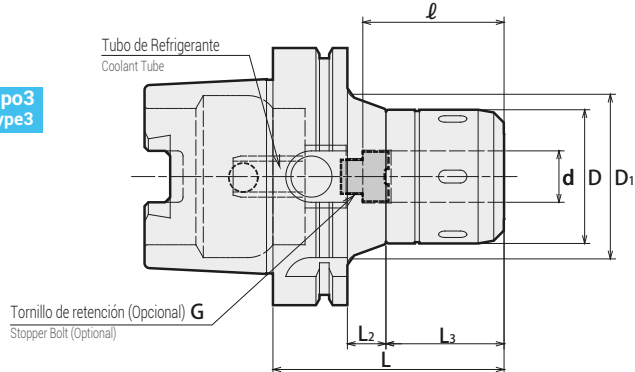

⚠ Precaución/Caution
 ★ : Tenga precaución con la interferencia del brazo A.T.C. (automatic tool changer) y el cartucho.
 Take caution against A.T.C. arm and tool magazine interference.

Precaución/Caution
 Favor de girar el anillo de sujeción en sentido contrario a las manecillas del reloj por más de 360 grados después de remover una herramienta de corte.
 Please rotate the clamping ring counterclockwise more than 360 degrees after a cutting tool is removed.

Medida en Pulgadas - Inch Sizes

Unidad : Pulgadas
Unit : Inch

Código Code	Modelo Model	Tipo Type	d	D	D ₁	L	L ₁	L ₂	L ₃	ℓ	L ₀	G P=1.0	Max. min ⁻¹	kg	Llave Inglesa Spanner
5690 13524090	HSK40A -CT0750SA -90	*2 2	0.750	2.047	-	3.543	-	-	-	2.362	1.378	M5	14,000	1	HS-1-16
5690 13532105	HSK40A -CT1000SA -105	*2 2	1.000	2.402	-	4.134	-	-	-	2.362	1.378	M5	10,000	1.6	HS-2.5-25
5690 75524090	HSK63A -CT0750SA -90 -H	*2 1	0.750	2.047	-	3.543	2.520	-	-	2.362	-	M8	18,000	1.5	HS-1-16
5690 75524105	-105 -H	*2 1	0.750	2.047	-	4.134	3.110	-	-	2.953	-	M8	18,000	1.7	
5690 75524135	-135 -H	*2 1	0.750	2.047	-	5.315	4.291	-	-	3.150	-	M8	18,000	2.2	
5690 75532105	HSK63A -CT1000SA -105 -H	*2 2	1.000	2.402	-	4.134	-	-	-	2.953	1.654	M8	16,000	2	HS-2.5-25
5690 75532120	-120 -H	*2 2	1.000	2.402	-	4.724	-	-	-	2.953	1.654	M8	16,000	2.3	
5690 75532135	-135 -H	*2 2	1.000	2.402	-	5.315	-	-	-	3.150	1.654	M8	15,000	2.7	
5690 75540105	HSK63A -CT1250SA -105 -H	*2 2	1.250	2.874	-	4.134	-	-	-	2.953	1.654	M8	12,000	2.4	HS-3-32
5690 75540120	-120 -H	*2 2	1.250	2.874	-	4.724	-	-	-	3.543	1.654	M8	12,000	2.7	
5690 75540150	-150 -H	*2 2	1.250	2.874	-	5.906	-	-	-	4.724	1.654	M8	12,000	3.5	
5690 77524090	HSK100A -CT0750SA -90 -H	*1 3	0.750	2.047	2.913	3.543	-	0.630	1.772	2.165	-	M10	12,500	2.9	HS-1-16
5690 77524105	-105 -H	3	0.750	2.047	2.913	4.134	-	1.220	1.772	2.756	-	M10	12,500	3.3	
5690 77524135	-135 -H	3	0.750	2.047	2.913	5.315	-	2.402	1.772	3.150	-	M10	12,500	3.7	
5690 77524150	-150 -H	3	0.750	2.047	2.913	5.906	-	2.992	1.772	3.150	-	M10	12,500	4.1	
5690 77532090	HSK100A -CT1000SA -90 -H	*1 1	1.000	2.402	-	3.543	2.402	-	-	2.165	-	M10	12,500	3.1	HS-2.5-25
5690 77532105	-105 -H	3	1.000	2.402	2.913	4.134	-	0.787	2.205	2.756	-	M10	12,500	3.5	
5690 77532135	-135 -H	3	1.000	2.402	2.913	5.315	-	1.969	2.205	3.150	-	M10	12,500	4.3	
5690 77532150	-150 -H	3	1.000	2.402	2.913	5.906	-	2.559	2.205	3.150	-	M10	12,500	4.7	
5690 77540090	HSK100A -CT1250SA -90 -H	*1 1	1.250	2.874	-	3.543	2.402	-	-	2.165	-	M10	12,000	3.6	HS-3-32
5690 77540105	-105 -H	*2 1	1.250	2.874	-	4.134	2.992	-	-	2.756	-	M10	12,000	4	
5690 77540105	-120 -H	*2 1	1.250	2.874	-	4.724	3.583	-	-	3.346	-	M10	12,000	4.4	
5690 77540135	-135 -H	*2 1	1.250	2.874	-	5.315	4.173	-	-	3.937	-	M10	12,000	4.8	
5690 77540150	-150 -H	*2 1	1.250	2.874	-	5.906	4.764	-	-	4.528	-	M10	12,000	5.2	

Medidas Métricas - Metric Sizes Unidad : Métrico
Unit : Metric

Código Code	Modelo Model	Tipo Type	d	D	D ₁	L	L ₁	L ₂	L ₃	ℓ	L ₀	G	Max. min ⁻¹	kg	—	Llave Inglesa Spanner	
5690 13416075	HSK40A -CT16SA - 75	* 1	2	16	45	—	75	—	—	—	50	★ 26	M5	16,000	0.8	41,000	HS-1-16
5690 13416090	- 90	* 1	2	16	45	—	90	—	—	—	60	35	M5	16,000	0.9	41,000	
5690 13420090	-CT20SA - 90	* 2	2	20	52	—	90	—	—	—	60	35	M5	14,000	1.0	41,000	HS-2-20
5690 13420105	- 105	* 2	2	20	52	—	105	—	—	—	60	35	M5	12,000	1.3	43,000	
5690 13425105	-CT25SA - 105	* 2	2	25	61	—	105	—	—	—	60	35	M5	10,000	1.6	44,000	HS-2.5-25
5690 14416090	HSK50A -CT16SA - 90	* 1	2	16	45	—	90	—	—	—	60	42	M5	20,000	1.1	42,000	
5690 14420090	-CT20SA - 90	* 2	2	20	52	—	90	—	—	—	60	42	M5	18,000	1.2	44,000	HS-2-20
5690 14420105	- 105	* 2	2	20	52	—	105	—	—	—	60	42	M5	17,000	1.5	45,000	
5690 14425105	-CT25SA - 105	* 1	2	25	61	—	105	—	—	—	75	42	M5	15,000	1.7	46,000	HS-2.5-25
5690 75416075	HSK63A -CT16SA - 75 -H	* 2	1	16	45	—	75	49	—	—	47	—	M8	20,500	1.2	44,000	
5690 75416090	- 90 -H		1	16	45	—	90	64	—	—	60	—	M8	20,500	1.4	44,000	HS-1-16
5690 75420090	-CT20SA - 90 -H	* 2	1	20	52	—	90	64	—	—	60	—	M8	18,000	1.6	46,000	
5690 75420105	- 105 -H	* 1	1	20	52	—	105	79	—	—	75	—	M8	18,000	1.8	48,000	HS-2-20
5690 75420135	- 135 -H	* 1	1	20	52	—	135	109	—	—	80	—	M8	18,000	2.3	49,000	
5690 75425105	-CT25SA - 105 -H	* 1	2	25	61	—	105	—	—	—	75	42	M8	16,000	2.1	49,000	HS-2.5-25
5690 75425120	- 120 -H	* 1	2	25	61	—	120	—	—	—	75	42	M8	16,000	2.4	49,000	
5690 75425135	- 135 -H	* 1	2	25	61	—	135	—	—	—	80	42	M8	15,000	2.7	49,000	
5690 75432105	-CT32SA - 105 -H	* 3	2	32	73	—	105	—	—	—	75	42	M8	12,000	2.5	52,000	HS-3-32
5690 75432120	- 120 -H	* 3	2	32	73	—	120	—	—	—	90	42	M8	12,000	2.8	52,000	
5690 75432150	- 150 -H	* 1	2	32	73	—	150	—	—	—	120	42	M8	12,000	3.6	53,000	
5690 77416090	HSK100A -CT16SA - 90 -H	* 2	3	16	45	56	90	—	16	45	55	—	M10	12,500	2.8	59,400	HS-1-16
5690 77416105	- 105 -H		3	16	45	56	105	—	31	45	70	—	M10	12,500	3.0	59,400	
5690 77420090	-CT20SA - 90 -H	* 6	3	20	52	64	90	—	16	45	55	—	M10	12,500	3.0	59,400	HS-2-20
5690 77420105	- 105 -H	* 4	3	20	52	64	105	—	18	58	70	—	M10	12,500	3.3	61,600	
5690 77420120	- 120 -H		3	20	52	64	120	—	33	58	80	—	M10	12,500	3.5	61,600	
5690 77420135	- 135 -H		3	20	52	64	135	—	48	58	80	—	M10	12,500	3.9	61,600	
5690 77420150	- 150 -H		3	20	52	64	150	—	63	58	80	—	M10	12,500	4.1	62,700	
5690 77425090	HSK100A -CT25SA - 90 -H	* 6	1	25	61	—	90	61	—	—	55	—	M10	12,500	3.2	66,000	HS-2.5-25
5690 77425105	- 105 -H	* 5	3	25	61	74	105	—	20	56	70	—	M10	12,500	3.6	66,000	
5690 77425120	- 120 -H		3	25	61	74	120	—	35	56	80	—	M10	12,500	4.0	66,000	
5690 77425135	- 135 -H		3	25	61	74	135	—	50	56	80	—	M10	12,500	4.4	66,000	
5690 77425150	- 150 -H		3	25	61	73	150	—	65	56	80	—	M10	12,500	4.8	67,100	
5690 77432090	-CT32SA - 90 -H	* 6	1	32	73	—	90	61	—	—	55	—	M10	12,000	3.6	67,100	HS-3-32
5690 77432105	- 105 -H	* 2	1	32	73	—	105	76	—	—	70	—	M10	12,000	4.1	67,100	
5690 77432120	- 120 -H	* 3	1	32	73	—	120	91	—	—	85	—	M10	12,000	4.5	67,100	
5690 77432135	- 135 -H	* 1	1	32	73	—	135	106	—	—	100	—	M10	12,000	5.0	67,100	
5690 77432150	- 150 -H	* 1	1	32	73	—	150	121	—	—	115	—	M10	12,000	5.3	68,200	
5690 77442105	-CT42SA - 105 -H	* 6	2	42	88	—	105	—	—	—	70	45	M10	10,000	4.8	68,200	HS-4-42
5690 77442120	- 120 -H	* 2	2	42	88	—	120	—	—	—	85	45	M10	10,000	5.4	70,400	
5690 77442135	- 135 -H	* 2	2	42	88	—	135	—	—	—	100	45	M10	10,000	5.9	78,100	
5690 77442150	- 150 -H	* 2	2	42	88	—	150	—	—	—	110	45	M10	10,000	6.5	78,100	
5690 77442165	- 165 -H	* 1	2	42	88	—	165	—	—	—	120	45	M10	10,000	7.1	79,200	

HSK63A, HSK100A incluyen barreno de cambio manual en el zanco.
 HSK63A, HSK100A have manual clamp holes in the shank.

- Al hacer su orden, indique el número de llaves inglesas que requiere. Las llaves inglesas "son gratuitas" y están limitadas al número de portaherramientas de fresado de su orden.
 - La tolerancia del zanco de las herramientas de corte deben estar dentro de h7.
 - La velocidad permitida varía mucho según la rigidez del husillo en la máquina y del balance de la herramienta de corte.
 Aumente gradualmente la velocidad a partir de la baja y úselo en la velocidad adecuada.
- When ordering, indicate number of spanners required. "Complimentary" spanners are limited to number of milling chucks on order.
 - Tolerance of cutting tool shank must be h7.
 - Permissible speed is greatly affected by the stiffness of the machine spindle and the balance of the cutting tool.
 Gradually increase from a low speed, and use at the proper speed.

Ejemplo para Ordenar - Ordering Example

HSK40A -CT 16 SA- 75

Interfaz y diámetro de husillo Diámetro Interior Longitud de Proyección
 Shank size I.D. Projection length

Ejemplo para Ordenar - Ordering Example

HSK63A -CT 16 SA- 75 - H





Interfaz y diámetro de husillo Diámetro Interior Longitud de Proyección Barreno de Cambio Manual
 Shank size I.D. Projection length Manual clamping hole



BT
 CAT
 AHO
 HSK-AE/FC
 HSK-T
 C
 UTS
 Máquinas Especializadas
 Specialized Machine
 Equipo Relacionado
 Related Equipment
 Taladro de Biselado & de Casquillo
 Bush & Chamfering Drill
 Milling Chuck
 Collet Holder
 "R" Zero Holder
 Hydraulic Chuck
 Shrink Fit
 Tapping Chuck
 Aftors
 Function Holder
 HSK-E
 HSK-F
 HSK-C
 Dimensions

Accesorios
Accessories

Los modelos con * 1- * 6 no pueden usarse con algunos accesorios debido a la corta l longitud.
Models with * 1 - * 6 cannot be used with some accessories due to short l length.

	Tornillo de retención Stopper Bolt 	Boquilla recta Straight Collet 		Adaptador ahusado Morse Morse Taper Adapter 		Adaptador Jacobs Jacobs Adapter 	
		BL (Pág.72)	MC (Pág.070)	MCA (Pág.071)	MA (Pág.072)	MAB (Pág.072)	JA (Pág.073)
* 1	○	○	×	○	○	○	○
* 2	○	○	×	×	×	×	×
* 3	○	○	×	×	○	×	○
* 4	○	○	○	○	×	○	×
* 5	○	○	○	×	×	○	×
* 6	○	×	×	×	×	×	×

Longitud Mínima de inserción
Min. chucking length

Sin boquilla MC - Without MC collet

D.I. del portaherramienta de fresado I.D. of Milling Chuck	Longitud mín de inserción Min. chucking length
16, 20	40
25, 32, 42	50

Con boquilla MC - With MC collet

D.I. de la boquilla Collet I.D.	Longitud mín de inserción Min. chucking length	
	MC	MC-C, MC-OH
6, 8	30	30
10, 12	40	40
16, 20	45	45
25	50	50
32	50	60

Sin boquilla MC - Without MC collet

D.I. del portaherramienta de fresado I.D. of Milling Chuck	Longitud mín de inserción Min. chucking length
16mm, 20mm	40mm (1.575")
25mm, 32mm, 42mm	50mm (1.969")

Con boquilla MC - With MC collet

D.I. de la boquilla Collet I.D.	Longitud mín de inserción Min. chucking length	
	MC	MC-C, MC-OH
6mm, 8mm	30mm (1.181")	30mm (1.181")
10mm, 12mm	40mm (1.575")	40mm (1.575")
16mm, 18mm, 20mm	45mm (1.772")	45mm (1.772")
25mm	50mm (1.969")	50mm (1.969")
32mm	50mm (1.969")	60mm (2.362")

Llave Inglesa
Spanner
Pág. 073



BT
CAT
AHO

HSK-A/E/F/C

HSK-T

C

UTS

Máquinas Especializadas
Specialized Machine

Equipo Relacionado
Related Equipment

Taladro de Biselado & de Casquillo
Bush & Chamfering Drill

Milling Chuck
Collet Holder

"R" Zero Holder

Hydraulic Chuck

Shrink Fit

Tapping Chuck

Apbors

Function Holder

HSK-E

HSK-F

HSK-C

Dimensions

Tornillo de retención
Stopper Bolt (para/for HSK)

HSK-BL

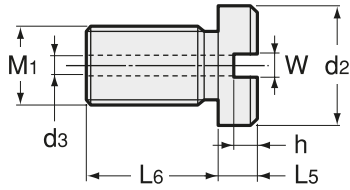

Código Code	Modelo Model	M1	L5	L6	W	h	d2	d3	Interfaz y diámetro de husillo Shank size
5691 040040 ※※	HSK40 -BL -L5	M5 P=0.8	5, 15, 25	8.5	5	2.5	13	2.5	HSK40A, HSK50A
5691 04006305	HSK63 -BL -5	M8 P=1.25	5	5.5	5	3	15	4	HSK63A
5691 040063 ※※	HSK63 -BL -L5	M8 P=1.25	15, 25	7.5	5	3	15	4	HSK63A
5691 040100 ※※	HSK100 -BL -L5	M10 P=1.5	5, 15, 25	14	5	3.5	15	4.5	HSK100A

Elija la dimensión L5 correcta al revisar la longitud mínima de inserción y la profundidad del D.I. Del zanco.

Choose right L5 dimension by checking minimum insertion length and shank I.D. depth.

Ejemplo para Ordenar - Ordering Example

HSK63 - BL - 15

Interfaz y diámetro de husillo	L5
Shank Size	L5

HDC-A

High-Precision Collet Holder

- Adecuado para barrenado, rima y acabado en fresa.
- Suitable for drilling, reaming and finish endmilling.

Tipo1
Type1

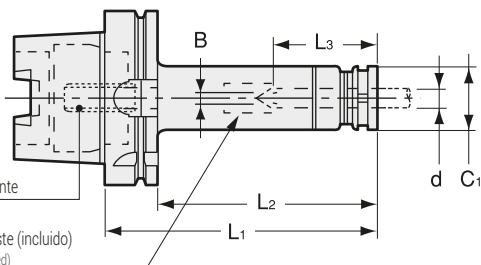

Tipo2
Type2

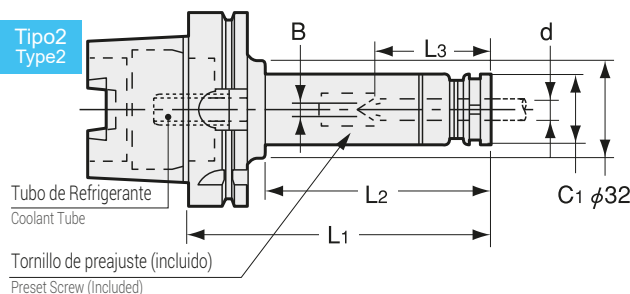

Tipo3
Type3

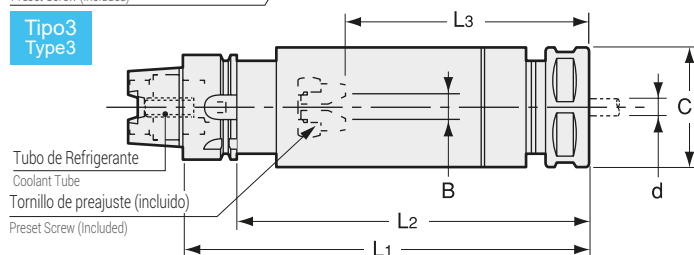



Unidad : Métrico
Unit : Metric

Código Code	Modelo Model	Tipo Type	d	L1	L2	B	L3	C1	Tuerca ciega Nut	kg	Boquilla Collet	Llave Inglesa Spanner
5360 13107060	HSK40A -HDC07A -60	1	0.5 ~ 7.0	60	40	0 ~ 4	22 ~ 27	23	HDP-07A	0.4	FDC-07	S-0
5360 13107075	-75	1	0.5 ~ 7.0	75	55	0 ~ 4	22 ~ 38	23	HDP-07A	0.4		
5360 13107090	-90	1	0.5 ~ 7.0	90	70	0 ~ 4	22 ~ 49	23	HDP-07A	0.4		
5360 13107120	-120	1	0.5 ~ 7.0	120	100	0 ~ 4	22 ~ 49	23	HDP-07A	0.5		
5360 13107150	-150	1	0.5 ~ 7.0	150	130	0 ~ 4	22 ~ 49	23	HDP-07A	0.6		
5360 13109060	HSK40A -HDC09A -60	1	2.5 ~ 9.0	60	40	—	40	26	HDP-09	0.4	FDC-09	S-1L
5360 13109075	-75	1	2.5 ~ 9.0	75	55	0 ~ 4	27 ~ 35	26	HDP-09	0.4		
5360 13109090	-90	1	2.5 ~ 9.0	90	70	0 ~ 4	27 ~ 46	26	HDP-09	0.5		
5360 13109120	-120	1	2.5 ~ 9.0	120	100	0 ~ 4	27 ~ 61	26	HDP-09	0.6		
5360 13109150	-150	1	2.5 ~ 9.0	150	130	0 ~ 4	27 ~ 61	26	HDP-09	0.7		
5360 13112075	HSK40A -HDC12A -75	1	2.5 ~ 12.0	75	55	0 ~ 5	33 ~ 34	32	HDP-12	0.5	FDC-12	S-3L
5360 13112090	-90	1	2.5 ~ 12.0	90	70	0 ~ 5	33 ~ 51	32	HDP-12	0.6		
5360 13112120	-120	1	2.5 ~ 12.0	120	100	0 ~ 5	33 ~ 74	32	HDP-12	0.7		
5360 13112150	-150	1	2.5 ~ 12.0	150	130	0 ~ 5	33 ~ 74	32	HDP-12	0.9		
5360 13116075	HSK40A -HDC16A -75	3	3.5 ~ 16.0	75	55	0 ~ 6	38 ~ 40	36	HDP-16	0.5	FDC-16	S-4L
5360 13116090	-90	3	3.5 ~ 16.0	90	70	0 ~ 6	38 ~ 54	36	HDP-16	0.6		
5360 13116120	-120	3	3.5 ~ 16.0	120	100	0 ~ 6	38 ~ 72	36	HDP-16	0.8		
5360 13116150	-150	3	3.5 ~ 16.0	150	130	0 ~ 6	38 ~ 86	36	HDP-16	1.0		
5360 13122090	HSK40A -HDC22A -90	3	3.5 ~ 22.0	90	70	—	65	46	HDP-22	0.7	FDC-22	S-5L
5360 13122120	-120	3	3.5 ~ 22.0	120	100	0 ~ 8	47 ~ 73	46	HDP-22	1.0		
5360 13122150	-150	3	3.5 ~ 22.0	150	130	0 ~ 8	47 ~ 103	46	HDP-22	1.4		
5360 14107075	HSK50A -HDC07A -75	1	0.5 ~ 7.0	75	49	0 ~ 4	22 ~ 32	23	HDP-07A	0.6	FDC-07	S-0
5360 14107090	-90	1	0.5 ~ 7.0	90	64	0 ~ 4	22 ~ 45	23	HDP-07A	0.6		
5360 14107120	-120	1	0.5 ~ 7.0	120	94	0 ~ 4	22 ~ 45	23	HDP-07A	0.7		
5360 14109075	HSK50A -HDC09A -75	1	2.5 ~ 9.0	75	49	0 ~ 4	27 ~ 31	26	HDP-09	0.6	FDC-09	S-1L
5360 14109090	-90	1	2.5 ~ 9.0	90	64	0 ~ 4	27 ~ 47	26	HDP-09	0.6		
5360 14109120	-120	1	2.5 ~ 9.0	120	94	0 ~ 4	27 ~ 61	26	HDP-09	0.8		
5360 14112090	HSK50A -HDC12A -90	1	2.5 ~ 12.0	90	64	0 ~ 5	33 ~ 42	32	HDP-12	0.7	FDC-12	S-3L
5360 14112120	-120	1	2.5 ~ 12.0	120	94	0 ~ 5	33 ~ 71	32	HDP-12	0.9		
5360 14112150	-150	1	2.5 ~ 12.0	150	124	0 ~ 5	33 ~ 74	32	HDP-12	1.1		
5360 14116090	HSK50A -HDC16A -90	1	3.5 ~ 16.0	90	64	0 ~ 6	38 ~ 50	36	HDP-16	0.8	FDC-16	S-4L
5360 14116120	-120	1	3.5 ~ 16.0	120	94	0 ~ 6	38 ~ 65	36	HDP-16	1.0		
5360 14116150	-150	1	3.5 ~ 16.0	150	124	0 ~ 6	38 ~ 86	36	HDP-16	1.2		
5360 14122090	HSK50A -HDC22A -90	3	3.5 ~ 22.0	90	64	—	60	46	HDP-22	0.9	FDC-22	S-5L
5360 14122120	-120	3	3.5 ~ 22.0	120	94	0 ~ 8	47 ~ 63	46	HDP-22	1.2		
5360 14122150	-150	3	3.5 ~ 22.0	150	124	0 ~ 8	47 ~ 93	46	HDP-22	1.5		

Código Code	Modelo Model	Tipo Type	d	L1	L2	B	L3	C1	Tuerca ciega Nut	kg	Boquilla Collet	Llave Inglesa Spanner
5360 75107075	HSK63A -HDC07A -75-H	1	0.5 ~ 7.0	75	49	0 ~ 4	22 ~ 35	23	HDP-07A	0.8	FDC-07	S-0
5360 75107090	-90-H	1	0.5 ~ 7.0	90	64	0 ~ 4	22 ~ 45	23	HDP-07A	0.9		
5360 75107120	-120-H	1	0.5 ~ 7.0	120	94	0 ~ 4	22 ~ 45	23	HDP-07A	1.0		
5360 75107150	-150-H	1	0.5 ~ 7.0	150	124	0 ~ 4	22 ~ 45	23	HDP-07A	1.0		
5360 75107180	-180-H	1	0.5 ~ 7.0	180	154	0 ~ 4	22 ~ 45	23	HDP-07A	1.1		
5360 75109075	HSK63A -HDC09A -75-H	1	2.5 ~ 9.0	75	49	0 ~ 4	27 ~ 34	26	HDP-09	0.9	FDC-09	S-1L
5360 75109090	-90-H	1	2.5 ~ 9.0	90	64	0 ~ 4	27 ~ 42	26	HDP-09	0.9		
5360 75109120	-120-H	1	2.5 ~ 9.0	120	94	0 ~ 4	27 ~ 57	26	HDP-09	1.0		
5360 75109150	-150-H	1	2.5 ~ 9.0	150	124	0 ~ 4	27 ~ 57	26	HDP-09	1.1		
5360 75109180	-180-H	1	2.5 ~ 9.0	180	154	0 ~ 4	27 ~ 57	26	HDP-09	1.2		
5360 75112075	HSK63A -HDC12A -75-H	1	2.5 ~ 12.0	75	49	—	48	32	HDP-12	1.0	FDC-12	S-3L
5360 75112090	-90-H	1	2.5 ~ 12.0	90	64	0 ~ 5	33 ~ 48	32	HDP-12	1.1		
5360 75112120	-120-H	1	2.5 ~ 12.0	120	94	0 ~ 5	33 ~ 69	32	HDP-12	1.3		
5360 75112150	-150-H	1	2.5 ~ 12.0	150	124	0 ~ 5	33 ~ 69	32	HDP-12	1.4		
5360 75112180	-180-H	1	2.5 ~ 12.0	180	154	0 ~ 5	33 ~ 69	32	HDP-12	1.6		
5360 75112210	-210-H	1	2.5 ~ 12.0	210	184	0 ~ 5	33 ~ 69	32	HDP-12	1.8		
5360 75116075	HSK63A -HDC16A -75-H	1	3.5 ~ 16.0	75	49	—	48	36	HDP-16	1.0	FDC-16	S-4L
5360 75116090	-90-H	1	3.5 ~ 16.0	90	64	0 ~ 6	38 ~ 48	36	HDP-16	1.1		
5360 75116120	-120-H	1	3.5 ~ 16.0	120	94	0 ~ 6	38 ~ 62	36	HDP-16	1.3		
5360 75116150	-150-H	1	3.5 ~ 16.0	150	124	0 ~ 6	38 ~ 82	36	HDP-16	1.4		
5360 75116180	-180-H	1	3.5 ~ 16.0	180	154	0 ~ 6	38 ~ 82	36	HDP-16	1.6		
5360 75116210	-210-H	1	3.5 ~ 16.0	210	184	0 ~ 6	38 ~ 82	36	HDP-16	1.8		
5360 75122090	HSK63A -HDC22A -90-H	1	3.5 ~ 22.0	90	64	—	63	46	HDP-22	1.2	FDC-22	S-5L
5360 75122120	-120-H	1	3.5 ~ 22.0	120	94	0 ~ 8	47 ~ 63	46	HDP-22	1.5		
5360 75122150	-150-H	1	3.5 ~ 22.0	150	124	0 ~ 8	47 ~ 93	46	HDP-22	1.8		
5360 75122180	-180-H	1	3.5 ~ 22.0	180	154	0 ~ 8	47 ~ 103	46	HDP-22	2.2		
5360 75122210	-210-H	1	3.5 ~ 22.0	210	184	0 ~ 8	47 ~ 103	46	HDP-22	2.5		
5360 77107075	HSK100A -HDC07A -75-H	2	0.5 ~ 7.0	75	36	0 ~ 4	22 ~ 27	23	HDP-07A	2.2	FDC-07	S-0
5360 77107090	-90-H	2	0.5 ~ 7.0	90	51	0 ~ 4	22 ~ 45	23	HDP-07A	2.4		
5360 77107120	-120-H	2	0.5 ~ 7.0	120	81	0 ~ 4	22 ~ 45	23	HDP-07A	2.4		
5360 77107150	-150-H	2	0.5 ~ 7.0	150	111	0 ~ 4	22 ~ 45	23	HDP-07A	2.4		
5360 77107180	-180-H	2	0.5 ~ 7.0	180	141	0 ~ 4	22 ~ 45	23	HDP-07A	2.5		
5360 77109075	HSK100A -HDC09A -75-H	2	2.5 ~ 9.0	75	36	0 ~ 4	27	26	HDP-09	2.3	FDC-09	S-1L
5360 77109090	-90-H	2	2.5 ~ 9.0	90	51	0 ~ 4	27 ~ 43	26	HDP-09	2.3		
5360 77109120	-120-H	2	2.5 ~ 9.0	120	81	0 ~ 4	27 ~ 57	26	HDP-09	2.4		
5360 77109150	-150-H	2	2.5 ~ 9.0	150	111	0 ~ 4	27 ~ 57	26	HDP-09	2.5		
5360 77109180	-180-H	2	2.5 ~ 9.0	180	141	0 ~ 4	27 ~ 57	26	HDP-09	2.6		
5360 77112090	HSK100A -HDC12A -90-H	1	2.5 ~ 12.0	90	61	0 ~ 5	33 ~ 41	32	HDP-12	2.4	FDC-12	S-3L
5360 77112120	-120-H	1	2.5 ~ 12.0	120	91	0 ~ 5	33 ~ 59	32	HDP-12	2.5		
5360 77112150	-150-H	1	2.5 ~ 12.0	150	121	0 ~ 5	33 ~ 69	32	HDP-12	2.7		
5360 77112180	-180-H	1	2.5 ~ 12.0	180	151	0 ~ 5	33 ~ 69	32	HDP-12	2.8		
5360 77112210	-210-H	1	2.5 ~ 12.0	210	181	0 ~ 5	33 ~ 69	32	HDP-12	3.0		
5360 77116090	HSK100A -HDC16A -90-H	1	3.5 ~ 16.0	90	61	0 ~ 6	38 ~ 41	36	HDP-16	2.4	FDC-16	S-4L
5360 77116120	-120-H	1	3.5 ~ 16.0	120	91	0 ~ 6	38 ~ 62	36	HDP-16	2.6		
5360 77116150	-150-H	1	3.5 ~ 16.0	150	121	0 ~ 6	38 ~ 82	36	HDP-16	2.8		
5360 77116180	-180-H	1	3.5 ~ 16.0	180	151	0 ~ 6	38 ~ 82	36	HDP-16	3.0		
5360 77116210	-210-H	1	3.5 ~ 16.0	210	181	0 ~ 6	38 ~ 82	36	HDP-16	3.2		
5360 77122090	HSK100A -HDC22A -90-H	1	3.5 ~ 22.0	90	61	—	56	46	HDP-22	2.6	FDC-22	S-5L
5360 77122120	-120-H	1	3.5 ~ 22.0	120	91	0 ~ 8	47 ~ 59	46	HDP-22	2.9		
5360 77122150	-150-H	1	3.5 ~ 22.0	150	121	0 ~ 8	47 ~ 83	46	HDP-22	3.2		
5360 77122180	-180-H	1	3.5 ~ 22.0	180	151	0 ~ 8	47 ~ 103	46	HDP-22	3.5		
5360 77122210	-210-H	1	3.5 ~ 22.0	210	181	0 ~ 8	47 ~ 103	46	HDP-22	3.8		

- La boquilla, llave inglesa, tornillo Allen opresor de preajuste y el tornillo de preajuste para procesos semisecos se venden por separado. El tornillo estándar de preajuste está incluido.
- Consulte la pág.096 para conocer la longitud mínima para insertar herramientas en caso de usar nuestras boquillas refrigerantes (OH, C o MS).
- L3 indica la dimensión al usarlo con un tornillo de preajuste.
- Consulte la pág. 521 para conocer el Torque recomendado en nuestros productos.

- Collet, spanner, hexagon head preset screw, preset screw for semi-dry processing are sold separately. Standard preset screw is included.
- Refer to P.096 for minimum tool insertion length in case of using our coolant collets (OH,C or MS).
- L3 indicates dimension when using with a preset screw.
- See P.521 for standard Tightening Torque.

Boquilla Collet Pág. 090-093	Llave Inglesa Spanner Pág. 099	Unidad preajustada Preset screw Pág. 098	Ejemplo para Ordenar - Ordering Example HSK63A - HDC 09 A - 90 Interfaz y diámetro de husillo Shank size Diámetro Interior máx. Max. collet I.D. Longitud de Proyección Projection length (L)
			Ejemplo para Ordenar - Ordering Example HSK63A - HDC 09 A - 90 - H Interfaz y diámetro de husillo Shank size Diámetro Interior máx. Max. collet I.D. Longitud de Proyección Projection length (L) Barreno de Cambio Manual Manual clamping hole

SDM

Drill Holder With Easy Tool Length Adjustment

- La longitud de proyección de la herramienta de corte se puede ajustar simplemente girando la circunferencia del portaherramienta.
- Projection length of the cutting tool can be adjusted by simply turning circumference of the holder.

Tipo1
Type1

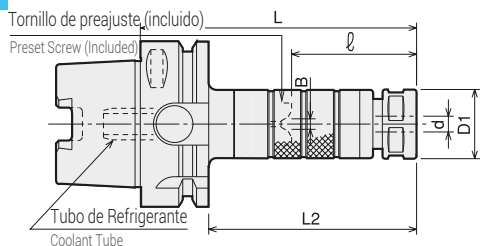

Tipo2
Type2

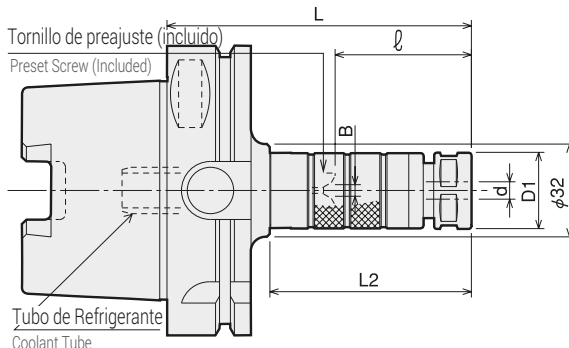

Tipo3
Type3

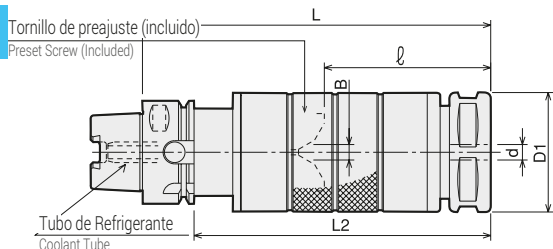

- Tubo de refrigerante incluido.
- Coolant tube is included.

Unidad : Métrico
Unit : Metric

Código Code	Modelo Model	Tipo Type	d	L	ℓ	L2	B	D1	Tuerca ciega Nut	Boquilla Collet	Llave Inglesa Spanner
5710 13007075	HSK40A -SDM07 -75	1	0.5 ~ 7.0	75	29 ~ 39	55	0 ~ 4	23	HDP-07A	FDC-07	S-0
5710 13007090	-90	1	0.5 ~ 7.0	90	29 ~ 54	70	0 ~ 4	23	HDP-07A		
5710 13007105	-105	1	0.5 ~ 7.0	105	29 ~ 54	85	0 ~ 4	23	HDP-07A		
5710 13007120	-120	1	0.5 ~ 7.0	120	29 ~ 54	100	0 ~ 4	23	HDP-07A		
5710 13009075	HSK40A -SDM09 -75	1	2.5 ~ 9.0	75	28 ~ 38	55	0 ~ 4	26	HDP-09	FDC-09	S-1L
5710 13009090	-90	1	2.5 ~ 9.0	90	28 ~ 53	70	0 ~ 4	26	HDP-09		
5710 13009105	-105	1	2.5 ~ 9.0	105	28 ~ 53	85	0 ~ 4	26	HDP-09		
5710 13009120	-120	1	2.5 ~ 9.0	120	28 ~ 53	100	0 ~ 4	26	HDP-09		
5710 13012090	HSK40A -SDM12 -90	1	2.5 ~ 12.0	90	34 ~ 44	70	0 ~ 5	32	HDP-12	FDC-12	S-3L
5710 13012105	-105	1	2.5 ~ 12.0	105	34 ~ 59	85	0 ~ 5	32	HDP-12		
5710 13012120	-120	1	2.5 ~ 12.0	120	34 ~ 59	100	0 ~ 5	32	HDP-12		
5710 13012135	-135	1	2.5 ~ 12.0	135	34 ~ 59	115	0 ~ 5	32	HDP-12		
5710 13012150	-150	1	2.5 ~ 12.0	150	34 ~ 59	130	0 ~ 5	32	HDP-12		
5710 13016120	HSK40A -SDM16 -120	3	3.5 ~ 16.0	120	40 ~ 50	100	0 ~ 6	36	HDP-16	FDC-16	S-4L
5710 13016135	-135	3	3.5 ~ 16.0	135	40 ~ 65	115	0 ~ 6	36	HDP-16		
5710 13016150	-150	3	3.5 ~ 16.0	150	40 ~ 65	130	0 ~ 6	36	HDP-16		
5710 13022120	HSK40A -SDM22 -120	3	3.5 ~ 22.0	120	48 ~ 58	100	0 ~ 8	46	HDP-22	FDC-22	S-5L
5710 13022135	-135	3	3.5 ~ 22.0	135	48 ~ 73	115	0 ~ 8	46	HDP-22		
5710 13022150	-150	3	3.5 ~ 22.0	150	48 ~ 73	130	0 ~ 8	46	HDP-22		
5710 14007090	HSK50A -SDM07 -90	1	0.5 ~ 7.0	90	29 ~ 39	64	0 ~ 4	23	HDP-07A	FDC-07	S-0
5710 14007105	-105	1	0.5 ~ 7.0	105	29 ~ 54	79	0 ~ 4	23	HDP-07A		
5710 14007120	-120	1	0.5 ~ 7.0	120	29 ~ 54	94	0 ~ 4	23	HDP-07A		
5710 14009090	HSK50A -SDM09 -90	1	2.5 ~ 9.0	90	28 ~ 38	64	0 ~ 4	26	HDP-09	FDC-09	S-1L
5710 14009105	-105	1	2.5 ~ 9.0	105	28 ~ 53	79	0 ~ 4	26	HDP-09		
5710 14009120	-120	1	2.5 ~ 9.0	120	28 ~ 53	94	0 ~ 4	26	HDP-09		
5710 14012090	HSK50A -SDM12 -90	1	2.5 ~ 12.0	90	34 ~ 44	64	0 ~ 5	32	HDP-12		
5710 14012105	-105	1	2.5 ~ 12.0	105	34 ~ 59	79	0 ~ 5	32	HDP-12	FDC-12	S-3L
5710 14012120	-120	1	2.5 ~ 12.0	120	34 ~ 59	94	0 ~ 5	32	HDP-12		
5710 14012135	-135	1	2.5 ~ 12.0	135	34 ~ 59	109	0 ~ 5	32	HDP-12		
5710 14012150	-150	1	2.5 ~ 12.0	150	34 ~ 59	124	0 ~ 5	32	HDP-12		
5710 14016105	HSK50A -SDM16 -105	1	3.5 ~ 16.0	105	40 ~ 50	79	0 ~ 6	36	HDP-16	FDC-16	S-4L
5710 14016120	-120	1	3.5 ~ 16.0	120	40 ~ 65	94	0 ~ 6	36	HDP-16		
5710 14016135	-135	1	3.5 ~ 16.0	135	40 ~ 65	109	0 ~ 6	36	HDP-16		
5710 14016150	-150	1	3.5 ~ 16.0	150	40 ~ 65	124	0 ~ 6	36	HDP-16		
5710 14022135	HSK50A -SDM22 -135	3	3.5 ~ 22.0	135	48 ~ 58	109	0 ~ 8	46	HDP-22	FDC-22	S-5L
5710 14022150	-150	3	3.5 ~ 22.0	150	48 ~ 73	124	0 ~ 8	46	HDP-22		

Código Code	Modelo Model	Tipo Type	d	L	ℓ	L2	B	D1	Tuerca ciega Nut	Boquilla Collet	Llave Inglesa Spanner
5710 75007090	HSK63A -SDM07 -90-H	1	0.5 ~ 7.0	90	29 ~ 39	64	0 ~ 4	23	HDP-07A	FDC-07	S-0
5710 75007105	-105-H	1	0.5 ~ 7.0	105	29 ~ 54	79	0 ~ 4	23	HDP-07A		
5710 75007120	-120-H	1	0.5 ~ 7.0	120	29 ~ 54	94	0 ~ 4	23	HDP-07A		
5710 75007135	-135-H	1	0.5 ~ 7.0	135	29 ~ 54	109	0 ~ 4	23	HDP-07A		
5710 75007150	-150-H	1	0.5 ~ 7.0	150	29 ~ 54	124	0 ~ 4	23	HDP-07A		
5710 75009090	HSK63A -SDM09 -90-H	1	2.5 ~ 9.0	90	28 ~ 38	64	0 ~ 4	26	HDP-09	FDC-09	S-1L
5710 75009105	-105-H	1	2.5 ~ 9.0	105	28 ~ 53	79	0 ~ 4	26	HDP-09		
5710 75009120	-120-H	1	2.5 ~ 9.0	120	28 ~ 53	94	0 ~ 4	26	HDP-09		
5710 75009135	-135-H	1	2.5 ~ 9.0	135	28 ~ 53	109	0 ~ 4	26	HDP-09		
5710 75009150	-150-H	1	2.5 ~ 9.0	150	28 ~ 53	124	0 ~ 4	26	HDP-09		
5710 75009180	-180-H	1	2.5 ~ 9.0	180	28 ~ 53	154	0 ~ 4	26	HDP-09		
5710 75012090	HSK63A -SDM12 -90-H	1	2.5 ~ 12.0	90	34 ~ 44	64	0 ~ 5	32	HDP-12	FDC-12	S-3L
5710 75012105	-105-H	1	2.5 ~ 12.0	105	34 ~ 59	79	0 ~ 5	32	HDP-12		
5710 75012120	-120-H	1	2.5 ~ 12.0	120	34 ~ 59	94	0 ~ 5	32	HDP-12		
5710 75012135	-135-H	1	2.5 ~ 12.0	135	34 ~ 59	109	0 ~ 5	32	HDP-12		
5710 75012150	-150-H	1	2.5 ~ 12.0	150	34 ~ 59	124	0 ~ 5	32	HDP-12		
5710 75012180	-180-H	1	2.5 ~ 12.0	180	34 ~ 59	154	0 ~ 5	32	HDP-12		
5710 75016105	HSK63A -SDM16 -105-H	1	3.5 ~ 16.0	105	40 ~ 50	79	0 ~ 6	36	HDP-16	FDC-16	S-4L
5710 75016120	-120-H	1	3.5 ~ 16.0	120	40 ~ 65	94	0 ~ 6	36	HDP-16		
5710 75016135	-135-H	1	3.5 ~ 16.0	135	40 ~ 65	109	0 ~ 6	36	HDP-16		
5710 75016150	-150-H	1	3.5 ~ 16.0	150	40 ~ 65	124	0 ~ 6	36	HDP-16		
5710 75016180	-180-H	1	3.5 ~ 16.0	180	40 ~ 65	154	0 ~ 6	36	HDP-16		
5710 75022120	HSK63A -SDM22 -120-H	1	3.5 ~ 22.0	120	48 ~ 58	94	0 ~ 8	46	HDP-22	FDC-22	S-5L
5710 75022135	-135-H	1	3.5 ~ 22.0	135	48 ~ 73	109	0 ~ 8	46	HDP-22		
5710 75022150	-150-H	1	3.5 ~ 22.0	150	48 ~ 73	124	0 ~ 8	46	HDP-22		
5710 75022180	-180-H	1	3.5 ~ 22.0	180	48 ~ 73	154	0 ~ 8	46	HDP-22		
5710 77007090	HSK100A -SDM07 -90-H	2	0.5 ~ 7.0	90	29 ~ 39	55	0 ~ 4	23	HDP-07A		
5710 77007105	-105-H	2	0.5 ~ 7.0	105	29 ~ 54	70	0 ~ 4	23	HDP-07A		
5710 77007120	-120-H	2	0.5 ~ 7.0	120	29 ~ 54	81	0 ~ 4	23	HDP-07A		
5710 77007135	-135-H	2	0.5 ~ 7.0	135	29 ~ 54	96	0 ~ 4	23	HDP-07A		
5710 77007150	-150-H	2	0.5 ~ 7.0	150	29 ~ 54	111	0 ~ 4	23	HDP-07A		
5710 77007165	-165-H	2	0.5 ~ 7.0	165	29 ~ 54	126	0 ~ 4	23	HDP-07A		
5710 77009090	HSK100A -SDM09 -90-H	2	2.5 ~ 9.0	90	28 ~ 38	55	0 ~ 4	26	HDP-09	FDC-09	S-1L
5710 77009105	-105-H	2	2.5 ~ 9.0	105	28 ~ 53	70	0 ~ 4	26	HDP-09		
5710 77009120	-120-H	2	2.5 ~ 9.0	120	28 ~ 53	81	0 ~ 4	26	HDP-09		
5710 77009135	-135-H	2	2.5 ~ 9.0	135	28 ~ 53	96	0 ~ 4	26	HDP-09		
5710 77009150	-150-H	2	2.5 ~ 9.0	150	28 ~ 53	111	0 ~ 4	26	HDP-09		
5710 77009180	-180-H	2	2.5 ~ 9.0	180	28 ~ 53	141	0 ~ 4	26	HDP-09		
5710 77012105	HSK100A -SDM12 -105-H	1	2.5 ~ 12.0	105	34 ~ 44	76	0 ~ 5	32	HDP-12	FDC-12	S-3L
5710 77012120	-120-H	1	2.5 ~ 12.0	120	34 ~ 59	91	0 ~ 5	32	HDP-12		
5710 77012135	-135-H	1	2.5 ~ 12.0	135	34 ~ 59	106	0 ~ 5	32	HDP-12		
5710 77012150	-150-H	1	2.5 ~ 12.0	150	34 ~ 59	121	0 ~ 5	32	HDP-12		
5710 77012180	-180-H	1	2.5 ~ 12.0	180	34 ~ 59	151	0 ~ 5	32	HDP-12		
5710 77016105	HSK100A -SDM16 -105-H	1	3.5 ~ 16.0	105	40 ~ 50	76	0 ~ 6	36	HDP-16	FDC-16	S-4L
5710 77016120	-120-H	1	3.5 ~ 16.0	120	40 ~ 65	91	0 ~ 6	36	HDP-16		
5710 77016135	-135-H	1	3.5 ~ 16.0	135	40 ~ 65	106	0 ~ 6	36	HDP-16		
5710 77016150	-150-H	1	3.5 ~ 16.0	150	40 ~ 65	121	0 ~ 6	36	HDP-16		
5710 77016180	-180-H	1	3.5 ~ 16.0	180	40 ~ 65	151	0 ~ 6	36	HDP-16		
5710 77022120	HSK100A -SDM22 -120-H	1	3.5 ~ 22.0	120	48 ~ 58	91	0 ~ 8	46	HDP-22	FDC-22	S-5L
5710 77022135	-135-H	1	3.5 ~ 22.0	135	48 ~ 73	106	0 ~ 8	46	HDP-22		
5710 77022150	-150-H	1	3.5 ~ 22.0	150	48 ~ 73	121	0 ~ 8	46	HDP-22		
5710 77022180	-180-H	1	3.5 ~ 22.0	180	48 ~ 73	151	0 ~ 8	46	HDP-22		
5710 77022210	-210-H	1	3.5 ~ 22.0	210	48 ~ 73	181	0 ~ 8	46	HDP-22		

1. La boquilla y la llave inglesa se venden por separado.
2. ℓ es la dimensión entre el cabezal de la tuerca y el extremo superior del tornillo de preajuste.
3. Consulte la pág. 521 para conocer el Torque estándar de apriete.

1. Collet and spanner are sold separately.
2. ℓ is the dimension between the cap end and the preset screw top end.
3. See P.521 for standard Tightening Torque.

Boquilla Collet Pág. 090-093	Llave Inglesa Spanner Pág. 099
	

Ejemplo para Ordenar - Ordering Example

HSK50A - SDM 12 - 90 - H

Interfaz y diámetro de husillo Shank size	Diámetro Interior máx. Max. collet I.D.	Longitud de Proyección Projection length (L)	Barreno de Cambio Manual Manual clamping hole
--	--	---	--

Ejemplo para Ordenar - Ordering Example

HSK50A - SDM 12 - 90

Interfaz y diámetro de husillo Shank size	Diámetro Interior máx. Max. collet I.D.	Longitud de Proyección Projection length (L)
--	--	---

GDC-A

High-Precision Collet Holder (High-Balanced Type)

- Adecuado para barrenado con rotación a alta velocidad, rima y acabado en fresa.
- Suitable for high speed rotation drilling, reaming, and finish endmilling.

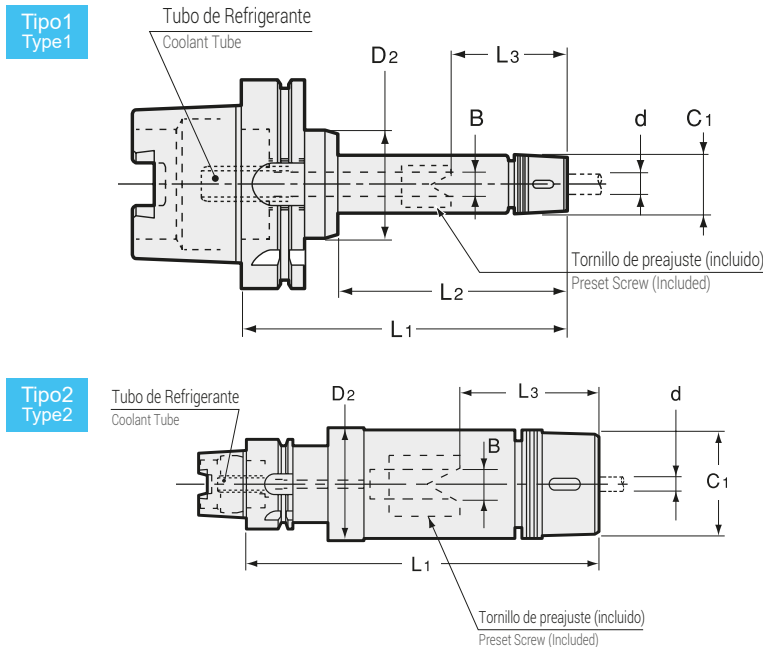

- Tubo de refrigerante incluido.
- Coolant tube is included.

Unidad : Métrico
Unit : Metric

Código Code	Modelo Model	Tipo Type	d	L1	L2	B	L3	D2	C1	Tuerca ciega Nut	kg	Boquilla Collet	Llave Inglesa Spanner
5380 13007075	HSK40A -GDC07A -75	1	0.5 ~ 7.0	75	40	0 ~ 4	22 ~ 29	34	23	HDP-07A	0.4	FDC-07AA	S-0
5380 13007090	-90	1	0.5 ~ 7.0	90	55	0 ~ 4	22 ~ 44	34	23	HDP-07A			
5380 13007120	-120	1	0.5 ~ 7.0	120	85	0 ~ 4	22 ~ 45	34	23	HDP-07A			
5380 13009075	HSK40A -GDC09A -75	1	2.5 ~ 9.0	75	40	0 ~ 4	27	34	29	GDP-09	0.5	FDC-09AA	S-0
5380 13009090	-90	1	2.5 ~ 9.0	90	55	0 ~ 4	27 ~ 40	34	29	GDP-09			
5380 13009120	-120	1	2.5 ~ 9.0	120	85	0 ~ 4	27 ~ 57	34	29	GDP-09			
5380 13012090	HSK40A -GDC12A -90	2	2.5 ~ 12.0	90	-	-	41	39	34	GDP-12	0.6	FDC-12AA	FK-0034
5380 13012120	-120	2	2.5 ~ 12.0	120	-	0 ~ 5	33 ~ 51	39	34	GDP-12	0.8		
5380 13012150	-150	2	2.5 ~ 12.0	150	-	0 ~ 5	33 ~ 78	39	34	GDP-12			
5380 13016090	HSK40A -GDC16A -90	2	3.5 ~ 16.0	90	-	-	40	42	38	GDP-16	0.7	FDC-16AA	FK-0034
5380 13016120	-120	2	3.5 ~ 16.0	120	-	0 ~ 6	38 ~ 46	42	38	GDP-16			
5380 13016150	-150	2	3.5 ~ 16.0	150	-	0 ~ 6	38 ~ 74	42	38	GDP-16	1.1		
5380 13022120	HSK40A -GDC22A -120	2	3.5 ~ 22.0	120	-	-	68	49	49	GDP-22		FDC-22AA	FK-0045
5380 13022150	-150	2	3.5 ~ 22.0	150	-	0 ~ 8	47 ~ 75	49	49	GDP-22			
5380 14007075	HSK50A -GDC07A -75	1	0.5 ~ 7.0	75	34	0 ~ 4	22 ~ 24	42	23	HDP-07A		FDC-07AA	S-0
5380 14007090	-90	1	0.5 ~ 7.0	90	49	0 ~ 4	22 ~ 39	42	23	HDP-07A			
5380 14007120	-120	1	0.5 ~ 7.0	120	79	0 ~ 4	22 ~ 45	42	23	HDP-07A	0.8		
5380 14009075	HSK50A -GDC09A -75	1	2.5 ~ 9.0	75	34	0 ~ 4	27 ~ 35	42	29	GDP-09	0.7	FDC-09AA	S-0
5380 14009090	-90	1	2.5 ~ 9.0	90	49	0 ~ 4	27 ~ 39	42	29	GDP-09	0.7		
5380 14009120	-120	1	2.5 ~ 9.0	120	79	0 ~ 4	27 ~ 57	42	29	GDP-09	0.9		
5380 14012090	HSK50A -GDC12A -90	1	2.5 ~ 12.0	90	49	-	52	42	34	GDP-12	0.8	FDC-12AA	FK-0034
5380 14012120	-120	1	2.5 ~ 12.0	120	79	0 ~ 5	33 ~ 60	42	34	GDP-12	1.0		
5380 14012150	-150	1	2.5 ~ 12.0	150	109	0 ~ 5	33 ~ 78	42	34	GDP-12	1.2		
5380 14016090	HSK50A -GDC16A -90	1	3.5 ~ 16.0	90	49	-	52	42	38	GDP-16	0.8	FDC-16AA	FK-0034
5380 14016120	-120	1	3.5 ~ 16.0	120	79	0 ~ 6	38 ~ 58	42	38	GDP-16	1.0		
5380 14016150	-150	1	3.5 ~ 16.0	150	109	0 ~ 6	38 ~ 86	42	38	GDP-16	1.2		
5380 14022120	HSK50A -GDC22A -120	2	3.5 ~ 22.0	120	-	-	62	49	49	GDP-22	1.3	FDC-22AA	FK-0045
5380 14022150	-150	2	3.5 ~ 22.0	150	-	0 ~ 8	47 ~ 70	49	49	GDP-22	1.6		

Unidad : Métrico
Unit : Metric

Código Code	Modelo Model	Tipo Type	d	L1	L2	B	L3	D2	C1	Tuerca ciega Nut	kg	Boquilla Collet	Llave Inglesa Spanner
5380 75007075	HSK63A -GDC07A -75-H	1	0.5 ~ 7.0	75	34	0 ~ 4	22 ~ 35	52	23	HDP-07A	1.0	FDC-07AA	S-0
5380 75007090	-90-H	1	0.5 ~ 7.0	90	49	0 ~ 4	22 ~ 45	52	23	HDP-07A	1.0		
5380 75007120	-120-H	1	0.5 ~ 7.0	120	79	0 ~ 4	22 ~ 45	52	23	HDP-07A	1.1		
5380 75009075	HSK63A -GDC09A -75-H	1	2.5 ~ 9.0	75	34	0 ~ 4	27 ~ 34	52	29	GDP-09	1.0	FDC-09AA	S-0
5380 75009090	-90-H	1	2.5 ~ 9.0	90	49	0 ~ 4	27 ~ 42	52	29	GDP-09	1.1		
5380 75009120	-120-H	1	2.5 ~ 9.0	120	79	0 ~ 4	27 ~ 57	52	29	GDP-09	1.3		
5380 75012090	HSK63A -GDC12A -90-H	1	2.5 ~ 12.0	90	49	—	52	52	34	GDP-12	1.1	FDC-12AA	FK-0034
5380 75012120	-120-H	1	2.5 ~ 12.0	120	79	0 ~ 5	33 ~ 60	52	34	GDP-12	1.3		
5380 75012150	-150-H	1	2.5 ~ 12.0	150	109	0 ~ 5	33 ~ 78	52	34	GDP-12	1.5		
5380 75016090	HSK63A -GDC16A -90-H	1	3.5 ~ 16.0	90	49	—	60	52	38	GDP-16	1.2	FDC-16AA	FK-0034
5380 75016120	-120-H	1	3.5 ~ 16.0	120	79	0 ~ 6	38 ~ 59	52	38	GDP-16	1.4		
5380 75016150	-150-H	1	3.5 ~ 16.0	150	109	0 ~ 6	38 ~ 82	52	38	GDP-16	1.6		
5380 75022090	HSK63A -GDC22A -90-H	1	3.5 ~ 22.0	90	49	—	63	52	49	GDP-22	1.2	FDC-22AA	FK-0045
5380 75022120	-120-H	1	3.5 ~ 22.0	120	79	0 ~ 8	47 ~ 56	52	49	GDP-22	1.6		
5380 75022150	-150-H	1	3.5 ~ 22.0	150	109	0 ~ 8	47 ~ 86	52	49	GDP-22	1.8		
5380 77007075	HSK100A -GDC07A -75-H	1	0.5 ~ 7.0	75	31	0 ~ 4	22 ~ 27	84	23	HDP-07A	2.6	FDC-07AA	S-0
5380 77007090	-90-H	1	0.5 ~ 7.0	90	46	0 ~ 4	22 ~ 45	84	23	HDP-07A	2.7		
5380 77007120	-120-H	1	0.5 ~ 7.0	120	76	0 ~ 4	22 ~ 45	84	23	HDP-07A	2.9		
5380 77009075	HSK100A -GDC09A -75-H	1	2.5 ~ 9.0	75	31	0 ~ 4	27 ~ 28	84	29	GDP-09	2.6	FDC-09AA	S-0
5380 77009090	-90-H	1	2.5 ~ 9.0	90	46	0 ~ 4	27 ~ 43	84	29	GDP-09	2.8		
5380 77009120	-120-H	1	2.5 ~ 9.0	120	76	0 ~ 4	27 ~ 57	84	29	GDP-09	2.9		
5380 77012090	HSK100A -GDC12A -90-H	1	2.5 ~ 12.0	90	46	—	52	84	34	GDP-12	2.8	FDC-12AA	FK-0034
5380 77012120	-120-H	1	2.5 ~ 12.0	120	76	0 ~ 5	33 ~ 60	84	34	GDP-12	3.0		
5380 77012150	-150-H	1	2.5 ~ 12.0	150	106	0 ~ 5	33 ~ 78	84	34	GDP-12	3.2		
5380 77016090	HSK100A -GDC16A -90-H	1	3.5 ~ 16.0	90	46	0 ~ 6	38 ~ 41	84	38	GDP-16	2.9	FDC-16AA	FK-0034
5380 77016120	-120-H	1	3.5 ~ 16.0	120	76	0 ~ 6	38 ~ 62	84	38	GDP-16	3.1		
5380 77016150	-150-H	1	3.5 ~ 16.0	150	106	0 ~ 6	38 ~ 82	84	38	GDP-16	3.3		
5380 77022090	HSK100A -GDC22A -90-H	1	3.5 ~ 22.0	90	46	—	57	84	49	GDP-22	2.9	FDC-22AA	FK-0045
5380 77022120	-120-H	1	3.5 ~ 22.0	120	76	0 ~ 8	47 ~ 57	84	49	GDP-22	3.2		
5380 77022150	-150-H	1	3.5 ~ 22.0	150	106	0 ~ 8	47 ~ 83	84	49	GDP-22	3.5		

1. La boquilla, el tornillo de pre-ajuste y la llave inglesa se venden por separado.
2. Siempre use boquillas de categoría "AA".
3. Consulte la pág. 096 para conocer la longitud mínima para insertar herramientas en caso de usar nuestras boquillas refrigerantes (OH, C o MS).
4. L2 indica la dimensión cuando se use con un tornillo de preajuste.
5. Consulte la pág. 521 para conocer el Torque recomendado para nuestros productos.

1. Collet, preset screw and spanner are sold separately.
2. Always use "AA" class collet.
3. Refer to pág. 096 for minimum tool insertion length in case of using our coolant collets (OH, C or MS).
4. L3 indicates dimension when using with a preset screw.
5. See P.521 for standard Tightening Torque.

Boquilla Collet Pág. 090-093 	Llave Inglesa Spanner Pág. 099 	Tornillo de preajuste Preset screw Pág. 098 
--	--	---

Ejemplo para Ordenar - Ordering Example

HSK50A - GDC 07 A - 90

Interfaz y diámetro de husillo Shank size	Máx. Diámetro Interno de boquilla Max. collet I.D.	Longitud de Proyección Projection length (L)
--	---	---

Ejemplo para Ordenar - Ordering Example

HSK50A - GDC 107 A - 90 - H

Interfaz y diámetro de husillo Shank size	Máx. Diámetro Interno de boquilla Max. collet I.D.	Longitud de Proyección Projection length (L)	Barreno de Cambio Manual Manual clamping hole
--	---	---	--

Collet Holder For Small Diameters

- Para barrenado en espacios angostos.
- For drilling in tight space.

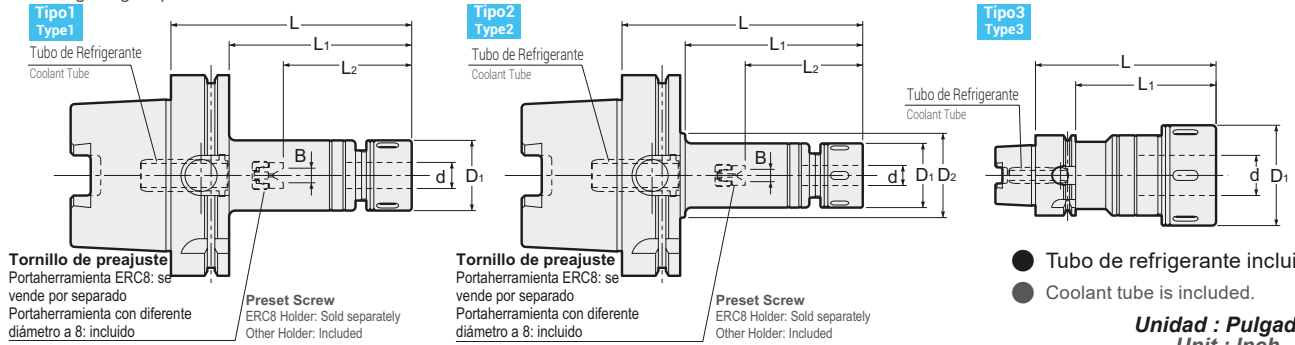

Unidad : Pulgadas
Unit : Inch

Código Code	Modelo Model	Tipo Type	d	L	L1	B	L2	D1	D2	kg	Tornillo de preajuste Preset Screw	Tuerca ciega Nut	Boquilla Collet	Llave Inglesa Spanner
5370 00308060	HSK40A -ERC8 -60	1	0.020 ~ 0.197	2.362	1.575	— (0~0.094)	1.299 (0.748~1.220)	0.472	—	0.2	—	ERP-8	ER8	S-8E
5370 00308075	-75	1	0.020 ~ 0.197	2.953	2.165	— (0~0.094)	1.299 (0.748~1.220)	0.472	—	0.2	—	ERP-8	ER8	S-8E
5370 00308090	-90	1	0.020 ~ 0.197	3.543	2.756	— (0~0.094)	1.299 (0.748~1.220)	0.472	—	0.3	—	ERP-8	ER8	S-8E
5370 00310060	HSK40A -ERC11S -60	1	0.020 ~ 0.276	2.362	1.575	—	1.417	0.630	—	0.2	—	ERP-11S	ER11	S-11E
5370 00310075	-75	1	0.020 ~ 0.276	2.953	2.165	0.0 ~ 0.157	0.866 ~ 1.378	0.630	—	0.3	HDC07A-ES11	ERP-11S	ER11	S-11E
5370 00310090	-90	1	0.020 ~ 0.276	3.543	2.756	0.0 ~ 0.157	0.866 ~ 1.654	0.630	—	0.3	HDC07A-ES11	HDP-07A	ER11	S-0
5370 00311075	HSK40A -ERC11 -75	1	0.020 ~ 0.276	2.953	2.165	0.0 ~ 0.157	0.866 ~ 1.378	0.906	—	0.3	—	HDP-07A	ER11	S-0
5370 00311090	-90	1	0.020 ~ 0.276	3.543	2.756	0.0 ~ 0.157	0.866 ~ 1.811	0.906	—	—	—	HDP-07A	ER11	S-0
5370 00311120	-120	1	0.020 ~ 0.276	4.724	3.937	0.0 ~ 0.157	0.866 ~ 1.811	0.906	—	—	—	HDP-07A	ER11	S-0
5370 00316075	HSK40A -ERC16 -75	1	0.020 ~ 0.394	2.953	2.165	—	1.811	1.260	—	—	—	ERP-16	ER16	FK0030
5370 00316090	-90	1	0.020 ~ 0.394	3.543	2.756	0.0 ~ 0.197	1.299 ~ 1.772	1.260	—	—	ES16	ERP-16	ER16	FK0030
5370 00316120	-120	1	0.020 ~ 0.394	4.724	3.937	0.0 ~ 0.197	1.299 ~ 2.126	1.260	—	—	ES16	ERP-16	ER16	FK0030
5370 00320090	HSK40A -ERC20 -90	1	0.020 ~ 0.512	3.543	2.756	—	2.362	1.378	—	—	—	ERP-20	ER20	FK0034
5370 00320120	-120	1	0.020 ~ 0.512	4.724	3.937	0.0 ~ 0.236	1.496 ~ 2.638	1.378	—	—	HDS12A-ES20	ERP-20	ER20	FK0034
5370 00325090	HSK40A -ERC25 -90	1	0.020 ~ 0.630	3.543	2.756	—	2.323	1.654	—	—	—	ERP-25	ER25	HS-1-16
5370 00325120	-120	1	0.020 ~ 0.630	4.724	3.937	0.0 ~ 0.315	1.693 ~ 2.795	1.654	—	—	HDS16A-ES25	ERP-25	ER25	HS-1-16
5370 00332090	HSK40A -ERC32 -90	3	0.098 ~ 0.787	3.543	2.756	—	2.441	1.969	—	—	—	ERP-32	ER32	HS-2-20
5370 75008075	HSK63A -ERC8 -75-H	1	0.020 ~ 0.197	2.953	1.929	— (0~0.094)	1.299 (0.748~1.220)	0.472	—	0.7	—	ERP-8	ER8	S-8E
5370 75008105	-105-H	1	0.020 ~ 0.197	4.134	3.110	— (0~0.094)	1.299 (0.748~1.220)	0.472	—	0.7	—	ERP-8	ER8	S-8E
5370 75010075	HSK63A -ERC11S -75-H	1	0.020 ~ 0.276	2.953	1.929	0.0 ~ 0.157	0.866 ~ 1.260	0.630	—	0.7	—	ERP-11S	ER11	S-11E
5370 75010105	-105-H	1	0.020 ~ 0.276	4.134	3.110	0.0 ~ 0.157	0.866 ~ 1.654	0.630	—	0.8	HDC07A-ES11	ERP-11S	ER11	S-11E
5370 75011075	HSK63A -ERC11 -75-H	1	0.020 ~ 0.276	2.953	1.929	0.0 ~ 0.157	0.866 ~ 1.260	0.906	—	—	HDC07A-ES11	HDP-07A	ER11	S-0
5370 75011090	-90-H	1	0.020 ~ 0.276	3.543	2.520	0.0 ~ 0.157	0.866 ~ 1.654	0.906	—	0.8	—	HDP-07A	ER11	S-0
5370 75011120	-120-H	1	0.020 ~ 0.276	4.724	3.701	0.0 ~ 0.157	0.866 ~ 1.654	0.906	—	—	—	HDP-07A	ER11	S-0
5370 75016075	HSK63A -ERC16 -75-H	1	0.020 ~ 0.394	2.953	1.929	—	1.811	1.260	—	0.9	—	ERP-16	ER16	FK0030
5370 75016090	-90-H	1	0.020 ~ 0.394	3.543	2.520	0.0 ~ 0.197	1.299 ~ 1.575	1.260	—	—	ES16	ERP-16	ER16	FK0030
5370 75016105	-105-H	1	0.020 ~ 0.394	4.134	3.110	0.0 ~ 0.197	1.299 ~ 2.126	1.260	—	1.1	ES16	ERP-16	ER16	FK0030
5370 75016120	-120-H	1	0.020 ~ 0.394	4.724	3.701	0.0 ~ 0.197	1.299 ~ 2.126	1.260	—	1.2	ES16	ERP-16	ER16	FK0030
5370 75016165	-165-H	1	0.020 ~ 0.394	6.496	5.472	0.0 ~ 0.197	1.299 ~ 2.126	1.260	—	—	ES16	ERP-16	ER16	FK0030

Código Code	Modelo Model	Tipo Type	d	L	L1	B	L2	D1	D2	kg	Tornillo de preajuste Preset Screw	Tuerca ciega Nut	Boquilla Collet	Llave Inglesa Spanner
5370 75020090	HSK63A -ERC20 -90-H	1	0.020 ~ 0.512	3.543	2.520	—	2.165	1.378	—	—	—	—	—	—
5370 75020120	-120-H	1	0.020 ~ 0.512	4.724	3.701	0.0 ~ 0.236	1.496 ~ 2.559	1.378	—	—	HDS12A-ES20	ERP-20	ER20	FK0034
5370 75020150	-150-H	1	0.020 ~ 0.512	5.906	4.882	0.0 ~ 0.236	1.496 ~ 2.638	1.378	—	—	—	—	—	—
5370 75025075	HSK63A -ERC25 -75-H	1	0.020 ~ 0.630	2.953	1.929	—	1.732	1.654	—	—	—	—	—	—
5370 75025090	-90-H	1	0.020 ~ 0.630	3.543	2.520	—	2.323	1.654	—	—	—	ERP-25	ER25	HS-1-16
5370 75025120	-120-H	1	0.020 ~ 0.630	4.724	3.701	0.0 ~ 0.315	1.693 ~ 2.598	1.654	—	1.4	HDS16A-ES25	—	—	—
5370 75025150	-150-H	1	0.020 ~ 0.630	5.906	4.882	0.0 ~ 0.315	1.693 ~ 3.150	1.654	—	—	—	—	—	—
5370 75032090	HSK63A -ERC32 -90-H	1	0.079 ~ 0.787	3.543	2.520	—	2.244	1.969	—	—	—	—	—	—
5370 75032105	-105-H	1	0.079 ~ 0.787	4.134	3.110	—	2.638	1.969	—	1.5	—	ERP-32	ER32	HS-2-20
5370 75032120	-120-H	1	0.079 ~ 0.787	4.724	3.701	0.0 ~ 0.394	1.969 ~ 2.323	1.969	—	1.7	HDS22A-ES32	—	—	—
5370 75032150	-150-H	1	0.079 ~ 0.787	5.906	4.882	0.0 ~ 0.394	1.969 ~ 3.504	1.969	—	—	—	—	—	—
5370 75040120	HSK63A -ERC40 -120-H	1	0.118 ~ 1.024	4.724	3.701	—	3.150	2.480	—	—	—	ERP-40	ER40	HS-2.5-25
5370 77011075	HSK100A -ERC11 -75-H	2	0.020 ~ 0.276	2.953	1.417	—	1.496	0.906	1.260	—	—	—	—	—
5370 77011090	-90-H	2	0.020 ~ 0.276	3.543	2.008	0.0 ~ 0.157	0.866 ~ 1.654	0.906	1.260	—	HDS07A-ES11	HDP-07A	ER11	S-0
5370 77011120	-120-H	2	0.020 ~ 0.276	4.724	3.189	0.0 ~ 0.157	0.866 ~ 1.654	0.906	1.260	—	—	—	—	—
5370 77016075	HSK100A -ERC16 -75-H	2	0.020 ~ 0.394	2.953	1.693	—	1.654	1.260	1.654	—	—	—	—	—
5370 77016090	-90-H	2	0.020 ~ 0.394	3.543	2.283	0.0 ~ 0.197	1.299 ~ 1.457	1.260	1.654	—	ES16	ERP-16	ER16	FK0030
5370 77016120	-120-H	2	0.020 ~ 0.394	4.724	3.465	0.0 ~ 0.197	1.299 ~ 2.126	1.260	1.654	—	—	—	—	—
5370 77020090	HSK100A -ERC20 -90-H	1	0.020 ~ 0.512	3.543	2.402	—	2.087	1.378	—	—	—	—	—	—
5370 77020120	-120-H	1	0.020 ~ 0.512	4.724	3.583	0.0 ~ 0.236	1.496 ~ 2.323	1.378	—	—	HDS12A-ES20	ERP-20	ER20	FK0034
5370 77020150	-150-H	1	0.020 ~ 0.512	5.906	4.764	0.0 ~ 0.236	1.496 ~ 2.638	1.378	—	—	—	—	—	—
5370 77025090	HSK100A -ERC25 -90-H	1	0.020 ~ 0.630	3.543	2.402	—	2.087	1.654	—	—	—	—	—	—
5370 77025120	-120-H	1	0.020 ~ 0.630	4.724	3.583	0.0 ~ 0.315	1.693 ~ 2.362	1.654	—	—	HDS16A-ES25	ERP-25	ER25	HS-1-16
5370 77025150	-150-H	1	0.020 ~ 0.630	5.906	4.764	0.0 ~ 0.315	1.693 ~ 3.150	1.654	—	—	—	—	—	—
5370 77032090	HSK100A -ERC32 -90-H	1	0.098 ~ 0.787	3.543	2.402	—	2.008	1.969	—	—	—	—	—	—
5370 77032105	-105-H	1	0.098 ~ 0.787	4.134	2.992	—	2.598	1.969	—	2.8	—	ERP-32	ER32	HS-2-20
5370 77032120	-120-H	1	0.098 ~ 0.787	4.724	3.583	0.0 ~ 0.394	1.969 ~ 2.126	1.969	—	—	HDS22A-ES32	—	—	—
5370 77032150	-150-H	1	0.098 ~ 0.787	5.906	4.764	0.0 ~ 0.394	1.969 ~ 3.307	1.969	—	3.4	—	—	—	—
5370 77040120	HSK100A -ERC40 -120-H	1	0.118 ~ 1.024	4.724	3.583	—	2.913	2.480	—	3.5	—	ERP-40	ER40	HS-2.5-25
5370 77050135	HSK100A -ERC50 -135-H	1	0.394 ~ 1.339	5.315	4.173	—	3.307	3.071	—	—	—	ERP-50	ER50	HS-4-42

- La boquilla y la llave inglesa se venden por separado.
- El ES8, un tornillo de preajuste para el ERC8, se vende por separado. El ERC11S incluye un tornillo estándar de preajuste HDS-07A-ES11.
- Las dimensiones "B" y "L2" entre corchetes sirven para usar el tornillo de preajuste ES8.
- Consulte la pág. 096 para conocer la longitud mínima para insertar herramientas en caso de usar nuestras boquillas refrigerantes.
- Consulte la pág. 521 para conocer el Torque recomendado para nuestros productos.

<p>Boquilla Collet</p> <p>Pág. 094-095</p> 	<p>Llave de Torque Spanner</p> <p>Pág. 099</p> 	<p>Tornillo de preajuste Preset screw</p> <p>Pág. 098</p> 
--	--	---

Ejemplo para Ordenar - Ordering Example

HSK63A - ERC 8 - 75

Interfaz y diámetro de husillo Shank size Máx. Diámetro Interno de boquilla Max. collet I.D. Longitud de Proyección Projection length (L)

Ejemplo para Ordenar - Ordering Example

HSK63A - ERC 8 - 75 - H

Interfaz y diámetro de husillo Shank size Máx. Diámetro Interno de boquilla Max. collet I.D. Longitud de Proyección Projection length (L) Barreno de Cambio Manual Manual clamping hole

ERC-T

Collet Holder For Small Diameters (Taper Type)

- Para barrenado en espacios angostos.
- For drilling in tight space.

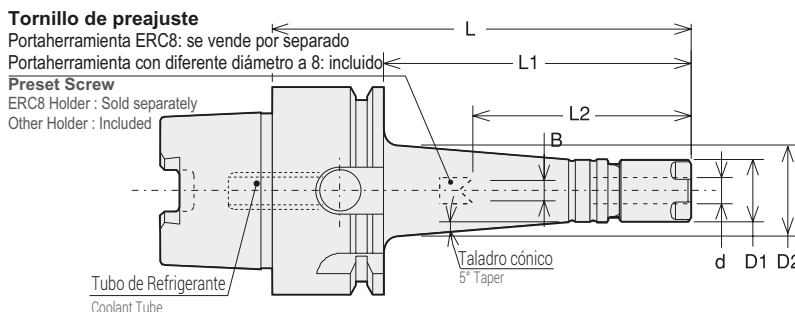

- Tubo de refrigerante incluido.
- Coolant tube is included.

Unidad : Métrico
 Unit : Metric

Código Code	Modelo Model	d	L	L1	B	L2	D1	D2	Tuerca ciega Nut	kg	Boquilla Collet	Llave Inglesa Spanner
5370 01308060	HSK40A -ERC8 -60T	0.5 ~ 5.0	60	40	—	34	12	15	ERP-8	0.3	ER8	S-8E
5370 01308075	-75T	0.5 ~ 5.0	75	55	(0 ~ 2.4)	(19 ~ 31)	12	17.5	ERP-8	0.3		
5370 01308090	-90T	0.5 ~ 5.0	90	70	(0 ~ 2.4)	(19 ~ 31)	12	20.5	ERP-8	0.3		
5370 01308105	-105T	0.5 ~ 5.0	105	85	(0 ~ 2.4)	(19 ~ 31)	12	23	ERP-8	0.4		
5370 01310060	HSK40A -ERC11S -60T	0.5 ~ 7.0	60	40	0 ~ 4	22 ~ 24	16	19	ERP-11S	0.3	FDC-07	S-11E
5370 01310075	-75T	0.5 ~ 7.0	75	55	0 ~ 4	22 ~ 38	16	21.5	ERP-11S	0.4		
5370 01310090	-90T	0.5 ~ 7.0	90	70	0 ~ 4	22 ~ 45	16	24	ERP-11S	0.4		
5370 01310090	-105T	0.5 ~ 7.0	105	85	0 ~ 4	22 ~ 45	16	26.5	ERP-11S	0.4		
5370 01408075	HSK50A -ERC8 -75T	0.5 ~ 5.0	75	49	(0 ~ 2.4)	(19 ~ 30)	12	16.5	ERP-8	0.5	ER8	S-8E
5370 01408090	-90T	0.5 ~ 5.0	90	64	(0 ~ 2.4)	(19 ~ 31)	12	19.5	ERP-8	0.5		
5370 01408105	-105T	0.5 ~ 5.0	105	79	(0 ~ 2.4)	(19 ~ 31)	12	22	ERP-8	0.5		
5370 01410075	HSK50A -ERC11S -75T	0.5 ~ 7.0	75	49	0 ~ 4	22 ~ 32	16	20.5	ERP-11S	0.6	FDC-07	S-11E
5370 01410090	-90T	0.5 ~ 7.0	90	64	0 ~ 4	22 ~ 45	16	23	ERP-11S	0.6		
5370 01410105	-105T	0.5 ~ 7.0	105	79	0 ~ 4	22 ~ 45	16	25.5	ERP-11S	0.7		
5370 75108060	HSK63A -ERC8 -60T-H	0.5 ~ 5.0	60	34	—	34	12	14	ERP-8	0.7	ER8	S-8E
5370 75108075	-75T-H	0.5 ~ 5.0	75	49	(0 ~ 2.4)	(19 ~ 28)	12	16.5	ERP-8	0.8		
5370 75108090	-90T-H	0.5 ~ 5.0	90	64	(0 ~ 2.4)	(19 ~ 31)	12	19.5	ERP-8	0.8		
5370 75108105	-105T-H	0.5 ~ 5.0	105	79	(0 ~ 2.4)	(19 ~ 31)	12	22	ERP-8	0.8		
5370 75108120	-120T-H	0.5 ~ 5.0	120	94	(0 ~ 2.4)	(19 ~ 31)	12	24.5	ERP-8	0.9		
5370 75108135	-135T-H	0.5 ~ 5.0	135	109	(0 ~ 2.4)	(19 ~ 31)	12	27	ERP-8	0.9		
5370 75110060	HSK63A -ERC11S -60T-H	0.5 ~ 7.0	60	34	—	22 ~ 24	16	18	ERP-11S	0.7	FDC-07	S-11E
5370 75110075	-75T-H	0.5 ~ 7.0	75	49	0 ~ 4	22 ~ 38	16	20.5	ERP-11S	0.8		
5370 75110090	-90T-H	0.5 ~ 7.0	90	64	0 ~ 4	22 ~ 45	16	23	ERP-11S	0.8		
5370 75110105	-105T-H	0.5 ~ 7.0	105	79	0 ~ 4	22 ~ 45	16	25.5	ERP-11S	0.9		
5370 75110120	-120T-H	0.5 ~ 7.0	120	94	0 ~ 4	22 ~ 45	16	28.5	ERP-11S	0.9		
5370 75110135	-135T-H	0.5 ~ 7.0	135	109	0 ~ 4	22 ~ 45	16	31	ERP-11S	1.0		

1. La boquilla y la llave inglesa se venden por separado.
2. El ES8, un tornillo de preajuste para el ERC8-T, se vende por separado. El ERC11S-T incluye un tornillo estándar de preajuste HDS-07A-ES11.
3. Las dimensiones "B" y "L2" entre corchetes sirven para usar el tornillo de preajuste ES8.
4. Consulte la pág. 096 para conocer la longitud mínima para insertar herramientas en caso de usar nuestras boquillas refrigerantes.
5. Consulte la pág. 521 para conocer el Torque estándar de apriete.

1. Collet and spanner are sold separately.
2. ES8, a preset screw for ERC8-T, is sold separately. ERC11S-T includes a standard preset screw HDS-07A-ES11.
3. " B " and " L2 " dimensions in brackets are for using ES8 preset screw.
4. Refer to P.096 for minimum tool insertion length in case of using our coolant collets.
5. See P.521 for standard Tightening Torque.



Ejemplo para Ordenar - Ordering Example

HSK40A - ERC 8 - 105 T

Interfaz y
diámetro
de husillo

Shank size

Máx. Diámetro
Interno de
boquilla

Max. collet I.D.

Longitud de
Proyección

Projection
length (L)

Ejemplo para Ordenar - Ordering Example

HSK63A - ERC 8 - 60 T - H

Interfaz y
diámetro
de husillo

Shank size

Máx. Diámetro
Interno de
boquilla

Max. collet I.D.

Longitud de
Proyección

Projection
length (L)

Barreno
de Cambio
Manual

Manual
clamping hole

BT
CAT
AHO
HSK-A/E/F/C
HSK-T
C
UTS
Máquinas Especializadas Specialized Machine
Equipo Relacionado Related Equipment
Taladro de Biselado & de Casquillo Bush & Chamfering Drill

Milling Chuck
Collet Holder
"R" Zero Holder
Hydraulic Chuck
Shrink Fit
Tapping Chuck
Arbors
Function Holder
HSK-E
HSK-F
HSK-C
Dimensions

"R" Zero Holder

- La precisión de excentricidad del borde de corte puede ajustarse hasta casi cero.
- Runout accuracy of the cutting edge can be adjusted as closely as to zero.

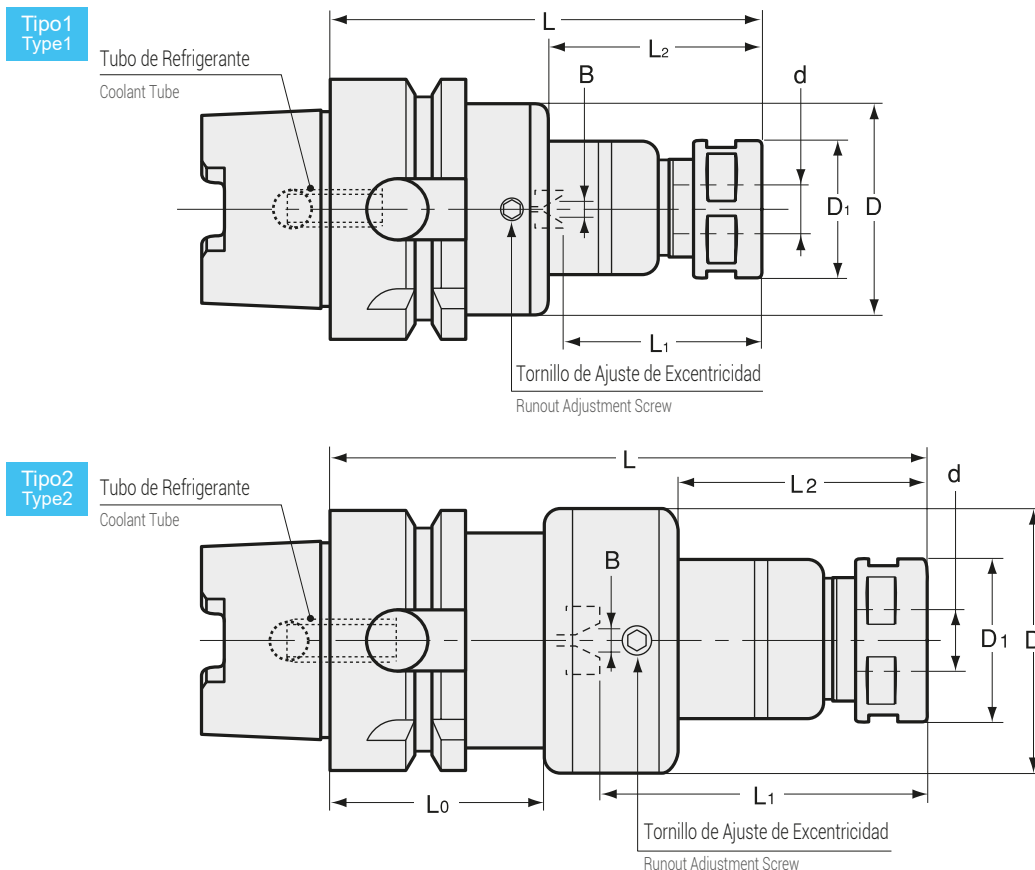





Unidad : Métrico
Unit : Metric

Código Code	Modelo Model	Tipo Type	d	L	L ₁	L ₂	B	D	D ₁	L ₀	Tuerca ciega Nut	kg	-	Boquilla Collet	Llave Inglesa Spanner	Llave Allen Wrench
5650 13007075	HSK40A -HDZ07 -75	1	0.5 ~ 7.0	75	22 ~ 38	39	0 ~ 4	34	23	—	HDP-07A	43,500				
5650 13007090	-90	1	0.5 ~ 7.0	90	22 ~ 49	54	0 ~ 4	34	23	—	HDP-07A	44,500		FDC-07	S-0	L-3T
5650 13007120	-120	1	0.5 ~ 7.0	120	22 ~ 49	84	0 ~ 4	34	23	—	HDP-07A	0.5 45,000				
5650 13009090	-HDZ09 -90	2	2.5 ~ 9.0	90	27 ~ 46	34	0 ~ 4	41	26	35	HDP-09	0.6 43,500		FDC-09	S-1L	L-3T
5650 13009120	-120	2	2.5 ~ 9.0	120	27 ~ 61	64	0 ~ 4	41	26	35	HDP-09	44,500				
5650 13012090	-HDZ12 -90	2	2.5 ~ 12.0	90	33 ~ 51	30	0 ~ 5	52	32	35	HDP-12	0.8 46,000				
5650 13012120	-120	2	2.5 ~ 12.0	120	33 ~ 74	60	0 ~ 5	52	32	35	HDP-12	1.0 46,500		FDC-12	S-3L	L-4T
5650 13012150	-150	2	2.5 ~ 12.0	150	33 ~ 74	90	0 ~ 5	52	32	35	HDP-12	50,000				
5650 13016090	-HDZ16 -90	2	3.5 ~ 16.0	90	38 ~ 54 (38 ~ 51)	30	0 ~ 6	56	36	35	HDP-16	0.9 47,000				
5650 13016120	-120	2	3.5 ~ 16.0	120	38 ~ 72	60	0 ~ 6	56	36	35	HDP-16	1.1 49,000		FDC-16	S-4L	L-4T
5650 13016150	-150	2	3.5 ~ 16.0	150	38 ~ 86	90	0 ~ 6	56	36	35	HDP-16	53,000				
5650 14007075	HSK50A -HDZ07 -75	1	0.5 ~ 7.0	75	22 ~ 32	33	0 ~ 4	41	23	—	HDP-07A	47,000				
5650 14007090	-90	1	0.5 ~ 7.0	90	22 ~ 45	48	0 ~ 4	41	23	—	HDP-07A	0.7 48,000		FDC-07	S-0	L-3T
5650 14007120	-120	1	0.5 ~ 7.0	120	22 ~ 45	78	0 ~ 4	41	23	—	HDP-07A	0.8 48,500				
5650 14009075	-HDZ09 -75	1	2.5 ~ 9.0	75	27 ~ 31	33	0 ~ 4	41	26	—	HDP-09	46,000				
5650 14009090	-90	1	2.5 ~ 9.0	90	27 ~ 47	48	0 ~ 4	41	26	—	HDP-09	0.7 47,000		FDC-09	S-1L	L-3T
5650 14009120	-120	1	2.5 ~ 9.0	120	27 ~ 61	78	0 ~ 4	41	26	—	HDP-09	0.8 48,000				
5650 14012090	-HDZ12 -90	2	2.5 ~ 12.0	90	33 ~ 42	23	0 ~ 5	52	32	42	HDP-12	1.0 49,000				
5650 14012120	-120	2	2.5 ~ 12.0	120	33 ~ 71	53	0 ~ 5	52	32	42	HDP-12	1.2 50,000		FDC-12	S-3L	L-4T
5650 14012150	-150	2	2.5 ~ 12.0	150	33 ~ 74	83	0 ~ 5	52	32	42	HDP-12	1.4 52,500				
5650 14016090	-HDZ16 -90	2	3.5 ~ 16.0	90	38 ~ 50 (38 ~ 47)	23	0 ~ 6	56	36	42	HDP-16	1.1 54,500				
5650 14016120	-120	2	3.5 ~ 16.0	120	38 ~ 65	53	0 ~ 6	56	36	42	HDP-16	1.3 55,500		FDC-16	S-4L	L-4T
5650 14016150	-150	2	3.5 ~ 16.0	150	38 ~ 86	83	0 ~ 6	56	36	42	HDP-16	1.5 57,000				

Código Code	Modelo Model	Tipo Type	d	L	L1	L2	B	D	D1	L0	Tuerca ciega Nut	kg	-	Boquilla Collet	Llave Inglesa Spanner	Llave Allen Wrench
5650 75007075	HSK63A -HDZ07 -75 -H	1	0.5 ~ 7.0	75	22 ~ 35	33	0 ~ 4	41	23	—	HDP-07A	0.9	50,000	FDC-07	S-0	L-3T
5650 75007090	-90 -H	1	0.5 ~ 7.0	90	22 ~ 45	48	0 ~ 4	41	23	—	HDP-07A		51,500			
5650 75007120	-120 -H	1	0.5 ~ 7.0	120	22 ~ 45	78	0 ~ 4	41	23	—	HDP-07A		52,500			
5650 75009075	-HDZ09 -75 -H	1	2.5 ~ 9.0	75	27 ~ 34 (27 ~ 31)	33	0 ~ 4	45	26	—	HDP-09	1.0	50,000	FDC-09	S-1L	L-3T
5650 75009090	-90 -H	1	2.5 ~ 9.0	90	27 ~ 42	48	0 ~ 4	45	26	—	HDP-09	1.0	51,500			
5650 75009120	-120 -H	1	2.5 ~ 9.0	120	27 ~ 57	78	0 ~ 4	45	26	—	HDP-09		52,500			
5650 75012090	-HDZ12 -90 -H	1	2.5 ~ 12.0	90	33 ~ 48 (33 ~ 45)	44	0 ~ 5	52	32	—	HDP-12	1.2	52,500	FDC-12	S-3L	L-4T
5650 75012120	-120 -H	1	2.5 ~ 12.0	120	33 ~ 69	74	0 ~ 5	52	32	—	HDP-12	1.3	54,000			
5650 75012150	-150 -H	1	2.5 ~ 12.0	150	33 ~ 69	104	0 ~ 5	52	32	—	HDP-12	1.5	55,000			
5650 75016090	-HDZ16 -90 -H	2	3.5 ~ 16.0	90	38 ~ 48 (38 ~ 45)	28	0 ~ 6	56	36	42	HDP-16	1.4	56,000	FDC-16	S-4L	L-4T
5650 75016120	-120 -H	2	3.5 ~ 16.0	120	38 ~ 62	58	0 ~ 6	56	36	42	HDP-16	1.6	57,500			
5650 75016150	-150 -H	2	3.5 ~ 16.0	150	38 ~ 82	88	0 ~ 6	56	36	42	HDP-16	1.8	58,500			
5650 75122120	-HDZ22A -120 -H	2	3.5 ~ 22.0	120	47 ~ 63	49	0 ~ 8	69	46	42	HDP-22	2.0	59,500	FDC-22	S-5L	L-6T
5650 75122150	-150 -H	2	3.5 ~ 22.0	150	47 ~ 93	79	0 ~ 8	69	46	42	HDP-22	2.3	61,500			
5650 77007075	HSK100A -HDZ07 -75 -H	1	0.5 ~ 7.0	75	22 ~ 27	26	0 ~ 4	41	23	—	HDP-07A		57,500	FDC-07	S-0	L-3T
5650 77007090	-90 -H	1	0.5 ~ 7.0	90	22 ~ 45	41	0 ~ 4	41	23	—	HDP-07A		58,500			
5650 77007120	-120 -H	1	0.5 ~ 7.0	120	22 ~ 45	71	0 ~ 4	41	23	—	HDP-07A		59,500			
5650 77009075	-HDZ09 -75 -H	1	2.5 ~ 9.0	75	27 ~ 28	26	0 ~ 4	45	26	—	HDP-09		57,500	FDC-09	S-1L	L-3T
5650 77009090	-90 -H	1	2.5 ~ 9.0	90	27 ~ 47 (27 ~ 44)	41	0 ~ 4	45	26	—	HDP-09	2.4	58,500			
5650 77009120	-120 -H	1	2.5 ~ 9.0	120	27 ~ 57	71	0 ~ 4	45	26	—	HDP-09		59,500			
5650 77012090	-HDZ12 -90 -H	1	2.5 ~ 12.0	90	33 ~ 41 (33 ~ 38)	41	0 ~ 5	56	32	—	HDP-12	2.6	59,500	FDC-12	S-3L	L-4T
5650 77012120	-120 -H	1	2.5 ~ 12.0	120	33 ~ 59	71	0 ~ 5	56	32	—	HDP-12		60,500			
5650 77012150	-150 -H	1	2.5 ~ 12.0	150	33 ~ 69	101	0 ~ 5	56	32	—	HDP-12	2.9	61,500			
5650 77016090	-HDZ16 -90 -H	1	3.5 ~ 16.0	90	38 ~ 41 (38)	41	0 ~ 6	62	36	—	HDP-16	2.7	61,500	FDC-16	S-4L	L-4T
5650 77016120	-120 -H	1	3.5 ~ 16.0	120	38 ~ 62	71	0 ~ 6	62	36	—	HDP-16		62,500			
5650 77016150	-150 -H	1	3.5 ~ 16.0	150	38 ~ 82	101	0 ~ 6	62	36	—	HDP-16		63,500			
5650 77122090	-HDZ22A -90 -H	1	3.5 ~ 22.0	90	56	37	—	76	46	—	HDP-22	3.0	68,000	FDC-22	S-5L	L-6T
5650 77122120	-120 -H	1	3.5 ~ 22.0	120	47 ~ 59	67	0 ~ 8	76	46	—	HDP-22	3.4	69,000			
5650 77122150	-150 -H	1	3.5 ~ 22.0	150	47 ~ 83	97	0 ~ 8	76	46	—	HDP-22		70,000			

HSK63A, HSK100A incluye barreno de cambio manual en el zanco del portaherramienta.
HSK63A, HSK100A have manual clamp holes in the shank.

1. La boquilla, llave inglesa, tornillo Allen opresor de preajuste y el tornillo de preajuste para procesos semisecos se venden por separado. El tornillo estándar de preajuste está incluido.
 2. Consulte la pág.096 para conocer la longitud mínima para insertar herramientas en caso de usar nuestras boquillas refrigerantes (OH, C o MS).
 3. L1 indica la dimensión al usarlo con un tornillo de preajuste. el valor dentro de () indica el valor que se utilizando el tornillo de preajuste con orificio hexagonal (se vende por separado).
 4. Consulte la pág. 521 para conocer el Torque recomendado para nuestros productos.
1. Collet, spanner, hexagon head preset screw, preset screw for semi-dry processing, and adjustment wrench are sold separately. Standard preset screw is included.
 2. Refer to P. 096 for minimum tool insertion length in case of using our coolant collets (OH,C or MS).
 3. "L1" indicates dimension when using with a preset screw. The value within () indicates the value when using a preset screw with a hex hole (sold separately).
 4. See P. 521 for standard tightening torque.

<p>Boquilla Collet Pág. 090-093</p> 	<p>Llave Inglesa Spanner Pág. 099</p> 	<p>Tornillo de preajuste Preset screw Pág. 098</p> 	<p>Llave Allen Hex. Wrench Pág. 099</p> 
--	--	---	--

Ejemplo para Ordenar - Ordering Example

HSK40A - HDZ 12 - 90

Interfaz y diámetro de husillo
Shank size

Máx. Diámetro Interno de boquilla
Max. collet I.D.

Longitud de Proyección
Projection length (L)

Ejemplo para Ordenar - Ordering Example

HSK63A - HDZ 07 - 75 - H

Interfaz y diámetro de husillo
Shank size

Máx. Diámetro Interno de boquilla
Max. collet I.D.

Longitud de Proyección
Projection length (L)

Barreno de Cambio Manual
Manual clamping hole

CTZ-SA

"R" Zero Holder for Large Diameter

- La excentricidad del borde de corte se puede ajustar hasta casi cero. Es adecuado para rima con diámetro amplio.
- Runout of the cutting edge can be adjusted as close as to zero. Suitable for large diameter reaming.

Tipo1
Type1

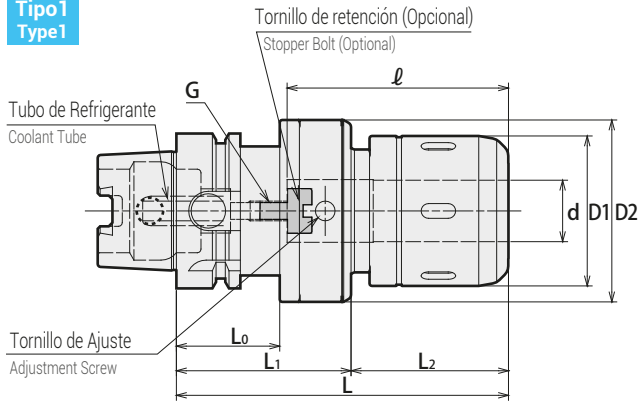

Tipo2
Type2

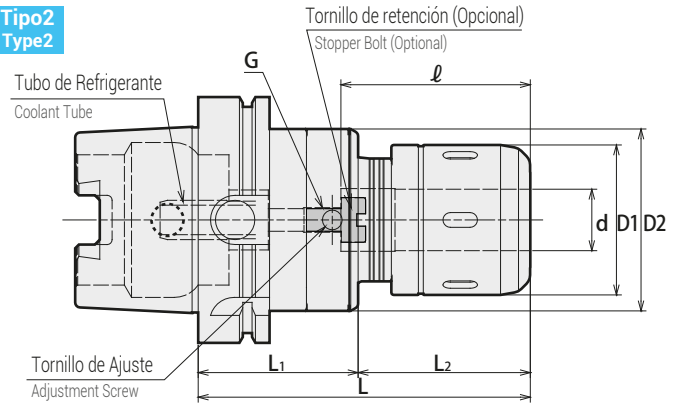

Precaución / Caution

Favor de girar el aro de sujeción en sentido contrario a las manecillas del reloj por más de 360 grados después de quitar una herramienta de corte.
Please rotate the clamping ring counterclockwise more than 360 degrees after a cutting tool is removed.

- Tubo de refrigerante incluido.
- Coolant tube is included.

Medidas Métricas - Metric Sizes

Unidad : Métrico
Unit : Metric

Código Code	Modelo Model	Tipo Type	d	L	L1	L2	D1	D2	L0	ℓ	G	kg	Max. min ⁻¹	-	Llave Inglesa Spanner	Llave Allen Hex. Wrench
5890 75425135	HSK63A -CTZ25SA -135-H * 1	1	25	135	71	64	61	74	42	80	M8 P=1.25	2.8	15,000	58,500	HS-2.5-25	L-6L (Incluida / Included)
5890 75425150	-150-H * 1	1	25	150	71	79	61	74	42	80	M8 P=1.25	3.0	13,000	60,000		
5890 75432135	-CTZ32SA -135-H * 1	1	32	135	71	64	68	80	42	105	M8 P=1.25	2.9	12,000	61,000	HS-3-32	
5890 75432150	-150-H * 1	1	32	150	71	79	68	80	42	120	M8 P=1.25	3.1	12,000	63,000		
5890 77425135	HSK100A -CTZ25SA -135-H	2	25	135	65	70	61	74	-	80	M10 P=1.5	4.2	12,500	71,000	HS-2.5-25	
5890 77425150	-150-H	2	25	150	65	85	61	74	-	80	M10 P=1.5	4.5	12,500	73,000		
5890 77432135	-CTZ32SA -135-H * 1	2	32	135	65	70	68	80	-	100	M10 P=1.5	4.5	12,000	75,000	HS-3-32	
5890 77432150	-150-H * 1	2	32	150	65	85	68	80	-	115	M10 P=1.5	4.6	12,000	78,000		
5890 77442135	-CTZ42SA -135-H * 2	1	42	135	76	59	88	99	45	100	M10 P=1.5	5.9	10,000	83,000	HS-4-42	
5890 77442150	-150-H * 2	1	42	150	76	74	88	99	45	110	M10 P=1.5	6.3	10,000	89,000		

- Al hacer su orden, indique el número de llaves inglesas que requiere. Las llaves inglesas "gratuitas" están limitadas al número de portaherramientas de fresado en su orden.
 - La llave Allen está incluida.
 - El modelo con " * 1 - * 3" no es compatible con algunos accesorios. Para obtener más información sobre los accesorios, diríjase a la tabla de la parte inferior.
- When ordering, indicate number of spanners required. "No charge" spanners are limited to number of holders on order.
 - A L-6L wrench is included.
 - The model with " * 1" and " * 2" are not compatible with some accessories. For more information about the accessories, please refer below chart.

Ejemplo para Ordenar - Ordering Example

HSK63A - CTZ 32 SA - 135 - H

Interfaz y diámetro de husillo Máx. Diámetro Interno de boquilla Longitud de Proyección Barreno de Cambio Manual
Shank size Max. collet I.D. Projection length (L) Manual clamping hole

Llave Inglesa Spanner
Pág. 073



Accesorios Accessories

Los modelos con * 1 - * 2 no pueden usarse con algunos accesorios debido a la corta ℓ longitud.
Models with * 1 - * 2 cannot be used with some accessories due to short ℓ length.

	Tornillo de retención Stopper Bolt BL (Pág.72)	Boquilla recta Straight Collet		Adaptador ahusado Morse Morse Taper Adapter		Adaptador Jacobs Jacobs Adapter	
		MC (Pág.070)	MCA (Pág.071)	MA (Pág.072)	MAB (Pág.072)	JA (Pág.073)	JAB (Pág.073)
* 1	Sí / Yes	Sí / Yes	No	Sí / Yes	Sí / Yes	Sí / Yes	Sí / Yes
* 2	Sí / Yes	Sí / Yes	No	No	No	No	No

Longitud mín de fresado Min. chucking length

Fresado directo (sin boquilla MC)
Direct Chucking (without MC Collet)

Con boquilla MC
With MC collet

D.I. del portaherramienta I.D. of Chuck	Longitud mín de inserción Min. chucking length
25,32,42	50

D.I. de la boquilla Collet I.D.	Longitud mín de inserción Min. chucking length	
	MC	MC-C, MC-OH
6,8	30	30
10,12	40	40
16,20	45	45
25	50	50
32	50	60

"R" Zero Holder (High-Balanced Type)

- La excentricidad del borde de corte se puede ajustar hasta casi cero. (Tipo de alto balance)
- Runout of the cutting edge can be adjusted as close as to zero. (High-balanced type)

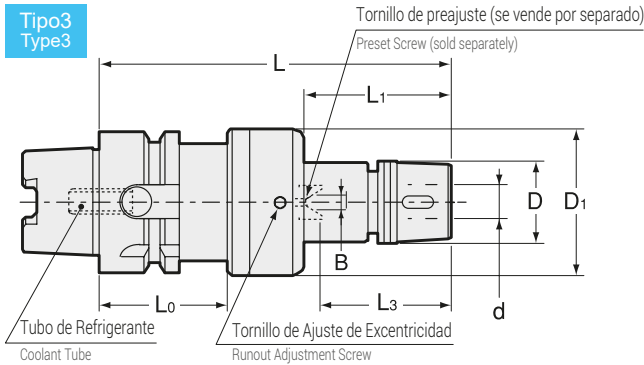
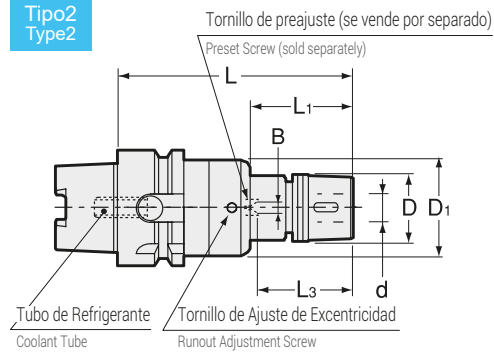
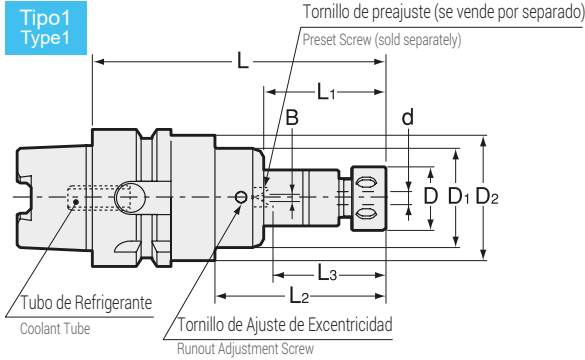

- Tubo de refrigerante incluido.
- Coolant tube is included.





Unidad : Métrico
Unit : Metric

Código Code	Modelo Model	Tipo Type	d	L	L1	L2	L3	D	D1	D2	L0	Tuerca ciega Nut	kg	Boquilla Collet	Llave Inglesa Spanner	Llave Allen Hex. Wrench
5670 13007075	HSK40A -GDZ07 -75	2	0.5 ~ 7.0	75	30	-	22 ~ 30	23	34	-	-	HDP-07A				
5670 13007090	-90	2	0.5 ~ 7.0	90	45	-	22 ~ 45	23	34	-	-	HDP-07A	0.5	FDC-07AA	S-0	L-3T
5670 13007120	-120	2	0.5 ~ 7.0	120	75	-	22 ~ 45	23	34	-	-	HDP-07A				
5670 13009090	HSK40A -GDZ09 -90	3	2.5 ~ 9.0	90	28	-	27 ~ 42	29	41	-	35	GDP-09				
5670 13009120	-120	3	2.5 ~ 9.0	120	58	-	27 ~ 57	29	41	-	35	GDP-09		FDC-09AA	S-0	L-3T
5670 13009135	-135	3	2.5 ~ 9.0	135	73	-	27 ~ 57	29	41	-	35	GDP-09				
5670 13012105	HSK40A -GDZ12 -105	3	2.5 ~ 12.0	105	39	-	33 ~ 54	34	52	-	35	GDP-12				
5670 13012120	-120	3	2.5 ~ 12.0	120	54	-	33 ~ 69	34	52	-	35	GDP-12		FDC-12AA	FK-0034	L-4T
5670 13012150	-150	3	2.5 ~ 12.0	150	84	-	33 ~ 69	34	52	-	35	GDP-12				
5670 13016105	HSK40A -GDZ16 -105	3	3.5 ~ 16.0	105	39	-	38 ~ 57	38	56	-	35	GDP-16				
5670 13016120	-120	3	3.5 ~ 16.0	120	54	-	38 ~ 72	38	56	-	35	GDP-16		FDC-16AA	FK-0034	L-4T
5670 13016150	-150	3	3.5 ~ 16.0	150	84	-	38 ~ 82	38	56	-	35	GDP-16				
5670 14007090	HSK50A -GDZ07 -90	2	0.5 ~ 7.0	90	39	-	22 ~ 45	23	41	-	-	HDP-07A				
5670 14007120	-120	2	0.5 ~ 7.0	120	69	-	22 ~ 45	23	41	-	-	HDP-07A		FDC-07AA	S-0	L-3T
5670 14007135	-135	2	0.5 ~ 7.0	135	84	-	22 ~ 45	23	41	-	-	HDP-07A				
5670 14009090	HSK50A -GDZ09 -90	2	2.5 ~ 9.0	90	39	-	27 ~ 46	29	41	-	-	GDP-09				
5670 14009120	-120	2	2.5 ~ 9.0	120	69	-	27 ~ 57	29	41	-	-	GDP-09		FDC-09AA	S-0	L-3T
5670 14009135	-135	2	2.5 ~ 9.0	135	84	-	27 ~ 57	29	41	-	-	GDP-09				
5670 14012105	HSK50A -GDZ12 -105	3	2.5 ~ 12.0	105	32	-	33 ~ 58	34	52	-	42	GDP-12				
5670 14012120	-120	3	2.5 ~ 12.0	120	47	-	33 ~ 69	34	52	-	42	GDP-12		FDC-12AA	FK-0034	L-4T
5670 14012150	-150	3	2.5 ~ 12.0	150	77	-	33 ~ 69	34	52	-	42	GDP-12				
5670 14016105	HSK50A -GDZ16 -105	3	3.5 ~ 16.0	105	32	-	38 ~ 53	38	56	-	42	GDP-16				
5670 14016120	-120	3	3.5 ~ 16.0	120	47	-	38 ~ 68	38	56	-	42	GDP-16		FDC-16AA	FK-0034	L-4T
5670 14016150	-150	3	3.5 ~ 16.0	150	77	-	38 ~ 82	38	56	-	42	GDP-16				

Código Code	Modelo Model	Tipo Type	d	L	L1	L2	L3	D	D1	D2	L0	Tuerca ciega Nut	kg	Boquilla Collet	Llave de Torque Spanner	Llave Allen Hex. Wrench
5670 75007090	HSK63A -GDZ07 -90-H	1	0.5 ~ 7.0	90	33	49	22 ~ 45	23	41	52	-	HDP-07A	1.1			
5670 75007120	-120-H	1	0.5 ~ 7.0	120	63	79	22 ~ 45	23	41	52	-	HDP-07A	1.2	FDC-07AA	S-0	L-3T
5670 75007135	-135-H	1	0.5 ~ 7.0	135	78	94	22 ~ 45	23	41	52	-	HDP-07A				
5670 75009090	HSK63A -GDZ09 -90-H	1	2.5 ~ 9.0	90	33	49	27 ~ 42	29	45	52	-	GDP-09	1.2			
5670 75009120	-120-H	1	2.5 ~ 9.0	120	63	79	27 ~ 57	29	45	52	-	GDP-09	1.3	FDC-09AA	S-0	L-3T
5670 75009135	-135-H	1	2.5 ~ 9.0	135	78	94	27 ~ 57	29	45	52	-	GDP-09	1.4			
5670 75012105	HSK63A -GDZ12 -105-H	2	2.5 ~ 12.0	105	50	-	33 ~ 54	34	52	-	-	GDP-12	1.3			
5670 75012120	-120-H	2	2.5 ~ 12.0	120	65	-	33 ~ 69	34	52	-	-	GDP-12		FDC-12AA	FK-0034	L-4T
5670 75012150	-150-H	2	2.5 ~ 12.0	150	95	-	33 ~ 69	34	52	-	-	GDP-12				
5670 75016105	HSK63A -GDZ16 -105-H	3	3.5 ~ 16.0	105	32	-	38 ~ 57	38	56	-	42	GDP-16	1.6			
5670 75016120	-120-H	3	3.5 ~ 16.0	120	47	-	38 ~ 67	38	56	-	42	GDP-16	1.7	FDC-16AA	FK-0034	L-4T
5670 75016150	-150-H	3	3.5 ~ 16.0	150	77	-	38 ~ 82	38	56	-	42	GDP-16				
5670 75022120	HSK63A -GDZ22 -120-H	3	3.5 ~ 22.0	120	43	-	47 ~ 63	49	69	-	42	GDP-22	2.1	FDC-22AA	FK-0045	L-5T
5670 75022150	-150-H	3	3.5 ~ 22.0	150	73	-	47 ~ 93	49	69	-	42	GDP-22				
5670 77007090	HSK100A -GDZ07 -90-H	1	0.5 ~ 7.0	90	30	46	22 ~ 45	23	41	84	-	HDP-07A				
5670 77007120	-120-H	1	0.5 ~ 7.0	120	60	76	22 ~ 45	23	41	84	-	HDP-07A		FDC-07AA	S-0	L-3T
5670 77007135	-135-H	1	0.5 ~ 7.0	135	75	91	22 ~ 45	23	41	84	-	HDP-07A				
5670 77009090	HSK100A -GDZ09 -90-H	1	2.5 ~ 9.0	90	30	46	27 ~ 45	29	45	84	-	GDP-09				
5670 77009120	-120-H	1	2.5 ~ 9.0	120	60	76	27 ~ 57	29	45	84	-	GDP-09		FDC-09AA	S-0	L-3T
5670 77009135	-135-H	1	2.5 ~ 9.0	135	75	91	27 ~ 57	29	45	84	-	GDP-09				
5670 77012105	HSK100A -GDZ12 -105-H	1	2.5 ~ 12.0	105	41	61	33 ~ 45	34	56	84	-	GDP-12				
5670 77012120	-120-H	1	2.5 ~ 12.0	120	56	76	33 ~ 60	34	56	84	-	GDP-12		FDC-12AA	FK-0034	L-4T
5670 77012150	-150-H	1	2.5 ~ 12.0	150	86	106	33 ~ 69	34	56	84	-	GDP-12				
5670 77016105	HSK100A -GDZ16 -105-H	1	3.5 ~ 16.0	105	41	61	38 ~ 47	38	62	84	-	GDP-16				
5670 77016120	-120-H	1	3.5 ~ 16.0	120	56	76	38 ~ 62	38	62	84	-	GDP-16		FDC-16AA	FK-0034	L-4T
5670 77016150	-150-H	1	3.5 ~ 16.0	150	86	106	38 ~ 82	38	62	84	-	GDP-16				
5670 77022105	HSK100A -GDZ22 -105-H	1	3.5 ~ 22.0	105	37	61	65	49	76	84	-	GDP-22				
5670 77022120	-120-H	1	3.5 ~ 22.0	120	52	76	47 ~ 57	49	76	84	-	GDP-22		FDC-22AA	FK-0045	L-5T
5670 77022150	-150-H	1	3.5 ~ 22.0	150	82	106	47 ~ 87	49	76	84	-	GDP-22				

1. La boquilla, el tornillo de preajuste, la llave Allen y la llave de torque se venden por separado.
2. Siempre use boquillas de categoría "AA".
3. Consulte la pág. 096 para conocer la longitud mínima para insertar herramientas en caso de usar nuestras boquillas refrigerantes (OH, C o MS).
4. L2 indica la dimensión cuando se use con un tornillo de preajuste.
5. Consulte la pág. 521 para conocer el Torque recomendado para nuestros productos.

1. Collet, preset screw, spanner and adjustment wrench are sold separately.
2. Always use AA class collet.
3. Refer to P.096 for minimum tool insertion length in case of using our coolant collets (OH,C or MS).
4. "L3" dimensions in brackets are for using preset screw.
5. See P.521 for standard Tightening Torque.

Boquilla Collet Pág. 090-093	Llave Inglesa Spanner Pág. 099	Tornillo de preajuste Preset screw Pág. 098	Llave Allen Hex. Wrench Pág. 099
			

Ejemplo para Ordenar - Ordering Example

HSK40A - GDZ 07 - 90

Interfaz y diámetro de husillo Shank size	Max. Diámetro Interno de boquilla Max. collet I.D.	Longitud de Proyección Projection length (L)
--	---	---

Ejemplo para Ordenar - Ordering Example

HSK63A - GDZ 07 - 90 - H

Interfaz y diámetro de husillo Shank size	Max. Diámetro Interno de boquilla Max. collet I.D.	Longitud de Proyección Projection length (L)	Barreno de Cambio Manual Manual clamping hole
--	---	---	--

"R" Zero Holder For Small Diameters

- Portaherramienta con mecanismo para ajustar la excentricidad. Adecuado para barrenado en espacios angostos.
- Holder with runout adjustment mechanism. Suitable for drilling in tight space.

Tornillo de preajuste

Portaherramienta ERC8: se vende por separado
En portaherramientas de mayor diámetro de 8mm: incluido

Preset Screw

ERC8 Holder : Sold separately
Other Holder : Included

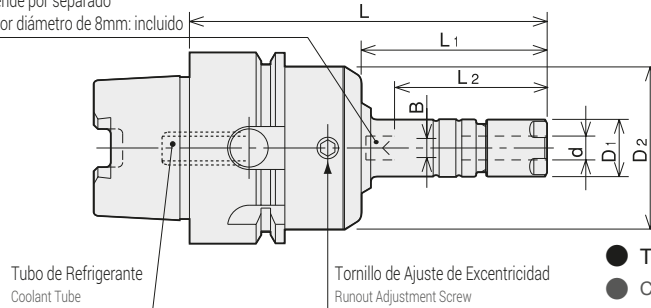

Tubo de Refrigerante
Coolant Tube

Tornillo de Ajuste de Excentricidad
Runout Adjustment Screw

- Tubo de refrigerante incluido.
- Coolant tube is included.

Unidad : Métrico
Unit : Metric

Código Code	Modelo Model	d	L	L1	B	L2	D1	D2	Tuerca ciega Nut	Boquilla Collet	Llave Inglesa Spanner	Llave Allen Hex. Wrench
5680 00308075	HSK40A -ERZ8 -75	0.5 ~ 5.0	75	39	— (0 ~ 3.1)	³³ (19 ~ 29)	12	34	ERP-8			
5680 00308090	-90	0.5 ~ 5.0	90	54	— (0 ~ 3.1)	³³ (19 ~ 29)	12	34	ERP-8	ER8	S-8E	L-3T
5680 00308105	-105	0.5 ~ 5.0	105	69	— (0 ~ 3.1)	³³ (19 ~ 29)	12	34	ERP-8			
5680 00310075	HSK40A -ERZ11S-75	0.5 ~ 7.0	75	39	0 ~ 4	22 ~ 35	16	34	ERP-11S			
5680 00310090	-90	0.5 ~ 7.0	90	54	0 ~ 4	22 ~ 42	16	34	ERP-11S	FDC-07	S-11E	L-3T
5680 00310105	-105	0.5 ~ 7.0	105	69	0 ~ 4	22 ~ 42	16	34	ERP-11S			
5680 00408075	HSK50A -ERZ8 -75	0.5 ~ 5.0	75	33	— (0 ~ 3.1)	³³ (19 ~ 28)	12	34	ERP-8			
5680 00408090	-90	0.5 ~ 5.0	90	48	— (0 ~ 3.1)	³³ (19 ~ 29)	12	34	ERP-8	ER8	S-8E	L-3T
5680 00408105	-105	0.5 ~ 5.0	105	63	— (0 ~ 3.1)	³³ (19 ~ 29)	12	34	ERP-8			
5680 00410075	HSK50A -ERZ11S-75	0.5 ~ 7.0	75	33	0 ~ 4	22 ~ 29	16	34	ERP-11S			
5680 00410090	-90	0.5 ~ 7.0	90	48	0 ~ 4	22 ~ 42	16	34	ERP-11S	FDC-07	S-11E	L-3T
5680 00410105	-105	0.5 ~ 7.0	105	63	0 ~ 4	22 ~ 42	16	34	ERP-11S			
5680 00508075	HSK63A -ERZ8 -75-H	0.5 ~ 5.0	75	33	— (0 ~ 3.1)	³³ (19 ~ 26)	12	34	ERP-8			
5680 75008090	-90-H	0.5 ~ 5.0	90	48	— (0 ~ 3.1)	³³ (19 ~ 29)	12	34	ERP-8	ER8	S-8E	L-3T
5680 75008120	-120-H	0.5 ~ 5.0	120	78	— (0 ~ 3.1)	³³ (19 ~ 29)	12	34	ERP-8			
5680 75010075	HSK63A -ERZ11S-75-H	0.5 ~ 7.0	75	33	0 ~ 4	22 ~ 32	16	34	ERP-11S			
5680 75010090	-90-H	0.5 ~ 7.0	90	48	0 ~ 4	22 ~ 42	16	34	ERP-11S	FDC-07	S-11E	L-3T
5680 75010120	-120-H	0.5 ~ 7.0	120	78	0 ~ 4	22 ~ 42	16	34	ERP-11S			

1. La boquilla, el tornillo de preajuste, la llave Allen y la llave de torque se venden por separado.
2. El ES8, un tornillo de preajuste para el ERZ8, se vende por separado. El ERZ11S incluye un tornillo estándar de preajuste HDS-07A-ES11.
3. Las dimensiones "B" y "L2" entre corchetes son para usar el tornillo de preajuste ES8.
4. Consulte la pág. 096 para conocer la longitud mínima para insertar herramientas en caso de usar nuestras boquillas refrigerantes.
5. Diríjase a la pág. 521 para el Torque recomendado para nuestros productos.

1. Collet ,spanner and adjustment wrench are sold separately.
2. ES8, a preset screw for ERZ8, is sold separately. ERZ11S includes a standard preset screw HDS-07A-ES11.
3. " B " and " L2 " dimensions in brackets are for using ES8 preset screw.
4. Refer to P.096 for minimum tool insertion length in case of using our coolant collets.
5. See P.521 for standard Tightening Torque.

Ejemplo para Ordenar - Ordering Example

HSK40A - ERZ	8	- 75
Interfaz y diámetro de husillo Shank size	Máx. Diámetro Interno de boquilla Max. collet I.D.	Longitud de Proyección Projection length (L)

Boquilla Collet	Llave de Torque Spanner	Tornillo de preajuste Preset screw	Llave Allen Hex. Wrench
Pág. 090-093	Pág. 099	Pág. 098	Pág. 099

Ejemplo para Ordenar - Ordering Example

HSK63A - ERZ	8	- 75	- H
Interfaz y diámetro de husillo Shank size	Máx. Diámetro Interno de boquilla Max. collet I.D.	Longitud de Proyección Projection length (L)	Barreno de Cambio Manual Manual clamping hole

PHZ · S

Slim Hydro "R" Zero Holder

Tipo1
Type1

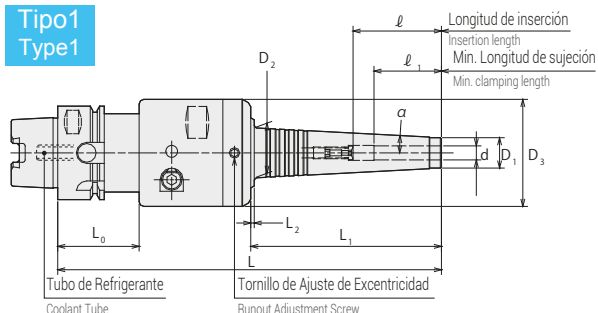

Tipo2
Type2

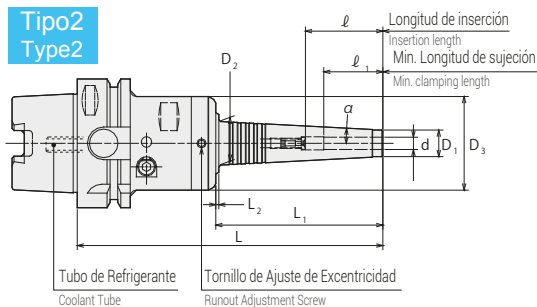

Tipo3
Type3

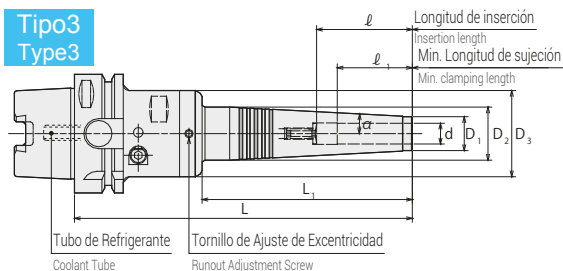

- Tubo de refrigerante incluido.
- Coolant tube is included.

Medidas Métricas - Metric Sizes

Unidad : Métrico
Unit : Metric

Código Code	Modelo Model	Tipo Type	d	L	L1	L2	D1	D2	D3	L0	ℓ	ℓ1	α	Llave Allen para el tornillo de accionamiento (Opcional) Hex. wrench for the actuating screw (Optional)	Llave Allen para Tornillos de ajuste de excentricidad (Opcional) Hex. wrench for runout adjustment screw (Optional)		
5930 13006165	HSK40A -PHZ06S -165	1	6	165	82	1.5	13	21.5	46	35	37	29	3°	L-4T	L-3T		
5930 13007165	HSK40A -PHZ07S -165	1	7	165	82	1.5	14	22.5	46	35	37	29	3°				
5930 13008165	HSK40A -PHZ08S -165	1	8	165	82	1.5	15	23.5	46	35	50	29	3°				
5930 13009165	HSK40A -PHZ09S -165	1	9	165	82	1.5	16	24.5	46	35	50	40	3°				
5930 13010165	HSK40A -PHZ10S -165	1	10	165	82	1.5	17	25.5	46	35	50	40	3°				
5930 13011165	HSK40A -PHZ11S -165	1	11	165	82	1.5	18	26.5	46	35	50	40	3°				
5930 13012165	HSK40A -PHZ12S -165	1	12	165	82	—	19	27.4	46	35	70	40	3°	L-4T	L-3T		
5930 75006150	HSK63A -PHZ06S -150-H	2	6	150	82	1.5	13	21.5	46	—	37	29	3°				
5930 75006180	-180-H	2	6	180	112	1.5	13	24.6	46	—	37	29	3°				
5930 75007150	HSK63A -PHZ07S -150-H	2	7	150	82	1.5	14	22.5	46	—	37	29	3°				
5930 75007180	-180-H	2	7	180	112	1.5	14	25.6	46	—	37	29	3°				
5930 75008150	HSK63A -PHZ08S -150-H	2	8	150	82	1.5	15	23.5	46	—	50	29	3°				
5930 75008180	-180-H	2	8	180	112	1.5	15	26.6	46	—	50	29	3°	L-4T	L-3T		
5930 75009150	HSK63A -PHZ09S -150-H	2	9	150	82	1.5	16	24.5	46	—	50	40	3°				
5930 75009180	-180-H	2	9	180	112	—	16	27.6	46	—	50	40	3°				
5930 75010150	HSK63A -PHZ10S -150-H	2	10	150	82	1.5	17	25.5	46	—	50	40	3°				
5930 75010180	-180-H	3	10	180	112	—	17	28.2	46	—	50	40	3°				
5930 75011150	HSK63A -PHZ11S -150-H	2	11	150	82	1.5	18	26.5	46	—	50	40	3°			L-4T	L-3T
5930 75011180	-180-H	3	11	180	112	—	18	28.2	46	—	50	40	3°				
5930 75012150	HSK63A -PHZ12S -150-H	2	12	150	82	—	19	27.4	46	—	70	40	3°				
5930 75012180	-180-H	3	12	180	112	—	19	28.2	46	—	70	40	3°				
5930 77006165	HSK100A -PHZ06S -165-H	2	6	165	82	1.5	13	21.5	46	—	37	29	3°	L-4T	L-3T		
5930 77006195	-195-H	2	6	195	112	1.5	13	24.6	46	—	37	29	3°				
5930 77007165	HSK100A -PHZ07S -165-H	2	7	165	82	1.5	14	22.5	46	—	37	29	3°				
5930 77007195	-195-H	2	7	195	112	1.5	14	25.6	46	—	37	29	3°				
5930 77008165	HSK100A -PHZ08S -165-H	2	8	165	82	1.5	15	23.5	46	—	50	29	3°				
5930 77008195	-195-H	2	8	195	112	1.5	15	26.6	46	—	50	29	3°				
5930 77009165	HSK100A -PHZ09S -165-H	2	9	165	82	1.5	16	24.5	46	—	50	40	3°	L-4T	L-3T		
5930 77009195	-195-H	2	9	195	112	—	16	27.6	46	—	50	40	3°				
5930 77010165	HSK100A -PHZ10S -165-H	2	10	165	82	1.5	17	25.5	46	—	50	40	3°				
5930 77010195	-195-H	3	10	195	112	—	17	28.2	46	—	50	40	3°				
5930 77011165	HSK100A -PHZ11S -165-H	2	11	165	82	1.5	18	26.5	46	—	50	40	3°				
5930 77011195	-195-H	3	11	195	112	—	18	28.2	46	—	50	40	3°				
5930 77012165	HSK100A -PHZ12S -165-H	2	12	165	82	—	19	27.4	46	—	70	40	3°	L-4T	L-3T		
5930 77012195	-195-H	3	12	195	112	—	19	28.2	46	—	70	40	3°				

1. La tolerancia del diámetro del zanco de la herramienta debe estar dentro de h6.
2. No deje el portaherramienta con el tornillo de mando ajustado cuando el portaherramienta esté vacío.

1. Tool shank diameter tolerance must be within h6.
2. Do not leave the holder with actuating screw tightened when the chuck is empty.

Ejemplo para Ordenar - Ordering Example

HSK40A - PHZ 06 S - 165

Interfaz y diámetro de husillo	Diámetro Interno	Longitud de Proyección
Shank size	I.D. (d)	Projection length (L)

Ejemplo para Ordenar - Ordering Example

HSK63A - PHZ 06 S - 150 - H

Interfaz y diámetro de husillo	Máx. Diámetro Interno de boquilla	Longitud de Proyección	Barreno de Cambio Manual
Shank size	Max. collet I.D.	Projection length (L)	Manual clamping hole

**Torque de ajuste (llave Allen : Pág. 520)
Tightening torque (Torque wrench : p.520)**

Modelo Model	I.D. (d)		Torque de ajuste Tightening torque (Nm)
	mm	Inch	
PHZ-S	06 ~ 12	—	9 ~ 10

Llave Allen
Hex. Wrench

Pág. 099



- BT
- CAT
- AHO
- HSK-A/E/F/C
- HSK-T
- C
- UTS
- Máquinas Especializadas
Specialized Machine
- Equipo Relacionado
Related Equipment
- Taladro de Biselado & de Casquillo
Bush & Chamfering Drill
- Milling Chuck
- Collet Holder
- "R" Zero Holder
- Hydraulic Chuck
- Shrink Fit
- Tapping Chuck
- Arbors
- Function Holder
- HSK-E
- HSK-F
- HSK-C
- Dimensions

PHC-A



Power Hydro Chuck

- Portaherramienta Hidráulico con capacidad para boquillas. Adecuado para herramientas de corte de alta precisión.
- Hydro chuck with collet holder flexibility. Suitable for high precision cutting.

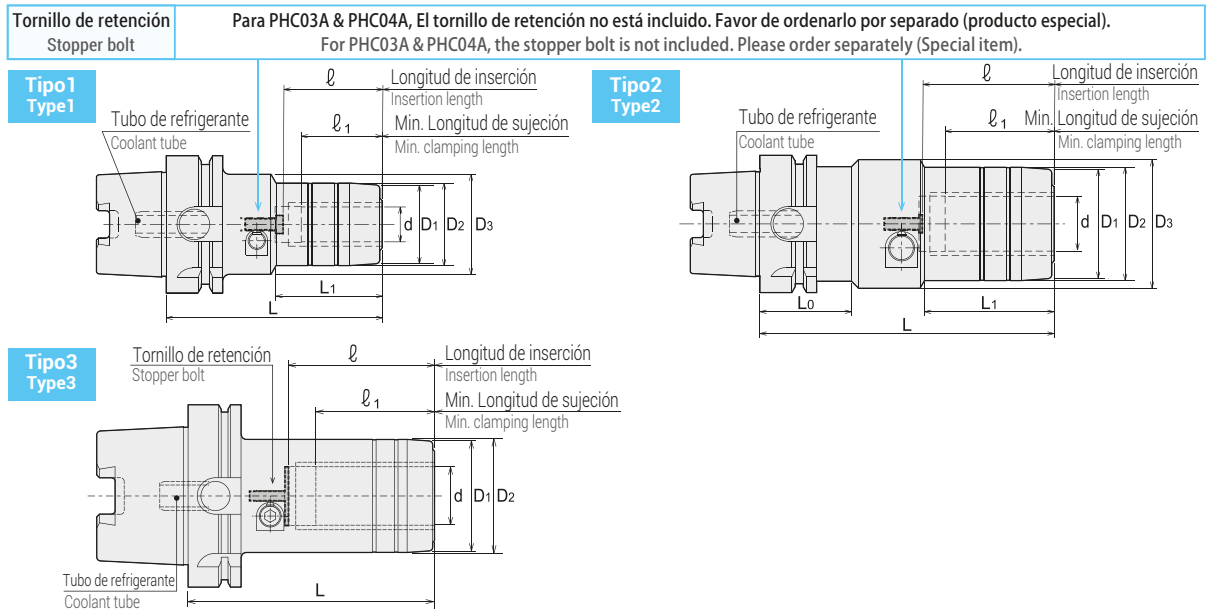

Medidas en Pulgadas - Inch Sizes

Unidad : Pulgadas
Unit : Inch

Código Code	Modelo Model	Tipo Type	d	L	L ₁	D ₁	D ₂	D ₃	L ₀	l	l ₁	Llave Allen (Opcional) Hex. Wrench (Optional)
573200757000	HSK63A -PHC0125A - 65-H	1	0.125	2.559	0.800	—	0.945	1.791	—	1.102	0.709	L-4T (4mm)
573075308075	- 75-H	1	0.25	2.953	1.190	0.945	1.024	1.811	—	1.338	1.142	
573075308120	- 120-H	1	0.25	4.725	1.624	0.945	1.024	1.811	—	1.771	1.142	
573075310075	-PHC0312A - 75-H	1	0.312	2.953	1.213	1.024	1.103	1.811	—	1.338	1.142	
573075310120	- 120-H	1	0.312	4.725	1.646	1.024	1.103	1.811	—	1.771	1.142	
573075312090	-PHC0375A - 90-H	1	0.375	3.544	1.758	1.103	1.182	2.048	—	1.968	1.575	
573075312120	- 120-H	1	0.375	4.725	2.546	1.103	1.182	2.048	—	2.755	1.575	
573075316090	-PHC0500A - 90-H *	1	0.5	3.544	1.826	1.339	1.418	2.048	—	1.968	1.575	
573075316120	- 120-H *	1	0.5	4.725	2.614	1.339	1.418	2.048	—	2.755	1.575	
573075320090	-PHC0625A - 90-H	1	0.625	3.544	1.849	1.418	1.496	2.048	—	1.968	1.575	
573075320120	- 120-H	1	0.625	4.725	2.637	1.418	1.496	2.048	—	2.755	1.575	
573075324090	-PHC0750A - 90-H *	1	0.75	3.544	1.963	1.575	1.654	1.811	—	1.968	1.575	
573075324120	- 120-H *	1	0.75	4.725	2.750	1.575	1.654	1.811	—	2.755	1.575	
573075332135	-PHC1000A - 135-H	2	1	5.315	2.342	1.969	2.048	2.323	1.654	2.362	1.969	L-6T (6mm)
573075332150	- 150-H	2	1	5.906	3.130	1.969	2.048	2.323	1.654	3.149	1.969	
573075340135	-PHC1250A - 135-H	2	1.25	5.315	1.668	2.363	2.441	3.347	1.654	3.149	2.56	
573075340150	- 150-H	2	1.25	5.906	—	2.363	2.441	—	1.654	3.149	2.56	
573200765000	HSK100A -PHC0250A - 90-H	1	0.25	3.544	1.190	0.945	1.024	1.811	—	1.338	1.142	L-4T (4mm)
573200763000	- 120-H	1	0.25	4.725	1.624	0.945	1.024	1.811	—	1.771	1.142	
573200764000	- 150-H	1	0.25	5.906	1.624	0.945	1.024	1.811	—	1.771	1.142	
573200768000	-PHC0312A - 90-H	1	0.312	3.543	1.213	1.024	1.102	1.811	—	1.339	1.142	
573200766000	- 120-H	1	0.312	4.724	1.646	1.024	1.102	1.811	—	1.772	1.142	
573200767000	- 150-H	1	0.312	5.906	1.646	1.024	1.102	1.811	—	1.772	1.142	
573200769000	-PHC0375A - 105-H	1	0.375	4.134	1.758	1.103	1.182	2.048	—	1.968	1.575	
573200770000	- 135-H	1	0.375	5.315	2.546	1.103	1.182	2.048	—	2.755	1.575	
573200771000	- 165-H	1	0.375	6.496	2.546	1.103	1.182	2.048	—	2.755	1.575	
573200777000	-PHC0500A - 105-H *	1	0.5	4.134	1.826	1.339	1.418	2.048	—	1.968	1.575	
573200778000	- 135-H	1	0.5	5.315	2.614	1.339	1.418	2.048	—	2.755	1.575	
573200779000	- 165-H	1	0.5	6.496	2.614	1.339	1.418	2.048	—	2.755	1.575	
573200771000	-PHC0625A - 105-H	1	0.625	4.134	1.849	1.418	1.496	2.048	—	1.968	1.575	
573200773000	- 135-H	1	0.625	5.315	2.637	1.418	1.496	2.048	—	2.755	1.575	
573200774000	- 165-H	1	0.625	6.496	2.637	1.418	1.496	2.048	—	2.755	1.575	
573200780000	-PHC0750A - 105-H *	1	0.75	4.134	1.963	1.575	1.654	1.811	—	1.968	1.575	
573200781000	- 135-H *	1	0.75	5.315	2.750	1.575	1.654	1.811	—	2.755	1.575	
573200782000	- 165-H *	1	0.75	6.496	2.750	1.575	1.654	1.811	—	2.755	1.575	
573200775000	-PHC1000A - 120-H	1	1	4.725	2.347	1.969	2.048	2.441	—	2.519	1.969	L-6T (6mm)
573200776000	- 165-H	1	1	6.496	3.135	1.969	2.048	2.441	—	3.149	1.969	
573200783000	-PHC1250A - 135-H	3	1.25	5.315	—	2.363	2.441	—	—	3.149	2.56	
573200784000	- 165-H	3	1.25	6.496	—	2.363	2.441	—	—	3.149	2.56	

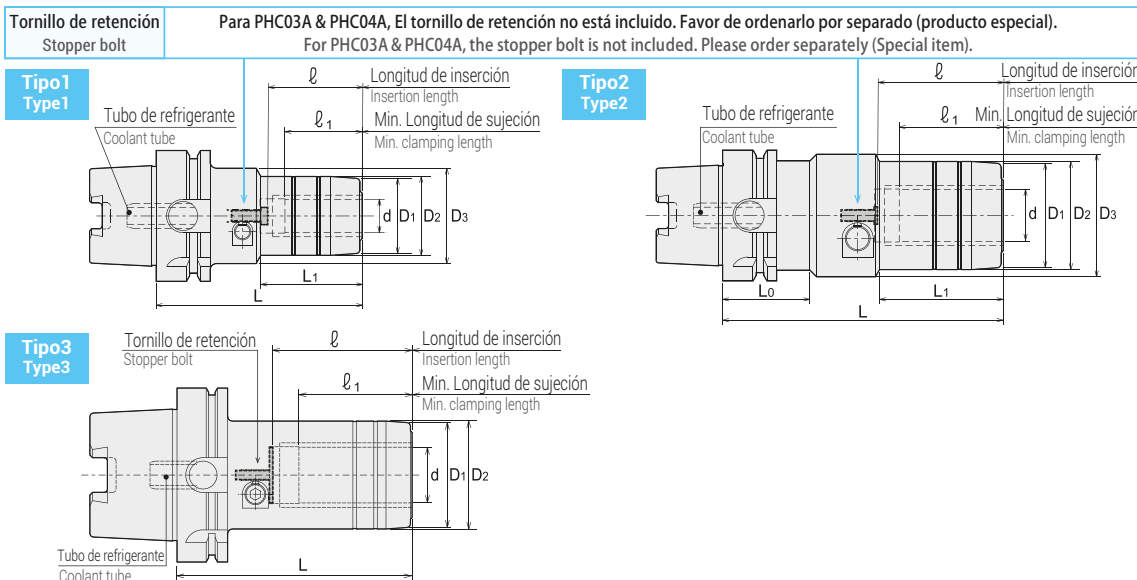

Medidas Métricas - Metric Sizes

Unidad : Métrico
Unit : Metric

Código Code	Modelo Model	Tipo Type	d	L	L ₁	D ₁	D ₂	D ₃	L ₀	ℓ	ℓ ₁	Max. min ⁻¹	Kg	Llave Allen (Opcional) Hex. Wrench (Optional)
5730 13203075	HSK40A -PHC03A - 75	3	3	75	19.8	—	24	46	35	27	18	30,000	0.6	L-4T (4mm)
5730 13204080	-PHC04A - 80	3	4	80	25.1	—	25	46	35	29	24	30,000	0.6	
5730 13206090	-PHC06A - 90	2	6	90	30	24	26	46	35	34	29	28,000	0.7	
5730 13207090	-PHC07A - 90	2	7	90	30	26	28	46	35	34	29	28,000	0.7	
5730 13208090	-PHC08A - 90	2	8	90	30	26	28	46	35	34	29	27,000	0.7	
5730 13209105	-PHC09A - 105	2	9	105	44	28	30	52	35	50	40	26,000	0.9	
5730 13210105	-PHC10A - 105	2	10	105	44	28	30	52	35	50	40	26,000	0.9	
5730 13211105	-PHC11A - 105	2	11	105	45	30	32	52	35	50	40	25,000	0.9	
5730 13212105	-PHC12A - 105 *	2	12	105	45	30	32	52	35	50	40	25,000	0.9	
5730 13213105	-PHC13A - 105	2	13	105	46	34	36	52	35	50	40	25,000	1.0	
5730 13214105	-PHC14A - 105	2	14	105	46	34	36	52	35	50	40	25,000	1.0	
5730 13215105	-PHC15A - 105	2	15	105	46	36	38	52	35	50	40	25,000	1.0	
5730 13216105	-PHC16A - 105	2	16	105	46	36	38	52	35	50	40	24,000	1.0	
5730 13220105	-PHC20A - 105 *	2	20	105	49	40	42	46	35	50	40	20,000	1.0	
5730 13225120	-PHC25A - 120	2	25	120	59	50	52	59	35	60	50	16,000	1.5	L-6T (6mm)
5730 14203080	HSK50A -PHC03A - 80	3	3	80	19.8	—	24	46	42	27	18	25,000	0.9	L-4T (4mm)
5730 14204085	-PHC04A - 85	3	4	85	25.1	—	25	46	42	29	24	25,000	0.9	
5730 14206090	-PHC06A - 90	2	6	90	30	24	26	46	41	34	29	25,000	0.9	
5730 14207090	-PHC07A - 90	2	7	90	30	26	28	46	41	34	29	25,000	0.9	
5730 14208090	-PHC08A - 90	2	8	90	30	26	28	46	41	34	29	25,000	0.9	
5730 14209105	-PHC09A - 105	2	9	105	44	28	30	52	41	50	40	25,000	1.0	
5730 14210105	-PHC10A - 105	2	10	105	44	28	30	52	41	50	40	25,000	1.0	
5730 14211105	-PHC11A - 105	2	11	105	45	30	32	52	41	50	40	25,000	1.1	
5730 14212105	-PHC12A - 105 *	2	12	105	45	30	32	52	41	50	40	25,000	1.1	
5730 14213105	-PHC13A - 105	2	13	105	46	34	36	52	41	50	40	25,000	1.1	
5730 14214105	-PHC14A - 105	2	14	105	46	34	36	52	41	50	40	25,000	1.1	
5730 14215105	-PHC15A - 105	2	15	105	46	36	38	52	41	50	40	25,000	1.2	
5730 14216105	-PHC16A - 105	2	16	105	46	36	38	52	41	50	40	25,000	1.1	
5730 14220105	-PHC20A - 105 *	2	20	105	49	40	42	46	41	50	40	20,000	1.1	
5730 14225135	-PHC25A - 135	2	25	135	59	50	52	59	42	60	50	16,000	1.9	L-6T (6mm)
5730 75203065	HSK63A -PHC03A - 65-H	1	3	65	19.8	—	24	46	—	27	18	20,500	1.0	L-4T (4mm)
5730 75204070	-PHC04A - 70-H	1	4	70	25.1	—	25	46	—	29	24	20,500	1.0	
5730 75206075	-PHC06A - 75-H	1	6	75	30	24	26	46	—	34	29	20,500	1.0	
5730 75206120	- 120-H	1	6	120	41	24	26	46	—	45	29	20,500	1.5	
5730 75207075	-PHC07A - 75-H	1	7	75	30	26	28	46	—	34	29	20,500	1.0	
5730 75207120	- 120-H	1	7	120	41	26	28	46	—	45	29	20,500	1.5	
5730 75208075	-PHC08A - 75-H	1	8	75	30	26	28	46	—	34	29	20,500	1.0	
5730 75208120	- 120-H	1	8	120	41	26	28	46	—	45	29	20,500	1.5	
5730 75209090	-PHC09A - 90-H	1	9	90	44	28	30	52	—	50	40	20,500	1.2	
5730 75209120	- 120-H	1	9	120	64	28	30	52	—	70	40	20,500	1.4	
5730 75210090	-PHC10A - 90-H	1	10	90	44	28	30	52	—	50	40	20,500	1.2	
5730 75210120	- 120-H	1	10	120	64	28	30	52	—	70	40	20,500	1.4	

Código Code	Modelo Model	Tipo Type	d	L	L ₁	D ₁	D ₂	D ₃	L ₀	ℓ	ℓ ₁	Max. min ⁻¹	Kg	Llave Allen (Opcional) Hex. Wrench (Optional)
5730 75211090	HSK63A-PHC11A -90-H	1	11	90	45	30	32	52	—	50	40	20,500	1.2	L-4T (4mm)
5730 75211120	-120-H	1	11	120	65	30	32	52	—	70	40	20,500	1.4	
5730 75212090	-PHC12A -90-H *	1	12	90	45	30	32	52	—	50	40	20,500	1.2	
5730 75212120	-120-H *	1	12	120	65	30	32	52	—	70	40	20,500	1.4	
5730 75213090	-PHC13A -90-H	1	13	90	46	34	36	52	—	50	40	20,500	1.2	
5730 75213120	-120-H	1	13	120	66	34	36	52	—	70	40	20,500	1.5	
5730 75214090	-PHC14A -90-H	1	14	90	46	34	36	52	—	50	40	20,500	1.2	
5730 75214120	-120-H	1	14	120	66	34	36	52	—	70	40	20,500	1.5	
5730 75215090	-PHC15A -90-H	1	15	90	46	36	38	52	—	50	40	20,500	1.3	
5730 75215120	-120-H	1	15	120	66	36	38	52	—	70	40	20,500	1.6	
5730 75216090	-PHC16A -90-H	1	16	90	46	36	38	52	—	50	40	20,500	1.3	
5730 75216120	-120-H	1	16	120	66	36	38	52	—	70	40	20,500	1.6	
5730 75220090	-PHC20A -90-H *	1	20	90	49	40	42	46	—	50	40	20,500	1.3	
5730 75220120	-120-H *	1	20	120	69	40	42	46	—	70	40	20,500	1.5	
5730 75225135	-PHC25A -135-H	2	25	135	59	50	52	59	42	60	50	16,000	2.3	
5730 75225150	-150-H	2	25	150	79	50	52	59	42	80	50	16,000	2.5	
5730 75232135	-PHC32A -135-H	2	32	135	42	60	62	85	42	80	65	12,000	3.1	
5730 75232150	-150-H	2	32	150	108	60	62	62	42	80	65	12,000	2.9	
5730 77206090	HSK100A-PHC06A -90-H	1	6	90	30	24	26	46	—	34	29	12,500	2.6	
5730 77206120	-120-H	1	6	120	41	24	26	46	—	45	29	12,500	2.8	
5730 77206150	-150-H	1	6	150	41	24	26	46	—	45	29	12,500	3.2	
5730 77207090	-PHC07A -90-H	1	7	90	30	26	28	46	—	34	29	12,500	2.6	
5730 77207120	-120-H	1	7	120	41	26	28	46	—	45	29	12,500	2.8	
5730 77207150	-150-H	1	7	150	41	26	28	46	—	45	29	12,500	3.2	
5730 77208090	-PHC08A -90-H	1	8	90	30	26	28	46	—	34	29	12,500	2.6	
5730 77208120	-120-H	1	8	120	41	26	28	46	—	45	29	12,500	2.8	
5730 77208150	-150-H	1	8	150	41	26	28	46	—	45	29	12,500	3.2	
5730 77209105	-PHC09A -105-H	1	9	105	44	28	30	52	—	50	40	12,500	2.7	
5730 77209135	-135-H	1	9	135	64	28	30	52	—	70	40	12,500	3.0	
5730 77209165	-165-H	1	9	165	64	28	30	52	—	70	40	12,500	3.5	
5730 77210105	-PHC10A -105-H	1	10	105	44	28	30	52	—	50	40	12,500	2.7	
5730 77210135	-135-H	1	10	135	64	28	30	52	—	70	40	12,500	3.0	
5730 77210165	-165-H	1	10	165	64	28	30	52	—	70	40	12,500	3.5	
5730 77211105	-PHC11A -105-H	1	11	105	45	30	32	52	—	50	40	12,500	2.7	
5730 77211135	-135-H	1	11	135	65	30	32	52	—	70	40	12,500	3.0	
5730 77211165	-165-H	1	11	165	65	30	32	52	—	70	40	12,500	3.5	
5730 77212105	-PHC12A -105-H *	1	12	105	45	30	32	52	—	50	40	12,500	2.7	
5730 77212135	-135-H *	1	12	135	65	30	32	52	—	70	40	12,500	3.0	
5730 77212165	-165-H *	1	12	165	65	30	32	52	—	70	40	12,500	3.5	
5730 77213105	-PHC13A -105-H	1	13	105	46	34	36	52	—	50	40	12,500	2.8	
5730 77213135	-135-H	1	13	135	66	34	36	52	—	70	40	12,500	3.1	
5730 77213165	-165-H	1	13	165	66	34	36	52	—	70	40	12,500	3.5	
5730 77214105	-PHC14A -105-H	1	14	105	46	34	36	52	—	50	40	12,500	2.8	
5730 77214135	-135-H	1	14	135	66	34	36	52	—	70	40	12,500	3.1	
5730 77214165	-165-H	1	14	165	66	34	36	52	—	70	40	12,500	3.5	
5730 77215105	-PHC15A -105-H	1	15	105	46	36	38	52	—	50	40	12,500	2.8	
5730 77215135	-135-H	1	15	135	66	36	38	52	—	70	40	12,500	3.1	
5730 77215165	-165-H	1	15	165	66	36	38	52	—	70	40	12,500	3.6	
5730 77216105	-PHC16A -105-H	1	16	105	46	36	38	52	—	50	40	12,500	2.8	
5730 77216135	-135-H	1	16	135	66	36	38	52	—	70	40	12,500	3.1	
5730 77216165	-165-H	1	16	165	66	36	38	52	—	70	40	12,500	3.6	
5730 77220105	-PHC20A -105-H *	1	20	105	49	40	42	46	—	50	40	12,500	2.8	
5730 77220135	-135-H *	1	20	135	69	40	42	46	—	70	40	12,500	3.1	
5730 77220165	-165-H *	1	20	165	69	40	42	46	—	70	40	12,500	3.6	
5730 77225120	-PHC25A -120-H	1	25	120	59	50	52	62	—	64	50	12,500	3.4	
5730 77225165	-165-H	1	25	165	79	50	52	62	—	80	50	12,500	4.3	
5730 77232135	-PHC32A -135-H	3	32	135	—	60	62	—	—	80	65	12,000	3.9	
5730 77232165	-165-H	3	32	165	—	60	62	—	—	80	65	12,000	4.6	

- El zanco de la herramienta de corte debe estar dentro de la tolerancia especificada a continuación; Diámetro del zanco menor de 6 mm : Dentro de tolerancia h6, Diámetro del zanco de 6 mm o mayor: Dentro de la tolerancia h7, tolerancia h6 ó 0/-0.01mm es la tolerancia recomendada en las herramientas de corte al usar nuestros productos.
- PHC12A y PHC20A cuentan con orificios de acople para perno, para las boquillas que tienen incluido el perno de retención
- La velocidad permitida se ve afectada por la rigidez del husillo de la máquina y el balance de la herramienta de corte. Incrementar gradualmente de una velocidad lenta, hasta llegar a la velocidad adecuada.
- * Es posible utilizar boquilla PHS.

- Cutting tool shank must be within tolerances specified next; Shank diameter less than 6mm : Within h6 tolerance, Shank diameter 6mm and over : Within h7 tolerance, h6 or 0/-0.01 tolerance is recommended when newly making a cutting tool.
- PHC12A and PHC20A have pin holes for collet with stopper pin on its body.
- Allowed speed is greatly affected by the stiffness of the machine spindle and the balance of the cutting tool. Gradually increase from a low speed, and use at the proper speed.
- * Compatible for PHS collet use.

Ejemplo para Ordenar - Ordering Example

Ejemplo para Ordenar - Ordering Example

HSK50A-PHC 03 A- 80 HSK100A-PHC 12 A- 135 - H

Interfaz y diámetro de husillo

Diámetro Interno

Longitud de proyección

Interfaz y diámetro de husillo

Diámetro Interno

Longitud de proyección

Barreno de cambio manual

Boquilla PHS
PHS Collet

Llave Allen
Hex. Wrench

Pág. 114

Pág. 99

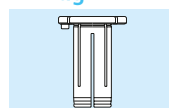

PHC · SA-C

Nuevo

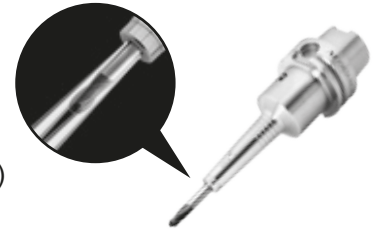

Portaherramienta Hidráulico Delgado "Blaster" (Para refrigeración por los costados)

Slim Hydro Chuck Blaster (For side through coolant)

- La opción perfecta para trabajos en espacios reducidos, tal como acabados en fresado, barrenado y rimado en máquinas de 5-ejes.
- Perfect choice for tight space applications, such as endmill finishing, drilling and reaming on 5-axis machines.

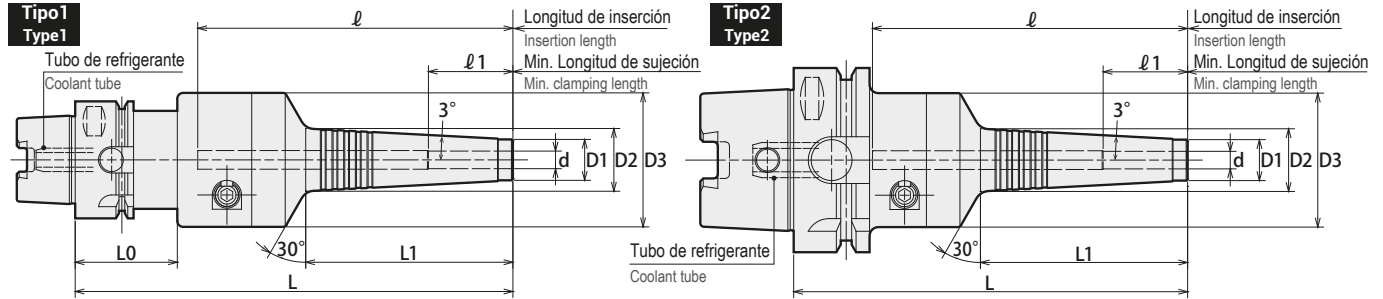

Código Code	Modelo Model	Type	d	L	L1	D1	D2	D3	L0	ℓ	$\ell 1$	Max min ⁻¹	kg	Llave Allen (Opcional) Wrench (Option)
5770 13203100	HSK40A -PHC03SA -100 -C	1	3	100	30	12	15.2	46	35	79	18	30,000	0.4	L-4T
5770 13204100	-PHC04SA -100 -C	1	4	100	30	12	15.2	46	35	79	24	30,000	0.4	
5770 13206150	-PHC06SA -150 -C	1	6	150	71	14	21.5	46	35	129	29	17,000	0.9	
5770 13208150	-PHC08SA -150 -C	1	8	150	72	16	23.6	46	35	129	29	16,000	1.0	
5770 13210150	-PHC10SA -150 -C	1	10	150	72	18	25.6	46	35	129	40	16,000	1.0	
5770 13212150	-PHC12SA -150 -C	1	12	150	73	20	27.7	46	35	129	40	15,000	1.0	
5770 14203150	HSK50A -PHC03SA -150 -C	1	3	150	71	12	19.5	46	42	124	18	18,000	0.9	L-4T
5770 14204150	-PHC04SA -150 -C	1	4	150	71	12	19.5	46	42	124	24	18,000	0.9	
5770 14206150	-PHC06SA -150 -C	1	6	150	71	14	21.5	46	42	129	29	18,000	1.1	
5770 14208150	-PHC08SA -150 -C	1	8	150	72	16	23.6	46	42	129	29	18,000	1.1	
5770 14210150	-PHC10SA -150 -C	1	10	150	72	18	25.6	46	42	129	40	18,000	1.2	
5770 14212150	-PHC12SA -150 -C	1	12	150	73	20	27.7	46	42	129	40	16,000	1.2	
5770 75203135	HSK63A -PHC03SA -135 -C	2	3	135	71	12	19.5	46	-	108	18	20,500	1.2	L-4T
5770 75204080	-PHC04SA -80 -C	2	4	80	19	12	14.0	46	-	53	24	20,500	0.8	
5770 75204135	-135 -C	2	4	135	71	12	19.5	46	-	108	24	20,500	1.2	
5770 75206135	-PHC06SA -135 -C	2	6	135	71	14	21.5	46	-	108	29	20,500	1.2	
5770 75208135	-PHC08SA -135 -C	2	8	135	72	16	23.6	46	-	108	29	20,500	1.2	
5770 75210135	-PHC10SA -135 -C	2	10	135	72	18	25.6	46	-	108	40	20,000	1.3	
5770 75212135	-PHC12SA -135 -C	2	12	135	73	20	27.7	46	-	108	40	20,000	1.3	
5770 75212180	-180 -C	2	12	180	119	20	32.5	46	-	153	40	10,000	1.5	L-6T
5770 75216135	-PHC16SA -135 -C	2	16	135	72	24	31.6	52.5	-	90	40	20,000	1.4	
5770 75216180	-180 -C	2	16	180	119	24	36.5	52.5	-	135	40	10,000	1.7	
5770 75220150	-PHC20SA -150 -C	1	20	150	63	29	35.7	62	42	85	40	19,000	2.2	
5770 75220195	-195 -C	1	20	195	109	29	40.5	62	42	130	40	10,000	2.5	
5770 75225150	-PHC25SA -150 -C	1	25	150	65	38	44.9	62	42	85	50	16,000	2.2	
5770 75225195	-195 -C	1	25	195	112	38	49.8	62	42	130	50	10,000	2.6	
5770 77206150	HSK100A -PHC06SA -150 -C	2	6	150	71	14	21.5	46	-	123	29	12,500	2.7	L-4T
5770 77206195	-195 -C	2	6	195	118	14	26.4	46	-	161	29	9,000	2.8	
5770 77208150	-PHC08SA -150 -C	2	8	150	72	16	23.6	46	-	123	29	12,500	2.7	
5770 77208195	-195 -C	2	8	195	118	16	28.4	46	-	161	29	9,000	2.9	
5770 77210150	-PHC10SA -150 -C	2	10	150	72	18	25.6	46	-	123	40	12,500	2.7	
5770 77210195	-195 -C	2	10	195	119	18	30.5	46	-	168	40	9,000	2.9	
5770 77212150	-PHC12SA -150 -C	2	12	150	73	20	27.7	46	-	123	40	12,500	2.8	
5770 77212195	-195 -C	2	12	195	119	20	32.5	46	-	168	40	9,000	3.0	
5770 77216150	-PHC16SA -150 -C	2	16	150	72	24	31.6	52.5	-	90	40	12,500	3.1	L-6T
5770 77216195	-195 -C	2	16	195	119	24	36.5	52.5	-	135	40	10,000	3.3	
5770 77220150	-PHC20SA -150 -C	2	20	150	63	29	35.7	62	-	85	40	12,500	3.6	
5770 77220195	-195 -C	2	20	195	109	29	40.5	62	-	130	40	11,000	3.8	
5770 77225150	-PHC25SA -150 -C	2	25	150	65	38	44.9	62	-	85	50	12,500	3.6	
5770 77225195	-195 -C	2	25	195	112	38	49.8	62	-	130	50	11,000	4.0	

HSK63A, HSK100A cuentan con barrenado de cambio manual en el zanco.

1. La tolerancia del diámetro de zanco de la herramienta debe estar dentro de h6.
2. La velocidad permitida varía mucho según la rigidez del husillo en la máquina y del balance de la herramienta de corte. Aumente gradualmente la velocidad a partir de la baja y úselo en la velocidad adecuada.

HSK63A, HSK100A have manual clamp holes in the shank.

1. Tool shank diameter tolerance must be within h6.
2. Permissible speed is greatly affected by the stiffness of the machine spindle and the balance of the cutting tool. Gradually increase from a low speed, and use at the proper speed.

Ejemplo para Ordenar - Ordering Example

HSK63A - PHC 12 SA - 135 - C

Interfaz y diámetro de husillo
Shank size

Diámetro Interior
I.D.

Longitud de proyección
Projection length

Llave Allen Hex. wrench

Pág. 99



Tornillo de retención Preset Screw

Pág. 327

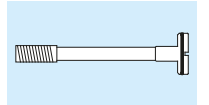

HSK-A

BT
CAT
AHO
HSK-AE/FC
HSK-T
C
UTS
Máquinas Especializadas
Specialized Machine
Equipo Relacionado
Related Equipment
Taladro de Biseado & de Casquillo
Bush & Chamfering Drill

Milling Chuck

Collet Holder

"R" Zero Holder

Hydraulic Chuck

Shrink Fit

Tapping Chuck

Arbors

Function Holder

HSK-E

HSK-F

HSK-C

Dimensions

Pulgada a métrico → Pulgada × 25.4

Métrico a pulgada → Métrico ÷ 25.4 ó métrico por 0.03937



Tamaños especiales / personalizados bajo pedido

PHC · SA-NC



Portaherramienta Hidráulico Delgado "Blaster" (con tapa)

Slim Hydro Chuck Blaster (With cap)

- La opción perfecta para trabajos en espacios reducidos, tales como acabados en fresado, barrenado y rimado en máquinas de 5-ejes.
- Perfect choice for tight space applications, such as endmill finishing, drilling and reaming on 5-axis machines.

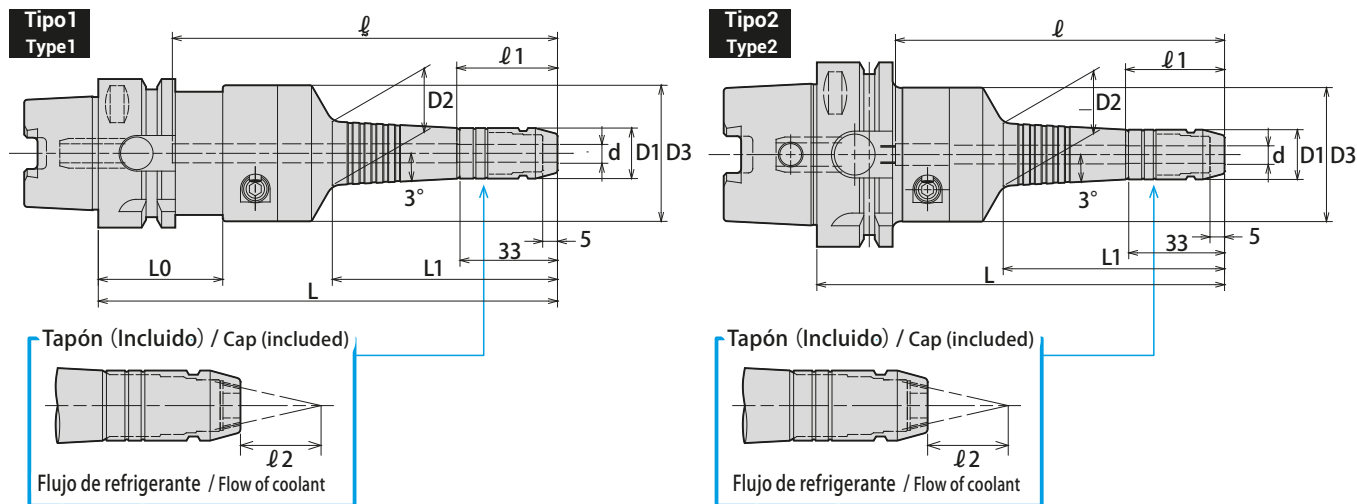

Código Code	Modelo Model	Tipo Type	d	L	L1	D1	D2	D3	L0	ℓ	ℓ1	ℓ2	Max min ⁻¹	Kg	Llave Allen (Opción Wrench)(Option)
5770 13506155	HSK40A -PHC06SA -155-NC	1	6	155	76	17	21.5	46	35	134	34	30	17,000	0.9	L-4T
5770 13508155	-PHC08SA -155-NC	1	8	155	77	19	23.6	46	35	134	34	40	16,000	1.0	
5770 13510155	-PHC10SA -155-NC	1	10	155	77	21	25.6	46	35	134	45	50	16,000	1.0	
5770 13512155	-PHC12SA -155-NC	1	12	155	78	23	27.7	46	35	134	45	60	15,000	1.0	
5770 14504155	HSK50A -PHC04SA -155-NC	1	4	155	76	15	19.5	46	42	130	29	20	18,000	0.9	L-4T
5770 14506155	-PHC06SA -155-NC	1	6	155	76	17	21.5	46	42	130	34	30	18,000	1.1	
5770 14508155	-PHC08SA -155-NC	1	8	155	77	19	23.6	46	42	130	34	40	18,000	1.1	
5770 14510155	-PHC10SA -155-NC	1	10	155	77	21	25.6	46	42	130	45	50	18,000	1.2	
5770 14512155	-PHC12SA -155-NC	1	12	155	78	23	27.7	46	42	130	45	60	16,000	1.2	L-4T
5770 75504140	HSK63A -PHC04SA -140-NC	2	4	140	76	15	19.5	46	—	113	29	20	20,500	1.2	
5770 75506140	-PHC06SA -140-NC	2	6	140	76	17	21.5	46	—	113	34	30	20,500	1.2	
5770 75508140	-PHC08SA -140-NC	2	8	140	77	19	23.6	46	—	113	34	40	20,500	1.2	
5770 75510140	-PHC10SA -140-NC	2	10	140	77	21	25.6	46	—	113	45	50	20,000	1.3	L-4T
5770 75512140	-PHC12SA -140-NC	2	12	140	78	23	27.7	46	—	113	45	60	20,000	1.3	
5770 75512185	-185-NC	2	12	185	124	23	32.5	46	—	158	45	60	10,000	1.5	
5770 77506155	HSK100A -PHC06SA -155-NC	2	6	155	76	17	21.5	46	—	121	34	30	12,500	2.7	
5770 77506200	-200-NC	2	6	200	123	17	26.4	46	—	166	34	30	9,000	2.8	L-4T
5770 77508155	-PHC08SA -155-NC	2	8	155	77	19	23.6	46	—	121	34	40	12,500	2.7	
5770 77508200	-200-NC	2	8	200	123	19	28.4	46	—	166	34	40	9,000	2.9	
5770 77510155	-PHC10SA -155-NC	2	10	155	77	21	25.6	46	—	121	45	50	12,500	2.7	
5770 77510200	-200-NC	2	10	200	124	21	30.5	46	—	166	45	50	9,000	2.9	
5770 77512155	-PHC12SA -155-NC	2	12	155	78	23	27.7	46	—	121	45	60	12,500	2.8	
5770 77512200	-200-NC	2	12	200	124	23	32.5	46	—	166	45	60	9,000	3.0	

HSK63A, HSK100A cuentan con barrenado de cambio manual en el zanco

1. Tolerancia de la herramienta de diámetro debe estar dentro de h6.
 2. La velocidad permitida se ve afectada por la rigidez en el zanco de la maquina y el balance de la herramienta de corte. Incremente la velocidad de manera gradual, utilice el portaherramienta a la velocidad apropiada.
 3. ℓ indica la dimensión al usarlo sin un tornillo de preajuste.
- HSK63A, HSK100A have manual clamp holes in the shank.
1. Tool shank diameter tolerance must be within h6.
 2. Permissible speed is greatly affected by the stiffness of the machine spindle and the balance of the cutting tool. Gradually increase from a low speed, and use at the proper speed.
 3. ℓ indicates dimension when using without a preset screw.

Ejemplo para Ordenar - Ordering Example

HSK63A - PHC 12 SA - 140 - NC

Interfaz y diámetro de husillo Shank size
 Diámetro Interior I.D.
 Longitud de proyección Projection length

Llave Allen Hex. wrench Pág. 99	Tornillo de preajuste Preset Screw Pág. 327	Tapón Cap Pág. 117

PHC · SA Nuevo



Portaherramienta Hidráulico Delgado "Blaster"

Slim Hydro Chuck Blaster

- La opción perfecta para trabajos en espacios reducidos, tales como acabados en fresado, barrenado y rimado en máquinas de 5-ejes.
- Perfect choice for tight space applications, such as endmill finishing, drilling and reaming on 5-axis machines.

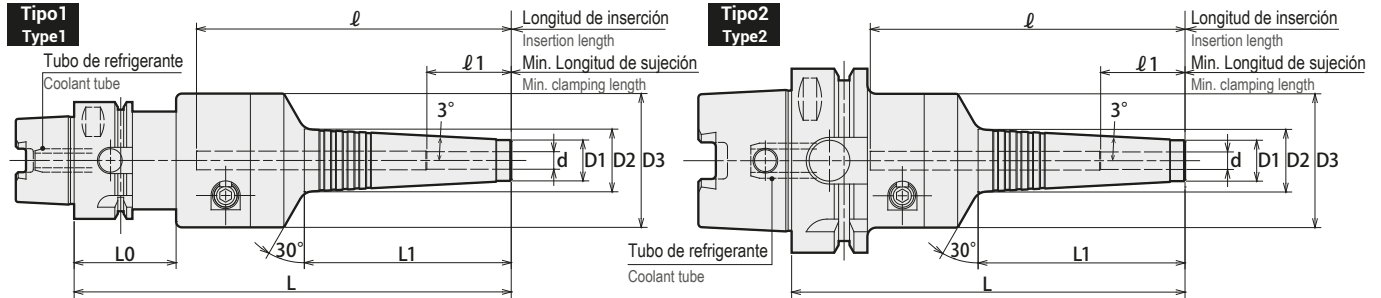

Código Code	Modelo Model	Tipo Type	d	L	L1	D1	D2	D3	L0	ℓ	ℓ1	Max min ⁻¹	Kg	Llave Allen (Opción) Wrench (Option)
5750 13203090	HSK40A -PHC03SA -90	1	3	90	19	11	13.0	46	35	69	18	30,000	0.4	L-4T
5750 13203100	-100	1	3	100	30	11	14.2	46	35	79	18	30,000	0.4	
5750 13203145	-145	1	3	145	71	11	18.5	46	35	124	18	17,000	0.7	
5750 13204090	-PHC04SA -90	1	4	90	19	11	13.0	46	35	69	24	30,000	0.4	
5750 13204100	-100	1	4	100	30	11	14.2	46	35	79	24	30,000	0.4	
5750 13204145	-145	1	4	145	71	11	18.5	46	35	124	24	17,000	0.7	
5750 13206105	-PHC06SA -105	1	6	105	26	13	15.8	46	35	84	29	28,000	0.8	
5750 13206150	-150	1	6	150	71	13	20.5	46	35	129	29	17,000	0.9	
5750 13206165	-165	1	6	165	87	13	22.2	46	35	144	29	12,000	1.0	
5750 13206180	-180	1	6	180	102	13	23.7	46	35	159	29	10,000	1.0	
5750 13207105	-PHC07SA -105	1	7	105	26	14	16.8	46	35	84	29	27,000	0.8	
5750 13207150	-150	1	7	150	71	14	21.5	46	35	129	29	16,000	1.0	
5750 13207165	-165	1	7	165	87	14	23.2	46	35	144	29	12,000	1.0	
5750 13207180	-180	1	7	180	102	14	24.7	46	35	159	29	10,000	1.1	
5750 13208105	-PHC08SA -105	1	8	105	27	15	17.9	46	35	84	29	27,000	0.8	
5750 13208150	-150	1	8	150	72	15	22.6	46	35	129	29	16,000	1.0	
5750 13208165	-165	1	8	165	87	15	24.2	46	35	144	29	12,000	1.0	
5750 13208180	-180	1	8	180	103	15	25.8	46	35	159	29	10,000	1.1	
5750 13209120	-PHC09SA -120	1	9	120	42	16	20.5	46	35	99	40	26,000	0.8	
5750 13209150	-150	1	9	150	72	16	23.6	46	35	129	40	16,000	1.0	
5750 13209165	-165	1	9	165	87	16	25.2	46	35	144	40	12,000	1.0	
5750 13209180	-180	1	9	180	103	16	26.8	46	35	159	40	10,000	1.1	
5750 13210120	-PHC10SA -120	1	10	120	42	17	21.5	46	35	99	40	25,000	0.9	
5750 13210150	-150	1	10	150	72	17	24.6	46	35	129	40	16,000	1.0	
5750 13210165	-165	1	10	165	87	17	26.3	46	35	144	40	12,000	1.0	
5750 13210180	-180	1	10	180	103	17	27.8	46	35	159	40	10,000	1.1	
5750 13211120	-PHC11SA -120	1	11	120	43	18	22.6	46	35	99	40	25,000	0.8	
5750 13211150	-150	1	11	150	73	18	25.7	46	35	129	40	16,000	1.0	
5750 13211165	-165	1	11	165	88	18	27.3	46	35	144	40	12,000	1.1	
5750 13211180	-180	1	11	180	104	18	29.0	46	35	159	40	10,000	1.1	
5750 13212120	-PHC12SA -120	1	12	120	43	19	23.6	46	35	99	40	25,000	0.8	
5750 13212150	-150	1	12	150	73	19	26.7	46	35	129	40	15,000	1.0	
5750 13212165	-165	1	12	165	88	19	28.3	46	35	144	40	12,000	1.1	
5750 13212180	-180	1	12	180	104	19	30.0	46	35	159	40	10,000	1.1	
5750 14203095	HSK50A -PHC03SA -95	1	3	95	19	11	13.0	46	42	69	18	25,000	0.6	
5750 14203105	-105	1	3	105	30	11	14.2	46	42	79	18	25,000	0.6	
5750 14203150	-150	1	3	150	71	11	18.5	46	42	124	18	18,000	0.9	
5750 14204095	-PHC04SA -95	1	4	95	19	11	13.0	46	42	69	24	25,000	0.6	
5750 14204105	-105	1	4	105	30	11	14.2	46	42	79	24	25,000	0.6	
5750 14204150	-150	1	4	150	71	11	18.5	46	42	124	24	18,000	0.9	
5750 14206105	-PHC06SA -105	1	6	105	26	13	15.8	46	42	84	29	25,000	1.0	
5750 14206150	-150	1	6	150	71	13	20.5	46	42	129	29	18,000	1.1	
5750 14206165	-165	1	6	165	87	13	22.2	46	42	144	29	13,000	1.1	
5750 14206180	-180	1	6	180	102	13	23.7	46	42	159	29	11,000	1.2	
5750 14207105	-PHC07SA -105	1	7	105	26	14	16.8	46	42	84	29	25,000	1.0	
5750 14207150	-150	1	7	150	71	14	21.5	46	42	129	29	18,000	1.1	
5750 14207165	-165	1	7	165	87	14	23.2	46	42	144	29	13,000	1.2	
5750 14207180	-180	1	7	180	102	14	24.7	46	42	159	29	11,000	1.2	
5750 14208105	-PHC08SA -105	1	8	105	27	15	17.9	46	42	84	29	25,000	1.0	
5750 14208150	-150	1	8	150	72	15	22.6	46	42	129	29	18,000	1.1	
5750 14208165	-165	1	8	165	87	15	24.2	46	42	144	29	13,000	1.2	
5750 14208180	-180	1	8	180	103	15	25.8	46	42	159	29	11,000	1.2	
5750 14209120	-PHC09SA -120	1	9	120	42	16	20.5	46	42	99	40	25,000	1.0	
5750 14209150	-150	1	9	150	72	16	23.6	46	42	129	40	18,000	1.1	
5750 14209165	-165	1	9	165	87	16	25.2	46	42	144	40	13,000	1.2	
5750 14209180	-180	1	9	180	103	16	26.8	46	42	159	40	11,000	1.3	
5750 14210120	-PHC10SA -120	1	10	120	42	17	21.5	46	42	99	40	25,000	1.0	
5750 14210150	-150	1	10	150	72	17	24.6	46	42	129	40	18,000	1.2	
5750 14210165	-165	1	10	165	87	17	26.3	46	42	144	40	13,000	1.2	
5750 14210180	-180	1	10	180	103	17	27.8	46	42	159	40	11,000	1.3	
5750 14211120	-PHC11SA -120	1	11	120	43	18	22.6	46	42	99	40	25,000	1.0	
5750 14211150	-150	1	11	150	73	18	25.7	46	42	129	40	17,000	1.2	
5750 14211165	-165	1	11	165	88	18	27.3	46	42	144	40	13,000	1.2	
5750 14211180	-180	1	11	180	104	18	29.0	46	42	159	40	11,000	1.3	
5750 14212120	-PHC12SA -120	1	12	120	43	19	23.6	46	42	99	40	25,000	1.0	
5750 14212150	-150	1	12	150	73	19	26.7	46	42	129	40	16,000	1.2	
5750 14212165	-165	1	12	165	88	19	28.3	46	42	144	40	13,000	1.2	
5750 14212180	-180	1	12	180	104	19	30.0	46	42	159	40	10,000	1.3	
5750 *5203080	HSK63A -PHC03SA -80-H	2	3	80	19	11	13.0	46	-	53	18	20,500	0.8	
5750 *5203090	-90-H	2	3	90	30	11	14.2	46	-	63	18	20,500	0.9	
5750 *5203135	-135-H	2	3	135	71	11	18.5	46	-	108	18	20,500	1.2	
5750 *5204080	-PHC04SA -80-H	2	4	80	19	11	13.0	46	-	53	24	20,500	0.8	
5750 *5204090	-90-H	2	4	90	30	11	14.2	46	-	63	24	20,500	0.8	
5750 *5204135	-135-H	2	4	135	71	11	18.5	46	-	108	24	20,500	1.2	

Código Code	Modelo Model	Tipo Type	d	L	L1	D1	D2	D3	L0	ℓ	ℓ1	Max min ⁻¹	Kg	Llave Allen (Opción) Wrench (Option)
7570 ※5206090	-PHC06SA -90-H	2	6	90	26	13	15.8	46	-	63	29	20,500	1.1	L-4T
7570 ※5206135	-135-H	2	6	135	71	13	20.5	46	-	108	29	20,500	1.2	
7570 ※5206150	-150-H	2	6	150	87	13	22.2	46	-	123	29	16,000	1.3	
7570 ※5206165	-165-H	2	6	165	102	13	23.7	46	-	138	29	12,000	1.3	
7570 ※5206180	-180-H	2	6	180	118	13	25.4	46	-	153	29	10,000	1.4	
7570 ※5207090	-PHC07SA -90-H	2	7	90	26	14	16.8	46	-	63	29	20,500	1.1	
7570 ※5207135	-135-H	2	7	135	71	14	21.5	46	-	108	29	20,500	1.2	
7570 ※5207150	-150-H	2	7	150	87	14	23.2	46	-	123	29	16,000	1.3	
7570 ※5207165	-165-H	2	7	165	102	14	24.7	46	-	138	29	12,000	1.3	
7570 ※5207180	-180-H	2	7	180	118	14	26.4	46	-	153	29	10,000	1.4	
7570 ※5208090	-PHC08SA -90-H	2	8	90	27	15	17.9	46	-	63	29	20,500	1.1	
7570 ※5208135	-135-H	2	8	135	72	15	22.6	46	-	108	29	20,500	1.2	
7570 ※5208150	-150-H	2	8	150	87	15	24.2	46	-	123	29	17,000	1.3	
7570 ※5208165	-165-H	2	8	165	103	15	25.8	46	-	138	29	12,000	1.3	
7570 ※5208180	-180-H	2	8	180	118	15	27.4	46	-	153	29	10,000	1.4	
7570 ※5209105	-PHC09SA -105-H	2	9	105	42	16	20.5	46	-	78	40	20,500	1.2	
7570 ※5209135	-135-H	2	9	135	72	16	23.6	46	-	108	40	20,500	1.3	
7570 ※5209150	-150-H	2	9	150	87	16	25.2	46	-	123	40	16,000	1.3	
7570 ※5209165	-165-H	2	9	165	103	16	26.8	46	-	138	40	12,000	1.4	
7570 ※5209180	-180-H	2	9	180	118	16	28.4	46	-	153	40	10,000	1.4	
7570 ※5210105	-PHC10SA -105-H	2	10	105	42	17	21.5	46	-	78	40	20,500	1.2	
7570 ※5210135	-135-H	2	10	135	72	17	24.6	46	-	108	40	20,000	1.3	
7570 ※5210150	-150-H	2	10	150	87	17	26.3	46	-	123	40	16,000	1.3	
7570 ※5210165	-165-H	2	10	165	103	17	27.8	46	-	138	40	12,000	1.4	
7570 ※5210180	-180-H	2	10	180	119	17	29.5	46	-	153	40	10,000	1.5	
7570 ※5211105	-PHC11SA -105-H	2	11	105	43	18	22.6	46	-	78	40	20,500	1.2	
7570 ※5211135	-135-H	2	11	135	73	18	25.7	46	-	108	40	20,000	1.3	
7570 ※5211150	-150-H	2	11	150	88	18	27.3	46	-	123	40	15,000	1.3	
7570 ※5211165	-165-H	2	11	165	104	18	29.0	46	-	138	40	12,000	1.4	
7570 ※5211180	-180-H	2	11	180	119	18	30.5	46	-	153	40	10,000	1.5	
7570 ※5212105	-PHC12SA -105-H	2	12	105	43	19	23.6	46	-	78	40	20,500	1.2	
7570 ※5212135	-135-H	2	12	135	73	19	26.7	46	-	108	40	20,000	1.3	
7570 ※5212150	-150-H	2	12	150	88	19	28.3	46	-	123	40	15,000	1.3	
7570 ※5212165	-165-H	2	12	165	104	19	30.0	46	-	138	40	12,000	1.4	
7570 ※5212180	-180-H	2	12	180	119	19	31.5	46	-	153	40	10,000	1.5	
7570 ※5216135	-PHC16SA -135-H	2	16	135	72	23	30.6	52.5	-	90	40	20,000	1.4	
7570 ※5216165	-165-H	2	16	165	103	23	33.8	52.5	-	120	40	12,000	1.6	
7570 ※5216180	-180-H	2	16	180	119	23	35.5	52.5	-	135	40	10,000	1.7	
7570 ※5220150	-PHC20SA -150-H	1	20	150	63	28	34.7	62	42	85	40	19,000	2.2	
7570 ※5220180	-180-H	1	20	180	93	28	37.8	62	42	115	40	12,000	2.2	
7570 ※5220195	-195-H	1	20	195	109	28	39.5	62	42	130	40	10,000	2.5	
7570 ※5225150	-PHC25SA -150-H	1	25	150	65	37	43.9	62	42	85	50	16,000	2.2	
7570 ※5225180	-180-H	1	25	180	96	37	47.1	62	42	115	50	12,000	2.5	
7570 ※5225195	-195-H	1	25	195	112	37	48.8	62	42	130	50	10,000	2.6	
7570 ※7206105	HSK100A -PHC06SA -105-H	2	6	105	26	13	15.8	46	-	71	29	12,500	2.6	
7570 ※7206150	-150-H	2	6	150	71	13	20.5	46	-	116	29	12,500	2.7	
7570 ※7206165	-165-H	2	6	165	87	13	22.2	46	-	131	29	12,500	2.7	
7570 ※7206180	-180-H	2	6	180	102	13	23.7	46	-	146	29	11,000	2.8	
7570 ※7206195	-195-H	2	6	195	118	13	25.4	46	-	161	29	9,000	2.8	
7570 ※7207105	-PHC07SA -105-H	2	7	105	26	14	16.8	46	-	71	29	12,500	2.6	
7570 ※7207150	-150-H	2	7	150	71	14	21.5	46	-	116	29	12,500	2.7	
7570 ※7207165	-165-H	2	7	165	87	14	23.2	46	-	131	29	12,500	2.8	
7570 ※7207180	-180-H	2	7	180	102	14	24.7	46	-	146	29	11,000	2.8	
7570 ※7207195	-195-H	2	7	195	118	14	26.4	46	-	161	29	9,000	2.9	
7570 ※7208105	-PHC08SA -105-H	2	8	105	27	15	17.9	46	-	71	29	12,500	2.7	
7570 ※7208150	-150-H	2	8	150	72	15	22.6	46	-	116	29	12,500	2.7	
7570 ※7208165	-165-H	2	8	165	87	15	24.2	46	-	131	29	12,500	2.8	
7570 ※7208180	-180-H	2	8	180	103	15	25.8	46	-	146	29	11,000	2.8	
7570 ※7208195	-195-H	2	8	195	118	15	27.4	46	-	161	29	9,000	2.9	
7570 ※7209150	-PHC09SA -150-H	2	9	150	72	16	23.6	46	-	116	40	12,500	2.7	
7570 ※7209165	-165-H	2	9	165	87	16	25.2	46	-	131	40	12,500	2.8	
7570 ※7209180	-180-H	2	9	180	103	16	26.8	46	-	146	40	11,000	2.8	
7570 ※7209195	-195-H	2	9	195	118	16	28.4	46	-	161	40	10,000	2.9	
7570 ※7210150	-PHC10SA -150-H	2	10	150	72	17	24.6	46	-	116	40	12,500	2.7	
7570 ※7210165	-165-H	2	10	165	87	17	26.3	46	-	131	40	12,500	2.8	
7570 ※7210180	-180-H	2	10	180	103	17	27.8	46	-	146	40	11,000	2.9	
7570 ※7210195	-195-H	2	10	195	119	17	29.5	46	-	161	40	9,000	2.9	
7570 ※7211150	-PHC11SA -150-H	2	11	150	73	18	25.7	46	-	116	40	12,500	2.8	
7570 ※7211165	-165-H	2	11	165	88	18	27.3	46	-	131	40	12,500	2.8	
7570 ※7211180	-180-H	2	11	180	104	18	29.0	46	-	146	40	11,000	2.9	
7570 ※7211195	-195-H	2	11	195	119	18	30.5	46	-	161	40	9,000	3.0	
7570 ※7212150	-PHC12SA -150-H	2	12	150	73	19	26.7	46	-	116	40	12,500	2.8	
7570 ※7212165	-165-H	2	12	165	88	19	28.3	46	-	131	40	12,500	2.8	
7570 ※7212180	-180-H	2	12	180	104	19	30.0	46	-	146	40	11,000	2.9	
7570 ※7212195	-195-H	2	12	195	119	19	31.5	46	-	161	40	9,000	3.0	
7570 ※7216150	-PHC16SA -150-H	2	16	150	72	23	30.6	52.5	-	90	40	12,500	3.1	
7570 ※7216180	-180-H	2	16	180	103	23	33.8	52.5	-	120	40	11,000	3.2	
7570 ※7216195	-195-H	2	16	195	119	23	35.5	52.5	-	135	40	10,000	3.3	
7570 ※7220150	-PHC20SA -150-H	2	20	150	63	28	34.7	62	-	85	40	12,500	3.6	
7570 ※7220180	-180-H	2	20	180	93	28	37.8	62	-	115	40	12,500	3.7	
7570 ※7220195	-195-H	2	20	195	109	28	39.5	62	-	130	40	11,000	3.8	
7570 ※7225150	-PHC25SA -150-H	2	25	150	65	37	43.9	62	-	85	50	12,500	3.6	
7570 ※7225180	-180-H	2	25	180	96	37	47.1	62	-	115	50	12,500	3.9	
7570 ※7225195	-195-H	2	25	195	112	37	48.8	62	-	130	50	11,000	4.0	

- La tolerancia del diámetro del zanco de la herramienta debe estar dentro de h6 o menor.
 - La velocidad permitida varía mucho según la rigidez del husillo en la máquina y del balance de la herramienta de corte. Aumente gradualmente la velocidad a partir de la baja y úselo en la velocidad adecuada.
- Tool shank diameter tolerance must be within h6.
 - Permissible speed is greatly affected by the stiffness of the machine spindle and the balance of the cutting tool. Gradually increase from a low speed, and use at the proper speed.

Llave Allen Hex. Wrench

Pág. 99



Tornillo de retención Preset Screw

Pág. 327

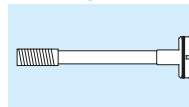

Ejemplo para Ordenar - Ordering Example

HSK63A -PHC 12 SA- 135

Interfaz y diámetro de husillo

Shank size

Diámetro Interior

I.D.

Longitud de proyección

Projection length

Ejemplo para Ordenar - Ordering Example

HSK63A -PHC 12 SA- 135 - H

Interfaz y diámetro de husillo

Shank size

Diámetro Interior

I.D.

Longitud de proyección

Projection length

Barreno de cambio manual

With manual clamping hole

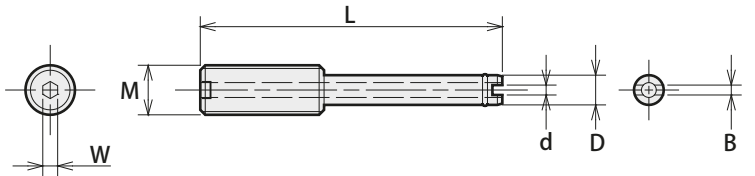
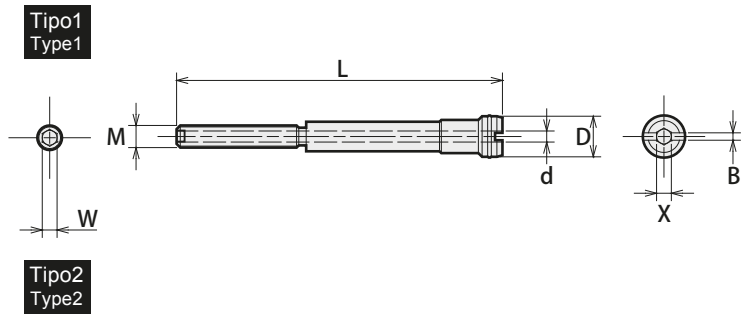
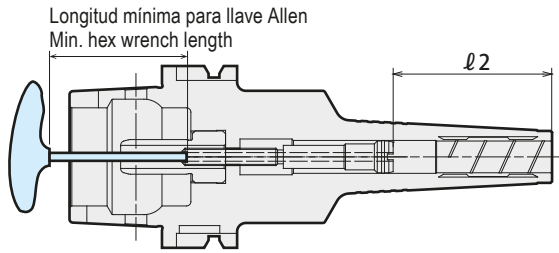

Interfaz y diámetro de husillo Shank size	Longitud mínima para llave Allen Min. hex wrench length
HSK40A	36mm
HSK50A	45mm
HSK63A	54mm
HSK100A	79mm

Tornillo de preajuste preset screw		Portaherramienta correspondiente Matched chuck	Rango de ajuste Adjustment range l2	Cantidad de ajuste Adjustment amount	Tipo Type	W	X	B	D	d	L	M
3704 00060510	PHCSA -P06 -051	HSK40A -PHC06SA -105	29 ~ 54	25	1	2.5	-	2	6	2	59	M5 P=0.8
3704 00060520	PHCSA -P06 -052	-150	29 ~ 54	25	1	2.5	-	2	6	2	104	
3704 00060530	PHCSA -P06 -053	-165	29 ~ 54	25	1	2.5	-	2	6	2	119	
3704 00060540	PHCSA -P06 -054	-180	29 ~ 54	25	1	2.5	-	2	6	2	134	
3704 00070510	PHCSA -P07 -051	-PHC07SA -105	29 ~ 54	25	1	2.5	-	2	7	2	59	
3704 00070520	PHCSA -P07 -052	-150	29 ~ 54	25	1	2.5	-	2	7	2	104	
3704 00070530	PHCSA -P07 -053	-165	29 ~ 54	25	1	2.5	-	2	7	2	119	
3704 00070540	PHCSA -P07 -054	-180	29 ~ 54	25	1	2.5	-	2	7	2	134	
3704 00080510	PHCSA -P08 -051	-PHC08SA -105	29 ~ 54	25	1	2.5	-	2	8	2	59	
3704 00080520	PHCSA -P08 -052	-150	29 ~ 54	25	1	2.5	-	2	8	2	104	
3704 00080530	PHCSA -P08 -053	-165	29 ~ 54	25	1	2.5	-	2	8	2	119	
3704 00080540	PHCSA -P08 -054	-180	29 ~ 54	25	1	2.5	-	2	8	2	134	
3704 00090510	PHCSA -P09 -051	-PHC09SA -120	40 ~ 65	25	1	2.5	-	2	9	2	63	
3704 00090520	PHCSA -P09 -052	-150	40 ~ 65	25	1	2.5	-	2	9	2	93	
3704 00090530	PHCSA -P09 -053	-165	40 ~ 65	25	1	2.5	-	2	9	2	108	
3704 00090540	PHCSA -P09 -054	-180	40 ~ 65	25	1	2.5	-	2	9	2	123	
3704 00100510	PHCSA -P10 -051	-PHC10SA -120	40 ~ 65	25	1	2.5	-	2	10	2	63	
3704 00100520	PHCSA -P10 -052	-150	40 ~ 65	25	1	2.5	-	2	10	2	93	
3704 00100530	PHCSA -P10 -053	-165	40 ~ 65	25	1	2.5	-	2	10	2	108	
3704 00100540	PHCSA -P10 -054	-180	40 ~ 65	25	1	2.5	-	2	10	2	123	
3704 00110510	PHCSA -P11 -051	-PHC11SA -120	40 ~ 65	25	1	2.5	-	2	11	2	63	
3704 00110520	PHCSA -P11 -052	-150	40 ~ 65	25	1	2.5	-	2	11	2	93	
3704 00110530	PHCSA -P11 -053	-165	40 ~ 65	25	1	2.5	-	2	11	2	108	
3704 00110540	PHCSA -P11 -054	-180	40 ~ 65	25	1	2.5	-	2	11	2	123	
3704 00120510	PHCSA -P12 -051	-PHC12SA -120	40 ~ 65	25	1	2.5	-	2	12	2	63	
3704 00120520	PHCSA -P12 -052	-150	40 ~ 65	25	1	2.5	-	2	12	2	93	
3704 00120530	PHCSA -P12 -053	-165	40 ~ 65	25	1	2.5	-	2	12	2	108	
3704 00120540	PHCSA -P12 -054	-180	40 ~ 65	25	1	2.5	-	2	12	2	123	
3704 00040121	PHCSA -P04 -012A	HSK50A -PHC03SA -95	18 ~ 44	26	2	2.5	-	1	4	2	27	
3704 00040141	PHCSA -P04 -014A	-105	18 ~ 44	26	2	2.5	-	1	4	2	37	
3704 00040161	PHCSA -P04 -016A	-150	18 ~ 44	26	2	2.5	-	1	4	2	82	
3704 00040111	PHCSA -P04 -011A	-PHC04SA -95	24 ~ 50	26	2	2.5	-	1	4	2	21	
3704 00040131	PHCSA -P04 -013A	-105	24 ~ 50	26	2	2.5	-	1	4	2	31	
3704 00040151	PHCSA -P04 -015A	-150	24 ~ 50	26	2	2.5	-	1	4	2	76	
3704 00060610	PHCSA -P06 -061	-PHC06SA -105	29 ~ 54	25	1	3	-	2	6	3	56	
3704 00060620	PHCSA -P06 -062	-150	29 ~ 54	25	1	3	-	2	6	3	101	
3704 00060630	PHCSA -P06 -063	-165	29 ~ 54	25	1	3	-	2	6	3	116	
3704 00060640	PHCSA -P06 -064	-180	29 ~ 54	25	1	3	-	2	6	3	131	
3704 00070610	PHCSA -P07 -061	-PHC07SA -105	29 ~ 54	25	1	3	-	2	7	2	56	
3704 00070620	PHCSA -P07 -062	-150	29 ~ 54	25	1	3	-	2	7	2	101	
3704 00070630	PHCSA -P07 -063	-165	29 ~ 54	25	1	3	-	2	7	2	116	
3704 00070640	PHCSA -P07 -064	-180	29 ~ 54	25	1	3	-	2	7	2	131	
3704 00080610	PHCSA -P08 -061	-PHC08SA -105	29 ~ 54	25	1	3	-	2	8	3	56	
3704 00080620	PHCSA -P08 -062	-150	29 ~ 54	25	1	3	-	2	8	3	101	
3704 00080630	PHCSA -P08 -063	-165	29 ~ 54	25	1	3	-	2	8	3	116	
3704 00080640	PHCSA -P08 -064	-180	29 ~ 54	25	1	3	-	2	8	3	131	
3704 00090610	PHCSA -P09 -061	-PHC09SA -120	40 ~ 65	25	1	3	3	2	9	3	60	
3704 00090620	PHCSA -P09 -062	-150	40 ~ 65	25	1	3	3	2	9	3	90	
3704 00090630	PHCSA -P09 -063	-165	40 ~ 65	25	1	3	3	2	9	3	105	
3704 00090640	PHCSA -P09 -064	-180	40 ~ 65	25	1	3	3	2	9	3	120	
3704 00100610	PHCSA -P10 -061	-PHC10SA -120	40 ~ 65	25	1	3	3	2	10	3	60	
3704 00100620	PHCSA -P10 -062	-150	40 ~ 65	25	1	3	3	2	10	3	90	
3704 00100630	PHCSA -P10 -063	-165	40 ~ 65	25	1	3	3	2	10	3	105	
3704 00100640	PHCSA -P10 -064	-180	40 ~ 65	25	1	3	3	2	10	3	120	
3704 00110610	PHCSA -P11 -061	-PHC11SA -120	40 ~ 65	25	1	3	3	2	11	3	60	
3704 00110620	PHCSA -P11 -062	-150	40 ~ 65	25	1	3	3	2	11	3	90	
3704 00110630	PHCSA -P11 -063	-165	40 ~ 65	25	1	3	3	2	11	3	105	
3704 00110640	PHCSA -P11 -064	-180	40 ~ 65	25	1	3	3	2	11	3	120	
3704 00120610	PHCSA -P12 -061	-PHC12SA -120	40 ~ 65	25	1	3	3	2	12	3	60	
3704 00120620	PHCSA -P12 -062	-150	40 ~ 65	25	1	3	3	2	12	3	90	
3704 00120630	PHCSA -P12 -063	-165	40 ~ 65	25	1	3	3	2	12	3	105	
3704 00120640	PHCSA -P12 -064	-180	40 ~ 65	25	1	3	3	2	12	3	120	

Tornillo de preajuste preset screw		Portaherramienta correspondiente Matched chuck		Rango de ajuste Adjustment range f2	Cantidad de ajuste Adjustment amount	Tipo Type	W	X	B	D	d	L	M
Código Code	Modelo Model												
3704 00040122	PHCSA -P04 -012B	HSK63A	-PHC03SA -75 (-H)	18 ~ 30	12	2	2.5	-	1	4	2	27	M5 P=0.8
3704 00040142	PHCSA -P04 -014B		-90 (-H)	18 ~ 30	12	2	2.5	-	1	4	2	37	
3704 00040162	PHCSA -P04 -016B		-135 (-H)	18 ~ 30	12	2	2.5	-	1	4	2	82	
3704 00040112	PHCSA -P04 -011B		-PHC04SA -75 (-H)	24 ~ 36	12	2	2.5	-	1	4	2	21	
3704 00040132	PHCSA -P04 -013B		-90 (-H)	24 ~ 36	12	2	2.5	-	1	4	2	31	
3704 00040152	PHCSA -P04 -015B		-135 (-H)	24 ~ 36	12	2	2.5	-	1	4	2	76	
3704 00060710	PHCSA -P06 -071		-PHC06SA -90 (-H)	29 ~ 59	30	1	3	-	2	6	3	38	
3704 00060730	PHCSA -P06 -073		-135 (-H)	29 ~ 59	30	1	3	-	2	6	3	83	
3704 00060740	PHCSA -P06 -074		-150 (-H)	29 ~ 59	30	1	3	-	2	6	3	98	
3704 00060760	PHCSA -P06 -076		-165 (-H)	29 ~ 59	30	1	3	-	2	6	3	113	
3704 00060770	PHCSA -P06 -077		-180 (-H)	29 ~ 59	30	1	3	-	2	6	3	128	
3704 00060710	PHCSA -P06 -071		-PHC07SA -90 (-H)	29 ~ 59	30	1	3	-	2	6	3	38	
3704 00070730	PHCSA -P07 -073		-135 (-H)	29 ~ 59	30	1	3	-	2	7	2	83	
3704 00070740	PHCSA -P07 -074		-150 (-H)	29 ~ 59	30	1	3	-	2	7	2	98	
3704 00070760	PHCSA -P07 -076		-165 (-H)	29 ~ 59	30	1	3	-	2	7	2	113	
3704 00070770	PHCSA -P07 -077		-180 (-H)	29 ~ 59	30	1	3	-	2	7	2	128	
3704 00060710	PHCSA -P06 -071		-PHC08SA -90 (-H)	29 ~ 59	30	1	3	-	2	6	3	38	
3704 00080730	PHCSA -P08 -073		-135 (-H)	29 ~ 59	30	1	3	-	2	8	3	83	
3704 00080740	PHCSA -P08 -074		-150 (-H)	29 ~ 59	30	1	3	-	2	8	3	98	
3704 00080760	PHCSA -P08 -076		-165 (-H)	29 ~ 59	30	1	3	-	2	8	3	113	
3704 00080770	PHCSA -P08 -077		-180 (-H)	29 ~ 59	30	1	3	-	2	8	3	128	
3704 00090710	PHCSA -P09 -071		-PHC09SA -105 (-H)	40 ~ 64	30	1	3	3	2	9	3	42	
3704 00090720	PHCSA -P09 -072		-135 (-H)	40 ~ 69	29	1	3	3	2	9	3	73	
3704 00090740	PHCSA -P09 -074		-150 (-H)	40 ~ 69	29	1	3	3	2	9	3	88	
3704 00090750	PHCSA -P09 -075		-165 (-H)	40 ~ 69	29	1	3	3	2	9	3	103	
3704 00090770	PHCSA -P09 -077		-180 (-H)	40 ~ 61	21	1	3	3	2	9	3	126	
3704 00090710	PHCSA -P09 -071		-PHC10SA -105 (-H)	40 ~ 70	30	1	3	3	2	9	3	42	
3704 00100720	PHCSA -P10 -072		-135 (-H)	40 ~ 69	29	1	3	3	2	10	3	73	
3704 00100740	PHCSA -P10 -074		-150 (-H)	40 ~ 69	29	1	3	3	2	10	3	88	
3704 00100750	PHCSA -P10 -075		-165 (-H)	40 ~ 69	29	1	3	3	2	10	3	103	
3704 00100770	PHCSA -P10 -077		-180 (-H)	40 ~ 61	21	1	3	3	2	10	3	126	
3704 00090710	PHCSA -P09 -071		-PHC11SA -105 (-H)	40 ~ 64	30	1	3	3	2	9	3	42	
3704 00110720	PHCSA -P11 -072		-135 (-H)	40 ~ 69	29	1	3	3	2	11	3	73	
3704 00110740	PHCSA -P11 -074		-150 (-H)	40 ~ 69	29	1	3	3	2	11	3	88	
3704 00110750	PHCSA -P11 -075		-165 (-H)	40 ~ 69	29	1	3	3	2	11	3	103	
3704 00110770	PHCSA -P11 -077		-180 (-H)	40 ~ 61	21	1	3	3	2	11	3	126	
3704 00090710	PHCSA -P09 -071		-PHC12SA -105 (-H)	40 ~ 64	30	1	3	3	2	9	3	42	
3704 00120720	PHCSA -P12 -072		-135 (-H)	40 ~ 69	29	1	3	3	2	12	3	73	
3704 00120740	PHCSA -P12 -074		-150 (-H)	40 ~ 69	29	1	3	3	2	12	3	88	
3704 00120750	PHCSA -P12 -075		-165 (-H)	40 ~ 69	29	1	3	3	2	12	3	103	
3704 00120770	PHCSA -P12 -077		-180 (-H)	40 ~ 61	21	1	3	3	2	12	3	126	
3704 00160710	PHCSA -P16 -071		-PHC16SA -135 (-H)	40 ~ 85	45	1	3	3	2	16	3	55	
3704 00160720	PHCSA -P16 -072		-165 (-H)	40 ~ 80	40	1	3	3	2	16	3	85	
3704 00160730	PHCSA -P16 -073		-180 (-H)	40 ~ 80	40	1	3	3	2	16	3	100	
3704 00200710	PHCSA -P20 -071		-PHC20SA -150 (-H)	40 ~ 80	40	1	3	3	2	20	3	50	
3704 00200720	PHCSA -P20 -072		-180 (-H)	40 ~ 80	40	1	3	3	2	20	3	80	
3704 00200730	PHCSA -P20 -073		-195 (-H)	40 ~ 80	40	1	3	3	2	20	3	95	
3704 00250710	PHCSA -P25 -071		-PHC25SA -150 (-H)	50 ~ 80	30	1	3	3	2	25	3	41	
3704 00250720	PHCSA -P25 -072		-180 (-H)	50 ~ 90	40	1	3	3	2	25	3	71	
3704 00250730	PHCSA -P25 -073		-195 (-H)	50 ~ 90	40	1	3	3	2	25	3	86	
3704 00060720	PHCSA -P06 -072	HSK100A	-PHC06SA -105 (-H)	29 ~ 59	30	1	3	-	2	6	3	47	
3704 00060740	PHCSA -P06 -074		-150 (-H)	29 ~ 52	23	1	3	-	2	6	3	98	
3704 00060750	PHCSA -P06 -075		-165 (-H)	29 ~ 57	28	1	3	-	2	6	3	108	
3704 00060770	PHCSA -P06 -077		-180 (-H)	29 ~ 52	23	1	3	-	2	6	3	128	
3704 00060780	PHCSA -P06 -078		-195 (-H)	29 ~ 59	30	1	3	-	2	6	3	137	
3704 00060720	PHCSA -P06 -072		-PHC07SA -105 (-H)	29 ~ 59	30	1	3	-	2	6	3	47	
3704 00070740	PHCSA -P07 -074		-150 (-H)	29 ~ 52	23	1	3	-	2	7	2	98	
3704 00070750	PHCSA -P07 -075		-165 (-H)	29 ~ 57	28	1	3	-	2	7	2	108	
3704 00070770	PHCSA -P07 -077		-180 (-H)	29 ~ 52	23	1	3	-	2	7	2	128	
3704 00070780	PHCSA -P07 -078		-195 (-H)	29 ~ 59	30	1	3	-	2	7	2	137	
3704 00060720	PHCSA -P06 -072		-PHC08SA -105 (-H)	29 ~ 58	29	1	3	-	2	6	3	47	
3704 00080740	PHCSA -P08 -074		-150 (-H)	29 ~ 52	23	1	3	-	2	8	3	98	
3704 00080750	PHCSA -P08 -075		-165 (-H)	29 ~ 57	28	1	3	-	2	8	3	108	
3704 00080770	PHCSA -P08 -077		-180 (-H)	29 ~ 52	23	1	3	-	2	8	3	128	
3704 00080780	PHCSA -P08 -078		-195 (-H)	29 ~ 58	29	1	3	-	2	8	3	137	
3704 00090730	PHCSA -P09 -073		-PHC09SA -150 (-H)	40 ~ 70	30	1	3	3	2	9	3	81	
3704 00090750	PHCSA -P09 -075		-165 (-H)	40 ~ 62	22	1	3	3	2	9	3	103	
3704 00090760	PHCSA -P09 -076		-180 (-H)	40 ~ 69	29	1	3	3	2	9	3	111	
3704 00090770	PHCSA -P09 -077		-195 (-H)	40 ~ 69	29	1	3	3	2	9	3	126	
3704 00100730	PHCSA -P10 -073		-PHC10SA -150 (-H)	40 ~ 70	30	1	3	3	2	10	3	81	
3704 00100750	PHCSA -P10 -075		-165 (-H)	40 ~ 63	23	1	3	3	2	10	3	103	
3704 00100760	PHCSA -P10 -076		-180 (-H)	40 ~ 70	30	1	3	3	2	10	3	111	
3704 00100770	PHCSA -P10 -077		-195 (-H)	40 ~ 70	30	1	3	3	2	10	3	126	
3704 00110730	PHCSA -P11 -073		-PHC11SA -150 (-H)	40 ~ 70	30	1	3	3	2	11	3	81	
3704 00110750	PHCSA -P11 -075		-165 (-H)	40 ~ 63	23	1	3	3	2	11	3	103	
3704 00110760	PHCSA -P11 -076		-180 (-H)	40 ~ 70	30	1	3	3	2	11	3	111	
3704 00110770	PHCSA -P11 -077		-195 (-H)	40 ~ 70	30	1	3	3	2	11	3	126	
3704 00120730	PHCSA -P12 -073		-PHC12SA -150 (-H)	40 ~ 70	30	1	3	3	2	12	3	81	
3704 00120750	PHCSA -P12 -075		-165 (-H)	40 ~ 63	23	1	3	3	2	12	3	103	
3704 00120760	PHCSA -P12 -076		-180 (-H)	40 ~ 70	30	1	3	3	2	12	3	111	
3704 00120770	PHCSA -P12 -077		-195 (-H)	40 ~ 70	30	1	3	3	2	12	3	126	
3704 00160710	PHCSA -P16 -071		-PHC16SA -150 (-H)	40 ~ 85	45	1	3	3	2	16	3	55	
3704 00160720	PHCSA -P16 -072		-180 (-H)	40 ~ 80	40	1	3	3	2	16	3	85	
3704 00160730	PHCSA -P16 -073		-195 (-H)	40 ~ 80	40	1	3	3	2	16	3	100	
3704 00200710	PHCSA -P20 -071		-PHC20SA -150 (-H)	40 ~ 80	40	1	3	3	2	20	3	50	
3704 00200720	PHCSA -P20 -072		-180 (-H)	40 ~ 80	40	1	3	3	2	20	3	80	
3704 00200730	PHCSA -P20 -073		-195 (-H)	40 ~ 80	40	1	3	3	2	20	3	95	
3704 00250710	PHCSA -P25 -071		-PHC25SA -150 (-H)	50 ~ 80	30	1	3	3	2	25	3	41	
3704 00250720	PHCSA -P25 -072		-180 (-H)	50 ~ 90	40	1	3	3	2	25	3	71	
3704 00250730	PHCSA -P25 -073		-195 (-H)	50 ~ 90	40	1	3	3	2	25	3	86	

PHC-H

Hydro Chuck Ω

- Hydro Chuck de alta rigidez es la mejor opción para maquinados pesados.
- High Rigidity Hydro Chuck is the best holder for high efficiency rough machining.

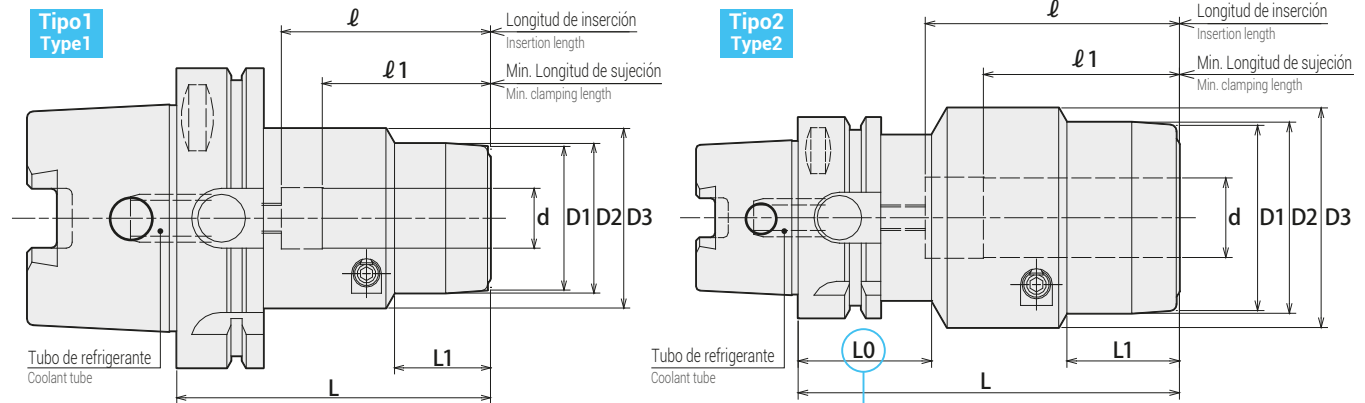

⚠ Precaución/Caution
 Tenga precaución, revise que no tenga interferencia el brazo A.T.C. (automatic tool changer) y el cartucho de herramientas.
 Take caution against A.T.C. arm and tool magazine interference.

Código Code	Modelo Model	Tipo Type	d	L	L1	D1	D2	D3	L0	ℓ	ℓ1	Max. min ⁻¹	kg	Llave Allen (Opcional) Hex. Wrench (Optional)
5330 75016080	HSK63A -PHC16H - 80 -H	2	16	80	21	—	44	56	42	51	45	20,000	1.4	L-4T
5330 75020105	-PHC20H - 105 -H	2	20	105	32	48	50	60	42	75	50	20,000	1.8	L-4T
5330 75025105	-PHC25H - 105 -H	2	25	105	35	58	60	69	42	75	55	16,000	2.1	L-5T
5330 75032105	-PHC32H - 105 -H	2	32	105	37	63	65	75	42	78	65	12,000	2.1	L-5T
5330 75032135	- 135 -H	2	32	135	47	63	65	75	42	105	65	12,000	2.9	L-5T
5330 77016105	HSK100A -PHC16H - 105 -H	1	16	105	27	—	44	56	—	70	45	12,500	3.1	L-4T
5330 77020105	-PHC20H - 105 -H	1	20	105	32	48	50	60	—	70	50	12,500	3.2	L-4T
5330 77025105	-PHC25H - 105 -H	1	25	105	35	58	60	69	—	70	55	12,500	3.6	L-5T
5330 77025135	- 135 -H	1	25	135	35	58	60	69	—	100	55	12,500	4.3	L-5T
5330 77032110	-PHC32H - 110 -H	1	32	110	47	63	65	75	—	78	65	12,000	3.8	L-5T
5330 77032135	- 135 -H	1	32	135	47	63	65	75	—	100	65	12,000	4.5	L-5T
5330 77042135	-PHC42H - 135 -H	2	42	135	52	78	80	90	—	110	73	10,000	5.4	L-6T

1. Tolerancia de la herramienta de diámetro debe estar dentro de h7. Es recomendada una tolerancia h6 o 0/-0.01 para nuevas herramientas de corte.
 2. PHC20H y PHC32H cuentan con orificios con clavija de torque, para las boquillas que tienen incluida la clavija de torque opresor.
 3. La velocidad permitida se ve afectada por la rigidez del husillo de la máquina y el balance de la herramienta de corte. Incrementar gradualmente de una velocidad lenta, hasta llegar a la velocidad adecuada.
1. Tool shank diameter tolerance must be within h7. h6 or 0/-0.01 tolerance is recommended when newly making a cutting tool.
 2. PHC20H and PHC32H have pin holes for collet with stopper pin on its body.
 3. Allowed speed is greatly affected by the stiffness of the machine spindle and the balance of the cutting tool. Gradually increase from a low speed, and use at the proper speed.

Ejemplo para Ordenar - Ordering Example

Con barreno de cambio manual (HSK63A~HSK100A)

With manual clamp holes (HSK63A~HSK100A)

HSK63A -PHC 16 H - 80 - H

Interfaz y diámetro de husillo Shank size
 Diámetro Interior I.D.
 Longitud de Proyección Projection length
 Barreno de cambio manual Manual clamp hole

Boquilla PHS-H PHS-H Collet
 Tomillo de Retención Stopper Bolt

Pág. 123

Pág. 123

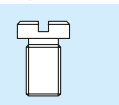
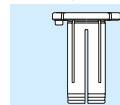

SRK

Shrink Fit (Heavy Type)

- El método de contracción coloca firmemente a una herramienta de corte al calentar y enfriar el portaherramienta. Alta precisión y una gran fuerza de sujeción. (Tipo pesado)
- Shrinkage method sets a cutting tool firmly by heating and cooling the chuck. High precision and strong Clamping force. (Heavy Type)

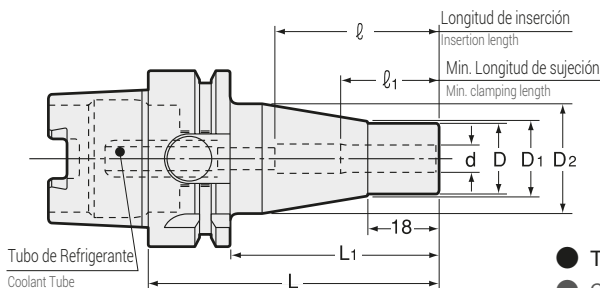

- Tubo de refrigerante incluido.
- Coolant tube is included.

Medidas Métricas - Metric Sizes

Unidad : Métrico
Unit : Metric

Código Code	Modelo Model	d	L	L1	D	D1	D2	ℓ1	ℓ	kg
5640 13106080	HSK40A -SRK6A -80	6	80	60	16	17	30	26	26 ~ 36	0.4
5640 13108080	HSK40A -SRK8A -80	8	80	60	19	20	32	26	26 ~ 50	0.4
5640 13010080	HSK40A -SRK10A -80	10	80	60	24	25	34	32	32 ~ 50	0.6
5640 13012090	HSK40A -SRK12A -90	12	90	70	28	29	34	37	37 ~ 70	0.6
5640 13016090	HSK40A -SRK16A -90	16	90	70	32	33	34	40	40 ~ 70	0.7
5640 14106080	HSK50A -SRK6A -80	6	80	54	16	17	30	26	26 ~ 36	0.7
5640 14108080	HSK50A -SRK8A -80	8	80	54	19	20	32	26	26 ~ 50	0.7
5640 14010085	HSK50A -SRK10A -85	10	85	59	24	25	34	32	32 ~ 50	0.8
5640 14012090	HSK50A -SRK12A -90	12	90	64	28	29	34	37	37 ~ 65	0.8
5640 14016095	HSK50A -SRK16A -95	16	95	69	32	33	34	40	40 ~ 70	0.8
5640 14020100	HSK50A -SRK20A -100	20	100	74	36	37	42	42	42 ~ 75	1.0
5640 75006080	HSK63A -SRK6A -80-H	6	80	54	16	17	30	26	26 ~ 36	0.9
5640 75008080	HSK63A -SRK8A -80-H	8	80	54	19	20	32	26	26 ~ 50	0.9
5640 75010085	HSK63A -SRK10A -85-H	10	85	59	24	25	34	32	32 ~ 50	1.0
5640 75012090	HSK63A -SRK12A -90-H	12	90	64	28	29	34	37	37 ~ 63	1.0
5640 75016095	HSK63A -SRK16A -95-H	16	95	69	32	33	34	40	40 ~ 65	1.1
5640 75020100	HSK63A -SRK20A -100-H	20	100	74	36	37	42	42	42 ~ 72	1.3
5640 75025115	HSK63A -SRK25A -115-H	25	115	89	46	47	53	48	48 ~ 89	1.8
5640 77006085	HSK100A -SRK6A -85-H	6	85	56	16	17	30	26	26 ~ 36	1.2
5640 77008085	HSK100A -SRK8A -85-H	8	85	56	19	20	32	26	26 ~ 50	1.2
5640 77010090	HSK100A -SRK10A -90-H	10	90	61	24	25	34	32	32 ~ 50	1.3
5640 77012095	HSK100A -SRK12A -95-H	12	95	66	28	29	34	37	37 ~ 62	1.3
5640 77016100	HSK100A -SRK16A -100-H	16	100	71	32	33	34	40	40 ~ 65	1.4
5640 77020105	HSK100A -SRK20A -105-H	20	105	76	36	37	42	42	42 ~ 70	1.7
5640 77025115	HSK100A -SRK25A -115-H	25	115	86	46	47	53	48	48 ~ 80	2.2
5640 77032120	HSK100A -SRK32A -120-H	32	120	91	56	57	70	51	51 ~ 85	3.0

Siempre use herramientas de zanco de carburo con tolerancia de h6.
Always use carbide shank tools with h6 tolerance.

Tabla de dispositivos térmicos Heating device chart

Dispositivo térmico Heating device	Portaherramienta - chuck	
	SRK6A, SRK8A	SRK10A~SRK32A
ISG3400	Sí / Yes	Sí / Yes *
SRK-HA1, HB2	No	Sí / Yes

*Se necesita de una bobina inductora especial. Diríjase a la pág. 486-487.
*Special induction coil is needed. Refer to P.486-487.

Ejemplo para Ordenar - Ordering Example

HSK63A	-	SRK	6	A	-	80	-	H
Interfaz y diámetro de husillo Shank size			Diámetro Interno I.D.			Longitud de proyección Projection length		Barreno de Cambio Manual Manual clamp hole

Ejemplo para Ordenar - Ordering Example

HSK40A	-	SRK	12	A	-	90
Interfaz y diámetro de husillo Shank size			Diámetro Interno I.D. (d)			Longitud de proyección Projection length (L)

NOTAS

SRD

Shrink Fit (DIN Standard)

- El método de contracción sujeta firmemente a una herramienta de corte al calentar y enfriar el portaherramienta. Alta precisión y mucha fuerza de fresado. (Para DIN)
- Shrinkage method clamps a cutting tool firmly by heating and cooling the chuck. High precision and strong chucking force. (DIN Type)

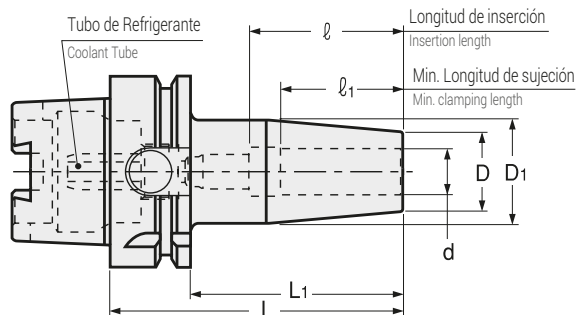

- Tubo de refrigerante incluido.
- Coolant tube is included.

Medida en Pulgadas - Inch Sizes

Unidad : Pulgadas
Unit : Inch

Código Code	Modelo Model	d	L	L1	D	D1	ℓ1	ℓ
5640 43308080	HSK40A -SRD0250 A -80	0.250	3.150	2.362	0.827	1.063	1.024	1.417
5640 43308120	-120	0.250	4.724	3.937	0.827	1.063	1.024	1.417
5640 43308160	-160	0.250	6.299	5.512	0.827	1.063	1.024	1.417
5640 43310080	HSK40A -SRD0312 A -80	0.312	3.150	2.362	0.827	1.063	1.024	1.417
5640 43310120	-120	0.312	4.724	3.937	0.827	1.063	1.024	1.969
5640 43310160	-160	0.312	6.299	5.512	0.827	1.063	1.024	1.969
5640 43312080	HSK40A -SRD0375 A -80	0.375	3.150	2.362	0.945	1.260	1.260	1.654
5640 43312120	-120	0.375	4.724	3.937	0.945	1.260	1.260	1.969
5640 43312160	-160	0.375	6.299	5.512	0.945	1.260	1.260	1.969
5640 43316090	HSK40A -SRD0500 A -90	0.500	3.543	2.756	0.945	1.260	1.457	1.850
5640 43316120	-120	0.500	4.724	3.937	0.945	1.260	1.457	2.756
5640 43316160	-160	0.500	6.299	5.512	0.945	1.260	1.457	2.756
5640 43320090	HSK40A -SRD0625 A -90	0.625	3.543	2.756	1.063	1.339	1.575	1.969
5640 43320120	-120	0.625	4.724	3.937	1.063	1.339	1.575	2.756
5640 43320160	-160	0.625	6.299	5.512	1.063	1.339	1.575	2.756
5640 75408080	HSK63A -SRD0250 A -80-H	0.250	3.150	2.126	0.827	1.063	1.024	1.417
5640 75408120	-120-H	0.250	4.724	3.701	0.827	1.063	1.024	1.417
5640 75408160	-160-H	0.250	6.299	5.276	0.827	1.063	1.024	1.417
5640 75410080	HSK63A -SRD0312 A -80-H	0.312	3.150	2.126	0.827	1.063	1.024	1.417
5640 75410120	-120-H	0.312	4.724	3.701	0.827	1.063	1.024	1.969
5640 75410160	-160-H	0.312	6.299	5.276	0.827	1.063	1.024	1.969
5640 75412085	HSK63A -SRD0375 A -85-H	0.375	3.346	2.323	0.945	1.260	1.260	1.654
5640 75412120	-120-H	0.375	4.724	3.701	0.945	1.260	1.260	1.969
5640 75412160	-160-H	0.375	6.299	5.276	0.945	1.260	1.260	1.969
5640 75416090	HSK63A -SRD0500 A -90-H	0.500	3.543	2.520	0.945	1.260	1.457	1.850
5640 75416120	-120-H	0.500	4.724	3.701	0.945	1.260	1.457	2.756
5640 75416160	-160-H	0.500	6.299	5.276	0.945	1.260	1.457	2.756
5640 75420095	HSK63A -SRD0625 A -95-H	0.625	3.740	2.717	1.063	1.339	1.575	1.969
5640 75420120	-120-H	0.625	4.724	3.701	1.063	1.339	1.575	2.756
5640 75420160	-160-H	0.625	6.299	5.276	1.063	1.339	1.575	3.150
5640 75424095	HSK63A -SRD0750 A -95-H	0.750	3.740	2.717	1.299	1.654	1.575	1.969
5640 75424120	-120-H	0.750	4.724	3.701	1.299	1.654	1.575	2.756
5640 75424160	-160-H	0.750	6.299	5.276	1.299	1.654	1.575	3.150
5640 75428100	HSK63A -SRD0875 A -100-H	0.875	3.937	2.913	1.299	1.654	1.654	2.047
5640 75428160	-160-H	0.875	6.299	5.276	1.299	1.654	1.654	3.583
5640 75432115	HSK63A -SRD1000 A -115-H	1.000	4.528	3.504	1.732	2.087	1.890	2.047
5640 75432160	-160-H	1.000	6.299	5.276	1.732	2.087	1.890	3.583
5640 75440120	HSK63A -SRD1250 A -120-H	1.250	4.724	3.701	1.732	2.087	1.890	2.441
5640 75440160	-160-H	1.250	6.299	5.276	1.732	2.087	1.890	3.819

Medida en Pulgadas - Inch Sizes

Unidad : Pulgadas
Unit : Inch

Código Code	Modelo Model	d	L	L1	D	D1	ℓ1	ℓ
5640 77408085	HSK100A -SRD0250 A -85-H	0.250	3.346	2.205	0.827	1.063	1.024	1.417
5640 77408120	-120-H	0.250	4.724	3.583	0.827	1.063	1.024	1.417
5640 77408160	-160-H	0.250	6.299	5.157	0.827	1.063	1.024	1.417
5640 77410085	HSK100A -SRD0312 A -85-H	0.312	3.346	2.205	0.827	1.063	1.024	1.417
5640 77410120	-120-H	0.312	4.724	3.583	0.827	1.063	1.024	1.969
5640 77410160	-160-H	0.312	6.299	5.157	0.827	1.063	1.024	1.969
5640 77412090	HSK100A -SRD0375 A -90-H	0.375	3.543	2.402	0.945	1.260	1.260	1.654
5640 77412120	-120-H	0.375	4.724	3.583	0.945	1.260	1.260	1.969
5640 77412160	-160-H	0.375	6.299	5.157	0.945	1.260	1.260	1.969
5640 77416095	HSK100A -SRD0500 A -95-H	0.500	3.740	2.598	0.945	1.260	1.457	1.850
5640 77416120	-120-H	0.500	4.724	3.583	0.945	1.260	1.457	2.756
5640 77416160	-160-H	0.500	6.299	5.157	0.945	1.260	1.457	2.756
5640 77420100	HSK100A -SRD0625 A -100-H	0.625	3.937	2.795	1.063	1.339	1.575	1.969
5640 77420160	-160-H	0.625	6.299	5.157	1.063	1.339	1.575	3.150
5640 77424100	HSK100A -SRD0750 A -100-H	0.750	3.937	2.795	1.299	1.654	1.575	1.969
5640 77424160	-160-H	0.750	6.299	5.157	1.299	1.654	1.575	3.150
5640 77428105	HSK100A -SRD0875 A -105-H	0.875	4.134	2.992	1.299	1.654	1.654	1.969
5640 77428160	-160-H	0.875	6.299	5.157	1.299	1.654	1.654	3.150
5640 77432115	HSK100A -SRD1000 A -115-H	1.000	4.528	3.386	1.732	2.087	1.890	2.283
5640 77432160	-160-H	1.000	6.299	5.157	1.732	2.087	1.890	3.661
5640 77440120	HSK100A -SRD1250 A -120-H	1.250	4.724	3.583	1.732	2.087	1.890	2.283
5640 77440160	-160-H	1.250	6.299	5.157	1.732	2.087	1.890	3.661
5640 77448120	HSK100A -SRD1500 A -120-H	1.500	4.724	3.583	1.732	2.087	1.890	2.283
5640 77448160	-160-H	1.500	6.299	5.157	1.732	2.087	1.890	3.661

Siempre use herramientas de zanco de carburo con un rango de tolerancia de h6.
Always use carbide shank tools with h6 tolerance.

Tabla de dispositivos térmicos Heating device chart		
Dispositivo térmico Heating device	Portaherramienta - chuck	
	SRD0250A, SRD0312A	SRD0375A~SRD1500A
ISG3400	Sí / Yes	Sí / Yes
SRK-HA1, HB2	No	Sí / Yes

Ejemplo para Ordenar - Ordering Example

HSK40A - SRD 0250 A - 120

Interfaz y diámetro de husillo Shank size	Diámetro Interno I.D. (d)	Longitud de proyección Projection length (L)
--	------------------------------	---

Ejemplo para Ordenar - Ordering Example

HSK63A - SRD 0250 A - 80 - H

Interfaz y diámetro de husillo Shank size	Diámetro Interno I.D.	Longitud de proyección Projection length	Barreno de Cambio Manual Manual clamp hole
--	--------------------------	---	---

SRD

Shrink Fit (DIN Standard)

- El método de contracción sujeta firmemente a una herramienta de corte al calentar y enfriar el portaherramienta. Alta precisión y mucha fuerza de fresado. (Para DIN)
- Shrinkage method clamps a cutting tool firmly by heating and cooling the chuck. High precision and strong chucking force. (DIN Type)

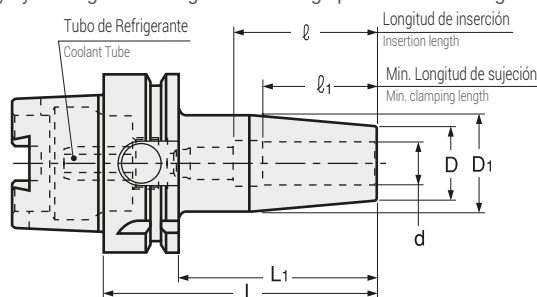

- Tubo de refrigerante incluido.
- Coolant tube is included.

Medidas Métricas - Metric Sizes

Unidad : Métrico
Unit : Metric

Código Code	Modelo Model	d	L	L1	D	D1	ℓ1	ℓ	kg
5640 41306080	HSK40A -SRD6A -80	6	80	60	21	27	26	26 ~ 36	
5640 41306120	-120	6	120	100	21	27	26	26 ~ 36	
5640 41306160	-160	6	160	140	21	27	26	26 ~ 36	
5640 41308080	HSK40A -SRD8A -80	8	80	60	21	27	26	26 ~ 36	
5640 41308120	-120	8	120	100	21	27	26	26 ~ 50	
5640 41308160	-160	8	160	140	21	27	26	26 ~ 50	
5640 41310080	HSK40A -SRD10A -80	10	80	60	24	32	32	32 ~ 42	
5640 41310120	-120	10	120	100	24	32	32	32 ~ 50	
5640 41310160	-160	10	160	140	24	32	32	32 ~ 50	
5640 41312090	HSK40A -SRD12A -90	12	90	70	24	32	37	37 ~ 47	
5640 41312120	-120	12	120	100	24	32	37	37 ~ 70	
5640 41312160	-160	12	160	140	24	32	37	37 ~ 70	
5640 41314090	HSK40A -SRD14A -90	14	90	70	27	34	37	37 ~ 47	
5640 41314120	-120	14	120	100	27	34	37	37 ~ 70	
5640 41314160	-160	14	160	140	27	34	37	37 ~ 70	
5640 41316090	HSK40A -SRD16A -90	16	90	70	27	34	40	40 ~ 50	
5640 41316120	-120	16	120	100	27	34	40	40 ~ 70	
5640 41316160	-160	16	160	140	27	34	40	40 ~ 70	
5640 75306080	HSK63A -SRD6A -80-H	6	80	54	21	27	26	26 ~ 36	
5640 75306120	-120-H	6	120	94	21	27	26	26 ~ 36	
5640 75306160	-160-H	6	160	134	21	27	26	26 ~ 36	
5640 75308080	HSK63A -SRD8A -80-H	8	80	54	21	27	26	26 ~ 36	
5640 75308120	-120-H	8	120	94	21	27	26	26 ~ 50	1.1
5640 75308160	-160-H	8	160	134	21	27	26	26 ~ 50	
5640 75310085	HSK63A -SRD10A -85-H	10	85	59	24	32	32	32 ~ 42	
5640 75310120	-120-H	10	120	94	24	32	32	32 ~ 50	1.2
5640 75310160	-160-H	10	160	134	24	32	32	32 ~ 50	
5640 75312090	HSK63A -SRD12A -90-H	12	90	64	24	32	37	37 ~ 47	
5640 75312120	-120-H	12	120	94	24	32	37	37 ~ 70	1.1
5640 75312160	-160-H	12	160	134	24	32	37	37 ~ 70	
5640 75314090	HSK63A -SRD14A -90-H	14	90	64	27	34	37	37 ~ 47	
5640 75314120	-120-H	14	120	94	27	34	37	37 ~ 70	1.2
5640 75314160	-160-H	14	160	134	27	34	37	37 ~ 70	
5640 75316095	HSK63A -SRD16A -95-H	16	95	69	27	34	40	40 ~ 50	
5640 75316120	-120-H	16	120	94	27	34	40	40 ~ 70	
5640 75316160	-160-H	16	160	134	27	34	40	40 ~ 80	1.2
5640 75318095	HSK63A -SRD18A -95-H	18	95	69	33	42	40	40 ~ 50	
5640 75318120	-120-H	18	120	94	33	42	40	40 ~ 70	
5640 75318160	-160-H	18	160	134	33	42	40	40 ~ 80	
5640 75320100	HSK63A -SRD20A -100-H	20	100	74	33	42	42	42 ~ 52	
5640 75320160	-160-H	20	160	134	33	42	42	42 ~ 91	
5640 75325115	HSK63A -SRD25A -115-H	25	115	89	44	53	48	48 ~ 62	1.8
5640 75325160	-160-H	25	160	134	44	53	48	48 ~ 97	
5640 75332120	HSK63A -SRD32A -120-H	32	120	94	44	53	52	52 ~ 62	1.7
5640 75332160	-160-H	32	160	134	44	53	52	52 ~ 97	

Medidas Métricas - Metric Sizes Unidad : Métrico
Unit : Metric

Código Code	Modelo Model	d	L	L1	D	D1	ℓ1	ℓ	kg
5640 77306085	HSK100A -SRD6A -85-H	6	85	56	21	27	26	26 ~ 36	
5640 77306120	-120-H	6	120	91	21	27	26	26 ~ 36	
5640 77306160	-160-H	6	160	131	21	27	26	26 ~ 36	
5640 77308085	HSK100A -SRD8A -85-H	8	85	56	21	27	26	26 ~ 36	
5640 77308120	-120-H	8	120	91	21	27	26	26 ~ 50	
5640 77308160	-160-H	8	160	131	21	27	26	26 ~ 50	
5640 77310090	HSK100A -SRD10A -90-H	10	90	61	24	32	32	32 ~ 42	
5640 77310120	-120-H	10	120	91	24	32	32	32 ~ 50	
5640 77310160	-160-H	10	160	131	24	32	32	32 ~ 50	
5640 77312095	HSK100A -SRD12A -95-H	12	95	66	24	32	37	37 ~ 47	
5640 77312120	-120-H	12	120	91	24	32	37	37 ~ 65	
5640 77312160	-160-H	12	160	131	24	32	37	37 ~ 70	
5640 77314095	HSK100A -SRD14A -95-H	14	95	66	27	34	37	37 ~ 47	
5640 77314120	-120-H	14	120	91	27	34	37	37 ~ 65	
5640 77314160	-160-H	14	160	131	27	34	37	37 ~ 70	
5640 77316100	HSK100A -SRD16A -100-H	16	100	71	27	34	40	40 ~ 50	
5640 77316160	-160-H	16	160	131	27	34	40	40 ~ 80	
5640 77318100	HSK100A -SRD18A -100-H	18	100	71	33	42	40	40 ~ 50	
5640 77318160	-160-H	18	160	131	33	42	40	40 ~ 80	
5640 77320105	HSK100A -SRD20A -105-H	20	105	76	33	42	42	42 ~ 52	
5640 77320160	-160-H	20	160	131	33	42	42	42 ~ 91	
5640 77325115	HSK100A -SRD25A -115-H	25	115	86	44	53	48	48 ~ 58	
5640 77325160	-160-H	25	160	131	44	53	48	48 ~ 93	
5640 77332120	HSK100A -SRD32A -120-H	32	120	91	44	53	52	52 ~ 62	
5640 77332160	-160-H	32	160	131	44	53	52	52 ~ 93	

Siempre use herramientas de zanco de carburo con un rango de tolerancia de h6.
Always use carbide shank tools with h6 tolerance.

Tabla de dispositivos térmicos Heating device chart		
Dispositivo térmico Heating device	Portaherramienta - chuck	
	SRD6A, SRD8A	SRD10A~SRD32A
ISG3400	Sí / Yes	Sí / Yes
SRK-HA1, HB2	No	Sí / Yes

Ejemplo para Ordenar - Ordering Example

HSK40A - SRD 6 A - 120		
Interfaz y diámetro de husillo Shank size	Diámetro Interno I.D. (d)	Longitud de proyección Projection length (L)

Ejemplo para Ordenar - Ordering Example

HSK63A - SRD 6 A - 80 - H			
Interfaz y diámetro de husillo Shank size	Diámetro Interno I.D.	Longitud de proyección Projection length	Barreno de Cambio Manual Manual clamp hole

- BT
- CAT
- AHO
- HSK-A/E/FC
- HSK-T
- C
- UTS
- Máquinas Especializadas
Specialized Machine
- Equipo Relacionado
Related Equipment
- Taladro de Biseado & de Casquillo
Bush & Chamfering Drill
- Milling Chuck
- Collet Holder
- "R" Zero Holder
- Hydraulic Chuck
- Srink Fit
- Tapping Chuck
- Arbors
- Function Holder
- HSK-E
- HSK-F
- HSK-C
- Dimensions



SRS

Shrink Fit (Slim Type)

- El método de contracción sujeta firmemente a una herramienta de corte al calentar y enfriar el portaherramienta. Alta precisión y mucha fuerza de fresado. (Tipo delgado)
- Shrinkage method clamps a cutting tool firmly by heating and cooling the chuck. High precision and strong Clamping force. (Slim Type)

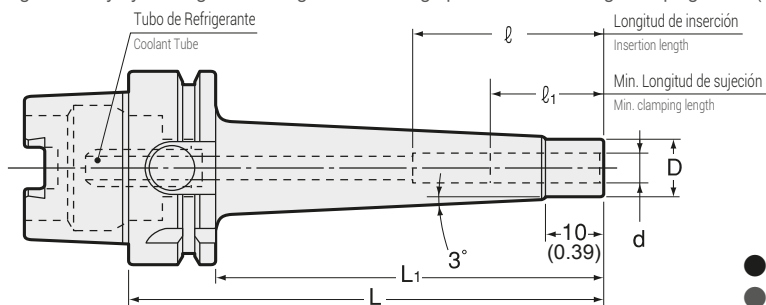

- Tubo de refrigerante incluido.
- Coolant tube is included.

Medida en Pulgadas - Inch Sizes

Unidad : Pulgadas
Unit : Inch

Código Code	Modelo Model	d (mm)	L	L1	D	l1	l
5640 33308090	HSK40A -SRS0250A -90	0.250	3.543	2.756	0.354	1.024	1.417
5640 33308120	-120	0.250	4.724	3.937	0.354	1.024	1.417
5640 33310090	HSK40A -SRS0312A -90	0.312	3.543	2.756	0.433	1.024	1.969
5640 33310120	-120	0.312	4.724	3.937	0.433	1.024	1.969
5640 33312090	HSK40A -SRS0375A -90	0.375	3.543	2.756	0.512	1.260	1.969
5640 33312120	-120	0.375	4.724	3.937	0.512	1.260	1.969
5640 33316090	HSK40A -SRS0500A -90	0.500	3.543	2.756	0.591	1.457	2.756
5640 33316120	-120	0.500	4.724	3.937	0.591	1.457	2.756
5640 33320090	HSK40A -SRS0625A -90	0.625	3.543	2.756	0.787	1.575	2.756
5640 33320120	-120	0.625	4.724	3.937	0.787	1.575	3.150
5640 75208105	HSK63A -SRS0250A -105-H	0.250	4.134	3.110	0.354	1.024	1.417
5640 75208135	-135-H	0.250	5.315	4.291	0.354	1.024	1.417
5640 75208165	-165-H	0.250	6.496	5.472	0.354	1.024	1.417
5640 75210105	HSK63A -SRS0312A -105-H	0.312	4.134	3.110	0.433	1.024	1.969
5640 75210135	-135-H	0.312	5.315	4.291	0.433	1.024	1.969
5640 75210165	-165-H	0.312	6.496	5.472	0.433	1.024	1.969
5640 75212105	HSK63A -SRS0375A -105-H	0.375	4.134	3.110	0.512	1.260	1.969
5640 75212135	-135-H	0.375	5.315	4.291	0.512	1.260	1.969
5640 75212165	-165-H	0.375	6.496	5.472	0.512	1.260	1.969
5640 75216105	HSK63A -SRS0500A -105-H	0.500	4.134	3.110	0.591	1.457	2.756
5640 75216135	-135-H	0.500	5.315	4.291	0.591	1.457	2.756
5640 75216165	-165-H	0.500	6.496	5.472	0.591	1.457	2.756
5640 75220105	HSK63A -SRS0625A -105-H	0.625	4.134	3.110	0.787	1.575	2.953
5640 75220135	-135-H	0.625	5.315	4.291	0.787	1.575	3.150
5640 75220165	-165-H	0.625	6.496	5.472	0.787	1.575	3.150
5640 75224105	HSK63A -SRS0750A -105-H	0.750	4.134	3.110	1.024	1.654	2.953
5640 75224135	-135-H	0.750	5.315	4.291	1.024	1.654	3.937
5640 75224165	-165-H	0.750	6.496	5.472	1.024	1.654	3.937
5640 77208105	HSK100A -SRS0250A -105-H	0.250	4.134	2.795	0.354	1.024	1.417
5640 77208135	-135-H	0.250	5.315	3.976	0.354	1.024	1.417
5640 77208165	-165-H	0.250	6.496	5.157	0.354	1.024	1.417
5640 77210105	HSK100A -SRS0312A -105-H	0.312	4.134	2.795	0.433	1.024	1.969
5640 77210135	-135-H	0.312	5.315	3.976	0.433	1.024	1.969
5640 77210165	-165-H	0.312	6.496	5.157	0.433	1.024	1.969
5640 77212105	HSK100A -SRS0375A -105-H	0.375	4.134	2.795	0.512	1.260	1.969
5640 77212135	-135-H	0.375	5.315	3.976	0.512	1.260	1.969
5640 77212165	-165-H	0.375	6.496	5.157	0.512	1.260	1.969
5640 77212195	-195-H	0.375	7.677	6.339	0.512	1.260	1.969
5640 77216105	HSK100A -SRS0500A -105-H	0.500	4.134	2.795	0.591	1.457	2.756
5640 77216135	-135-H	0.500	5.315	3.976	0.591	1.457	2.756
5640 77216165	-165-H	0.500	6.496	5.157	0.591	1.457	2.756
5640 77216195	-195-H	0.500	7.677	6.339	0.591	1.457	2.756
5640 77220105	HSK100A -SRS0625A -105-H	0.625	4.134	2.795	0.787	1.575	2.756
5640 77220135	-135-H	0.625	5.315	3.976	0.787	1.575	3.150
5640 77220165	-165-H	0.625	6.496	5.157	0.787	1.575	3.150
5640 77220195	-195-H	0.625	7.677	6.339	0.787	1.575	3.150
5640 77224105	HSK100A -SRS0750A -105-H	0.750	4.134	2.795	1.024	1.654	2.756
5640 77224135	-135-H	0.750	5.315	3.976	1.024	1.654	3.937
5640 77224165	-165-H	0.750	6.496	5.157	1.024	1.654	3.937
5640 77224195	-195-H	0.750	7.677	6.339	1.024	1.654	3.937

Medidas Métricas - Metric Sizes

Unidad : Métrico
Unit : Metric

Código Code	Modelo Model	d	L	L1	D	ℓ1	ℓ	kg
5640 31306090	HSK40A -SRS6A -90	6	90	70	9	26	26 ~ 36	0.5
5640 31306120	-120	6	120	100	9	26	26 ~ 36	0.5
5640 31308090	HSK40A -SRS8A -90	8	90	70	11	26	26 ~ 50	0.5
5640 31308120	-120	8	120	100	11	26	26 ~ 50	0.5
5640 31310090	HSK40A -SRS10A -90	10	90	70	13	32	32 ~ 50	0.5
5640 31310120	-120	10	120	100	13	32	32 ~ 50	0.5
5640 31312090	HSK40A -SRS12A -90	12	90	70	15	37	37 ~ 70	0.5
5640 31312120	-120	12	120	100	15	37	37 ~ 70	0.6
5640 31316090	HSK40A -SRS16A -90	16	90	70	20	40	40 ~ 70	0.6
5640 31316120	-120	16	120	100	20	40	40 ~ 80	0.6
5640 31406090	HSK50A -SRS6A -90	6	90	64	9	26	26 ~ 36	0.6
5640 31406120	-120	6	120	94	9	26	26 ~ 36	0.6
5640 31408090	HSK50A -SRS8A -90	8	90	64	11	26	26 ~ 50	0.6
5640 31408120	-120	8	120	94	11	26	26 ~ 50	0.6
5640 31410090	HSK50A -SRS10A -90	10	90	64	13	32	32 ~ 50	0.7
5640 31410120	-120	10	120	94	13	32	32 ~ 50	0.7
5640 31412090	HSK50A -SRS12A -90	12	90	64	15	37	37 ~ 65	0.7
5640 31412120	-120	12	120	94	15	37	37 ~ 70	0.8
5640 31416105	HSK50A -SRS16A -105	16	105	79	20	40	40 ~ 80	0.8
5640 31416135	-135	16	135	109	20	40	40 ~ 80	0.9
5640 31420105	HSK50A -SRS20A -105	20	105	79	26	42	42 ~ 80	0.9
5640 31420135	-135	20	135	109	26	42	42 ~ 100	1.0
5640 75106105	HSK63A -SRS6A -105-H	6	105	79	9	26	26 ~ 36	0.7
5640 75106135	-135-H	6	135	109	9	26	26 ~ 36	0.7
5640 75106165	-165-H	6	165	139	9	26	26 ~ 36	0.7
5640 75108105	HSK63A -SRS8A -105-H	8	105	79	11	26	26 ~ 50	0.8
5640 75108135	-135-H	8	135	109	11	26	26 ~ 50	0.8
5640 75108165	-165-H	8	165	139	11	26	26 ~ 50	0.8
5640 75110105	HSK63A -SRS10A -105-H	10	105	79	13	32	32 ~ 50	0.9
5640 75110135	-135-H	10	135	109	13	32	32 ~ 50	1.0
5640 75110165	-165-H	10	165	139	13	32	32 ~ 50	1.1
5640 75112105	HSK63A -SRS12A -105-H	12	105	79	15	37	37 ~ 70	1.0
5640 75112135	-135-H	12	135	109	15	37	37 ~ 70	1.0
5640 75112165	-165-H	12	165	139	15	37	37 ~ 70	1.1
5640 75116105	HSK63A -SRS16A -105-H	16	105	79	20	40	40 ~ 75	1.2
5640 75116135	-135-H	16	135	109	20	40	40 ~ 80	1.3
5640 75116165	-165-H	16	165	139	20	40	40 ~ 80	1.5
5640 75120105	HSK63A -SRS20A -105-H	20	105	79	26	42	42 ~ 75	1.1
5640 75120135	-135-H	20	135	109	26	42	42 ~ 100	1.2
5640 75120165	-165-H	20	165	139	26	42	42 ~ 100	1.3
5640 77106105	HSK100A -SRS6A -105-H	6	105	71	9	26	26 ~ 36	2.2
5640 77106135	-135-H	6	135	101	9	26	26 ~ 36	2.2
5640 77106165	-165-H	6	165	131	9	26	26 ~ 36	2.2
5640 77108105	HSK100A -SRS8A -105-H	8	105	71	11	26	26 ~ 50	2.3
5640 77108135	-135-H	8	135	101	11	26	26 ~ 50	2.3
5640 77108165	-165-H	8	165	131	11	26	26 ~ 50	2.3
5640 77110105	HSK100A -SRS10A -105-H	10	105	71	13	32	32 ~ 50	2.4
5640 77110135	-135-H	10	135	101	13	32	32 ~ 50	2.4
5640 77110165	-165-H	10	165	131	13	32	32 ~ 50	2.6
5640 77110195	-195-H	10	195	161	13	32	32 ~ 50	2.6
5640 77112105	HSK100A -SRS12A -105-H	12	105	71	15	37	37 ~ 70	2.4
5640 77112135	-135-H	12	135	101	15	37	37 ~ 70	2.5
5640 77112165	-165-H	12	165	131	15	37	37 ~ 70	2.6
5640 77112195	-195-H	12	195	161	15	37	37 ~ 70	2.7
5640 77116105	HSK100A -SRS16A -105-H	16	105	71	20	40	40 ~ 70	2.5
5640 77116135	-135-H	16	135	101	20	40	40 ~ 80	2.6
5640 77116165	-165-H	16	165	131	20	40	40 ~ 80	2.8
5640 77116195	-195-H	16	195	161	20	40	40 ~ 80	2.9
5640 77120105	HSK100A -SRS20A -105-H	20	105	71	26	42	42 ~ 70	2.6
5640 77120135	-135-H	20	135	101	26	42	42 ~ 100	2.7
5640 77120165	-165-H	20	165	131	26	42	42 ~ 100	2.8
5640 77120195	-195-H	20	195	161	26	42	42 ~ 100	2.9

Siempre use herramientas de zanco de carburo con tolerancia de h6.
Always use carbide shank tools with h6 tolerance.

Ejemplo para Ordenar - Ordering Example

HSK40A - SRS 12 A - 105

Interfaz y diámetro de husillo / Shank size: HSK40A
Diámetro Interno / I.D. (d): SRS 12
Longitud de proyección / Projection length (L): A - 105

Ejemplo para Ordenar - Ordering Example

HSK63A - SRS 0250 A - 105 - H

Interfaz y diámetro de husillo / Shank size: HSK63A
Diámetro Interno / I.D.: SRS 0250
Longitud de proyección / Projection length: A - 105
Barreno de Cambio Manual / Manual clamp hole: H

Tabla de dispositivos térmicos

Heating device chart

Dispositivo término Heating device	Portaherramienta - chuck	
	SRS0250A, SRS0312A SRS6A, SRS8A	SRS0375A~SRS0750A SRS10A~SRS20A
ISG3400	Sí / Yes	Sí / Yes
SRK-HA1, HB2	No	Sí / Yes



- BT
- CAT
- AHO
- HSK-AE/FC
- HSK-T
- C
- UTS
- Máquinas Especializadas
Specialized Machine
- Equipo Relacionado
Related Equipment
- Taladro de Biselado & de Casquillo
Bush & Chamfering Drill
- Milling Chuck
- Collet Holder
- "R" Zero Holder
- Hydraulic Chuck
- Shrink Fit
- Tapping Chuck
- Arbors
- Function Holder
- HSK-E
- HSK-F
- HSK-C
- Dimensions

SYNCHROFIT II

- El diseño elástico único de NT Tool reduce el estrés en el machuelo y mejora la vida de la herramienta de corte.
NT Tools's unique elastic design reduces tapping stress and improves cutting tool life.

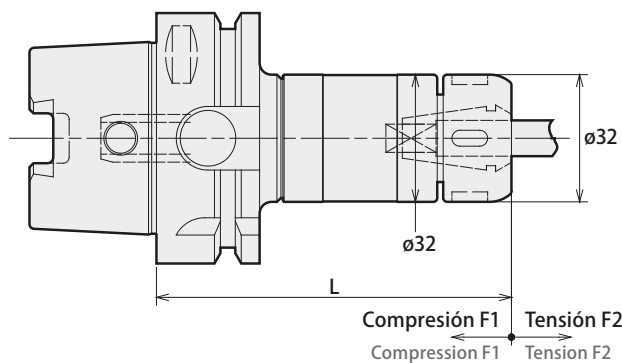

Código Code	Modelo Model	L	Medida de machuelo Tap Size	Compresión F1 Compression F1	Tensión F2 Tension F2	Boquilla Collet	Tuerca ciega Nut	Llave Inglesa Spanner
5810 13016085	HSK40A -SMH16 -85	85	M3~M12 U no.5~U7/16 PT1/8 • PT1/16	0.1	0.1	ER16GH	ERP-16T	FKT-32L
5810 75016090	HSK63A -SMH16 -90	90						

HSK63A, HSK100A cuentan con barreno de cambio manual.

1. La boquilla y Llave inglesa se venden por separado.
2. Para la medida correspondiente al machuelo, consulte la pág. de dimensiones de las boquillas para machuelo.
3. Utilice con una máquina con función sincrónica.

HSK63A, HSK100A have manual clamp holes in the shank.

1. Collet and spanner are sold separately.
2. For the corresponding tap size, refer to the tap collet dimension page.
3. Please use with a machine with synchronous function.

Ejemplo para ordenar - Ordering Example

HSK63A - SMH16 - 85

Interfaz y diámetro de husillo
Shank size

Diámetro Interior
Holder size

Longitud de proyección
Projection length

Boquilla Collet
Pág. 133

Llave Inglesa Spanner
Pág. 133



NOTAS

STM

Synchronous Tap Holder With Easy Tool Length Adjustment

- La longitud de proyección de la herramienta de corte se puede ajustar simplemente girando la circunferencia del portaherramienta.
- Projection length of the cutting tool can be adjusted by simply turning circumference of the holder.

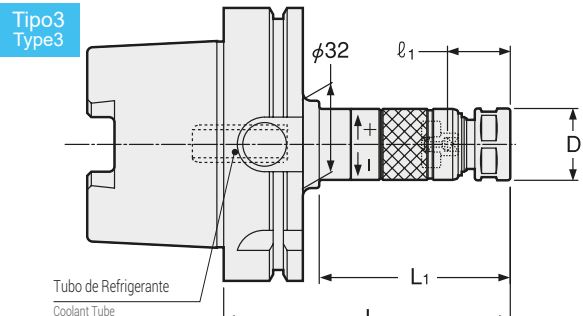
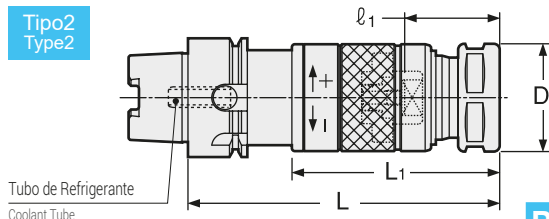
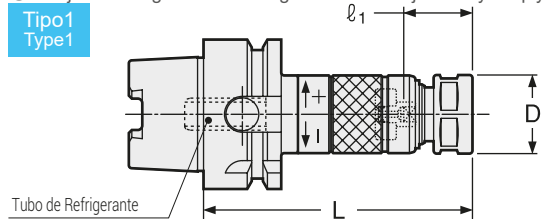

Para consultar las medidas de machuelo adecuadas, favor de dirigirse a la tabla en las pág. 485-486.
 (NOTA) El D.E. de la tuerca del STM8 es de 19 mm.
 For capable tap sizes, please refer to P.485-486 chart.
 (NOTE) Nut O.D. of STM8 is 19mm.

Portaherramienta STM
STM Holder

Boquilla
Collet

Unidad STS
STS Driver

Unidad : Métrico
Unit : Metric

- Tubo de refrigerante incluido.
- Coolant tube is included.

Código Code	Modelo Model	Tipo Type	Medida de machuelo Tap Size	L	L1	D	Tuerca ciega Nut	kg	Boquilla Collet	Unidad preajustada Preset Driver	Llave Inglesa Spanner
5610 13000075	HSK40A -STM8 -75 *	1	Old JIS Taps M4~8 U No8~5/16 OSG Synchro Taps M4~6	75	—	21	KDP-1414		FDC-07	STS-8	Llave con 17 mm de ancho (Flat 17mm width)
5610 13000090	-90	1		90	—	21	KDP-1414				
5610 13000005	-105	1		105	—	21	KDP-1414				
5610 13000020	-120	1		120	—	21	KDP-1414				
5610 13100075	HSK40A -STM12 -75 *	1	Old JIS Taps M4~12 U No8~7/16 PT1/8 OSG Synchro Taps M4~10	75	—	26	HTP-09		FSC-09	STS-12	S-1L
5610 13100090	-90	1		90	—	26	HTP-09				
5610 13100005	-105	1		105	—	26	HTP-09				
5610 13100020	-120	1		120	—	26	HTP-09				
5610 13300005	HSK40A -STM18 -105	2	Old JIS Taps M14~18 U1/2~3/4 PT1/4~3/8 OSG Synchro Taps M12~14	105	70	36	HTP-16	0.6	FSC-16	STS-18	S-4L
5610 13300020	-120	2		120	85	36	HTP-16				
5610 13300035	-135	2		135	100	36	HTP-16				
5610 13300050	-150	2		150	115	36	HTP-16				
5610 14000075	HSK50A -STM8 -75 *	1	Old JIS Taps M4~8 U No8~5/16 OSG Synchro Taps M4~6	75	—	21	KDP-1414		FDC-07	STS-8	Llave con 17 mm de ancho (Flat 17mm width)
5610 14000090	-90	1		90	—	21	KDP-1414	0.6			
5610 14000005	-105	1		105	—	21	KDP-1414	0.6			
5610 14000020	-120	1		120	—	21	KDP-1414				
5610 14100090	HSK50A -STM12 -90	1	Old JIS Taps M4~12 U No8~7/16 PT1/8 OSG Synchro Taps M4~10	90	—	26	HTP-09	0.6	FSC-09	STS-12	S-1L
5610 14100005	-105	1		105	—	26	HTP-09	0.7			
5610 14100020	-120	1		120	—	26	HTP-09				
5610 14300005	HSK50A -STM18 -105	1		105	—	36	HTP-16	0.8			
5610 14300020	-120	1	Old JIS Taps M14~18 U1/2~3/4 PT1/4~3/8 OSG Synchro Taps M12~14	120	—	36	HTP-16	0.9	FSC-16	STS-18	S-4L
5610 14300035	-135	1		135	—	36	HTP-16	1.0			
5610 14300050	-150	1		150	—	36	HTP-16				
5610 75000075	HSK63A -STM8 -75-H *	1		Old JIS Taps M4~8 U No8~5/16 OSG Synchro Taps M4~6	75	—	21	KDP-1414			
5610 75000090	-90-H	1	90		—	21	KDP-1414				
5610 75000005	-105-H	1	105		—	21	KDP-1414				
5610 75000020	-120-H	1	120		—	21	KDP-1414				
5610 75000035	-135-H	1	135		—	21	KDP-1414				
5610 75000050	-150-H	1	150		—	21	KDP-1414				
5610 75100090	HSK63A -STM12 -90-H	1	Old JIS Taps M4~12 U No8~7/16 PT1/8 OSG Synchro Taps M4~10	90	—	26	HTP-09	0.9	FSC-09	STS-12	S-1L
5610 75100005	-105-H	1		105	—	26	HTP-09	0.9			
5610 75100020	-120-H	1		120	—	26	HTP-09	1.0			
5610 75100035	-135-H	1		135	—	26	HTP-09	1.0			
5610 75100050	-150-H	1		150	—	26	HTP-09	1.1			
5610 75100080	-180-H	1		180	—	26	HTP-09	1.2			
5610 75300005	HSK63A -STM18 -105-H	1	Old JIS Taps M14~18 U1/2~3/4 PT1/4~3/8 OSG Synchro Taps M12~14	105	—	36	HTP-16	1.1	FSC-16	STS-18	S-4L
5610 75300020	-120-H	1		120	—	36	HTP-16	1.2			
5610 75300035	-135-H	1		135	—	36	HTP-16	1.3			
5610 75300050	-150-H	1		150	—	36	HTP-16	1.4			
5610 75300080	-180-H	1		180	—	36	HTP-16				
5610 75400020	HSK63A -STM30 -120-H	1		Old JIS Taps M20~30 U7/8~1-1/8 PT1/2~3/4 OSG Synchro Taps M16~27	120	—	46	HTP-22			
5610 75400035	-135-H	1	135		—	46	HTP-22				
5610 75400050	-150-H	1	150		—	46	HTP-22				
5610 75400080	-180-H	1	180		—	46	HTP-22				
5610 77000090	HSK100A -STM8 -90-H *	3	Old JIS Taps M4~8 U No8~5/16 OSG Synchro Taps M4~6	90	53	21	KDP-1414		FDC-07	STS-8	Llave con 17 mm de ancho (Flat 17mm width)
5610 77000005	-105-H	3		105	68	21	KDP-1414				
5610 77000020	-120-H	3		120	83	21	KDP-1414				
5610 77000035	-135-H	3		135	98	21	KDP-1414				
5610 77000050	-150-H	3		150	113	21	KDP-1414				
5610 77000065	-165-H	3		165	128	21	KDP-1414				

Código Code	Modelo Model	Tipo Type	Medida de machuelo Tap Size	L	L1	D	Tuerca ciega Nut	kg	Boquilla Collet	Unidad preajustada Preset Driver	Llave Inglesa Spanner
5610 77100090	HSK100A -STM12 -90-H *	3	Old JIS Taps M4~12 U No8~7/16 PT1/8 OSG Synchro Taps M4~10	90	53	26	HTP-09	2.3	FSC-09	STS-12	S-1L
5610 77100005	-105-H	3		105	68	26	HTP-09				
5610 77100020	-120-H	3		120	83	26	HTP-09				
5610 77100035	-135-H	3		135	98	26	HTP-09				
5610 77100050	-150-H	3		150	113	26	HTP-09				
5610 77100080	-180-H	3	180	143	26	HTP-09					
5610 77300005	HSK100A -STM18 -105-H	1	Old JIS Taps M14~18 U1/2~3/4 PT1/4~3/8 OSG Synchro Taps M12~14	105	-	36	HTP-16	2.4	FSC-16	STS-18	S-4L
5610 77300020	-120-H	1		120	-	36	HTP-16				
5610 77300035	-135-H	1		135	-	36	HTP-16				
5610 77300050	-150-H	1		150	-	36	HTP-16				
5610 77300080	-180-H	1		180	-	36	HTP-16				
5610 77400020	HSK100A -STM30 -120-H	1	Old JIS Taps M20~30 U7/8~1-1/8 PT1/2~3/4 OSG Synchro Taps M16~27	120	-	46	HTP-22	2.7	FSC-22	STS-30	S-5L
5610 77400035	-135-H	1		135	-	46	HTP-22				
5610 77400050	-150-H	1		150	-	46	HTP-22				
5610 77400080	-180-H	1		180	-	46	HTP-22				
5610 77400010	-210-H	1		210	-	46	HTP-22				

- 1.La boquilla, la llave inglesa y unidad preajustada se venden por separado.
- 2.Favor de ver a continuación para conocer la dimensión $\ell 1$.
- 3.El STM8 puede hacer orificios de machuelo menores a M4. Las boquillas a usar son como se especifica a continuación.
M1.M2.6: FDC-03007-※※ M3-M3.5: FDC-04007-※※
La unidad del machuelo no se usará para los usos antes mencionados.
1.Collet, spanner and preset driver are sold separately.
2.Please see below for $\ell 1$ dimension.
3.Tap holes smaller than M4 can be made by STM8. Collets to be used are as follows.
M1-M2.6: FDC-03007- ※※ M3-M3.5: FDC-04007- ※※
Tap drive will not be used for the above usages.

Boquilla Collet
Pág. 342



Tornillo de preajuste Preset screw
Pág. 342-343



Ejemplo para Ordenar - Ordering Example
HSK40A - STM 8 - 90

Interfaz y diámetro de husillo Shank size

Medida de portaherramienta Holder size

Longitud de proyección Projection length (L)

Dimensión $\ell 1$ para el STM - $\ell 1$ Dimension for STM

Machuelos JIS antiguas - Old JIS Taps

Sin vena de refrigerante a través del centro - Without center-through coolant		
Medida de machuelo - Tap Size	$\ell 1$	$\ell 1(*)$
M4 ~ 6 U No.8 ~ 1/4	21 ~ 35	21 ~ 26
M7 ~ 12 U 5/16 ~ U7/16 PT1/8	23 ~ 37	23 ~ 28
M13 ~ 15 U 1/2 ~ 5/8 PT1/4	28 ~ 42	-
M16 ~ 17	32 ~ 45	-
M18 ~ 27 U 3/4 ~ U1 PT3/8 ~ 5/8	33 ~ 47	-
M30 U1-1/8 PT3/4	38 ~ 52	-

Con vena de refrigerante a través del centro With center-through coolant (STM8)		
Medida de machuelo - Tap Size	$\ell 1$	$\ell 1(*)$
M4 ~ 6 U No.8 ~ 1/4	25 ~ 35	25 ~ 26
M7 ~ 8 U5/16	26 ~ 37	26 ~ 28

Con vena de refrigerante a través del centro With center-through coolant (STM12~30)		
Medida de machuelo - Tap Size	$\ell 1$	$\ell 1(*)$
M4 ~ 6 U No.8 ~ 1/4	24 ~ 35	24 ~ 26
M7 ~ 10 U 5/16 ~ 3/8	25 ~ 37	25 ~ 28
M11 ~ 12 U 7/16 PT 1/8	26 ~ 37	26 ~ 28
U1/2	32 ~ 42	-
M13 ~ 15 U9/16	33 ~ 42	-
U5/8 PT1/4	34 ~ 42	-
M16	35 ~ 46	-
M18 U 3/4 PT3/8	36 ~ 47	-
M20 ~ 21 PT1/2	40 ~ 47	-
M22 U 7/8	41 ~ 47	-
M23	42 ~ 47	-
M24 ~ 25 PT5/8	43 ~ 47	-
M26 ~ 27 U1	44 ~ 47	-
M28	45 ~ 52	-
M30 PT3/4	46 ~ 52	-
U 1-1/8	48 ~ 52	-

Machuelos sincronizados OSG - OSG Synchro Taps

Sin vena refrigerante a través del centro - Without center-through coolant		
Medida de machuelo - Tap Size	$\ell 1$	$\ell 1(*)$
M4 ~ 6	21 ~ 35	21 ~ 26
M8 ~ 10	23 ~ 37	23 ~ 28
M12 ~ 14	28 ~ 42	-
M16 ~ 27	33 ~ 47	-

Con vena de refrigerante a través del centro With center-through coolant (STM8)		
Medida de machuelo - Tap Size	$\ell 1$	$\ell 1(*)$
M4 ~ 6	25 ~ 35	25 ~ 26

Con vena de refrigerante a través del centro With center-through coolant (STM12~30)		
Medida de machuelo - Tap Size	$\ell 1$	$\ell 1(*)$
M4 ~ 6	24 ~ 35	24 ~ 26
M8 ~ 10	26 ~ 37	26 ~ 28
M12	33 ~ 42	-
M14	34 ~ 42	-
M16 ~ 20	40 ~ 46	-
M22 ~ 27	44 ~ 47	-

YAMAWA X Series

Sin vena refrigerante a través del centro - Without center-through coolant		
Medida de machuelo - Tap Size	$\ell 1$	$\ell 1(*)$
M6 M8	23 ~ 37	23 ~ 28
M10 M12	28 ~ 42	-

Con vena de refrigerante a través del centro With center-through coolant (STM8)		
Medida de machuelo - Tap Size	$\ell 1$	$\ell 1(*)$
M6	26 ~ 37	26 ~ 28

Con vena de refrigerante a través del centro With center-through coolant (STM12~30)		
Medida de machuelo - Tap Size	$\ell 1$	$\ell 1(*)$
M6	25 ~ 37	25 ~ 28
M8	26 ~ 37	26 ~ 28
M10	33 ~ 42	-
M12	34 ~ 42	-

Tabla de referencia de las medidas de machuelo de roscar (boquilla, conductor de preajuste)

Tap size reference chart (collet, preset driver)

FDC 07 ó/ or FSC - boquilla (collet)

Unidad de cambio del conductor de preajuste y herramienta
Preset driver & tool for changing driver

Tipo OH - Type OH

● La boquilla OH debe usarse para el abastecimiento de refrigerante a través del centro y para el abastecimiento de refrigerante externo.
● OH type collet should be used for center-through coolant feeding and external coolant feeding.

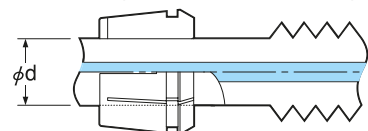

Tipo C - Type C

● Cuando se necesita el abastecimiento de refrigerante "a través de la boquilla"
● when "collet-through" coolant feeding is needed.

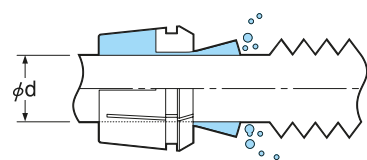

Tipo STS - Type STS

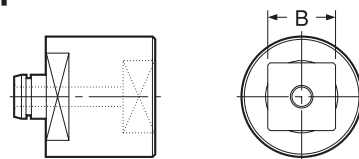

Tipo STS-R - Type STS

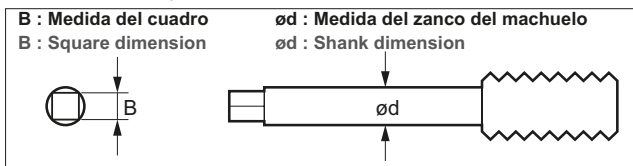

Favor de elegir el tipo OH para un uso sin refrigerante.
Please select OH type for non-coolant use.

Modelo de portaherramienta Holder Model	Medida de machuelo Tap Size (ANSI)	ød (pulgada-inch)	ød (mm)	Modelo de Boquilla Collet Model (OH or C)	B (pulgada-inch)	B (mm)	Conductor de preajuste Preset Driver
STM8	#0-6	0.141	3.5814	FDC-03607**	0.110	2.794	STS8- □ 2.8
	#8	0.168	4.2672	FDC-04307**	0.131	3.3274	STS8- □ 3.4
	#10	0.194	4.9276	FDC-05007**	0.152	3.8608	STS8- □ 4.0
	#12	0.22	5.588	FDC-05607**	0.165	4.191	STS8- □ 4.2
	1/4	0.255	6.477	FDC-06507**	0.191	4.8514	STS8- □ 5.0
STM12	#0-6	0.141	3.5814	FSC-09-3.6**	0.110	2.794	STS12- □ 2.8
	#8	0.168	4.2672	FSC-09-4.3**	0.131	3.3274	STS12- □ 3.4
	#10	0.194	4.9276	FSC-09-5.0**	0.152	3.8608	STS12- □ 4.0
	#12	0.22	5.588	FSC-09-5.6**	0.165	4.191	STS12- □ 4.2
	1/4	0.255	6.477	FSC-09-6.5**	0.191	4.8514	STS12- □ 5.0
	1/8SPT	0.313	7.9502	FSC-09-8.0**	0.234	5.9436	STS12- □ 6.0
	5/16	0.318	8.0772	FSC-09-8.1**	0.238	6.0452	STS12- □ 6.1
STM18	7/16	0.323	8.2042	FSC-09-8.3**	0.242	6.1468	STS12- □ 6.2
	1/2	0.367	9.3218	FSC-16-9.4**	0.275	6.985	STS18- □ 7.0
	3/8	0.381	9.6774	FSC-16-9.7**	0.286	7.2644	STS18- □ 7.3
	9/16	0.429	10.8966	FSC-16-10.9**	0.322	8.1788	STS18- □ 8.2
	1/8LPT	0.437	11.0998	FSC-16-11.1**	0.328	8.3312	STS18- □ 8.4
	5/8	0.48	12.192	FSC-16-12.2**	0.360	9.144	STS18- □ 9.2
	11/16	0.542	13.7668	FSC-16-13.8**	0.406	10.3124	STS18- □ 10.4
STM30	1/4PT	0.562	14.2748	FSC-16-14.3**	0.421	10.6934	STS18- □ 10.7
	3/4	0.59	14.986	FSC-22-15.0**	0.442	11.2268	STS30- □ 11.3
	13/16	0.652	16.5608	FSC-22-16.6**	0.489	12.4206	STS30- □ 12.5
	7/8	0.697	17.7038	FSC-22-17.8**	0.523	13.2842	STS30- □ 13.3
	3/8PT	0.7	17.78	FSC-22-17.8**	0.531	13.4874	STS30- □ 13.5
	1	0.8	20.32	FSC-22-20.4**	0.600	15.24	STS30- □ 15.3

Para DIN e ISO, favor de dirigirse a la pág. 485-486.
For DIN and ISO, please refer to P. 485-486.

Ejemplo para Ordenar - Ordering Example

FSC - 22 - 20.4 - OH

Medida de la boquilla
Collet size

D.I. de la boquilla
Collet I.D. (d)

OH: Para herramienta con vena de lubricación
C: Para refrigeración a través de los costados de la boquilla
OH: For tool with coolant hole
C: For collet through

Combinación de accesorios - Accessories combination

Portaherramienta para machuelo - Tap holder	Boquilla Collet	Conductor de preajuste Preset Driver		Tuerca ciega Nut		Unidad de cambio de herramienta Tool changing driver		Llave Inglesa Spanner	
Modelo Model	Modelo Model	Modelo Model	Código Code	Modelo Model	Código Code	Modelo Model	Código Code	Modelo Model	Código Code
STM8	FDC-07	STS8	3914 0100**03	KDP-1414	0070 01001407	STS-R0	3914 00000006	Llave con 17 mm de ancho (Flat 17mm width)	
STM12	FSC-09	STS12	3914 1100**03	HTP-09	1314 00000009	STS-R1	3914 10000006	S-1L	0803 00000011
STM18	FSC-16	STS18	3914 310**03	HTP-16	1314 00000016	STS-R2	3914 30000006	S-4L	0803 00000014
STM30	FSC-22	STS30	3914 410**03	HTP-22	1314 00000022	STS-R2	3914 30000006	S-5L	0803 00000015

Tabla de referencia de las medidas de machuelo (boquilla, conductor de preajuste)

Tap size reference chart (collet, preset driver)

FDC 07 ó - or FSC - boquilla (collet)

Tipo OH - Type OH

● La boquilla OH debe usarse para el abastecimiento de refrigerante a través del centro y para el abastecimiento de refrigerante externo.

● OH type collet should be used for center-through coolant feeding and external coolant feeding.

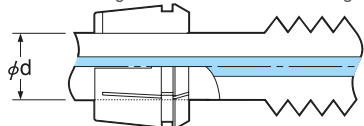

Tipo C - Type C

● Cuando se necesita el abastecimiento de refrigerante "a través de la boquilla"

● when "collet-through" coolant feeding is needed.

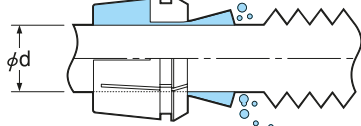

※ Favor de elegir el tipo OH para un uso sin refrigerante.
 ※ Please select OH type for non-coolant use.

Unidad de cambio del conductor de preajuste y herramienta Preset driver & tool for changing driver

Tipo STS - Type STS

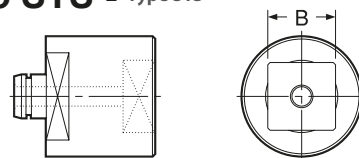

Tipo STS-R - Type STS



Modelo de portaherramienta Holder Model	Medida de machuelo - Tap Size					Ød	Modelo de Boquilla Collet Model (OH or C)	B	Unidad preajustada Preset Driver	Herramienta para cambiar la Unidad preajustada/Tool for Changing Driver
	Estándar JIS viejo - Old JIS Taps			Machuelo sincronizado OSG-OSG Synchro-Taps	YAMAWA X Series					
	Rosca métrica Metric Thread	Rosca unificada Unified Thread	Rosca de tubo ahusado - Pipe Taper Thread							
STM8	M4~M4.5	UNo.8				5.0	FDC-05007-**	4.0	STS8-□4.0	STS-R0
	M5~M5.5	UNo.10~12				5.5	FDC-05507-**	4.5	STS8-□4.5	STS-R0
	M6	U1/4		M4~M6		6.0	FDC-06007-**	4.5	STS8-□4.5	STS-R0
					M6	6.0	FDC-06007-**	4.9	STS8-□4.9	STS-R0
			U5/16			6.1	FDC-06107-**	5.0	STS8-□5.0	STS-R0
						6.2	FDC-06207-**	5.0	STS8-□5.0	STS-R0
STM12	M4~M4.5	UNo.8				5.0	FSC-09-5.0-**	4.0	STS12-□4.0	STS-R1
	M5~M5.5	UNo.10~12				5.5	FSC-09-5.5-**	4.5	STS12-□4.5	STS-R1
	M6	U1/4		M4~M6		6.0	FSC-09-6.0-**	4.5	STS12-□4.5	STS-R1
					M6	6.0	FSC-09-6.0-**	4.9	STS12-□4.9	STS-R1
			U5/16			6.1	FSC-09-6.1-**	5.0	STS12-□5.0	STS-R1
	M7~8					6.2	FSC-09-6.2-**	5.0	STS12-□5.0	STS-R1
	M9~M10	U3/8				7.0	FSC-09-7.0-**	5.5	STS12-□5.5	STS-R1
	M11	U7/16	PT1/16~1/8	M8~M10	M8	8.0	FSC-09-8.0-**	6.2	STS12-□6.2	STS-R1
STM18	M12					8.0	FSC-09-8.0-**	6.0	STS12-□6.0	STS-R1
		U1/2				8.5	FSC-09-8.5-**	6.5	STS12-□6.5	STS-R1
	M13					9.0	FSC-16-9.0-**	7.0	STS18-□7.0	STS-R2
				M12	M10	9.5	FSC-16-9.5-**	7.0	STS18-□7.0	STS-R2
	M14~15	U9/16				10.0	FSC-16-10.0-**	8.0	STS18-□8.0	STS-R2
			PT1/4			10.5	FSC-16-10.5-**	8.0	STS18-□8.0	STS-R2
		U5/8		M14	M12	11.0	FSC-16-11.0-**	9.0	STS18-□9.0	STS-R2
	M16					12.0	FSC-16-12.0-**	9.0	STS18-□9.0	STS-R2
	M17					12.5	FSC-16-12.5-**	10.0	STS18-□10.0	STS-R2
	M18~M19	U3/4	PT3/8			13.0	FSC-16-13.0-**	10.0	STS18-□10.0	STS-R2
STM30	M20					14.0	FSC-16-14.0-**	11.0	STS18-□11.0	STS-R2
	M21			M16~M20		15.0	FSC-22-15.0-**	12.0	STS30-□12.0	STS-R2
	M22	U7/8				16.0	FSC-22-16.0-**	12.0	STS30-□12.0	STS-R2
	M23		PT1/2			17.0	FSC-22-17.0-**	13.0	STS30-□13.0	STS-R2
	M24~M25		PT5/8			18.0	FSC-22-18.0-**	14.0	STS30-□14.0	STS-R2
	M26~M27	U1		M22~M27		19.0	FSC-22-19.0-**	15.0	STS30-□15.0	STS-R2
	M28					20.0	FSC-22-20.0-**	15.0	STS30-□15.0	STS-R2
		U1-1/8				21.0	FSC-22-21.0-**	17.0	STS30-□17.0	STS-R2
	M30		PT3/4			22.0	FSC-22-22.0-**	17.0	STS30-□17.0	STS-R2
					23.0	FSC-22-23.0-**	17.0	STS30-□17.0	STS-R2	

Ejemplo para Ordenar - Ordering Example

FSC - 22 - 20.0 - OH

Medida de la boquilla
Collet size

D.I. de la boquilla
Collet I.D. (d)

OH: Para herramienta con vena de lubricación
C: Para refrigeración a través de los costados de la boquilla
OH: For tool with coolant hole
C: For collet through

Combinación de accesorios - Accessories combination

Portaherramienta para machuelo - Tap holder	Boquilla Collet	Conductor de preajuste Preset Driver		Tuerca ciega Nut		Unidad de cambio de herramienta Tool changing driver		Llave Inglesa Spanner	
Modelo Model	Modelo Model	Modelo Model	Código Code	Modelo Model	Código Code	Modelo Model	Código Code	Modelo Model	Código Code
STM8	FDC-07	STS8	3914 0100**03	KDP-1414	0070 01001407	STS-R0	3914 00000006	Llave con 17 mm de ancho (Flat 17mm width)	
STM12	FSC-09	STS12	3914 1100**03	HTP-09	1314 00000009	STS-R1	3914 10000006	S-1L	0803 00000011
STM18	FSC-16	STS18	3914 310***03	HTP-16	1314 00000016	STS-R2	3914 30000006	S-4L	0803 00000014
STM30	FSC-22	STS30	3914 410***03	HTP-22	1314 00000022	STS-R2	3914 30000006	S-5L	0803 00000015

Boquilla para machuelo - Collet For Tapper

FSC-OH

Para herramienta con orificio para refrigerante
For tool with coolant hole

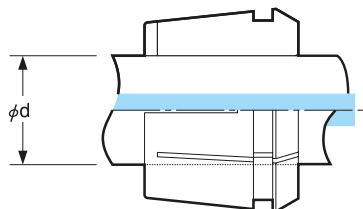

Diá. del zanco de la herramienta - Tool Shank Dia.		Medida Size	Código Code
ød (inch)	ød (mm)		
ø 0.141	ø 3.6	FSC-09-3.6-OH	—
ø 0.168	ø 4.3	FSC-09-4.3-OH	1334 00104309
ø 0.194	ø 5.0	FSC-09-5.0-OH	1334 00105009
ø 0.220	ø 5.6	FSC-09-5.6-OH	1334 00105609
ø 0.216	ø 5.5	FSC-09-5.5-OH	1334 00105509
ø 0.236	ø 6.0	FSC-09-6.0-OH	1334 00106009
ø 0.240	ø 6.1	FSC-09-6.1-OH	1334 00106109
ø 0.244	ø 6.2	FSC-09-6.2-OH	1334 00106209
ø 0.255	ø 6.5	FSC-09-6.5-OH	1334 00106509
ø 0.275	ø 7.0	FSC-09-7.0-OH	1334 00107009
ø 0.314	ø 8.0	FSC-09-8.0-OH	1334 00108009
ø 0.313	ø 8.0	FSC-09-8.0-OH	1334 00108009
ø 0.318	ø 8.1	FSC-09-8.1-OH	1334 00108109
ø 0.323	ø 8.3	FSC-09-8.3-OH	1334 00108309
ø 0.334	ø 8.5	FSC-09-8.5-OH	1334 00108509
ø 0.354	ø 9.0	FSC-16-9.0-OH	1334 00109016
ø 0.367	ø 9.4	FSC-16-9.4-OH	1334 00109416
ø 0.374	ø 9.5	FSC-16-9.5-OH	1334 00109516
ø 0.381	ø 9.7	FSC-16-9.7-OH	1334 00109716
ø 0.393	ø 10.0	FSC-16-10.0-OH	1334 00110016
ø 0.413	ø 10.5	FSC-16-10.5-OH	1334 00110516
ø 0.429	ø 10.9	FSC-16-10.9-OH	1334 00110916
ø 0.433	ø 11.0	FSC-16-11.0-OH	1334 00111016
ø 0.437	ø 11.1	FSC-16-11.1-OH	1334 00111116
ø 0.472	ø 12.0	FSC-16-12.0-OH	1334 00112016
ø 0.480	ø 12.2	FSC-16-12.2-OH	1334 00112216
ø 0.492	ø 12.5	FSC-16-12.5-OH	1334 00112516
ø 0.511	ø 13.0	FSC-16-13.0-OH	1334 00113016
ø 0.542	ø 13.8	FSC-16-13.8-OH	1334 00113816
ø 0.551	ø 14.0	FSC-16-14.0-OH	1334 00114016
ø 0.562	ø 14.3	FSC-16-14.3-OH	1334 00114316
ø 0.590	ø 15.0	FSC-22-15.0-OH	1334 00115022
ø 0.629	ø 16.0	FSC-22-16.0-OH	1334 00116022
ø 0.652	ø 16.6	FSC-22-16.6-OH	1334 00116622
ø 0.669	ø 17.0	FSC-22-17.0-OH	1334 00117022
ø 0.697	ø 17.8	FSC-22-17.8-OH	1334 00117822
ø 0.700	ø 17.8	FSC-22-17.8-OH	1334 00117822
ø 0.708	ø 18.0	FSC-22-18.0-OH	1334 00118022
ø 0.748	ø 19.0	FSC-22-19.0-OH	1334 00119022
ø 0.800	ø 20.4	FSC-22-20.4-OH	1334 00120422
ø 0.787	ø 20.0	FSC-22-20.0-OH	1334 00120022
ø 0.826	ø 21.0	FSC-22-21.0-OH	1334 00121022
ø 0.866	ø 22.0	FSC-22-22.0-OH	1334 00122022
ø 0.905	ø 23.0	FSC-22-23.0-OH	1334 00123022

FSC-C

Para refrigerante a través de la boquilla
For Collet through

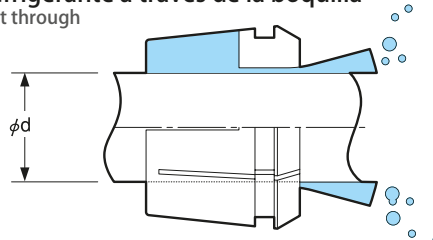

Diá. del zanco de la herramienta - Tool Shank Dia.		Medida Size	Código Code
ød (inch)	ød (mm)		
ø 0.141	ø 3.6	FSC-09-3.6-C	—
ø 0.168	ø 4.3	FSC-09-4.3-C	1335 00104309
ø 0.194	ø 5.0	FSC-09-5.0-C	1335 00105009
ø 0.220	ø 5.6	FSC-09-5.6-C	1335 00105609
ø 0.216	ø 5.5	FSC-09-5.5-C	1335 00105509
ø 0.236	ø 6.0	FSC-09-6.0-C	1335 00106009
ø 0.240	ø 6.1	FSC-09-6.1-C	1335 00106109
ø 0.244	ø 6.2	FSC-09-6.2-C	1335 00106209
ø 0.255	ø 6.5	FSC-09-6.5-C	1335 00106509
ø 0.275	ø 7.0	FSC-09-7.0-C	1335 00107009
ø 0.314	ø 8.0	FSC-09-8.0-C	1335 00108009
ø 0.313	ø 8.0	FSC-09-8.0-C	1335 00108009
ø 0.318	ø 8.1	FSC-09-8.1-C	1335 00108109
ø 0.323	ø 8.3	FSC-09-8.3-C	1335 00108309
ø 0.334	ø 8.5	FSC-09-8.5-C	1335 00108509
ø 0.354	ø 9.0	FSC-16-9.0-C	1335 00109016
ø 0.367	ø 9.4	FSC-16-9.4-C	1335 00109416
ø 0.374	ø 9.5	FSC-16-9.5-C	1335 00109516
ø 0.381	ø 9.7	FSC-16-9.7-C	1335 00109716
ø 0.393	ø 10.0	FSC-16-10.0-C	1335 00110016
ø 0.413	ø 10.5	FSC-16-10.5-C	1335 00110516
ø 0.429	ø 10.9	FSC-16-10.9-C	1335 00110916
ø 0.433	ø 11.0	FSC-16-11.0-C	1335 00111016
ø 0.437	ø 11.1	FSC-16-11.1-C	1335 00111116
ø 0.472	ø 12.0	FSC-16-12.0-C	1335 00112016
ø 0.480	ø 12.2	FSC-16-12.2-C	1335 00112216
ø 0.492	ø 12.5	FSC-16-12.5-C	1335 00112516
ø 0.511	ø 13.0	FSC-16-13.0-C	1335 00113016
ø 0.542	ø 13.8	FSC-16-13.8-C	1335 00113816
ø 0.551	ø 14.0	FSC-16-14.0-C	1335 00114016
ø 0.562	ø 14.3	FSC-16-14.3-C	1335 00114316
ø 0.590	ø 15.0	FSC-22-15.0-C	1335 00115022
ø 0.629	ø 16.0	FSC-22-16.0-C	1335 00116022
ø 0.652	ø 16.6	FSC-22-16.6-C	1335 00116622
ø 0.669	ø 17.0	FSC-22-17.0-C	1335 00117022
ø 0.697	ø 17.8	FSC-22-17.8-C	1335 00117822
ø 0.700	ø 17.8	FSC-22-17.8-C	1335 00117822
ø 0.708	ø 18.0	FSC-22-18.0-C	1335 00118022
ø 0.748	ø 19.0	FSC-22-19.0-C	1335 00119022
ø 0.800	ø 20.4	FSC-22-20.4-C	1335 00120422
ø 0.787	ø 20.0	FSC-22-20.0-C	1335 00120022
ø 0.826	ø 21.0	FSC-22-21.0-C	1335 00121022
ø 0.866	ø 22.0	FSC-22-22.0-C	1335 00122022
ø 0.905	ø 23.0	FSC-22-23.0-C	1335 00123022

Se deberá elegir el tipo OH en caso de que no se use el refrigerante desde el husillo de la máquina.
OH type shall be selected in case not utilizing coolant through from the machine spindle.

Ejemplo para Ordenar - Ordering Example

FSC - 16 - 9.0 - OH
Series 16 Diá. del zanco de la herramienta
16 Series Tool Shank Dia.

Ejemplo para Ordenar - Ordering Example

FSC - 16 - 9.0 - C
Series 16 Diá. del zanco de la herramienta
16 Series Tool Shank Dia.

STP

Synchro Tapping Chuck

- Adaptador del machuelo de cambio rápido
- Quick-changeable tap adapter.

STP

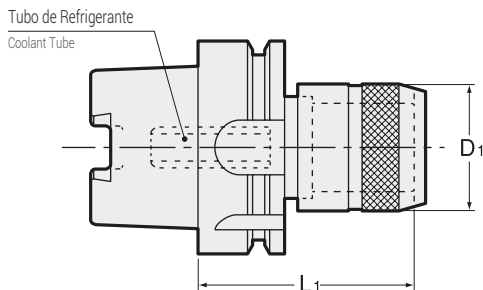

- Tubo de refrigerante incluido.
- Coolant tube is included.

⚠ Para conocer las medidas adecuadas del machuelo, consulte la tabla en la pág.485.
For capable tap sizes, please refer to P. 485 chart.

STC (Opcional-Optional)

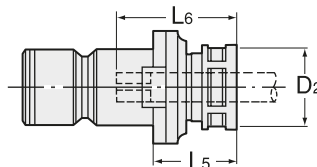

WE (Opcional-Optional)

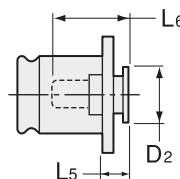

WEN • B (Opcional-Optional)

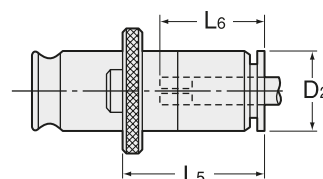

Medidas Métricas - Metric Sizes

Unidad : Métrico
Unit : Metric

Código Code	Modelo Model	L1	D1	kg	Medida del adaptador Adapter Size	L5	D2	Medida de machuelo - Tap Size			
								Rosca métrica Metric thread	Machuelo sincronizado de OSG - OSG synchro tap	Tubo de machuelo Pipe tap	ANSI
5520 13001080	HSK40A -STP1 -80	80	38	0.6	STC1- ***	26	26	M3 ~ M12	M3 ~ M10	PIPE (PT,PS,PF) 1/8	#8-12, 1/4, 5/16, 7/16, 1/8SS
5520 13001110	-110	110	38	WEN1B- ***	33	19					
				WE1- ***	7	19					
5520 14001080	HSK50A -STP1 -80	80	38	0.8	STC1- ***	26	26	M3 ~ M12	M3 ~ M10	PIPE (PT,PS,PF) 1/8	#8-12, 1/4, 5/16, 7/16, 1/8SS
5520 14001110	-110	110	38	1.1	WEN1B- ***	33	19				
				WE1- ***	7	19					
5520 14002100	HSK50A -STP2 -100	100	55	1.2	STC2- ***	35	36	M8 ~ M20	M8 ~ M14	PIPE (PT,PS,PF) 1/8 PIPE (PT,PS,PF) 1/4 PIPE (PT,PS,PF) 3/8	1/4-3/4, 1/8SS, 1/8LS, 1/4P
5520 14002130	-130	130	55	1.5	WEN2B- ***	59	30				
				WE2- ***	11	30					
5520 75001080	HSK63A -STP1 -80-H	80	38	1.0	STC1- ***	26	26	M3 ~ M12	M3 ~ M10	PIPE (PT,PS,PF) 1/8	#8-12, 1/4, 5/16, 7/16, 1/8SS
5520 75001110	-110-H	110	38	1.3	WEN1B- ***	33	19				
				WE1- ***	7	19					
5520 75002100	HSK63A -STP2 -100-H	100	55		STC2- ***	35	36	M8 ~ M20	M8 ~ M14	PIPE (PT,PS,PF) 1/8 PIPE (PT,PS,PF) 1/4 PIPE (PT,PS,PF) 3/8	1/4-3/4, 1/8SS, 1/8LS, 1/4P
5520 75002130	-130-H	130	55	2.0	WEN2B- ***	59	30				
				WE2- ***	11	30					
5520 77001095	HSK100A -STP1 -95-H	95	38	2.5	STC1- ***	26	26	M3 ~ M12	M3 ~ M10	PIPE (PT,PS,PF) 1/8	#8-12, 1/4, 5/16, 7/16, 1/8SS
5520 77001125	-125-H	125	38		WEN1B- ***	33	19				
				WE1- ***	7	19					
5520 77002115	HSK100A -STP2 -115-H	115	55	3.2	STC2- ***	35	36	M8 ~ M20	M8 ~ M14	PIPE (PT,PS,PF) 1/8 PIPE (PT,PS,PF) 1/4 PIPE (PT,PS,PF) 3/8	1/4-3/4, 1/8SS, 1/8LS, 1/4P
5520 77002145	-145-H	145	55	3.7	WEN2B- ***	59	30				
				WE2- ***	11	30					

Los valores L5 están en el empaque de la rosca métrica
L5 values are in the case of metric thread.

Favor de dirigirse a la pág. 480, 482 para consultar la dimensión L6 del WE, WEN • B
Please refer to P. 480, 482 for L6 dimension of WE, WEN • B.

STC L6 Dimensión - Dimension

STC1 L6	M3	M4	M5	M6	M8	M10	M11	M12	Pipe1/8
MIN	24	26	31	31	32	32	32	33	34
MAX	29	31	35	35	37	37	37	37	38

STC2 L6	M8	M10	M11	M12	M14	M16	M17	M18	M20	Pipe1/8	Pipe1/4	Pipe3/8
MIN	34	34	33	35	39	41	41	43	43	29	29	33
MAX	39	39	38	40	44	46	46	48	48	33	31	34

Medidas Métricas - Metric Sizes

Unidad : Métrico
Unit : Metric

Código Code	Modelo Model	Boquilla - Collet			Tuerca ciega Nut	Llave Inglesa Spanner
		Rosca métrica Metric thread	Tubo de machuelo Pipe tap	Machuelo sincronizado de OSG OSG synchro tap		
2800 00001 ※※※	STC1- ※※※	FDC-09		FDC-09	HDP-09B	S-1L
2800 00001 ※※※	STC1- ※※※		ESC10		KDP-1916	S-1L
2800 00002 ※※※	STC2- ※※※	FDC-16		FDC-16	HDP-16B	S-4L
2800 00002 ※※※	STC2- ※※※		ESC16		KDP-2825	S-4L

1. La medida del machuelo se insertará en " ※※※ ".
2. El adaptador STC viene por completo con boquilla y tuerca, pero la llave inglesa se vende por separado.
3. Favor de especificar si usa el machuelo sincronizado OSG.
Por ejemplo: STC1-M3-O

1. Tap size will be inserted in " ※※※ ".
2. STC adapter comes complete with collet and nut, but spanner is sold separately.
3. When using OSG synchro tap, please specify it.
Example : STC1-M3-O

STP Portaherramientas - STP Holder

Ejemplo para Ordenar - Ordering Example

HSK40A - STP1 - 80

Interfaz y diámetro de husillo	Medida del adaptador	L1
Shank size	Adapter size	L1

STC Adaptador - ATP Adapter

Ejemplo para Ordenar - Ordering Example

STC1 - M10 - ANSI

Medida	Medida de machuelo	ANSI,ISO,DIN,JIS
Size	Tap size	ANSI,ISO,DIN,JIS

WEN•B BILZ Adaptador de machuelo Tap Adapter

Ejemplo para Ordenar - Ordering Example

WEN1B - M10 - ANSI

Medida	Medida de machuelo	ANSI,ISO,DIN,JIS
Size	Tap size	ANSI,ISO,DIN,JIS

TP1

Quick Change Tapping Chuck

- La compresión fuerte permite el uso con machuelo incorporada.
- Strong compression allows use with rolled thread tap.

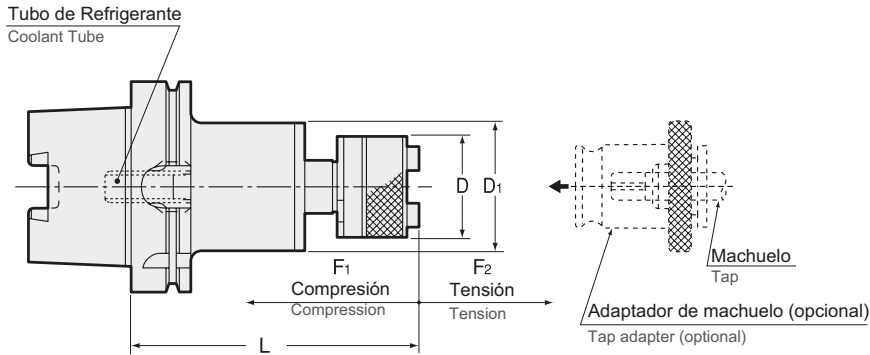

- Tubo de refrigerante incluido.
- Coolant tube is included.

⚠ Para conocer las medidas adecuadas del machuelo, consulte la tabla en la pág.485.
For capable tap sizes, please refer to P. 485 chart.

Medidas Métricas - Metric Sizes										Unidad : Métrico Unit : Metric
Código Code	Modelo Model	Medida de machuelo Tap Size	Medida del adaptador Adapter size	L	D	D1	Compensación axial Axial compensation		kg	
							F1	F2		
5460 13001113	HSK40A -TP1 -1 -113	M3 ~ M12,U1/4 ~ U7/16, PIPE (PT,PS,PF) 1/8	1	113	32	44	6	18	0.9	
5460 14001113	HSK50A -TP1 -1 -113	M3 ~ M12,U1/4 ~ U7/16, PIPE (PT,PS,PF) 1/8	1	113	32	44	6	18		
5460 14002139	-2 -139	M8 ~ M22,U3/8 ~ U7/8, PIPE (PT,PS,PF) 1/8 ~ 3/8	2	139	50	46	10	15		
5460 75001113	HSK63A -TP1 -1 -113-H	M3 ~ M12,U1/4 ~ U7/16, PIPE (PT,PS,PF) 1/8	1	113	32	44	6	18	1.4	
5460 15002139	-2 -139-H	M8 ~ M22,U3/8 ~ U7/8, PIPE (PT,PS,PF) 1/8 ~ 3/8	2	139	50	46	10	15	1.8	
5460 77001113	HSK100A -TP1 -1 -113-H	M3 ~ M12,U1/4 ~ U7/16, PIPE (PT,PS,PF) 1/8	1	113	32	44	6	18	2.7	
5460 77002139	-2 -139-H	M8 ~ M22,U3/8 ~ U7/8, PIPE (PT,PS,PF) 1/8 ~ 3/8	2	139	50	46	10	15	3.1	
5460 77003211	-3 -211-H	M16 ~ M38,U3/4 ~ 1-3/8, PIPE (PT,PS,PF) 3/8 ~ 1-1/8	3	211	72	62	20	20	5.2	

1. Para prevenir que el machuelo se rompa, use el adaptador del machuelo con un dispositivo seguro de torque.
2. El adaptador de machuelo se vende por separado

1. To prevent tap breakage, use tap adapter with safety torque device.
2. Tap adapter is sold separately.



Ejemplo para Ordenar - Ordering Example
HSK40A - TP1-1 - 139

Interfaz y diámetro de husillo
Shank size

Medida de adaptador
Adapter size

Longitud de proyección
Projection length(L)

Ejemplo para Ordenar - Ordering Example
HSK63A - TP1-1 - 113 - H

Interfaz y diámetro de husillo
Shank size

Medida de adaptador
Adapter size

Longitud de proyección
Projection length(L)

Barreno de Cambio Manual
Manual Clamp Hole

Tipo1
Type1

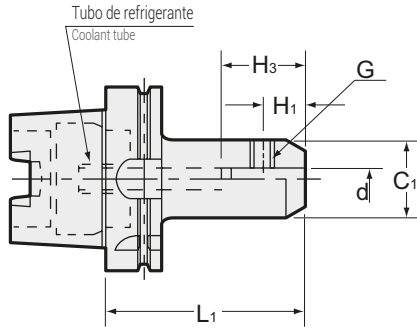

Tipo2
Type2

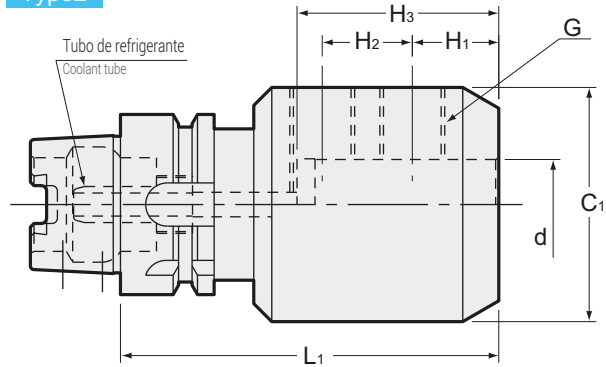

- Tubo de refrigerante incluido.
- Coolant tube is included.

Medida en Pulgadas - Inch Sizes

Unidad : Pulgadas
Unit : Inch

Código Code	Modelo Model	Tipo Type	d H6 (mm)	C1	L1	H1	H2	H3	G	kg
-	HSK40A -SLH -0250 -60	1	0.250	0.790	2.362	0.437	-	1.420	1/4-28 × 1/4	
-	HSK40A -SLH -0250 -105	1	0.250	0.790	4.134	0.437	-	1.420	1/4-28 × 1/4	
-	HSK40A -SLH -0313 -60	1	0.3125	0.870	2.362	0.437	-	1.420	5/16-24 × 1/4	
-	HSK40A -SLH -0313 -105	1	0.3125	0.870	4.134	0.437	-	1.420	5/16-24 × 1/4	
-	HSK40A -SLH -0375 -60	1	0.375	1.000	2.362	0.710	-	1.560	3/8-24 × 5/16	
-	HSK40A -SLH -0375 -105	1	0.375	1.000	4.134	0.710	-	1.560	3/8-24 × 5/16	
-	HSK40A -SLH -0438 -60	1	0.4375	1.380	2.362	0.710	-	1.770	7/16-20 × 3/8	
-	HSK40A -SLH -0438 -105	1	0.4375	1.380	4.134	0.710	-	1.770	7/16-20 × 3/8	
-	HSK40A -SLH -0500 -75	1	0.500	1.380	2.953	0.710	-	1.770	7/16-20 × 3/8	
-	HSK40A -SLH -0500 -105	1	0.500	1.380	4.134	0.710	-	1.770	7/16-20 × 3/8	
5420 13320075	HSK40A -SLH -0625 -75	2	0.625	1.650	2.953	0.700	-	1.890	9/16-18 × 1/2	0.6
-	HSK40A -SLH -0625 -105	2	0.625	1.650	4.134	0.700	-	1.890	9/16-18 × 1/2	
5420 23224075	HSK40A -SLH -0750 -75	2	0.750	1.750	2.953	0.74	-	2.020	5/8-18 × 1/2	0.6
-	HSK40A -SLH -0750 -135	2	0.750	1.750	5.315	0.74	-	2.020	5/8-18 × 1/2	
-	HSK40A -SLH -0875 -75	2	0.875	2.000	2.953	0.74	-	2.020	5/8-18 × 1/2	
-	HSK40A -SLH -0875 -135	2	0.875	2.000	5.315	0.74	-	2.020	5/8-18 × 1/2	
-	HSK63A -SLH -0250 -60	1	0.250	0.790	2.362	0.437	-	1.420	1/4-28 × 1/4	
-	HSK63A -SLH -0250 -105	1	0.250	0.790	4.134	0.437	-	1.420	1/4-28 × 1/4	
-	HSK63A -SLH -0313 -80	1	0.3125	0.870	3.150	0.437	-	1.420	5/16-24 × 1/4	
-	HSK63A -SLH -0313 -150	1	0.3125	0.870	5.906	0.437	-	1.420	5/16-24 × 1/4	
-	HSK63A -SLH -0375 -90	1	0.375	1.000	3.543	0.710	-	1.560	3/8-24 × 5/16	
-	HSK63A -SLH -0375 -150	1	0.375	1.000	5.906	0.710	-	1.560	3/8-24 × 5/16	
-	HSK63A -SLH -0438 -95	1	0.4375	1.380	3.740	0.710	-	1.770	7/16-20 × 3/8	
-	HSK63A -SLH -0438 -150	1	0.4375	1.380	5.906	0.710	-	1.770	7/16-20 × 3/8	
-	HSK63A -SLH -0500 -95	1	0.500	1.380	3.740	0.710	-	1.770	7/16-20 × 3/8	
-	HSK63A -SLH -0500 -150	1	0.500	1.380	5.906	0.710	-	1.770	7/16-20 × 3/8	
-	HSK63A -SLH -0625 -100	1	0.625	1.650	3.937	0.700	-	1.890	9/16-18 × 1/2	
-	HSK63A -SLH -0625 -150	1	0.625	1.650	5.906	0.700	-	1.890	9/16-18 × 1/2	
-	HSK63A -SLH -0750 -100	1	0.750	1.750	3.937	0.740	-	2.020	5/8-18 × 1/2	
-	HSK63A -SLH -0750 -150	1	0.750	1.750	5.906	0.740	-	2.020	5/8-18 × 1/2	
-	HSK63A -SLH -0875 -100	1	0.875	2.000	3.937	0.740	-	2.020	5/8-18 × 1/2	
-	HSK63A -SLH -0875 -150	1	0.875	2.000	5.906	0.740	-	2.020	5/8-18 × 1/2	
5420 15332150	HSK63A -SLH -1000 -100	2	1.000	2.360	3.937	0.860	-	2.270	3/4-16 × 11/16	2.9
-	HSK63A -SLH -1000 -150	2	1.000	2.360	5.906	0.860	-	2.270	3/4-16 × 11/16	
5420 15340100	HSK63A -SLH -1250 -100	2	1.250	2.650	3.937	0.860	-	2.270	3/4-16 × 11/16	2.9
-	HSK63A -SLH -1250 -150	2	1.250	2.650	5.906	0.860	-	2.270	3/4-16 × 11/16	
5420 15348100	HSK63A -SLH -1500 -100	2	1.500	2.990	3.937	1.181	-	2.717	3/4-16 × 11/16	2.3
-	HSK63A -SLH -1500 -150	2	1.500	2.990	5.906	1.181	-	2.717	3/4-16 × 11/16	

El código de artículo con "-" es un artículo semiestándar.
Item code with "-" is semi standard item.

Ejemplo para Ordenar - Ordering Example

HSK40A - SLH - 0250 - 65

Interfaz y diámetro de husillo

Diámetro Interno

Longitud de proyección

Shank size

I.D. (d)

Projection length (L)

Medida en Pulgadas - Inch Sizes

Unidad : Pulgadas
Unit : Inch

Código Code	Modelo Model	Tipo Type	d H6 (mm)	C1	L1	H1	H2	H3	G	kg
-	HSK100A -SLH -0250 -75	1	0.250	0.790	2.953	0.437	-	1.420	1/4-28 × 1/4	
-	-135	1	0.250	0.790	5.315	0.437	-	1.420	1/4-28 × 1/4	
-	HSK100A -SLH -0313 -75	1	0.3125	0.870	2.953	0.437	-	1.420	5/16-24 × 1/4	
-	-135	1	0.3125	0.870	5.315	0.437	-	1.420	5/16-24 × 1/4	
-	HSK100A -SLH -0375 -90	1	0.375	1.000	3.543	0.710	-	1.560	3/8-24 × 5/16	
-	-150	1	0.375	1.000	5.906	0.710	-	1.560	3/8-24 × 5/16	
-	HSK100A -SLH -0438 -100	1	0.4375	1.380	3.937	0.710	-	1.770	7/16-20 × 3/8	
-	-165	1	0.4375	1.380	6.496	0.710	-	1.770	7/16-20 × 3/8	
-	HSK100A -SLH -0500 -105	1	0.500	1.380	4.134	0.710	-	1.770	7/16-20 × 3/8	
-	-165	1	0.500	1.380	6.496	0.710	-	1.770	7/16-20 × 3/8	
-	HSK100A -SLH -0625 -110	1	0.625	1.650	4.331	0.700	-	1.890	9/16-18 × 1/2	
-	-165	1	0.625	1.650	6.496	0.700	-	1.890	9/16-18 × 1/2	
-	HSK100A -SLH -0750 -110	1	0.750	1.750	4.331	0.740	-	2.020	5/8-18 × 1/2	
-	-165	1	0.750	1.750	6.496	0.740	-	2.020	5/8-18 × 1/2	
-	HSK100A -SLH -0875 -110	1	0.875	2.000	4.331	0.740	-	2.020	5/8-18 × 1/2	
-	-165	1	0.875	2.000	6.496	0.740	-	2.020	5/8-18 × 1/2	
-	HSK100A -SLH -1000 -115	1	1.000	2.360	4.528	0.860	-	2.270	3/4-16 × 11/16	
-	-165	1	1.000	2.360	6.496	0.860	-	2.270	3/4-16 × 11/16	
-	HSK100A -SLH -1250 -120	1	1.250	2.650	4.724	0.860	-	2.270	3/4-16 × 11/16	
-	-165	1	1.250	2.650	6.496	0.860	-	2.270	3/4-16 × 11/16	
-	HSK100A -SLH -1500 -120	1	1.500	2.990	4.724	1.181	-	2.717	3/4-16 × 11/16	
-	-165	1	1.500	2.990	6.496	1.181	-	2.717	3/4-16 × 11/16	
5420 17364135	HSK100A -SLH -2000 -135	2	2.000	3.740	5.315	1.260	1.500	3.380	1-12 × 7/8	6.1
-	-180	2	2.000	3.740	7.087	1.260	1.500	3.380	1-12 × 7/8	
-	HSK100A -SLH -2500 -135	2	2.500	4.250	5.315	1.162	1.500	3.380	1-12 × 7/8	
-	-180	2	2.500	4.250	7.087	1.162	1.500	3.380	1-12 × 7/8	

El código de artículo con "-" es un artículo semiestándar.
Item code with - is semi standard item.

Ejemplo para Ordenar - Ordering Example

HSK40A - SLH - 0250 - 65

Interfaz y diámetro de husillo	Diámetro Interno	Longitud de proyección
Shank size	I.D. (d)	Projection length (L)

HSK-A

BT

CAT

AHO

HSK-A/E/F/C

HSK-T

C

UTS

Máquinas

Especializadas

Specialized

Machine

Equipo

Relacionado

Related

Equipment

Taladro de

Biselado & de

Casquillo

Bush &

Chamfering

Drill

Milling Chuck

Collet Holder

"R" Zero Holder

Hydraulic

Chuck

Shrink Fit

Tapping Chuck

Anchors

Function

Holder

HSK-E

HSK-F

HSK-C

Dimensions

SLA

Side Lock Holder

- Para herramienta de barra mandriladora de zanco recto con llave y cabeza de la barra recta con llave.
- For straight shank boring bar with flat and straight shank boring head with flat.

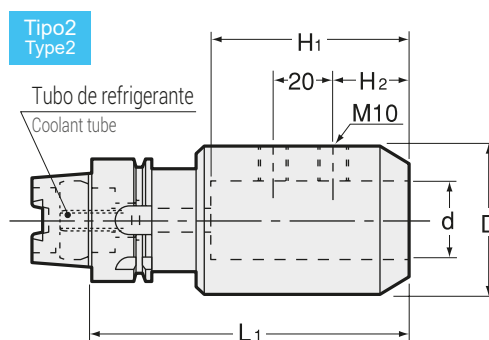
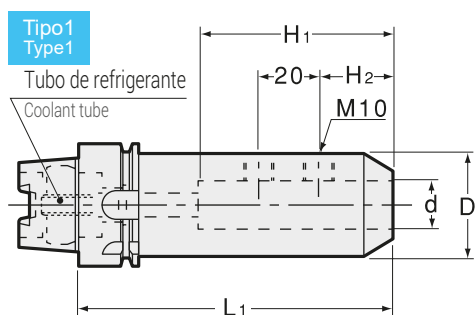

- Tubo de refrigerante incluido.
- Coolant tube is included.

- Tubo de refrigerante incluido.
- Coolant tube is included.

Medidas Métricas - Metric Sizes

Unidad : Métrico
Unit : Metric

Código Code	Modelo Model	Tipo Type	d	L1	D	H1	H2	kg
5420 13116090	HSK40A -SLA16 -90	2	16	90	40	65	25	
5420 13120090	HSK40A -SLA20 -90	2	20	90	40	65	25	
5420 13125105	HSK40A -SLA25 -105	2	25	105	46	65	25	0.9
5420 14116090	HSK50A -SLA16 -90	1	16	90	40	65	25	
5420 14120090	HSK50A -SLA20 -90	1	20	90	40	65	25	0.9
5420 14125105	HSK50A -SLA25 -105	2	25	105	46	65	25	1.1
5420 75120090	HSK63A -SLA20 -90-H	1	20	90	50	65	25	1.5
5420 75125105	HSK63A -SLA25 -105-H	1	25	105	50	65	25	1.6
5420 75132105	HSK63A -SLA32 -105-H	2	32	105	60	75	30	1.8
5420 77120105	HSK100A -SLA20 -105-H	1	20	105	50	65	25	3.0
5420 77125105	HSK100A -SLA25 -105-H	1	25	105	50	65	25	2.9
5420 77132120	HSK100A -SLA32 -120-H	1	32	120	60	75	30	3.6
5420 77142120	HSK100A -SLA42 -120-H	1	42	120	70	75	30	3.9

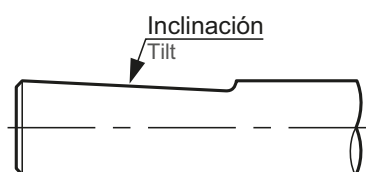

Favor de contactar a NT si la herramienta de corte se ha inclinado hasta quedar plana sobre el zanco.

El portaherramienta de la herramienta especial que va con esa inclinación puede fabricarse.

Please contact NT if the cutting tool has tilted flat on the shank.

Special tool holder that matches to the tilted flat can be manufactured.

Ejemplo para Ordenar - Ordering Example

HSK40A - SLA - 20 - 90

Interfaz y diámetro de husillo

Diámetro Interno

Longitud de proyección

Shank size

I.D. (d)

Projection length (L)

Ejemplo para Ordenar - Ordering Example

HSK63A - SLA 20 - 90 - H

Interfaz y diámetro de husillo

Diámetro Interno

Longitud de proyección

Barreno de Cambio Manual

Shank size

I.D.

Projection length

Manual clamp hole

SL2

Side Lock Holder

- Para acabado en fresa JIS con zanco recto y llave.
- For JIS straight shank endmill with flat.

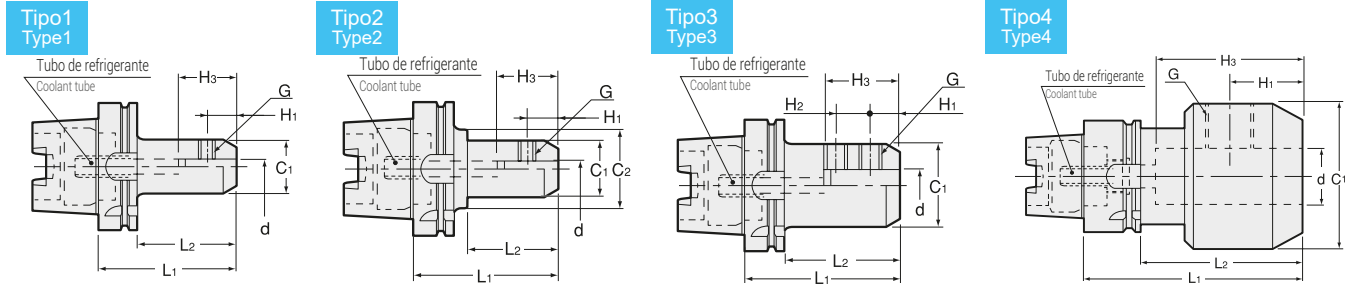

- Tubo de refrigerante incluido.
- Coolant tube is included.

Código Code	Modelo Model	Tipo Type	d	L1	L2	C1	C2	H1	H2	H3	G	kg	—
5420 13206060	HSK40A -SL2 -6 -60	1	6	60	40	25	—	18	—	36	M6		19,500
5420 13208060	-8 -60	1	8	60	40	28	—	18	—	36	M8		19,500
5420 13210060	-10 -60	4	10	60	40	35	—	20	—	40	M10	0.5	19,500
5420 13212075	-12 -75	4	12	75	55	42	—	22.5	—	45	M12		19,500
5420 13216075	-16 -75	4	16	75	55	42	—	24	—	48	M14		19,500
5420 13220075	-20 -75	4	20	75	55	42	—	25	—	50	M16	0.6	19,500
5420 14206060	HSK50A -SL2 -6 -60	1	6	60	34	25	—	18	—	36	M6		20,000
5420 14208060	-8 -60	1	8	60	34	28	—	18	—	36	M8		21,000
5420 14210065	-10 -65	1	10	65	39	35	—	20	—	40	M10	0.7	20,000
5420 14212075	-12 -75	1	12	75	49	42	—	22.5	—	45	M12	0.9	21,000
5420 14216075	-16 -75	1	16	75	49	42	—	24	—	48	M14	0.9	20,000
5420 14220090	-20 -90	1	20	90	64	42	—	25	—	50	M16	1.0	21,000
5420 75208080	HSK63A -SL2 -8 -80 -H	1	8	80	54	28	—	18	—	36	M8	0.9	21,000
5420 75208150	-150 -H	1	8	150	124	28	—	18	—	36	M8		22,000
5420 75210090	-10 -90 -H	1	10	90	64	35	—	20	—	40	M10	1.1	21,000
5420 75210150	-150 -H	1	10	150	124	35	—	20	—	40	M10	1.6	22,000
5420 75212095	-12 -95 -H	1	12	95	69	42	—	22.5	—	45	M12	1.4	21,000
5420 75212150	-150 -H	1	12	150	124	42	—	22.5	—	45	M12	1.9	22,000
5420 75216100	-16 -100 -H	1	16	100	74	48	—	24	—	48	M14	1.6	21,000
5420 75216150	-150 -H	1	16	150	124	48	—	24	—	48	M14	2.3	22,000
5420 75220100	-20 -100 -H	1	20	100	74	52	—	25	—	50	M16	1.8	21,000
5420 75220150	-150 -H	1	20	150	124	52	—	25	—	50	M16	2.5	22,000
5420 77208090	HSK100A -SL2 -8 -90 -H	2	8	90	49	28	50	18	—	36	M8		30,000
5420 77208165	-165 -H	2	8	165	124	28	50	18	—	36	M8	2.8	31,000
5420 77210100	-10 -100 -H	2	10	100	59	35	50	20	—	40	M10	2.6	30,000
5420 77210165	-165 -H	2	10	165	124	35	50	20	—	40	M10		31,000
5420 77212105	-12 -105 -H	1	12	105	76	42	—	22.5	—	45	M12	2.8	30,000
5420 77212165	-165 -H	1	12	165	136	42	—	22.5	—	45	M12	3.4	31,000
5420 77216110	-16 -110 -H	1	16	110	81	48	—	24	—	48	M14	3.1	30,000
5420 77216165	-165 -H	1	16	165	136	48	—	24	—	48	M14	3.8	31,000
5420 77220110	-20 -110 -H	1	20	110	81	52	—	25	—	50	M16	3.2	30,000
5420 77220165	-165 -H	1	20	165	136	52	—	25	—	50	M16		31,000
5420 77225115	-25 -115 -H	3	25	115	86	65	—	24	25	56	M18	4.0	30,000
5420 77225165	-165 -H	3	25	165	136	65	—	24	25	56	M18		31,000
5420 77232120	-32 -120 -H	3	32	120	91	72	—	24	28	60	M20	4.5	30,000
5420 77232165	-165 -H	3	32	165	136	72	—	24	28	60	M20		31,000

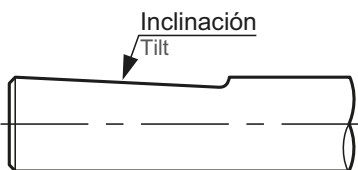

Favor de contactar a NT si la herramienta de corte se ha inclinado hasta quedar plana sobre el zanco. El portaherramienta de la herramienta especial que va con esa inclinación puede fabricarse. Please contact NT if the cutting tool has tilted flat on the shank. Special tool holder that matches to the tilted flat can be manufactured.

Ejemplo para Ordenar - Ordering Example

HSK63A - SL2 - 8 - 90

Interfaz y diámetro de husillo
Shank size

Diámetro Interno
I.D. (d)

Longitud de proyección
Projection length (L)

Ejemplo para Ordenar - Ordering Example

HSK100A - SL2 - 8 - 90 - H

Interfaz y diámetro de husillo
Shank size

Diámetro Interno
I.D.

Longitud de proyección
Projection length

Barreno de Cambio Manual
Manual clamp hole

SLD

Side Lock Holder

- Para uso con herramientas de corte de zanco recto con una cara plana en su circunferencia.
- For use with straight shank cutting tools with a flat and a flange.

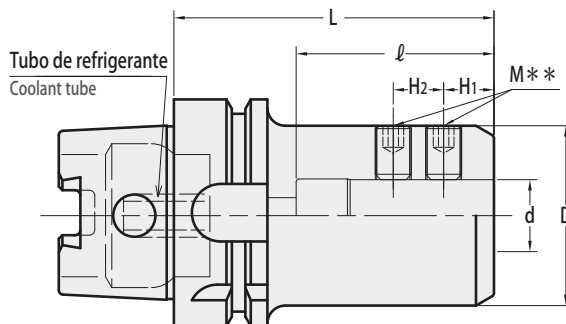
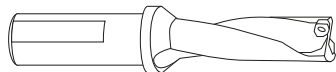

Código Code	Modelo Model	d	L	l	D	H1	H2	M	—
5420 75420090	HSK63A -SLD20 -90 -H	20	90	55	50	14	14	10	27,000
5420 75425090	-SLD25 -90 -H	25	90	60	55	15	20	14	28,000
5420 75432105	-SLD32 -105 -H	32	105	65	62	15	20	16	29,000
5420 75440120	-SLD40 -120 -H	40	120	75	70	15	25	16	35,000
5420 77420090	HSK100A -SLD20 -90 -H	20	90	55	50	14	14	10	35,000
5420 77425090	-SLD25 -90 -H	25	90	60	55	15	20	14	37,000
5420 77432105	-SLD32 -105 -H	32	105	65	62	15	20	16	37,000
5420 77440105	-SLD40 -105 -H	40	105	71	75	15	25	16	39,000
5420 77450135	-SLD50 -135 -H	50	135	85	80	15	25	16	47,000

HSK63A, HSK100A incluye barreno de cambio manual en el zanco.
 HSK63A, HSK100A have manual clamp holes in the shank.

Ejemplo para Ordenar - Ordering Example

HSK63A - SLD20 - 90 - H

Interfaz y diámetro de husillo Shank size	Diámetro Interno I.D.	Longitud de proyección Projection length	Barreno de Cambio Manual Manual clamp hole
--	--------------------------	---	---

- BT
- CAT
- AHO
- HSK-A/E/F/C
- HSK-T
- C
- UTS
- Máquinas Especializadas
Specialized Machine
- Equipo Relacionado
Related Equipment
- Taladro de Biselado & de Casquillo
Bush & Chamfering Drill
- Milling Chuck
- Collet Holder
- "R" Zero Holder
- Hydraulic Chuck
- Shrink Fit
- Tapping Chuck
- Anvils
- Function Holder
- HSK-E
- HSK-F
- HSK-C
- Dimensions

Face Mill Arbor (For Cutters With Oil Hole)

- El refrigerante fluye del refrentado de la locación central al cortador con el orificio para aceite.
- Coolant flows from the end face of centering location to cutter with oil hole.

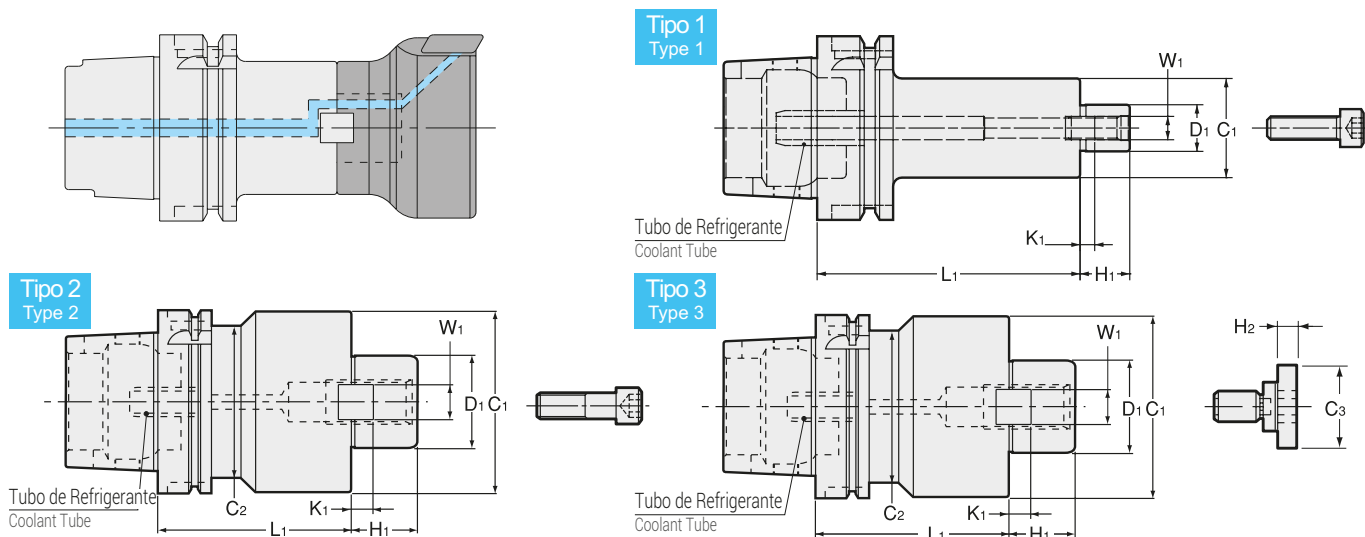

Medidas Métricas - Metric Sizes

Unidad : Métrico
Unit : Metric

Código Code	Modelo Model	Tipo Type	D1 (h6)	L1	C1	C2	H1	W1	K1	C3	H2	—	El perno de sujeción Clamp Bolt
5350 13616060	HSK40A -FMH16A -34 -60	1	16	60	34	—	17	8	5	—	—	21,700	M8
5350 13622060	-FMH22A -47 -60	2	22	60	47	34	18	10	5	—	—	21,700	M10
5350 13623060	-FMH22.225A -47 -60	2	22.225	60	47	34	17	8	3.5	—	—	21,700	M10
5350 13625060	-FMH25.4A -60 -60	2	25.4	60	60	34	22	9.5	5	—	—	21,900	M12
5350 13627060	-FMH27A -60 -60	2	27	60	60	34	20	12	6	—	—	21,900	M12
5350 14616060	HSK50A -FMH16A -34 -60	1	16	60	34	—	17	8	5	—	—	21,700	M8
5350 14622060	-FMH22A -47 -60	2	22	60	47	42	18	10	5	—	—	21,700	M10
5350 14623060	-FMH22.225A -47 -60	2	22.225	60	47	42	17	8	3.5	—	—	21,900	M10
5350 14625060	-FMH25.4A -60 -60	2	25.4	60	60	42	22	9.5	5	—	—	21,900	M12
5350 14627060	-FMH27A -60 -60	2	27	60	60	42	20	12	6	—	—	21,900	M12
5350 15616060	HSK63A -FMH16A -34 -60 -H	1	16	60	34	—	17	8	5	—	—	21,700	M8
5350 15616090	-90 -H	1	16	90	34	—	17	8	5	—	—	21,900	M8
5350 15616120	-120 -H	1	16	120	34	—	17	8	5	—	—	22,300	M8
5350 15622060	-FMH22A -47 -60 -H	1	22	60	47	—	18	10	5	—	—	26,200	M10
5350 15622090	-90 -H	1	22	90	47	—	18	10	5	—	—	26,600	M10
5350 15622120	-120 -H	1	22	120	47	—	18	10	5	—	—	26,800	M10
5350 15722060	-60 -60 -H	2	22	60	60	53	18	10	5	—	—	26,200	M10
5350 15722090	-90 -H	2	22	90	60	53	18	10	5	—	—	26,600	M10
5350 15722120	-120 -H	2	22	120	60	53	18	10	5	—	—	26,800	M10
5350 15623060	-FMH22.225A -47 -60 -H	1	22.225	60	47	—	17	8	3.5	—	—	26,200	M10
5350 15623090	-90 -H	1	22.225	90	47	—	17	8	3.5	—	—	26,600	M10
5350 15623120	-120 -H	1	22.225	120	47	—	17	8	3.5	—	—	26,800	M10
5350 15723060	-60 -60 -H	2	22.225	60	60	53	17	8	3.5	—	—	26,200	M10
5350 15723090	-90 -H	2	22.225	90	60	53	17	8	3.5	—	—	26,600	M10
5350 15723120	-120 -H	2	22.225	120	60	53	17	8	3.5	—	—	26,800	M10
5350 15625060	-FMH25.4A -60 -60 -H	2	25.4	60	60	53	22	9.5	5	—	—	26,800	M12
5350 15625090	-90 -H	2	25.4	90	60	53	22	9.5	5	—	—	27,000	M12
5350 15625120	-120 -H	2	25.4	120	60	53	22	9.5	5	—	—	27,400	M12
5350 15627060	-FMH27A -60 -60 -H	2	27	60	60	53	20	12	6	—	—	26,800	M12
5350 15627090	-90 -H	2	27	90	60	53	20	12	6	—	—	27,000	M12
5350 15627120	-120 -H	2	27	120	60	53	20	12	6	—	—	27,400	M12
5350 15727060	-76 -60 -H	2	27	60	76	53	20	12	6	—	—	26,800	M12
5350 15727090	-90 -H	2	27	90	76	53	20	12	6	—	—	27,000	M12
5350 15727120	-120 -H	2	27	120	76	53	20	12	6	—	—	27,400	M12
5350 15631060	-FMH31.75A -76 -60 -H	2	31.75	60	76	53	30	12.7	7	—	—	26,800	M16
5350 15631090	-90 -H	2	31.75	90	76	53	30	12.7	7	—	—	27,000	M16
5350 15631120	-120 -H	2	31.75	120	76	53	30	12.7	7	—	—	27,400	M16
5350 15731060	-96 -60 -H	2	31.75	60	96	53	30	12.7	7	—	—	26,800	M16
5350 15731090	-90 -H	2	31.75	90	96	53	30	12.7	7	—	—	27,000	M16
5350 15731120	-120 -H	2	31.75	120	96	53	30	12.7	7	—	—	27,400	M16
5350 15632060	-FMH32A -96 -60 -H	2	32	60	96	53	22	14	7	—	—	29,400	M16
5350 15632090	-90 -H	2	32	90	96	53	22	14	7	—	—	29,700	M16
5350 15632120	-120 -H	2	32	120	96	53	22	14	7	—	—	30,100	M16

Medidas Métricas - Metric Sizes

Unidad : Métrico
Unit : Metric

Código Code	Modelo Model	Tipo Type	D1 (h6)	L1	C1	C2	H1	W1	K1	C3	H2	—	El perno de sujeción Clamp Bolt			
5350 17616075	HSK100A -FMH16A	-34	-H	1	16	75	34	—	17	8	5	—	36,400	M8		
5350 17616105		-105	-H	1	16	105	34	—	17	8	5	—	36,700			
5350 17616135		-135	-H	1	16	135	34	—	17	8	5	—	37,200			
5350 17616150		-150	-H	1	16	150	34	—	17	8	5	—	39,200			
5350 17616200		-200	-H	1	16	200	34	—	17	8	5	—	45,200			
5350 17616250	-250	-H	1	16	250	34	—	17	8	5	—	51,400				
5350 17622075	-FMH22A	-47	-H	1	22	75	47	—	18	10	5	—	37,200	M10		
5350 17622105		-105	-H	1	22	105	47	—	18	10	5	—	37,600			
5350 17622135		-135	-H	1	22	135	47	—	18	10	5	—	38,000			
5350 17622150		-150	-H	1	22	150	47	—	18	10	5	—	40,100			
5350 17622200		-200	-H	1	22	200	47	—	18	10	5	—	46,200			
5350 17622250	-250	-H	1	22	250	47	—	18	10	5	—	52,500				
5350 17722075	-60	-75	-H	1	22	75	60	—	18	10	5	—	37,200	M10		
5350 17722105		-105	-H	1	22	105	60	—	18	10	5	—	37,600			
5350 17722135		-135	-H	1	22	135	60	—	18	10	5	—	38,000			
5350 17722150		-150	-H	1	22	150	60	—	18	10	5	—	40,100			
5350 17722200		-200	-H	1	22	200	60	—	18	10	5	—	46,200			
5350 17722250	-250	-H	1	22	250	60	—	18	10	5	—	52,500				
5350 17623075	-FMH22.225A	-47	-H	1	22.225	75	47	—	17	8	3.5	—	37,200	M10		
5350 17623105		-105	-H	1	22.225	105	47	—	17	8	3.5	—	37,600			
5350 17623135		-135	-H	1	22.225	135	47	—	17	8	3.5	—	38,000			
5350 17623150		-150	-H	1	22.225	150	47	—	17	8	3.5	—	40,100			
5350 17623200		-200	-H	1	22.225	200	47	—	17	8	3.5	—	46,200			
5350 17623250	-250	-H	1	22.225	250	47	—	17	8	3.5	—	52,500				
5350 17723075	-60	-75	-H	1	22.225	75	60	—	17	8	3.5	—	37,200	M10		
5350 17723105		-105	-H	1	22.225	105	60	—	17	8	3.5	—	37,600			
5350 17723135		-135	-H	1	22.225	135	60	—	17	8	3.5	—	38,000			
5350 17723150		-150	-H	1	22.225	150	60	—	17	8	3.5	—	40,100			
5350 17723200		-200	-H	1	22.225	200	60	—	17	8	3.5	—	46,200			
5350 17723250	-250	-H	1	22.225	250	60	—	17	8	3.5	—	52,500				
5350 17625075	-FMH25.4A	-60	-H	1	25.4	75	60	—	22	9.5	5	—	37,200	M12		
5350 17625105		-105	-H	1	25.4	105	60	—	22	9.5	5	—	37,600			
5350 17625135		-135	-H	1	25.4	135	60	—	22	9.5	5	—	38,000			
5350 17625150		-150	-H	1	25.4	150	60	—	22	9.5	5	—	42,100			
5350 17625200		-200	-H	1	25.4	200	60	—	22	9.5	5	—	48,500			
5350 17627075	-FMH27A	-60	-H	1	27	75	60	—	20	12	6	—	37,200	M12		
5350 17627105		-105	-H	1	27	105	60	—	20	12	6	—	37,600			
5350 17627135		-135	-H	1	27	135	60	—	20	12	6	—	38,000			
5350 17627150		-150	-H	1	27	150	60	—	20	12	6	—	42,100			
5350 17627200		-200	-H	1	27	200	60	—	20	12	6	—	48,500			
5350 17727075	-76	-75	-H	1	27	75	76	—	20	12	6	—	37,200	M12		
5350 17727105		-105	-H	1	27	105	76	—	20	12	6	—	37,600			
5350 17727135		-135	-H	1	27	135	76	—	20	12	6	—	38,000			
5350 17727150		-150	-H	1	27	150	76	—	20	12	6	—	42,100			
5350 17727200		-200	-H	1	27	200	76	—	20	12	6	—	48,500			
5350 17631075	-FMH31.75A	-76	-H	1	31.75	75	76	—	30	12.7	7	—	37,200	M16		
5350 17631105		-105	-H	1	31.75	105	76	—	30	12.7	7	—	37,600			
5350 17631135		-135	-H	1	31.75	135	76	—	30	12.7	7	—	38,000			
5350 17631150		-150	-H	1	31.75	150	76	—	30	12.7	7	—	45,600			
5350 17631200		-200	-H	1	31.75	200	76	—	30	12.7	7	—	51,600			
5350 17731075	-96	-75	-H	2	31.75	75	96	85	30	12.7	7	—	37,200	M16		
5350 17731105		-105	-H	2	31.75	105	96	85	30	12.7	7	—	37,600			
5350 17731135		-135	-H	2	31.75	135	96	85	30	12.7	7	—	38,000			
5350 17731150		-150	-H	2	31.75	150	96	85	30	12.7	7	—	45,600			
5350 17731200		-200	-H	2	31.75	200	96	85	30	12.7	7	—	51,600			
5350 17632075	-FMH32A	-96	-H	2	32	75	96	85	22	14	7	—	37,200	M16		
5350 17632105		-105	-H	2	32	105	96	85	22	14	7	—	37,600			
5350 17632135		-135	-H	2	32	135	96	85	22	14	7	—	38,000			
5350 17638075		-FMH38.1A	-80	-H	3	38.1	75	80	80	34	15.9	9	50		14	37,200
5350 17638105			-105	-H	3	38.1	105	80	80	34	15.9	9	50		14	37,600
5350 17638135	-135		-H	3	38.1	135	80	80	34	15.9	9	50	14	38,000		
5350 17738075	-100		-75	-H	3	38.1	75	100	85	34	15.9	9	50	14	37,200	
5350 17738105			-105	-H	3	38.1	105	100	85	34	15.9	9	50	14	37,600	
5350 17738135		-135	-H	3	38.1	135	100	85	34	15.9	9	50	14	38,000		
5350 17640075		-FMH40A	-100	-H	3	40	75	100	85	26	16	8.5	50	14	37,200	
5350 17640105			-105	-H	3	40	105	100	85	26	16	8.5	50	14	37,600	
5350 17640135	-135		-H	3	40	135	100	85	26	16	8.5	50	14	38,000		
5350 17650075	-FMH50.8A		-100	-H	3	50.8	75	100	85	36	19.05	10	65	14	37,200	
5350 17650105			-105	-H	3	50.8	105	100	85	36	19.05	10	65	14	37,600	
5350 17650135		-135	-H	3	50.8	135	100	85	36	19.05	10	65	14	38,000		

Incluye el perno de sujeción.
Clamp bolt is Included.

Ejemplo para Ordenar - Ordering Example

Sin barreno de cambio manual (HSK40A~HSK100A)

Without manual clamping hole (HSK40A~HSK100A)

HSK50A - FMH 16 A - 34 - 60

Interfaz y diámetro de husillo	D1	C1	Longitud de proyección
Shank size	D1	C1	Projection length

Ejemplo para Ordenar - Ordering Example

Con barreno de cambio manual (HSK63A, HSK100A)

With manual clamping hole (HSK63A, HSK100A)

HSK63A - FMH 16 A - 34 - 60 - H

Interfaz y diámetro de husillo	D1	C1	Longitud de proyección	Barreno de Cambio Manual
Shank size	D1	C1	Projection length	With manual clamping hole



Face Mill Arbor

- Para fresa JIS B4113.
- For JIS B4113 face mill.

Tipo 1 Type 1

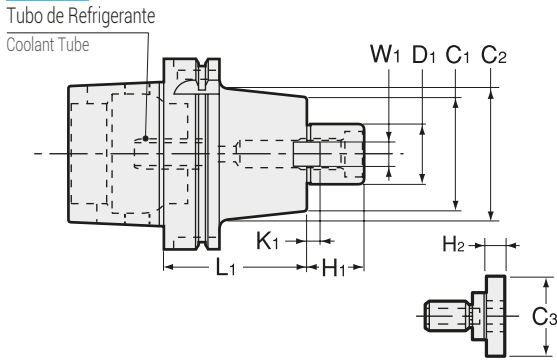

Tipo 2 Type 2

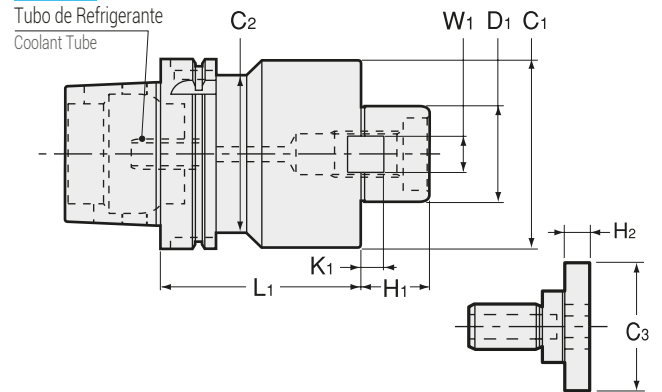

Medidas Métricas - Metric Sizes

Unidad : Métrico
Unit : Metric

Código Code	Modelo Model	Tipo Type	D1	L1	H1	C1	C2	W1	K1	C3	H2	kg	—	El perno de sujeción Clamp Bolt	Ejemplo del diá. de cortador Cutter dia. Example
5350 13019060	HSK40A -FMA19.05A -60	2	19.05	60	16	45	33.5	8	3.5	22	9	0.7	15,600	MBA-M10-19.05	—
5350 13025060	-FMA25.4A -60	2	25.4	60	22	50	34	9.5	5	33	10	0.7	15,600	MBA-M12	80
5350 14025060	HSK50A -FMA25.4A -60	2	25.4	60	22	50	42	9.5	5	33	10	0.9	17,000	MBA-M12	80
5350 15019060	HSK63A -FMA19.05A -60 -H	1	19.05	60	16	45	—	8	3.5	22	9	1.1	20,000	MBA-M10-19.05	—
5350 15019090	-90 -H	1	19.05	90	16	45	—	8	3.5	22	9	1.3	20,000		
5350 15025060	-FMA25.4A -60 -H	1	25.4	60	22	50	50	9.5	5	33	10	1.3	20,000		
5350 15025090	-90 -H	1	25.4	90	22	50	50	9.5	5	33	10	1.9	21,000	MBA-M12	80
5350 15025120	-120 -H	1	25.4	120	22	50	50	9.5	5	33	10	2.3	21,000		
5350 15031060	-FMA31.75A -60 -H	2	31.75	60	30	60	53	12.7	7	40	10	1.7	20,000		
5350 15031090	-90 -H	2	31.75	90	30	60	53	12.7	7	40	10	2.5	21,000	MBA-M16	100
5350 15031120	-120 -H	2	31.75	120	30	60	53	12.7	7	40	10	3.3	21,000		
5350 15038060	-FMA38.1A -60 -H	2	38.1	60	34	80	48	15.9	9	50	14	2.1	23,000		
5350 15038090	-90 -H	2	38.1	90	34	80	53	15.9	9	50	14	3.0	24,000	MBA-M20	125
5350 15038120	-120 -H	2	38.1	120	34	80	53	15.9	9	50	14	4.4	24,000		
5350 17025075	HSK100A -FMA25.4A -75 -H	1	25.4	75	22	50	70	9.5	5	33	10	3.2	29,000		
5350 17025105	-105 -H	1	25.4	105	22	50	70	9.5	5	33	10	3.9	31,000	MBA-M12	80
5350 17025135	-135 -H	1	25.4	135	22	50	70	9.5	5	33	10	4.6	33,000		
5350 17031075	-FMA31.75A -75 -H	1	31.75	75	30	60	70	12.7	7	40	10	3.5	29,000		
5350 17031105	-105 -H	1	31.75	105	30	60	70	12.7	7	40	10	4.3	31,000	MBA-M16	100
5350 17031135	-135 -H	1	31.75	135	30	60	70	12.7	7	40	10	5.1	33,000		
5350 17038075	-FMA38.1A -75 -H	1	38.1	75	34	80	80	15.9	9	50	14	4.4	29,000		
5350 17038105	-105 -H	1	38.1	105	34	80	80	15.9	9	50	14	5.7	31,000	MBA-M20	125
5350 17038135	-135 -H	1	38.1	135	34	80	80	15.9	9	50	14	7.0	33,000		
5350 17050075	-FMA50.8A -75 -H	2	50.8	75	36	99	83	19.05	10	65	14	5.7	29,000		
5350 17050105	-105 -H	2	50.8	105	36	99	83	19.05	10	65	14	7.7	31,000	MBA-M24	150
5350 17050135	-135 -H	2	50.8	135	36	99	83	19.05	10	65	14	9.7	33,000		

Incluye el perno de sujeción.
Clamp bolt is Included.

Ejemplo para Ordenar - Ordering Example

HSK50A - FMA 25.4 A - 60

Interfaz y diámetro de husillo Shank size	D1	Longitud de proyección Projection length
	D1	

Ejemplo para Ordenar - Ordering Example

HSK63A - FMA 25.4 A - 60 - H

Interfaz y diámetro de husillo Shank size	D1	Longitud de proyección Projection length	Barreno de Cambio Manual With manual clamping hole
	D1		

FMB-A

Face Mill Arbor

- Para el cortador de apoyo y la fresa SANDVIK T-MAX.
- For SANDVIK T-MAX face mill and shoulder cutter.

Tipo1
Type1

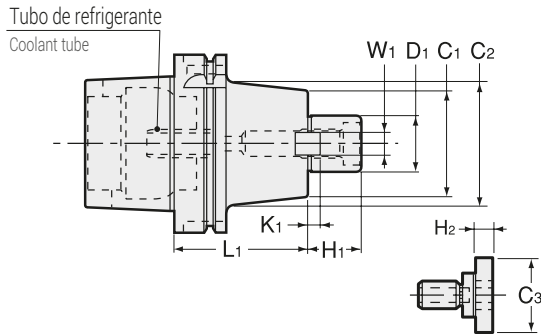

Tipo2
Type2

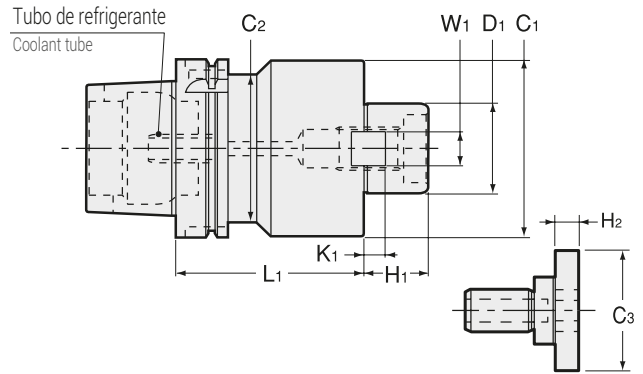

- Tubo de refrigerante incluido.
- Coolant tube is included.

Medidas Métricas - Metric Sizes

Unidad : Métrico
Unit : Metric

Código Code	Modelo Model	Tipo Type	D1	L1	H1	C1	C2	W1	K1	C3	H2	-	El perno de sujeción Clamp Bolt	Ejemplo del diámetro de cortador Cutter dia. Example
5350 13125060	HSK40A -FMB25.4A -60	2	25.4	60	26	80	34	9.5	5	33	10	15,600	MBA-M12	80
5350 13127060	-FMB27A -60	2	27	60	26	80	34	12	6	33	10	15,600	MBA-M12	80
5350 14125060	HSK50A -FMB25.4A -60	2	25.4	60	26	80	42	9.5	5	33	10	18,000	MBA-M12	80
5350 14127060	-FMB27A -60	2	27	60	26	80	42	12	6	33	10	18,000	MBA-M12	80
5350 15125060	HSK63A -FMB25.4A -60 -H	2	25.4	60	26	80	53	9.5	5	33	10	19,500	MBA-M12	80
5350 15127060	-FMB27A -60 -H	2	27	60	26	80	53	12	6	33	10	19,500	MBA-M12	80
5350 15138060	-FMB38.1A -60 -H	2	38.1	60	26	85	48	15.9	9	50	14	23,400	MBA-M20	100 125
5350 17125090	HSK100A -FMB25.4A -90 -H	1	25.4	90	26	80	80	9.5	5	33	10	29,900	MBA-M12	80
5350 17127090	-FMB27A -90 -H	1	27	90	26	80	80	12	6	33	10	29,900	MBA-M12	80
5350 17138105	-FMB38.1A -105 -H	1	38.1	105	26	85	85	15.9	9	50	14	32,500	MBA-M20	100 125

Incluye el perno de sujeción.
Clamp bolt is Included.

Ejemplo para Ordenar - Ordering Example

HSK40A - FMB 25.4A - 60

Interfaz y diámetro de husillo Shank size	Diámetro Interno D1	Longitud de proyección Projection length (L)

Ejemplo para Ordenar - Ordering Example

HSK63A - FMB - 25.4A - 60 - H

Interfaz y diámetro de husillo Shank size	Diámetro Interno I.D.	Longitud de proyección Projection length	Barreno de Cambio Manual Manual clamp hole

Face Mill Arbor

- Para la fresa de apoyo SANDVIK T-MAX.
- For SANDVIK T-MAX shoulder face mill.

Tipo1
Type1

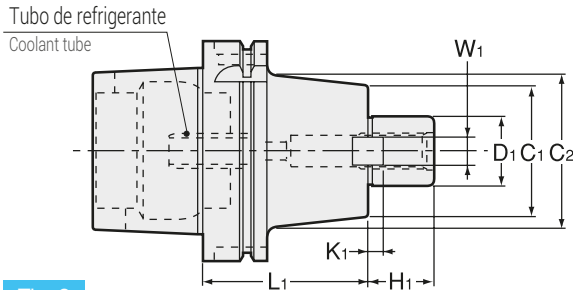

Tipo2
Type2

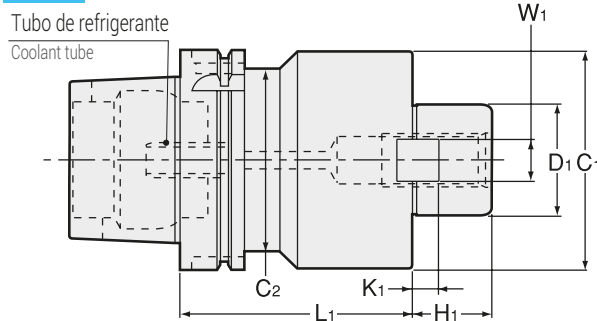

- Tubo de refrigerante incluido.
- Coolant tube is included.

Medidas Métricas - Metric Sizes

Unidad : Métrico
Unit : Metric

Código Code	Modelo Model	Tipo Type	D1	L1	H1	C1	C2	W1	K1	kg	—	El perno de sujeción Clamp Bolt (JIS B1176)	Ejemplo del diá. de cortador Cutter dia. Example
5350 13222045	HSK40A -FMC22A -45	2	22	45	18	45	31	10	5		15,600	M10	50 63
5350 13225060	-FMC25.4A -60	2	25.4	60	20	70	34	9.5	5		15,600	M12	80
5350 14222060	HSK50A -FMC22A -60	2	22	60	18	45	42	10	5		18,000	M10	50 63
5350 14225060	-FMC25.4A -60	2	25.4	60	20	70	42	9.5	5		18,000	M12	80
5350 15222060	HSK63A -FMC22A -60 -H	1	22	60	18	45	45	10	5	1.1	19,500	M10	50 63
5350 15225060	-FMC25.4A -60 -H	2	25.4	60	20	70	53	9.5	5		19,500	M12	80
5350 15227060	-FMC27A -60 -H	2	27	60	20	70	53	12	6	1.6	19,500	M12	80
5350 15238060	-FMC38.1A -60 -H	2	38.1	60	22	85	48	15.9	7		19,500	M16	100
5350 17222090	HSK100A -FMC22A -90 -H	1	22	90	18	45	85	10	5	3.7	28,600	M10	50 63
5350 17225090	-FMC25.4A -90 -H	1	25.4	90	20	70	85	9.5	5		29,900	M12	80
5350 17227090	-FMC27A -90 -H	1	27	90	20	70	85	12	6		29,900	M12	80
5350 17238105	-FMC38.1A -105 -H	1	38.1	105	22	85	85	15.9	7		33,800	M16	100

Incluye el perno de sujeción.
Clamp bolt is Included.

Ejemplo para Ordenar - Ordering Example

HSK40A - FMC 22A - 45
 Interfaz y diámetro de husillo → Shank size
 Diámetro Interno → D1
 Longitud de proyección → Projection length (L)

Ejemplo para Ordenar - Ordering Example

HSK63A - FMC - 22A - 60 - H
 Interfaz y diámetro de husillo → Shank size
 Diámetro Interno → I.D.
 Longitud de proyección → Projection length
 Barreno de Cambio Manual → Manual clamp hole

Side Cutter Arbor

- Para cortador lateral JIS y sierra metálica.
- For JIS side cutter and metal saw.

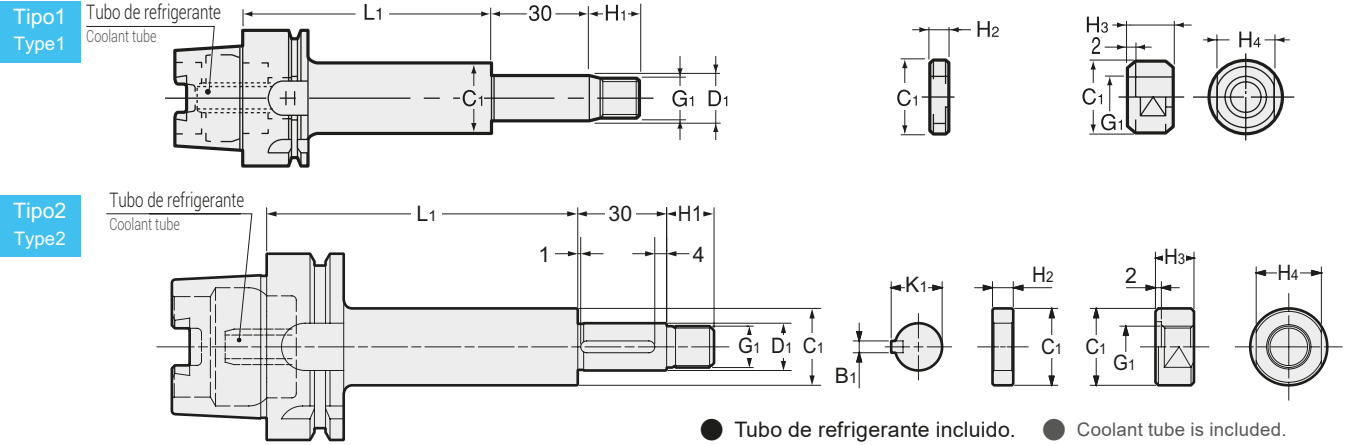

● Tubo de refrigerante incluido. ● Coolant tube is included.

Medidas Métricas - Metric Sizes

Unidad : Métrico
Unit : Metric

Código Code	Modelo Model	Tipo Type	D1 (h6)	L1	C1	G1	H1	B1	K1	H2	H3	H4	kg	Ejemplo del diá. de cortador Cutter dia. Example
5540 13013075	HSK40A -SCA13 -75	1	13	75	20	M12 × 1.25	15	—	—	3,5,7,8,10,12	12	17		50
5540 13016075	HSK40A -SCA16 -75	2	16	75	26	M14 × 1.5	16	4	17.2	3,5,7,8,10,12	13	22		50 ~ 63
5540 13022075	HSK40A -SCA22 -75	2	22	75	34	M20 × 1.5	21	6	23.6	3,5,7,8,10,12	18	30		60 ~ 125
5540 13112075	HSK40A -SCA12.7 -75	1	12.7	75	20	M12 × 1.25	15	—	—	3,5,7,8,10,12	12	17		50
5540 13115075	HSK40A -SCA15.875 -75	2	15.875	75	26	M14 × 1.5	16	3.18	17.42	3,5,7,8,10,12	13	22		50 ~ 63
5540 13122075	HSK40A -SCA22.225 -75	2	22.225	75	34	M20 × 1.5	21	3.18	23.82	3,5,7,8,10,12	18	30		60 ~ 125
5540 14013075	HSK50A -SCA13 -75	1	13	75	20	M12 × 1.25	15	—	—	3,5,7,8,10,12	12	17		50
5540 14016075	HSK50A -SCA16 -75	2	16	75	26	M14 × 1.5	16	4	17.2	3,5,7,8,10,12	13	22		50 ~ 63
5540 14022075	HSK50A -SCA22 -75	2	22	75	34	M20 × 1.5	21	6	23.6	3,5,7,8,10,12	18	30	1.2	60 ~ 125
5540 14112075	HSK50A -SCA12.7 -75	1	12.7	75	20	M12 × 1.25	15	—	—	3,5,7,8,10,12	12	17		50
5540 14115075	HSK50A -SCA15.875 -75	2	15.875	75	26	M14 × 1.5	16	3.18	17.42	3,5,7,8,10,12	13	22		50 ~ 63
5540 14122075	HSK50A -SCA22.225 -75	2	22.225	75	34	M20 × 1.5	21	3.18	23.82	3,5,7,8,10,12	18	30		60 ~ 125
5540 75013060	HSK63A -SCA13 -60-H	1	13	60	20	M12 × 1.25	15	—	—	3,5,7,8,10,12	12	17	1.0	50
5540 75013090	HSK63A -SCA13 -90-H	1	13	90	20	M12 × 1.25	15	—	—	3,5,7,8,10,12	12	17	1.0	50
5540 75016075	HSK63A -SCA16 -75-H	2	16	75	26	M14 × 1.5	16	4	17.2	3,5,7,8,10,12	13	22	1.4	50 ~ 63
5540 75016105	HSK63A -SCA16 -105-H	2	16	105	26	M14 × 1.5	16	4	17.2	3,5,7,8,10,12	13	22	1.5	50 ~ 63
5540 75022075	HSK63A -SCA22 -75-H	2	22	75	34	M20 × 1.5	21	6	23.6	3,5,7,8,10,12	18	30	1.8	60 ~ 125
5540 75022120	HSK63A -SCA22 -120-H	2	22	120	34	M20 × 1.5	21	6	23.6	3,5,7,8,10,12	18	30	1.8	60 ~ 125
5540 75027075	HSK63A -SCA27 -75-H	2	27	75	40	M24 × 2	25	7	29	3,5,7,8,10,12	21	32	2.0	75 ~ 100
5540 75027120	HSK63A -SCA27 -120-H	2	27	120	40	M24 × 2	25	7	29	3,5,7,8,10,12	21	32	2.4	75 ~ 100
5540 75032090	HSK63A -SCA32 -90-H	2	32	90	46	M30 × 2	30	8	34	3,5,7,8,10,12	26	41	2.4	100 ~ 250
5540 77013075	HSK100A -SCA13 -75-H	1	13	75	20	M12 × 1.25	15	—	—	3,5,7,8,10,12	12	17	4.3	50
5540 77013105	HSK100A -SCA13 -105-H	1	13	105	20	M12 × 1.25	15	—	—	3,5,7,8,10,12	12	17	4.4	50
5540 77016090	HSK100A -SCA16 -90-H	2	16	90	26	M14 × 1.5	16	4	17.2	3,5,7,8,10,12	13	22	4.2	50 ~ 63
5540 77016120	HSK100A -SCA16 -120-H	2	16	120	26	M14 × 1.5	16	4	17.2	3,5,7,8,10,12	13	22	4.4	50 ~ 63
5540 77022090	HSK100A -SCA22 -90-H	2	22	90	34	M20 × 1.5	21	6	23.6	3,5,7,8,10,12	18	30	4.4	60 ~ 125
5540 77022135	HSK100A -SCA22 -135-H	2	22	135	34	M20 × 1.5	21	6	23.6	3,5,7,8,10,12	18	30	4.7	60 ~ 125
5540 77027090	HSK100A -SCA27 -90-H	2	27	90	40	M24 × 2	25	7	29	3,5,7,8,10,12	21	32	4.5	75 ~ 100
5540 77027135	HSK100A -SCA27 -135-H	2	27	135	40	M24 × 2	25	7	29	3,5,7,8,10,12	21	32	4.9	75 ~ 100
5540 77032090	HSK100A -SCA32 -90-H	2	32	90	46	M30 × 2	30	8	34	3,5,7,8,10,12	26	41	4.7	100 ~ 250
5540 77032135	HSK100A -SCA32 -135-H	2	32	135	46	M30 × 2	30	8	34	3,5,7,8,10,12	26	41	5.2	100 ~ 250
5540 77040090	HSK100A -SCA40 -90-H	2	40	90	55	M36 × 3	36	10	42.5	3,5,7,8,10,12	31	46	4.9	150 ~ 315
5540 77040135	HSK100A -SCA40 -135-H	2	40	135	55	M36 × 3	36	10	42.5	3,5,7,8,10,12	31	46	5.9	150 ~ 315

Incluye una tuerca de sujeción y espaciadores (en tamaño 3, 5, 7, 8, 10 y 12/ uno de cada uno). Ordering Example
One clamp nut and spacers (size 3, 5, 7, 8, 10, and 12 / one each) are included.

HSK40A - SCA 13 - 75		
Interfaz y diámetro de husillo	D1	Longitud de proyección
Shank size	D1	Projection length (L)

MTA

Morse Taper Holder

- Para el portaherramienta ahusado Morse con espiga
- For Morse taper shank with tang.

Tipo1
Type1

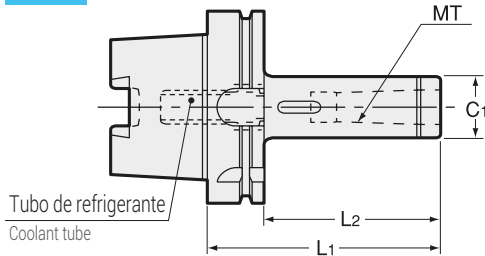

Tipo2
Type2

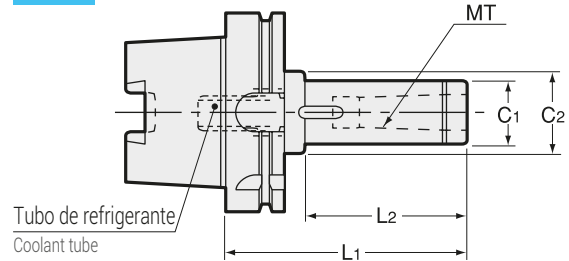

Tipo3
Type3

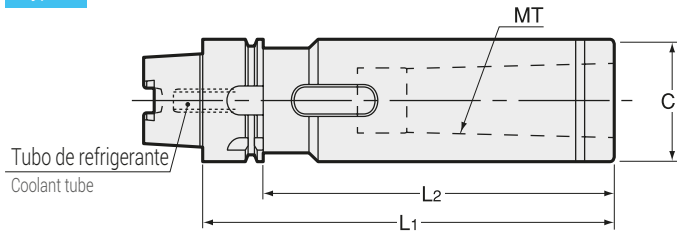

- Tubo de refrigerante incluido.
- Coolant tube is included.

Medidas Métricas - Metric Sizes

Unidad : Métrico
Unit : Metric

Código Code	Modelo Model	Tipo Type	MT	L1	C1	L2	C2	kg
5400 13001090	HSK40A -MTA1 -90	1	1	90	25	70	—	
5400 13002105	HSK40A -MTA2 -105	1	2	105	32	85	—	
5400 13003135	HSK40A -MTA3 -135	3	3	135	40	115	—	0.98
5400 14001095	HSK50A -MTA1 -95	1	1	95	25	69	—	
5400 14002110	HSK50A -MTA2 -110	1	2	110	32	84	—	
5400 14003135	HSK50A -MTA3 -135	1	3	135	40	109	—	
5400 75001105	HSK63A -MTA1 -105-H	1	1	105	25	79	—	
5400 75002120	HSK63A -MTA2 -120-H	1	2	120	32	94	—	
5400 75003150	HSK63A -MTA3 -150-H	1	3	150	40	124	—	
5400 75004165	HSK63A -MTA4 -165-H	1	4	165	50	139	—	
5400 77001105	HSK100A -MTA1 -105-H	2	1	105	25	66	32	2.3
5400 77002120	HSK100A -MTA2 -120-H	1	2	120	32	91	—	
5400 77003135	HSK100A -MTA3 -135-H	1	3	135	40	106	—	
5400 77004165	HSK100A -MTA4 -165-H	1	4	165	50	136	—	
5400 77005195	HSK100A -MTA5 -195-H	1	5	195	65	166	—	

Ejemplo para Ordenar - Ordering Example

HSK40A - MTA1 - 90

Interfaz y diámetro de husillo	MT	Longitud de proyección
Shank size	MT	Projection length (L)

Ejemplo para Ordenar - Ordering Example

HSK63A - MTA1 - 105 - H

Interfaz y diámetro de husillo	MT	Longitud de proyección	Barreno de Cambio Manual
Shank size	MT	Projection length	Manual clamp hole

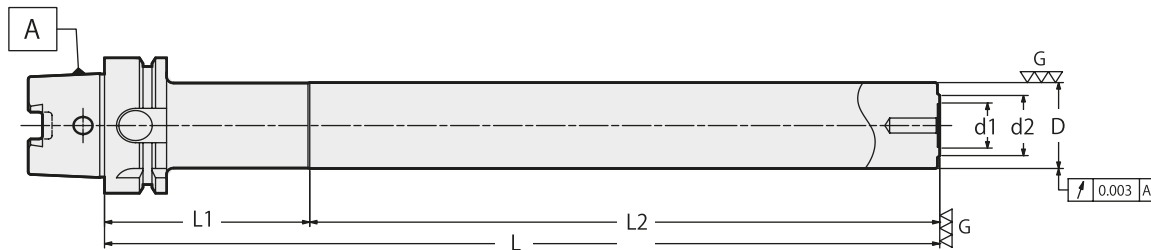

Medidas Métricas - Metric Sizes

Unidad : Métrico
Unit : Metric

Código Code	Modelo Model	L	L1	L2	D	d1	d2	kg
5560 12240180	HSK32A -MS24 -180	180	50	130	24	11	18	
5560 13240180	HSK40A -MS24 -180	180	50	130	24	11	18	
5560 14320250	HSK50A -MS32 -250	250	56	194	32	16	23	
5560 15400350	HSK63A -MS40 -350	350	86	264	40	21	28	3.8
5560 17400350	HSK100A -MS40 -350	350	89	261	40	21	28	5.1

Ejemplo para Ordenar - Ordering Example

HSK63A - MS40 - 350

Interfaz y diámetro de husillo	O.D. (D)	Longitud de proyección
Shank size	O.D. (D)	Projection length (L)

- BT
- CAT
- AHO
- HSK-A/E/F/C**
- HSK-T
- C
- UTS
- Máquinas Especializadas
Specialized Machine
- Equipo Relacionado
Related Equipment
- Taladro de Biselado & de Casquillo
Bush & Chamfering Drill
- Milling Chuck
- Collet Holder
- "R" Zero Holder
- Hydraulic Chuck
- Shrink Fit
- Tapping Chuck
- Arbors**
- Function Holder
- HSK-E
- HSK-F
- HSK-C
- Dimensions

NOTAS

KLD

Keyless Drill Chuck

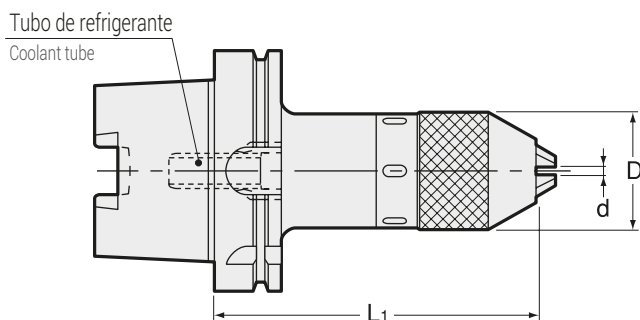

- Tubo de refrigerante incluido.
- Coolant tube is included.

Medidas Métricas - Metric Sizes

Unidad : Métrico
Unit : Metric

Código Code	Modelo Model	d	L1	D	kg	Llave Inglesa Spanner
5440 13060105	HSK40A -KLD6.5 -105	0.5 ~ 6.5	105	34	0.66	FC6.5LC
5440 14130135	HSK50A -KLD13 -135	0.5 ~ 13	135	50	1.7	FC13LC
5440 75130135	HSK63A -KLD13 -135-H	0.5 ~ 13	135	50	2.0	FC13LC
5440 77130135	HSK100A -KLD13 -135-H	0.5 ~ 13	135	50	3.4	FC13LC

Llave Inglesa (Opcional) Spanner (Optional)

Código Code	Modelo Model
2685 00000065	FC6.5LC
2685 00000130	FC13LC

Ejemplo para Ordenar - Ordering Example

HSK40A - KLD6.5 - 105

Interfaz y diámetro de husillo Shank size	Diá. Máximo de fresado Max. chucking dia.	Longitud de proyección Projection length (L)

Ejemplo para Ordenar - Ordering Example

HSK63A - KLD13 - 135 - H

Interfaz y diámetro de husillo Shank size	MT	Longitud de proyección Projection length	Barreno de Cambio Manual Manual clamp hole

- BT
- CAT
- AHO
- HSK-A/E/F/C
- HSK-T
- C
- UTS
- Máquinas Especializadas
Specialized Machine
- Equipo Relacionado
Related Equipment
- Taladro de Biselado & de Casquillo
Bush & Chamfering Drill
- Milling Chuck
- Collet Holder
- "R" Zero Holder
- Hydraulic Chuck
- Shrink Fit
- Tapping Chuck
- Arbors
- Function Holder
- HSK-E
- HSK-F
- HSK-C
- Dimensions

Angle Heads (ER Collet Type)

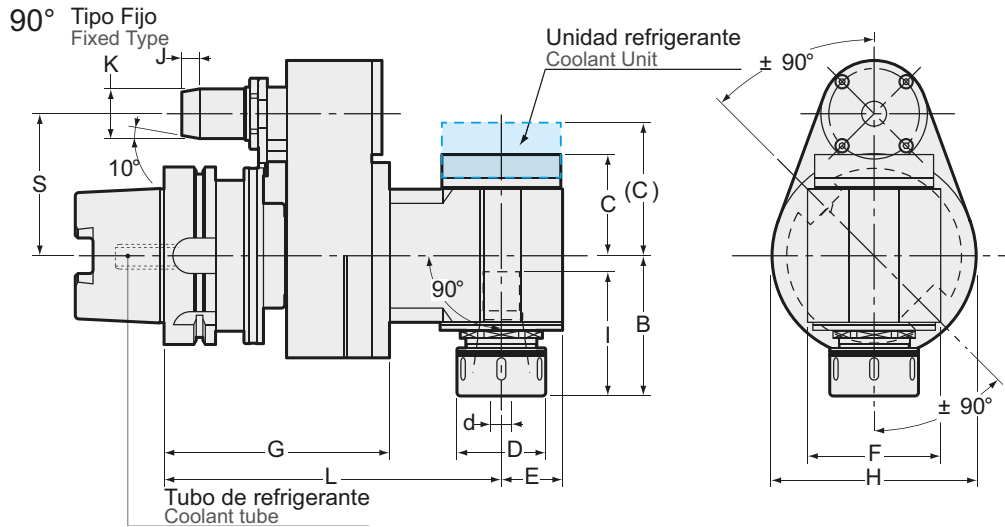

● Tubo de refrigerante incluido.

● Coolant tube is included.

※ Necesita de un bloque de posicionamiento. Favor de consultar de la pág.185-486.

※ Requires a positioning block. Please refer to P.185-186.

Unidad : Pulgadas
Unit : Inch

Código Code	Modelo Model	d	L	G	E	D	F	H	C (C)	B	I	J	K	S
5660 251176 ※※	HSK63A -AHE1190 -170 -65- ※※	0.020-0.276	6.693	4.843	0.669	0.906	2.008	3.543	1.299 (1.830)	1.693	1.575	0.315	0.772 (19.6mm)	2.559 (65mm)
5660 251106 ※※	-200 -65- ※※	0.020-0.276	7.874	4.843	0.669	0.906	2.008	3.543	1.299 (1.830)	1.693	1.575	0.315	0.772 (19.6mm)	2.559 (65mm)
5660 251136 ※※	-230 -65- ※※	0.020-0.276	9.055	4.843	0.669	0.906	2.008	3.543	1.299 (1.830)	1.693	1.575	0.315	0.772 (19.6mm)	2.559 (65mm)
5660 251166 ※※	-260 -65- ※※	0.020-0.276	10.236	5.512	0.669	0.906	2.008	3.543	1.299 (1.830)	1.693	1.575	0.315	0.772 (19.6mm)	2.559 (65mm)
5660 251196 ※※	-290 -65- ※※	0.020-0.276	11.417	5.512	0.669	0.906	2.008	3.543	1.299 (1.830)	1.693	1.575	0.315	0.772 (19.6mm)	2.559 (65mm)
5660 251676 ※※	HSK63A -AHE1690 -170 -65- ※※	0.020-0.394	6.693	4.843	0.866	1.260	2.283	3.543	1.752 (2.303)	2.441	2.559	0.315	0.772 (19.6mm)	2.559 (65mm)
5660 251606 ※※	-200 -65- ※※	0.020-0.394	7.874	4.843	0.866	1.260	2.283	3.543	1.752 (2.303)	2.441	2.559	0.315	0.772 (19.6mm)	2.559 (65mm)
5660 251636 ※※	-230 -65- ※※	0.020-0.394	9.055	4.843	0.866	1.260	2.283	3.543	1.752 (2.303)	2.441	2.559	0.315	0.772 (19.6mm)	2.559 (65mm)
5660 251666 ※※	-260 -65- ※※	0.020-0.394	10.236	5.512	0.866	1.260	2.283	3.543	1.752 (2.303)	2.441	2.559	0.315	0.772 (19.6mm)	2.559 (65mm)
5660 252076 ※※	HSK63A -AHE2090 -170 -65- ※※	0.020-0.512	6.693	4.843	1.102	1.378	2.638	3.543	2.008 (2.539)	2.717	2.717	0.315	0.772 (19.6mm)	2.559 (65mm)
5660 252006 ※※	-200 -65- ※※	0.020-0.512	7.874	4.843	1.102	1.378	2.638	3.543	2.008 (2.539)	2.717	2.717	0.315	0.772 (19.6mm)	2.559 (65mm)
5660 252036 ※※	-230 -65- ※※	0.020-0.512	9.055	4.843	1.102	1.378	2.638	3.543	2.008 (2.539)	2.717	2.717	0.315	0.772 (19.6mm)	2.559 (65mm)
5660 252576 ※※	HSK63A -AHE2590 -170 -65- ※※	0.020-0.630	6.693	4.843	1.102	1.654	2.638	3.543	2.008 (2.539)	2.717	2.717	0.315	0.772 (19.6mm)	2.559 (65mm)
5660 252506 ※※	-200 -65- ※※	0.020-0.630	7.874	4.843	1.102	1.654	2.638	3.543	2.008 (2.539)	2.717	2.717	0.315	0.772 (19.6mm)	2.559 (65mm)
5660 252536 ※※	-230 -65- ※※	0.020-0.630	9.055	4.843	1.102	1.654	2.638	3.543	2.008 (2.539)	2.717	2.717	0.315	0.772 (19.6mm)	2.559 (65mm)
5660 271178 ※※	HSK100A -AHE1190 -175 -80- ※※	0.020-0.276	6.890	5.039	0.669	0.906	2.008	3.543	1.299 (1.830)	1.693	1.575	0.394	1.102 (28mm)	3.150 (80mm)
5660 271108 ※※	-205 -80- ※※	0.020-0.276	8.071	5.039	0.669	0.906	2.008	3.543	1.299 (1.830)	1.693	1.575	0.394	1.102 (28mm)	3.150 (80mm)
5660 271138 ※※	-235 -80- ※※	0.020-0.276	9.252	5.039	0.669	0.906	2.008	3.543	1.299 (1.830)	1.693	1.575	0.394	1.102 (28mm)	3.150 (80mm)
5660 271168 ※※	-265 -80- ※※	0.020-0.276	10.433	5.709	0.669	0.906	2.008	3.543	1.299 (1.830)	1.693	1.575	0.394	1.102 (28mm)	3.150 (80mm)
5660 271198 ※※	-295 -80- ※※	0.020-0.276	11.614	5.709	0.669	0.906	2.008	3.543	1.299 (1.830)	1.693	1.575	0.394	1.102 (28mm)	3.150 (80mm)

Código Code	Modelo Model	d	L	G	E	D	F	H	C (C)	B	I	J	K	S
5660 271678 ※※	HSK100A -AHE1690 -175 -80- ※※	0.020-0.394	6.890	5.039	0.866	1.260	2.283	3.543	1.752 (2.303)	2.441	2.559	0.394	1.102 (28mm)	3.150 (80mm)
5660 271608 ※※	-205 -80- ※※	0.020-0.394	8.071	5.039	0.866	1.260	2.283	3.543	1.752 (2.303)	2.441	2.559	0.394	1.102 (28mm)	3.150 (80mm)
5660 271638 ※※	-235 -80- ※※	0.020-0.394	9.252	5.039	0.866	1.260	2.283	3.543	1.752 (2.303)	2.441	2.559	0.394	1.102 (28mm)	3.150 (80mm)
5660 271668 ※※	-265 -80- ※※	0.020-0.394	10.433	5.709	0.866	1.260	2.283	3.543	1.752 (2.303)	2.441	2.559	0.394	1.102 (28mm)	3.150 (80mm)
5660 272078 ※※	HSK100A -AHE2090 -175 -80- ※※	0.020-0.512	6.890	5.039	1.102	1.378	2.638	3.543	2.008 (2.539)	2.717	2.717	0.394	1.102 (28mm)	3.150 (80mm)
5660 272008 ※※	-205 -80- ※※	0.020-0.512	8.071	5.039	1.102	1.378	2.638	3.543	2.008 (2.539)	2.717	2.717	0.394	1.102 (28mm)	3.150 (80mm)
5660 272038 ※※	-235 -80- ※※	0.020-0.512	9.252	5.039	1.102	1.378	2.638	3.543	2.008 (2.539)	2.717	2.717	0.394	1.102 (28mm)	3.150 (80mm)
5660 272578 ※※	HSK100A -AHE2590 -175 -80- ※※	0.020-0.630	6.890	5.039	1.102	1.654	2.638	3.543	2.008 (2.539)	2.717	2.717	0.394	1.102 (28mm)	3.150 (80mm)
5660 272508 ※※	-205 -80- ※※	0.020-0.630	8.071	5.039	1.102	1.654	2.638	3.543	2.008 (2.539)	2.717	2.717	0.394	1.102 (28mm)	3.150 (80mm)
5660 272538 ※※	-235 -80- ※※	0.020-0.630	9.252	5.039	1.102	1.654	2.638	3.543	2.008 (2.539)	2.717	2.717	0.394	1.102 (28mm)	3.150 (80mm)
5660 273298 ※※	HSK100A -AHE3290 -190 -80- ※※	0.098-0.787	7.480	5.000	1.358	1.969	2.953	4.528	2.244 (2.776)	3.110	2.953	0.394	1.102 (28mm)	3.150 (80mm)
5660 273228 ※※	-220 -80- ※※	0.098-0.787	8.661	5.000	1.358	1.969	2.953	4.528	2.244 (2.776)	3.110	2.953	0.394	1.102 (28mm)	3.150 (80mm)
5660 273258 ※※	-250 -80- ※※	0.098-0.787	9.843	5.000	1.358	1.969	2.953	4.528	2.244 (2.776)	3.110	2.953	0.394	1.102 (28mm)	3.150 (80mm)
5660 274008 ※※	HSK100A -AHE4090 -205 -80- ※※	0.118-1.024	8.071	5.000	1.772	2.480	3.543	4.528	2.874 (3.406)	3.740	3.937	0.394	1.102 (28mm)	3.150 (80mm)
5660 274001 ※※	-205 -110- ※※	0.118-1.024	8.071	5.000	1.772	2.480	3.543	4.528	2.874 (3.406)	3.740	3.937	0.394	1.102 (28mm)	4.331 (110mm)

- ※ es para la dimensión A. Favor de consultar la pág. 185.
 - Al hacer su orden, favor de especificar la medida del émbolo (dimensión "A")
 - Los tipos de refrigeración a través del centro se producen según la solicitud.
 - El émbolo está fijo (no es ajustable).
 - La boquilla y la llave inglesa se venden por separado.
- ※ is for A dimension. Please refer to P. 185.
 - When ordering, please specify plunger size ("A" dimension).
 - Center-thru coolant types are produced upon request.
 - Plunger is fixed (non-adjustable)
 - Collet and spanner are sold separately.

Medida Size	Boquilla Collet	Tuerca ciega Nut	Llave Inglesa Spanner
AHE1190	ER11	HDP-07A	S-0
AHE1690	ER16	ERP-16	FK0030
AHE2090	ER20	ERP-20	FK0034
AHE2590	ER25	ERP-25	HS-1-16
AHE3290	ER32	ERP-32	HS-2-20
AHE4090	ER40	ERP-40	HS-2.5-25

Boquilla Collet
Pág. 094-095

Llave Inglesa Spanner
Pág. 099

Ejemplo para Ordenar - Ordering Example

HSK63A - AH 16 90 - 170 - 65 - **

Interfaz y diámetro de husillo Shank size	Máx. Diámetro Interno de boquilla Max. collet I.D.	Ángulo Angle	Longitud de proyección Projection length (L)	S	A Dimensión Dimension A
--	---	-----------------	---	---	----------------------------



AHSE, AHLE

0°-90°

Angle Heads (ER Collet Type)

(Tipo Flexible)
(Flexible Type)

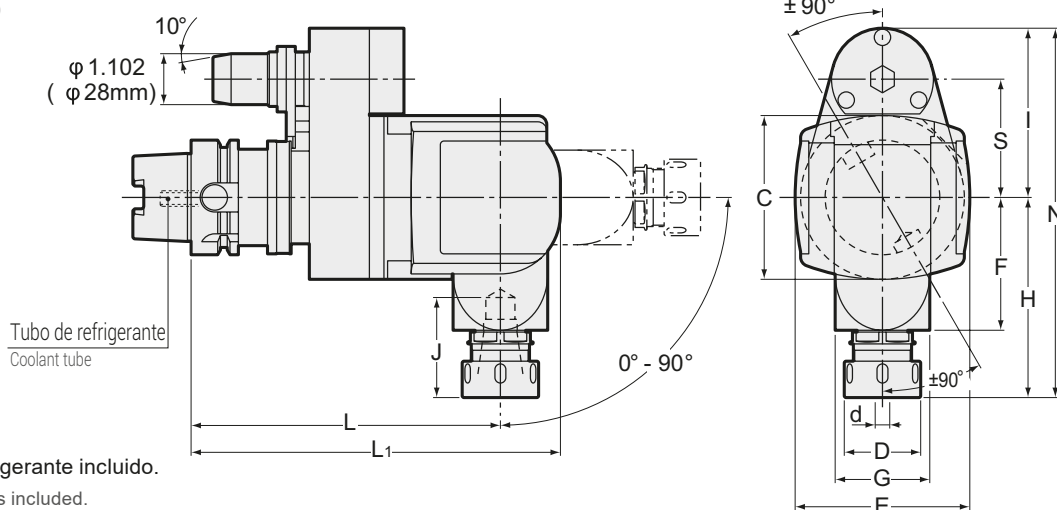

- Tubo de refrigerante incluido.
- Coolant tube is included.

※ Necesita de un bloque de posicionamiento. Favor de consultar la pág.185-186.
※ Requires a positioning block. Please refer to P.185-186.

Unidad : Pulgadas
Unit : Inch

Código Code	Modelo Model	d	L	L1	D	C	E	F	G	H	J	I	N	S
5634 051176**	HSK63A -AHSE11 -170 -65**	0.020-0.276	6.693	7.992	0.906	3.543	3.780	2.874	2.047	3.937	2.559	3.661	7.598	2.559 (65mm)
5634 051676**	HSK63A -AHSE16 -170 -65**	0.020-0.394	6.693	7.992	1.260	3.543	3.780	2.874	2.047	4.331	2.559	3.661	7.992	2.559 (65mm)
5634 052076**	HSK63A -AHSE20 -170 -65**	0.020-0.512	6.693	7.992	1.378	3.543	3.780	2.874	2.047	4.331	2.165	3.661	7.992	2.559 (65mm)
5634 052576**	HSK63A -AHSE25 -170 -65**	0.020-0.630	6.693	7.992	1.654	3.543	3.780	2.874	2.047	4.331	2.165	3.661	7.992	2.559 (65mm)
5634 071178**	HSK100A -AHSE11 -175 -80**	0.020-0.276	6.890	8.189	0.906	3.543	3.780	2.874	2.047	3.937	2.559	4.252	8.189	3.150 (80mm)
5634 071678**	HSK100A -AHSE16 -175 -80**	0.020-0.394	6.890	8.189	1.260	3.543	3.780	2.874	2.047	4.331	2.559	4.252	8.583	3.150 (80mm)
5634 072078**	HSK100A -AHSE20 -175 -80**	0.020-0.512	6.890	8.189	1.378	3.543	3.780	2.874	2.047	4.331	2.165	4.252	8.583	3.150 (80mm)
5634 072578**	HSK100A -AHSE25 -175 -80**	0.020-0.630	6.890	8.189	1.654	3.543	3.780	2.874	2.047	4.331	2.165	4.252	8.583	3.150 (80mm)
5634 071171**	HSK100A -AHSE11 -175 -110**	0.020-0.276	6.890	8.189	0.906	3.543	3.780	2.874	2.047	3.937	2.559	5.433	9.370	4.331 (110mm)
5634 071671**	HSK100A -AHSE16 -175 -110**	0.020-0.394	6.890	8.189	1.260	3.543	3.780	2.874	2.047	4.331	2.559	5.433	9.764	4.331 (110mm)
5634 072071**	HSK100A -AHSE20 -175 -110**	0.020-0.512	6.890	8.189	1.378	3.543	3.780	2.874	2.047	4.331	2.165	5.433	9.764	4.331 (110mm)
5634 072571**	HSK100A -AHSE25 -175 -110**	0.020-0.630	6.890	8.189	1.654	3.543	3.780	2.874	2.047	4.331	2.165	5.433	9.764	4.331 (110mm)
5634 172078**	HSK100A -AHLE20 -175 -80**	0.020-0.512	6.890	8.465	1.378	4.331	4.646	3.071	2.598	4.724	2.953	4.252	8.976	3.150 (80mm)
5634 172578**	HSK100A -AHLE25 -175 -80**	0.020-0.630	6.890	8.465	1.654	4.331	4.646	3.071	2.598	4.724	2.953	4.252	8.976	3.150 (80mm)
5634 173278**	HSK100A -AHLE32 -175 -80**	0.098-0.787	6.890	8.465	1.969	4.331	4.646	3.071	2.598	4.724	2.953	4.252	8.976	3.150 (80mm)
5634 172071**	HSK100A -AHLE20 -175 -110**	0.020-0.512	6.890	8.465	1.378	4.331	4.646	3.071	2.598	4.724	2.953	5.433	10.157	4.331 (110mm)
5634 172571**	HSK100A -AHLE25 -175 -110**	0.020-0.630	6.890	8.465	1.654	4.331	4.646	3.071	2.598	4.724	2.953	5.433	10.157	4.331 (110mm)
5634 173271**	HSK100A -AHLE32 -175 -110**	0.098-0.787	6.890	8.465	1.969	4.331	4.646	3.071	2.598	4.724	2.953	5.433	10.157	4.331 (110mm)

- ※ es para la dimensión A. Favor de consultar la pág. 185.
- Al hacer su orden, favor de especificar la medida del émbolo (dimensión "A")
- Los tipos de refrigeración a través del centro se producen según la solicitud.
- El émbolo está fijo (no es ajustable).
- La boquilla y la llave inglesa se venden por separado.
 - ※ is for A dimension. Please refer to P. 185.
 - When ordering, please specify plunger size ("A" dimension).
 - Center-thru coolant types are produced upon request.
 - Plunger is fixed (non-adjustable)
 - Collet and spanner are sold separately.

Medida Size	Boquilla Collet	Tuerca ciega Nut	Llave Inglesa Spanner
AHSE11	ER11	HDP-07A	S-0
AHSE16	ER16	ERP-16	FK0030
AHSE20	ER20	ERP-20	FK0034
AHSE25	ER25	ERP-25	HS-1-16
AHLE20	ER20	ERP-20	FK0034
AHLE25	ER25	ERP-25	HS-1-16
AHLE32	ER32	ERP-32	HS-2-20

Ejemplo para Ordenar - Ordering Example

HSK63A - AHE	16	90	- 170	- 65	- **
Interfaz y diámetro de husillo Shank size	Máx. Diámetro Interno de boquilla Max. collet I.D.	Ángulo Angle	Longitud de proyección Projection length (L)	S	A Dimensión Dimension A



HDC•A

High-Precision Collet Holder

- Adecuado para barrenado, rima y acabado en fresa
- Suitable for drilling, reaming and finish endmilling.

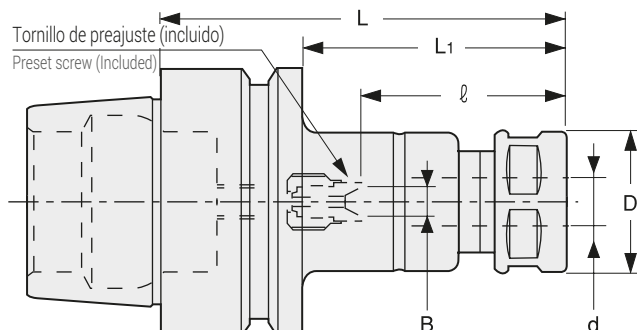

Unidad : Métrico
Unit : Metric

Código Code	Modelo Model	d	L	L1	B	ℓ	D	Tuerca ciega Nut	Tornillo de preajuste (incluida) Preset Screw	Boquilla Collet	Llave Inglesa Spanner
5360 51107040	HSK25E -HDC07A -40	0.5 ~ 7.0	40	30	—	29	23	HDP-07A	—	FDC-07	S-0
5360 51107060	-60	0.5 ~ 7.0	60	50	0 ~ 4	22 ~ 30	23	HDP-07A	HDS-07	FDC-07	S-0
5360 51109045	HSK25E -HDC09A -45	2.5 ~ 9.0	45	35	—	33	26	HDP-09	—	FDC-09	S-1L
5360 51109060	-60	2.5 ~ 9.0	60	50	0 ~ 4	27 ~ 36	26	HDP-09	HDS-09	FDC-09	S-1L
5360 52107045	HSK32E -HDC07A -45	0.5 ~ 7.0	45	25	—	31	23	HDP-07A	—	FDC-07	S-0
5360 52107060	-60	0.5 ~ 7.0	60	40	0 ~ 4	22 ~ 27	23	HDP-07A	HDS-07	FDC-07	S-0
5360 52109050	HSK32E -HDC09A -50	2.5 ~ 9.0	50	30	—	35	26	HDP-09	—	FDC-09	S-1L
5360 52109060	-60	2.5 ~ 9.0	60	40	0 ~ 4	27 ~ 33	26	HDP-09	HDS-09	FDC-09	S-1L
5360 52112060	HSK32E -HDC12A -60	2.5 ~ 12.0	60	40	—	44	32	HDP-12	—	FDC-12	S-3L
5360 52112075	-75	2.5 ~ 12.0	75	55	0 ~ 5	33 ~ 47	32	HDP-12	HDS-12	FDC-12	S-3L
5360 53107045	HSK40E -HDC07A -45	0.5 ~ 7.0	45	25	—	31	23	HDP-07A	—	FDC-07	S-0
5360 53107060	-60	0.5 ~ 7.0	60	40	0 ~ 4	22 ~ 27	23	HDP-07A	HDS-07	FDC-07	S-0
5360 53107075	-75	0.5 ~ 7.0	75	55	0 ~ 4	22 ~ 42	23	HDP-07A	HDS-07	FDC-07	S-0
5360 53107090	-90	0.5 ~ 7.0	90	70	0 ~ 4	22 ~ 45	23	HDP-07A	HDS-07	FDC-07	S-0
5360 53107120	-120	0.5 ~ 7.0	120	100	0 ~ 4	22 ~ 45	23	HDP-07A	HDS-07	FDC-07	S-0
5360 53109045	HSK40E -HDC09A -45	2.5 ~ 9.0	45	25	—	30	26	HDP-09	—	FDC-09	S-1L
5360 53109060	-60	2.5 ~ 9.0	60	40	0 ~ 4	27 ~ 32	26	HDP-09	HDS-09	FDC-09	S-1L
5360 53109075	-75	2.5 ~ 9.0	75	55	0 ~ 4	27 ~ 42	26	HDP-09	HDS-09	FDC-09	S-1L
5360 53109090	-90	2.5 ~ 9.0	90	70	0 ~ 4	27 ~ 57	26	HDP-09	HDS-09	FDC-09	S-1L
5360 53109120	-120	2.5 ~ 9.0	120	100	0 ~ 4	27 ~ 57	26	HDP-09	HDS-09	FDC-09	S-1L
5360 53112060	HSK40E -HDC12A -60	2.5 ~ 12.0	60	40	—	44	32	HDP-12	—	FDC-12	S-3L
5360 53112075	-75	2.5 ~ 12.0	75	55	0 ~ 5	33 ~ 46	32	HDP-12	HDS-12	FDC-12	S-3L
5360 53112090	-90	2.5 ~ 12.0	90	70	0 ~ 5	33 ~ 49	32	HDP-12	HDS-12	FDC-12	S-3L
5360 53112120	-120	2.5 ~ 12.0	120	100	0 ~ 5	33 ~ 69	32	HDP-12	HDS-12	FDC-12	S-3L
5360 53112150	-150	2.5 ~ 12.0	150	130	0 ~ 5	33 ~ 69	32	HDP-12	HDS-12	FDC-12	S-3L
5360 53116060	HSK40E -HDC16A -60	3.5 ~ 16.0	60	40	—	43	36	HDP-16	—	FDC-16	S-4L
5360 53116075	-75	3.5 ~ 16.0	75	55	0 ~ 6	38 ~ 46	36	HDP-16	HDS-16	FDC-16	S-4L
5360 53116090	-90	3.5 ~ 16.0	90	70	0 ~ 6	38 ~ 48	36	HDP-16	HDS-16	FDC-16	S-4L
5360 53116120	-120	3.5 ~ 16.0	120	100	0 ~ 6	38 ~ 78	36	HDP-16	HDS-16	FDC-16	S-4L
5360 53116150	-150	3.5 ~ 16.0	150	130	0 ~ 6	38 ~ 82	36	HDP-16	HDS-16	FDC-16	S-4L
5360 54107045	HSK50E -HDC07A -45	0.5 ~ 7.0	45	19	—	28	23	HDP-07A	—	FDC-07	S-0
5360 54107060	-60	0.5 ~ 7.0	60	34	0 ~ 4	22 ~ 28	23	HDP-07A	HDS-07	FDC-07	S-0
5360 54107075	-75	0.5 ~ 7.0	75	49	0 ~ 4	22 ~ 39	23	HDP-07A	HDS-07	FDC-07	S-0
5360 54107090	-90	0.5 ~ 7.0	90	64	0 ~ 4	22 ~ 45	23	HDP-07A	HDS-07	FDC-07	S-0
5360 54107120	-120	0.5 ~ 7.0	120	94	0 ~ 4	22 ~ 45	23	HDP-07A	HDS-07	FDC-07	S-0
5360 54109060	HSK50E -HDC09A -60	2.5 ~ 9.0	60	34	—	42	26	HDP-09	—	FDC-09	S-1L
5360 54109075	-75	2.5 ~ 9.0	75	49	0 ~ 4	27 ~ 38	26	HDP-09	HDS-09	FDC-09	S-1L
5360 54109090	-90	2.5 ~ 9.0	90	64	0 ~ 4	27 ~ 53	26	HDP-09	HDS-09	FDC-09	S-1L
5360 54109120	-120	2.5 ~ 9.0	120	94	0 ~ 4	27 ~ 57	26	HDP-09	HDS-09	FDC-09	S-1L

Código Code	Modelo Model	d	L	L1	B	ℓ	D	Tuerca ciega Nut	Tornillo de preajuste (incluida) Preset Screw	Boquilla Collet	Llave Inglesa Spanner
5360 54112060	HSK50E -HDC12A -60	2.5 ~ 12.0	60	34	—	41	32	HDP-12	—	FDC-12	S-3L
5360 54112075	-75	2.5 ~ 12.0	75	49	0 ~ 5	33 ~ 43	32	HDP-12	HDS-12		
5360 54112090	-90	2.5 ~ 12.0	90	64	0 ~ 5	33 ~ 46	32	HDP-12	HDS-12		
5360 54112120	-120	2.5 ~ 12.0	120	94	0 ~ 5	33 ~ 69	32	HDP-12	HDS-12		
5360 54112150	-150	2.5 ~ 12.0	150	124	0 ~ 5	33 ~ 69	32	HDP-12	HDS-12		
5360 54116060	HSK50E -HDC16A -60	3.5 ~ 16.0	60	34	—	40	36	HDP-16	—	FDC-16	S-4L
5360 54116075	-75	3.5 ~ 16.0	75	49	—	54	36	HDP-16	HDS-16		
5360 54116090	-90	3.5 ~ 16.0	90	64	0 ~ 6	38 ~ 48	36	HDP-16	HDS-16		
5360 54116120	-120	3.5 ~ 16.0	120	94	0 ~ 6	38 ~ 78	36	HDP-16	HDS-16		
5360 54116150	-150	3.5 ~ 16.0	150	124	0 ~ 6	38 ~ 82	36	HDP-16	HDS-16		
5360 54122075	HSK50E -HDC22A -75	3.5 ~ 22.0	75	49	—	53	46	HDP-22	—	FDC-22	S-5L
5360 54122090	-90	3.5 ~ 22.0	90	64	0 ~ 8	47 ~ 56	46	HDP-22	HDS-22		
5360 54122120	-120	3.5 ~ 22.0	120	94	0 ~ 8	47 ~ 73	46	HDP-22	HDS-22		
5360 54122150	-150	3.5 ~ 22.0	150	124	0 ~ 8	47 ~ 103	46	HDP-22	HDS-22		

- La boquilla, la llave inglesa y el tornillo Allen opresor de preajuste se venden por separado. El tornillo estándar de preajuste está incluido.
- ℓ indica la dimensión al usarlo con un tornillo de preajuste.
- Consulte la pág. 485 para conocer el Torque recomendado en nuestros productos.
 - Collet, spanner and hexagon head preset screw are sold separately. Standard preset screw is included.
 - ℓ indicates dimension when using with a preset screw.
 - See P.485 for standard Tightening Torque.

Boquilla Collet Pág. 090-093 	Llave de Torque Spanner Pág. 099 	Tornillo de preajuste Preset screw Pág. 098 
--	--	---

Ejemplo para Ordenar - Ordering Example

HSK50E	- HDC	12	A	- 60
Interfaz y diámetro de husillo Shank size		Máx. Diámetro Interno de boquilla Max. collet I.D.		Longitud de proyección Projection length (L)

Collet Holder For Small Diameters

- Para barrenado en espacios angostos.
- For drilling in tight space.

Tornillo de preajuste

Portaherramienta ERC8: se vende por separado
Portaherramienta con diferente diámetro a 8: incluido

Preset Screw
ERC8 Holder : Sold separately
Other Holder : Included

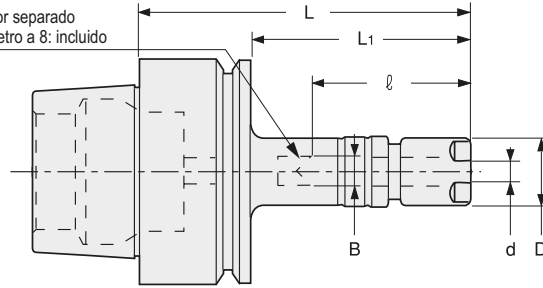

Unidad : Métrico
Unit : Metric

Código Code	Modelo Model	d	L	L1	B	ℓ	D	Tuerca ciega Nut	Tornillo de preajuste Preset Screw	Boquilla Collet	Llave Inglesa Spanner
5370 50108035	HSK25E -ERC8 -35	0.5 ~ 5.0	35	25	—	24	12	ERP-8	—		
5370 50108045	-45	0.5 ~ 5.0	45	35	—	34	12	ERP-8	—	ER8	S-8E
5370 50108060	-60	0.5 ~ 5.0	60	50	— (0 ~ 2.4)	34 (19 ~ 23)	12	ERP-8	(ES8)		
5370 50110045	HSK25E -ERC11S -45	0.5 ~ 7.0	45	35	—	34	16	ERP-11S	—	ER11	S-11E
5370 50110060	-60	0.5 ~ 7.0	60	50	0 ~ 4	22 ~ 30	16	ERP-11S	HDS-07A-ES11		
5370 50208045	HSK32E -ERC8 -45	0.5 ~ 5.0	45	25	—	31	12	ERP-8	—	ER8	S-8E
5370 50208060	-60	0.5 ~ 5.0	60	40	—	34	12	ERP-8	—	ER8	S-8E
5370 50210045	HSK32E -ERC11S -45	0.5 ~ 7.0	45	25	—	31	16	ERP-11S	—	ER11	S-11E
5370 50210060	-60	0.5 ~ 7.0	60	40	0 ~ 4	22 ~ 27	16	ERP-11S	HDS-07A-ES11		
5370 50308040	HSK40E -ERC8 -40	0.5 ~ 5.0	40	20	—	26	12	ERP-8	—	ER8	S-8E
5370 50308060	-60	0.5 ~ 5.0	60	40	— (0 ~ 2.4)	34 (19 ~ 22)	12	ERP-8	(ES8)	ER8	S-8E
5370 50310045	HSK40E -ERC11S -45	0.5 ~ 7.0	45	25	—	31	16	ERP-11S	—	ER11	S-11E
5370 50310060	-60	0.5 ~ 7.0	60	40	0 ~ 4	22 ~ 24	16	ERP-11S	HDS-07A-ES11		
5370 50408045	HSK50E -ERC8 -45	0.5 ~ 5.0	45	19	—	35	12	ERP-8	—		
5370 50408060	-60	0.5 ~ 5.0	60	34	—	50	12	ERP-8	—	ER8	S-8E
5370 50408075	-75	0.5 ~ 5.0	75	49	— (0 ~ 2.4)	34 (19 ~ 26)	12	ERP-8	(ES8)		
5370 50410045	HSK50E -ERC11S -45	0.5 ~ 7.0	45	19	—	28	16	ERP-11S	—		
5370 50410060	-60	0.5 ~ 7.0	60	34	0 ~ 4	22 ~ 28	16	ERP-11S	HDS-07A-ES11	FDC-07	S-11E
5370 50410075	-75	0.5 ~ 7.0	75	49	0 ~ 4	22 ~ 39	16	ERP-11S	HDS-07A-ES11		

1. La boquilla y la llave inglesa se venden por separado.
2. El ES8, un tornillo de pre-ajuste para el ERC8, se vende por separado.
3. Las dimensiones "B" e "ℓ" entre corchetes sirven para usar el tornillo de preajuste ES8.
4. Consulte la pág. 096 para conocer la longitud mínima para insertar herramientas en caso de usar nuestras boquillas refrigerantes.
5. Consulte la pág. 521 para conocer el Torque estándar de apriete.

1. Collet and spanner are sold separately.
2. ES8, a preset screw for ERC8, is sold separately.
3. "B" and "ℓ" dimensions in brackets are for using ES8 preset screw.
4. Refer to P. 096 for minimum tool insertion length in case of using our coolant collets.
5. See P. 521 for standard Tightening Torque.

Boquilla Collet Pág. 094-095 	Llave Inglesa Spanner Pág. 099 	Tornillo de preajuste Preset screw Pág. 098 
---	---	--

Ejemplo para Ordenar - Ordering Example

HSK40E - ERC 8 - 40

Interfaz y diámetro de husillo Shank size	Máx. Diámetro Interno de boquilla Max. collet I.D.	Longitud de proyección Projection length (L)
--	---	---

PHC-A

Power Hydro Chuck

- Hydro Chuck con capacidad de uso de boquillas. Adecuado para cortes de alta precisión.
- Hydro chuck with collet holder flexibility. Suitable for high precision cutting.

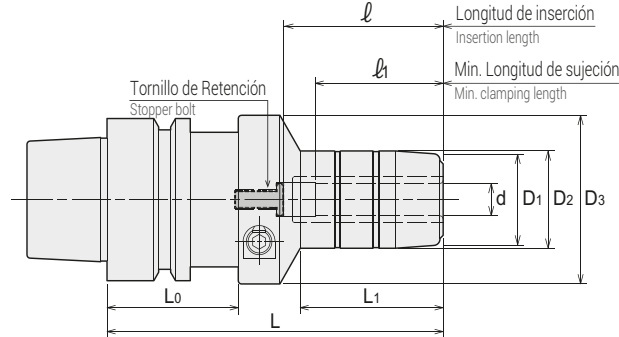

Medidas Métricas - Metric Sizes

Unidad : Métrico
Unit : Metric

Código Code	Modelo Model	d	L	L1	D1	D2	D3	L0	ℓ	ℓ1	Kg	Llave Allen (Opcional) Hex. Wrench (Optional)
5730 53206090	HSK40E -PHC06A-90	6	90	30	24	26	46	35	34	29	0.7	L-4T (4mm)
5730 53207090	HSK40E -PHC07A-90	7	90	30	26	28	46	35	34	29		
5730 53208090	HSK40E -PHC08A-90	8	90	30	26	28	46	35	34	29		
5730 53209105	HSK40E -PHC09A-105	9	105	44	28	30	52	35	50	40		
5730 53210105	HSK40E -PHC10A-105	10	105	44	28	30	52	35	50	40		
5730 53211105	HSK40E -PHC11A-105	11	105	45	30	32	52	35	50	40		
5730 53212105	HSK40E -PHC12A-105	12	105	45	30	32	52	35	50	40		L-4T (4mm)
5730 54206090	HSK50E -PHC06A-90	6	90	30	24	26	46	41	34	29	0.9	
5730 54207090	HSK50E -PHC07A-90	7	90	30	26	28	46	41	34	29		
5730 54208090	HSK50E -PHC08A-90	8	90	30	26	28	46	41	34	29		
5730 54209105	HSK50E -PHC09A-105	9	105	44	28	30	52	41	50	40		
5730 54210105	HSK50E -PHC10A-105	10	105	44	28	30	52	41	50	40		
5730 54211105	HSK50E -PHC11A-105	11	105	45	30	32	52	41	50	40		
5730 54212105	HSK50E -PHC12A-105	12	105	45	30	32	52	41	50	40		
5730 54213105	HSK50E -PHC13A-105	13	105	46	34	36	52	41	50	40		
5730 54214105	HSK50E -PHC14A-105	14	105	46	34	36	52	41	50	40		
5730 54215105	HSK50E -PHC15A-105	15	105	46	36	38	52	41	50	40		
5730 54216105	HSK50E -PHC16A-105	16	105	46	36	38	52	41	50	40		
5730 54220105	HSK50E -PHC20A-105	20	105	49	40	42	46	41	50	40		

1. Favor de utilizar herramientas de corte con una tolerancia menor a h7. Es recomendada una tolerancia menor que 0/-0.01 para nuevas herramientas de corte.
 2. No dejar el portaherramienta con el tornillo de accionamiento apretado cuando el diámetro interno del portaherramienta se encuentre sin herramienta de corte.
 3. PHC0500A Y PHC0750A cuentan con orificios de acople para perno, para las boquillas que tienen incluido el perno de retención.
1. Please use a cutting tool with a tolerance of less than h7. A tolerance of less than 0/-0.01 is recommended for new cutting tools.
 2. Do not leave the holder with actuating screw tightened when the chuck is empty.
 3. PHC12A and PHC20A have pin holes for collet with stopper pin on its body.

Torque de ajuste (Llave Allen : Pág. 520)
Tightening torque (Torque wrench : P.520)

Model Model	I.D. (d) mm	Torque de ajuste Tightening torque (Nm)
PHC-A	06 ~ 08	11 ~ 12
PHC-A	09 ~ 20	7 ~ 8
PHC-A	25, 32	29 ~ 30

Boquilla PHS
PHS Collet
Pág.114

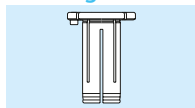

Llave Allen
Hex. wrench
Pág. 099



Ejemplo para Ordenar - Ordering Example

HSK50E - PHC 12 A - 105

Interfaz y diámetro de husillo
Shank size

Diámetro Interno
I.D. (d)

Longitud de proyección
Projection length (L)

SRD

Shrink Fit (DIN Standard)

- El método de contracción sujeta firmemente a una herramienta de corte al calentar y enfriar el portaherramienta. Alta precisión y mucha fuerza de fresado. (Para DIN)
- Shrinkage method clamps a cutting tool firmly by heating and cooling the chuck. High precision and strong chucking force. (DIN Type)

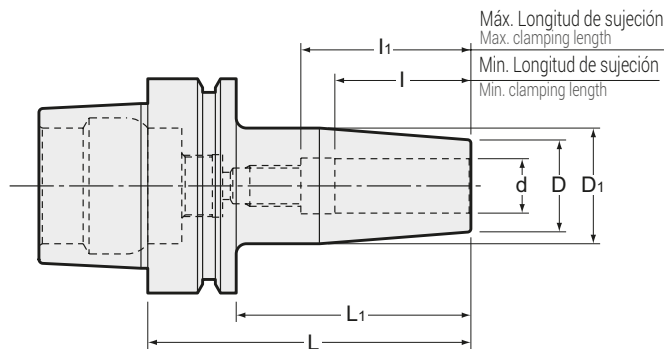

Medida en Pulgadas - Inch Sizes

Unidad : Pulgadas
Unit : Inch

Código Code	Modelo Model	d	L	L1	D	D1	I	I1
5644 43308080	HSK40E -SRD0250 A -80	0.250	3.150	2.362	0.827	1.063	1.024	1.417
5644 43308120	-120	0.250	4.724	3.937	0.827	1.063	1.024	1.417
5644 43308160	-160	0.250	6.299	5.512	0.827	1.063	1.024	1.417
5644 43310080	HSK40E -SRD0312 A -80	0.312	3.150	2.362	0.827	1.063	1.024	1.417
5644 43310120	-120	0.312	4.724	3.937	0.827	1.063	1.024	1.969
5644 43310160	-160	0.312	6.299	5.512	0.827	1.063	1.024	1.969
5644 43312080	HSK40E -SRD0375 A -80	0.375	3.150	2.362	0.945	1.260	1.260	1.654
5644 43312120	-120	0.375	4.724	3.937	0.945	1.260	1.260	1.969
5644 43312160	-160	0.375	6.299	5.512	0.945	1.260	1.260	1.969
5644 43316090	HSK40E -SRD0500 A -90	0.500	3.543	2.756	0.945	1.260	1.457	1.850
5644 43316120	-120	0.500	4.724	3.937	0.945	1.260	1.457	2.756
5644 43316160	-160	0.500	6.299	5.512	0.945	1.260	1.457	2.756
5644 43320090	HSK40E -SRD0625 A -90	0.625	3.543	2.756	1.063	1.339	1.575	1.969
5644 43320120	-120	0.625	4.724	3.937	1.063	1.339	1.575	2.756
5644 43320160	-160	0.625	6.299	5.512	1.063	1.339	1.575	2.756

Siempre use herramientas de zanco de carburo con un rango de tolerancia h6.
Always use carbide shank tools with h6 tolerance.

Tabla de dispositivos térmicos Heating device chart

Dispositivo térmico Heating device	Portaherramienta - chuck	
	SRD0250A, SRD0312A	SRD0375A~SRD1500A
ISG3400	Sí / Yes	Sí / Yes
SRK-HA1, HB2	No	Sí / Yes

Ejemplo para Ordenar - Ordering Example

HSK40A - SRD 0250 A - 120

Interfaz y diámetro de husillo Shank size	Diámetro Interno I.D. (d)	Longitud de proyección Projection length (L)
--	------------------------------	---

BT
CAT
AHO
HSK-A/E/F/C
HSK-T
C
UTS
Máquinas Especializadas
Specialized Machine
Equipo Relacionado
Related Equipment
Taladro de Biselado & de Casquillo
Bush & Chamfering Drill

Milling Chuck

Collet Holder

"R" Zero Holder

Hydraulic Chuck

Shrink Fit

Tapping Chuck

Arbors

Function Holder

HSK-E

HSK-F

HSK-C

Dimensions

Shrink Fit (Slim Type)

- El método de contracción sujeta firmemente a una herramienta de corte al calentar y enfriar el portaherramienta. Alta precisión y mucha fuerza de sujeción. (Tipo delgado)
- Shrinkage method clamps a cutting tool firmly by heating and cooling the chuck. High precision and strong Clamping force. (Slim Type)

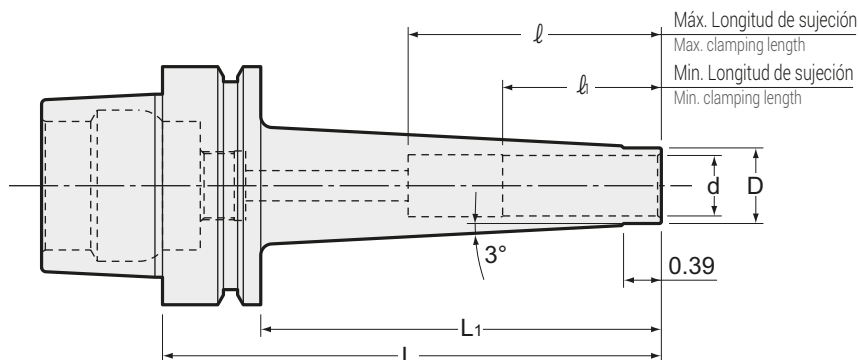

Medida en Pulgadas - Inch Sizes

Unidad : Pulgadas
Unit : Inch

Código Code	Modelo Model	d	L	L1	D	ℓ1	ℓ
5644 33308090	HSK40E -SRS0250A -90	0.250	3.543	2.756	0.354	1.024	1.417
5644 33308120	-120	0.250	4.724	3.937	0.354	1.024	1.417
5644 33310090	HSK40E -SRS0312A -90	0.312	3.543	2.756	0.433	1.024	1.969
5644 33310120	-120	0.312	4.724	3.937	0.433	1.024	1.969
5644 33312090	HSK40E -SRS0375A -90	0.375	3.543	2.756	0.512	1.260	1.969
5644 33312120	-120	0.375	4.724	3.937	0.512	1.260	1.969
5644 33316090	HSK40E -SRS0500A -90	0.500	3.543	2.756	0.591	1.457	2.756
5644 33316120	-120	0.500	4.724	3.937	0.591	1.457	2.756
5644 33320090	HSK40E -SRS0625A -90	0.625	3.543	2.756	0.787	1.575	2.756
5644 33320120	-120	0.625	4.724	3.937	0.787	1.575	3.150

Siempre use herramientas de zanco de carburo con tolerancia dentro de h6.
Always use carbide shank tools with h6 tolerance.

Tabla de dispositivos térmicos Heating device chart

Dispositivo térmico Heating device	Portaherramienta - chuck	
	SRS0250A, SRS0312A SRS6A, SRS8A	SRS0375A~SRS0750A SRS10A~SRS20A
ISG3400	Sí / Yes	Sí / Yes
SRK-HA1, HB2	No	Sí / Yes

Ejemplo para Ordenar - Ordering Example

HSK40E - SRS 0250 A - 120

Interfaz y diámetro de husillo
Shank size

Diámetro Interno
I.D. (d)

Longitud de proyección
Projection length (L)

HDC•A

High-Precision Collet Holder

- Adecuado para barrenado, rima y acabado en fresa.
- Suitable for drilling, reaming and finish endmilling.

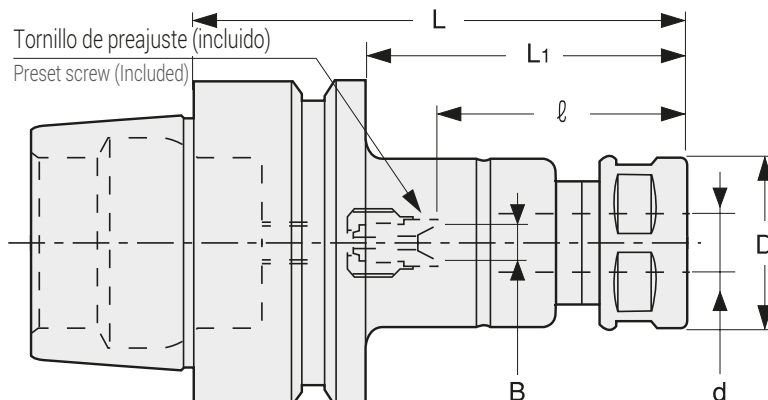

Unidad : Métrico
Unit : Metric

Código Code	Modelo Model	d	L	L1	B	ℓ	D	Tuerca ciega Nut	Tornillo de preajuste Preset Screw	Boquilla Collet	Llave Inglesa Spanner
5360 65107075	HSK63F -HDC07A-75	0.5 ~ 7.0	75	49	0 ~ 4	22 ~ 30	23	HDP-07A	HDS-07	FDC-07	S-0
5360 65107090	-90	0.5 ~ 7.0	90	64	0 ~ 4	22 ~ 45	23	HDP-07A	HDS-07		
5360 65107105	-105	0.5 ~ 7.0	105	79	0 ~ 4	22 ~ 45	23	HDP-07A	HDS-07		
5360 65107135	-135	0.5 ~ 7.0	135	109	0 ~ 4	22 ~ 45	23	HDP-07A	HDS-07		
5360 65109075	HSK63F -HDC09A-75	2.5 ~ 9.0	75	49	0 ~ 4	27 ~ 36	26	HDP-09	HDS-09	FDC-09	S-1L
5360 65109090	-90	2.5 ~ 9.0	90	64	0 ~ 4	27 ~ 45	26	HDP-09	HDS-09		
5360 65109105	-105	2.5 ~ 9.0	105	79	0 ~ 4	27 ~ 57	26	HDP-09	HDS-09		
5360 65109135	-135	2.5 ~ 9.0	135	109	0 ~ 4	27 ~ 57	26	HDP-09	HDS-09		
5360 65109165	-165	2.5 ~ 9.0	165	139	0 ~ 4	27 ~ 57	26	HDP-09	HDS-09		
5360 65112075	HSK63F -HDC12A-75	2.5 ~ 12.0	75	49	—	48	32	HDP-12	—	FDC-12	S-3L
5360 65112090	-90	2.5 ~ 12.0	90	64	0 ~ 5	33 ~ 40	32	HDP-12	HDS-12		
5360 65112105	-105	2.5 ~ 12.0	105	79	0 ~ 5	33 ~ 55	32	HDP-12	HDS-12		
5360 65112135	-135	2.5 ~ 12.0	135	109	0 ~ 5	33 ~ 69	32	HDP-12	HDS-12		
5360 65112165	-165	2.5 ~ 12.0	165	139	0 ~ 5	33 ~ 69	32	HDP-12	HDS-12		
5360 65116075	HSK63F -HDC16A-75	3.5 ~ 16.0	75	49	—	47	36	HDP-16	—	FDC-16	S-4L
5360 65116090	-90	3.5 ~ 16.0	90	64	0 ~ 6	38 ~ 49	36	HDP-16	HDS-16		
5360 65116105	-105	3.5 ~ 16.0	105	79	0 ~ 6	38 ~ 52	36	HDP-16	HDS-16		
5360 65122075	HSK63F -HDC22A-75	3.5 ~ 22.0	75	49	—	50	46	HDP-22	—		
5360 65122090	-90	3.5 ~ 22.0	90	64	—	60	46	HDP-22	HDS-22	FDC-22	S-5L
5360 65122105	-105	3.5 ~ 22.0	105	79	0 ~ 8	47 ~ 62	46	HDP-22	HDS-22		

1. La boquilla, llave inglesa, tornillo Allen opresor de preajuste y el tornillo de preajuste se venden por separado. Incluye el tornillo de preajuste estándar.
3. L1 indica la dimensión al usarlo con un tornillo de preajuste.
4. Consulte la pág. 520 para conocer el Torque estándar de apriete.

1. Collet, spanner and hexagon head preset screw are sold separately. Standard preset screw is included.
2. ℓ indicates dimension when using with a preset screw.
3. See P.520 for standard Tightening Torque.

Boquilla Collet Pág. 090-093 	Llave Inglesa Spanner Pág. 099 	Tornillo de preajuste Preset screw Pág. 098 
---	---	--

Ejemplo para Ordenar - Ordering Example

HSK63F - HDC 12 A - 105

Interfaz y diámetro de husillo
Shank size

Máx. Diámetro Interno de boquilla
Max. collet I.D.

Longitud de proyección
Projection length (L)

Collet Holder For Small Diameters

- Para barrenado en espacios reducidos.
- For drilling in tight space.

Tornillo de preajuste

Portaherramienta ERC8: se vende por separado
Portaherramientas con diferente diámetro a 8: incluido

Preset Screw

ERC8 Holder : Sold separately
Other Holder : Included

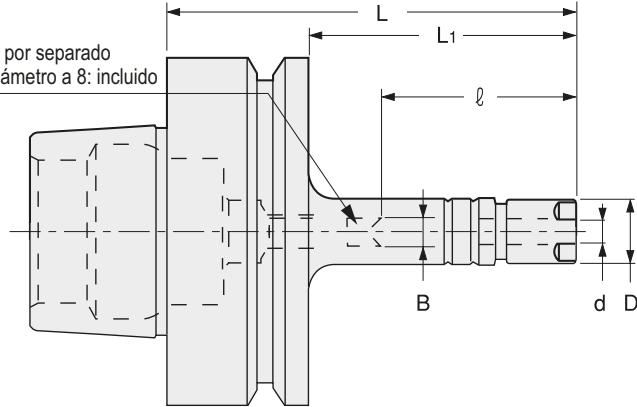

Unidad : Métrico
Unit : Metric

Código Code	Modelo Model	d	L	L1	B	l	D	Tuerca ciega Nut	kg	Tornillo de preajuste Preset Screw	Boquilla Collet	Llave Inglesa Spanner
5370 60508075	HSK63F -ERC8 -75	0.5 ~ 5.0	75	49	— (0 ~ 2.4)	³⁴ (19 ~ 31)	12	ERP-8	0.7	ES8 (Opcional / Optional)	ER8	S-8E
5370 60508090	-90	0.5 ~ 5.0	90	64	— (0 ~ 2.4)	³⁴ (19 ~ 31)	12	ERP-8				
5370 60508105	-105	0.5 ~ 5.0	105	79	— (0 ~ 2.4)	³⁴ (19 ~ 31)	12	ERP-8	0.7			
5370 60510075	HSK63F -ERC11S -75	0.5 ~ 7.0	75	49	0 ~ 4	22 ~ 30	16	ERP-11S	0.8	HDS-07A- ES11 (Include / Included)	FDC-07	S-11E
5370 60510090	-90	0.5 ~ 7.0	90	64	0 ~ 4	22 ~ 45	16	ERP-11S	0.8			
5370 60510105	-105	0.5 ~ 7.0	105	79	0 ~ 4	22 ~ 45	16	ERP-11S	0.8			

1. La boquilla y la llave inglesa se venden por separado.
2. El ES8, un tornillo de preajuste para el ERC8, se vende por separado. El ERC11S incluye un tornillo estándar de preajuste HDS-07A-ES11.
3. Las dimensiones "B" e "l" entre parentesis sirven para usar el tornillo de preajuste ES8.
5. Consulte la pág. 520 para conocer el torque estándar de apriete.

1. Collet and spanner are sold separately.
2. ES8, a preset screw for ERC8, is sold separately. ERC11S includes a standard preset screw HDS-07A-ES11.
3. "B" and "l" dimensions in brackets are for using ES8 preset screw.
4. See P.520 for standard Tightening Torque.

Boquilla Collet Pág. 094-095 	Llave Inglesa Spanner Pág. 099 	Tornillo de preajuste Preset screw Pág. 098 
---	---	--

Ejemplo para Ordenar - Ordering Example

HSK63F	- ERC	8	-	75
Interfaz y diámetro de husillo Shank size		Máx. Diámetro Interno de boquilla Max. collet I.D.		Longitud de proyección Projection length (L)

PHC-A

Power Hydro Chuck

- Hydro Chuck con capacidad de uso de boquillas. Adecuado para cortes de alta precisión.
- Hydro Chuck with collet holder flexibility. Suitable for high precision cutting.

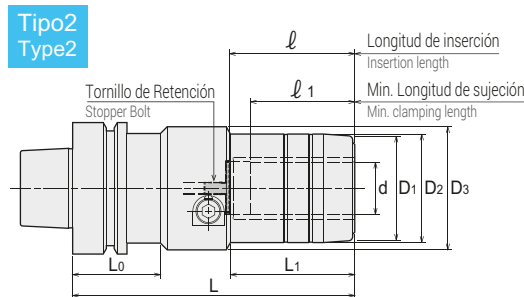
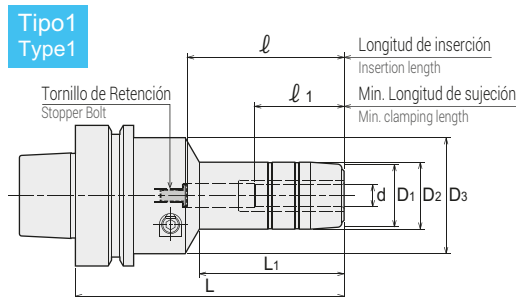

Medidas Métricas - Metric Sizes

Unidad : Métrico
Unit : Metric

Código Code	Modelo Model	Tipo Type	d	L	L1	D1	D2	D3	L0	ℓ	ℓ1	Kg	Llave Allen (Opcional) Hex.Wrench(Optional)
5730 65206075	HSK63F -PHC06A-75	1	6	75	30	24	26	46	—	34	29	1.0	L-4T (4mm)
5730 65206120	-120	1	6	120	41	24	26	46	—	45	29		
5730 65207075	HSK63F -PHC07A-75	1	7	75	30	26	28	46	—	34	29		
5730 65207120	-120	1	7	120	41	26	28	46	—	45	29		
5730 65208075	HSK63F -PHC08A-75	1	8	75	30	26	28	46	—	34	29		
5730 65208120	-120	1	8	120	41	26	28	46	—	45	29		
5730 65209090	HSK63F -PHC09A-90	1	9	90	44	28	30	52	—	50	40		
5730 65209120	-120	1	9	120	64	28	30	52	—	70	40		
5730 65210090	HSK63F -PHC10A-90	1	10	90	44	28	30	52	—	50	40		
5730 65210120	-120	1	10	120	64	28	30	52	—	70	40		
5730 65211090	HSK63F -PHC11A-90	1	11	90	45	30	32	52	—	50	40		
5730 65211120	-120	1	11	120	65	30	32	52	—	70	40		
5730 65212090	HSK63F -PHC12A-90	1	12	90	45	30	32	52	—	50	40		
5730 65212120	-120	1	12	120	65	30	32	52	—	70	40		
5730 65213090	HSK63F -PHC13A-90	1	13	90	46	34	36	52	—	50	40		
5730 65213120	-120	1	13	120	66	34	36	52	—	70	40		
5730 65214090	HSK63F -PHC14A-90	1	14	90	46	34	36	52	—	50	40		
5730 65214120	-120	1	14	120	66	34	36	52	—	70	40		
5730 65215090	HSK63F -PHC15A-90	1	15	90	46	36	38	52	—	50	40		
5730 65215120	-120	1	15	120	66	36	38	52	—	70	40		
5730 65216090	HSK63F -PHC16A-90	1	16	90	46	36	38	52	—	50	40		
5730 65216120	-120	1	16	120	66	36	38	52	—	70	40		
5730 65220090	HSK63F -PHC20A-90	1	20	90	49	40	42	46	—	50	40		
5730 65220120	-120	1	20	120	69	40	42	46	—	70	40		
5730 65225135	HSK63F -PHC25A-135	2	25	135	59	50	52	59	42	60	50		L-6T (6mm)
5730 65225150	-150	2	25	150	79	50	52	59	42	80	50		
5730 65232135	HSK63F -PHC32A-135	2	32	135	42	60	62	85	42	80	65		
5730 65232150	-150	2	32	150	108	60	62	62	42	80	65		

- Favor de utilizar herramientas de corte con una tolerancia menor a h7. Es recomendada una tolerancia menor que 0/-0.01 para nuevas herramientas de corte.
- No dejar el portaherramienta con el tornillo de accionamiento apretado cuando el diámetro interno del portaherramienta se encuentre sin herramienta de corte.
- PHC12A y PHC20A cuentan con orificios de acople de perno, para las boquillas que tienen incluido el perno de retención.

- Please use a cutting tool with a tolerance of less than h7. A tolerance of less than 0/-0.01 is recommended for new cutting tools.
- Do not leave the holder with actuating screw tightened when the chuck is empty.
- PHC12A and PHC20A have pin holes for collet with stopper pin on its body.

Boquilla PHS
PHS Collet

Llave Allen
Hex. Wrench

Pág.114

Pág.099

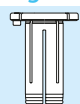

Ejemplo para Ordenar - Ordering Example

HSK63F - PHC 12 A - 135

Interfaz y diámetro
de husillo
Shank size

Diámetro
Interno
I.D. (d)

Longitud de
proyección
Projection length (L)

Torque de apriete (Llave Allen : pág. 520)
Tightening torque (Torque wrench : p.520)

Model Model	I.D. (d) mm	Torque recomendado Tightening torque (Nm)
PHC-A	06 ~ 08	11 ~ 12
PHC-A	09 ~ 20	7 ~ 8
PHC-A	25, 32	29 ~ 30

NOTAS

MN5523·J

Manual Flange

NT-MAPAL Unidad de sujeción - Clamping unit

Cómo instalar

1. Inserte el portaherramienta en el husillo.
2. Gire el anillo de la cubierta.
3. Inserte la llave al perno de sujeción y gírela en dirección a las manecillas del reloj.
4. Quite la llave y cubra el orificio hexagonal para la llave girando el anillo de la cubierta.

How to install

1. Insert the holder into the spindle.
2. Turn the cover ring.
3. Insert the wrench into the clamp bolt and turn it clockwise.
4. Remove the wrench and cover the hex hole for the wrench by turning the cover ring.

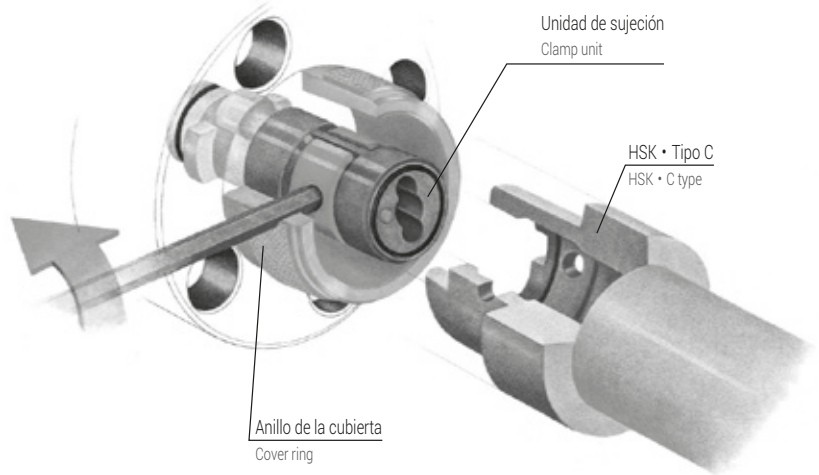

Características - Feature

Rigidez dinámica definitiva Ultimate dynamic rigidity

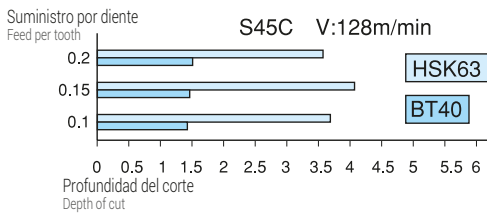
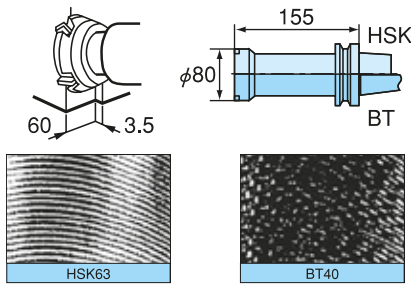

Alta precisión repetitiva High repetitive accuracy

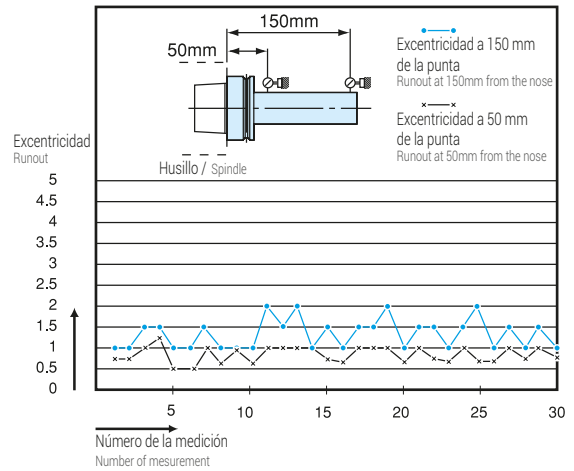

Excelente rigidez estática contra la carga de flexión Excellent static rigidity against bending load

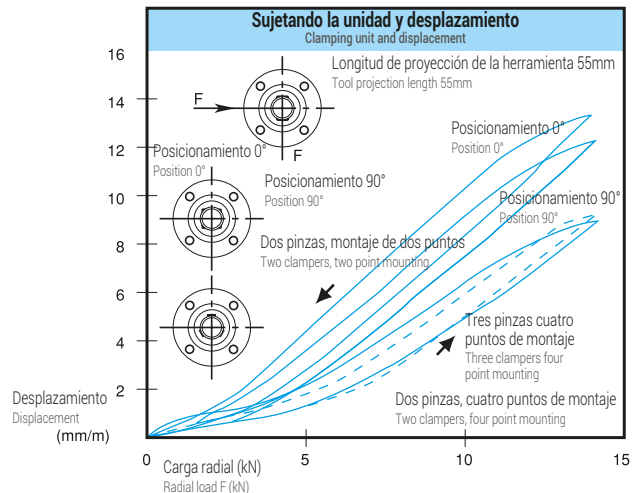
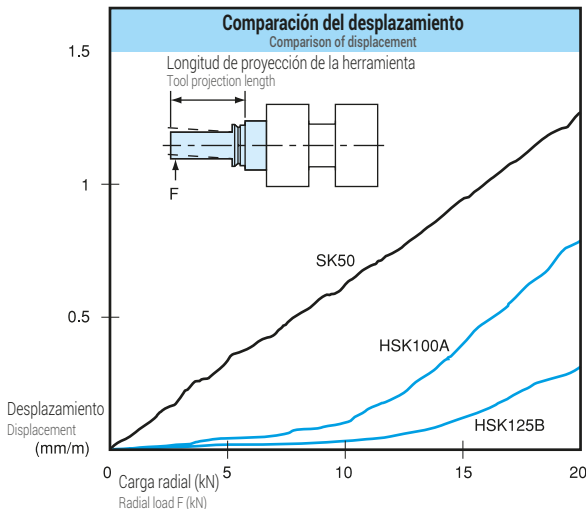

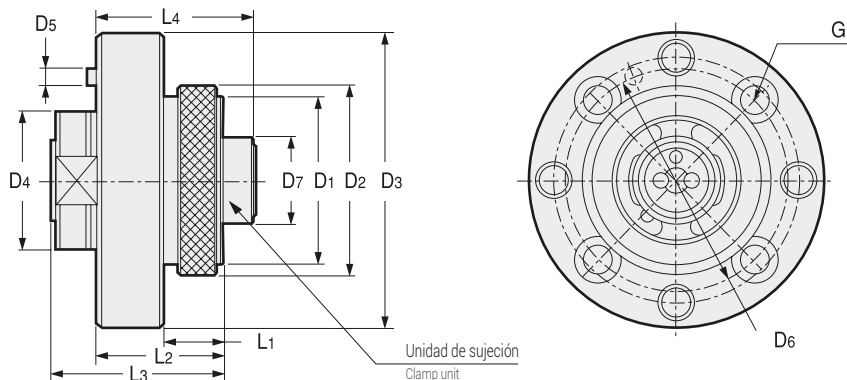

Código Code	Modelo Model	D1	D2	D3	D4 g6	D5	D6	D7	L1	L2	L3	L4	G	Unidad de sujeción adjunta Attached Clamp unit	Zanco HSK adaptado Adapted HSK shank
5500 55230005	MN5523 -05 -J	32	37	60	30	3.5	44	16.6	13	26	36	33.6	M5	KS32-05	HSK32C
5500 55230006	-06 -J	40	45	70	35	4	53	20.6	15	30	41	37.6	M6	KS40-06	HSK40C
5500 55230007	-07 -J	50	55	80	40	4	63	25.6	18	35	46	44.6	M6	KS50-07	HSK50C
5500 55230008	-08 -J	63	70	100	50	4	79	33.6	22	43	55	52.6	M8	KS63-08	HSK63C
5500 55230009	-09 -J	80	87	117	60	5	96	41.6	29	50	63	62.1	M8	KS80-09	HSK80C
5500 55230010	-10 -J	100	110	140	80	5	119	52.6	42	70	83	82	M10	KS100-10	HSK100C

Sólo para el tipo HSK • C
For HSK • C type only.

Ejemplo para Ordenar - Ordering Example

MN5523 - 05 - J

Medida
Size

Dimensiones del husillo para MN5523•J

Spindle Dimensions for MN5523•J

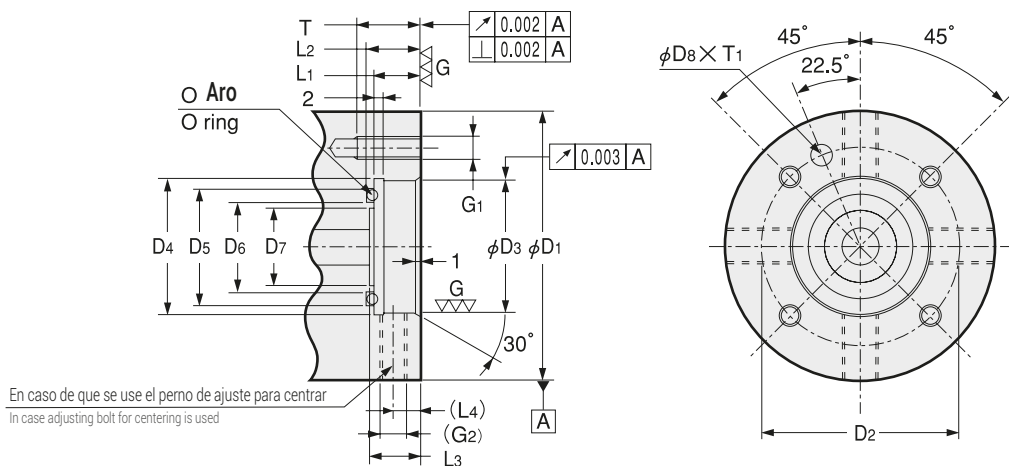

Medida Size	D1	D2 ±0.1	D3 H7	D4	D5	D6	D7	D8	O Aro O ring	L1 +0.2 +0.1	L2 +0.1 0	L3	(L4)	G1	(G2)	T	T1 +0.5 0
HSK32	60	44	30 ^{+0.021} ₀	30.5	26	20.3	—	4.5	P22	10	11.8	—	6	M5 × 0.8	M6 × 1	11	3
HSK40	70	53	35 ^{+0.025} ₀	35.5	32	23.6	20	5.0	P26	10	12.7	12	6	M6 × 1	M6 × 1	14	3.5
HSK50	80	63	40 ^{+0.025} ₀	40.5	37	28.6	23	5.0	P31	10	12.7	12	6	M6 × 1	M6 × 1	14	3.5
HSK63	100	79	50 ^{+0.025} ₀	50.5	37	28.6	—	5.0	P31	12	14.7	—	8	M8 × 1.25	M8 × 1	15	3.5
HSK80	117	96	60 ^{+0.030} ₀	60.5	50	41.6	28	6.0	P44	12	14.7	14	8	M8 × 1.25	M8 × 1	15	4.5
HSK100	140	119	80 ^{+0.030} ₀	80.5	56	47.6	—	6.0	P50	13	15.7	—	8	M10 × 1.5	M10 × 1	18	4.5

BT
CAT
AHO
HSK-A/E/F/C
HSK-T
C
UTS
Máquinas Especializadas Specialized Machine
Equipo Relacionado Related Equipment
Taladro de Biselado & de Casquillo Bush & Chamfering Drill
Milling Chuck
Collet Holder
"R" Zero Holder
Hydraulic Chuck
Shrink Fit
Tapping Chuck
Arbors
Function Holder
HSK-E
HSK-F
HSK-C
Dimensions

HSK Tipo A - HSK Type A

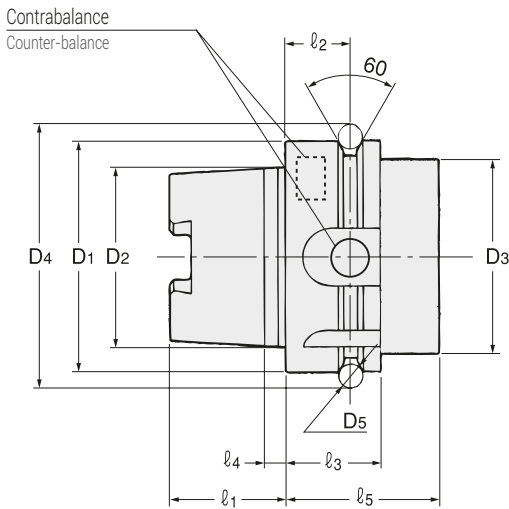

Medida size	D1	D2	D3 (Max.)	D4	D5	l1	l2	l3	l4	l5
HSK32A	32	24	26	37.0	4	16	16	20	3.2	35
HSK40A	40	30	34	45.0	4	20	16	20	4.0	35
HSK50A	50	38	42	59.3	7	25	18	26	5.0	42
HSK63A	63	48	53	72.3	7	32	18	26	6.3	42
HSK80A	80	60	68	88.8	7	40	18	26	8.0	42
HSK100A	100	75	85	109.75	7	50	20	29	10.0	45
HSK125A	125	95	111	134.75	7	63	20	29	12.5	45
HSK160A	160	120	144	169.75	7	80	22	31	16.0	47

- 1.El HSK tipo A de NT no tiene barreno de cambio manual ni chip ID.
 - 2.El HSK tipo A de NT tiene un orificio y un nodo para hacer contrabalance.
- 1.NT's HSK Type A has neither manual clamping hole nor ID chip hole.
2.NT's HSK Type A has both notch and hole for counter-balancing.

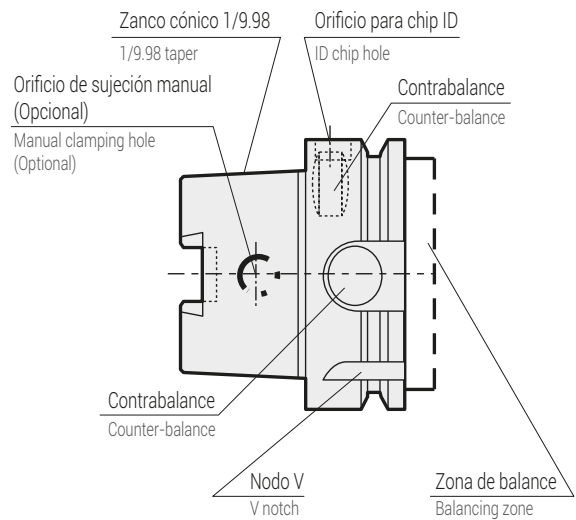
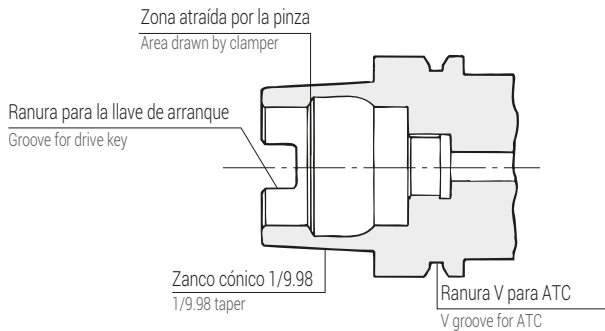

	DIN	ISO	NT
Orificio para chip ID ID chip hole	Sí / Yes	No-No	No-No
Nodo V "V" notch	Sí / Yes	Sí / Yes	Sí / Yes
Barreno de cambio manual Manual clamping hole	Sí / Yes	Sí / Yes	No-No
Contrabalanceo Counter balancing	—	Sí / Yes	Sí / Yes

Formas y características

Shapes and features

Los tipos A y C no estaban archivados como de estándar ISO y DIN.
Se muestran 6 tipos. Los tipos A y B no tienen barreno de cambio manual.

A and C types were unified as ISO and DIN standard.

6 types are shown. A and B types have no manual clamping hole.

Tipo A - Type A

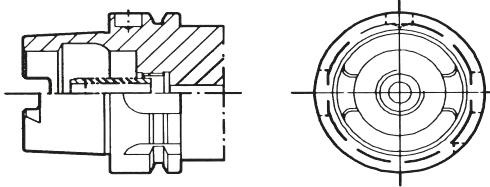

- Aplicación: centros de maquinado.
- Orificio de refrigeración a través del centro.
- Transmisión de torque con llaves para encender en el reborde.
- Las ranuras U para el nodo de posicionamiento ATC.
- Orificio de suspensión de la herramienta DI (opcional).
- Application : Machining centres.
- Centre through coolant hole.
- Torque transmission with drive keys on flange.
- U grooves for ATC positioning notch.
- Tool ID recess hole (optional).

Tipo C - Type C

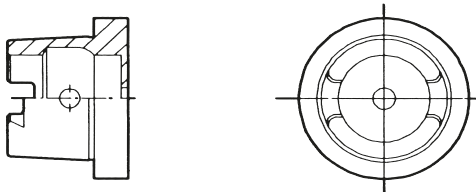

- Aplicación: Líneas de transferencia y máquinas con propósitos especiales sin ATC.
- Orificio de refrigeración a través del centro.
- Transmisión de torque con llave en el reborde.
- Application : Transfer lines and special purpose machines without ATC.
- Centre through coolant hole.
- Torque transmission with drive keys on flange.

Tipo E - Type E

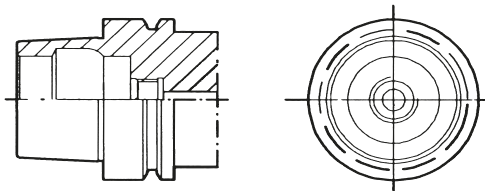

- Aplicación: Centros de mecanizado de alta velocidad.
- Forma simétrica completa sin llave.
- Transmisión de torque por fricción.
- Orificio de refrigerante a través del centro (opcional).
- Application : High speed machining centres.
- Complete symmetrical shape without drive keys.
- Torque transmission by friction.
- Centre through coolant hole. (Optional)

Tipo - Type B

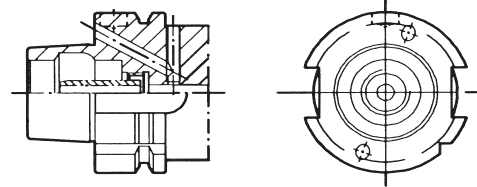

- Aplicación: centros de maquinado, máquinas de fresado, tornos, etcétera.
- Diámetro amplio en reborde.
- Reborde a través del orificio de refrigerante o del orificio de refrigerante a través del centro.
- Transmisión de torque a través de las ranuras U en el reborde.
- Nodo de posicionamiento.
- Orificio de suspensión de la herramienta DI (opcional).
- Application : Machining centres, milling machines, lathes etc.
- Large flange diameter.
- Flange through coolant hole or centre through coolant hole.
- Torque transmission by U grooves on flange.
- Positioning notch.
- Tool ID recess hole (optional).

Tipo D - Type D

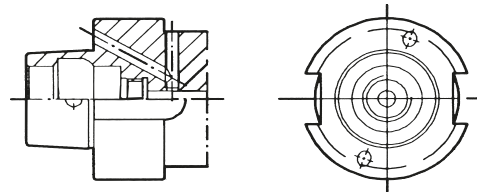

- Aplicación: Líneas de transferencia y máquinas con propósitos especiales sin ATC.
- Diámetro amplio en reborde.
- Reborde a través del orificio de refrigerante.
- Transmisión de torque a través de las ranuras U en el reborde.
- Application : Transfer lines and special purpose machines without ATC.
- Large flange diameter.
- Flange through coolant hole.
- Torque transmission by U grooves on flange.

Tipo F - Type F

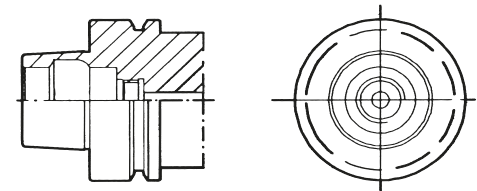

- Aplicación: Centros de mecanizado de alta velocidad.
- Diámetro amplio en reborde.
- Orificio de refrigerante a través del centro (opcional).
- Application : High speed machining centres.
- Large flange diameter.
- Centre through coolant hole. (Optional)

¿Qué es HSK-T? - What is HSK-T?

La interfaz HSK-T se desarrolló para maximizar la habilidad de corte de las máquinas multitareas.
 La interfaz HSK-T obtuvo el estándar ISO (ISO121 164-3:2008) en el 2008.
 HSK-T interface was developed to maximize cutting ability of multi-tasking machines.
 HSK-T interface became ISO standard (ISO121 164-3:2008) in 2008.

Características - Features

Compatible con el HSK-A - Compatible with HSK-A

El zanco HSK-T es compatible con el zanco HSK-A que se usa en los centros de maquinado.

HSK-T shank is compatible with HSK-A shank that is used for machining centers.

¿Qué es la máquina multitareas?

La máquina multitareas combina los procesos de fresado y de torneado en una misma máquina, los cuales se procesaban convencionalmente en varias máquinas.
 Multi-tasking machine combines milling and turning processes, which were conventionally processed on multiple machines, onto one machine.

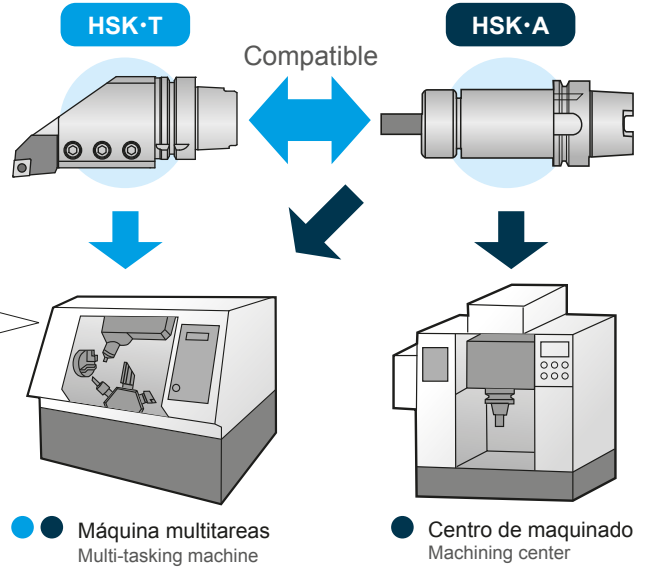
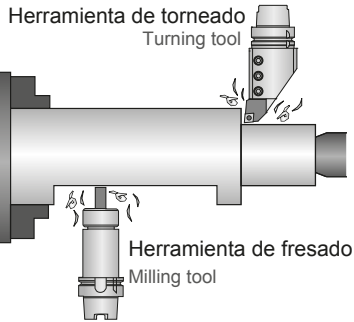

Precisión del corte aumentada en el proceso de torneado - Increased cutting accuracy at turning process

El zanco HSK-T se diseñó para minimizar el espacio entre la llave y la clavija. Como consecuencia, se sostuvo con exactitud la altura del borde de corte y se mejoró la precisión del corte. También se realizó el diámetro de corte invariable.

HSK-T shank was designed to minimize the gap between the key and key way. Consequently, cutting edge height was sustained accurately and cutting accuracy was improved. Invariant cutting diameter was realized as well.

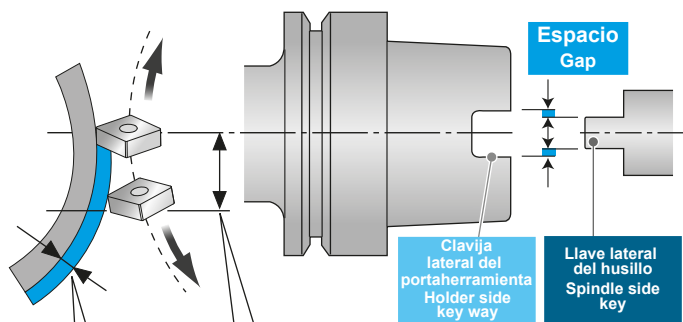

El espacio genera diámetros variados en el corte.
 En $\phi 50$ se muestra un ejemplo.
 The gap causes variant cutting diameters.
 Example at $\phi 50$
 HSK63T : $3\mu\text{m}$ HSK63A : $14\mu\text{m}$

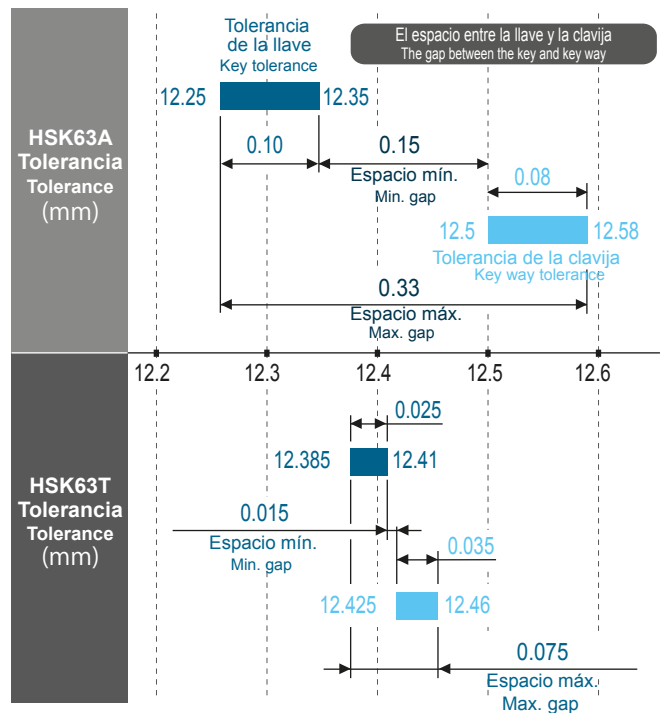

- Para el Exterior / Retazo
- For External / Cut-off

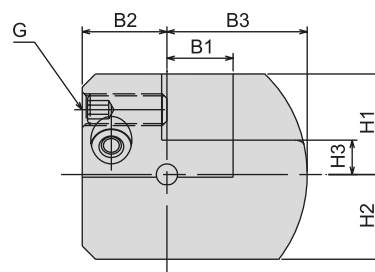
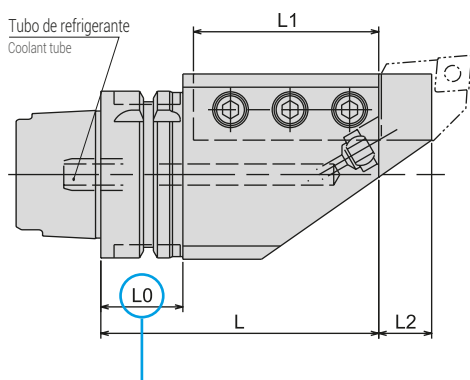

⚠ Precaución / Caution
 ★ Tome precauciones con la interferencia del brazo del A.T.C. (automatic tool charger) y el cartucho de herramientas.
 ★ Take caution against A.T.C. arm and tool magazine interference.

Se muestra el dibujo de la mano izquierda
 Right-hand drawing shown

- Tubo de refrigerante incluido.
- Coolant tube is included.

Medidas Métricas - Metric Sizes

Unidad : Métrico
 Unit : Metric

Código Code	Modelo Model	L	L1	L2	B1	B2	B3	H1	H2	H3	L0	G	Kg
590004040095	HSK50T -SBV2020 R -95	95	60	15	20	25	43.5	25	25	5	31	M10	2
590004041095	L -95	95	60	15	20	25	43.5	25	25	5	31	M10	2
590005040095	HSK63T -SBV2020 R -95	95	60	15	20	32	43.5	33	32	13	32	M10	2.7
590005041095	L -95	95	60	15	20	32	43.5	33	32	13	32	M10	2.7
590005050105	-SBV2525 R -105	105	70	20	25	32	45	30	30	5	32	M12	2.9
590005051105	L -105	105	70	20	25	32	45	30	30	5	32	M12	2.9
590007050150	HSK100T -SBV2525 R -150	150	110	20	25	37	59	48	43	23	35	M12	8.5
590007051150	L -150	150	110	20	25	37	59	48	43	23	35	M12	8.5
590007060150	-SBV3232 R -150	150	110	20	32	40	68.5	45	43	15	35	M14	9
590007061150	L -150	150	110	20	32	40	68.5	45	43	15	35	M14	9

Ejemplo para Ordenar - Ordering Example

HSK63T - SBV 2020 R - 95

Interfaz y diámetro de husillo

Shank size

- Mano izquierda - L
- Mano derecha - R
- Left hand - L
- Right hand - R

Longitud de proyección

Projection length (L)

SBN

HSK-T Turning Tools

MORI SEIKI CO., LTD otorga a NT TOOL una licencia de fabricación y distribución de producto bajo la patente No.3720202.
MORI SEIKI CO.,LTD granted NT TOOL a manufacturing and distribution license under the patent No.3720202.

- Para el Exterior / Refrentado
- For External / Facing

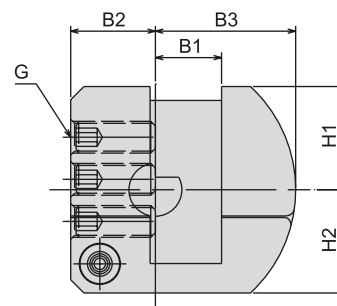
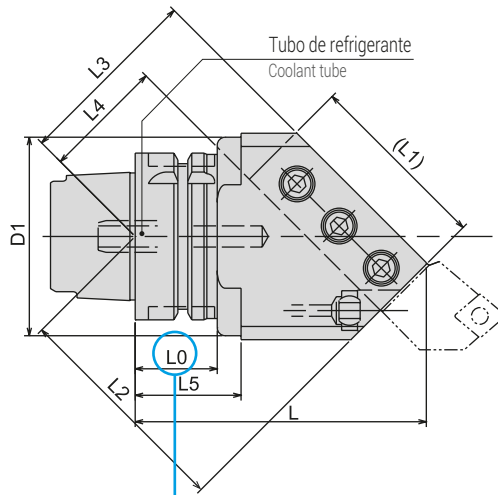

Precaución / Caution
 ★ Tome precauciones con la interferencia del brazo del A.T.C. (automatic tool changer) y el cartucho de herramientas.
 ★ Take caution against A.T.C. arm and tool magazine interference.

Se muestra el dibujo de la mano derecha
 Right-hand drawing shown
 ● Tubo de refrigerante incluido.
 ● Coolant tube is included.

Medidas Métricas - Metric Sizes

Unidad : Métrico
 Unit : Metric

Código Code	Modelo Model	L	(L1)	L2	L3	L4	L5	D1	B1	B2	B3	H1	H2	L0	G	Kg
590004240110	HSK50T -SBN2020 R -110	110	60	83.1	72.8	52.8	-	-	20	25	43.5	35	35	31	M10	2.4
590004241110	L -110	110	60	83.1	72.8	52.8	-	-	20	25	43.5	35	35	31	M10	2.4
590005240110	HSK63T -SBN2020 R -110	110	60	83.1	72.8	52.8	-	-	20	32	43.5	35	35	32	M10	2.9
590005241110	L -110	110	60	83.1	72.8	52.8	-	-	20	32	43.5	35	35	32	M10	2.9
590005250110	-SBN2525 R -110	110	70	85.2	70.8	45.8	40	90	25	32	53	39	39	32	M12	3.2
590005251110	L -110	110	70	85.2	70.8	45.8	40	90	25	32	53	39	39	32	M12	3.2
590007250135	HSK100T -SBN2525 R -135	135	70	102.9	88.5	63.5	-	-	25	32	59	43	43	35	M12	6.4
590007251135	L -135	135	70	102.9	88.5	63.5	-	-	25	32	59	43	43	35	M12	6.4
590007260140	-SBN3232 R -140	140	85	109.9	89	59	-	-	32	37	68.5	48	43	35	M14	7.2
590007261140	L -140	140	85	109.9	89	59	-	-	32	37	68.5	48	43	35	M14	7.2

- 1.La dirección de la boquilla del refrigerante se puede ajustar. (Puede ser que el refrigerante no alcance el borde de corte adecuadamente, según la forma de la punta).
 - 2.Favor de acortar una punta cuadrada si es necesario.
 - 3.El tipo HSK-T no tiene barreno de cambio manual ni cavidad para chip DI.
- 1.Direction of coolant nozzle can be adjusted. (Coolant may not reach the cutting edge properly depending on the bit shape)
 - 2.Please shorten a square bit if necessary.
 - 3.HSK-T type has no manual clamping hole and ID chip recess.

Ejemplo para Ordenar - Ordering Example

HSK63T - SBN 2020 R - 110

Interfaz y diámetro de husillo
 Shank size

□ Mano izquierda - L
 □ Mano derecha - R
 □ Left hand - L
 □ Right hand - R

Longitud de proyección
 Projection length (L)

- Para Refrentado
- For Facing

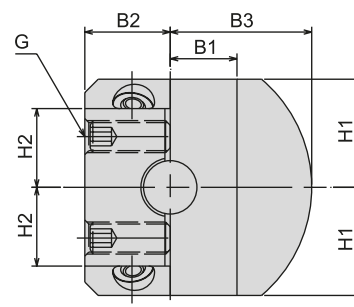
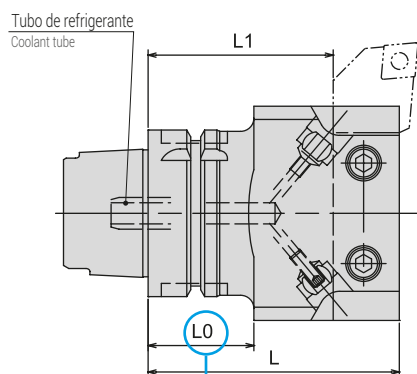

⚠ Precaución / Caution
 ★ Tome precauciones con la interferencia del brazo del A.T.C. (automatic tool changer) y el cartucho de herramientas.
 ★ Take caution against A.T.C. arm and tool magazine interference.

Mano izquierda y derecha, para ambos
 For both Right and Left-hand
 ● Tubo de refrigerante incluido.
 ● Coolant tube is included.

Medidas Métricas - Metric Sizes

Unidad : Métrico
 Unit : Metric

Código Code	Modelo Model	L	L1	B1	B2	B3	H1	H2	L0	G	Kg
590004342090	HSK50T -SBH2020 N -90	90	70	20	25	43.5	27.5	—	40	M10	1.8
590004342120	N -120	120	100	20	25	43.5	27.5	—	70	M10	2.3
590005342090	HSK63T -SBH2020 N -90	90	70	20	32	43.5	30	—	40	M10	2.5
590005352090	-SBH2525 N -90	90	65	25	32	53	40.5	29.5	40	M12	3.0
590005352120	N -120	120	95	25	32	53	40.5	29.5	70	M12	3.7
590007352105	HSK100T -SBH2525 N -105	105	80	25	32	59	48	37	35	M12	6.1
590007352150	N -150	150	125	25	32	59	48	37	35	M12	8.9
590007362105	-SBH3232 N -105	105	75	32	40	68.5	57	43	35	M14	7.4

1. La dirección de la boquilla del refrigerante se puede ajustar. (Puede ser que el refrigerante no alcance el borde de corte adecuadamente, según la forma de la punta).
 2. Favor de acortar una punta cuadrada si es necesario.
 3. Se incluye un tornillo sellador para la boquilla del refrigerante (M5x15)
 4. El tipo HSK-T no tiene barreno de cambio manual ni cavidad para chip DI.
1. Direction of coolant nozzle can be adjusted. (Coolant may not reach the cutting edge properly depending on the bit shape)
 2. Please shorten a square bit if necessary.
 3. One plug screw for coolant nozzle (M5x15) is included.
 4. HSK-T type has no manual clamping hole and ID chip recess.

Ejemplo para Ordenar - Ordering Example

HSK63T - SBV 2020N - 90

Interfaz y
diámetro de
husillo

Shank size

Longitud de
proyección

Projection
length (L)

SBT

HSK-T Turning Tools

- For External / Facing
- For External / Facing

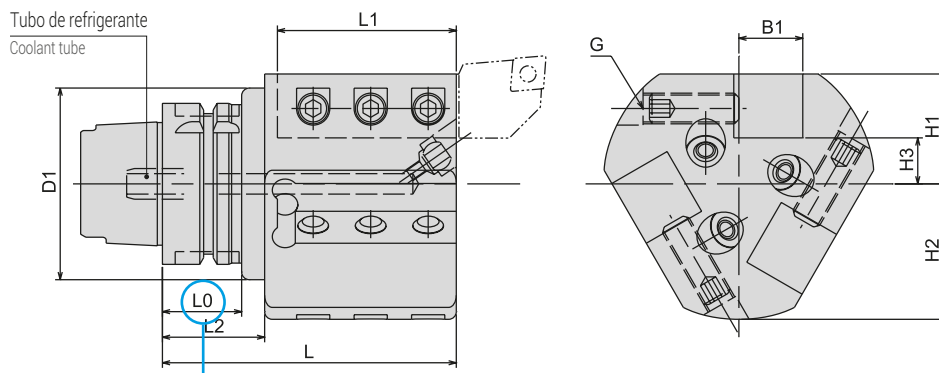
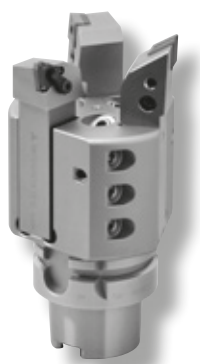

⚠ Precaución / Caution
 ★ Tome precauciones con la interferencia del brazo del A.T.C. (automatic tool changer) y el cartucho de herramientas.
 ★ Take caution against A.T.C. arm and tool magazine interference.

Se muestra el dibujo de la mano derecha
 Right-hand drawing shown

- Tubo de refrigerante incluido.
- Coolant tube is included.

Medidas Métricas - Metric Sizes

Unidad : Métrico
 Unit : Metric

Código Code	Modelo Model	L	L1	L2	D1	B1	H1	H2	H3	L0	G	Kg
590004140095	HSK50T -SBT2020 R -95	95	60	—	—	20	35	43.5	15	31	M10	2.3
590004141095	L -95	95	60	—	—	20	35	43.5	15	31	M10	2.3
590005140095	HSK63T -SBT2020 R -95	95	60	—	—	20	35	43.5	15	32	M10	2.6
590005141095	L -95	95	60	—	—	20	35	43.5	15	32	M10	2.6
590005150115	-SBT2525 R -115	115	70	40	90	25	43	53	18	32	M12	4.4
590005151115	L -115	115	70	40	90	25	43	53	18	32	M12	4.4
590007150150	HSK100T -SBT2525 R -150	150	110	—	—	25	48	59	23	35	M12	8.9
590007151150	L -150	150	110	—	—	25	48	59	23	35	M12	8.9

1. La dirección de la boquilla del refrigerante se puede ajustar. (Puede ser que el refrigerante no alcance el borde de corte adecuadamente, según la forma de la punta).
 2. Favor de acortar una punta cuadrada si es necesario.
 3. Se incluye un tornillo sellador para la boquilla del refrigerante (M5x15)
 4. El tipo HSK-T no tiene barreno de cambio manual ni cavidad para chip ID.
1. Direction of coolant nozzle can be adjusted. (Coolant may not reach the cutting edge properly depending on the bit shape)
 2. Please shorten a square bit if necessary.
 3. One plug screw for coolant nozzle (M5x15) is included.
 4. HSK-T type has no manual clamping hole and ID chip recess.

Ejemplo para Ordenar - Ordering Example

HSK63T - SBT 2020 R - 95

Interfaz y diámetro de husillo

Shank size

- Mano izquierda - L
- Mano derecha - R

- Left hand - L
- Right hand - R

Longitud de proyección

Projection length (L)

- Para la barra mandriladora
- For Boring bar

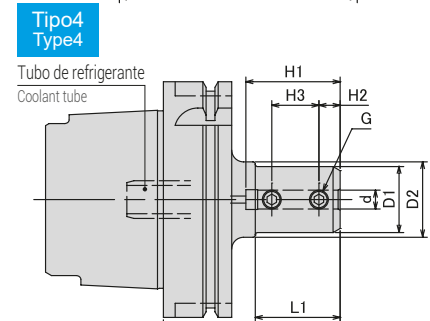
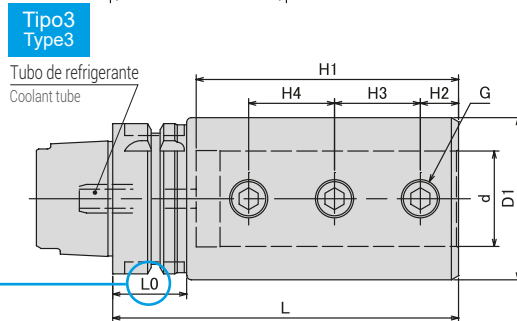
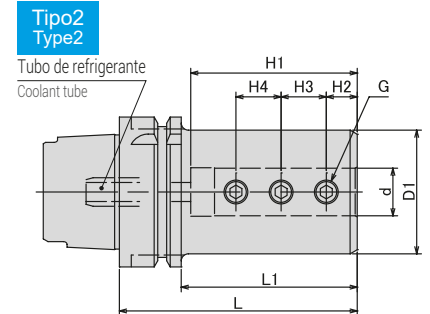
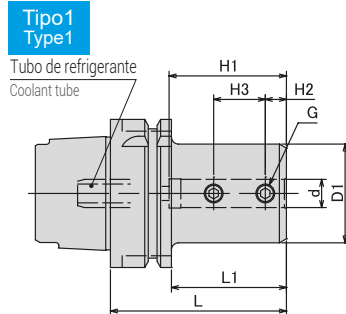

⚠ Precaución / Caution
 ★ Tome precauciones con la interferencia del brazo del A.T.C. (automatic tool changer) y el cartucho de herramientas.
 ★ Take caution against A.T.C. arm and tool magazine interference.

- Tubo de refrigerante incluido.
- Coolant tube is included.

Medidas Métricas - Metric Sizes Unidad : Métrico Unit : Metric

Código Code	Modelo Model	Tipo Type	d	L	L1	D1	D2	H1	H2	H3	H4	L0	G	Kg
591004008065	HSK50T -TSB8 -65	1	8	65	39	28	—	40	9	20	—	—	M8	0.7
591004010070	-TSB10 -70	1	10	70	44	35	—	45	9	22	—	—	M8	0.8
591004012075	-TSB12 -75	1	12	75	49	42	—	50	9	22	—	—	M8	1
591004016095	-TSB16 -95	2	16	95	69	48	—	70	14	18	18	—	M10	1.3
591004020095	-TSB20 -95	3	20	95	—	52	—	70	14	18	18	31	M10	1.4
591004025110	-TSB25 -110	3	25	110	—	62	—	85	14	26	26	31	M12	2.1
591004032125	-TSB32 -125	3	32	125	—	62	—	100	14	30	30	31	M12	2.1
591005008065	HSK63T -TSB8 -65	1	8	65	39	28	—	40	9	20	—	—	M8	0.9
591005010070	-TSB10 -70	1	10	70	44	35	—	45	9	22	—	—	M8	1.1
591005012075	-TSB12 -75	1	12	75	49	42	—	50	9	22	—	—	M8	1.2
591005016100	-TSB16 -100	2	16	100	74	48	—	70	14	18	18	—	M10	1.7
591005020100	-TSB20 -100	2	20	100	74	52	—	70	14	18	18	—	M10	1.8
591005025115	-TSB25 -115	2	25	115	89	62	—	85	14	26	26	—	M12	2.5
591005032130	-TSB32 -130	2	32	130	104	62	—	100	14	30	30	—	M12	2.6
591005040145	-TSB40 -145	3	40	145	—	68	—	115	16	36	36	32	M16	2.9
591007008075	HSK100T -TSB8 -75	4	8	75	36	28	32	40	9	20	—	—	M8	2.4
591007010080	-TSB10 -80	1	10	80	51	35	—	45	9	22	—	—	M8	2.5
591007012085	-TSB12 -85	1	12	85	56	42	—	50	9	22	—	—	M8	2.7
591007016105	-TSB16 -105	2	16	105	76	48	—	70	14	18	18	—	M10	3.1
591007020105	-TSB20 -105	2	20	105	76	52	—	70	14	18	18	—	M10	3.2
591007025120	-TSB25 -120	2	25	120	91	62	—	85	14	26	26	—	M12	4
591007032135	-TSB32 -135	2	32	135	106	72	—	100	14	30	30	—	M12	4.9
591007040150	-TSB40 -150	2	40	150	121	82	—	115	16	36	36	—	M16	6
591007050180	-TSB50 -180	2	50	180	151	92	—	145	18	38	38	—	M16	7.8

1. Se pueden sujetar varias medidas de barras mandriladoras con la funda reductora de medida / refrigerante, TSS con TSB40.
2. El tipo HSK-T no tiene barrenado de cambio manual ni cavidad para chip DI.
1. Various sizes of boring bar can be clamped by using the coolant/size reduction sleeve, TSS with TSB40.
2. HSK-T type has no manual clamping hole and ID chip recess.

Ejemplo para Ordenar - Ordering Example

HSK63T	- TSB	10	-	70
Interfaz y diámetro de husillo Shank size		Diámetro Interior I.D. (d)		Longitud de proyección Projection length (L)



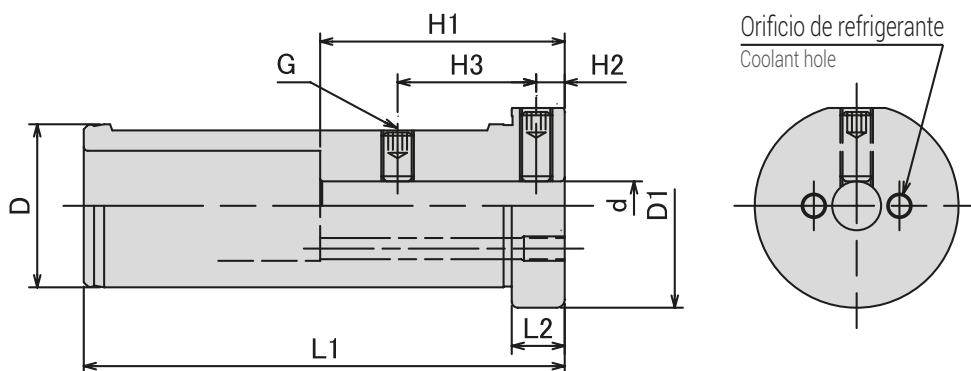

Manga reductora de medida/refrigerante para TSB40
Coolant/Size Reduction Sleeve for TSB40

TSS

Medidas Métricas - Metric Sizes

Unidad : Métrico
Unit : Metric

Código Code	Modelo Model	d	L1	L2	D	D1	H1	H2	H3	G	Kg
591400004008	TSS 40 - 8	8	118	13	40	50	50	7	34	M8	1
591400004010	-10	10	118	13	40	50	50	7	34	M8	1
591400004012	-12	12	118	13	40	50	60	7	34	M8	1
591400004016	-16	16	118	13	40	50	70	7	34	M8	0.9

- 1.El TSS sólo se puede usar con el TSB40.
- 2.Para usar el refrigerante, conecte uno de los dos orificios de refrigerante con el tornillo sellador.
- 3.Incluye un tornillo sellador para el orificio de refrigerante (M6x10).
- 4.Se pueden sujetar varias barras mandriladoras con la manga reductora de medida/refrigerante, TSS con TSB40.

- 1.TSS can be used for TSB40 only.
- 2.For coolant use, plug one of two coolant holes with plug screw.
- 3.One plug screw for coolant hole (M6x10) is included.
- 4.Various sizes of boring bar can be clamped by using the coolant/size reduction sleeve, TSS with TSB40.

Ejemplo para Ordenar - Ordering Example

TSS 40 - 10
 Diámetro Interior I.D. (d) Longitud de proyección Projection length (L)

- Para el taladro
- For Drill

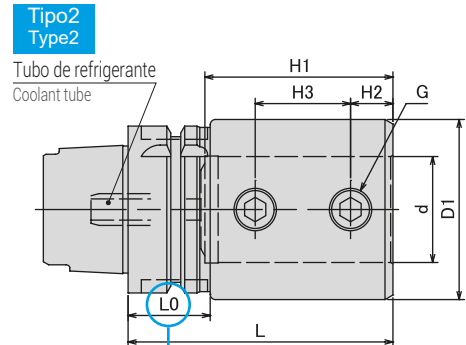
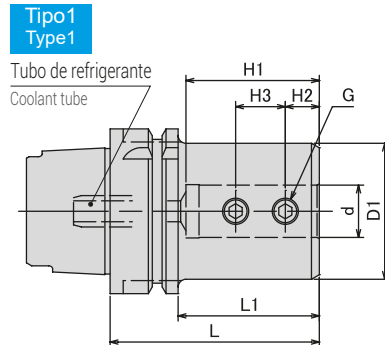

- Tubo de refrigerante incluido.
- Coolant tube is included.

⚠ Precaución / Caution
 ★ Tome precaución con la interferencia del brazo del A.T.C. (automatic tool changer) y el cartucho de herramientas.
 ★ Take caution against A.T.C. arm and tool magazine interference.

Medidas Métricas - Metric Sizes

Unidad : Métrico
Unit : Metric

Código Code	Modelo Model	Tipo Type	d	L	L1	D1	H1	H2	H3	L0	G	Kg
591004116075	HSK50T -TSD16 -75	1	16	75	49	48	49	14	18	—	M10	1.1
591004120080	-TSD20 -80	2	20	80	—	52	51	14	18	31	M10	1.2
591004125085	-TSD25 -85	2	25	85	—	62	57	14	26	31	M12	1.6
591004132090	-TSD32 -90	2	32	90	—	62	61	14	30	31	M12	1.6
591005116075	HSK63T -TSD16 -75	1	16	75	49	48	49	14	18	—	M10	1.4
591005120080	-TSD20 -80	1	20	80	54	52	51	14	18	—	M10	1.5
591005125085	-TSD25 -85	1	25	85	59	62	57	14	26	—	M12	1.9
591005132090	-TSD32 -90	1	32	90	64	62	61	14	30	—	M12	1.9
591005140100	-TSD40 -100	2	40	100	—	68	71	16	36	32	M16	2.1
591007116085	HSK100T -TSD16 -85	1	16	85	56	48	49	14	18	—	M10	2.9
591007120085	-TSD20 -85	1	20	85	56	52	51	14	18	—	M10	2.9
591007125090	-TSD25 -90	1	25	90	61	62	57	14	26	—	M12	3.3
591007132095	-TSD32 -95	1	32	95	66	72	61	14	30	—	M12	3.9
591007140105	-TSD40 -105	1	40	105	76	82	71	16	36	—	M16	4.6
591007150115	-TSD50 -115	1	50	115	86	92	81	18	38	—	M16	5.3

1. La herramienta de corte podría no estar sujeta según la posición y/o la forma de la llave en el zanco de la herramienta de corte. Favor de revisar la dimensión de la herramienta de corte, incluyendo la ubicación de los tornillos de fijación.
2. El tipo HSK-T no tiene barreno de cambio manual, ni cavidad para chip ID.

1. Cutting tool may not be clamped depending on the position and/or shape of flat on the cutting tool shank. Please check dimension of the cutting tool including location for setscrews.
2. HSK-T type has no manual clamping hole and ID chip recess.

Ejemplo para Ordenar - Ordering Example

HSK63T - TSD 25 - 85

Interfaz y diámetro de husillo
Shank size

Diámetro Interior
I.D. (d)

Longitud de proyección
Projection length (L)

NOTAS

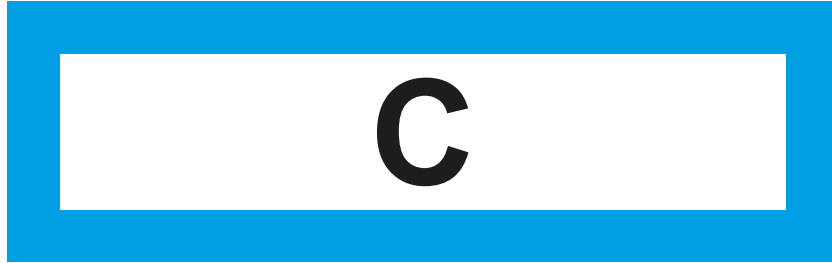

SISTEMA DE HERRAMENTADO DEL ZANCO POLIGONAL

POLYGON TAPER SHANK TOOLING SYSTEM

※Para más detalles con respecto al herramientado de zanco polygonal NC, por favor contactarnos directamente.

※For details regarding NC Tooling with Polygon Taper shanks, please contact us directly.

HDC•A

High-Precision Collet Holder

- Adecuado para barrenado, rima y acabado en fresa
- Suitable for drilling, reaming and finish endmilling.

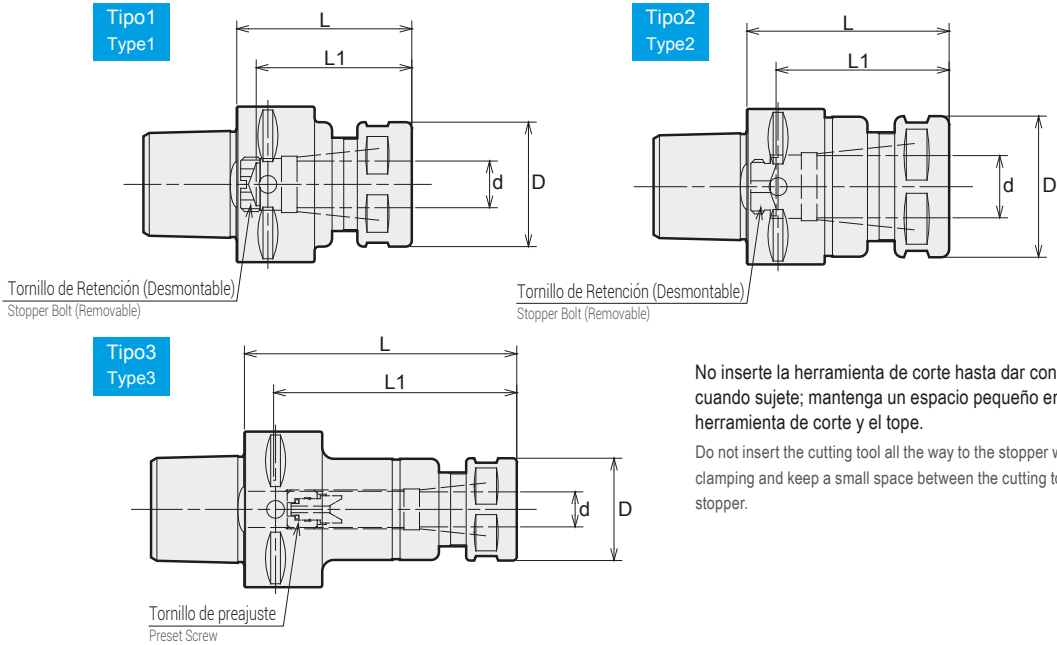

Código Code	Modelo Model	Tipo Type	d	L	L1	D1	Tuerca ciega Nut	kg	Boquilla Collet	Llave Inglesa Spanner
6700 00307035	C3 -HDC07A -35	1	0.5-7.0	35	24	23	HDP-07A	0.2	FDC-07	S-0
6700 00307045	-45	1	0.5-7.0	45	34	23	HDP-07A	0.2	FDC-07	S-0
6700 00309035	-HDC09A -35	*2	2.5-9.0	35	29	26	HDP-09	0.2	FDC-09	S-1L
6700 00309045	-45	1	2.5-9.0	45	34	26	HDP-09	0.2	FDC-09	S-1L
6700 00312036	-HDC12A -36	*2	2.5-12.0	36	31	32	HDP-12	0.2	FDC-12	S-3L
6700 00312045	-45	*2	2.5-12.0	45	37	32	HDP-12	0.3	FDC-12	S-3L
6700 00316045	-HDC16A -45	*2	3.5-16.0	45	37	36	HDP-16	0.3	FDC-16	S-4L
6700 00407035	C4 -HDC07A -35	*1	0.5-7.0	35	24	23	HDP-07A	0.3	FDC-07	S-0
6700 00407045	-45	1	0.5-7.0	45	34	23	HDP-07A	0.4	FDC-07	S-0
6700 00407052	-52	3	0.5-7.0	52	22-29	23	HDP-07A	0.4	FDC-07	S-0
6700 00407070	-70	3	0.5-7.0	70	22-45	23	HDP-07A	0.4	FDC-07	S-0
6700 00409035	-HDC09A -35	*1	2.5-9.0	35	24	26	HDP-09	0.3	FDC-09	S-1L
6700 00409045	-45	1	2.5-9.0	45	34	26	HDP-09	0.4	FDC-09	S-1L
6700 00409052	-52	1	2.5-9.0	52	41	26	HDP-09	0.4	FDC-09	S-1L
6700 00409070	-70	3	2.5-9.0	70	27-45	26	HDP-09	0.5	FDC-09	S-1L
6700 00412035	-HDC12A -35	*1*2	2.5-12.0	35	31	32	HDP-12	0.3	FDC-12	S-3L
6700 00412045	-45	*2	2.5-12.0	45	38	32	HDP-12	0.4	FDC-12	S-3L
6700 00412052	-52	1	2.5-12.0	52	40	32	HDP-12	0.4	FDC-12	S-3L
6700 00412070	-70	3	2.5-12.0	70	33-45	32	HDP-12	0.5	FDC-12	S-3L
6700 00416038	-HDC16A -38	*1*2	3.5-16.0	38	36	36	HDP-16	0.3	FDC-16	S-4L
6700 00416052	-52	*2	3.5-16.0	52	44	36	HDP-16	0.4	FDC-16	S-4L
6700 00422054	-HDC22A -54	*2	3.5-22.0	54	47	46	HDP-22	0.5	FDC-22	S-5L
6700 00507060	C5 -HDC07A -60	1	0.5-7.0	60	47	23	HDP-07A	0.6	FDC-07	S-0
6700 00507075	-75	3	0.5-7.0	75	22-37	23	HDP-07A	0.6	FDC-07	S-0
6700 00507105	-105	3	0.5-7.0	105	22-45	23	HDP-07A	0.7	FDC-07	S-0
6700 00507135	-135	3	0.5-7.0	135	22-45	23	HDP-07A	0.8	FDC-07	S-0

Código Code	Modelo Model	Tipo Type	d	L	L1	D1	Tuerca ciega Nut	kg	Boquilla Collet	Llave Inglesa Spanner
6700 00509060	-HDC09A -60	1	2.5-9.0	60	47	26	HDP-09	0.6	FDC-09	S-1L
6700 00509075	-75	3	2.5-9.0	75	27-37	26	HDP-09	0.7		
6700 00509105	-105	3	2.5-9.0	105	27-57	26	HDP-09	0.8		
6700 00509135	-135	3	2.5-9.0	135	27-57	26	HDP-09	0.9		
6700 00512060	-HDC12A -60	1	2.5-12.0	60	43	32	HDP-12	0.6	FDC-12	S-3L
6700 00512075	-75	1	2.5-12.0	75	58	32	HDP-12	0.7		
6700 00512105	-105	3	2.5-12.0	105	33-69	32	HDP-12	0.9		
6700 00512135	-135	3	2.5-12.0	135	33-69	32	HDP-12	1.0		
6700 00516060	-HDC16A -60	1	3.5-16.0	60	38	36	HDP-16	0.7	FDC-16	S-4L
6700 00516075	-75	1	3.5-16.0	75	53	36	HDP-16	0.8		
6700 00516105	-105	3	3.5-16.0	105	38-73	36	HDP-16	1.0		
6700 00516135	-135	3	3.5-16.0	135	38-82	36	HDP-16	1.2		
6700 00516150	-150	3	3.5-16.0	150	38-82	36	HDP-16	1.3	FDC-22	S-5L
6700 00522075	-HDC22A -75	2	3.5-22.0	75	57	46	HDP-22	0.9		
6700 00522105	-105	3	3.5-22.0	105	47-68	46	HDP-22	1.2		
6700 00522135	-135	3	3.5-22.0	135	47-98	46	HDP-22	1.5		
6700 00522150	-150	3	3.5-22.0	150	47-103	46	HDP-22	1.7	FDC-07	S-0
6700 00607060	C6 -HDC07A -60	1	0.5-7.0	60	45	23	HDP-07A	0.9		
6700 00607075	-75	3	0.5-7.0	75	22-37	23	HDP-07A	1.0		
6700 00607105	-105	3	0.5-7.0	105	22-45	23	HDP-07A	1.1		
6700 00607135	-135	3	0.5-7.0	135	22-45	23	HDP-07A	1.2	FDC-09	S-1L
6700 00609060	-HDC09A -60	1	2.5-9.0	60	45	26	HDP-09	1.0		
6700 00609075	-75	3	2.5-9.0	75	27-37	26	HDP-09	1.0		
6700 00609105	-105	3	2.5-9.0	105	27-57	26	HDP-09	1.1		
6700 00609135	-135	3	2.5-9.0	135	27-57	26	HDP-09	1.2	FDC-12	S-3L
6700 00612060	-HDC12A -60	1	2.5-12.0	60	45	32	HDP-12	1.0		
6700 00612075	-75	1	2.5-12.0	75	60	32	HDP-12	1.1		
6700 00612105	-105	3	2.5-12.0	105	33-64	32	HDP-12	1.2		
6700 00612135	-135	3	2.5-12.0	135	33-69	32	HDP-12	1.4	FDC-16	S-4L
6700 00616060	-HDC16A -60	1	3.5-16.0	60	41	36	HDP-16	1.0		
6700 00616075	-75	1	3.5-16.0	75	56	36	HDP-16	1.1		
6700 00616105	-105	3	3.5-16.0	105	38-65	36	HDP-16	1.3		
6700 00616135	-135	3	3.5-16.0	135	38-82	36	HDP-16	1.5	FDC-22	S-5L
6700 00616150	-150	3	3.5-16.0	150	38-82	36	HDP-16	1.6		
6700 00622075	-HDC22A -75	2	3.5-22.0	75	56	46	HDP-22	1.3		
6700 00622105	-105	3	3.5-22.0	105	47-68	46	HDP-22	1.6		
6700 00622135	-135	3	3.5-22.0	135	47-98	46	HDP-22	1.9	FDC-22	S-5L
6700 00622150	-150	3	3.5-22.0	150	47-103	46	HDP-22	2.0		

1. La boquilla y la llave inglesa se venden por separado.
 2. *1 No es compatible con el cambio automático de herramienta (ATC).
 3. *2 Sólo para usarse con la abrazadera segmentada. No es compatible con los sistemas de sujeción por pernos de tracción.
1. Collet, spanner are sold separately.
 2. *1 Not compatible with automatic tool change (ATC).
 3. *2 For use with segment clamp only. Not compatible with draw-bolt clamping systems.

Ejemplo para Ordenar - Ordering Example

C3 - HDC07A - 35

Interfaz y diámetro de husillo

Shank size

Máx. Diámetro Interno de boquilla

Max. collet I.D.

Longitud de proyección

Projection length



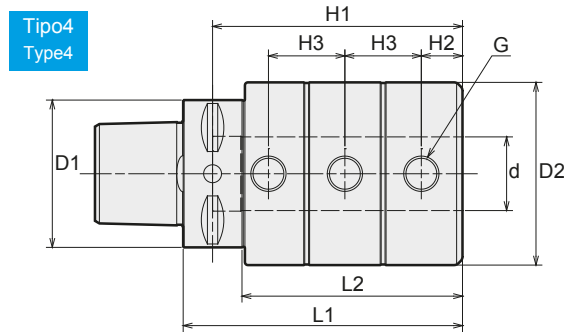
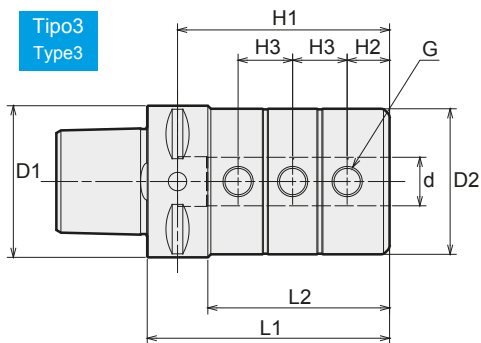
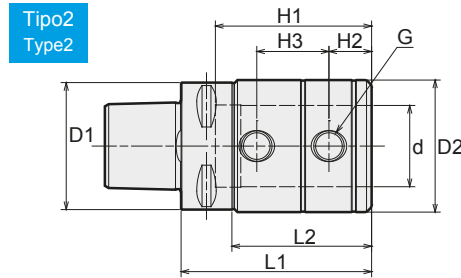
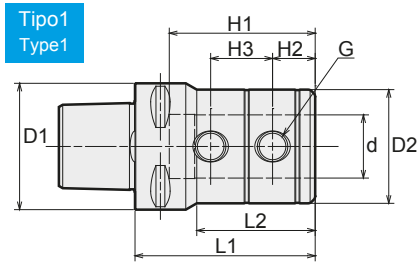

Código Code	Modelo Model	Tipo Type	d	L1	(L2)	D1	D2	H1	H2	H3	G	kg
6710 00308035	C3 -TSB8 - 35	2	8	35	20	32	36	20	5	10	6	0.3
6710 00310035	-TSB10 - 35	2	10	35	20	32	36	20	5	10	6	0.3
6710 00312040	-TSB12 - 40	2	12	40	25	32	36	24	6	12	6	0.3
6710 00408040	C4 -TSB8 - 40	1	8	40	18.8	40	36	20	5	10	6	0.5
6710 00410040	-TSB10 - 40	1	10	40	18.8	40	36	20	5	10	6	0.5
6710 00412045	-TSB12 - 45	1	12	45	23.8	40	36	24	6	12	6	0.5
6710 00416050	-TSB16 - 50	1	16	50	28.8	40	36	32	8	16	8	0.5
6710 00508060	C5 -TSB8 - 60	1	8	60	40	50	28	40	9	20	8	0.7
6710 00510065	-TSB10 - 65	1	10	65	45	50	35	45	9	22	8	0.8
6710 00512070	-TSB12 - 70	1	12	70	50	50	42	50	9	22	8	1.0
6710 00516080	-TSB16 - 80	3	16	80	60	50	48	70	14	18	10	1.2
6710 00520080	-TSB20 - 80	4	20	80	60	50	52	70	14	18	10	1.3
6710 00525095	-TSB25 - 95	4	25	95	75	50	62	85	14	26	12	1.9
6710 00608065	C6 -TSB8 - 65	11	8	65	43	63	28	40	9	20	8	1.0
6710 00610070	-TSB10 - 70	1	10	70	48	63	35	45	9	22	8	1.2
6710 00612075	-TSB12 - 75	1	12	75	53	63	42	50	9	22	8	1.4
6710 00616085	-TSB16 - 85	3	16	85	63	63	48	65	14	18	10	1.6
6710 00620085	-TSB20 - 85	3	20	85	63	63	52	70	14	18	10	1.7
6710 00625100	-TSB25 - 100	3	25	100	78	63	62	85	14	26	12	2.3
6710 00632115	-TSB32 - 115	3	32	115	93	63	62	100	14	30	12	2.4
6710 00640130	-TSB40 - 130	4	40	130	108	63	68	115	16	36	16	2.8

Ejemplo para Ordenar - Ordering Example

C3 - **TSB 8** - **35**

Interfaz y diámetro de husillo
Shank size

Diámetro Interno
I.D. (d)

Longitud de proyección
Projection length

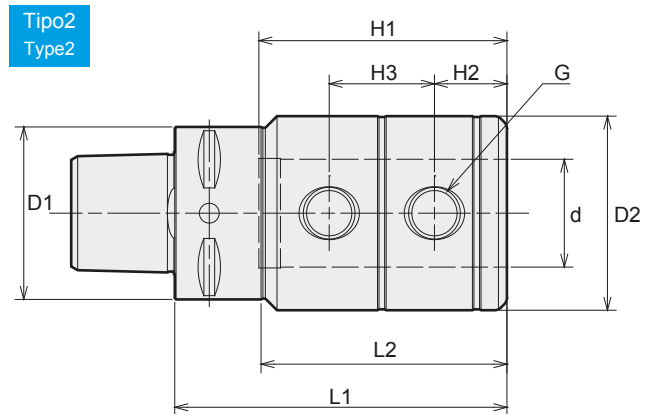
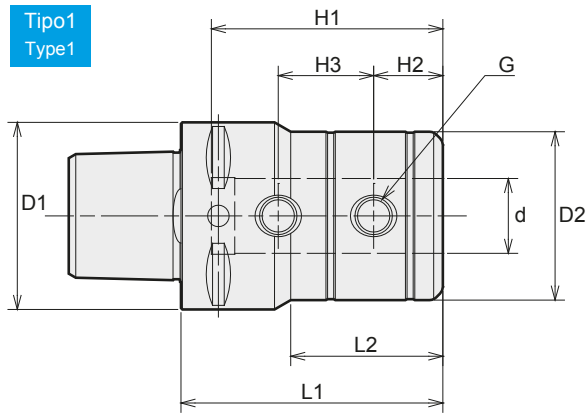

Código Code	Modelo Model	Tipo Type	d	L1	(L2)	D1	D2	H1	H2	H3	G	kg
6710 01316056	C3 -TSD16 -56	2	16	56	41	32	36	49.5	14.8	20.4	8	0.4
6710 01320060	-TSD20 -60	2	20	60	45	32	40	51.5	14.8	22.4	8	0.5
6710 01416056	C4 -TSD16 -56	1	16	56	32.5	40	36	49.5	14.8	20.4	8	0.5
6710 01420060	-TSD20 -60	1	20	60	60	40	40	51.5	14.8	22.4	8	0.6
6710 01425077	-TSD25 -77	2	25	77	57	40	45	57.5	16.8	24.4	12	0.8
6710 01516060	C5 -TSD16 -60	1	16	60	40	50	36	49	14	18	10	0.7
6710 01520060	-TSD20 -60	1	20	60	40	50	40	51	14	18	10	0.8
6710 01525070	-TSD25 -70	1	25	70	50	50	45	57	14	26	12	0.9
6710 01532075	-TSD32 -75	2	32	75	55	50	52	61	14	30	12	1.0
6710 01616070	C6 -TSD16 -70	1	16	70	48	63	36	49	14	18	10	1.1
6710 01620070	-TSD20 -70	1	20	70	48	63	40	51	14	18	10	1.2
6710 01625070	-TSD25 -70	1	25	70	48	63	45	57	14	26	12	1.2
6710 01632075	-TSD32 -75	1	32	75	53	63	52	61	14	30	12	1.3
6710 01640085	-TSD40 -85	2	40	85	63	63	65	71	16	36	16	1.8
6710 01642085	-TSD42 -85	2	42	85	63	63	67	71	16	36	16	1.8

Ejemplo para Ordenar - Ordering Example

C3	- TSD 16	- 56
Interfaz y diámetro de husillo Shank size	Diámetro Interno I.D. (d)	Longitud de proyección Projection length

CT·SA

Super tite-lock Milling Chuck

- Milling Chuck delgado. Sus ranuras tienen un diseño especial para permitir desbastes pesados.
- Slim design milling chuck. Specially designed slits enables heavy endmilling.

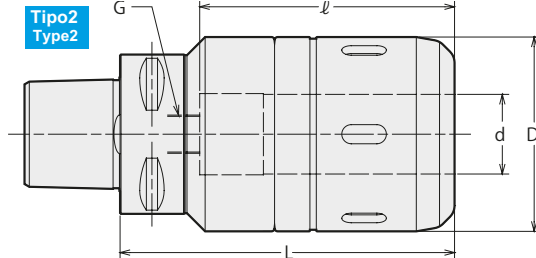
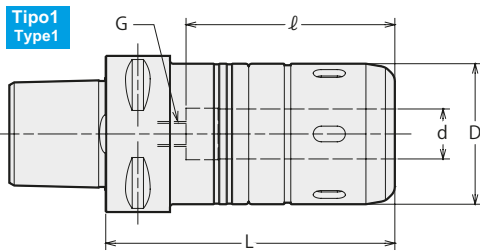

Precaución / Caution

Después de remover una herramienta de corte; girar el anillo de sujeción en sentido contrario a las manecillas del reloj por más de 360 grados.

Please rotate the clamping ring counterclockwise more than 360 degrees after a cutting tool is removed.

Código Code	Modelo Model	Tipo Type	d	D	L	ℓ	G	Llave Inglesa Spanner
6760 00516070	C5 -CT16SA - 70	*3	16	45	70	63	—	HS-1-16
6760 00516090	- 90	1	16	45	90	65	10	
6760 00520075	-CT20SA - 75	*1	20	52	75	65	—	HS-2-20
6760 00520090	- 90	*3	20	52	90	80	—	
6760 00525090	-CT25SA - 90	*3	25	61	90	80	—	HS-2.5-25
6760 00525105	-105	*4	25	61	105	80	12	
6760 00532090	-CT32SA - 90	*2	32	73	90	75	—	HS-3-32
6760 00616070	C6 -CT16SA - 70	*3	16	45	70	61	—	
6760 00616090	- 90	1	16	45	90	65	10	HS-1-16
6760 00616105	-105	1	16	45	105	65	10	
6760 00616135	-135	1	16	45	135	65	10	
6760 00620075	-CT20SA - 75	*1	20	52	75	60	—	HS-2-20
6760 00620090	- 90	*3	20	52	90	75	—	
6760 00620105	-105	*4	20	52	105	80	12	
6760 00620135	-135	1	20	52	135	80	12	
6760 00625080	-CT25SA - 80	*1	25	61	80	65	—	HS-2.5-25
6760 00625090	- 90	*3	25	61	90	75	—	
6760 00625105	-105	*4	25	61	105	80	12	
6760 00625135	-135	1	25	61	135	80	12	
6760 00632090	-CT32SA - 90	*2	32	73	90	75	—	
6760 00632105	-105	*2	32	73	105	90	—	HS-3-32
6760 00632135	-135	*4	32	73	135	100	18	

1. Al hacer su orden, indique el número de llaves inglesas que requiere. Las llaves inglesas "son gratuitas" y están limitadas al número de portaherramientas de fresado de su orden.

2. La tolerancia del zanco de las herramientas de corte deben estar dentro de h7.

1. When ordering, indicate number of spanners required. "No charge" spanners are limited to number of milling chucks on order.

2. Tolerance of cutting tool shank must be h7.

Accesorios Accessories

Los modelos con * 1- * 4 no pueden usarse con algunos accesorios debido a la corta ℓ longitud.

Para mayor información, consulta las págs. 062-065 del NTTOOL CATALOG No.1

Models with * 1 - * 4 cannot be used with some accessories due to short ℓ length.

For more information, please refer to Pg. 062-065 of the NTTOOL CATALOG No.1

	Tornillo de retención Stopper Bolt	Boquilla recta Straight Collet	Adaptador Morse Morse Taper Adapter		Adaptador Jacobs Jacobs Adapter		
	BL pág. 72	MC pág 70	MCA pág 71	MA pág 72	MAB pág 72	JA pág 73	JAB pág 73
* 1	X	○	X	X	X	X	X
* 2	X	○	X	X	○	X	○
* 3	X	○	X	○	○	○	○
* 4	○	○	X	○	○	○	○

Longitud Mínima de Inserción Min. chucking length

Sin boquilla MC
Without MC collet

Con boquilla MC
With MC collet

D.I. del portaherramienta de fresado I.D. of Milling Chuck	Longitud mín de inserción Min. chucking length
16, 20	40
25, 32	50

D.I. de la boquilla Collet I.D.	Longitud mín de inserción Min. chucking length	
	MC	MC-C, MC-OH
6, 8	30	30
10, 12	40	40
16, 20	45	45
25	50	50

Ejemplo para Ordenar - Ordering Example

C5 - CT 16 SA - 70

Interfaz y diámetro de husillo I.D. Longitud de proyección
Shank size I.D. Projection length

HDZ

"R" Zero Holder

- La precisión del borde de la herramienta de corte se puede ajustar hasta casi cero.
- Runout accuracy of the cutting edge can be adjusted as closely as to zero.

Tipo1 Type1

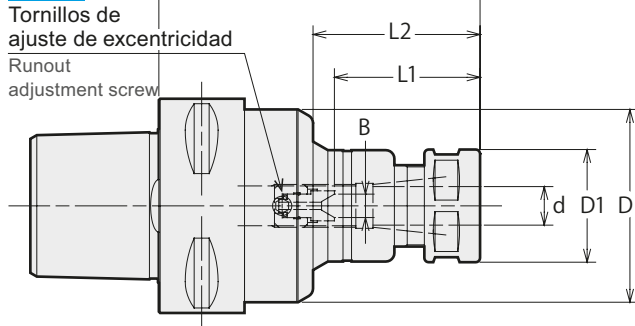

Tipo2 Type2

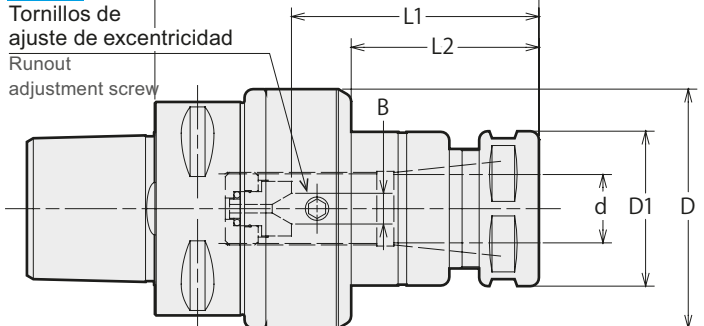

Código Code	Modelo Model	Tipo Type	d	L	L1	L2	B	D	D1	Tuerca ciega Nut	Boquilla Collet	Llave Inglesa Spanner	Llave Allen Wrench
6750 00507090	C5 -HDZ07 - 90	1	0.5 - 7.0	90	22 ~ 45	39	0 ~ 4	41	23	HDP-07A	FDC-07	S-0	L-3T
6750 00507120	-120	1	0.5 - 7.0	120	22 ~ 45	84	0 ~ 4	41	23	HDP-07A	FDC-07	S-0	L-3T
6750 00509090	-HDZ09 - 90	1	2.5 - 9.0	90	27 ~ 52	39	0 ~ 4	45	26	HDP-09	FDC-09	S-1L	L-3T
6750 00509120	-120	1	2.5 - 9.0	120	27 ~ 57	84	0 ~ 4	45	26	HDP-09	FDC-09	S-1L	L-3T
6750 00512090	-HDZ12 - 90	2	2.5 - 12.0	90	33 ~ 49	44	0 ~ 5	52	32	HDP-12	FDC-12	S-3L	L-4T
6750 00512135	-135	2	2.5 - 12.0	135	33 ~ 69	89	0 ~ 5	52	32	HDP-12	FDC-12	S-3L	L-4T
6750 00516090	-HDZ16 - 90	2	3.5 - 16.0	90	38 ~ 58	44	0 ~ 6	56	36	HDP-16	FDC-16	S-4L	L-4T
6750 00516135	-135	2	3.5 - 16.0	135	38 ~ 82	89	0 ~ 6	56	36	HDP-16	FDC-16	S-4L	L-4T
6750 00607090	C6 -HDZ07 - 90	1	0.5 - 7.0	90	22 ~ 45	37	0 ~ 4	41	23	HDP-07A	FDC-07	S-0	L-3T
6750 00607120	-120	1	0.5 - 7.0	120	22 ~ 45	82	0 ~ 4	41	23	HDP-07A	FDC-07	S-0	L-3T
6750 00609090	-HDZ09 - 90	1	2.5 - 9.0	90	27 ~ 52	37	0 ~ 4	45	26	HDP-09	FDC-09	S-1L	L-3T
6750 00609120	-120	1	2.5 - 9.0	120	27 ~ 57	82	0 ~ 4	45	26	HDP-09	FDC-09	S-1L	L-3T
6750 00612090	-HDZ12 - 90	1	2.5 - 12.0	90	33 ~ 49	48	0 ~ 5	56	32	HDP-12	FDC-12	S-3L	L-4T
6750 00612135	-135	1	2.5 - 12.0	135	33 ~ 69	93	0 ~ 5	56	32	HDP-12	FDC-12	S-3L	L-4T
6750 00616090	-HDZ16 - 90	1	3.5 - 16.0	90	38 ~ 50	48	0 ~ 6	62	36	HDP-16	FDC-16	S-4L	L-4T
6750 00616135	-135	1	3.5 - 16.0	135	38 ~ 82	93	0 ~ 6	62	36	HDP-16	FDC-16	S-4L	L-4T
6750 00622105	-HDZ22A -105	2	3.5 - 22.0	105	47 ~ 68	53	0 ~ 8	69	46	HDP-22	FDC-22	S-5L	L-6T
6750 00622150	-150	2	3.5 - 22.0	150	47 ~ 103	98	0 ~ 8	69	46	HDP-22	FDC-22	S-5L	L-6T

1. La boquilla, llave inglesa, tornillo Allen opresor de preajuste y el tornillo de preajuste para procesos semisecos se venden por separado. El tornillo estándar de preajuste está incluido.
 2. Consulte la pág 091 del NT TOOL CATALOG No.2 para conocer la longitud mínima para insertar herramientas en caso de usar nuestras boquillas refrigerantes (OH, C o MS).
 3. "L1" indica la dimensión al usar el tornillo de preajuste.
 4. Consulte la pág. 520 del NTTOOL CATALOG No.2 para conocer el Torque recomendado para nuestros productos.
1. Collet, spanner, hexagon head preset screw, preset screw for semi-dry processing, and adjustment wrench are sold separately. Standard preset screw is included.
 2. Refer to P. 083 of the NTTOOL CATALOG No.1 for minimum tool insertion length in case of using our coolant collets (OH,C or MS).
 3. "L1" indicates dimension when using with a preset screw.
 4. See P. 485 of the NTTOOL CATALOG No.1 for standard tightening torque.

Ejemplo para Ordenar - Ordering Example

C5 - HDZ12 - 90

Interfaz y diámetro de husillo

Máx. Diámetro Interno de boquilla

Longitud de proyección

Shank size

Max. collet I.D.

Projection length

Para mayor información consulte el NT TOOL CATALOG No.1
For more information, please refer to the NTTOOL CATALOG No.1

Boquilla Collet	Llave Inglesa Spanner	Llave Allen Adjustment wrench	Tornillo de preajuste Preset screw
Pág. 090	Pág. 099	Pág. 099	Pág. 098

PHC-A

Power Hydro Chuck

- Portaherramienta Hidráulico con compatibilidad para el uso de boquillas. Adecuado para cortes de alta precisión.
- Hydro chuck with collet holder flexibility. Suitable for high precision cutting.

Tipo1
Type1

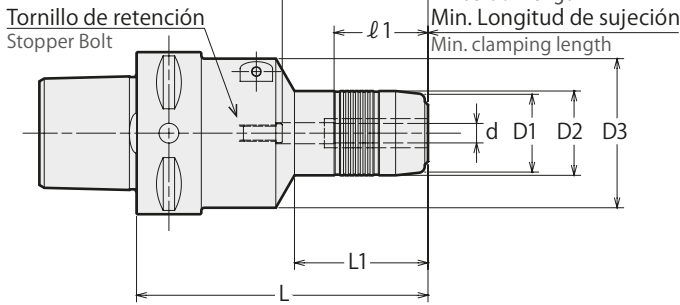

Tipo2
Type2

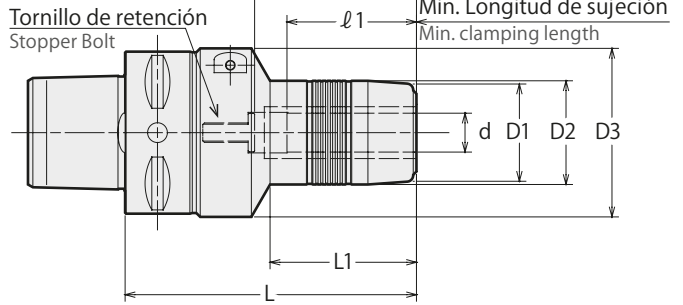

Tipo3
Type3

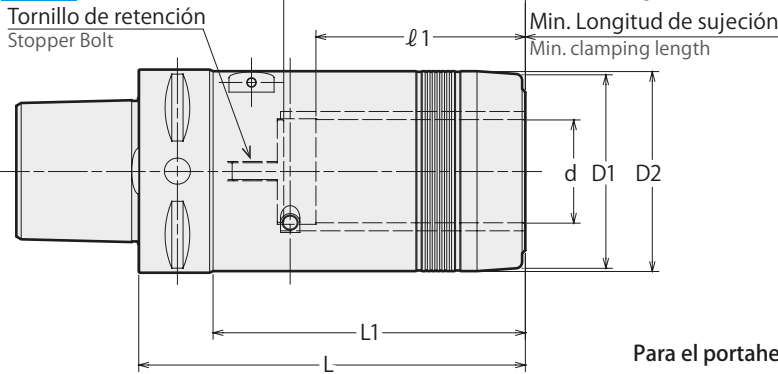

Para el portaherramienta con ※ 1, el tornillo de retención no está incluido.
For the chuck with ※ 1, the stopper bolt is not included.

Código Code	Modelo Model	Tipo Type	d	L	L1	D1	D2	D3	ℓ	ℓ1	Llave Allen Wrench
6720 00503055	C5 -PHC03A -55	※1 1	3	55	4	—	24	46	42	18	L-4T
6720 00503090	-90	※1 1	3	90	44	—	25	46	49	18	
6720 00504055	-PHC04A -55	※1 1	4	55	9	—	25	46	42	24	
6720 00504090	-90	※1 1	4	90	45	—	25	46	49	24	
6720 00506055	-PHC06A -55	1 1	6	55	11	24	26	46	34	29	
6720 00506090	-90	1 1	6	90	41	24	26	46	45	29	
6720 00507055	-PHC07A -55	1 1	7	55	11	26	28	46	34	29	
6720 00507090	-90	1 1	7	90	41	26	28	46	45	29	
6720 00508055	-PHC08A -55	1 1	8	55	11	26	28	46	34	29	
6720 00508090	-90	1 1	8	90	41	26	28	46	45	29	
6720 00509060	-PHC09A -60	※1 1	9	60	19	28	30	46	47	33	
6720 00509090	-90	1 1	9	90	44	28	30	46	50	40	
6720 00510060	-PHC10A -60	※1 1	10	60	19	28	30	46	47	33	
6720 00510090	-90	2 10	10	90	44	28	30	52	50	40	
6720 00511060	-PHC11A -60	※1 1	11	60	17	30	32	46	47	33	
6720 00511090	-90	2 11	11	90	45	30	32	52	50	40	
6720 00512060	-PHC12A -60	※1 1	12	60	17	30	32	46	47	33	
6720 00512090	-90	2 12	12	90	45	30	32	52	50	40	
6720 00513075	-PHC13A -75	1 13	13	75	17	34	36	46	50	33	
6720 00513090	-90	2 13	13	90	46	34	36	52	50	40	
6720 00514075	-PHC14A -75	1 14	14	75	17	34	36	46	50	33	
6720 00514090	-90	2 14	14	90	46	34	36	52	50	40	
6720 00515075	-PHC15A -75	1 15	15	75	18	36	38	46	50	33	
6720 00515090	-90	2 15	15	90	46	36	38	52	50	40	
6720 00516075	-PHC16A -75	1 16	16	75	18	36	38	46	50	33	
6720 00516090	-90	2 16	16	90	46	36	38	52	50	40	
6720 00520090	-PHC20A -90	1 20	20	90	49	40	42	46	50	40	
6720 00520125	-125	1 20	20	125	69	40	42	46	70	40	
6720 00525105	-PHC25A -105	2 25	25	105	59	50	52	62	60	50	L-6T

L-4T

L-6T

Código Code	Modelo Model	Tipo Type	d	L	L1	D1	D2	D3	ℓ	ℓ1	Llave Allen Wrench	
6720 00603050	C6 -PHC03A -50	※1	1	3	50	4	—	24	46	35	18	L-4T
6720 00603090	-90	※1	1	3	90	44	—	25	46	49	18	
6720 00604055	-PHC04A -55	※1	1	4	55	9	—	25	46	40	24	
6720 00604090	-90	※1	1	4	90	45	—	25	46	49	24	
6720 00606060	-PHC06A -60		1	6	60	11	24	26	46	34	29	
6720 00606090	-90		1	6	90	41	24	26	46	45	29	
6720 00606120	-120		1	6	120	41	24	26	46	45	29	
6720 00607060	-PHC07A -60		1	7	60	11	26	28	46	34	29	
6720 00607090	-90		1	7	90	41	26	28	46	45	29	
6720 00608060	-PHC08A -60		1	8	60	11	26	28	46	34	29	
6720 00608090	-90		1	8	90	41	26	28	46	45	29	
6720 00608120	-120		1	8	120	41	26	28	46	45	29	
6720 00609065	-PHC09A -65	※1	1	9	65	19	28	30	46	47	33	
6720 00609090	-90		1	9	90	44	28	30	46	50	40	
6720 00610065	-PHC10A -65	※1	1	10	65	19	28	30	46	47	33	
6720 00610090	-90		1	10	90	44	28	30	52	50	40	
6720 00610120	-120		1	10	120	64	28	30	52	70	40	
6720 00611065	-PHC11A -65	※1	1	11	65	17	30	32	46	47	33	
6720 00611090	-90		1	11	90	45	30	32	52	50	40	
6720 00612065	-PHC12A -65	※1	1	12	65	17	30	32	46	47	33	
6720 00612090	-90		1	12	90	45	30	32	52	50	40	
6720 00612120	-120		1	12	120	65	30	32	52	70	40	
6720 00613075	-PHC13A -75		1	13	75	17	34	36	46	45	33	
6720 00613090	-90		1	13	90	46	34	36	52	50	40	
6720 00614075	-PHC14A -75		1	14	75	17	34	36	46	45	33	
6720 00614090	-90		1	14	90	46	34	36	52	50	40	
6720 00614120	-120		1	14	120	66	34	36	52	70	40	
6720 00615075	-PHC15A -75		1	15	75	18	36	38	46	45	33	
6720 00615090	-90		1	15	90	46	36	38	52	50	40	
6720 00616075	-PHC16A -75		1	16	75	18	36	38	46	45	33	
6720 00616090	-90		1	16	90	46	36	38	52	50	40	
6720 00616120	-120		1	16	120	66	36	38	52	70	40	
6720 00620090	-PHC20A -90		1	20	90	49	40	42	46	50	40	
6720 00620120	-120		1	20	120	69	40	42	46	70	40	
6720 00625105	-PHC25A -105		1	25	105	59	50	52	62	60	50	L-6T
6720 00625120	-120		1	25	120	59	50	52	62	80	50	
6720 00632120	-PHC32A -120		3	32	120	96	60	62	-	75	65	

- El zanco de la herramienta de corte debe estar dentro de las tolerancias especificadas a continuación;
 - Diámetro del zanco menor a 6 mm: dentro de la tolerancia h6.
 - Diámetro del zanco mayor a 6 mm: dentro de la tolerancia h7.
 - h6 o 0/-0.01 es la tolerancia recomendada en las herramientas de corte al usar nuestros productos.
- PHC12A y PHC20A cuentan con orificios de acople, para las boquillas que tienen incluida la clavija de tope.

- Cutting tool shank must be within tolerances specified below ;
 - Shank diameter less than 6mm : Within h6 tolerance
 - Shank diameter 6mm and over : Within h7 tolerance
 - h6 or 0/-0.01 tolerance is recommended when newly making a cutting tool.
- PHC12A and PHC20A have pin holes for collet with stopper pin on its body.

Ejemplo para Ordenar - Ordering Example

C6 - PHC 12 A - 120

Interfaz y diámetro
de husillo
Shank size

I.D.
I.D.

Longitud de
proyección
Projection length

Para mayor información consulte el "CATALOG No.27" de NT TOOL.
For more information, please refer to the NTTOOL CATALOG No.27.

Boquilla PHS
PHS Collet
Pág.114

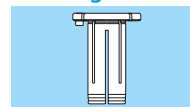

Llave Allen
Hex. Wrench
Pág. 099



BT

CAT

AHO

HSK-A/E/F/C

HSK-T

C

UTS

Máquinas
Especializadas
Specialized
Machine

Equipo
Relacionado
Related
Equipment

Taladro de
Biselado & de
Casquillo
Bush &
Chamfering
Drill

Collet Holder

Side Lock Holder

Milling Chuck

"R" Zero Holder

Hydraulic Chuck

Tapping Chuck

Shrink Fit

Arbors

Turning Tool

Synchronous Tap Holder With Easy Tool Length Adjustment

- La longitud de proyección de la herramienta de corte se puede ajustar simplemente girando el anillo ubicado en la circunferencia del portaherramienta.
- Projection length of the cutting tool can be adjusted by simply turning circumference of the holder.

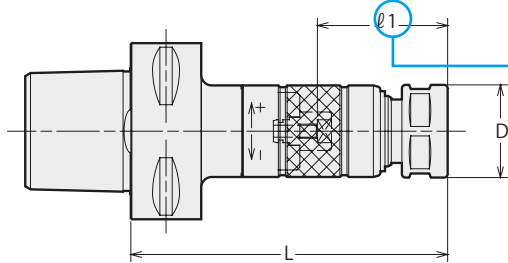

Consulte la pág.399



Las medidas del machuelo se basan en un estándar JIS antiguo.

Tap sizes are based on old JIS standard.

(NOTA) El D.E. de la tuerca del STM8 es de 19 mm.

(NOTE) Nut O.D. of STM8 is 19mm.

Código Code	Modelo Model	Medida de machuelo Tap Size	L	D	Tuerca ciega Nut	Boquilla Collet	Unidad de preajuste Preset driver	Llave Inglesa Spanner
6730 00508090	C5 -STM8 -90	(Old JIS Taps) M4~8 U No8~5/16 (OSG Synchro Taps) M4~6	90	21	KDP-1414	FDC-07	STS-8	φ17mm
6730 00508135	- 135		135	21	KDP-1414			
6730 00512090	-STM12 -90	(Old JIS Taps) M4~12 U No8~7/16 PT1/8 (OSG Synchro Taps) M4~10	90	26	HTP-09	FSC-09	STS-12	S-1L
6730 00512135	- 135		135	26	HTP-09			
6730 00518105	-STM18 -105	(Old JIS Taps) M14~18 U1/2~3/4 PT1/4~3/8 (OSG Synchro Taps) M12~14	105	36	HTP-16	FSC-16	STS-18	S-4L
6730 00518150	- 150		150	36	HTP-16			
6730 00530105	-STM30 -105	(Old JIS Taps) M20~30 U7/8~1-1/8 PT1/2~3/4 (OSG Synchro Taps) M16~27	105	46	HTP-22	FSC-22	STS-30	S-5L
6730 00530150	- 150		150	46	HTP-22			
6730 00608090	C6 -STM8 -90	(Old JIS Taps) M4~8 U No8~5/16 (OSG Synchro Taps) M4~6	90	21	KDP-1414	FDC-07	STS-8	φ17mm
6730 00608135	- 135		135	21	KDP-1414			
6730 00612090	-STM12 -90	(Old JIS Taps) M4~12 U No8~7/16 PT1/8 (OSG Synchro Taps) M4~10	90	26	HTP-09	FSC-09	STS-12	S-1L
6730 00612135	- 135		135	26	HTP-09			
6730 00618105	-STM18 -105	(Old JIS Taps) M14~18 U1/2~3/4 PT1/4~3/8 (OSG Synchro Taps) M12~14	105	36	HTP-16	FSC-16	STS-18	S-4L
6730 00618150	- 150		150	36	HTP-16			
6730 00630105	-STM30 -105	(Old JIS Taps) M20~30 U7/8~1-1/8 PT1/2~3/4 (OSG Synchro Taps) M16~27	105	46	HTP-22	FSC-22	STS-30	S-5L
6730 00630150	- 150		150	46	HTP-22			

1. La boquilla, la llave inglesa y la unidad de preajuste se venden por separado.
2. Favor de ver a continuación para conocer la dimensión $\ell 1$. Para modelos con * , consultar la fila de $\ell 1$ (*) en la tabla que aparece a continuación.
3. El STM8 puede hacer orificios de machueleado menores a M4. Las boquillas a usar son como se especifica a continuación.
M1.M2.6: FDC-03007- ※※ M3-M3.5: FDC-04007- ※※
La unidad de preajuste no se usará para los usos antes mencionados..

Ejemplo para Ordenar - Ordering Example

C5 - STM12 - 90

Interfaz y diámetro de husillo
Shank size

Medida de portaherramienta
Holder size

Longitud de proyección
Projection length

1. Collet, spanner and preset driver are sold separately.
2. Please see below for $\ell 1$ dimension. For models with * , please see $\ell 1$ (*) row in the below chart.
3. Tap holes smaller than M4 can be made by STM8. Collets to be used are as follows.
M1-M2.6: FDC-03007- ※※ M3-M3.5: FDC-04007- ※※
Tap drive will not be used for the above usages.

Machuelos JIS antiguas
Old JIS Taps

Sin función para refrigerante por vena de lubricación. Without center-through coolant			Con función para refrigerante por vena de lubricación. With center-through coolant (STM12~30)		
Medida de machuelo - Tap Size	$\ell 1$	$\ell 1(*)$	Medida de machuelo - Tap Size	$\ell 1$	$\ell 1(*)$
M4~6 U No.8~1/4	21~35	21~26	M4~6 U No.8~1/4	24~35	24~26
M7~12 U 5/16~U7/16 PT1/8	23~37	23~28	M7~10 U 5/16~3/8	25~37	25~28
M13~15 U 1/2~5/8 PT1/4	28~42	-	M11~12 U 7/16 PT 1/8	26~37	26~28
M16~17	32~45	-	U1/2	32~42	-
M18~27 U 3/4~U1 PT3/8~5/8	33~47	-	M13~15 U9/16	33~42	-
M30 U1-1/8 PT3/4	38~52	-	U5/8 PT1/4	34~42	-
Con función para refrigerante por vena de lubricación. With center-through coolant (STM8)			M16	35~46	-
Medida de machuelo - Tap Size	$\ell 1$	$\ell 1(*)$	M18 U 3/4 PT3/8	36~47	-
M4~6 U No.8~1/4	25~35	25~26	M20~21 PT1/2	40~47	-
M7~8 U5/16	26~37	26~28	M22 U 7/8	41~47	-
			M23	42~47	-
			M24~25 PT5/8	43~47	-
			M26~27 U1	44~47	-
			M28	45~52	-
			M30 PT3/4	46~52	-
			U 1-1/8	48~52	-

Machuelos sincronizados OSG
OSG Synchro Taps

Sin función para refrigerante por vena de lubricación. Without center-through coolant			Con función para refrigerante por vena de lubricación. With center-through coolant (STM8)		
Medida de machuelo - Tap Size	$\ell 1$	$\ell 1(*)$	Medida de machuelo - Tap Size	$\ell 1$	$\ell 1(*)$
M4~6	21~35	21~26	M4~6	25~35	25~26
M8~10	23~37	23~28			
M12~14	28~42	-			
M16~27	33~47	-			
Con función para refrigerante por vena de lubricación. With center-through coolant (STM12~30)			Medida de machuelo - Tap Size	$\ell 1$	$\ell 1(*)$
			M4~6	24~35	24~26
			M8~10	26~37	26~28
			M12	33~42	-
			M14	34~42	-
			M16~20	40~46	-
			M22~27	44~47	-

YAMAWA X Series

Sin función para refrigerante por vena de lubricación. Without center-through coolant			Con función para refrigerante por vena de lubricación. With center-through coolant (STM8)		
Medida de machuelo - Tap Size	$\ell 1$	$\ell 1(*)$	Medida de machuelo - Tap Size	$\ell 1$	$\ell 1(*)$
M6 M8	23~37	23~28	M6	26~37	26~28
M10 M12	28~42	-			
Con función para refrigerante por vena de lubricación. With center-through coolant (STM12~30)			Medida de machuelo - Tap Size	$\ell 1$	$\ell 1(*)$
			M6	25~37	25~28
			M8	26~37	26~28
			M10	33~42	-
			M12	34~42	-

Para mayor información consulte el NT TOOL CATALOG No.2
For more information, please refer to the NT TOOL CATALOG No.2

Boquilla - Collet

FDC Pág. 342
FSC Pág. 343



Unidad Preajustada Preset driver

Pág. 342



Llave Inglesa Spanner

Pág. 99



BT

CAT

AHO

HSK-A/E/F/C

HSK-T

C

UTS

Máquinas Especializadas

Specialized Machine

Equipo Relacionado

Related Equipment

Taladro de Biselado & de Casquillo

Bush & Chamfering Drill

Collet Holder

Side Lock Holder

Milling Chuck

"R" Zero Holder

Hydraulic Chuck

Tapping Chuck

Shrink Fit

Arbors

Turning Tool

SRD

Shrink Fit (Estándar DIN / DIN Standard)

- El método de contracción sujeta firmemente a una herramienta de corte al calentar y enfriar el portaherramienta. Alta precisión y fuerza de sujeción. (Para DIN)
- Shrinkage method sets a cutting tool firmly by heating and cooling the chuck. High precision, rigidity and strong chucking. (DIN Type)

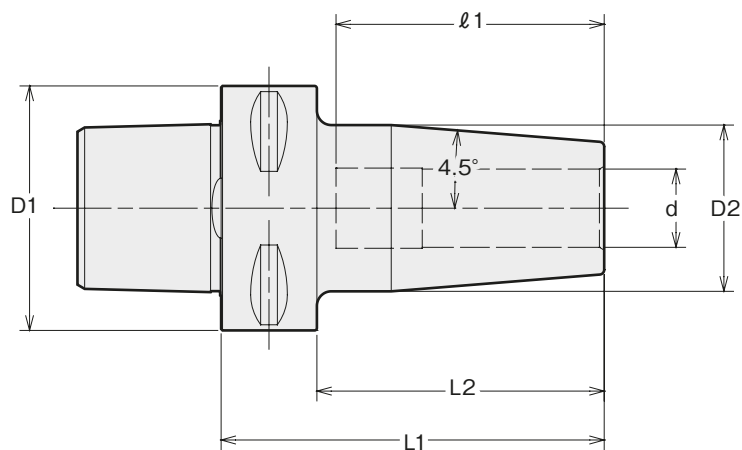

Código Code	Modelo Model	d	D1	D2	L1	L2	ℓ1
6770 00506075	C5 -SRD6A - 75	6	50	27	75	55	36
6770 00508075	-SRD8A - 75	8	50	27	75	55	50
6770 00510075	-SRD10A - 75	10	50	31	75	55	50
6770 00512075	-SRD12A - 75	12	50	31	75	55	50
6770 00514080	-SRD14A - 80	14	50	34	80	60	55
6770 00516080	-SRD16A - 80	16	50	34	80	60	55
6770 00518080	-SRD18A - 80	18	50	41	80	60	55
6770 00520085	-SRD20A - 85	20	50	42	85	65	55
6770 00606080	C6 -SRD6A - 80	6	63	27	80	58	36
6770 00608080	-SRD8A - 80	8	63	27	80	58	50
6770 00610080	-SRD10A - 80	10	63	31	80	58	50
6770 00612080	-SRD12A - 80	12	63	32	80	58	50
6770 00614085	-SRD14A - 85	14	63	34	85	63	55
6770 00616085	-SRD16A - 85	16	63	34	85	63	55
6770 00618085	-SRD18A - 85	18	63	42	85	63	55
6770 00620085	-SRD20A - 85	20	63	42	85	63	55
6770 00625090	-SRD25A - 90	25	63	53	90	68	62
6770 00632095	-SRD32A - 95	32	63	53	95	73	62

Siempre use herramientas de zanco de carburo con tolerancia de h6.
Always use carbide shank tools with h6 tolerance.

Tabla de dispositivos térmicos
Heating device chart

Dispositivo térmico Heating device	Portaherramienta - Holder	
	SRD φ6~8	SRD φ10~32
ISG3430	○	○
SRK-HA1,HB2	×	○

Ejemplo para Ordenar - Ordering Example

C5 - SRD10A - 75

Interfaz y diámetro de husillo

I.D.

Longitud de proyección

Shank size

I.D.

Projection length

Face Mill Arbor

- Para fresa JIS B4113.
- For JIS B4113 face mill.

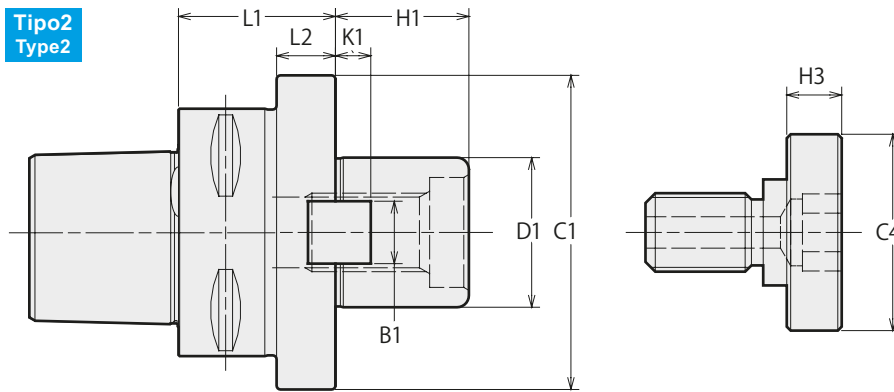
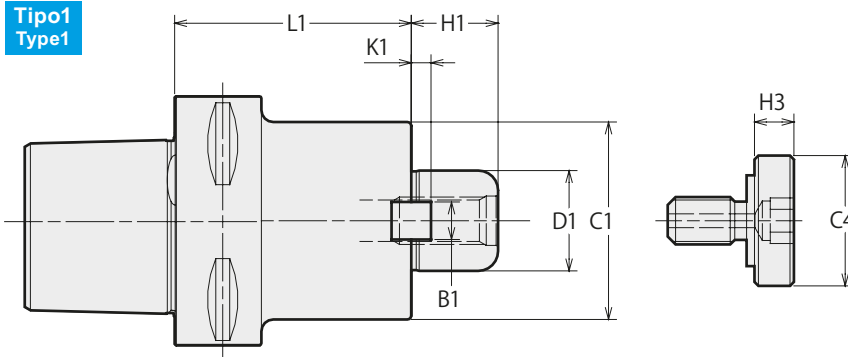

Código Code	Modelo Model	Tipo Type	D1	L1	L2	C1	H1	B1	K1	C4	H3	Perno de sujeción Clamp bolt	Ejemplo del diá. de cortador Cutter dia. example
6740 00525030	C5 -FMA25.4A - 30	1	25.4	30	—	50	22	9.5	5	33	10	MBA-M12	80
6740 00525060	- 60	1	25.4	60	—	50	22	9.5	5	33	10		
6740 00531045	-FMA31.75A - 45	2	31.75	45	24	60	30	12.7	7	40	10	MBAM16	100
6740 00531060	- 60	2	31.75	60	25	60	30	12.7	7	40	10		
6740 00625030	C6 -FMA25.4A - 30	1	25.4	30	—	50	22	9.5	5	33	10	MBA-M12	80
6740 00625060	- 60	1	25.4	60	—	50	22	9.5	5	33	10		
6740 00625090	- 90	1	25.4	90	—	50	22	9.5	5	33	10	MBA-M16	100
6740 00631030	-FMA31.75A - 30	1	31.75	30	—	60	30	12.7	7	40	10		
6740 00631060	- 60	1	31.75	60	—	60	30	12.7	7	40	10	MBA-M20	125
6740 00631090	- 90	1	31.75	90	—	60	30	12.7	7	40	10		
6740 00638040	-FMA38.1A - 40	2	38.1	40	15	80	34	15.9	9	50	14		

Incluye el perno de sujeción.
Clamp bolt is Included.

Ejemplo para Ordenar - Ordering Example

C5	- FMA25.4A	- 60
Interfaz y diámetro de husillo Shank size	D1	Longitud de proyección Projection length
	D1	

DCLN

- Doble sujeción / Para maquinados generales
- Double Clamp / For General Machining

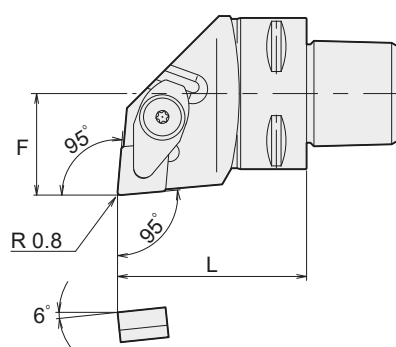
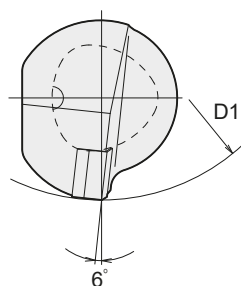
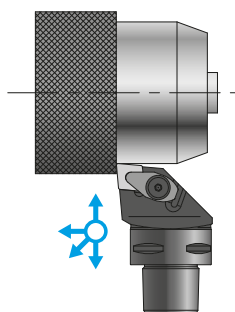

Se muestra el dibujo a la derecha.
Right-hand drawing shown.

Código Code	Modelo Model	F	L	D1	Kg	Inserto Insert	Accesorios (incluido) - Accessory (included)					
							Lamina Sheet	Lamina de la Clavija de Tope Sheet Stopper Pin	Puente de Sujeción Clamp Bridge	Resorte Spring	Tornillo de retención Clamp Screw	Llave Allen Wrench
6800 01311101	C3-DCLN R -22040 - 09	22	40	70		CNM	LLSCN3T3	LLP23	DCK2211	DCS2	DC0520T	TKY15F
6800 01311201	L -22040 - 09	22	40	70		CNG						
6800 01411101	C4-DCLN R -27050 - 12	27	50	110		CNM	LLSCN42	LLP14	DCK2613	DCS1	DC0621T	TKY20F
6800 01411201	L -27050 - 12	27	50	110		CNG						
6800 01511101	C5-DCLN R -35060 - 12	35	60	110		CNM	LLSCN42	LLP14	DCK2613	DCS1	DC0621T	TKY20F
6800 01511201	L -35060 - 12	35	60	110		CNG						
6800 01611101	C6-DCLN R -45065 - 12	45	65	110		CNM	LLSCN42	LLP14	DCK2613	DCS1	DC0621T	TKY20F
6800 01611201	L -45065 - 12	45	65	110		CNG						

- Los insertos no están incluidos. Utilice estándar ISO para los insertos.
- La dimensión D1 muestra los diámetros de corte más pequeños.

- Inserts are not included. Please use ISO Standard inserts.
- The D1 dimension shows the smallest cutting diameter.

Ejemplo para ordenar - Ordering Example

C4 - DCLN R - 27 050 - 12

Medida de zanco Shank size	Modelo Model	Posición Hand	F	L	Longitud de cara Face Length
			F	L	

DDJN

- Doble sujeción / Perfil de Maquinado • Para exterior
- Double Clamp / For Exterior • Profile Machining

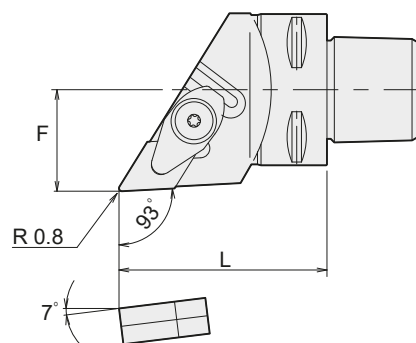
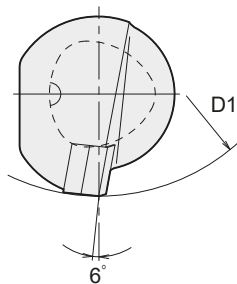
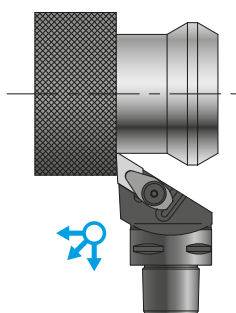

Se muestra el dibujo a la derecha.
Right-hand drawing shown.

Código Code	Modelo Model	F	L	D1	Kg	Inserto Insert	Accesorios (incluido) - Accessory (included)					
							Lamina Sheet	Lamina de la Clavija de Tope Sheet Stopper Pin	Puente de Sujeción Clamp Bridge	Resorte Spring	Tornillo de retención Clamp Screw	Llave Allen Wrench
6800 01322101	C3-DDJN R -22045 - 11	22	45	70		DNM	LLSDN32	LLP23	DCK2211	DCS2	DC0520T	TKY15F
6800 01322201	L -22045 - 11	22	45	70		DNG						
6800 01422101	C4-DDJN R -27055 - 15	27	55	110		DNM	LLSDN43	LLP24	DCK2613	DCS1	DC0621T	TKY20F
6800 01422201	L -27055 - 15	27	55	110		DNG						
6800 01522101	C5-DDJN R -35060 - 15	35	60	110		DNM	LLSDN43	LLP24	DCK2613	DCS1	DC0621T	TKY20F
6800 01522201	L -35060 - 15	35	60	110		DNG						
6800 01622101	C6-DDJN R -45065 - 15	45	65	110		DNM	LLSDN43	LLP24	DCK2613	DCS1	DC0621T	TKY20F
6800 01622201	L -45065 - 15	45	65	110		DNG						

- Los insertos no están incluidos. Utilice estándar ISO para los insertos.
- La dimensión D1 muestra los diámetros de corte más pequeños.

- Inserts are not included. Please use ISO Standard inserts.
- The D1 dimension shows the smallest cutting diameter.

Ejemplo para ordenar - Ordering Example

C4 - DDJN R - 27 055 - 15

Medida de zanco Shank size	Modelo Model	Posición Hand	F	L	Longitud de cara Face Length
			F	L	

DDUN

● Doble sujeción / Perfil de Maquinado • Para borde

● Double Clamp / For Edge • Profile Machining

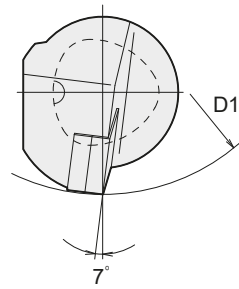
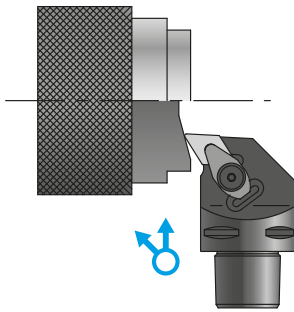

Se muestra el dibujo a la derecha.
Right-hand drawing shown.

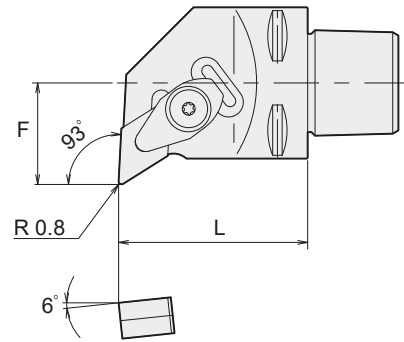

Código Code	Modelo Model	F	L	D1	Kg	Inserto Insert	Accesorios (incluido) - Accessory (included)						
							Lamina Sheet	Lamina de la Clavija de Tope Sheet Stopper Pin	Puente de Sujeción Clamp Bridge	Resorte Spring	Tornillo de retención Clamp Screw	Llave Allen Wrench	
6800 01423101	C4 -DDUN R -27050 - 15	27	50	110									
6800 01423201	L -27050 - 15	27	50	110									
6800 01523101	C5 -DDUN R -35060 - 15	35	60	110		DNM DNG	1504	LLSDN43	LLP24	DCK2613	DCS1	DC0621T	TKY20F
6800 01523201	L -35060 - 15	35	60	110									
6800 01623101	C6 -DDUN R -45065 - 15	45	65	110									
6800 01623201	L -45065 - 15	45	65	110									

- Los insertos no están incluidos. Utilice estándar ISO para los insertos.
- La dimensión D1 muestra los diámetros de corte más pequeños.

- Inserts are not included. Please use ISO Standard inserts.
- The D1 dimension shows the smallest cutting diameter.

Ejemplo para ordenar - Ordering Example

C4 - DDUN R - 27 050 - 15

Medida de zanco Shank size	Modelo Model	Posición Hand	F	L	Longitud de cara Face Length
			F	L	

DDHN

● Doble sujeción / Perfil de Maquinado en Borde • Para exterior

● Double Clamp / For Exterior • Edge Profile Machining

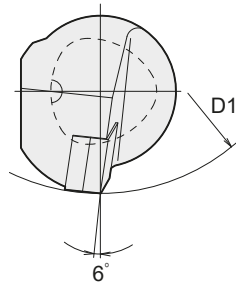
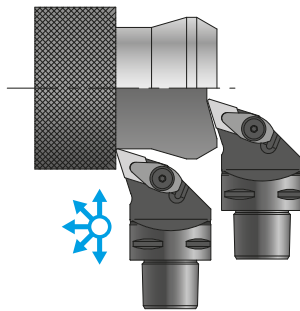

Se muestra el dibujo a la derecha.
Right-hand drawing shown.

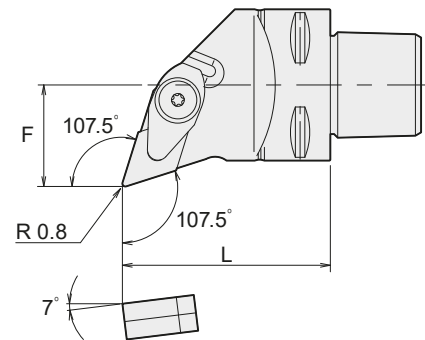

Código Code	Modelo Model	F	L	D1	Kg	Inserto Insert	Accesorios (incluido) - Accessory (included)						
							Lamina Sheet	Lamina de la Clavija de Tope Sheet Stopper Pin	Puente de Sujeción Clamp Bridge	Resorte Spring	Tornillo de retención Clamp Screw	Llave Allen Wrench	
6800 01424101	C4 -DDHN R -27055 - 15	27	55	110									
6800 01424201	L -27055 - 15	27	55	110									
6800 01524101	C5 -DDHN R -35060 - 15	35	60	110		DNM DNG	1504	LLSDN43	LLP24	DCK2613	DCS1	DC0621T	TKY20F
6800 01524201	L -35060 - 15	35	60	110									
6800 01624101	C6 -DDHN R -45065 - 15	45	65	110									
6800 01624201	L -45065 - 15	45	65	110									

- Los insertos no están incluidos. Utilice estándar ISO para los insertos.
- La dimensión D1 muestra los diámetros de corte más pequeños.

- Inserts are not included. Please use ISO Standard inserts.
- The D1 dimension shows the smallest cutting diameter.

Ejemplo para ordenar - Ordering Example

C4 - DDHN R - 27 055 - 15

Medida de zanco Shank size	Modelo Model	Posición Hand	F	L	Longitud de cara Face Length
			F	L	

BT
CAT
AHO
HSK-A/E/F/C
HSK-T
C
UTS
Máquinas Especializadas
Specialized Machine
Equipo Relacionado
Related Equipment
Taladro de Biselado & de Casquillo
Bush & Chamfering Drill
Collet Holder
Side Lock Holder
Milling Chuck
"R" Zero Holder
Hydraulic Chuck
Tapping Chuck
Shrink Fit
Arbors
Turning Tool

DSSN

● Doble Sujeción / Maquinado Exterior • Para Biselado

● Double Clamp / For Chamfering • Exterior Machining

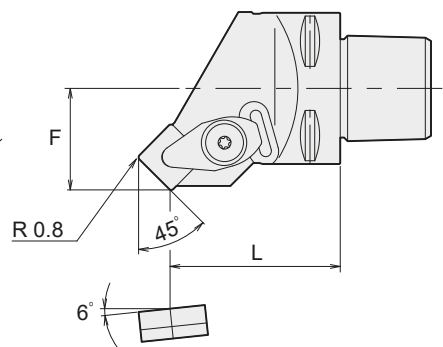
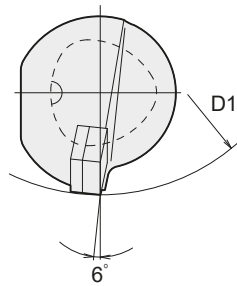
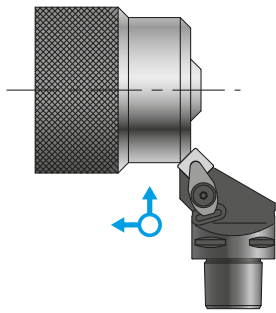

Se muestra el dibujo a la derecha.
Right-hand drawing shown.

Código Code	Modelo Model	F	L	D1	Kg	Inserto Insert	Accesorios (incluido) - Accessory (included)						
							Lamina Sheet	Lamina de la Clavija de Tope Sheet Stopper Pin	Puente de Sujeción Clamp Bridge	Resorte Spring	Tornillo de retención Clamp Screw	Llave Allen Wrench	
6800 01355101	C3 -DSSN R -22045 - 12	22	45	90		SNM SNG	1204	LLSSN42	LLP14	DCK2613	DCS1	DC0621T	TKY20F
6800 01355201	L -22045 - 12	22	45	90									
6800 01455101	C4 -DSSN R -27045 - 12	27	45	110									
6800 01455201	L -27045 - 12	27	45	110									
6800 01555101	C5 -DSSN R -35052 - 12	35	52	110									
6800 01555201	L -35052 - 12	35	52	110									
6800 01655101	C6 -DSSN R -45056 - 12	45	56	110									
6800 01655201	L -45056 - 12	45	56	110									

- Los insertos no están incluidos. Utilice estándar ISO para los insertos.
- La dimensión D1 muestra los diámetros de corte más pequeños.

- Inserts are not included. Please use ISO Standard inserts.
- The D1 dimension shows the smallest cutting diameter.

Ejemplo para ordenar - Ordering Example

C4 - DSSN R - 27 045 - 12

Medida de zanco Shank size	Modelo Model	Posición Hand	F	L	Longitud de cara Face Length
			F	L	

DWLN

● Doble Sujeción / Para Maquinados Generales

● Double Clamp / For General Machining

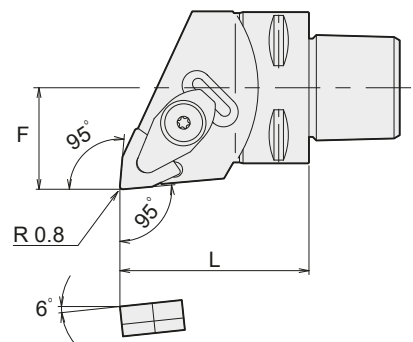
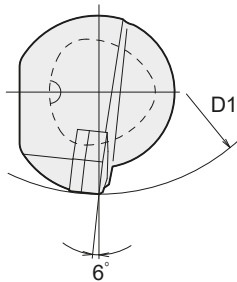
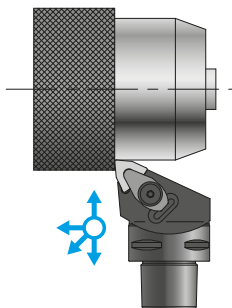

Se muestra el dibujo a la derecha.
Right-hand drawing shown.

Código Code	Modelo Model	F	L	D1	Kg	Inserto Insert	Accesorios (incluido) - Accessory (included)						
							Lamina Sheet	Lamina de la Clavija de Tope Sheet Stopper Pin	Puente de Sujeción Clamp Bridge	Resorte Spring	Tornillo de retención Clamp Screw	Llave Allen Wrench	
6800 01361101	C3 -DWLN R -22040 - 06	22	40	70		WNM WNG	06T3	LLSWN3T3	LLP23	DCK2211	DCS2	DC0520T	TKY15F
6800 01361201	L -22040 - 06	22	40	70									
6800 01461101	C4 -DWLN R -27050 - 08	27	50	110		WNM WNG	0804	LLSWN42	LLP14	DCK2613	DCS1	DC0621T	TKY20F
6800 01461201	L -27050 - 08	27	50	110									
6800 01561101	C5 -DWLN R -35060 - 08	35	60	110									
6800 01561201	L -35060 - 08	35	60	110									
6800 01661101	C6 -DWLN R -45065 - 08	45	65	110									
6800 01661201	L -45065 - 08	45	65	110									

- Los insertos no están incluidos. Utilice estándar ISO para los insertos.
- La dimensión D1 muestra los diámetros de corte más pequeños.

- Inserts are not included. Please use ISO Standard inserts.
- The D1 dimension shows the smallest cutting diameter.

Ejemplo para ordenar - Ordering Example

C4 - DWLN R - 27 050 - 08

Medida de zanco Shank size	Modelo Model	Posición Hand	F	L	Longitud de cara Face Length
			F	L	

DSDN

● Doble Sujeción / Perfil de Maquinado Exterior • Para Biselado

● Double Clamp / For Chamfering • Exterior Profile Machining

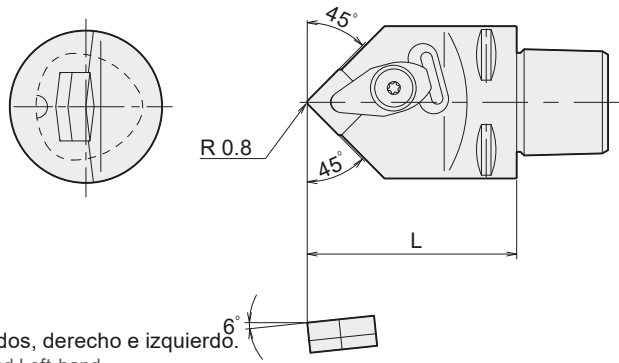
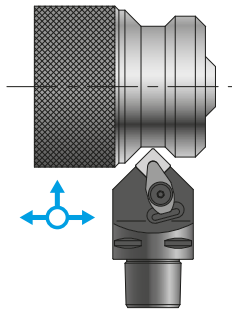

Para ambos lados, derecho e izquierdo.
For both Right and Left-hand.

Código Code	Modelo Model	L	Kg	Inserto Insert	Accesorios (incluido) - Accessory (included)					
					Lamina Sheet	Lamina de la Clavija de Tope Sheet Stopper Pin	Puente de Sujeción Clamp Bridge	Resorte Spring	Tornillo de retención Clamp Screw	Llave Allen Wrench
6800 01358301	C3 -DSDN N -00053 - 12	53								
6800 01458301	C4 -DSDN N -00055 - 12	55		SNM SNG 1204	LLSSN42	LLP14	DCK2613	DCS1	DC0621T	TKY20F
6800 01558301	C5 -DSDN N -00060 - 12	60								
6800 01658301	C6 -DSDN N -00065 - 12	65								

- Los insertos no están incluidos. Utilice estándar ISO para los insertos.
- Inserts are not included. Please use ISO Standard inserts.

Ejemplo para ordenar - Ordering Example

C4 - DSDN N - 00 055 - 12

Medida de zanco | Modelo | F | L | Longitud de cara
Shank size | Model | F | L | Face Length

DSKN

● Doble Sujeción / Para Borde Maquinado de Arrastre

● Double Clamp / For Edge Pull Machining

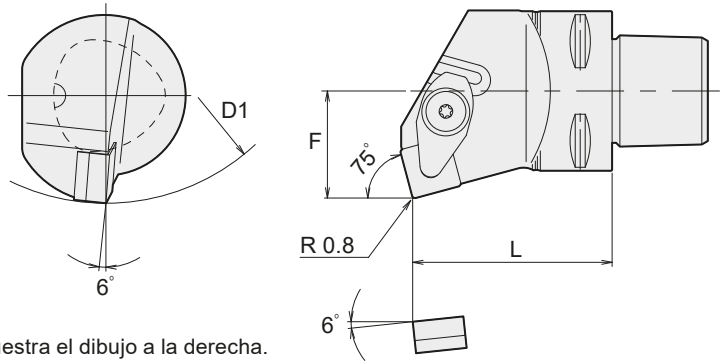
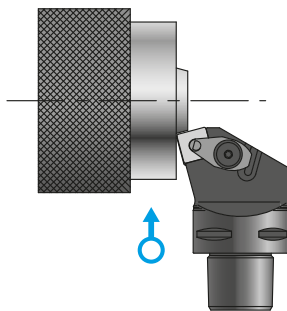

Se muestra el dibujo a la derecha.
Right-hand drawing shown.

Código Code	Modelo Model	F	L	D1	Kg	Inserto Insert	Accesorios (incluido) - Accessory (included)					
							Lamina Sheet	Lamina de la Clavija de Tope Sheet Stopper Pin	Puente de Sujeción Clamp Bridge	Resorte Spring	Tornillo de retención Clamp Screw	Llave Allen Wrench
6800 01457101	C4 -DSKN R -27050 - 12	27	50	110								
6800 01457201	L -27050 - 12	27	50	110								
6800 01557101	C5 -DSKN R -35060 - 12	35	60	110		SNM SNG 1204	LLSSN42	LLP14	DCK2613	DCS1	DC0621T	TKY20F
6800 01557201	L -35060 - 12	35	60	110								
6800 01657101	C6 -DSKN R -45065 - 12	45	65	110								
6800 01657201	L -45065 - 12	45	65	110								

- Los insertos no están incluidos. Utilice estándar ISO para los insertos.
- La dimensión D1 muestra los diámetros de corte más pequeños.
- Inserts are not included. Please use ISO Standard inserts.
- The D1 dimension shows the smallest cutting diameter.

Ejemplo para ordenar - Ordering Example

C4 - DSKN R - 27 050 - 12

Medida de zanco | Modelo | Posición | F | L | Longitud de cara
Shank size | Model | Hand | F | L | Face Length

PCLN

● Palanca de Bloqueo / Para Maquinado General

● Lever Lock / For General Machining

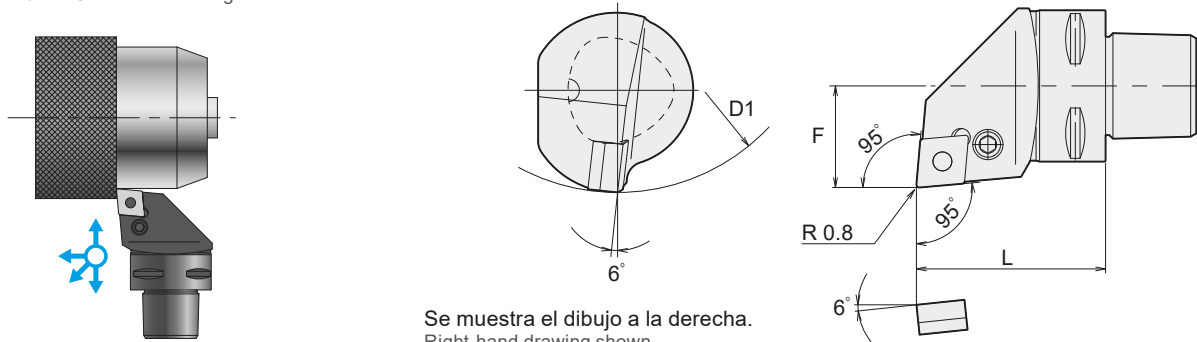

Se muestra el dibujo a la derecha.
Right-hand drawing shown.

Código Code	Modelo Model	F	L	D1	Kg	Inserto Insert	Accesorios (incluido) - Accessory (included)					
							Lamina Sheet	Lamina de la Clavija de Tope Sheet Stopper Pin	Palanca de sujeción Clamp Lever	Tornillo de retención Clamp Screw	Llave Allen Wrench	
6800 02311101	C3 -PCLN R -22040 - 09	22	40	70		0903○○	LLSCN3T3	LLP13	LLCL13	LLCS106	HKY25R	
6800 02311201	L -22040 - 09	22	40	70								
6800 02411101	C4 -PCLN R -27050 - 12	27	50	110		CNMO CNG○	1204○○	LLSCN42	LLP14	LLCL14	LLCS108	HKY30F
6800 02411201	L -27050 - 12	27	50	110								
6800 02511101	C5 -PCLN R -35060 - 12	35	60	110		1204○○	LLSCN42	LLP14	LLCL14	LLCS108	HKY30F	
6800 02511201	L -35060 - 12	35	60	110								
6800 02611101	C6 -PCLN R -45065 - 12	45	65	110		1204○○	LLSCN42	LLP14	LLCL14	LLCS108	HKY30F	
6800 02611201	L -45065 - 12	45	65	110								

1. Los insertos no están incluidos. Utilice estándar ISO para los insertos.

2. La dimensión D1 muestra los diámetros de corte más pequeños.

1. Inserts are not included. Please use ISO Standard inserts.

2. The D1 dimension shows the smallest cutting diameter.

Ejemplo para ordenar - Ordering Example

C4 - PCLN R - 27 050 - 12

Medida de zanco Shank size	Modelo Model	Posición Hand	F	L	Longitud de cara Face Length
			F	L	

PDJN

● Palanca de bloqueo / Perfil de maquinado • para exterior

● Lever Lock / For Exterior • Profile Machining

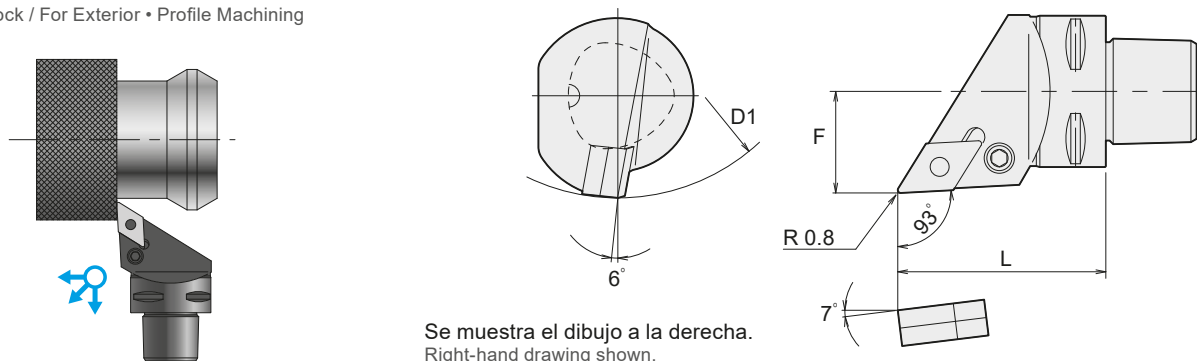

Se muestra el dibujo a la derecha.
Right-hand drawing shown.

Código Code	Modelo Model	F	L	D1	Kg	Inserto Insert	Accesorios (incluido) - Accessory (included)					
							Lamina Sheet	Lamina de la Clavija de Tope Sheet Stopper Pin	Palanca de sujeción Clamp Lever	Tornillo de retención Clamp Screw	Llave Allen Wrench	
6800 02422101	C4 -PDJN R -27055 - 15	27	55	110		DNMO DNG○	1504○○	LLSDN43	LLP14	LLCL24	LLCS108	HKY30R
6800 02422201	L -27055 - 15	27	55	110								
6800 02522101	C5 -PDJN R -35060 - 15	35	60	110		DNMO DNG○	1504○○	LLSDN43	LLP14	LLCL24	LLCS108	HKY30R
6800 02522201	L -35060 - 15	35	60	110								
6800 02622101	C6 -PDJN R -45065 - 15	45	65	110		DNMO DNG○	1504○○	LLSDN43	LLP14	LLCL24	LLCS108	HKY30R
6800 02622201	L -45065 - 15	45	65	110								

1. Los insertos no están incluidos. Utilice estándar ISO para los insertos.

2. La dimensión D1 muestra los diámetros de corte más pequeños.

1. Inserts are not included. Please use ISO Standard inserts.

2. The D1 dimension shows the smallest cutting diameter.

Ejemplo para ordenar - Ordering Example

C4 - PDJN R - 27 055 - 15

Medida de zanco Shank size	Modelo Model	Posición Hand	F	L	Longitud de cara Face Length
			F	L	

PDUN

● Palanca de Bloqueo / Perfil de Maquinado • Para bordes

● Lever Lock / For Edge • Profile Machining

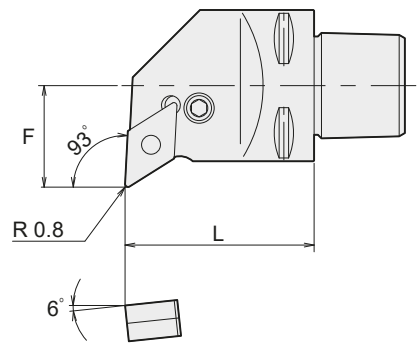
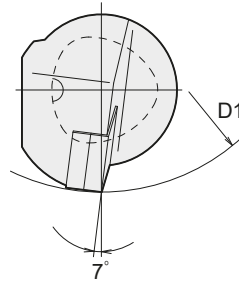
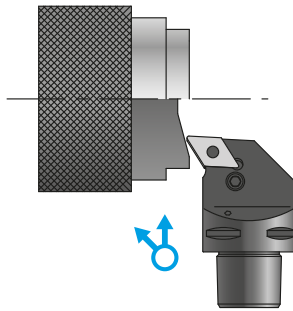

Se muestra el dibujo a la derecha.
Right-hand drawing shown.

Código Code	Modelo Model	F	L	D1	Kg	Inserto Insert	Accesorios (incluido) - Accessory (included)					
							Lamina Sheet	Lamina de la Clavija de Tope Sheet Stopper Pin	Palanca de sujeción Clamp Lever	Tornillo de retención Clamp Screw	Llave Allen Wrench	
6800 02423101	C4 -PDUN R -27050 - 15	27	50	110		DNM○ DNG○	1504○○	LLSDN43	LLP14	LLCL24	LLCS108	HKY30R
6800 02423201	L -27050 - 15	27	50	110								
6800 02523101	C5 -PDUN R -35060 - 15	35	60	110		DNM○ DNG○	1504○○	LLSDN43	LLP14	LLCL24	LLCS108	HKY30R
6800 02523201	L -35060 - 15	35	60	110								
6800 02623101	C6 -PDUN R -45065 - 15	45	65	110		DNM○ DNG○	1504○○	LLSDN43	LLP14	LLCL24	LLCS108	HKY30R
6800 02623201	L -45065 - 15	45	65	110								

1. Los insertos no están incluidos. Utilice estándar ISO para los insertos.

2. La dimensión D1 muestra los diámetros de corte más pequeños.

1. Inserts are not included. Please use ISO Standard inserts.

2. The D1 dimension shows the smallest cutting diameter.

Ejemplo para ordenar - Ordering Example

C4 - PDUN R - 27 050 - 15

Medida de zanco Shank size	Modelo Model	Posición Hand	F	L	Longitud de cara Face Length
			F	L	

PDHN

● Palanca de bloqueo / Perfil de Maquinado en Borde • Para Exterior

● Lever Lock / For Exterior • Edge Profile Machining

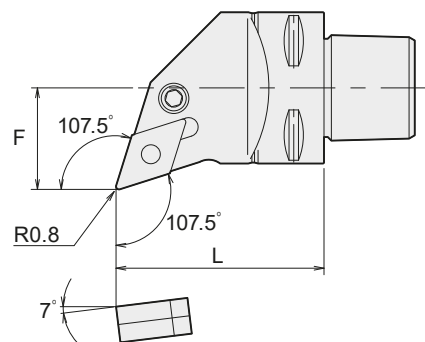
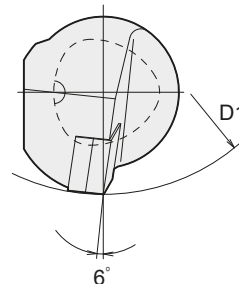
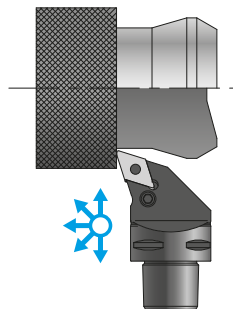

Se muestra el dibujo a la derecha.
Right-hand drawing shown.

Código Code	Modelo Model	F	L	D1	Kg	Inserto Insert	Accesorios (incluido) - Accessory (included)					
							Lamina Sheet	Lamina de la Clavija de Tope Sheet Stopper Pin	Palanca de sujeción Clamp Lever	Tornillo de retención Clamp Screw	Llave Allen Wrench	
6800 02424101	C4 -PDHN R -27055 - 15	27	55	110		DNM○ DNG○	1504○○	LLSDN43	LLP14	LLCL24	LLCS108	HKY30R
6800 02424201	L -27055 - 15	27	55	110								
6800 02524101	C5 -PDHN R -35060 - 15	35	60	110		DNM○ DNG○	1504○○	LLSDN43	LLP14	LLCL24	LLCS108	HKY30R
6800 02524201	L -35060 - 15	35	60	110								
6800 02624101	C6 -PDHN R -45065 - 15	45	65	110		DNM○ DNG○	1504○○	LLSDN43	LLP14	LLCL24	LLCS108	HKY30R
6800 02624201	L -45065 - 15	45	65	110								

1. Los insertos no están incluidos. Utilice estándar ISO para los insertos.

2. La dimensión D1 muestra los diámetros de corte más pequeños.

1. Inserts are not included. Please use ISO Standard inserts.

2. The D1 dimension shows the smallest cutting diameter.

Ejemplo para ordenar - Ordering Example

C4 - PDHN R - 27 055 - 15

Medida de zanco Shank size	Modelo Model	Posición Hand	F	L	Longitud de cara Face Length
			F	L	

BT
CAT
AHO
HSK-A/E/F/C
HSK-T
C
UTS
Máquinas Especializadas Specialized Machine
Equipo Relacionado Related Equipment
Taladro de Biselado & de Casquillo Bush & Chamfering Drill
Collet Holder
Side Lock Holder
Milling Chuck
R- Zero Holder
Hydraulic Chuck
Tapping Chuck
Shrink Fit
Arbors
Turning Tool

PSSN

● Palanca de bloqueo / Perfil de Maquinado • Para Exterior

● Lever Lock / For Exterior • Profile Machining

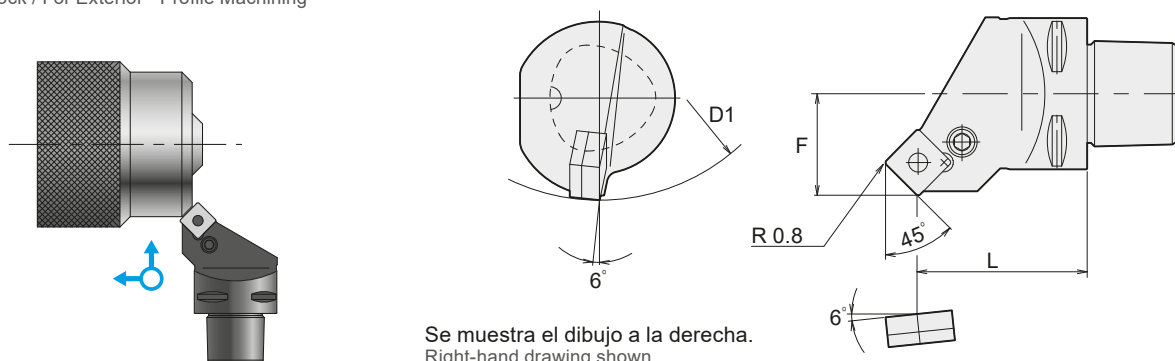

Se muestra el dibujo a la derecha.
Right-hand drawing shown.

Código Code	Modelo Model	F	L	D1	Kg	Inserto Insert	Accesorios (incluido) - Accessory (included)				
							Lamina Sheet	Lamina de la Clavija de Tope Sheet Stopper Pin	Palanca de sujeción Clamp Lever	Tornillo de retención Clamp Screw	Llave Allen Wrench
6800 02355101	C3 -PSSN R -22045 - 12	22	45	90		SNM○ SNG○ 1204○○	LLSSN42	LLP14	LLCL14	LLCS108	HKY30R
6800 02355201	L -22045 - 12	22	45	90							
6800 02455101	C4 -PSSN R -27045 - 12	27	45	110							
6800 02455201	L -27045 - 12	27	45	110							
6800 02555101	C5 -PSSN R -35052 - 12	35	52	110							
6800 02555201	L -35052 - 12	35	52	110							
6800 02655101	C6 -PSSN R -45056 - 12	45	56	110							
6800 02655201	L -45056 - 12	45	56	110							

1. Los insertos no están incluidos. Utilice estándar ISO para los insertos.

2. La dimensión D1 muestra los diámetros de corte más pequeños.

1. Inserts are not included. Please use ISO Standard inserts.

2. The D1 dimension shows the smallest cutting diameter.

Ejemplo para ordenar - Ordering Example

C4 - PSSN R - 27 045 - 12

Medida de zanco Shank size	Modelo Model	Posición Hand	F	L	Longitud de cara Face Length
			F	L	

PSDN

● Palanca de Bloqueo / Perfil de Maquinado Exterior • Para Biselado

● Lever Lock / For Chamfering • Exterior Profile Machining

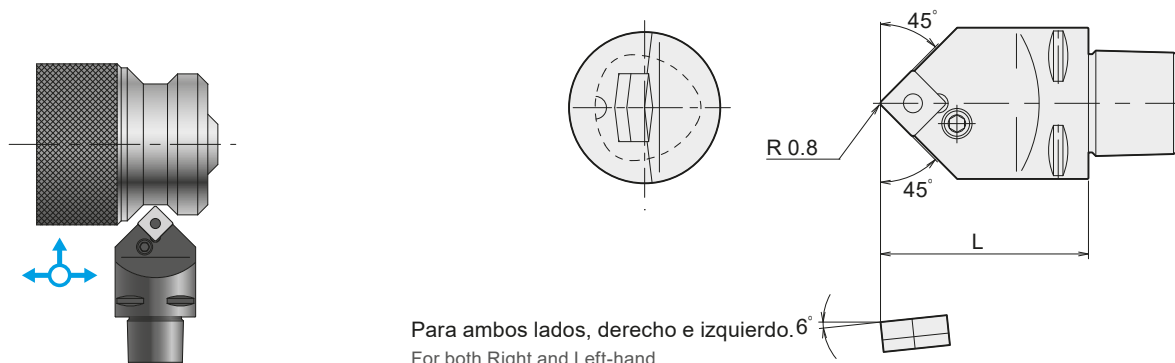

Para ambos lados, derecho e izquierdo. 6°
For both Right and Left-hand.

Código Code	Modelo Model	L	Kg	Inserto Insert	Accesorios (incluido) - Accessory (included)				
					Lamina Sheet	Lamina de la Clavija de Tope Sheet Stopper Pin	Palanca de sujeción Clamp Lever	Tornillo de retención Clamp Screw	Llave Allen Wrench
6800 02358301	C3 -PSDN N -00053 - 12	53		SNM○ SNG○ 1204○○	LLSSN42	LLP14	LLCL14	LLCS108	HKU30R
6800 02458301	C4 -PSDN N -00055 - 12	55							
6800 02558301	C5 -PSDN N -00060 - 12	60							
6800 02658301	C6 -PSDN N -00065 - 12	65							

1. Los insertos no están incluidos. Utilice estándar ISO para los insertos.

1. Inserts are not included. Please use ISO Standard inserts.

Ejemplo para ordenar - Ordering Example

C4 - PSDN N - 27 055 - 12

Medida de zanco Shank size	Modelo Model	F	L	Longitud de cara Face Length
		F	L	

PSKN

● Palanca de Bloqueo / Maquinado de Arrastre • Para Borde

● Lever Lock / For Edge • Pull Machining

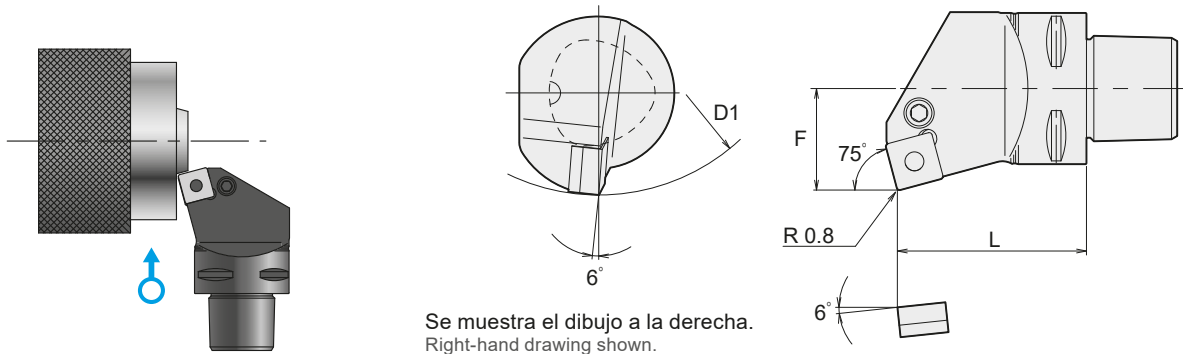

Se muestra el dibujo a la derecha.
Right-hand drawing shown.

Código Code	Modelo Model	F	L	D1	Kg	Inserto Insert	Accesorios (incluido) - Accessory (Included)				
							Lamina Sheet	Lamina de la Clavija de Tope Sheet Stopper Pin	Palanca de sujeción Clamp Lever	Tornillo de retención Clamp Screw	Llave Allen Wrench
6800 02457101	C4 -PSKN R -27050 - 12	27	50	110		SNM○ SNG○ 1204○○	LLSSN42	LLP14	LLCL14	LLCS108	HKY30R
6800 02457201	L -27050 - 12	27	50	110							
6800 02557101	C5 -PSKN R -35060 - 12	35	60	110							
6800 02557201	L -35060 - 12	35	60	110							
6800 02657101	C6 -PSKN R -45065 - 12	45	65	110							
6800 02657201	L -45065 - 12	45	65	110							

1. Los insertos no están incluidos. Utilice estándar ISO para los insertos.

2. La dimensión D1 muestra los diámetros de corte más pequeños.

1. Inserts are not included. Please use ISO Standard inserts.

2. The D1 dimension shows the smallest cutting diameter.

Ejemplo para ordenar - Ordering Example

C4		- PSKN		R		- 27 050		- 12	
Medida de zanco Shank size	Modelo Model	Posición Hand	F	L	Longitud de cara Face Length	F	L	F	L

- BT
- CAT
- AHO
- HSK-A/E/F/C
- HSK-T
- C**
- UTS
- Máquinas Especializadas
Specialized Machine
- Equipo Relacionado
Related Equipment
- Taladro de Biselado & de Casquillo
Bush & Chamfering Drill
- Collet Holder
- Side Lock Holder
- Milling Chuck
- "R" Zero Holder
- Hydraulic Chuck
- Tapping Chuck
- Shrink Fit
- Arbors
- Turning Tool

SVJB

● Atornillado / Perfil de Maquinado • Para Exterior

● Screw-On / For Exterior • Profile Machining

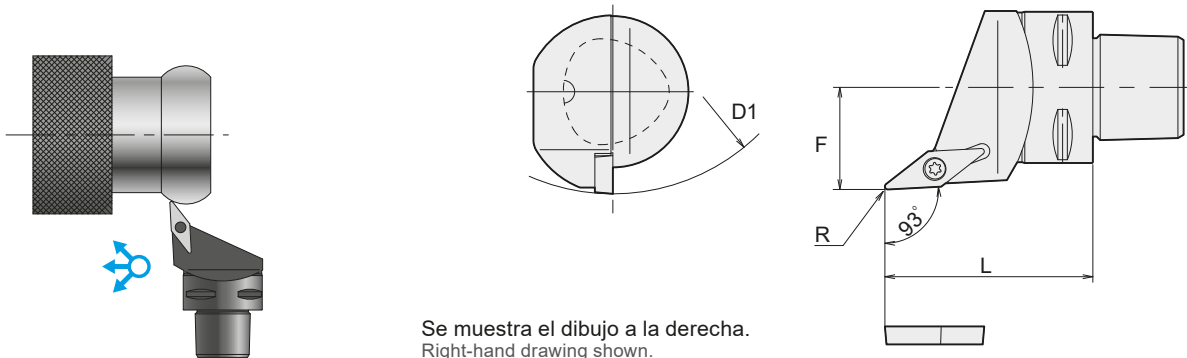

Se muestra el dibujo a la derecha.
Right-hand drawing shown.

Código Code	Modelo Model	F	L	D1	R	Kg	Inserto Insert	Accesorios (incluido) - Accessory (included)	
								Tornillo de retención Clamp Screw	Llave Allen Wrench
6800 03332101	C3 -SVJB R -22045 - 11	22	45	70	0.4		VBM○ 1103○○	TS25	TKY08F
6800 03332201	L -22045 - 11	22	45	70	0.4		VBG○ 1103○○		
6800 03432101	C4 -SVJB R -27055 - 16	27	55	110	0.8		VBM○ 1604○○	TS43	TKY15F
6800 03432201	L -27055 - 16	27	55	110	0.8				
6800 03532101	C5 -SVJB R -35060 - 16	35	60	110	0.8		VBM○ 1604○○	TS43	TKY15F
6800 03532201	L -35060 - 16	35	60	110	0.8				
6800 03632101	C6 -SVJB R -45065 - 16	45	65	110	0.8		VBM○ 1604○○	TS43	TKY15F
6800 03632201	L -45065 - 16	45	65	110	0.8				

1. Los insertos no están incluidos. Utilice estándar ISO para los insertos.

2. La dimensión D1 muestra los diámetros de corte más pequeños.

1. Inserts are not included. Please use ISO Standard inserts.

2. The D1 dimension shows the smallest cutting diameter.

Ejemplo para ordenar - Ordering Example

C4	-SVJB	R	- 27 055	- 16
Medida de zanco Shank size	Modelo Model	Posición Hand	F F	L L
				Longitud de cara Face Length

SVQB

● Atornillado / Perfil de Maquinado en Borde • Para Exterior

● Screw-On / For Exterior • Edge Profile Machining

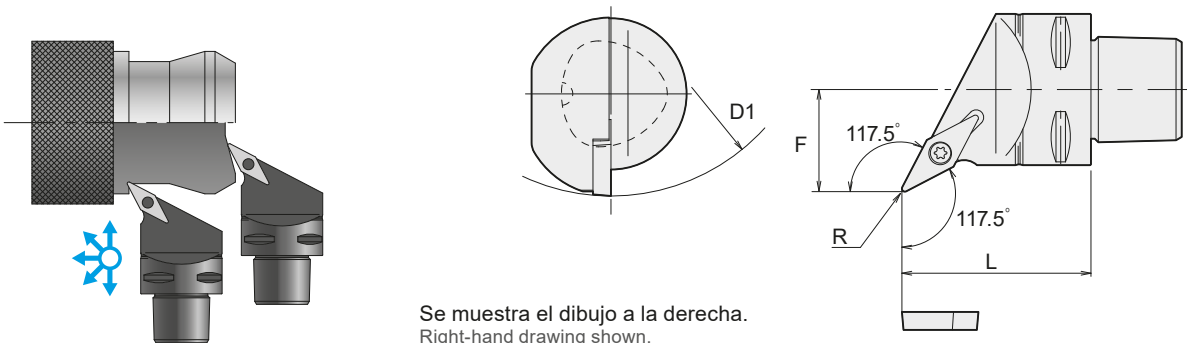

Se muestra el dibujo a la derecha.
Right-hand drawing shown.

Código Code	Modelo Model	F	L	D1	R	Kg	Inserto Insert	Accesorios (incluido) - Accessory (included)	
								Tornillo de retención Clamp Screw	Llave Allen Wrench
6800 03339101	C3 -SVQB R -22040 - 11	22	40	70	0.4		VBM○ 1103○○	TS25	TKY08F
6800 03339201	L -22040 - 11	22	40	70	0.4		VBG○ 1103○○		
6800 03439101	C4 -SVQB R -27050 - 16	27	50	110	0.8		VBM○ 1604○○	TS43	TKY15F
6800 03439201	L -27050 - 16	27	50	110	0.8				
6800 03539101	C5 -SVQB R -35060 - 16	35	60	110	0.8		VBM○ 1604○○	TS43	TKY15F
6800 03539201	L -35060 - 16	35	60	110	0.8				
6800 03639101	C6 -SVQB R -45065 - 16	45	65	110	0.8		VBM○ 1604○○	TS43	TKY15F
6800 03639201	L -45065 - 16	45	65	110	0.8				

1. Los insertos no están incluidos. Utilice estándar ISO para los insertos.

2. La dimensión D1 muestra los diámetros de corte más pequeños.

1. Inserts are not included. Please use ISO Standard inserts.

2. The D1 dimension shows the smallest cutting diameter.

Ejemplo para ordenar - Ordering Example

C4	-SVQB	R	- 27 050	- 16
Medida de zanco Shank size	Modelo Model	Posición Hand	F F	L L
				Longitud de cara Face Length

SVVB

● Atornillado / Perfil de Maquinado • Para Exterior

● Screw-On / For Exterior • Profile Machining

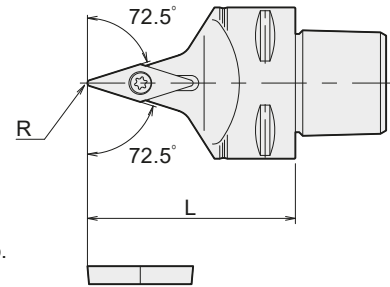
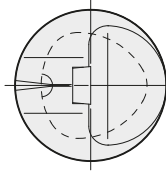
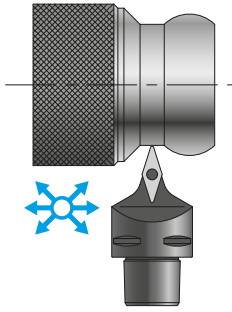

Para ambos lados, derecho e izquierdo.
For both Right and Left-hand.

Código Code	Modelo Model	L	R	Kg	Inserto Insert	Accesorios (incluido) - Accessory (included)	
						Tornillo de retención Clamp Screw	Llave Allen Wrench
6800 03330301	C3 -SVVB N -00045 - 11	45	0.4		VBM○ VBG○ 1103○○	TS25	TKY08F
6800 03430301	C4 -SVVB N -00055 - 16	55	0.8		VBM○ VBG○ 1604○○	TS43	TKY15F
6800 03530301	C5 -SVVB N -00060 - 16	60	0.8				
6800 03630301	C6 -SVVB N -00065 - 16	65	0.8				

1. Los insertos no están incluidos. Utilice estándar ISO para los insertos.

1. Inserts are not included. Please use ISO Standard inserts.

Ejemplo para ordenar - Ordering Example

C4 - SVVB N - 00 055 - 16					
Medida de zanco Shank size	Modelo Model	F	L	Longitud de cara Face Length	
		F	L		

- BT
- CAT
- AHO
- HSK-A/E/F/C
- HSK-T
- C**
- UTS
- Máquinas Especializadas
Specialized Machine
- Equipo Relacionado
Related Equipment
- Taladro de Biselado & de Casquillo
Bush & Chamfering Drill
- Collet Holder
- Side Lock Holder
- Milling Chuck
- "R" Zero Holder
- Hydraulic Chuck
- Tapping Chuck
- Shrink Fit
- Arbors
- Turning Tool

DCLN

● Doble Sujeción / Maquinado en Borde • Para Interior

● Double Clamp / For Interior • Edge Machining

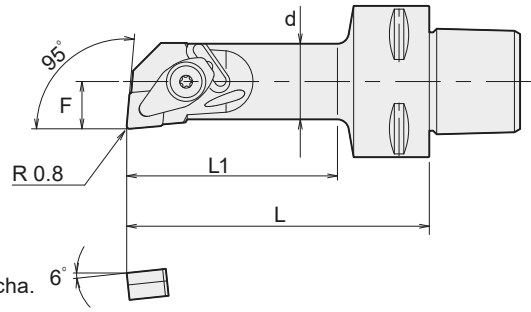
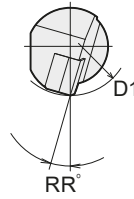
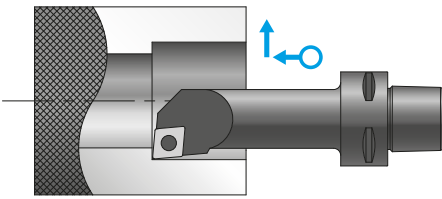

Se muestra el dibujo a la derecha.
Right-hand drawing shown.

Código Code	Modelo Model	F	L	L1	d	D1	RR	Kg	Inserto Insert	Accesorios (incluido) - Accessory (included)					
										Lamina Sheet	Lamina de la Clavija de Tope Sheet Stopper Pin	Puente de Sujeción Clamp Bridge	Resorte Spring	Tornillo de retención Clamp Screw	Llave Allen Wrench
6800 01411111	C4 -DCLN R -13080 - 09	13	80	56	20	32	16		CNM 0903	LLSCN3T3	LLP23	DCK2211	DCS2	DC0520T	TKY15F
6800 01411211	L -13080 - 09	13	80	56	20	32	16		CNG						
6800 01511111	C5 -DCLN R -17090 - 12	17	90	65	25	40	15		CNM 1204	LLSCN42	LLP14	DCK2613	DCS1	DC0621T	TKY20F
6800 01511211	L -17090 - 12	17	90	65	25	40	15		CNG						
6800 01611111	C6 -DCLN R -27140 - 12	27	140	113	40	50	10		CNM 1204						
6800 01611211	L -27140 - 12	27	140	113	40	50	10		CNG						

- Los insertos no están incluidos. Utilice estándar ISO para los insertos.
- La dimensión D1 muestra los diámetros de corte más pequeños.

Ejemplo para ordenar - Ordering Example

C4 - DCLN R - 13 080 - 09

Medida de zanco Shank size	Modelo Model	Posición Hand	F	L	Longitud de cara Face Length
			F	L	

DDUN

● Doble sujeción / Perfil de Maquinado • Para Interior

● Double Clamp / For Interior • Profile Machining

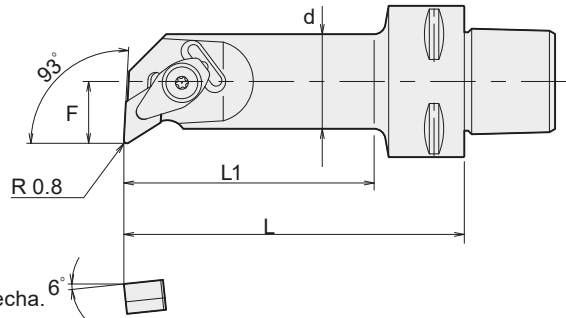
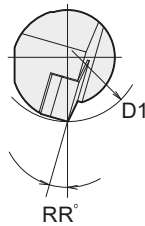
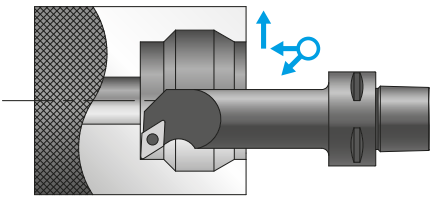

Se muestra el dibujo a la derecha.
Right-hand drawing shown.

Código Code	Modelo Model	F	L	L1	d	D1	RR	Kg	Inserto Insert	Accesorios (incluido) - Accessory (included)					
										Lamina Sheet	Lamina de la Clavija de Tope Sheet Stopper Pin	Puente de Sujeción Clamp Bridge	Resorte Spring	Tornillo de retención Clamp Screw	Llave Allen Wrench
6800 01423111	C4 -DDUN R -17090 - 11	17	90	66	25	40	16		DNM 1104	LLSDN32	LLP23	DCK2211	DCS2	DC0520T	TKY15F
6800 01423211	L -17090 - 11	17	90	66	25	40	16		DNG						
6800 01523111	C5 -DDUN R -27140 - 15	27	140	117	40	50	12		DNM 1504	LLSDN43	LLP24	DCK2613	DCS1	DC0621T	TKY20F
6800 01523211	L -27140 - 15	27	140	117	40	50	12		DNG						
6800 01623111	C6 -DDUN R -27140 - 15	27	140	113	40	50	12		DNM 1504						
6800 01623211	L -27140 - 15	27	140	113	40	50	12		DNG						

- Los insertos no están incluidos. Utilice estándar ISO para los insertos.
- La dimensión D1 muestra los diámetros de corte más pequeños.

Ejemplo para ordenar - Ordering Example

C4 - DDUN R - 17 090 - 11

Medida de zanco Shank size	Modelo Model	Posición Hand	F	L	Longitud de cara Face Length
			F	L	

SVQB

- Atornillado / Para maquinado de corte inferior
- Screw-On / For Undercut Machining

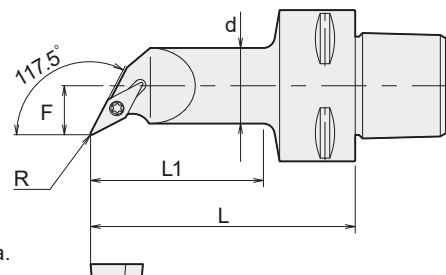
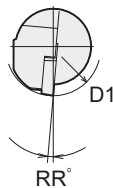
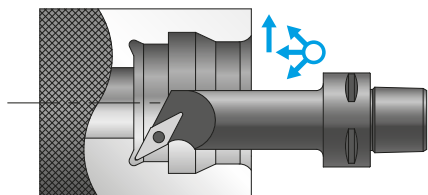

Se muestra el dibujo a la derecha.
Right-hand drawing shown.

Código Code	Modelo Model	F	L	L1	d	D1	RR	R	Kg	Inserto Insert	Accesorios (incluido) - Accessory (included)		
											Tornillo de retención Clamp Screw	Llave Allen Wrench	
6800 03339111	C3 -SVQB R -13070 - 11	13	70	49	16	22	8	0.4		VBM○ VBG○	1103○○	TS25	TKY08F
6800 03339211	L -13070 - 11	13	70	49	16	22	8	0.4					
6800 03439111	C4 -SVQB R -13070 - 11	13	70	46	20	25	5	0.4		VBM○ VBG○	1103○○	TS43	TKY15F
6800 03439211	L -13070 - 11	13	70	46	20	25	5	0.4					
6800 03539111	C5 -SVQB R -22110 - 16	22	110	86	32	40	7	0.8		VBM○ VBG○	1604○○		
6800 03539211	L -22110 - 16	22	110	86	32	40	7	0.8					
6800 03639111	C6 -SVQB R -27145 - 16	27	145	118	40	50	5	0.8		VBM○ VBG○	1604○○		
6800 03639211	L -27145 - 16	27	145	118	40	50	5	0.8					

- Los insertos no están incluidos. Utilice estándar ISO para los insertos.
- La dimensión D1 muestra los diámetros de corte más pequeños.
- Inserts are not included. Please use ISO Standard inserts.
- The D1 dimension shows the smallest cutting diameter.

Ejemplo para ordenar - Ordering Example

C4 - SVQB R - 13 070 - 11

Medida de zanco Shank size	Modelo Model	Posición Hand	F F	L L	Longitud de cara Face Length
-------------------------------	-----------------	------------------	--------	--------	---------------------------------

SDZC

- Atornillado / Para Maquinado a Espaldas de la Barra
- Screw-On / For Back Boring Machining

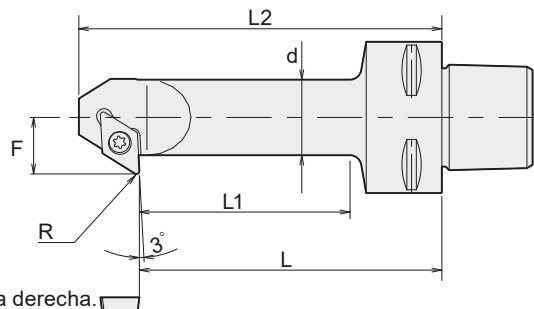
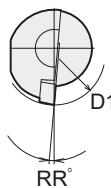
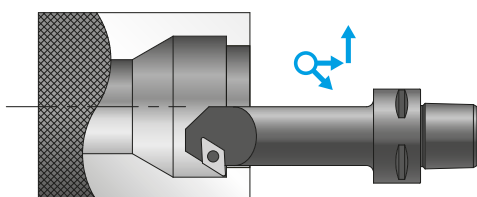

Se muestra el dibujo a la derecha.
Right-hand drawing shown.

Código Code	Modelo Model	F	L	L1	L2	d	D1	RR	R	Kg	Inserto Insert	Accesorios (incluido) - Accessory (included)	
												Tornillo de retención Clamp Screw	Llave Allen Wrench
6800 03325111	C3 -SDZC R -15080 - 11	15	80	59	96	20	27	5	0.8			TS43	TKY15F
6800 03325211	L -15080 - 11	15	80	59	96	20	27	5	0.8				
6800 03425111	C4 -SDZC R -15080 - 11	15	80	56	96	20	27	5	0.8		DCM○ DCG○	11T3○○	TKY15F
6800 03425211	L -15080 - 11	15	80	56	96	20	27	5	0.8				
6800 03525111	C5 -SDZC R -18090 - 11	18	90	65	106	25	32	8	0.8				
6800 03525211	L -18090 - 11	18	90	65	106	25	32	8	0.8				

- Los insertos no están incluidos. Utilice estándar ISO para los insertos.
- La dimensión D1 muestra los diámetros de corte más pequeños.
- Inserts are not included. Please use ISO Standard inserts.
- The D1 dimension shows the smallest cutting diameter.

Ejemplo para ordenar - Ordering Example

C4 - SDZC R - 15 080 - 11

Medida de zanco Shank size	Modelo Model	Posición Hand	F F	L L	Longitud de cara Face Length
-------------------------------	-----------------	------------------	--------	--------	---------------------------------

C
UTS
Máquinas Especializadas Specialized Machine
Equipo Relacionado Related Equipment
Taladro de Biselado & de Casquillo Bush & Chamfering Drill
Collet Holder
Side Lock Holder
Milling Chuck
"R" Zero Holder
Hydraulic Chuck
Tapping Chuck
Shrink Fit
Arbors
Turning Tool

STFC

● Atornillado / Para Maquinado General de Barra

● Screw-On / For General Boring Machining

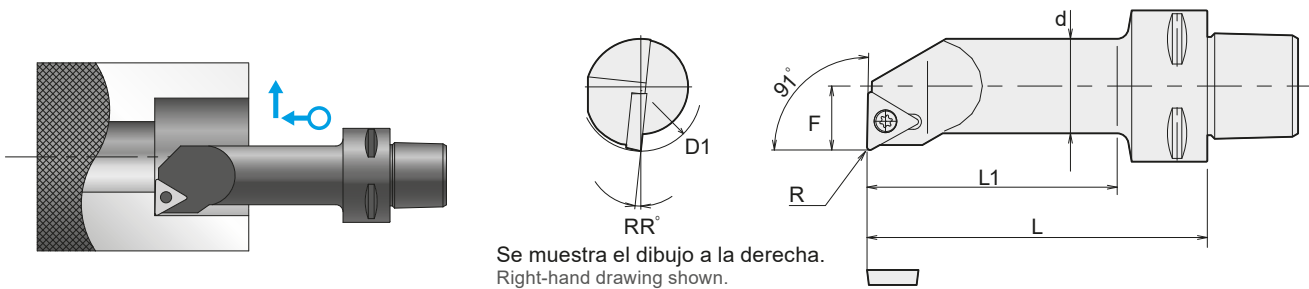

Se muestra el dibujo a la derecha.
Right-hand drawing shown.

Código Code	Modelo Model	F	L	L1	d	D1	RR	R	Kg	Inserto Insert	Accesorios (incluido) - Accessory (included)		
											Tornillo de retención Clamp Screw	Llave Allen Wrench	
6800 03341111	C3 -STFC R -13075 - 16	13	75	54	20	25	7	0.8		TCM TCG	16T3	TS43	TKY15F
6800 03341211	L -13075 - 16	13	75	54	20	25	7	0.8					
6800 03441111	C4 -STFC R -17090 - 16	17	90	66	25	32	6	0.8					
6800 03441211	L -17090 - 16	17	90	66	25	32	6	0.8					
6800 03541111	C5 -STFC R -22110 - 16	22	110	86	32	40	5	0.8					
6800 03541211	L -22110 - 16	22	110	86	32	40	5	0.8					

1. Los insertos no están incluidos. Utilice estándar ISO para los insertos.

2. La dimensión D1 muestra los diámetros de corte más pequeños.

1. Inserts are not included. Please use ISO Standard inserts.

2. The D1 dimension shows the smallest cutting diameter.

Ejemplo para ordenar - Ordering Example

C4	- STFC	R	- 17 090	-	16
Medida de zanco Shank size	Modelo Model	Posición Hand	F F	L L	Longitud de cara Face Length

- BT
- CAT
- AHO
- HSK A/E/F/C
- HSK-T
- C**
- UTS
- Máquinas Especializadas
Specialized Machine
- Equipo Relacionado
Related Equipment
- Taladro de Biselado & de Casquillo
Bush & Chamfering Drill
- Collet Holder
- Side Lock Holder
- Milling Chuck
- "R" Zero Holder
- Hydraulic Chuck
- Tapping Chuck
- Shrink Fit
- Arbors
- Turning Tool



U T S

SISTEMA DE HERRAMENTADO UTS

UTS TOOLING SYSTEM

Al hacer su orden, favor de especificar si requiere presión alta o baja.

Favor de revisar el tipo de husillo en su máquina.

Para el tipo de presión alta, favor de agregar (-H) al final de la descripción.

When placing an order, please specify high or low pressure.

Please check your machine spindle type.

For high pressure type, please add (-H) on end of the description.

Super tite-lock Milling Chuck

- Super tite-lock delgado. Sus ranuras tienen un diseño especial para permitir desbastes pesados.
- Slim design milling chuck. Specially designed slits enable heavy endmilling.

Tipo1
Type1

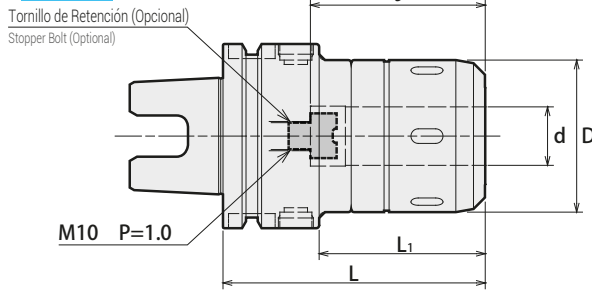

Tipo2
Type2

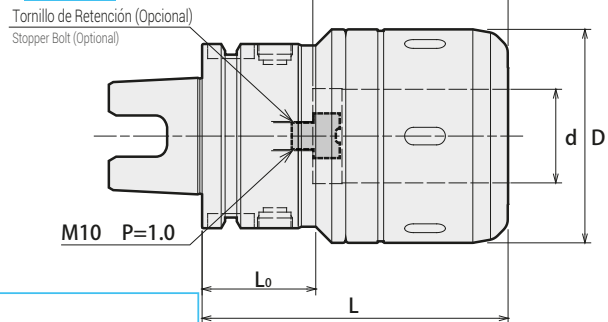

⚠ Precaución / Caution
 Favor de girar el anillo de sujeción en sentido contrario a las manecillas del reloj por más de 360 grados después de remover una herramienta de corte.
 Please rotate the clamping ring counterclockwise more than 360 degrees after a cutting tool is removed.

Medidas Métricas - Metric Sizes

Unidad : Métrico
Unit : Metric

Código Code	Modelo Model	Tipo Type	d	D	L	L ₁	ℓ	L ₀	Max. min ⁻¹	kg	Llave Inglesa Spanner	
1360 01116090	UTS5040 -CT16SA - 90 -H * 1	1	16	45	90	60	60	-	16,000	1.1	HS-1-16	
1360 01120090	UTS5040 -CT20SA - 90 -H * 1	2	20	52	90	60	60	35	14,000	1.3	HS-2-20	
1360 01120105	- 105 -H * 1	2	20	52	105	75	75	50	12,000	1.5	HS-2-20	
1360 01125105	UTS5040 -CT25SA - 105 -H * 1	2	25	61	105	75	75	35	10,000	1.8	HS-2.5-25	
1360 0 * 216090	UTS6350 -CT16SA - 90	1	16	45	90	57	65	-	20,000	1.5	HS-1-16	
1360 0 * 220090	UTS6350 -CT20SA - 90	* 1	1	20	52	90	57	65	-	18,000	1.6	HS-2-20
1360 0 * 220105	- 105	1	20	52	105	72	75	-	17,000	1.8	HS-2-20	
1360 0 * 220135	- 135	1	20	52	135	102	80	-	15,000	2.2	HS-2.5-25	
1360 0 * 225105	UTS6350 -CT25SA - 105	1	25	61	105	72	75	-	15,000	2.1	HS-2.5-25	
1360 0 * 225120	- 120	1	25	61	120	87	75	-	14,000	2.5	HS-2.5-25	
1360 0 * 225135	- 135	1	25	61	135	102	80	-	12,000	2.8	HS-3-32	
1360 0 * 232105	UTS6350 -CT32SA - 105 * 1	2	32	73	105	72	80	39	11,000	2.5	HS-3-32	
1360 0 * 232120	- 120 * 1	2	32	73	120	87	90	54	10,000	2.8	HS-3-32	
1360 0 * 232150	- 150 * 1	2	32	73	150	117	120	84	10,000	3.3	HS-1-16	
1360 0 * 316090	UTS10080 -CT16SA - 90	1	16	45	90	56	65	-	12,500	3.0	HS-1-16	
1360 0 * 316105	- 105	1	16	45	105	71	65	-	12,500	3.4	HS-2-20	
1360 0 * 320090	UTS10080 -CT20SA - 90 * 1	1	20	52	90	56	65	-	12,500	3.2	HS-2-20	
1360 0 * 320105	- 105 * 2	1	20	52	105	71	70	-	12,500	3.5	HS-2-20	
1360 0 * 320120	- 120	1	20	52	120	86	80	-	12,500	3.9	HS-2.5-25	
1360 0 * 320135	- 135	1	20	52	135	101	80	-	12,500	4.2	HS-2.5-25	
1360 0 * 320150	- 150	1	20	52	150	116	80	-	12,500	4.6	HS-2.5-25	
1360 0 * 325105	UTS10080 -CT25SA - 105 * 2	1	25	61	105	71	70	-	12,500	3.8	HS-2.5-25	
1360 0 * 325120	- 120	1	25	61	120	86	80	-	12,500	4.1	HS-2.5-25	
1360 0 * 325135	- 135	1	25	61	135	101	80	-	12,500	4.5	HS-3-32	
1360 0 * 325150	- 150	1	25	61	150	116	80	-	12,500	5.0	HS-3-32	
1360 0 * 332105	UTS10080 -CT32SA - 105 * 1	1	32	73	105	71	70	-	12,000	4.2	HS-3-32	
1360 0 * 332120	- 120 * 1	1	32	73	120	86	85	-	12,000	4.6	HS-3-32	
1360 0 * 332135	- 135 * 1	1	32	73	135	101	100	-	12,000	5.0	HS-4-42	
1360 0 * 332150	- 150 * 1	1	32	73	150	116	115	-	12,000	5.4	HS-4-42	
1360 0 * 342120	UTS10080 -CT42SA - 120 * 1	1	42	88	120	86	85	-	10,000	5.4	HS-4-42	
1360 0 * 342135	- 135 * 1	1	42	88	135	101	100	-	10,000	6.0	HS-4-42	
1360 0 * 342150	- 150 * 1	1	42	88	150	116	110	-	10,000	6.6	HS-4-42	
1360 0 * 342165	- 165 * 1	1	42	88	165	131	120	-	10,000	7.2	HS-4-42	

Al hacer su orden, favor de especificar entre presión alta o baja. Favor de revisar el tipo de husillo en su máquina. Para el tipo de presión alta, favor de agregar (-H) al final de la descripción.

1. Al hacer su orden, indique el número de llaves que necesitará. Las llaves inglesas "gratuitas" están limitadas al número de portaherramientas de fresado que ordene.
2. La tolerancia del zanco de la herramienta de corte debe ser de h7.
3. El UTS5040 sólo está disponible en presión alta.
4. La velocidad permitida varía mucho según la rigidez del husillo en la máquina y del balance de la herramienta de corte. Aumente gradualmente la velocidad a partir de la baja y úselo en la velocidad adecuada.

When placing an order, please specify high or low pressure. For high pressure type, please add (-H) on end of the description.

1. When ordering, indicate number of spanners required. "Complimentary" spanners are limited to number of milling chucks on order.
2. Tolerance of cutting tool shank must be h7.
3. Only high pressure type is available for UTS5040.
4. Permissible speed is greatly affected by the stiffness of the machine spindle and the balance of the cutting tool. Gradually increase from a low speed, and use at the proper speed.

Accesorios Accessories

Los modelos con * 1 - * 4 no pueden usarse con algunos accesorios debido a la corta l longitud.
Models with * 1 - * 3 cannot be used with some accessories due to short l length.

	Tornillo de retención Stopper Bolt BL (Pág.72)	Boquilla recta Straight Collet		Adaptador Morse Morse Taper Adapter		Adaptador Jacobs Jacobs Adapter	
		MC (Pág.070)	MCA (Pág.071)	MA (Pág.072)	MAB (Pág.072)	JA (Pág.073)	JAB (Pág.073)
* 1	BL16 únicamente / only	Sí / Yes	No	Sí / Yes	Sí / Yes	Sí / Yes	Sí / Yes
* 2	BL16 únicamente / only	Sí / Yes	No	No	Sí / Yes	No	Sí / Yes

Longitud Mínima de inserción Min. chucking length

Sin boquilla MC - Without MC collet

D.I. del portaherramienta de fresado I.D. of Milling Chuck	Longitud mín de inserción Min. chucking length
16, 20	40
25, 32, 42	50

Sin boquilla MC - Without MC collet

D.I. del portaherramienta de fresado I.D. of Milling Chuck	Longitud mín de inserción Min. chucking length
16mm, 20mm	40mm (1.575")
25mm, 32mm, 42mm	50mm (1.969")

Con boquilla MC - With MC collet

D.I. de la boquilla Collet I.D.	Longitud mín de inserción Min. chucking length	
	MC	MC-C, MC-OH
6, 8	30	30
10, 12	40	40
16, 20	45	45
25	50	50
32	50	60

Con boquilla MC - With MC collet

D.I. de la boquilla Collet I.D.	Longitud mín de inserción Min. chucking length	
	MC	MC-C, MC-OH
6mm, 8mm	30mm (1.181")	30mm (1.181")
10mm, 12mm	40mm (1.575")	40mm (1.575")
16mm, 18mm, 20mm	45mm (1.772")	45mm (1.772")
25mm	50mm (1.969")	50mm (1.969")
32mm	50mm (1.969")	60mm (2.362")

Ejemplo para Ordenar - Ordering Example

Tipo de baja presión - Low pressure type
0 ~ 1.0MPa (UTS10080 : 0 ~ 2.0MPa)

UTS6350 - CT 32 S - 105

Interfaz y diámetro de husillo
Shank size

Diámetro Interior
I.D. (d)

Longitud de Proyección
Projection length (L)

Ejemplo para Ordenar - Ordering Example

Tipo de alta presión - High pressure type
1.1 ~ 7.0MPa (UTS10080 : 2.1 ~ 7.0MPa)

UTS6350 - CT 32 S - 105 - H

Interfaz y diámetro de husillo
Shank size

Diámetro Interior
I.D. (d)

Longitud de Proyección
Projection length (L)

Tipo de alta presión
High pressure type

Llave Inglesa
Spanner
Pág. 099



Tornillo de retención (para UTS) Stopper Bolt (for UTS)

BL

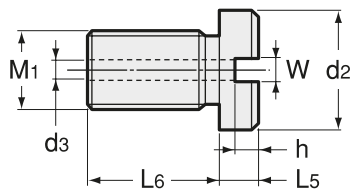

Código Code	Modelo Model	M1 P=1.0	L5	L6	W	h	d2	d3	Portaherramienta Chucks
0711 040016 ※※	BL 16 -L5	10	5, 15, 25	14	5	3.5	15	4.5	CT16 ~ 42

Elija la dimensión L5 correcta; para esto, revise la longitud mínima de inserción y la profundidad del D.I. del zanco.

Choose right L5 dimension by checking minimum insertion length and shank I.D. depth.

Ejemplo para Ordenar - Ordering Example

BL16 - 15

Medida L5
Size L5

High-Precision Collet Holder

- Adecuado para barrenado, rima y acabado en fresa.
- Suitable for drilling, reaming and finish endmilling.

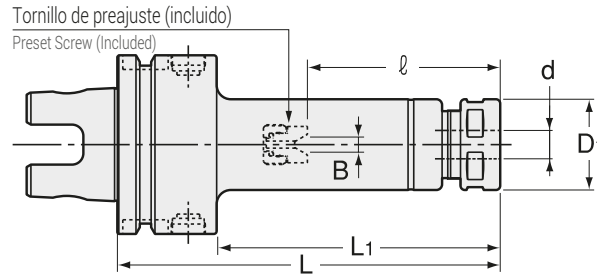

Unidad : Métrico
Unit : Metric

Código Code	Modelo Model	d	L	L1	B	ℓ	D1	Tuerca ciega Nut	kg	Boquilla Collet	Llave Inglesa Spanner
1260 11107075	UTS5040 -HDC07A -75-H	0.5 ~ 7.0	75	45	0 ~ 4	22 ~ 38	23	HDP-07A			
1260 11107090	-90-H	0.5 ~ 7.0	90	60	0 ~ 4	22 ~ 45	23	HDP-07A	0.6	FDC-07	S-0
1260 11107120	-120-H	0.5 ~ 7.0	120	90	0 ~ 4	22 ~ 45	23	HDP-07A	0.7		
1260 11109075	UTS5040 -HDC09A -75-H	2.5 ~ 9.0	75	45	0 ~ 4	27 ~ 31	26	HDP-09	0.7		
1260 11109090	-90-H	2.5 ~ 9.0	90	60	0 ~ 4	27 ~ 47	26	HDP-09	0.7	FDC-09	S-1L
1260 11109120	-120-H	2.5 ~ 9.0	120	90	0 ~ 4	27 ~ 61	26	HDP-09	0.8		
1260 11112090	UTS5040 -HDC12A -90-H	2.5 ~ 12.0	90	60	0 ~ 5	33 ~ 42	32	HDP-12	0.8		
1260 11112120	-120-H	2.5 ~ 12.0	120	90	0 ~ 5	33 ~ 69	32	HDP-12	0.9	FDC-12	S-3L
1260 11112150	-150-H	2.5 ~ 12.0	150	120	0 ~ 5	33 ~ 71	32	HDP-12			
1260 11116090	UTS5040 -HDC16A -90-H	3.5 ~ 16.0	90	60	0 ~ 6	38 ~ 50	36	HDP-16	0.8		
1260 11116120	-120-H	3.5 ~ 16.0	120	90	0 ~ 6	38 ~ 65	36	HDP-16	1.0	FDC-16	S-4L
1260 11116150	-150-H	3.5 ~ 16.0	150	120	0 ~ 6	38 ~ 82	36	HDP-16			
1260 11122090	UTS5040 -HDC22A -90-H	3.5 ~ 22.0	90	60	—	60	46	HDP-22			
1260 11122120	-120-H	3.5 ~ 22.0	120	90	0 ~ 8	47 ~ 63	46	HDP-22		FDC-22	S-5L
1260 11122150	-150-H	3.5 ~ 22.0	150	120	0 ~ 8	47 ~ 93	46	HDP-22			
1260 1 ※ 207075	UTS6350 -HDC07A -75	0.5 ~ 7.0	75	42	0 ~ 4	22 ~ 34	23	HDP-07A	1.0		
1260 1 ※ 207090	-90	0.5 ~ 7.0	90	57	0 ~ 4	22 ~ 45	23	HDP-07A	1.0	FDC-07	S-0
1260 1 ※ 207120	-120	0.5 ~ 7.0	120	87	0 ~ 4	22 ~ 45	23	HDP-07A	1.0		
1260 1 ※ 209075	UTS6350 -HDC09A -75	2.5 ~ 9.0	75	42	0 ~ 4	27 ~ 34	26	HDP-09			
1260 1 ※ 209090	-90	2.5 ~ 9.0	90	57	0 ~ 4	27 ~ 42	26	HDP-09	1.1	FDC-09	S-1L
1260 1 ※ 209120	-120	2.5 ~ 9.0	120	87	0 ~ 4	27 ~ 57	26	HDP-09	1.2		
1260 1 ※ 212090	UTS6350 -HDC12A -90	2.5 ~ 12.0	90	57	0 ~ 5	33 ~ 47	32	HDP-12	1.1		
1260 1 ※ 212120	-120	2.5 ~ 12.0	120	87	0 ~ 5	33 ~ 69	32	HDP-12	1.3	FDC-12	S-3L
1260 1 ※ 212150	-150	2.5 ~ 12.0	150	117	0 ~ 5	33 ~ 69	32	HDP-12	1.4		
1260 1 ※ 216090	UTS6350 -HDC16A -90	3.5 ~ 16.0	90	57	0 ~ 6	38 ~ 48	36	HDP-16	1.2		
1260 1 ※ 216120	-120	3.5 ~ 16.0	120	87	0 ~ 6	38 ~ 62	36	HDP-16	1.4	FDC-16	S-4L
1260 1 ※ 216150	-150	3.5 ~ 16.0	150	117	0 ~ 6	38 ~ 62	36	HDP-16	1.5		
1260 1 ※ 222090	UTS6350 -HDC22A -90	3.5 ~ 22.0	90	57	—	63	46	HDP-22	1.3		
1260 1 ※ 222120	-120	3.5 ~ 22.0	120	87	0 ~ 8	47 ~ 63	46	HDP-22	1.6	FDC-22	S-5L
1260 1 ※ 222150	-150	3.5 ~ 22.0	150	117	0 ~ 8	47 ~ 93	46	HDP-22	1.9		
1260 1 ※ 307075	UTS10080 -HDC07A -75	0.5 ~ 7.0	75	41	0 ~ 4	22 ~ 26	23	HDP-07A			
1260 1 ※ 307090	-90	0.5 ~ 7.0	90	56	0 ~ 4	22 ~ 45	23	HDP-07A		FDC-07	S-0
1260 1 ※ 307120	-120	0.5 ~ 7.0	120	86	0 ~ 4	22 ~ 45	23	HDP-07A			

Código Code	Modelo Model	d	L	L1	B	ℓ	D1	Tuerca ciega Nut	kg	Boquilla Collet	Llave Inglesa Spanner
1260 1 ※ 309075	UTS10080 -HDC09A -75	2.5 ~ 9.0	75	41	0 ~ 4	27 ~ 32	26	HDP-09		FDC-09	S-1L
1260 1 ※ 309090	-90	2.5 ~ 9.0	90	56	0 ~ 4	27 ~ 47	26	HDP-09			
1260 1 ※ 309120	-120	2.5 ~ 9.0	120	86	0 ~ 4	27 ~ 57	26	HDP-09			
1260 1 ※ 312090	UTS10080 -HDC12A -90	2.5 ~ 12.0	90	56	0 ~ 5	33 ~ 42	32	HDP-12		FDC-12	S-3L
1260 1 ※ 312120	-120	2.5 ~ 12.0	120	86	0 ~ 5	33 ~ 60	32	HDP-12	2.8		
1260 1 ※ 312150	-150	2.5 ~ 12.0	150	116	0 ~ 5	33 ~ 70	32	HDP-12			
1260 1 ※ 316090	UTS10080 -HDC16A -90	3.5 ~ 16.0	90	56	0 ~ 6	38 ~ 42	36	HDP-16		FDC-16	S-4L
1260 1 ※ 316120	-120	3.5 ~ 16.0	120	86	0 ~ 6	38 ~ 60	36	HDP-16	2.9		
1260 1 ※ 316150	-150	3.5 ~ 16.0	150	116	0 ~ 6	38 ~ 70	36	HDP-16			
1260 1 ※ 322090	UTS10080 -HDC22A -90	3.5 ~ 22.0	90	56	—	66	46	HDP-22		FDC-22	S-5L
1260 1 ※ 322120	-120	3.5 ~ 22.0	120	86	0 ~ 8	47 ~ 59	46	HDP-22	3.1		
1260 1 ※ 322150	-150	3.5 ~ 22.0	150	116	0 ~ 8	47 ~ 82	46	HDP-22	3.4		

Al hacer su orden, favor de especificar entre presión alta o baja. Para el tipo de presión alta, favor de agregar (-H) al final de la descripción.

1. La boquilla, llave inglesa, tornillo Allen opresor de preajuste y el tornillo de preajuste para procesos semisecos se venden por separado. El tornillo estándar de preajuste está incluido.
2. Consulte la pág. 096 para conocer la longitud mínima para insertar herramientas en caso de usar nuestras boquillas refrigerantes (OH, C o MS).
3. ℓ indica la dimensión al usarlo con un tornillo de preajuste.
4. El UTS5040 sólo está disponible en presión alta.
5. Consulte la pág. 520 para conocer el Torque recomendado en nuestros productos.

When placing an order, please specify high or low pressure. For high pressure type, please add (-H) on end of the description.

1. Collet, spanner, hexagon head preset screw, preset screw for semi-dry processing are sold separately. Standard preset screw is included.
2. Refer to P.096 for minimum tool insertion length in case of using our coolant collets (OH,C or MS).
3. ℓ indicates dimension when using with a preset screw.
4. UTS5040 is available in high pressure only.
5. See P.520 for standard Tightening Torque.

Boquilla Collet Pág. 090-093 	Llave Inglesa Spanner Pág. 099 	Tornillo de preajuste Preset screw Pág. 098 
---	---	--

Ejemplo para Ordenar - Ordering Example

Tipo de baja presión - Low pressure type
0 ~ 1.0MPa (UTS10080 : 0 ~ 2.0MPa)

UTS6350 - HDC 16 A - 120

Interfaz y diámetro de husillo

Shank size

Máx. Diámetro Interno de boquilla

Max. collet I.D.

Longitud de Proyección

Projection length (L)

Ejemplo para Ordenar - Ordering Example

Tipo de alta presión - High pressure type
1.1 ~ 7.0MPa (UTS10080 : 2.1 ~ 7.0MPa)

UTS6350 - HDC 16 A - 120 - H

Interfaz y diámetro de husillo

Shank size

Máx. Diámetro Interno de boquilla

Max. collet I.D.

Longitud de Proyección

Projection length (L)

Tipo de alta presión

High pressure type

Drill Holder With Easy Tool Length Adjustment

- La longitud de proyección de la herramienta de corte se puede ajustar simplemente girando la circunferencia del portaherramienta.
- Projection length of the cutting tool can be adjusted by simply turning circumference of the holder.

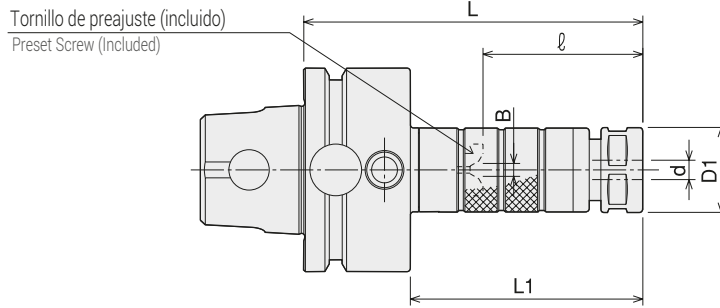

Unidad : Métrico
Unit : Metric

Código Code	Modelo Model	d	L	ℓ	L1	B	D1	Tuerca ciega Nut	Boquilla Collet	Llave Inglesa Spanner
1380 01107090	UTS5040 -SDM07 -90-H	0.5 ~ 7.0	90	29 ~ 39	60	0 ~ 4	23	HDP-07A	FDC-07	S-0
1380 01107105	-105-H	0.5 ~ 7.0	105	29 ~ 54	75	0 ~ 4	23	HDP-07A		
1380 01107120	-120-H	0.5 ~ 7.0	120	29 ~ 54	90	0 ~ 4	23	HDP-07A		
1380 01109090	UTS5040 -SDM09 -90-H	2.5 ~ 9.0	90	28 ~ 38	60	0 ~ 4	26	HDP-09	FDC-09	S-1L
1380 01109105	-105-H	2.5 ~ 9.0	105	28 ~ 53	75	0 ~ 4	26	HDP-09		
1380 01109120	-120-H	2.5 ~ 9.0	120	28 ~ 53	90	0 ~ 4	26	HDP-09		
1380 01112105	UTS5040 -SDM12 -105-H	2.5 ~ 12.0	105	34 ~ 44	75	0 ~ 5	32	HDP-12	FDC-12	S-3L
1380 01112120	-120-H	2.5 ~ 12.0	120	34 ~ 59	90	0 ~ 5	32	HDP-12		
1380 01112135	-135-H	2.5 ~ 12.0	135	34 ~ 59	105	0 ~ 5	32	HDP-12		
1380 01112150	-150-H	2.5 ~ 12.0	150	34 ~ 59	120	0 ~ 5	32	HDP-12		
1380 01116105	UTS5040 -SDM16 -105-H	3.5 ~ 16.0	105	40 ~ 50	75	0 ~ 6	36	HDP-16	FDC-16	S-4L
1380 01116120	-120-H	3.5 ~ 16.0	120	40 ~ 65	90	0 ~ 6	36	HDP-16		
1380 01116135	-135-H	3.5 ~ 16.0	135	40 ~ 65	105	0 ~ 6	36	HDP-16		
1380 01116150	-150-H	3.5 ~ 16.0	150	40 ~ 65	120	0 ~ 6	36	HDP-16		
1380 01122120	UTS5040 -SDM22 -120-H	3.5 ~ 22.0	120	48 ~ 58	90	0 ~ 8	46	HDP-22	FDC-22	S-5L
1380 01122135	-135-H	3.5 ~ 22.0	135	48 ~ 73	105	0 ~ 8	46	HDP-22		
1380 01122150	-150-H	3.5 ~ 22.0	150	48 ~ 73	120	0 ~ 8	46	HDP-22		
1380 0 ※ 207090	UTS6350 -SDM07 -90	0.5 ~ 7.0	90	29 ~ 39	57	0 ~ 4	23	HDP-07A	FDC-07	S-0
1380 0 ※ 207105	-105	0.5 ~ 7.0	105	29 ~ 54	72	0 ~ 4	23	HDP-07A		
1380 0 ※ 207120	-120	0.5 ~ 7.0	120	29 ~ 54	87	0 ~ 4	23	HDP-07A		
1380 0 ※ 207135	-135	0.5 ~ 7.0	135	29 ~ 54	102	0 ~ 4	23	HDP-07A		
1380 0 ※ 207150	-150	0.5 ~ 7.0	150	29 ~ 54	117	0 ~ 4	23	HDP-07A		
1380 0 ※ 209090	UTS6350 -SDM09 -90	2.5 ~ 9.0	90	28 ~ 38	57	0 ~ 4	26	HDP-09	FDC-09	S-1L
1380 0 ※ 209105	-105	2.5 ~ 9.0	105	28 ~ 53	72	0 ~ 4	26	HDP-09		
1380 0 ※ 209120	-120	2.5 ~ 9.0	120	28 ~ 53	87	0 ~ 4	26	HDP-09		
1380 0 ※ 209135	-135	2.5 ~ 9.0	135	28 ~ 53	102	0 ~ 4	26	HDP-09		
1380 0 ※ 209150	-150	2.5 ~ 9.0	150	28 ~ 53	117	0 ~ 4	26	HDP-09		
1380 0 ※ 209180	-180	2.5 ~ 9.0	180	28 ~ 53	147	0 ~ 4	26	HDP-09		
1380 0 ※ 212105	UTS6350 -SDM12 -105	2.5 ~ 12.0	105	34 ~ 44	72	0 ~ 5	32	HDP-12	FDC-12	S-3L
1380 0 ※ 212120	-120	2.5 ~ 12.0	120	34 ~ 59	87	0 ~ 5	32	HDP-12		
1380 0 ※ 212135	-135	2.5 ~ 12.0	135	34 ~ 59	102	0 ~ 5	32	HDP-12		
1380 0 ※ 212150	-150	2.5 ~ 12.0	150	34 ~ 59	117	0 ~ 5	32	HDP-12		
1380 0 ※ 212180	-180	2.5 ~ 12.0	180	34 ~ 59	147	0 ~ 5	32	HDP-12		
1380 0 ※ 216105	UTS6350 -SDM16 -105	3.5 ~ 16.0	105	40 ~ 50	72	0 ~ 6	36	HDP-16	FDC-16	S-4L
1380 0 ※ 216120	-120	3.5 ~ 16.0	120	40 ~ 65	87	0 ~ 6	36	HDP-16		
1380 0 ※ 216135	-135	3.5 ~ 16.0	135	40 ~ 65	102	0 ~ 6	36	HDP-16		
1380 0 ※ 216150	-150	3.5 ~ 16.0	150	40 ~ 65	117	0 ~ 6	36	HDP-16		
1380 0 ※ 216180	-180	3.5 ~ 16.0	180	40 ~ 65	147	0 ~ 6	36	HDP-16		
1380 0 ※ 222120	UTS6350 -SDM22 -120	3.5 ~ 22.0	120	48 ~ 58	87	0 ~ 8	46	HDP-22	FDC-22	S-5L
1380 0 ※ 222135	-135	3.5 ~ 22.0	135	48 ~ 73	102	0 ~ 8	46	HDP-22		
1380 0 ※ 222150	-150	3.5 ~ 22.0	150	48 ~ 73	117	0 ~ 8	46	HDP-22		
1380 0 ※ 222180	-180	3.5 ~ 22.0	180	48 ~ 73	147	0 ~ 8	46	HDP-22		

Código Code	Modelo Model	d	L	ℓ	L1	B	D1	Tuerca ciega Nut	Boquilla Collet	Llave Inglesa Spanner
1380 0 ※ 307090	UTS10080 -SDM07 -90	0.5 ~ 7.0	90	29 ~ 39	56	0 ~ 4	23	HDP-07A	FDC-07	S-0
1380 0 ※ 307105	-105	0.5 ~ 7.0	105	29 ~ 54	71	0 ~ 4	23	HDP-07A		
1380 0 ※ 307120	-120	0.5 ~ 7.0	120	29 ~ 54	86	0 ~ 4	23	HDP-07A		
1380 0 ※ 307135	-135	0.5 ~ 7.0	135	29 ~ 54	101	0 ~ 4	23	HDP-07A		
1380 0 ※ 307150	-150	0.5 ~ 7.0	150	29 ~ 54	116	0 ~ 4	23	HDP-07A		
1380 0 ※ 307165	-165	0.5 ~ 7.0	165	29 ~ 54	131	0 ~ 4	23	HDP-07A		
1380 0 ※ 309090	UTS10080 -SDM09 -90	2.5 ~ 9.0	90	28 ~ 38	56	0 ~ 4	26	HDP-09	FDC-09	S-1L
1380 0 ※ 309105	-105	2.5 ~ 9.0	105	28 ~ 53	71	0 ~ 4	26	HDP-09		
1380 0 ※ 309120	-120	2.5 ~ 9.0	120	28 ~ 53	86	0 ~ 4	26	HDP-09		
1380 0 ※ 309135	-135	2.5 ~ 9.0	135	28 ~ 53	101	0 ~ 4	26	HDP-09		
1380 0 ※ 309150	-150	2.5 ~ 9.0	150	28 ~ 53	116	0 ~ 4	26	HDP-09		
1380 0 ※ 309180	-180	2.5 ~ 9.0	180	28 ~ 53	146	0 ~ 4	26	HDP-09		
1380 0 ※ 312105	UTS10080 -SDM12 -105	2.5 ~ 12.0	105	34 ~ 44	71	0 ~ 5	32	HDP-12	FDC-12	S-3L
1380 0 ※ 312120	-120	2.5 ~ 12.0	120	34 ~ 59	86	0 ~ 5	32	HDP-12		
1380 0 ※ 312135	-135	2.5 ~ 12.0	135	34 ~ 59	101	0 ~ 5	32	HDP-12		
1380 0 ※ 312150	-150	2.5 ~ 12.0	150	34 ~ 59	116	0 ~ 5	32	HDP-12		
1380 0 ※ 312180	-180	2.5 ~ 12.0	180	34 ~ 59	146	0 ~ 5	32	HDP-12		
1380 0 ※ 316105	UTS10080 -SDM16 -105	3.5 ~ 16.0	105	40 ~ 50	71	0 ~ 6	36	HDP-16		
1380 0 ※ 316120	-120	3.5 ~ 16.0	120	40 ~ 65	86	0 ~ 6	36	HDP-16		
1380 0 ※ 316135	-135	3.5 ~ 16.0	135	40 ~ 65	101	0 ~ 6	36	HDP-16		
1380 0 ※ 316150	-150	3.5 ~ 16.0	150	40 ~ 65	116	0 ~ 6	36	HDP-16		
1380 0 ※ 316180	-180	3.5 ~ 16.0	180	40 ~ 65	146	0 ~ 6	36	HDP-16		
1380 0 ※ 322120	UTS10080 -SDM22 -120	3.5 ~ 22.0	120	48 ~ 58	86	0 ~ 8	46	HDP-22	FDC-22	S-5L
1380 0 ※ 322135	-135	3.5 ~ 22.0	135	48 ~ 73	101	0 ~ 8	46	HDP-22		
1380 0 ※ 322150	-150	3.5 ~ 22.0	150	48 ~ 73	116	0 ~ 8	46	HDP-22		
1380 0 ※ 322180	-180	3.5 ~ 22.0	180	48 ~ 73	146	0 ~ 8	46	HDP-22		
1380 0 ※ 322210	-210	3.5 ~ 22.0	210	48 ~ 73	176	0 ~ 8	46	HDP-22		

Al hacer su orden, favor de especificar entre presión alta o baja. Para el tipo de presión alta, favor de agregar (-H) al final de la descripción.

1. La boquilla y la llave inglesa se venden por separado.
2. ℓ es la dimensión entre el cabezal del pistón y el extremo superior del tornillo de preajuste.
3. El UTS5040 sólo está disponible en presión alta.
4. Consulte la pág. 520 para conocer el Torque recomendado en nuestros productos.

When placing an order, please specify high or low pressure. For high pressure type, please add (-H) on end of the description.

1. Collet and spanner are sold separately.
2. ℓ is the dimension between the cap end and the preset screw top end.
3. UTS5040 is available in high pressure only.
4. See P.520 for standard Tightening Torque.

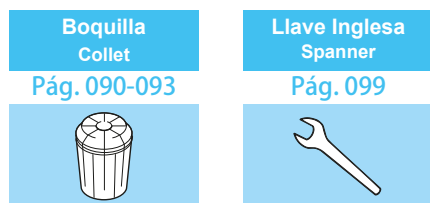

Ejemplo para Ordenar - Ordering Example

Tipo de baja presión - Low pressure type

0 ~ 1.0MPa (UTS10080 : 0 ~ 2.0MPa)

UTS6350 - SDM 12 - 105

Interfaz y diámetro de husillo

Shank size

Máx. Diámetro interno de boquilla

Max. collet I.D.

Longitud de Proyección

Projection length (L)

Ejemplo para Ordenar - Ordering Example

Tipo de alta presión - High pressure type

1.1 ~ 7.0MPa (UTS10080 : 2.1 ~ 7.0MPa)

UTS6350 - SDM 12 - 105 - H

Interfaz y diámetro de husillo

Shank size

Máx. Diámetro interno de boquilla

Max. collet I.D.

Longitud de Proyección

Projection length (L)

Tipo de alta presión

High pressure type

Collet Holder For Small Diameters

- Para barrenado en espacios reducidos.
- For drilling in tight space.

Tornillo de preajuste
 Portaherramienta ERC8: se vende por separado
 Portaherramientas con diferente diámetro a 8: incluido

Preset Screw
 ERC8 Holder : Sold separately
 Other Holder : Included

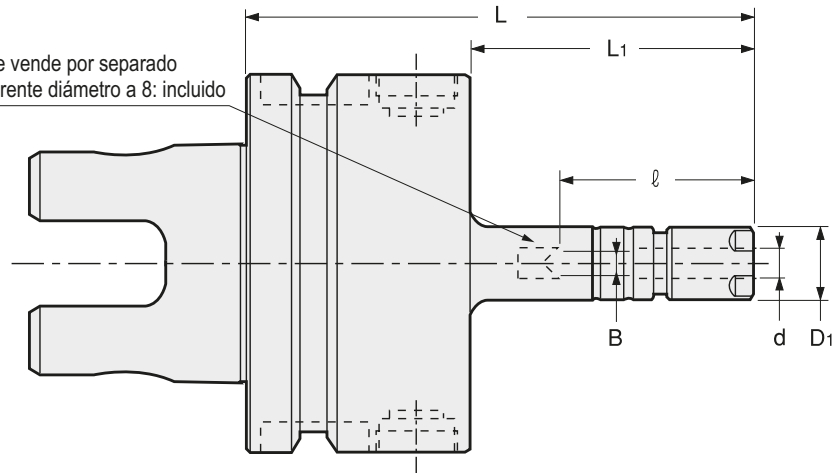

Unidad : Métrico
 Unit : Metric

Código Code	Modelo Model	d	L	L1	B	ℓ	D1	Tuerca ciega Nut	kg	Boquilla Collet	Llave Inglesa Spanner
1340 01108075	UTS5040 -ERC8 -75H	0.5 ~ 5.0	75	45	— (0 ~ 2.4)	³⁴ (19 ~ 24)	12	ERP-8	0.5	ER8	S-8E
1340 01108105	-105H	0.5 ~ 5.0	105	75	— (0 ~ 2.4)	³⁴ (19 ~ 31)	12	ERP-8	0.6		
1340 01110075	UTS5040 -ERC11S -75H	0.5 ~ 7.0	75	45	0 ~ 4	22 ~ 32	16	ERP-11S	0.6	ER11	S-11E
1340 01110105	-105H	0.5 ~ 7.0	105	75	0 ~ 4	22 ~ 45	16	ERP-11S	0.6		
1340 0 ※ 208075	UTS6350 -ERC8 -75	0.5 ~ 5.0	75	42	— (0 ~ 2.4)	³⁴ (19 ~ 24)	12	ERP-8	0.9	ER8	S-8E
1340 0 ※ 208105	-105	0.5 ~ 5.0	105	72	— (0 ~ 2.4)	³⁴ (19 ~ 31)	12	ERP-8	1.0		
1340 0 ※ 210075	UTS6350 -ERC11S -75	0.5 ~ 7.0	75	42	0 ~ 4	22 ~ 34	16	ERP-11S	1.0	ER11	S-11E
1340 0 ※ 210105	-105	0.5 ~ 7.0	105	72	0 ~ 4	22 ~ 45	16	ERP-11S	1.0		

Al hacer su orden, favor de especificar entre presión alta o baja. Para el tipo de presión alta, favor de agregar (-H) al final de la descripción.

1. La boquilla y la llave inglesa se venden por separado.
2. El ES8, un tornillo de preajuste para el ERC8, se vende por separado. El ERC11S incluye un tornillo estándar de preajuste HDS-07A-ES11.
3. Las dimensiones "B" e "ℓ" entre paréntesis sirven para usar el tornillo de preajuste ES8.
4. Consulte la pág. 096 para conocer la longitud mínima para insertar herramientas en caso de usar nuestras boquillas refrigerantes.
5. El UTS5040 sólo está disponible en presión alta.
6. Consulte la pág. 520 para conocer el Torque recomendado en nuestros productos.

Boquilla Collet Pág. 094-095 	Llave Inglesa Spanner Pág. 099 	Tornillo de preajuste Preset screw Pág. 098 
---	---	--

When placing an order, please specify high or low pressure. For high pressure type, please add (-H) on end of the description.

1. Collet and spanner are sold separately.
2. ES8, a preset screw for ERC8, is sold separately. ERC11S includes a standard preset screw HDS-07A-ES11.
3. "B" and "ℓ" dimensions in brackets are for using ES8 preset screw.
4. Refer to P.096 for minimum tool insertion length in case of using our coolant collets.
5. UTS5040 is available in high pressure only.
6. See P.520 for standard Tightening Torque.

Ejemplo para Ordenar - Ordering Example

Tipo de baja presión - Low pressure type

0 ~ 1.0MPa

UTS6350 - ERC 8 - 75

Interfaz y diámetro de husillo

Shank size

Máx. Diámetro Interno de boquilla

Max. collet I.D.

Longitud de Proyección

Projection length (L)

Ejemplo para Ordenar - Ordering Example

Tipo de alta presión - High pressure type

1.1 ~ 7.0MPa

UTS6350 - ERC 8 - 75 - H

Interfaz y diámetro de husillo

Shank size

Máx. Diámetro Interno de boquilla

Max. collet I.D.

Longitud de Proyección

Projection length (L)

Tipo de alta presión

High pressure type

ERC-T

Collet Holder For Small Diameters (Taper Type)

- Para barrenado en espacios reducidos.
- For drilling in tight space.

Tornillo de preajuste

Portaherramienta ERC8: se vende por separado
Portaherramientas con diferente diámetro a 8: incluido

Preset Screw

ERC8 Holder : Sold separately
Other Holder : Included

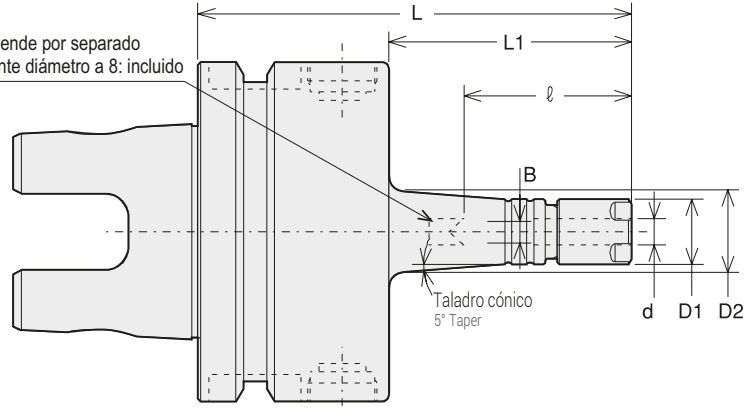

Unidad : Métrico
Unit : Metric

Código Code	Modelo Model	d	L	L1	B	ℓ	D1	D2	Tuerca ciega Nut	Boquilla Collet	Llave Inglesa Spanner
1340 11108075	UTS5040 -ERC8 -75TH	0.5 ~ 5.0	75	45	(0 ~ 2.4)	(19 ~ 24)	12	16	ERP-8	ER8	S-8E
1340 11108105	-105TH	0.5 ~ 5.0	105	75	(0 ~ 2.4)	(19 ~ 31)	12	21	ERP-8	ER8	S-8E
1340 11110075	UTS5040 -ERC11S -75TH	0.5 ~ 7.0	75	45	0 ~ 4	22 ~ 32	16	19.5	ERP-11S	ER11	S-11E
1340 11110105	-105TH	0.5 ~ 7.0	105	75	0 ~ 4	22 ~ 45	16	25	ERP-11S	ER11	S-11E
1340 1 ※ 208075	UTS6350 -ERC8 -75T	0.5 ~ 5.0	75	42	(0 ~ 2.4)	(19 ~ 24)	12	15.5	ERP-8	ER8	S-8E
1340 1 ※ 208105	-105T	0.5 ~ 5.0	105	72	(0 ~ 2.4)	(19 ~ 31)	12	20.5	ERP-8	ER8	S-8E
1340 1 ※ 210075	UTS6350 -ERC11S -75T	0.5 ~ 7.0	75	42	0 ~ 4	22 ~ 34	16	19	ERP-11S	ER11	S-11E
1340 1 ※ 210105	-105T	0.5 ~ 7.0	105	72	0 ~ 4	22 ~ 45	16	24.5	ERP-11S	ER11	S-11E

Al hacer su orden, favor de especificar entre presión alta o baja. Para el tipo de presión alta, favor de agregar (-H) al final de la descripción.

1. La boquilla y la llave inglesa se venden por separado.
2. El ES8, un tornillo de preajuste para el ERC8-T, se vende por separado. El ERC11S-T incluye un tornillo estándar de preajuste HDS-07A-ES11.
3. Las dimensiones "B" e "ℓ" entre corchetes sirven para usar el tornillo de preajuste ES8.
4. Consulte la pág. 096 para conocer la longitud mínima para insertar herramientas en caso de usar nuestras boquillas refrigerantes.
5. El UTS5040 sólo está disponible en presión alta.
6. Consulte la pág. 520 para conocer el Torque recomendado en nuestros productos.

Boquilla Collet
Pág. 094-095

Llave de Torque Spanner
Pág. 099

Tornillo de preajuste Preset screw
Pág. 098

When placing an order, please specify high or low pressure. For high pressure type, please add (-H) on end of the description.

1. Collet and spanner are sold separately.
2. ES8, a preset screw for ERC8-T, is sold separately. ERC11S-T includes a standard preset screw HDS-07A-ES11.
3. "B" and "ℓ" dimensions in brackets are for using ES8 preset screw.
4. Refer to P.096 for minimum tool insertion length in case of using our coolant collets.
5. UTS5040 is available in high pressure only.
6. See P.520 for standard Tightening Torque.

Ejemplo para Ordenar - Ordering Example

Tipo de baja presión - Low pressure type
0 ~ 1.0MPa

UTS6350 - ERC 8 - 105 T

Interfaz y diámetro de husillo
Shank size

Máx. Diámetro Interno de boquilla
Max. collet I.D.

Longitud de Proyección
Projection length (L)

Ejemplo para Ordenar - Ordering Example

Tipo de alta presión - High pressure type
1.1 ~ 7.0MPa

UTS6350 - ERC 8 - 105 T - H

Interfaz y diámetro de husillo
Shank size

Máx. Diámetro Interno de boquilla
Max. collet I.D.

Longitud de Proyección
Projection length (L)

Tipo de alta presión
High pressure type

"R" Zero Holder

- La precisión de excentricidad del borde de corte puede ajustarse hasta casi cero.
- Runout accuracy of the cutting edge can be adjusted as closely as to zero.

Tipo1
Type1

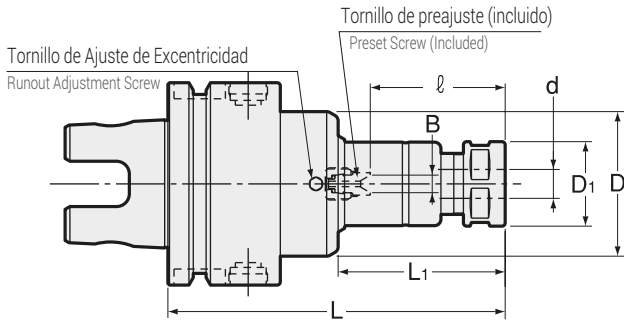

Tipo2
Type2

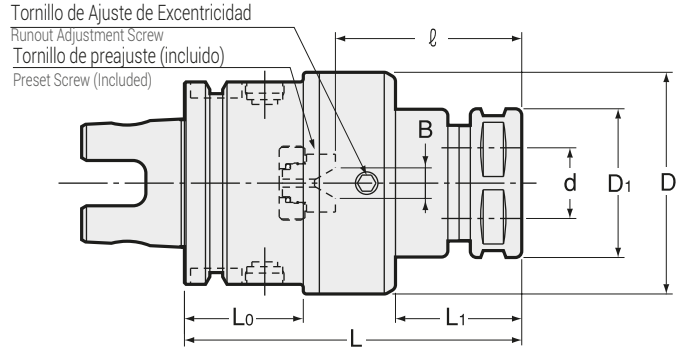

Unidad : Métrico
Unit : Metric

Código Code	Modelo Model	Tipo Type	d	L	ℓ	B	D	L1	L0	D1	Tuerca ciega Nut	kg	Boquilla Collet	Llave Inglesa Spanner	Llave Allen Hex. Wrench
1250 01107075	UTS5040 -HDZ07 -75-H	1	0.5 ~ 7.0	75	22 ~ 32	0 ~ 4	41	29	—	23	HDP-07A		FDC-07	S-0	L-3T
1250 01107090	-90-H	1	0.5 ~ 7.0	90	22 ~ 45	0 ~ 4	41	44	—	23	HDP-07A		FDC-07	S-0	L-3T
1250 01107120	-120-H	1	0.5 ~ 7.0	120	22 ~ 45	0 ~ 4	41	74	—	23	HDP-07A		FDC-07	S-0	L-3T
1250 01109075	UTS5040 -HDZ09 -75-H	1	2.5 ~ 9.0	75	27 ~ 31	0 ~ 4	41	29	—	26	HDP-09		FDC-09	S-1L	L-3T
1250 01109090	-90-H	1	2.5 ~ 9.0	90	27 ~ 47	0 ~ 4	41	44	—	26	HDP-09		FDC-09	S-1L	L-3T
1250 01109120	-120-H	1	2.5 ~ 9.0	120	27 ~ 61	0 ~ 4	41	74	—	26	HDP-09		FDC-09	S-1L	L-3T
1250 01112090	UTS5040 -HDZ12 -90-H	2	2.5 ~ 12.0	90	33 ~ 41	0 ~ 5	52	35	30	32	HDP-12		FDC-12	S-3L	L-4T
1250 01112120	-120-H	2	2.5 ~ 12.0	120	33 ~ 70	0 ~ 5	52	65	30	32	HDP-12		FDC-12	S-3L	L-4T
1250 01112150	-150-H	2	2.5 ~ 12.0	150	33 ~ 73	0 ~ 5	52	95	30	32	HDP-12		FDC-12	S-3L	L-4T
1250 01116090	UTS5040 -HDZ16 -90-H	2	3.5 ~ 16.0	90	38 ~ 49	0 ~ 6	56	35	30	36	HDP-16		FDC-16	S-4L	L-4T
1250 01116120	-120-H	2	3.5 ~ 16.0	120	38 ~ 64	0 ~ 6	56	65	30	36	HDP-16		FDC-16	S-4L	L-4T
1250 01116150	-150-H	2	3.5 ~ 16.0	150	38 ~ 85	0 ~ 6	56	95	30	36	HDP-16		FDC-16	S-4L	L-4T
1250 0 ※ 207075	UTS6350 -HDZ07 -75	1	0.5 ~ 7.0	75	22 ~ 34	0 ~ 4	41	26	—	23	HDP-07A		FDC-07	S-0	L-3T
1250 0 ※ 207090	-90	1	0.5 ~ 7.0	90	22 ~ 45	0 ~ 4	41	41	—	23	HDP-07A	1.1	FDC-07	S-0	L-3T
1250 0 ※ 207120	-120	1	0.5 ~ 7.0	120	22 ~ 45	0 ~ 4	41	71	—	23	HDP-07A	1.2	FDC-07	S-0	L-3T
1250 0 ※ 209075	UTS6350 -HDZ09 -75	1	2.5 ~ 9.0	75	27 ~ 34	0 ~ 4	45	26	—	26	HDP-09		FDC-09	S-1L	L-3T
1250 0 ※ 209090	-90	1	2.5 ~ 9.0	90	27 ~ 42	0 ~ 4	45	41	—	26	HDP-09	1.1	FDC-09	S-1L	L-3T
1250 0 ※ 209120	-120	1	2.5 ~ 9.0	120	27 ~ 57	0 ~ 4	45	71	—	26	HDP-09	1.3	FDC-09	S-1L	L-3T
1250 0 ※ 212090	UTS6350 -HDZ12 -90	1	2.5 ~ 12.0	90	33 ~ 47	0 ~ 5	52	37	—	32	HDP-12	1.3	FDC-12	S-3L	L-4T
1250 0 ※ 212120	-120	1	2.5 ~ 12.0	120	33 ~ 69	0 ~ 5	52	67	—	32	HDP-12		FDC-12	S-3L	L-4T
1250 0 ※ 212150	-150	1	2.5 ~ 12.0	150	33 ~ 69	0 ~ 5	52	97	—	32	HDP-12	1.6	FDC-12	S-3L	L-4T
1250 0 ※ 216090	UTS6350 -HDZ16 -90	1	3.5 ~ 16.0	90	38 ~ 47	0 ~ 6	56	37	33	36	HDP-16	1.3	FDC-16	S-4L	L-4T
1250 0 ※ 216120	-120	1	3.5 ~ 16.0	120	38 ~ 61	0 ~ 6	56	67	33	36	HDP-16	1.5	FDC-16	S-4L	L-4T
1250 0 ※ 216150	-150	1	3.5 ~ 16.0	150	38 ~ 61	0 ~ 6	56	97	33	36	HDP-16		FDC-16	S-4L	L-4T
1250 1 ※ 222120	UTS6350 -HDZ22-A-120	2	3.5 ~ 22.0	120	47 ~ 62	0 ~ 8	69	58	33	46	HDP-22	2.0	FDC-22	S-5L	L-5T
1250 1 ※ 222150	-150	2	3.5 ~ 22.0	150	47 ~ 92	0 ~ 8	69	88	33	46	HDP-22		FDC-22	S-5L	L-5T
1250 0 ※ 307075	UTS10080 -HDZ07 -75	1	0.5 ~ 7.0	75	22 ~ 26	0 ~ 4	41	25	—	23	HDP-07A		FDC-07	S-0	L-3T
1250 0 ※ 307090	-90	1	0.5 ~ 7.0	90	22 ~ 45	0 ~ 4	41	40	—	23	HDP-07A		FDC-07	S-0	L-3T
1250 0 ※ 307120	-120	1	0.5 ~ 7.0	120	22 ~ 45	0 ~ 4	41	70	—	23	HDP-07A		FDC-07	S-0	L-3T

Código Code	Modelo Model	Tipo Type	d	L	ℓ	B	D	L1	L0	D1	Tuerca ciega Nut	kg	Boquilla Collet	Llave Inglesa Spanner	Llave Allen Hex. Wrench
1250 0 ※ 309075	UTS10080 -HDZ09 -75	1	2.5 ~ 9.0	75	27	0 ~ 4	45	25	—	26	HDP-09				
1250 0 ※ 309090	-90	1	2.5 ~ 9.0	90	27 ~ 47	0 ~ 4	45	40	—	26	HDP-09		FDC-09	S-1L	L-3T
1250 0 ※ 309120	-120	1	2.5 ~ 9.0	120	27 ~ 57	0 ~ 4	45	70	—	26	HDP-09				
1250 0 ※ 312090	UTS10080 -HDZ12 -90	1	2.5 ~ 12.0	90	33 ~ 41	0 ~ 5	56	36	—	32	HDP-12				
1250 0 ※ 312120	-120	1	2.5 ~ 12.0	120	33 ~ 59	0 ~ 5	56	66	—	32	HDP-12		FDC-12	S-3L	L-4T
1250 0 ※ 312150	-150	1	2.5 ~ 12.0	150	33 ~ 69	0 ~ 5	56	96	—	32	HDP-12				
1250 0 ※ 316090	UTS10080 -HDZ16 -90	1	3.5 ~ 16.0	90	38 ~ 41	0 ~ 6	62	36	—	36	HDP-16				
1250 0 ※ 316120	-120	1	3.5 ~ 16.0	120	38 ~ 59	0 ~ 6	62	66	—	36	HDP-16		FDC-16	S-4L	L-4T
1250 0 ※ 316150	-150	1	3.5 ~ 16.0	150	38 ~ 69	0 ~ 6	62	96	—	36	HDP-16				
1250 1 ※ 322090	UTS10080-HDZ22-A-90	1	3.5 ~ 22.0	90	56	0 ~ 8	76	32	—	46	HDP-22				
1250 1 ※ 322120	-120	1	3.5 ~ 22.0	120	47 ~ 58	0 ~ 8	76	62	—	46	HDP-22		FDC-22	S-5L	L-5T
1250 1 ※ 322150	-150	1	3.5 ~ 22.0	150	47 ~ 82	0 ~ 8	76	92	—	46	HDP-22				

Al hacer su orden, favor de especificar entre presión alta o baja. Para el tipo de presión alta, favor de agregar (-H) al final de la descripción.

1. La boquilla, llave inglesa, tornillo Allen opresor de preajuste y el tornillo de preajuste para procesos semisecos se venden por separado. El tornillo estándar de preajuste está incluido.
2. Consulte la pág. 096 para conocer la longitud mínima para insertar herramientas en caso de usar nuestras boquillas refrigerantes (OH, C o MS).
3. ℓ indica la dimensión al usarlo con un tornillo de preajuste.
4. El UTS5040 sólo está disponible en presión alta.
5. Consulte la pág. 520 para conocer el Torque recomendado en nuestros productos.

When placing an order, please specify high or low pressure. For high pressure type, please add (-H) on end of the description.

1. Collet, spanner, hexagon head preset screw, preset screw for semi-dry processing are sold separately. Standard preset screw is included.
2. Refer to P.096 for minimum tool insertion length in case of using our coolant collets (OH,C or MS).
3. ℓ indicates dimension when using with a preset screw.
4. UTS5040 is available in high pressure only.
5. See P.520 for standard Tightening Torque.

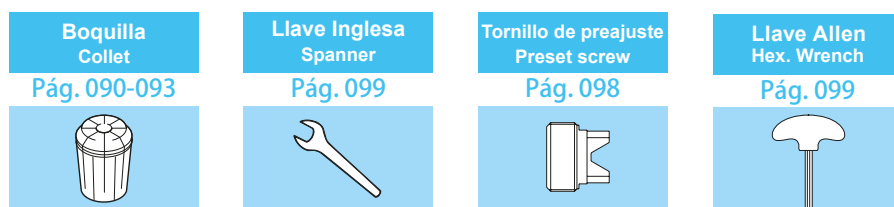

Ejemplo para Ordenar - Ordering Example

Tipo de baja presión - Low pressure type
0 ~ 1.0MPa (UTS10080 : 0 ~ 2.0MPa)

UTS6350 - HDZ 12 - 90

Interfaz y diámetro de husillo Shank size	Máx. Diámetro Interno de boquilla Max. collet I.D.	Longitud de Proyección Projection length (L)
--	---	---

Ejemplo para Ordenar - Ordering Example

Tipo de alta presión - High pressure type
1.1 ~ 7.0MPa (UTS10080 : 2.1 ~ 7.0MPa)

UTS6350 - HDZ 12 - 90 - H

Interfaz y diámetro de husillo Shank size	Máx. Diámetro Interno de boquilla Max. collet I.D.	Longitud de Proyección Projection length (L)	Tipo de alta presión High pressure type
--	---	---	--

CTZ-SA

"R" Zero Holder for Large Diameter

- La excentricidad del borde de corte se puede ajustar hasta casi cero. Es adecuado para rima con diámetro amplio.
- Runout of the cutting edge can be adjusted as close as to zero. Suitable for large diameter reaming.

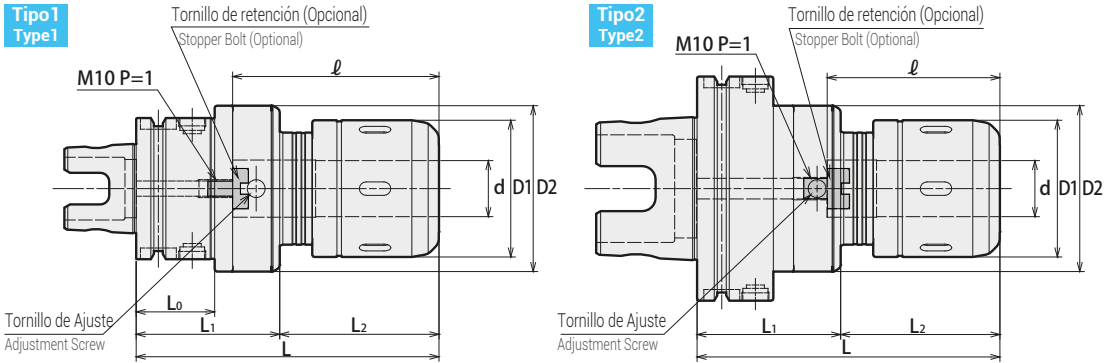

Precaución / Caution

Favor de girar el anillo de sujeción en sentido contrario a las manecillas del reloj por más de 360 grados después de quitar una herramienta de corte. Please rotate the clamping ring counterclockwise more than 360 degrees after a cutting tool is removed.

Medidas Métricas - Metric Sizes

Unidad : Métrico
Unit : Metric

Código Code	Modelo Model	Tipo Type	d	L	L1	L2	D1	D2	L0	ℓ	G P=1.0	kg	Max. min ⁻¹	-	Llave Inglesa Spanner	Llave Allen Hex. Wrench
1730 4 ※ 225135	UTS6350 -CTZ25SA -135	1	25	135	64	71	61	74	35	80	10	2.9	12,000	69,500	HS-2.5-25	L-6L (Incluida / Included)
1730 4 ※ 225150	-150	1	25	150	64	86	61	74	35	80	10	3.1	12,000	70,000		
1730 4 ※ 232135	-CTZ32SA -135 * 1	1	32	135	64	71	68	80	35	105	10	3.0	10,000	72,000	HS-3-32	
1730 4 ※ 232150	-150 * 1	1	32	150	64	86	68	80	35	120	10	3.2	10,000	75,000		
1730 4 ※ 325135	UTS10080 -CTZ25SA -135	2	25	135	64	71	61	74	-	80	10	4.4	12,500	80,500	HS-2.5-25	
1730 4 ※ 325150	-150	2	25	150	64	86	61	74	-	80	10	4.6	12,500	83,000		
1730 4 ※ 332135	-CTZ32SA -135 * 1	2	32	135	64	71	68	80	-	100	10	4.5	12,000	85,000	HS-3-32	
1730 4 ※ 332150	-150 * 1	2	32	150	64	86	68	80	-	115	10	4.8	12,000	88,000		
1730 4 ※ 342135	-CTZ42SA -135 * 2	2	42	135	65	70	88	99	-	100	10	5.9	10,000	96,000	HS-4-42	
1730 4 ※ 342150	-150 * 2	2	42	150	65	85	88	99	-	110	10	6.1	10,000	99,000		

Favor de reemplazar ※ en el código con Ø para el tipo de baja presión y con 1 para el tipo de alta presión.

- Al hacer su orden, indique el número de llaves inglesas que requiere. Las llaves inglesas "son gratuitas" y están limitadas al número de portaherramientas de fresado de su orden.
- La llave Allen está incluida.
- El modelo con " * 1 - * 3" no es compatible con algunos accesorios. Para obtener más información sobre los accesorios, dirijase a la tabla a continuación.
- La tolerancia del zanco de las herramientas de corte debe ser de h7.

Please replace ※ in the code with Ø for low pressure type and 1 for high pressure type.

- When ordering, indicate number of spanners required. "No charge" spanners are limited to number of holders on order.
- A wrench is included.
- The model with " * 1" and " * 2" are not compatible with some accessories. For more information about the accessories, please refer below chart.
- Tolerance of cutting tool shank must be h7.

Llave Inglesa Spanner

Pág. 073



Accesorios Accessories

Los modelos con * 1 - * 2 no pueden usarse con algunos accesorios debido a la corta ℓ longitud. Models with * 1 - * 2 cannot be used with some accessories due to short ℓ length.

	Tornillo de retención Stopper Bolt BL (Pág.72)	Boquilla recta Straight Collet MC (Pág.070) MCA (Pág.071)	Adaptador Morse Morse Taper Adapter MA (Pág.072) MAB (Pág.072)	Adaptador Jacobs Jacobs Adapter JA (Pág.073) JAB (Pág.073)
* 1	BL16 únicamente / only	Sí / Yes	Sí / Yes	Sí / Yes
* 2	BL16 únicamente / only	Sí / Yes	No	No

Ejemplo para Ordenar - Ordering Example

Tipo de baja presión - Low pressure type

0 ~ 1.0MPa (UTS10080 : 0 ~ 2.0MPa)

UTS6350 - CTZ 32 SA - 135

Interfaz y diámetro de husillo Shank size	Diámetro Interno I.D. (d)	Longitud de Proyección Projection length (L)
--	------------------------------	---

Ejemplo para Ordenar - Ordering Example

Tipo de alta presión - High pressure type

1.1 ~ 7.0MPa (UTS10080 : 2.1 ~ 7.0MPa)

UTS6350 - CTZ 32 SA - 135 - H

Interfaz y diámetro de husillo Shank size	Diámetro Interno I.D. (d)	Longitud de Proyección Projection length (L)	Tipo de alta presión High pressure type
--	------------------------------	---	--

Longitud mín de inserción Min. chucking length

Fresado directo (sin boquilla MC)
Direct Chucking (without MC Collet)

D.I. de la boquilla Collet I.D.	Longitud mín de inserción Min. chucking length
25,32,42	50

Con boquilla MC / With MC collet

D.I. de la boquilla Collet I.D.	Longitud mín de inserción Min. chucking length	
	MC	MC-C, MC-OH
6,8	30	30
10,12	40	40
16,20	45	45
25	50	50
32	50	60

"R" Zero Holder For Small Diameters

- Portaherramienta con mecanismo de ajuste de excentricidad. Adecuado para barrenado en espacio angostos.
- Holder with runout adjustment mechanism. Suitable for drilling in tight space.

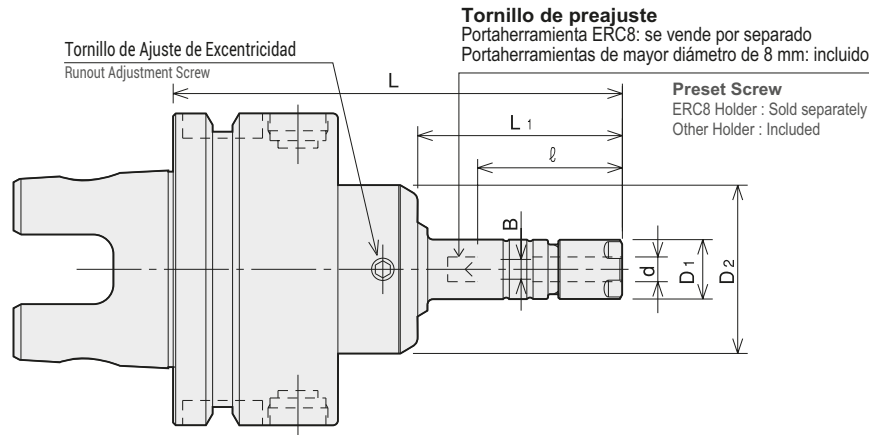

Unidad : Métrico
Unit : Metric

Código Code	Modelo Model	d	L	L1	B	ℓ	D1	D2	Tuerca ciega Nut	Boquilla Collet	Llave Inglesa Spanner	Llave Allen Hex. Wrench
1350 01108075	UTS5040 -ERZ8 -75H	0.5 ~ 5.0	75	29	— (0 ~ 3.1)	³³ (19 ~ 22)	12	34	ERP-8			
1350 01108090	-90H	0.5 ~ 5.0	90	44	— (0 ~ 3.1)	³³ (19 ~ 29)	12	34	ERP-8	ER8	S-8E	L-3T
1350 01108105	-105H	0.5 ~ 5.0	105	59	— (0 ~ 3.1)	³³ (19 ~ 29)	12	34	ERP-8			
1350 01110075	UTS5040 -ERZ11S-75H	0.5 ~ 7.0	75	29	0 ~ 4	22 ~ 29	16	34	ERP-11S			
1350 01110090	-90H	0.5 ~ 7.0	90	44	0 ~ 4	22 ~ 42	16	34	ERP-11S	ER11	S-11E	L-3T
1350 01110105	-105H	0.5 ~ 7.0	105	59	0 ~ 4	22 ~ 42	16	34	ERP-11S			
1350 0 ※ 208075	UTS6350 -ERZ8 -75	0.5 ~ 5.0	75	26	— (0 ~ 3.1)	³³ (19 ~ 22)	12	34	ERP-8			
1350 0 ※ 208090	-90	0.5 ~ 5.0	90	41	— (0 ~ 3.1)	³³ (19 ~ 29)	12	34	ERP-8	ER8	S-8E	L-3T
1350 0 ※ 208120	-120	0.5 ~ 5.0	120	71	— (0 ~ 3.1)	³³ (19 ~ 29)	12	34	ERP-8			
1350 0 ※ 210075	UTS6350 -ERZ11S-75	0.5 ~ 7.0	75	26	0 ~ 4	22 ~ 31	16	34	ERP-11S			
1350 0 ※ 210090	-90	0.5 ~ 7.0	90	41	0 ~ 4	22 ~ 42	16	34	ERP-11S	ER11	S-11E	L-3T
1350 0 ※ 210120	-120	0.5 ~ 7.0	120	71	0 ~ 4	22 ~ 42	16	34	ERP-11S			

Al hacer su orden, favor de especificar entre presión alta o baja. Para el tipo de presión alta, favor de agregar (-H) al final de la descripción.

1. La boquilla, el tornillo Allen opresor de preajuste, la llave Allen y la llave de torque se venden por separado.
2. El ES8, un tornillo de preajuste para el ERZ8, se vende por separado.
El ERZ11S incluye un tornillo estándar de preajuste HDS-07A-ES11.
3. Las dimensiones "B" y "ℓ" entre paréntesis son para usar el tornillo de preajuste ES8.
4. Consulte la pág. 096 para conocer la longitud mínima para insertar herramientas en caso de usar nuestras boquillas refrigerantes.
5. El UTS5040 sólo está disponible en presión alta.

Boquilla Collet Pág. 094-095 	Llave Inglesa Spanner Pág. 099 	Tornillo de preajuste Preset screw Pág. 098 	Llave Allen Hex. Wrench Pág. 099
--	--	---	--

When placing an order, please specify high or low pressure. For high pressure type, please add (-H) on end of the description.

1. Collet, spanner and adjustment wrench are sold separately.
2. ES8, a preset screw for ERZ8, is sold separately.
ERZ11S includes a standard preset screw HDS-07A-ES11.
3. "B" and "ℓ" dimensions in brackets are for using ES8 preset screw.
4. Refer to P.096 for minimum tool insertion length in case of using our coolant collets.
5. UTS5040 is available in high pressure only.

Ejemplo para Ordenar - Ordering Example

Tipo de baja presión - Low pressure type
0 ~ 1.0MPa

UTS6350 - ERZ 8 - 75
Interfaz y diámetro de husillo / Shank size Máx. Diámetro Interno de boquilla / Max. collet I.D. Longitud de Proyección / Projection length (L)

Ejemplo para Ordenar - Ordering Example

Tipo de alta presión - High pressure type
1.1 ~ 7.0MPa

UTS6350 - ERZ 8 - 75 - H
Interfaz y diámetro de husillo / Shank size Máx. Diámetro Interno de boquilla / Max. collet I.D. Longitud de Proyección / Projection length (L) Tipo de alta presión / High pressure type

PHC-A



Power Hydro Chuck

- Hydro Chuck con capacidad para boquillas. Adecuado para herramientas de corte de alta precisión.
- Hydro chuck with collet holder flexibility. Suitable for high precision cutting.

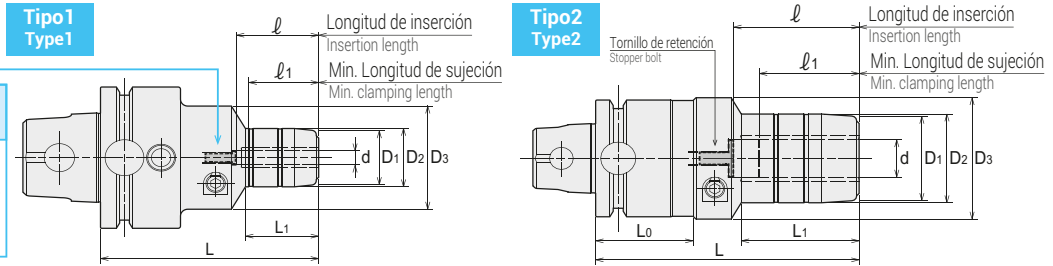

**Tornillo de retención
Stopper bolt**

Para PHC03A & PHC04A, El tornillo de retención no está incluido. Favor de ordenarlo por separado (producto especial).
For PHC03A & PHC04A, the stopper bolt is not included. Please order separately (Special item).

Código Code	Modelo Model	Tipo Type	d	L	L ₁	D ₁	D ₂	D ₃	L ₀	ℓ	ℓ ₁	Max. min ⁻¹	Kg	Llave Allen (Opcional) Hex. Wrench (Optional)	
1390 11103070	UTS5040 -PHC03A - 70-H	1	3	70	19.8	—	24	46	—	27	18	25,000	0.8	L-4T (4mm)	
1390 11104075	-PHC04A - 75-H	1	4	75	25.1	—	25	46	—	29	24	25,000	0.8		
1390 11106090	-PHC06A - 90-H	1	6	90	30	24	26	46	—	34	29	25,000	1.0		
1390 11107090	-PHC07A - 90-H	1	7	90	30	26	28	46	—	34	29	25,000	1.0		
1390 11108090	-PHC08A - 90-H	1	8	90	30	26	28	46	—	34	29	25,000	1.0		
1390 11109105	-PHC09A - 105-H	2	9	105	44	28	30	52	38	50	40	24,000	1.1		
1390 11110105	-PHC10A - 105-H	2	10	105	44	28	30	52	38	50	40	23,000	1.1		
1390 11111105	-PHC11A - 105-H	2	11	105	45	30	32	52	38	50	40	23,000	1.1		
1390 11112105	-PHC12A - 105-H*	2	12	105	45	30	32	52	38	50	40	23,000	1.1		
1390 11113105	-PHC13A - 105-H	2	13	105	46	34	36	52	38	50	40	22,000	1.2		
1390 11114105	-PHC14A - 105-H	2	14	105	46	34	36	52	38	50	40	22,000	1.2		
1390 11115105	-PHC15A - 105-H	2	15	105	46	36	38	52	38	50	40	21,000	1.2		
1390 111161 05	-PHC16A - 105-H	2	16	105	46	36	38	52	38	50	40	20,000	1.2		
1390 11120105	-PHC20A - 105-H*	1	20	105	49	40	42	46	—	50	40	19,000	1.2		
1390 1※203075	UTS6350 -PHC03A - 75	1	3	75	19.8	—	24	46	—	27	18	20,000	1.2		L-4T (4mm)
1390 1※204080	-PHC04A - 80	1	4	80	25.1	—	25	46	—	29	24	20,000	1.2		
1390 1※206090	-PHC06A - 90	1	6	90	30	24	26	46	—	34	29	20,000	1.3		
1390 1※207090	-PHC07A - 90	1	7	90	30	26	28	46	—	34	29	20,000	1.3		
1390 1※208090	-PHC08A - 90	1	8	90	30	26	28	46	—	34	29	20,000	1.3		
1390 1※209105	-PHC09A - 105	1	9	105	44	28	30	52	—	50	40	20,000	1.5		
1390 1※210105	-PHC10A - 105	1	10	105	44	28	30	52	—	50	40	20,000	1.5		
1390 1※211105	-PHC11A - 105	1	11	105	45	30	32	52	—	50	40	20,000	1.5		
1390 1※212105	-PHC12A - 105*	1	12	105	45	30	32	52	—	50	40	20,000	1.5		
1390 1※213105	-PHC13A - 105	1	13	105	46	34	36	52	—	50	40	20,000	1.5		
1390 1※214105	-PHC14A - 105	1	14	105	46	34	36	52	—	50	40	20,000	1.5		
1390 1※215105	-PHC15A - 105	1	15	105	46	36	38	52	—	50	40	20,000	1.6		
1390 1※216105	-PHC16A - 105	1	16	105	46	36	38	52	—	50	40	20,000	1.6		
1390 1※220105	-PHC20A - 105*	1	20	105	49	40	42	46	—	50	40	20,000	1.5		
1390 1※225120	-PHC25A - 120	1	25	120	59	50	52	59	—	60	50	16,000	2.1	L-6T (6mm)	

En el código del producto reemplazar ※ por Ø si desea agregar el tipo de presión baja, o por 1 si desea el tipo de presión alta.

- El zanco de la herramienta de corte debe estar dentro de la tolerancia especificada a continuación; Diámetro del zanco menor de 6 mm : Dentro de tolerancia h6. Diámetro del zanco de 6 mm o mayor : Dentro de la tolerancia h7. Tolerancia h6 ó 0/-0.01 es la tolerancia recomendada en las herramientas de corte al usar nuestros productos.
- PHC12A y PHC20A cuentan con orificios de acople para perno, para las boquillas que tienen incluido el balín de retención.
- El tipo de presión alta solo esta disponible para UTS5040.
- La velocidad permitida se ve afectada por la rigidez del husillo de la máquina y el balance de la herramienta de corte. Incrementar gradualmente de una velocidad lenta, hasta llegar a la velocidad adecuada.
- * Es posible utilizar boquillas PHS.

On the product code replace ※ for Ø if you wish to add low pressure type, or for 1 if you want high pressure type

- Cutting tool shank must be within tolerances specified below ;
Shank diameter less than 6mm : Within h6 tolerance
Shank diameter 6mm and over : Within h7 tolerance
h6 or 0/-0.01 tolerance is recommended when newly making a cutting tool.
- PHC12A and PHC20A have pin holes for collet with stopper pin on its body.
- Only high pressure type is available for UTS5040.
- Allowed speed is greatly affected by the stiffness of the machine spindle and the balance of the cutting tool. Gradually increase from a low speed, and use at the proper speed.
- * Compatible for PHS collet use.

Ejemplo para Ordenar - Ordering Example

Tipo de baja presión - Low pressure type
0 ~ 1.0MPa

UTS6350 - PHC 12 A - 105

Interfaz y diámetro de husillo
Shank size

Diámetro Interno
I.D.

Longitud de proyección
Projection length

Ejemplo para Ordenar - Ordering Example

Tipo de alta presión - High pressure type
1.1 ~ 7.0MPa

UTS6350 - PHC 12 A - 105 - H

Interfaz y diámetro de husillo
Shank size

Diámetro Interior
I.D.

Longitud de proyección
Projection length

Tipo de alta presión
High pressure type

**Boquilla PHS
PHS Collet**

Pág. 114

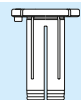

**Llave Allen
Hex. Wrench**

Pág. 99



PHC · SA-C Nuevo

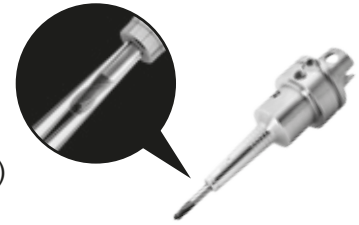

Portaherramienta Hidráulico Delgado "Blaster" (Para refrigeración por los costados)

Slim Hydro Chuck Blaster (For side through coolant)

- La opción perfecta para trabajos en espacios reducidos, tal como acabados en fresado, barrenado y rimado en máquinas de 5-ejes.
- Perfect choice for tight space applications, such as endmill finishing, drilling and reaming on 5-axis machines.

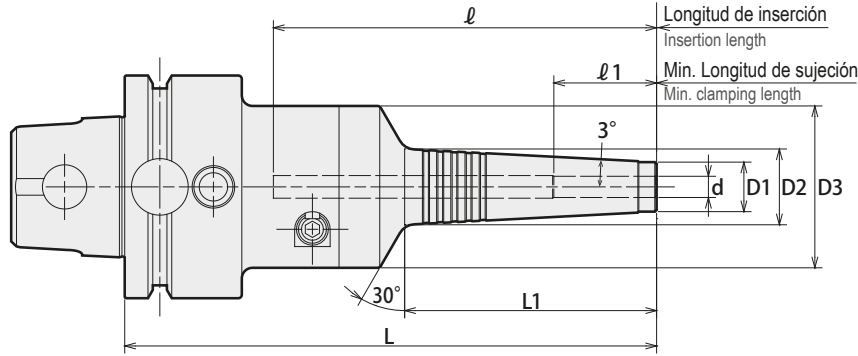

Código Code	Modelo Model	d	L	L1	D1	D2	D3	ℓ	ℓ1	min ⁻¹	kg	Llave Allen (Opcional) Wrench (Option)
1460 11103090	UTS5040 -PHC03SA -90 -C -H	3	90	30	12	15.2	46	78	18	25,000	0.7	L-4T
1460 11103135	-135 -C -H	3	135	71	12	19.5	46	123	18	21,000	1.0	
1460 11104090	-PHC04SA -90 -C -H	4	90	30	12	15.2	46	78	24	25,000	0.7	
1460 11104135	-135 -C -H	4	135	71	12	19.5	46	123	24	21,000	1.0	
1460 11106090	-PHC06SA -90 -C -H	6	90	26	14	16.8	46	53	29	25,000	1.0	
1460 11106150	-150 -C -H	6	150	87	14	23.2	46	113	29	20,000	1.2	
1460 11108090	-PHC08SA -90 -C -H	8	90	27	16	18.9	46	53	29	24,000	1.1	
1460 11108150	-150 -C -H	8	150	87	16	25.2	46	113	29	19,000	1.2	
1460 11110105	-PHC10SA -105 -C -H	10	105	42	18	22.5	46	68	40	23,000	1.1	
1460 11110150	-150 -C -H	10	150	87	18	27.3	46	113	40	19,000	1.2	
1460 11112105	-PHC12SA -105 -C -H	12	105	43	20	24.6	46	68	40	22,000	1.1	
1460 11112150	-150 -C -H	12	150	88	20	29.3	46	113	40	18,000	1.2	
1460 1※203100	UTS6350 -PHC03SA -100 -C	3	100	30	12	15.2	46	71	18	20,000	1.1	
1460 1※203145	-145 -C	3	145	71	12	19.5	46	116	18	20,000	1.4	
1460 1※204100	-PHC04SA -100 -C	4	100	30	12	15.2	46	71	24	20,000	1.1	
1460 1※204145	-145 -C	4	145	71	12	19.5	46	116	24	19,000	1.4	
1460 1※206105	-PHC06SA -105 -C	6	105	26	14	16.8	46	78	29	20,000	1.4	
1460 1※206150	-150 -C	6	150	71	14	21.5	46	123	29	20,000	1.5	
1460 1※208105	-PHC08SA -105 -C	8	105	27	16	18.9	46	78	29	20,000	1.5	
1460 1※208150	-150 -C	8	150	72	16	23.6	46	123	29	20,000	1.5	
1460 1※210120	-PHC10SA -120 -C	10	120	42	18	22.5	46	93	40	20,000	1.5	
1460 1※210150	-150 -C	10	150	72	18	25.6	46	123	40	20,000	1.6	
1460 1※212120	-PHC12SA -120 -C	12	120	43	20	24.6	46	93	40	20,000	1.5	
1460 1※212150	-150 -C	12	150	73	20	27.7	46	123	40	19,000	1.6	
1460 1※216150	-PHC16SA -150 -C	16	150	72	24	31.6	52.5	90	40	18,000	1.6	
1460 1※216180	-180 -C	16	180	103	24	34.8	52.5	120	40	12,000	1.8	
1460 1※220150	-PHC20SA -150 -C	20	150	63	29	35.7	62	85	40	18,000	2.1	
1460 1※220195	-195 -C	20	195	109	29	40.5	62	130	40	12,000	2.4	
1460 1※225150	-PHC25SA -150 -C	25	150	65	38	44.9	62	85	50	16,000	2.1	
1460 1※225195	-195 -C	25	195	112	38	49.8	62	130	50	12,000	2.6	

En el código del producto remplace ※ por Ø si desea ordenar el tipo de baja presión, o, por 1 si desea ordenar el tipo de alta presión.

1. La tolerancia del diámetro del zanco de la herramienta debe estar dentro de h6.
2. El UTS5040 sólo está disponible en presión alta.
3. La velocidad permitida varía mucho según la rigidez del husillo en la máquina y del balance de la herramienta de corte. Aumente gradualmente la velocidad a partir de la baja y úselo en la velocidad adecuada.

On the product code replace ※ for Ø if you wish to add low pressure type, or, for 1 if you want high pressure type.

1. Tool shank diameter tolerance must be within h6.
2. Only high pressure type is available for UTS5040.
3. Permissible speed is greatly affected by the stiffness of the machine spindle and the balance of the cutting tool. Gradually increase from a low speed, and use at the proper speed.

Ejemplo para Ordenar - Ordering Example

Tipo de baja presión - Low pressure type

0~1.0MPa

UTS6350 -PHC 16 SA- 150 -C

Interfaz y diámetro de husillo
Shank size

Diámetro Interior
I.D.

Longitud de proyección
Projection length

Ejemplo para Ordenar - Ordering Example

Tipo de alta presión - High pressure type

1.1~7.0MPa

UTS6350 -PHC 16 SA- 150 -C - H

Interfaz y diámetro de husillo
Shank size

Diámetro Interior
I.D.

Longitud de proyección
Projection length

Tipo de alta presión
High pressure type

Pulgada a métrico → Pulgada × 25.4

Métrico a pulgada → Métrico ÷ 25.4 ó métrico por 0.03937



Tamaños especiales / personalizados bajo pedido

UTS

BT

CAT

AHO

HSK-A/E/F/C

HSK-T

C

UTS

Máquinas Especializadas

Specialized Machine

Equipo Relacionado

Related Equipment

Taladro de Biselado & de Casquillo

Bush & Chamfering Drill

Milling Chuck

Collet Holder

"R" Zero Holder

Hydraulic Chuck

Shrink Fit

Tapping Chuck

Arbors



Portaherramienta Hidráulico Delgado

Slim Hydro Chuck

- La opción perfecta para trabajos en espacios reducidos, tales como acabados en fresado, barrenado y rimado en máquinas de 5-ejes.
- Perfect choice for tight space applications, such as endmill finishing, drilling and reaming on 5-axis machines.

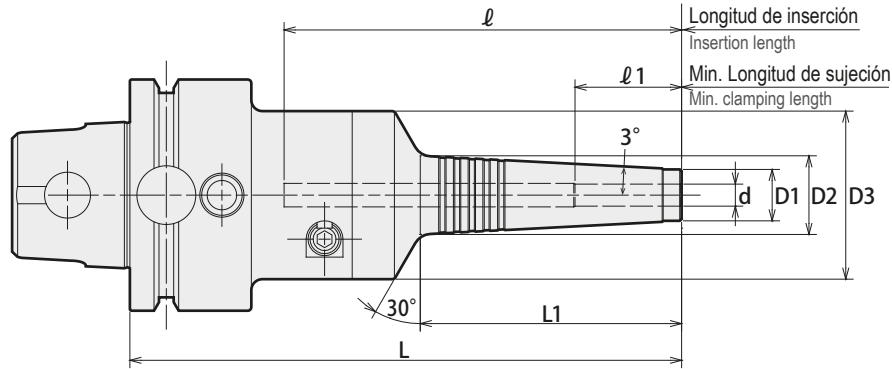

Código Code	Modelo Model	d	L	L1	D1	D2	D3	ℓ	ℓ1	min ⁻¹	Kg	Llave Allen (Opcional) Wrench(Option)
1490 11103080	UTS5040 -PHC03SA -80 -H	3	80	19	11	13.0	46	53	18	25,000	0.7	L-4T
1490 11103090	-90 -H	3	90	30	11	14.2	46	78	18	25,000	0.7	
1490 11103135	-135 -H	3	135	71	11	18.5	46	123	18	21,000	1.0	
1490 11104080	-PHC04SA -80 -H	4	80	19	11	13.0	46	68	24	25,000	0.7	
1490 11104090	-90 -H	4	90	30	11	14.2	46	78	24	25,000	0.7	
1490 11104135	-135 -H	4	135	71	11	18.5	46	123	24	21,000	1.0	
1490 11106090	-PHC06SA -90 -H	6	90	26	13	15.8	46	53	29	25,000	1.0	
1490 11106150	-150 -H	6	150	87	13	22.2	46	113	29	20,000	1.2	
1490 11106165	-165 -H	6	165	102	13	23.7	46	128	29	15,000	1.2	
1490 11106180	-180 -H	6	180	118	13	25.4	46	143	29	12,000	1.3	
1490 11107090	-PHC07SA -90 -H	7	90	26	14	16.8	46	53	29	24,000	1.1	
1490 11107150	-150 -H	7	150	87	14	23.2	46	113	29	20,000	1.2	
1490 11107165	-165 -H	7	165	102	14	24.7	46	128	29	15,000	1.2	
1490 11107180	-180 -H	7	180	118	14	26.2	46	143	29	12,000	1.3	
1490 11108090	-PHC08SA -90 -H	8	90	27	15	17.9	46	53	29	24,000	1.1	
1490 11108150	-150 -H	8	150	87	15	24.2	46	113	29	19,000	1.2	
1490 11108165	-165 -H	8	165	103	15	25.8	46	128	29	15,000	1.2	
1490 11108180	-180 -H	8	180	118	15	27.4	46	143	29	12,000	1.3	
1490 11109105	-PHC09SA -105 -H	9	105	42	16	20.5	46	68	40	23,000	1.1	
1490 11109150	-150 -H	9	150	87	16	25.2	46	113	40	19,000	1.2	
1490 11109165	-165 -H	9	165	103	16	26.8	46	128	40	15,000	1.3	
1490 11109180	-180 -H	9	180	118	16	28.4	46	143	40	12,000	1.3	
1490 11110105	-PHC10SA -105 -H	10	105	42	17	21.5	46	68	40	23,000	1.1	
1490 11110150	-150 -H	10	150	87	17	26.3	46	113	40	19,000	1.2	
1490 11110165	-165 -H	10	165	103	17	27.8	46	128	40	15,000	1.3	
1490 11110180	-180 -H	10	180	119	17	29.5	46	143	40	12,000	1.3	
1490 11111105	-PHC11SA -105 -H	11	105	43	18	22.6	46	68	40	23,000	1.1	
1490 11111150	-150 -H	11	150	88	18	27.3	46	113	40	18,000	1.2	
1490 11111165	-165 -H	11	165	104	18	29.0	46	128	40	14,000	1.3	
1490 11111180	-180 -H	11	180	119	18	30.5	46	143	40	11,000	1.4	
1490 11112105	-PHC12SA -105 -H	12	105	43	19	23.6	46	68	40	22,000	1.1	
1490 11112150	-150 -H	12	150	88	19	28.3	46	113	40	18,000	1.2	
1490 11112165	-165 -H	12	165	104	19	30.0	46	128	40	14,000	1.3	
1490 11112180	-180 -H	12	180	119	19	31.5	46	143	40	11,000	1.4	

1. La tolerancia del diámetro del zanco de la herramienta debe estar dentro de h6 o menor.
2. El tipo de presión alta esta disponible solo para UTS5040.
 1. Tool shank diameter tolerance must be within h6.
 2. Only high pressure type is available for UTS5040.

Ejemplo para Ordenar - Ordering Example

Tipo de alta presión - High pressure type

1.1~7.0MPa

UTS5040 - PHC 06 SA - 150 - H

Interfaz y diámetro de husillo

Diámetro Interior

Longitud de proyección

Tipo de alta presión

Shank size

I.D.

Projection length

High pressure type

Código Code	Modelo Model	d	L	L1	D1	D2	D3	ℓ	ℓ1	min ⁻¹	Kg	Llave Allen (Opcional) Wrench (Option)
1490 1※203090	UTS6350 -PHC03SA -90	3	90	19	11	13.0	46	61	18	20,000	1.1	L-4T
1490 1※203100	-100	3	100	30	11	14.2	46	71	18	20,000	1.1	
1490 1※203145	-145	3	145	71	11	18.5	46	116	18	20,000	1.4	
1490 1※204090	-PHC04SA -90	4	90	19	11	13.0	46	61	24	20,000	1.1	
1490 1※204100	-100	4	100	30	11	14.2	46	71	24	20,000	1.1	
1490 1※204145	-145	4	145	71	11	18.5	46	116	24	19,000	1.4	
1490 1※206105	-PHC06SA -105	6	105	26	13	15.8	46	78	29	20,000	1.4	
1490 1※206150	-150	6	150	71	13	20.5	46	123	29	20,000	1.5	
1490 1※206165	-165	6	165	87	13	22.2	46	138	29	15,000	1.6	
1490 1※206180	-180	6	180	102	13	23.7	46	153	29	12,000	1.6	
1490 1※206195	-195	6	195	118	13	25.4	46	168	29	10,000	1.7	
1490 1※207105	-PHC07SA -105	7	105	26	14	16.8	46	78	29	20,000	1.4	
1490 1※207150	-150	7	150	71	14	21.5	46	123	29	20,000	1.5	
1490 1※207165	-165	7	165	87	14	23.2	46	138	29	15,000	1.6	
1490 1※207180	-180	7	180	102	14	24.7	46	153	29	12,000	1.6	
1490 1※207195	-195	7	195	118	14	26.4	46	168	29	10,000	1.7	
1490 1※208105	-PHC08SA -105	8	105	27	15	17.9	46	78	29	20,000	1.5	
1490 1※208150	-150	8	150	72	15	22.6	46	123	29	20,000	1.5	
1490 1※208165	-165	8	165	87	15	24.2	46	138	29	15,000	1.6	
1490 1※208180	-180	8	180	103	15	25.8	46	153	29	12,000	1.6	
1490 1※208195	-195	8	195	118	15	27.4	46	168	29	10,000	1.7	
1490 1※209120	-PHC09SA -120	9	120	42	16	20.5	46	93	40	20,000	1.5	
1490 1※209150	-150	9	150	72	16	23.6	46	123	40	20,000	1.5	
1490 1※209165	-165	9	165	87	16	25.2	46	138	40	15,000	1.6	
1490 1※209180	-180	9	180	103	16	26.8	46	153	40	12,000	1.7	
1490 1※209195	-195	9	195	118	16	28.4	46	168	40	10,000	1.7	
1490 1※210120	-PHC10SA -120	10	120	42	17	21.5	46	93	40	20,000	1.5	
1490 1※210150	-150	10	150	72	17	24.6	46	123	40	20,000	1.6	
1490 1※210165	-165	10	165	87	17	26.3	46	138	40	15,000	1.6	
1490 1※210180	-180	10	180	103	17	27.8	46	153	40	12,000	1.7	
1490 1※210195	-195	10	195	119	17	29.5	46	168	40	10,000	1.7	
1490 1※211120	-PHC11SA -120	11	120	43	18	22.6	46	93	40	20,000	1.5	
1490 1※211150	-150	11	150	73	18	25.7	46	123	40	19,000	1.6	
1490 1※211165	-165	11	165	88	18	27.3	46	138	40	15,000	1.6	
1490 1※211180	-180	11	180	104	18	29.0	46	153	40	12,000	1.7	
1490 1※211195	-195	11	195	119	18	30.5	46	168	40	10,000	1.8	
1490 1※212120	-PHC12SA -120	12	120	43	19	23.6	46	93	40	20,000	1.5	
1490 1※212150	-150	12	150	73	19	26.7	46	123	40	19,000	1.6	
1490 1※212165	-165	12	165	88	19	28.3	46	138	40	15,000	1.6	
1490 1※212180	-180	12	180	104	19	30.0	46	153	40	12,000	1.7	
1490 1※212195	-195	12	195	119	19	31.5	46	168	40	10,000	1.8	
1490 1※216150	-PHC16SA -150	16	150	72	23	30.6	52.5	90	40	18,000	1.6	
1490 1※216180	-180	16	180	103	23	33.8	52.5	120	40	12,000	1.8	
1490 1※216195	-195	16	195	119	23	35.5	52.5	135	40	10,000	1.9	
1490 1※220150	-PHC20SA -150	20	150	63	28	34.7	62	85	40	18,000	2.1	
1490 1※220180	-180	20	180	93	28	37.8	62	115	40	14,000	2.3	
1490 1※220195	-195	20	195	109	28	39.5	62	130	40	12,000	2.4	
1490 1※225150	-PHC25SA -150	25	150	65	37	43.9	62	85	50	16,000	2.1	
1490 1※225180	-180	25	180	96	37	47.1	62	115	50	14,000	2.4	
1490 1※225195	-195	25	195	112	37	48.8	62	130	50	12,000	2.6	

- BT
- CAT
- AHO
- HSK-A/E/F/C
- HSK-T
- C
- UTS**
- Máquinas Especializadas Specialized Machine
- Equipo Relacionado Related Equipment
- Taladro de Biselado & de Casquillo Bush & Chamfering Drill
- Milling Chuck
- Collet Holder
- "R" Zero Holder
- Hydraulic Chuck
- Shrink Fit
- Tapping Chuck
- Arbors

En el código del producto remplace ※ por Ø si desea ordenar el tipo de baja presión, o, por 1 si desea ordenar el tipo de alta presión.

- La tolerancia del diámetro del zanco de la herramienta debe estar dentro de h6 o menor.
- La velocidad permitida se ve afectada por la rigidez del husillo de la máquina y el balance de la herramienta de corte. Incrementar gradualmente de una velocidad lenta, hasta llegar a la velocidad adecuada.

On the product code replace ※ for Ø if you wish to add low pressure type, or, for 1 if you want high pressure type.

- Tool shank diameter tolerance must be within h6.
- Permissible speed is greatly affected by the stiffness of the machine spindle and the balance of the cutting tool. Gradually increase from a low speed, and use at the proper speed.

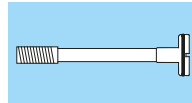
Llave Allen Hex. Wrench Pág. 99 	Tornillo de retención Preset Screw Pág. 432-433 
--	--

Ejemplo para Ordenar - Ordering Example

Tipo de alta presión - High pressure type

0~1.0MPa

UTS6350 -PHC 16 SA- 150

Interfaz y diámetro de husillo Shank size	Diámetro Interior I.D.	Longitud de proyección Projection length
--	---------------------------	---

Ejemplo para Ordenar - Ordering Example

Tipo de alta presión - High pressure type

1.1~7.0MPa

UTS6350 -PHC 16 SA- 150 - H

Interfaz y diámetro de husillo Shank size	Diámetro Interior I.D.	Longitud de proyección Projection length	Tipo de alta presión High pressure type
--	---------------------------	---	--

UTS

Tornillo de preajuste para PHC•SA, PHC•SA-C

Preset Screw for PHC · SA, PHC · SA-C

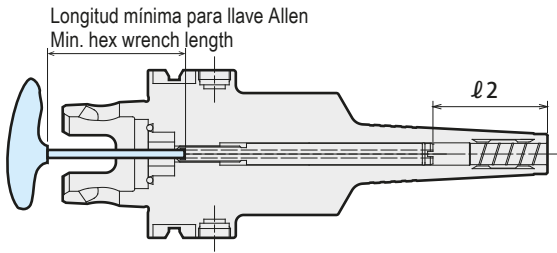

Tipo1
Type1

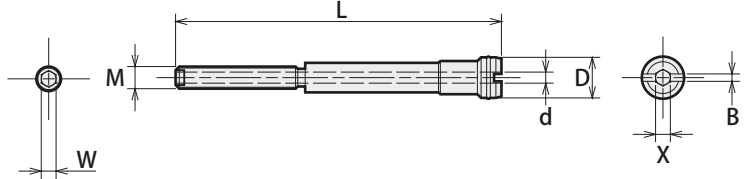

Tipo2
Type2

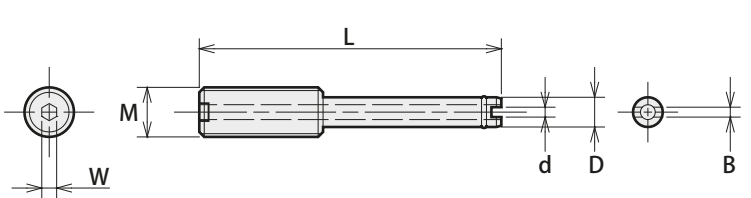

Interfaz y diámetro de husillo Shank size	Longitud mínima para llave Allen Min. hex wrench length
UTS5040	48mm
UTS6350 (PHC03SA-PHC12SA)	60mm
UTS6350 (PHC16SA-PHC25SA)	92mm

Tornillo de preajuste preset screw		Portaherramienta correspondiente Matched chuck	Rango de ajuste Adjustment range t2	Cantidad de ajuste Adjustment amount	Tipo Type	W	X	B	D	d	L	M
Código Code	Modelo Model											
3704 00040123	PHCSA -P04 -012C	UTS5040 -PHC03SA -75	18~34	16	2	2.5	-	1	4	2	27	M5 P=0.8
3704 00040143	PHCSA -P04 -014C	-90	18~34	16	2	2.5	-	1	4	2	37	
3704 00040163	PHCSA -P04 -016C	-135	18~34	16	2	2.5	-	1	4	2	82	
3704 00040113	PHCSA -P04 -011C	-PHC04SA -75	24~40	16	2	2.5	-	1	4	2	21	
3704 00040133	PHCSA -P04 -013C	-90	24~40	16	2	2.5	-	1	4	2	31	
3704 00040153	PHCSA -P04 -015C	-135	24~40	16	2	2.5	-	1	4	2	76	
3704 00060910	PHCSA -P06 -091	-PHC06SA -90	29~50	21	1	3	-	2	6	3	28	M6 P=1
3704 00060920	PHCSA -P06 -092	-150	29~54	25	1	3	-	2	6	3	88	
3704 00060930	PHCSA -P06 -093	-165	29~54	25	1	3	-	2	6	3	103	
3704 00060940	PHCSA -P06 -094	-180	29~54	25	1	3	-	2	6	3	118	
3704 00060910	PHCSA -P06 -091	-PHC07SA -90	29~50	21	1	3	-	2	6	3	28	
3704 00070920	PHCSA -P07 -092	-150	29~54	25	1	3	-	2	7	2	88	
3704 00070930	PHCSA -P07 -093	-165	29~54	25	1	3	-	2	7	2	103	M5 P=0.8
3704 00070940	PHCSA -P07 -094	-180	29~54	25	1	3	-	2	7	2	118	
3704 00060910	PHCSA -P06 -091	-PHC08SA -90	29~50	21	1	3	-	2	6	3	28	
3704 00080920	PHCSA -P08 -092	-150	29~54	25	1	3	-	2	8	3	88	
3704 00080930	PHCSA -P08 -093	-165	29~54	25	1	3	-	2	8	3	103	
3704 00080940	PHCSA -P08 -094	-180	29~54	25	1	3	-	2	8	3	118	
3704 00090910	PHCSA -P09 -091	-PHC09SA -105	40~65	25	1	3	3	2	9	3	32	M6 P=1
3704 00090920	PHCSA -P09 -092	-150	40~65	25	1	3	3	2	9	3	77	
3704 00090930	PHCSA -P09 -093	-165	40~65	25	1	3	3	2	9	3	92	
3704 00090940	PHCSA -P09 -094	-180	40~65	25	1	3	3	2	9	3	107	
3704 00090910	PHCSA -P09 -091	-PHC10SA -105	40~65	25	1	3	3	2	9	3	32	
3704 00100920	PHCSA -P10 -092	-150	40~65	25	1	3	3	2	10	3	77	
3704 00100930	PHCSA -P10 -093	-165	40~65	25	1	3	3	2	10	3	92	M5 P=0.8
3704 00100940	PHCSA -P10 -094	-180	40~65	25	1	3	3	2	10	3	107	
3704 00090910	PHCSA -P09 -091	-PHC11SA -105	40~65	25	1	3	3	2	9	3	32	
3704 00110920	PHCSA -P11 -092	-150	40~65	25	1	3	3	2	11	3	77	
3704 00110930	PHCSA -P11 -093	-165	40~65	25	1	3	3	2	11	3	92	
3704 00110940	PHCSA -P11 -094	-180	40~65	25	1	3	3	2	11	3	107	
3704 00090910	PHCSA -P09 -091	-PHC12SA -105	40~65	25	1	3	3	2	9	3	32	M5 P=0.8
3704 00120920	PHCSA -P12 -092	-150	40~65	25	1	3	3	2	12	3	77	
3704 00120930	PHCSA -P12 -093	-165	40~65	25	1	3	3	2	12	3	92	
3704 00120940	PHCSA -P12 -094	-180	40~65	25	1	3	3	2	12	3	107	
3704 00040121	PHCSA -P04 -012A	UTS6350 -PHC03SA -90	18~38	31	2	2.5	-	1	4	2	27	
3704 00040141	PHCSA -P04 -014A	-100	18~38	31	2	2.5	-	1	4	2	37	
3704 00040161	PHCSA -P04 -016A	-145	18~38	31	2	2.5	-	1	4	2	82	
3704 00040111	PHCSA -P04 -011A	-PHC04SA -90	24~36	31	2	2.5	-	1	4	2	21	
3704 00040131	PHCSA -P04 -013A	-100	24~36	31	2	2.5	-	1	4	2	31	
3704 00040151	PHCSA -P04 -015A	-145	24~36	31	2	2.5	-	1	4	2	76	

BT
CAT
AHO
HSK-A/E/F/C
HSK-T
C
UTS

Máquinas Especializadas
Specialized Machine
Equipo Relacionado
Related Equipment
Tallado de Biselado & de Casquillo
Bush & Chamfering Drill

Milling Chuck

Collet Holder

"R" Zero Holder

Hydraulic Chuck

Shrink Fit

Tapping Chuck

Arbors



Tornillo de preajuste preset screw				Portaherramienta correspondiente Matched chuck	Rango de ajuste Adjustment range \varnothing	Cantidad de ajuste Adjustment amount	Tipo Type	W	X	B	D	d	L	M
Código Code	Modelo Model													
3704 00061010	PHCSA	-P06	-101	-PHC06SA -105	29~51	22	1	3	-	2	6	3	53	M6 P=1
3704 00061020	PHCSA	-P06	-102	-150	29~51	22	1	3	-	2	6	3	98	
3704 00061030	PHCSA	-P06	-103	-165	29~51	22	1	3	-	2	6	3	113	
3704 00061040	PHCSA	-P06	-104	-180	29~51	22	1	3	-	2	6	3	128	
3704 00061050	PHCSA	-P06	-105	-195	29~51	22	1	3	-	2	6	3	143	
3704 00061010	PHCSA	-P06	-101	-PHC07SA -105	29~51	22	1	3	-	2	6	3	53	
3704 00071020	PHCSA	-P07	-102	-150	29~51	22	1	3	-	2	7	2	98	
3704 00071030	PHCSA	-P07	-103	-165	29~51	22	1	3	-	2	7	2	113	
3704 00071040	PHCSA	-P07	-104	-180	29~51	22	1	3	-	2	7	2	128	
3704 00071050	PHCSA	-P07	-105	-195	29~51	22	1	3	-	2	7	2	143	
3704 00061010	PHCSA	-P06	-101	-PHC08SA -105	29~51	22	1	3	-	2	8	3	53	
3704 00081020	PHCSA	-P08	-102	-150	29~51	22	1	3	-	2	8	3	98	
3704 00081030	PHCSA	-P08	-103	-165	29~51	22	1	3	-	2	8	3	113	
3704 00081040	PHCSA	-P08	-104	-180	29~51	22	1	3	-	2	8	3	128	
3704 00081050	PHCSA	-P08	-105	-195	29~51	22	1	3	-	2	8	3	143	
3704 00091010	PHCSA	-P09	-101	-PHC09SA -120	40~62	22	1	3	3	2	9	3	57	
3704 00091020	PHCSA	-P09	-102	-150	40~62	22	1	3	3	2	9	3	87	
3704 00091030	PHCSA	-P09	-103	-165	40~62	22	1	3	3	2	9	3	102	
3704 00091040	PHCSA	-P09	-104	-180	40~62	22	1	3	3	2	9	3	117	
3704 00091050	PHCSA	-P09	-105	-195	40~62	22	1	3	3	2	9	3	132	
3704 00101010	PHCSA	-P10	-101	-PHC10SA -120	40~62	22	1	3	3	2	10	3	57	
3704 00101020	PHCSA	-P10	-102	-150	40~62	22	1	3	3	2	10	3	87	
3704 00101030	PHCSA	-P10	-103	-165	40~62	22	1	3	3	2	10	3	102	
3704 00101040	PHCSA	-P10	-104	-180	40~62	22	1	3	3	2	10	3	117	
3704 00101050	PHCSA	-P10	-105	-195	40~62	22	1	3	3	2	10	3	132	
3704 00111010	PHCSA	-P11	-101	-PHC11SA -120	40~62	22	1	3	3	2	11	3	57	
3704 00111020	PHCSA	-P11	-102	-150	40~62	22	1	3	3	2	11	3	87	
3704 00111030	PHCSA	-P11	-103	-165	40~62	22	1	3	3	2	11	3	102	
3704 00111040	PHCSA	-P11	-104	-180	40~62	22	1	3	3	2	11	3	117	
3704 00111050	PHCSA	-P11	-105	-195	40~62	22	1	3	3	2	11	3	132	
3704 00121010	PHCSA	-P12	-101	-PHC12SA -120	40~62	22	1	3	3	2	12	3	57	
3704 00121020	PHCSA	-P12	-102	-150	40~62	22	1	3	3	2	12	3	87	
3704 00121030	PHCSA	-P12	-103	-165	40~62	22	1	3	3	2	12	3	102	
3704 00121040	PHCSA	-P12	-104	-180	40~62	22	1	3	3	2	12	3	117	
3704 00121050	PHCSA	-P12	-105	-195	40~62	22	1	3	3	2	12	3	132	
3704 00160710	PHCSA	-P16	-071	-PHC16SA -150	40~85	45	1	3	3	2	16	3	55	
3704 00160720	PHCSA	-P16	-072	-180	40~80	40	1	3	3	2	16	3	85	
3704 00160730	PHCSA	-P16	-073	-195	40~80	40	1	3	3	2	16	3	100	
3704 00200710	PHCSA	-P20	-071	-PHC20SA -150	40~80	40	1	3	3	2	20	3	50	
3704 00200720	PHCSA	-P20	-072	-180	40~80	40	1	3	3	2	20	3	80	
3704 00200730	PHCSA	-P20	-073	-195	40~80	40	1	3	3	2	20	3	95	
3704 00250710	PHCSA	-P25	-071	-PHC25SA -150	50~80	30	1	3	3	2	25	3	41	
3704 00250720	PHCSA	-P25	-072	-180	50~90	40	1	3	3	2	25	3	71	
3704 00250730	PHCSA	-P25	-073	-195	50~90	40	1	3	3	2	25	3	86	

※Compatible con tipo de alta presión y baja presión.
 ※Compatible with both high pressure and low pressure.

BT

CAT

AHO

HSK-A/E/F/C

HSK-T

C

UTS

Máquinas
Especializadas
Specialized
Machine

Equipo
Relacionado
Related
Equipment

Taladro de
Biselado & de
Casquillo
Bush &
Chamfering
Drill

Milling Chuck

Collet Holder

"R" Zero Holder

Hydraulic
Chuck

Shrink Fit

Tapping Chuck

Arbors

PHC-H

Hydro Chuck Ω

- El Hydro Chuck Ω de alta rigidez es la mejor opción para maquinados pesados (de alto impacto).
- High Rigidity Hydro Chuck is the best holder for high efficiency rough machining.

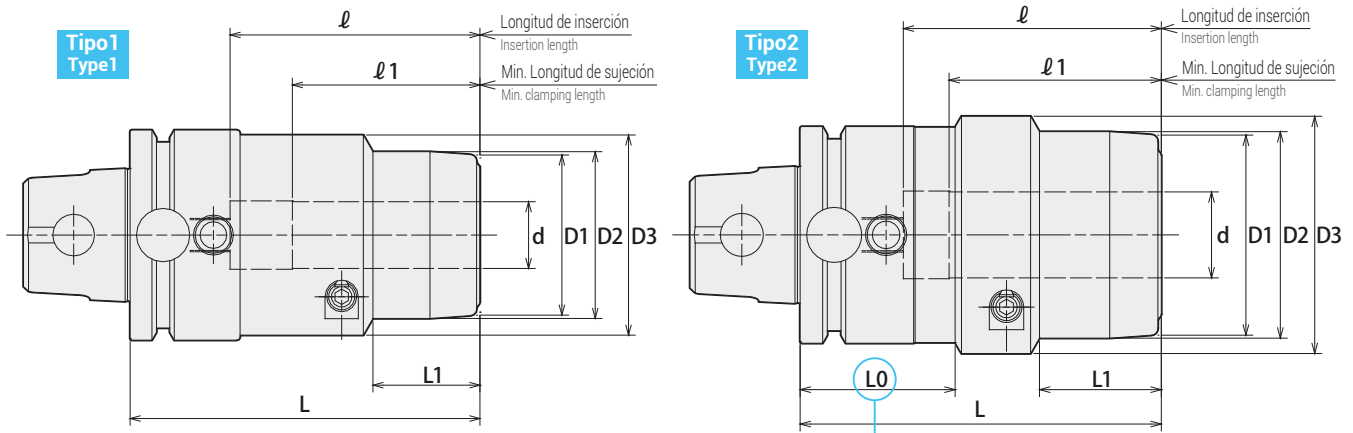

⚠ Precaución / Caution
 Tenga precaución, revise que no tenga interferencia del brazo A.T.C. (automatic tool changer) y el cartucho de herramientas.
 Take caution against A.T.C. arm and tool magazine interference.

Código Code	Modelo Model	Tipo Type	d	L	L1	D1	D2	D3	L0	ℓ	ℓ1	Max. min ⁻¹	kg	Llave Allen (Opcional) Hex. Wrench (Optional)
1440 0 ※ 216075	UTS6350 -PHC16H - 75	1	16	75	25	42	44	56	—	51	45	20,000	1.4	L-4T
1440 0 ※ 220105	-PHC20H - 105	1	20	105	32	48	50	60	—	75	50	20,000	2.0	
1440 0 ※ 225105	-PHC25H - 105	2	25	105	35	58	60	69	44	75	55	16,000	2.3	
1440 0 ※ 232105	-PHC32H - 105	2	32	105	39	63	65	75	44	78	65	12,000	2.3	L-5T
1440 0 ※ 232135	- 135	2	32	135	47	63	65	75	44	105	65	12,000	3.1	
1440 0 ※ 316105	UTS10080 -PHC16H - 105	1	16	105	27	42	44	56	—	70	45	12,500	3.3	L-4T
1440 0 ※ 320105	-PHC20H - 105	1	20	105	32	48	50	60	—	75	50	12,500	3.4	
1440 0 ※ 325105	-PHC25H - 105	1	25	105	35	58	60	69	—	75	55	12,500	3.8	L-5T
1440 0 ※ 325135	- 135	1	25	135	35	58	60	69	—	105	55	12,500	4.5	
1440 0 ※ 332105	-PHC32H - 105	1	32	105	47	63	65	75	—	78	65	12,000	3.8	
1440 0 ※ 332135	- 135	1	32	135	47	63	65	75	—	100	65	12,000	4.7	
1440 0 ※ 342135	-PHC42H - 135	1	42	135	52	78	80	90	—	110	73	10,000	5.5	L-6T

En el código del producto remplace ※ por Ø si desea agregar el tipo de presión baja, o, por 1 si desea agregar el tipo de presión alta.

1. Tolerancia del zanco de diámetro debe ser de h7 o menor. Es recomendada una tolerancia h6 o 0/-0.01 para nuevas herramientas de corte.
2. PHC20H Y PHC32H cuentan con orificios de acople para perno, para las boquillas que tienen incluido el perno de retención.
3. La velocidad permitida se ve afectada por la rigidez del husillo de la máquina y el balance de la herramienta de corte. Incrementar gradualmente de una velocidad lenta, hasta llegar a la velocidad adecuada.

Boquilla PHS+H PHS+H Collet	Tomillo de retención Stopper Bolt
Pág. 123	Pág. 123

On the product code replace ※ for Ø if you wish to add low pressure type, or, for 1 if you want high pressure type.

1. Tool shank diameter tolerance must be within h7. h6 or 0/-0.01 tolerance is recommended when newly making a cutting tool.
2. PHC20H and PHC32H have pin holes for collet with stopper pin on its body.
3. Allowed speed is greatly affected by the stiffness of the machine spindle and the balance of the cutting tool. Gradually increase from a low speed, and use at the proper speed.

Ejemplo para Ordenar - Ordering Example

Tipo de baja presión - Low pressure type
 0 ~ 1.0MPa

UTS6350 - PHC 16 H-75

Interfaz y diámetro de husillo Shank size	Diámetro Interno I.D.	Longitud de proyección Projection length
--	--------------------------	---

Ejemplo para Ordenar - Ordering Example

Tipo de alta presión - High pressure type
 1.1 ~ 7.0MPa

UTS6350 - PHC 16 H - 75 - H

Interfaz y diámetro de husillo Shank size	Diámetro Interno I.D.	Longitud de proyección Projection length	Tipo de alta presión High pressure type
--	--------------------------	---	--

NOTAS

Shrink Fit (Heavy Type)

- El método de contracción coloca firmemente a una herramienta de corte al calentar y enfriar el portaherramienta. Alta precisión, rigidez y un fresado fuerte. (Tipo pesado)
- Shrinkage method sets a cutting tool firmly by heating and cooling the chuck. High precision and strong Clamping force. (Heavy Type)

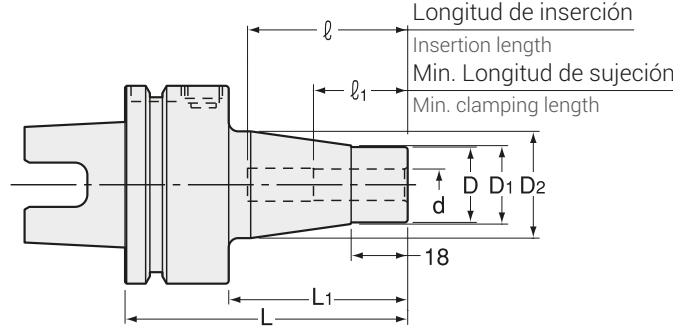

Medidas Métricas - Metric Sizes

Unidad : Métrico
Unit : Metric

Código Code	Modelo Model	d	L	L1	D	D1	D2	ℓ1	ℓ
1300 01106090	UTS5040 -SRK 6A -90-H	6	90	60	16	17	30	26	26 ~ 36
1300 01108090	UTS5040 -SRK 8A -90-H	8	90	60	19	20	32	26	26 ~ 50
1300 01110085	UTS5040 -SRK10A -85-H	10	85	55	24	25	34	32	32 ~ 50
1300 01112090	UTS5040 -SRK12A -90-H	12	90	60	28	29	34	37	37 ~ 65
1300 01116095	UTS5040 -SRK16A -95-H	16	95	65	32	33	34	40	40 ~ 70
1300 01120100	UTS5040 -SRK20A -100-H	20	100	70	36	37	42	42	42 ~ 75
1300 0 ※ 206090	UTS6350 -SRK 6A -90	6	90	57	16	17	30	26	26 ~ 36
1300 0 ※ 208090	UTS6350 -SRK 8A -90	8	90	57	19	20	32	26	26 ~ 50
1300 0 ※ 210085	UTS6350 -SRK10A -85	10	85	52	24	25	34	32	32 ~ 50
1300 0 ※ 212090	UTS6350 -SRK12A -90	12	90	57	28	29	34	37	37 ~ 63
1300 0 ※ 216095	UTS6350 -SRK16A -95	16	95	62	32	33	34	40	40 ~ 65
1300 0 ※ 220100	UTS6350 -SRK20A -100	20	100	67	36	37	42	42	42 ~ 72
1300 0 ※ 225115	UTS6350 -SRK25A -115	25	115	82	46	47	53	48	48 ~ 89
1300 0 ※ 306090	UTS10080 -SRK 6A -90	6	90	56	16	17	30	26	26 ~ 36
1300 0 ※ 308090	UTS10080 -SRK 8A -90	8	90	56	19	20	32	26	26 ~ 50
1300 0 ※ 310090	UTS10080 -SRK10A -90	10	90	56	24	25	34	32	32 ~ 50
1300 0 ※ 312095	UTS10080 -SRK12A -95	12	95	61	28	29	34	37	37 ~ 62
1300 0 ※ 316100	UTS10080 -SRK16A -100	16	100	66	32	33	34	40	40 ~ 65
1300 0 ※ 320105	UTS10080 -SRK20A -105	20	105	71	36	37	42	42	42 ~ 70
1300 0 ※ 325115	UTS10080 -SRK25A -115	25	115	81	46	47	53	48	48 ~ 80
1300 0 ※ 332120	UTS10080 -SRK32A -120	32	120	86	56	57	70	51	51 ~ 85

Tabla de dispositivos térmicos Heating device chart

Dispositivo térmico Heating device	Portaherramienta - chuck	
	SRK6A, SRK8A	SRK10A~SRK32A
ISG3400	Sí / Yes	Sí / Yes *
SRK-HA1, HB2	No	Sí / Yes

*Se necesita la bobina de inducción. Diríjase a la pág. 486-487.
*Special induction coil is needed. Refer to P.486-487.

Al hacer su orden, favor de especificar entre presión alta o baja. Para el tipo de presión alta, favor de agregar (-H) al final de la descripción.

1. Siempre use herramientas de zanco de carburo con tolerancia de h6.
2. El UTS5040 sólo está disponible en presión alta.

When placing an order, please specify high or low pressure. For high pressure type, please add (-H) on end of the description.

1. Always use carbide shank tools with h6 tolerance.
2. UTS5040 is available in high pressure only.

Ejemplo para Ordenar - Ordering Example

Tipo de baja presión - Low pressure type
0 ~ 1.0MPa (UTS10080 : 0 ~ 2.0MPa)

UTS6350 - SRK 10 A - 85
 Interfaz y diámetro de husillo / Shank size: 10
 Diámetro Interno / I.D. (d): A
 Longitud de proyección / Projection length (L): 85

Ejemplo para Ordenar - Ordering Example

Tipo de alta presión - High pressure type
1.1 ~ 7.0MPa (UTS10080 : 2.1 ~ 7.0MPa)

UTS6350 - SRK 10 A - 85 - H
 Interfaz y diámetro de husillo / Shank size: 10
 Diámetro Interno / I.D. (d): A
 Longitud de proyección / Projection length (L): 85
 Tipo de alta presión / High pressure type: H

Shrink Fit (Slim Type)

- El método de contracción sujeta firmemente a una herramienta de corte al calentar y enfriar el portaherramienta. Alta precisión y mucha fuerza de fresado. (Tipo delgado)
- Shrinkage method clamps a cutting tool firmly by heating and cooling the chuck. High precision and strong Clamping force. (Slim Type)

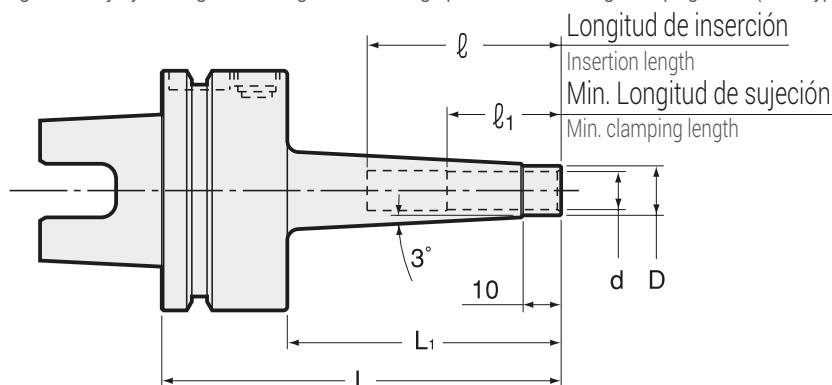

Medidas Métricas - Metric Sizes

Unidad : Métrico
Unit : Metric

Código Code	Modelo Model	d	L	L1	D	l1	l
1300 31106090	UTS5040 -SRS6A -90-H	6	90	60	9	26	26 ~ 36
1300 31106120	-120-H	6	120	90	9	26	26 ~ 36
1300 31108090	UTS5040 -SRS8A -90-H	8	90	60	11	26	26 ~ 50
1300 31108120	-120-H	8	120	90	11	26	26 ~ 50
1300 31110105	UTS5040 -SRS10A -105-H	10	105	75	13	32	32 ~ 50
1300 31110135	-135-H	10	135	105	13	32	32 ~ 50
1300 31112105	UTS5040 -SRS12A -105-H	12	105	75	15	37	37 ~ 65
1300 31112135	-135-H	12	135	105	15	37	37 ~ 70
1300 31116105	UTS5040 -SRS16A -105-H	16	105	75	20	40	40 ~ 80
1300 31116135	-135-H	16	135	105	20	40	40 ~ 80
1300 31120105	UTS5040 -SRS20A -105-H	20	105	75	26	42	42 ~ 80
1300 31120135	-135-H	20	135	105	26	42	42 ~ 100
1300 3 * 206105	UTS6350 -SRS6A -105	6	105	72	9	26	26 ~ 36
1300 3 * 206135	-135	6	135	102	9	26	26 ~ 36
1300 3 * 206165	-165	6	165	132	9	26	26 ~ 36
1300 3 * 208105	UTS6350 -SRS8A -105	8	105	72	11	26	26 ~ 50
1300 3 * 208135	-135	8	135	102	11	26	26 ~ 50
1300 3 * 208165	-165	8	165	132	11	26	26 ~ 50
1300 3 * 210105	UTS6350 -SRS10A -105	10	105	72	13	32	32 ~ 50
1300 3 * 210135	-135	10	135	102	13	32	32 ~ 50
1300 3 * 210165	-165	10	165	132	13	32	32 ~ 50
1300 3 * 212105	UTS6350 -SRS12A -105	12	105	72	15	37	32 ~ 70
1300 3 * 212135	-135	12	135	102	15	37	32 ~ 70
1300 3 * 212165	-165	12	165	132	15	37	32 ~ 70
1300 3 * 216105	UTS6350 -SRS16A -105	16	105	72	20	40	40 ~ 75
1300 3 * 216135	-135	16	135	102	20	40	40 ~ 80
1300 3 * 216165	-165	16	165	132	20	40	40 ~ 80
1300 3 * 220105	UTS6350 -SRS20A -105	20	105	72	26	42	42 ~ 75
1300 3 * 220135	-135	20	135	102	26	42	42 ~ 100
1300 3 * 220165	-165	20	165	132	26	42	42 ~ 100
1300 3 * 306105	UTS10080 -SRS6A -105	6	105	71	9	26	26 ~ 36
1300 3 * 306135	-135	6	135	101	9	26	26 ~ 36
1300 3 * 306165	-165	6	165	131	9	26	26 ~ 36
1300 3 * 308105	UTS10080 -SRS8A -105	8	105	71	11	26	26 ~ 50
1300 3 * 308135	-135	8	135	101	11	26	26 ~ 50
1300 3 * 308165	-165	8	165	131	11	26	26 ~ 50
1300 3 * 310105	UTS10080 -SRS10A -105	10	105	71	13	32	32 ~ 50
1300 3 * 310135	-135	10	135	101	13	32	32 ~ 50
1300 3 * 310165	-165	10	165	131	13	32	32 ~ 50
1300 3 * 310195	-195	10	195	161	13	32	32 ~ 50

Medidas Métricas - Metric Sizes

Unidad : Métrico
Unit : Metric

Código Code	Modelo Model	d	L	L1	D	ℓ1	ℓ
1300 3 ※ 312105	UTS10080 -SRS12A -105	12	105	71	15	37	37 ~ 70
1300 3 ※ 312135	-135	12	135	101	15	37	37 ~ 70
1300 3 ※ 312165	-165	12	165	131	15	37	37 ~ 70
1300 3 ※ 312195	-195	12	195	161	15	37	37 ~ 70
1300 3 ※ 316105	UTS10080 -SRS16A -105	16	105	71	20	40	40 ~ 70
1300 3 ※ 316135	-135	16	135	101	20	40	42 ~ 80
1300 3 ※ 316165	-165	16	165	131	20	40	42 ~ 80
1300 3 ※ 316195	-195	16	195	161	20	40	42 ~ 80
1300 3 ※ 320105	UTS10080 -SRS20A -105	20	105	71	26	42	42 ~ 70
1300 3 ※ 320135	-135	20	135	101	26	42	42 ~ 100
1300 3 ※ 320165	-165	20	165	131	26	42	42 ~ 100
1300 3 ※ 320195	-195	20	195	161	26	42	42 ~ 100

Al hacer su orden, favor de especificar entre presión alta o baja. Para el tipo de presión alta, favor de agregar (-H) al final de la descripción.

1. Siempre use herramientas de zanco de carburo con de tolerancia h6.
2. El UTS5040 sólo está disponible en presión alta.

When placing an order, please specify high or low pressure. For high pressure type, please add (-H) on end of the description.

1. Always use carbide shank tools with h6 tolerance.
2. UTS5040 is available in high pressure only.

Tabla de dispositivos térmicos Heating device chart		
Dispositivo térmico Heating device	Portaherramienta - chuck	
	SRS0250A, SRS0312A SRS6A, SRS8A	SRS0375A~SRS0750A SRS10A~SRS20A
ISG3400	Sí / Yes	Sí / Yes
SRK-HA1, HB2	No	Sí / Yes

Ejemplo para Ordenar - Ordering Example

Tipo de baja presión - Low pressure type
0 ~ 1.0MPa (UTS10080 : 0 ~ 2.0MPa)

UTS6350 - SRS 10 A - 105

Interfaz y diámetro de husillo Diámetro Interno Longitud de proyección
Shank size I.D. (d) Projection length (L)

Ejemplo para Ordenar - Ordering Example

Tipo de alta presión - High pressure type
1.1 ~ 7.0MPa (UTS10080 : 2.1 ~ 7.0MPa)

UTS6350 - SRS 10 A - 105 - H

Interfaz y diámetro de husillo Diámetro Interno Longitud de proyección Tipo de alta presión
Shank size I.D. (d) Projection length (L) High pressure type

NOTAS

STM

Synchronous Tap Holder With Easy Tool Length Adjustment

- La longitud de proyección de la herramienta de corte se puede ajustar simplemente girando la circunferencia del portaherramienta.
- Projection length of the cutting tool can be adjusted by simply turning circumference of the holder.

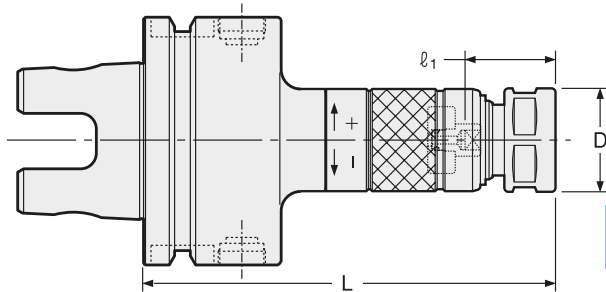

! Para consultar las medidas de machuelo adecuados, favor de dirigirse a la tabla en las pág. 484-486.
For capable tap sizes, please refer to P.484-486 chart.

(NOTA) El D.E. de la tuerca del STM8 es de 19 mm.
(NOTE) Nut O.D. of STM8 is 19mm.

Portaherramienta STM + **Boquilla** + **Impulsor STS**
STM Holder + Collet + STS Driver

Unidad : Métrico
Unit : Metric



Código Code	Modelo Model	Medida de machuelo Tap Size	L	D	Tuerca ciega Nut	kg	Boquilla Collet	Conductor de preajustada Preset Driver	Llave Inglesa Spanner
1370 00400090	UTS5040 -STM8 -90H	Old JIS Taps	90	21	KDP-1414				
1370 00400105	-105H	M4 ~ 8 U No8 ~ 5/16	105	21	KDP-1414		FDC-07	STS-8	Llave con 17 mm de ancho (Flat 17mm width)
1370 00400120	-120H	OSG Synchro Taps M4 ~ 6	120	21	KDP-1414				
1370 10400090	UTS5040 -STM12 -90H	Old JIS Taps	90	26	HTP-09				
1370 10400105	-105H	M4 ~ 12 U No8 ~ 7/16 PT1/8	105	26	HTP-09		FSC-09	STS-12	S-1L
1370 10400120	-120H	OSG Synchro Taps M4 ~ 10	120	26	HTP-09				
1370 30400105	UTS5040 -STM18 -105H	Old JIS Taps	105	36	HTP-16				
1370 30400120	-120H	M14 ~ 18 U1/2 ~ 3/4 PT1/4 ~ 3/8	120	36	HTP-16		FSC-16	STS-18	S-4L
1370 30400135	-135H	OSG Synchro Taps	135	36	HTP-16				
1370 30400150	-150H	M12 ~ 14	150	36	HTP-16				
1370 40400120	UTS5040 -STM30 -120H	Old JIS Taps	120	46	HTP-22				
1370 40400135	-135H	M20 ~ 30 U7/8 ~ 1-1/8 PT1/2 ~ 3/4	135	46	HTP-22		FSC-22	STS-30	S-5L
1370 40400150	-150H	OSG Synchro Taps M16 ~ 27	150	46	HTP-22				
1370 00 * 00090	UTS6350 -STM8 -90 *	Old JIS Taps	90	21	KDP-1414				
1370 00 * 00105	-105	M4 ~ 8 U No8 ~ 5/16	105	21	KDP-1414		FDC-07	STS-8	Llave con 17 mm de ancho (Flat 17mm width)
1370 00 * 00120	-120	OSG Synchro Taps M4 ~ 6	120	21	KDP-1414				
1370 00 * 00135	-135		135	21	KDP-1414				
1370 00 * 00150	-150		150	21	KDP-1414				
1370 10 * 00090	UTS6350 -STM12 -90 *	Old JIS Taps	90	26	HTP-09				
1370 10 * 00105	-105	M4 ~ 12 U No8 ~ 7/16 PT1/8	105	26	HTP-09	1.1	FSC-09	STS-12	S-1L
1370 10 * 00120	-120	OSG Synchro Taps	120	26	HTP-09				
1370 10 * 00135	-135	M4 ~ 10	135	26	HTP-09				
1370 10 * 00150	-150		150	26	HTP-09				
1370 10 * 00180	-180		180	26	HTP-09				
1370 30 * 00105	UTS6350 -STM18 -105	Old JIS Taps	105	36	HTP-16	1.2	FSC-16	STS-18	S-4L
1370 30 * 00120	-120	M14 ~ 18 U1/2 ~ 3/4 PT1/4 ~ 3/8	120	36	HTP-16				
1370 30 * 00135	-135	OSG Synchro Taps	135	36	HTP-16				
1370 30 * 00150	-150	M12 ~ 14	150	36	HTP-16				
1370 30 * 00180	-180		180	36	HTP-16				
1370 40 * 00120	UTS6350 -STM30 -120	Old JIS Taps	120	46	HTP-22				
1370 40 * 00135	-135	M20 ~ 30 U7/8 ~ 1-1/8 PT1/2 ~ 3/4	135	46	HTP-22		FSC-22	STS-30	S-5L
1370 40 * 00150	-150	OSG Synchro Taps	150	46	HTP-22				
1370 40 * 00180	-180	M16 ~ 27	180	46	HTP-22				
1370 00 * 00090	UTS10080 -STM8 -90 *	Old JIS Taps	90	21	KDP-1414				
1370 00 * 00105	-105	M4 ~ 8 U No8 ~ 5/16	105	21	KDP-1414		FDC-07	STS-8	Llave con 17 mm de ancho (Flat 17mm width)
1370 00 * 00120	-120	OSG Synchro Taps M4 ~ 6	120	21	KDP-1414				
1370 00 * 00135	-135		135	21	KDP-1414				
1370 00 * 00150	-150		150	21	KDP-1414				
1370 00 * 00165	-165		165	21	KDP-1414				
1370 10 * 00090	UTS10080 -STM12 -90 *	Old JIS Taps	90	26	HTP-09				
1370 10 * 00105	-105	M4 ~ 12 U No8 ~ 7/16 PT1/8	105	26	HTP-09		FSC-09	STS-12	S-1L
1370 10 * 00120	-120	OSG Synchro Taps	120	26	HTP-09				
1370 10 * 00135	-135	M4 ~ 10	135	26	HTP-09	2.8			
1370 10 * 00150	-150		150	26	HTP-09				
1370 10 * 00180	-180		180	26	HTP-09				
1370 30 * 00105	UTS10080 -STM18 -105	Old JIS Taps	105	36	HTP-16	2.7	FSC-16	STS-18	S-4L
1370 30 * 00120	-120	M14 ~ 18 U1/2 ~ 3/4 PT1/4 ~ 3/8	120	36	HTP-16				
1370 30 * 00135	-135	OSG Synchro Taps	135	36	HTP-16				
1370 30 * 00150	-150	M12 ~ 14	150	36	HTP-16	3.0			
1370 30 * 00180	-180		180	36	HTP-16				
1370 40 * 00120	UTS10080 -STM30 -120	Old JIS Taps	120	46	HTP-22				
1370 40 * 00135	-135	M20 ~ 30 U7/8 ~ 1-1/8 PT1/2 ~ 3/4	135	46	HTP-22		FSC-22	STS-30	S-5L
1370 40 * 00150	-150	OSG Synchro Taps	150	46	HTP-22				
1370 40 * 00180	-180	M16 ~ 27	180	46	HTP-22				
1370 40 * 00210	-210		210	46	HTP-22				

Al hacer su orden, favor de especificar entre presión alta o baja. Para el tipo de presión alta, favor de agregar (-H) al final de la descripción.

When placing an order, please specify high or low pressure. For high pressure type, please add (-H) on end of the description.

- 1.La boquilla, la llave inglesa y unidad preajustada se venden por separado.
- 2.Favor de ver a continuación para conocer la dimensión $\ell 1$.
- 3.El STM8 puede hacer orificios del machuelo menores a M4. Las boquillas a usar son como se especifica a continuación.
M1.M2.6: FDC-03007-*** M3-M3.5: FDC-04007-***
La boquilla de machuelo no se usará para los usos antes mencionados.
- 4.El UTS5040 sólo está disponible en presión alta.

- 1.Collet, spanner and preset driver are sold separately.
- Please see below for $\ell 1$ dimension.
Tap holes smaller than M4 can be made by STM8. Collets to be used are as follows.
M1-M2.6: FDC-03007-*** M3-M3.5: FDC-04007-***
Tap drive will not be used for the above usages.
- 4.UTS5040 is available in high pressure only.

Boquilla Collet Pág. 442	Tornillo de preajuste Preset screw Pág. 442-443
	

Ejemplo para Ordenar - Ordering Example

Tipo de baja presión - Low pressure type
0 ~ 1.0MPa (UTS10080 : 0 ~ 2.0MPa)

UTS6350 - STM	12	-	90
Interfaz y diámetro de husillo Shank size	Medida de portaherramienta Holder size		Longitud de proyección Projection length (L)

Ejemplo para Ordenar - Ordering Example

Tipo de alta presión - High pressure type
1.1 ~ 7.0MPa (UTS10080 : 2.1 ~ 7.0MPa)

UTS6350 - STM	12	-	90	-	H
Interfaz y diámetro de husillo Shank size	Medida de portaherramienta Holder size		Longitud de proyección Projection length (L)		Tipo de alta presión High pressure type

Dimensión $\ell 1$ para el STM - $\ell 1$ Dimension for STM

Machuelos JIS antiguas - Old JIS Taps			
Sin vena de refrigerante a través del centro Without center-through coolant			
Medida de machuelo - Tap Size	$\ell 1$	$\ell 1$ (*)	
M4 ~ 6 U No.8 ~ 1/4	21 ~ 35	21 ~ 26	
M7 ~ 12 U 5/16 ~ U7/16 PT1/8	23 ~ 37	23 ~ 28	
M13 ~ 15 U 1/2 ~ 5/8 PT1/4	28 ~ 42	-	
M16 ~ 17 M18 ~ 27 U 3/4 ~ U1 PT3/8 ~ 5/8	32 ~ 45 33 ~ 47	-	
M30 U1-1/8 PT3/4	38 ~ 52	-	
Con vena de refrigerante a través del centro With center-through coolant (STM8)			
Medida de machuelo - Tap Size	$\ell 1$	$\ell 1$ (*)	
M4 ~ 6 U No.8 ~ 1/4	25 ~ 35	25 ~ 26	
M7 ~ 8 U5/16	26 ~ 37	26 ~ 28	
Con vena de refrigerante a través del centro With center-through coolant (STM12~30)			
Medida de machuelo - Tap Size	$\ell 1$	$\ell 1$ (*)	
M4 ~ 6 U No.8 ~ 1/4	24 ~ 35	24 ~ 26	
M7 ~ 10 U 5/16 ~ 3/8	25 ~ 37	25 ~ 28	
M11 ~ 12 U 7/16 PT 1/8	26 ~ 37	26 ~ 28	
U1/2	32 ~ 42	-	
M13 ~ 15 U9/16	33 ~ 42	-	
U5/8 PT1/4	34 ~ 42	-	
M16	35 ~ 46	-	
M18 U 3/4 PT3/8	36 ~ 47	-	
M20 ~ 21 PT1/2	40 ~ 47	-	
M22 U 7/8	41 ~ 47	-	
M23	42 ~ 47	-	
M24 ~ 25 PT5/8	43 ~ 47	-	
M26 ~ 27 U1	44 ~ 47	-	
M28	45 ~ 52	-	
M30 PT3/4	46 ~ 52	-	
U 1-1/8	48 ~ 52	-	

Machuelos sincronizados OSG - OSG Synchro Taps			
Sin vena de refrigerante a través del centro Without center-through coolant			
Medida de machuelo - Tap Size	$\ell 1$	$\ell 1$ (*)	
M4 ~ 6	21 ~ 35	21 ~ 26	
M8 ~ 10	23 ~ 37	23 ~ 28	
M12 ~ 14	28 ~ 42	-	
M16 ~ 27	33 ~ 47	-	
Con vena de refrigerante a través del centro With center-through coolant (STM8)			
Medida de machuelo - Tap Size	$\ell 1$	$\ell 1$ (*)	
M4 ~ 6	25 ~ 35	25 ~ 26	
Con vena de refrigerante a través del centro With center-through coolant (STM12~30)			
Medida de machuelo - Tap Size	$\ell 1$	$\ell 1$ (*)	
M4 ~ 6	24 ~ 35	24 ~ 26	
M8 ~ 10	26 ~ 37	26 ~ 28	
M12	33 ~ 42	-	
M14	34 ~ 42	-	
M16 ~ 20	40 ~ 46	-	
M22 ~ 27	44 ~ 47	-	

YAMAWA X Series			
Sin vena de refrigerante a través del centro Without center-through coolant			
Medida de machuelo - Tap Size	$\ell 1$	$\ell 1$ (*)	
M6 M8	23 ~ 37	23 ~ 28	
M10 M12	28 ~ 42	-	
Con vena de refrigerante a través del centro With center-through coolant (STM8)			
Medida de machuelo - Tap Size	$\ell 1$	$\ell 1$ (*)	
M6	26 ~ 37	26 ~ 28	
Con vena de refrigerante a través del centro With center-through coolant (STM12~30)			
Medida de machuelo - Tap Size	$\ell 1$	$\ell 1$ (*)	
M6	25 ~ 37	25 ~ 28	
M8	26 ~ 37	26 ~ 28	
M10	33 ~ 42	-	
M12	34 ~ 42	-	

- BT
- CAT
- AHO
- HSK-A/E/F/C
- HSK-T
- C
- UTS**
- Maquinas Especializadas
Specialized Machine
- Equipo Relacionado
Related Equipment
- Taladro de Biselado & de Casquillo
Bush & Chamfering Drill
- Milling Chuck
- Collet Holder
- "R" Zero Holder
- Hydraulic Chuck
- Shrink Fit
- Tapping Chuck
- Arbors

Tabla de referencia de las medidas de machuelo de roscar (boquilla, conductor de preajuste)

Tap size reference chart (collet, preset driver)

FDC 07 ó / or FSC - boquilla (collet)

Unidad de cambio del conductor de preajuste y herramienta
Preset driver & tool for changing driver

Tipo OH - Type OH

● La boquilla OH debe usarse para el abastecimiento de refrigerante a través del centro y para el abastecimiento de refrigerante externo.

● OH type collet should be used for center-through coolant feeding and external coolant feeding.

Tipo C - Type C

● Cuando se necesita el abastecimiento de refrigerante "a través de la boquilla"

● when "collet-through" coolant feeding is needed.

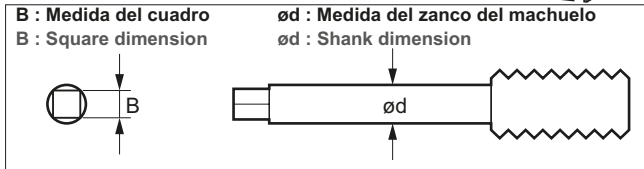
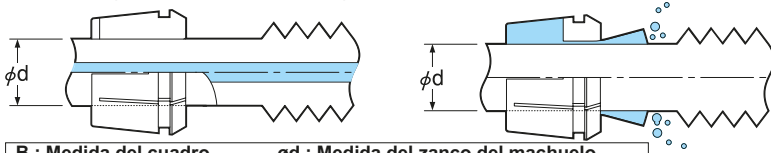

※ Favor de elegir el tipo OH para un uso sin refrigerante.
※ Please select OH type for non-coolant use.

Tipo STS - Type STS

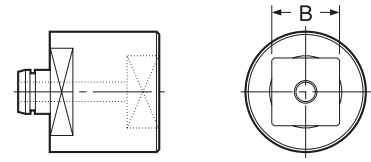

Tipo STS-R - Type STS-R

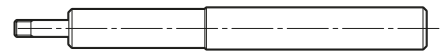

Modelo de portaherramienta Holder Model	Tamaño de machuelo Tap Size (ANSI)	ød (pulgada-inch)	ød (mm)	Modelo de Boquilla Collet Model (OH or C)	B (inch)	B (mm)	Conductor de preajuste Preset Driver
STM8	#0-6	0.141	3.5814	FDC-03607**	0.110	2.794	STS8- □ 2.8
	#8	0.168	4.2672	FDC-04307**	0.131	3.3274	STS8- □ 3.4
	#10	0.194	4.9276	FDC-05007**	0.152	3.8608	STS8- □ 4.0
	#12	0.22	5.588	FDC-05607**	0.165	4.191	STS8- □ 4.2
	1/4	0.255	6.477	FDC-06507**	0.191	4.8514	STS8- □ 5.0
STM12	#0-6	0.141	3.5814	FSC-09-3.6**	0.110	2.794	STS12- □ 2.8
	#8	0.168	4.2672	FSC-09-4.3**	0.131	3.3274	STS12- □ 3.4
	#10	0.194	4.9276	FSC-09-5.0**	0.152	3.8608	STS12- □ 4.0
	#12	0.22	5.588	FSC-09-5.6**	0.165	4.191	STS12- □ 4.2
	1/4	0.255	6.477	FSC-09-6.5**	0.191	4.8514	STS12- □ 5.0
	1/8SPT	0.313	7.9502	FSC-09-8.0**	0.234	5.9436	STS12- □ 6.0
	5/16	0.318	8.0772	FSC-09-8.1**	0.238	6.0452	STS12- □ 6.1
	7/16	0.323	8.2042	FSC-09-8.3**	0.242	6.1468	STS12- □ 6.2
STM18	1/2	0.367	9.3218	FSC-16-9.4**	0.275	6.985	STS18- □ 7.0
	3/8	0.381	9.6774	FSC-16-9.7**	0.286	7.2644	STS18- □ 7.3
	9/16	0.429	10.8966	FSC-16-10.9**	0.322	8.1788	STS18- □ 8.2
	1/8LPT	0.437	11.0998	FSC-16-11.1**	0.328	8.3312	STS18- □ 8.4
	5/8	0.48	12.192	FSC-16-12.2**	0.360	9.144	STS18- □ 9.2
	11/16	0.542	13.7668	FSC-16-13.8**	0.406	10.3124	STS18- □ 10.4
	1/4PT	0.562	14.2748	FSC-16-14.3**	0.421	10.6934	STS18- □ 10.7
STM30	3/4	0.59	14.986	FSC-22-15.0**	0.442	11.2268	STS30- □ 11.3
	13/16	0.652	16.5608	FSC-22-16.6**	0.489	12.4206	STS30- □ 12.5
	7/8	0.697	17.7038	FSC-22-17.8**	0.523	13.2842	STS30- □ 13.3
	3/8PT	0.7	17.78	FSC-22-17.8**	0.531	13.4874	STS30- □ 13.5
	1	0.8	20.32	FSC-22-20.4**	0.600	15.24	STS30- □ 15.3

Para DIN e ISO, favor de dirigirse a la pág. 485-486. **Ejemplo para Ordenar - Ordering Example**

For DIN and ISO, please refer to P.485-486.

FSC - 22 - 20.4 - OH

Medida de la boquilla
Collet size

D.I. de la boquilla
Collet I.D. (d)

OH: Para herramienta con vena de lubricación

C: Para refrigeración a través de los costados de la boquilla

OH: For tool with coolant hole

C: For collet through

Combinación de accesorios - Accessories combination

Portaherramienta para machuelo - Tap holder	Boquilla Collet	Conductor de preajuste Preset Driver		Tuerca ciega Nut		Unidad de cambio de herramienta Tool changing driver		Llave Inglesa Spanner	
Modelo Model	Modelo Model	Modelo Model	Código Code	Modelo Model	Código Code	Modelo Model	Código Code	Modelo Model	Código Code
STM8	FDC-07	STS8	3914 0100**03	KDP-1414	0070 01001407	STS-R0	3914 00000006	Llave con 17 mm de ancho (Flat 17mm width)	
STM12	FSC-09	STS12	3914 1100**03	HTP-09	1314 00000009	STS-R1	3914 10000006	S-1L	0803 00000011
STM18	FSC-16	STS18	3914 310***03	HTP-16	1314 00000016	STS-R2	3914 30000006	S-4L	0803 00000014
STM30	FSC-22	STS30	3914 410***03	HTP-22	1314 00000022	STS-R2	3914 30000006	S-5L	0803 00000015

Tabla de referencia de las medidas de machuelo de roscar (boquilla, conductor de preajuste)

Tap size reference chart (collet, preset driver)

FDC 07 6 / or FSC - boquilla (collet)

Tipo OH - Type OH

● La boquilla OH debe usarse para el abastecimiento de refrigerante a través del centro y para el abastecimiento de refrigerante externo.

● OH type collet should be used for center-through coolant feeding and external coolant feeding.

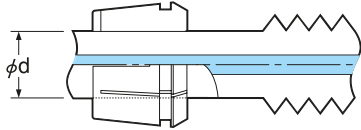

Tipo C - Type C

● Cuando se necesita el abastecimiento de refrigerante "a través de la boquilla"

● when "collet-through" coolant feeding is needed.

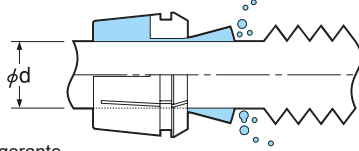

※ Favor de elegir el tipo OH para un uso sin refrigerante.
 ※ Please select OH type for non-coolant use.

Unidad de cambio del conductor de preajuste y herramienta Preset driver & tool for changing driver

Tipo STS - Type STS

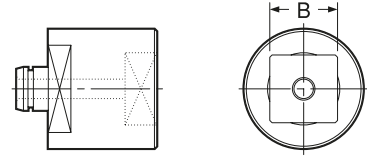

Tipo STS-R - Type STS-R

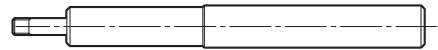

Modelo de portaherramienta Holder Model	Medida de machuelo - Tap Size					ød	Modelo de Boquilla Collet Model (OH or C)	B	Conductor de preajuste Preset Driver	Herramienta para cambiar la Unidad preajustada / Tool for Changing Driver		
	Machuelos JIS antiguas - Old JIS Taps			Machuelo sincronizado OSG-OSG Synchro-Taps	YAMAHA X Series							
	Rosca métrica Metric Thread	Rosca unificada Unified Thread	Rosca de tubo ahusado Pipe Taper Thread									
STM8	M4-M4.5	UNo.8		M4-M6	M6	5.0	FDC-05007-**	4.0	STS8-□4.0	STS-R0		
	M5-M5.5	UNo.10-12				5.5	FDC-05507-**	4.5	STS8-□4.5	STS-R0		
	M6	U1/4				6.0	FDC-06007-**	4.5	STS8-□4.5	STS-R0		
						6.0	FDC-06007-**	4.9	STS8-□4.9	STS-R0		
						6.1	FDC-06107-**	5.0	STS8-□5.0	STS-R0		
						6.2	FDC-06207-**	5.0	STS8-□5.0	STS-R0		
STM12	M4-M4.5	UNo.8		M4-M6	M6	5.0	FSC-09-5.0-**	4.0	STS12-□4.0	STS-R1		
	M5-M5.5	UNo.10-12				5.5	FSC-09-5.5-**	4.5	STS12-□4.5	STS-R1		
	M6	U1/4				6.0	FSC-09-6.0-**	4.5	STS12-□4.5	STS-R1		
						6.0	FSC-09-6.0-**	4.9	STS12-□4.9	STS-R1		
						6.1	FSC-09-6.1-**	5.0	STS12-□5.0	STS-R1		
						6.2	FSC-09-6.2-**	5.0	STS12-□5.0	STS-R1		
	M7-8					7.0	FSC-09-7.0-**	5.5	STS12-□5.5	STS-R1		
	M9-M10	U3/8				8.0	FSC-09-8.0-**	6.2	STS12-□6.2	STS-R1		
	M11	U7/16	PT1/16-1/8			M8-M10	M8	8.0	FSC-09-8.0-**	6.0	STS12-□6.0	STS-R1
	M12							8.5	FSC-09-8.5-**	6.5	STS12-□6.5	STS-R1
STM18		U1/2				9.0	FSC-16-9.0-**	7.0	STS18-□7.0	STS-R2		
	M13			M12	M10	9.5	FSC-16-9.5-**	7.0	STS18-□7.0	STS-R2		
						10.0	FSC-16-10.0-**	8.0	STS18-□8.0	STS-R2		
	M14-15	U9/16				10.5	FSC-16-10.5-**	8.0	STS18-□8.0	STS-R2		
			PT1/4			11.0	FSC-16-11.0-**	9.0	STS18-□9.0	STS-R2		
				M14	M12	12.0	FSC-16-12.0-**	9.0	STS18-□9.0	STS-R2		
	M16					12.5	FSC-16-12.5-**	10.0	STS18-□10.0	STS-R2		
	M17					13.0	FSC-16-13.0-**	10.0	STS18-□10.0	STS-R2		
	M18-M19	U3/4	PT3/8			14.0	FSC-16-14.0-**	11.0	STS18-□11.0	STS-R2		
						15.0	FSC-22-15.0-**	12.0	STS30-□12.0	STS-R2		
STM30	M20			M16-M20		16.0	FSC-22-16.0-**	12.0	STS30-□12.0	STS-R2		
	M21					17.0	FSC-22-17.0-**	13.0	STS30-□13.0	STS-R2		
	M22	U7/8				18.0	FSC-22-18.0-**	14.0	STS30-□14.0	STS-R2		
	M23		PT1/2			19.0	FSC-22-19.0-**	15.0	STS30-□15.0	STS-R2		
	M24-M25		PT5/8			20.0	FSC-22-20.0-**	15.0	STS30-□15.0	STS-R2		
	M26-M27	U1		M22-M27		21.0	FSC-22-21.0-**	17.0	STS30-□17.0	STS-R2		
	M28					22.0	FSC-22-22.0-**	17.0	STS30-□17.0	STS-R2		
		U1-1/8				23.0	FSC-22-23.0-**	17.0	STS30-□17.0	STS-R2		
	M30		PT3/4									

Ejemplo para Ordenar - Ordering Example

FSC - 22 - 20.0 - OH

Medida de la boquilla
 Collet size

D.I. de la boquilla
 Collet I.D. (d)

OH:Para herramienta con vena de lubricación

C:Para refrigeración a través de los costados de la boquilla

OH:For tool with coolant hole

C:For collet through

Combinación de accesorios - Accessories combination

Portaherramienta para machuelo - Tap holder	Boquilla Collet	Conductor de preajuste Preset Driver		Tuerca ciega Nut		Unidad de cambio de herramienta Tool changing driver		Llave Inglesa Spanner	
Modelo Model	Modelo Model	Modelo Model	Código Code	Modelo Model	Código Code	Modelo Model	Código Code	Modelo Model	Código Code
STM8	FDC-07	STS8	3914 0100**03	KDP-1414	0070 01001407	STS-R0	3914 00000006	Llave con 17 mm de ancho (Flat 17mm width)	
STM12	FSC-09	STS12	3914 1100**03	HTP-09	1314 00000009	STS-R1	3914 10000006	S-1L	0803 00000011
STM18	FSC-16	STS18	3914 310***03	HTP-16	1314 00000016	STS-R2	3914 30000006	S-4L	0803 00000014
STM30	FSC-22	STS30	3914 410***03	HTP-22	1314 00000022	STS-R2	3914 30000006	S-5L	0803 00000015

FSC-OH

Para herramienta con orificio para refrigerante
For tool with coolant hole

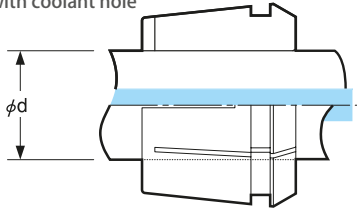

Diá. del zanco de la herramienta - Tool Shank Dia.		Medida Size	Código Code
ød (inch)	ød (mm)		
ø 0.141	ø 3.6	FSC-09-3.6-OH	—
ø 0.168	ø 4.3	FSC-09-4.3-OH	1334 00104309
ø 0.194	ø 5.0	FSC-09-5.0-OH	1334 00105009
ø 0.220	ø 5.6	FSC-09-5.6-OH	1334 00105609
ø 0.216	ø 5.5	FSC-09-5.5-OH	1334 00105509
ø 0.236	ø 6.0	FSC-09-6.0-OH	1334 00106009
ø 0.240	ø 6.1	FSC-09-6.1-OH	1334 00106109
ø 0.244	ø 6.2	FSC-09-6.2-OH	1334 00106209
ø 0.255	ø 6.5	FSC-09-6.5-OH	1334 00106509
ø 0.275	ø 7.0	FSC-09-7.0-OH	1334 00107009
ø 0.314	ø 8.0	FSC-09-8.0-OH	1334 00108009
ø 0.313	ø 8.0	FSC-09-8.0-OH	1334 00108009
ø 0.318	ø 8.1	FSC-09-8.1-OH	1334 00108109
ø 0.323	ø 8.3	FSC-09-8.3-OH	1334 00108309
ø 0.334	ø 8.5	FSC-09-8.5-OH	1334 00108509
ø 0.354	ø 9.0	FSC-16-9.0-OH	1334 00109016
ø 0.367	ø 9.4	FSC-16-9.4-OH	1334 00109416
ø 0.374	ø 9.5	FSC-16-9.5-OH	1334 00109516
ø 0.381	ø 9.7	FSC-16-9.7-OH	1334 00109716
ø 0.393	ø 10.0	FSC-16-10.0-OH	1334 00110016
ø 0.413	ø 10.5	FSC-16-10.5-OH	1334 00110516
ø 0.429	ø 10.9	FSC-16-10.9-OH	1334 00110916
ø 0.433	ø 11.0	FSC-16-11.0-OH	1334 00111016
ø 0.437	ø 11.1	FSC-16-11.1-OH	1334 00111116
ø 0.472	ø 12.0	FSC-16-12.0-OH	1334 00112016
ø 0.480	ø 12.2	FSC-16-12.2-OH	1334 00112216
ø 0.492	ø 12.5	FSC-16-12.5-OH	1334 00112516
ø 0.511	ø 13.0	FSC-16-13.0-OH	1334 00113016
ø 0.542	ø 13.8	FSC-16-13.8-OH	1334 00113816
ø 0.551	ø 14.0	FSC-16-14.0-OH	1334 00114016
ø 0.562	ø 14.3	FSC-16-14.3-OH	1334 00114316
ø 0.590	ø 15.0	FSC-22-15.0-OH	1334 00115022
ø 0.629	ø 16.0	FSC-22-16.0-OH	1334 00116022
ø 0.652	ø 16.6	FSC-22-16.6-OH	1334 00116622
ø 0.669	ø 17.0	FSC-22-17.0-OH	1334 00117022
ø 0.697	ø 17.8	FSC-22-17.8-OH	1334 00117822
ø 0.700	ø 17.8	FSC-22-17.8-OH	1334 00117822
ø 0.708	ø 18.0	FSC-22-18.0-OH	1334 00118022
ø 0.748	ø 19.0	FSC-22-19.0-OH	1334 00119022
ø 0.800	ø 20.4	FSC-22-20.4-OH	1334 00120422
ø 0.787	ø 20.0	FSC-22-20.0-OH	1334 00120022
ø 0.826	ø 21.0	FSC-22-21.0-OH	1334 00121022
ø 0.866	ø 22.0	FSC-22-22.0-OH	1334 00122022
ø 0.905	ø 23.0	FSC-22-23.0-OH	1334 00123022

FSC-C

Para refrigerante a través de la boquilla
For Collet through

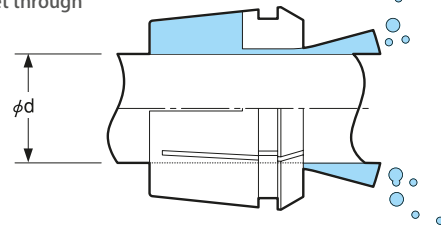

Diá. del zanco de la herramienta - Tool Shank Dia.		Medida Size	Código Code
ød (inch)	ød (mm)		
ø 0.141	ø 3.6	FSC-09-3.6-C	—
ø 0.168	ø 4.3	FSC-09-4.3-C	1335 00104309
ø 0.194	ø 5.0	FSC-09-5.0-C	1335 00105009
ø 0.220	ø 5.6	FSC-09-5.6-C	1335 00105609
ø 0.216	ø 5.5	FSC-09-5.5-C	1335 00105509
ø 0.236	ø 6.0	FSC-09-6.0-C	1335 00106009
ø 0.240	ø 6.1	FSC-09-6.1-C	1335 00106109
ø 0.244	ø 6.2	FSC-09-6.2-C	1335 00106209
ø 0.255	ø 6.5	FSC-09-6.5-C	1335 00106509
ø 0.275	ø 7.0	FSC-09-7.0-C	1335 00107009
ø 0.314	ø 8.0	FSC-09-8.0-C	1335 00108009
ø 0.313	ø 8.0	FSC-09-8.0-C	1335 00108009
ø 0.318	ø 8.1	FSC-09-8.1-C	1335 00108109
ø 0.323	ø 8.3	FSC-09-8.3-C	1335 00108309
ø 0.334	ø 8.5	FSC-09-8.5-C	1335 00108509
ø 0.354	ø 9.0	FSC-16-9.0-C	1335 00109016
ø 0.367	ø 9.4	FSC-16-9.4-C	1335 00109416
ø 0.374	ø 9.5	FSC-16-9.5-C	1335 00109516
ø 0.381	ø 9.7	FSC-16-9.7-C	1335 00109716
ø 0.393	ø 10.0	FSC-16-10.0-C	1335 00110016
ø 0.413	ø 10.5	FSC-16-10.5-C	1335 00110516
ø 0.429	ø 10.9	FSC-16-10.9-C	1335 00110916
ø 0.433	ø 11.0	FSC-16-11.0-C	1335 00111016
ø 0.437	ø 11.1	FSC-16-11.1-C	1335 00111116
ø 0.472	ø 12.0	FSC-16-12.0-C	1335 00112016
ø 0.480	ø 12.2	FSC-16-12.2-C	1335 00112216
ø 0.492	ø 12.5	FSC-16-12.5-C	1335 00112516
ø 0.511	ø 13.0	FSC-16-13.0-C	1335 00113016
ø 0.542	ø 13.8	FSC-16-13.8-C	1335 00113816
ø 0.551	ø 14.0	FSC-16-14.0-C	1335 00114016
ø 0.562	ø 14.3	FSC-16-14.3-C	1335 00114316
ø 0.590	ø 15.0	FSC-22-15.0-C	1335 00115022
ø 0.629	ø 16.0	FSC-22-16.0-C	1335 00116022
ø 0.652	ø 16.6	FSC-22-16.6-C	1335 00116622
ø 0.669	ø 17.0	FSC-22-17.0-C	1335 00117022
ø 0.697	ø 17.8	FSC-22-17.8-C	1335 00117822
ø 0.700	ø 17.8	FSC-22-17.8-C	1335 00117822
ø 0.708	ø 18.0	FSC-22-18.0-C	1335 00118022
ø 0.748	ø 19.0	FSC-22-19.0-C	1335 00119022
ø 0.800	ø 20.4	FSC-22-20.4-C	1335 00120422
ø 0.787	ø 20.0	FSC-22-20.0-C	1335 00120022
ø 0.826	ø 21.0	FSC-22-21.0-C	1335 00121022
ø 0.866	ø 22.0	FSC-22-22.0-C	1335 00122022
ø 0.905	ø 23.0	FSC-22-23.0-C	1335 00123022

Se deberá elegir el tipo OH en caso de que no se use el refrigerante desde el husillo de la máquina.
OH type shall be selected in case not utilizing coolant through from the machine spindle.

Ejemplo para Ordenar - Ordering Example

FSC - 16 - 9.0 - OH
Series 16 Diá. del zanco de la herramienta
16 Series Tool Shank Dia.

Ejemplo para Ordenar - Ordering Example

FSC - 16 - 9.0 - C
Series 16 Diá. del zanco de la herramienta
16 Series Tool Shank Dia.

Face Mill Arbor (For Cutters With Oil Hole)

- El refrigerante fluye del refrentado de la locación central al cortador con el orificio para aceite.
- Coolant flows from the end face of centering location to cutter with oil hole.

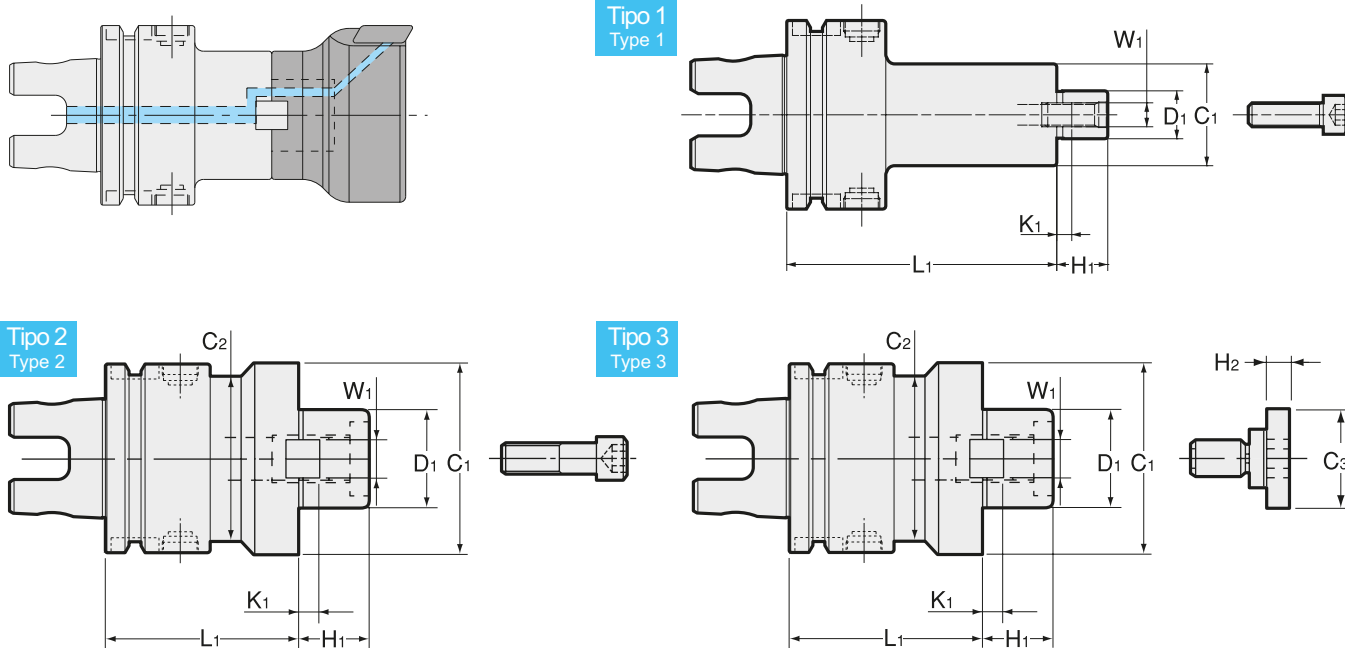

Medidas Métricas - Metric Sizes

Unidad : Métrico
Unit : Metric

Código Code	Modelo Model	Tipo Type	D1 (h6)	L1	C1	C2	H1	W1	K1	C3	H2	—	El perno de sujeción Clamp Bolt
1320 51116060	UTS5040 -FMH16A -34 -60-H	1	16	60	34	—	17	8	5	—	—	26,730	M8
1320 51122060	-FMH22A -47 -60-H	1	22	60	47	—	18	10	5	—	—	26,730	M10
1320 51123060	-FMH22.225A -47 -60-H	1	22.225	60	47	—	17	8	3.5	—	—	26,730	M12
1320 51125060	-FMH25.4A -60 -60-H	2	25.4	60	60	50	22	9.5	5	—	—	26,950	M12
1320 51127060	-FMH27A -60 -60-H	2	27	60	60	50	20	12	6	—	—	26,950	M12
1320 5*216060	UTS6350 -FMH16A -34 -60	1	16	60	34	—	17	8	5	—	—	26,730	M8
1320 5*216090	-90	1	16	90	34	—	17	8	5	—	—	26,730	M8
1320 5*216120	-120	1	16	120	34	—	17	8	5	—	—	26,950	M8
1320 5*222060	-FMH22A -47 -60	1	22	60	47	—	18	10	5	—	—	26,730	M10
1320 5*222090	-90	1	22	90	47	—	18	10	5	—	—	26,950	M10
1320 5*222120	-120	1	22	120	47	—	18	10	5	—	—	27,390	M10
1320 5*222060	-60 -60	1	22	60	60	—	18	10	5	—	—	26,730	M10
1320 5*222090	-90	1	22	90	60	—	18	10	5	—	—	26,950	M10
1320 5*222120	-120	1	22	120	60	—	18	10	5	—	—	27,390	M10
1320 5*223060	-FMH22.225A -47 -60	1	22.225	60	47	—	17	8	3.5	—	—	26,730	M10
1320 5*223090	-90	1	22.225	90	47	—	17	8	3.5	—	—	26,950	M10
1320 5*223120	-120	1	22.225	120	47	—	17	8	3.5	—	—	27,390	M10
1320 5*223060	-60 -60	1	22.225	60	60	—	17	8	3.5	—	—	26,730	M10
1320 5*223090	-90	1	22.225	90	60	—	17	8	3.5	—	—	26,950	M10
1320 5*223120	-120	1	22.225	120	60	—	17	8	3.5	—	—	27,390	M10
1320 5*225060	-FMH25.4A -60 -60	1	25.4	60	60	—	22	9.5	5	—	—	32,230	M12
1320 5*225090	-90	1	25.4	90	60	—	22	9.5	5	—	—	32,670	M12
1320 5*225120	-120	1	25.4	120	60	—	22	9.5	5	—	—	32,670	M12
1320 5*227060	-FMH27A -60 -60	1	27	60	60	—	20	12	6	—	—	32,230	M12
1320 5*227090	-90	1	27	90	60	—	20	12	6	—	—	32,670	M12
1320 5*227120	-120	1	27	120	60	—	20	12	6	—	—	32,670	M12
1320 5*227060	-76 -60	2	27	60	76	63	20	12	6	—	—	32,230	M12
1320 5*227090	-90	2	27	90	76	63	20	12	6	—	—	32,670	M12
1320 5*227120	-120	2	27	120	76	63	20	12	6	—	—	32,670	M12
1320 5*231060	-FMH31.75A -76 -60	2	31.75	60	76	63	30	12.7	7	—	—	32,230	M16
1320 5*231090	-90	2	31.75	90	76	63	30	12.7	7	—	—	32,670	M16
1320 5*231120	-120	2	31.75	120	76	63	30	12.7	7	—	—	32,670	M16
1320 5*231060	-96 -60	2	31.75	60	96	63	30	12.7	7	—	—	32,230	M16
1320 5*231090	-90	2	31.75	90	96	63	30	12.7	7	—	—	32,670	M16
1320 5*231120	-120	2	31.75	120	96	63	30	12.7	7	—	—	32,670	M16
1320 5*232060	-FMH32A -96 -60	2	32	60	96	63	22	14	7	—	—	32,230	M16
1320 5*232090	-90	2	32	90	96	63	22	14	7	—	—	32,670	M16
1320 5*232120	-120	2	32	120	96	63	22	14	7	—	—	32,670	M16

Medidas Métricas - Metric Sizes

Unidad : Métrico
Unit : Metric

Código Code	Modelo Model	Tipo Type	D1 (h6)	L1	C1	C2	H1	W1	K1	C3	H2	—	El perno de sujeción Clamp Bolt	
1320 5**316075	UTS10080 -FMH16A	-34 -75	1	16	75	34	—	17	8	5	—	44,770	M8	
1320 5**316105		-105	1	16	105	34	—	17	8	5	—	45,100		
1320 5**316135		-135	1	16	135	34	—	17	8	5	—	45,760		
1320 5**322075	-FMH22A	-47 -75	1	22	75	47	—	18	10	5	—	45,760	M10	
1320 5**322105		-105	1	22	105	47	—	18	10	5	—	46,200		
1320 5**322135		-135	1	22	135	47	—	18	10	5	—	46,750		
1320 5**322075		-60 -75	1	22	75	60	—	18	10	5	—	45,760		
1320 5**322105		-105	1	22	105	60	—	18	10	5	—	46,200		
1320 5**322135		-135	1	22	135	60	—	18	10	5	—	46,750		
1320 5**323075	-FMH22.225A	-47 -75	1	22.225	75	47	—	17	8	3.5	—	45,760	M10	
1320 5**323105		-105	1	22.225	105	47	—	17	8	3.5	—	46,200		
1320 5**323135		-135	1	22.225	135	47	—	17	8	3.5	—	46,750		
1320 5**323075		-60 -75	1	22.225	75	60	—	17	8	3.5	—	45,760		
1320 5**323105		-105	1	22.225	105	60	—	17	8	3.5	—	46,200		
1320 5**323135		-135	1	22.225	135	60	—	17	8	3.5	—	46,750		
1320 5**325075	-FMH25.4A	-60 -75	1	25.4	75	60	—	22	9.5	5	—	45,760	M12	
1320 5**325105		-105	1	25.4	105	60	—	22	9.5	5	—	46,200		
1320 5**325135		-135	1	25.4	135	60	—	22	9.5	5	—	46,750		
1320 5**327075	-FMH27A	-60 -75	1	27	75	60	—	20	12	6	—	45,760		
1320 5**327105		-105	1	27	105	60	—	20	12	6	—	46,200		
1320 5**327135		-135	1	27	135	60	—	20	12	6	—	46,750		
1320 5**327075		-76 -75	1	27	75	76	—	20	12	6	—	45,760	M16	
1320 5**327105		-105	1	27	105	76	—	20	12	6	—	46,200		
1320 5**327135		-135	1	27	135	76	—	20	12	6	—	46,750		
1320 5**331075	-FMH31.75A	-76 -75	1	31.75	75	76	—	30	12.7	7	—	45,760		
1320 5**331105		-105	1	31.75	105	76	—	30	12.7	7	—	46,200		
1320 5**331135		-135	1	31.75	135	76	—	30	12.7	7	—	46,750		
1320 5**331075		-96 -75	1	31.75	75	96	—	30	12.7	7	—	45,760	M16	
1320 5**331105		-105	1	31.75	105	96	—	30	12.7	7	—	46,200		
1320 5**331135		-135	1	31.75	135	96	—	30	12.7	7	—	46,750		
1320 5**332075	-FMH32A	-96 -75	1	32	75	96	—	22	14	7	—	45,760		
1320 5**332105		-105	1	32	105	96	—	22	14	7	—	46,200		
1320 5**332135		-135	1	32	135	96	—	22	14	7	—	46,750		
1320 5**338075	-FMH38.1A	-80 -75	3	38.1	75	80	80	34	15.9	9	50	14	45,760	MBAH-M20
1320 5**338105		-105	3	38.1	105	80	80	34	15.9	9	50	14	46,200	
1320 5**338135		-135	3	38.1	135	80	80	34	15.9	9	50	14	46,750	
1320 5**338075		-100 -75	3	38.1	75	100	100	34	15.9	9	50	14	45,760	
1320 5**338105		-105	3	38.1	105	100	100	34	15.9	9	50	14	46,200	
1320 5**338135		-135	3	38.1	135	100	100	34	15.9	9	50	14	46,750	
1320 5**340075	-FMH40A	-100 -75	3	40	75	100	100	26	16	8.5	50	14	45,760	MBAH-M20
1320 5**340105		-105	3	40	105	100	100	26	16	8.5	50	14	46,200	
1320 5**340135		-135	3	40	135	100	100	26	16	8.5	50	14	46,750	
1320 5**350075	-FMH50.8A	-100 -75	3	50.8	75	100	100	36	19.05	10	65	14	45,760	
1320 5**350105		-105	3	50.8	105	100	100	36	19.05	10	65	14	46,200	
1320 5**350135		-135	3	50.8	135	100	100	36	19.05	10	65	14	46,750	

Al hacer su orden, favor de especificar entre presión alta o baja. Para el tipo de presión alta, favor de agregar (-H) al final de la descripción.

- El UTS5040 sólo está disponible en presión alta.
- Incluye el perno de sujeción.

When placing an order, please specify high or low pressure. For high pressure type, please add (-H) on end of the description.

- UTS5040 is available in high pressure only.
- Clamp bolt is included.

Ejemplo para Ordenar - Ordering Example

Tipo de baja presión - Low pressure type

0 ~ 1.0MPa (UTS10080 : 0 ~ 2.0MPa)

UTS6350 - FMH 25.4A - 60 - 60

Interfaz y diámetro de husillo	D1	C1	Longitud de proyección
Shank size	D1	C1	Projection length

Ejemplo para Ordenar - Ordering Example

Tipo de alta presión - High pressure type

1.1 ~ 7.0MPa (UTS10080 : 2.1 ~ 7.0MPa)

UTS6350 - FMH 25.4A - 60 - 60 - H

Interfaz y diámetro de husillo	D1	C1	Longitud de proyección	Tipo de alta presión
Shank size	D1	C1	Projection length	High pressure type

Face Mill Arbor

- Para fresa JIS B4113.
- For JIS B4113 face mill.

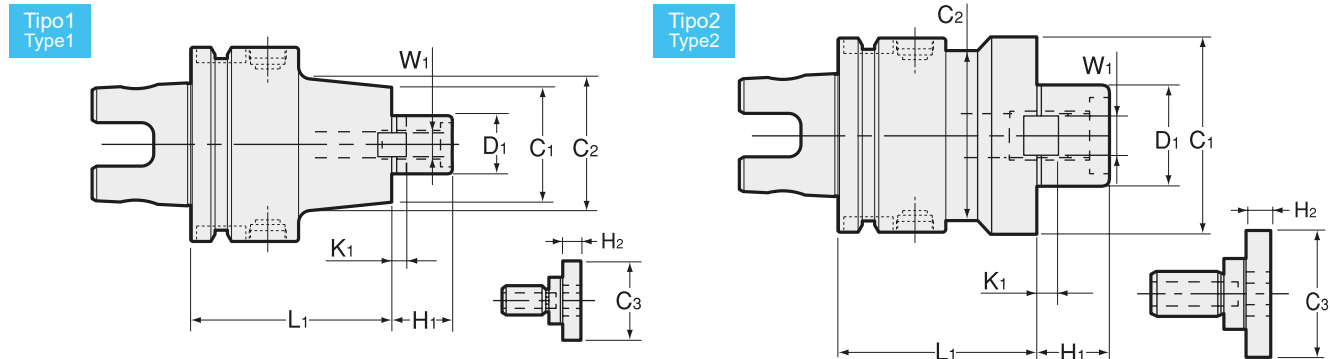

Medidas Métricas - Metric Sizes

Unidad : Métrico
Unit : Metric

Código Code	Modelo Model	Tipo Type	D1	L1	H1	C1	C2	W1	K1	C3	H2	—	El perno de sujeción Clamp Bolt	Ejemplo del diámetro de cortador Cutter dia. Example
1320 41125060	UTS5040 -FMA25.4A -60-H	1	25.4	60	22	50	50	9.5	5	33	10	22,000	MBA-M12	75
1320 4 ※ 225060	UTS6350 -FMA25.4A -60	1	25.4	60	22	50	50	9.5	5	33	10	25,300	MBA-M12	75
1320 4 ※ 225090	-90	1	25.4	90	22	50	50	9.5	5	33	10	26,620		
1320 4 ※ 225120	-120	1	25.4	120	22	50	50	9.5	5	33	10	26,620		
1320 4 ※ 231060	-FMA31.75A -60	1	31.75	60	30	60	60	12.7	7	40	10	25,300	MBA-M16	100
1320 4 ※ 231090	-90	1	31.75	90	30	60	60	12.7	7	40	10	26,620		
1320 4 ※ 231120	-120	1	31.75	120	30	60	60	12.7	7	40	10	26,620		
1320 4 ※ 238060	-FMA38.1A -60	2	38.1	60	34	80	63	15.9	9	50	14	29,150	MBA-M20	125
1320 4 ※ 238090	-90	2	38.1	90	34	80	63	15.9	9	50	14	30,360		
1320 4 ※ 238120	-120	2	38.1	120	34	80	63	15.9	9	50	14	30,360		
1320 4 ※ 325075	UTS10080 -FMA25.4A -75	1	25.4	75	22	50	85	9.5	5	33	10	36,740	MBA-M12	75
1320 4 ※ 325105	-105	1	25.4	105	22	50	85	9.5	5	33	10	39,270		
1320 4 ※ 325135	-135	1	25.4	135	22	50	85	9.5	5	33	10	41,690		
1320 4 ※ 331075	-FMA31.75A -75	1	31.75	75	30	60	85	12.7	7	40	10	36,740	MBA-M16	100
1320 4 ※ 331105	-105	1	31.75	105	30	60	85	12.7	7	40	10	39,270		
1320 4 ※ 331135	-135	1	31.75	135	30	60	85	12.7	7	40	10	41,690		
1320 4 ※ 338075	-FMA38.1A -75	1	38.1	75	34	80	85	15.9	9	50	14	36,740	MBA-M20	125
1320 4 ※ 338105	-105	1	38.1	105	34	80	85	15.9	9	50	14	39,270		
1320 4 ※ 338135	-135	1	38.1	135	34	80	85	15.9	9	50	14	41,690		
1320 4 ※ 350075	-FMA50.8A -75	1	50.8	75	36	99	99	19.05	10	65	14	36,740	MBA-M24	150
1320 4 ※ 350105	-105	1	50.8	105	36	99	99	19.05	10	65	14	39,270		
1320 4 ※ 350135	-135	1	50.8	135	36	99	99	19.05	10	65	14	41,690		

Al hacer su orden, favor de especificar entre presión alta o baja. Para el tipo de presión alta, favor de agregar (-H) al final de la descripción.

1. El UTS5040 sólo está disponible en presión alta.
2. Incluye el perno de sujeción.

When placing an order, please specify high or low pressure. For high pressure type, please add (-H) on end of the description.

1. UTS5040 is available in high pressure only.
2. Clamp bolt is included.

Ejemplo para Ordenar - Ordering Example

Tipo de baja presión - Low pressure type
0 ~ 1.0MPa (UTS10080 : 0 ~ 2.0MPa)

UTS6350 - FMA 25.4 - 60

Interfaz y diámetro de husillo
Shank size

D1 L1
D1 L1

Ejemplo para Ordenar - Ordering Example

Tipo de alta presión - High pressure type
1.1 ~ 7.0MPa (UTS10080 : 2.1 ~ 7.0MPa)

UTS6350 - FMA 25.4 - 60 - H

Interfaz y diámetro de husillo
Shank size

D1 L1
D1 L1

Tipo de alta presión
High pressure type

BT
CAT
AHO
HSK-A/E/F/C
HSK-T
C
UTS
Máquinas Especializadas
Specialized Machine
Equipo Relacionado
Related Equipment
Taladro de Biselado & de Casquillo
Bush & Chamfering Drill
Milling Chuck
Collet Holder
"R" Zero Holder
Hydraulic Chuck
Shrink Fit
Tapping Chuck
Arbors

Dimensiones para el zanco tipo UTS

Tool Shank Dimensions For UTS

Zanco UTS / UTS shank

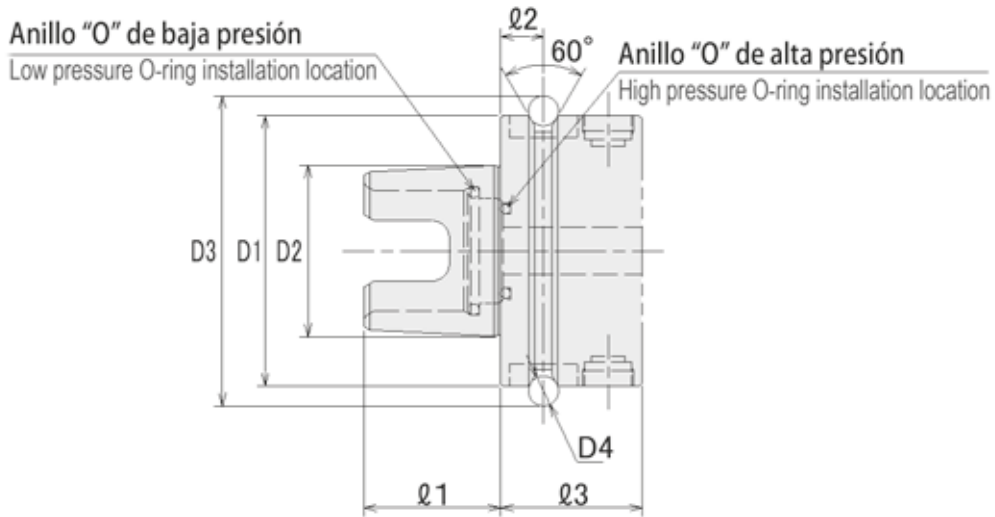

Medida de zanco Shank size	D1	D2	D3	D4	l1	l2	l3	Medida de anillo "O" O-ring size
UTS5040-H	50	30	59.4	7	25	9	30	-
UTS6350	63	40	72.4	7	32	9.9	33	AS568120 4D-HS90
UTS6350-H	63	40	72.4	7	32	9.9	33	-
UTS10080	100	64	109.4	7	45	11	34	AS568224 4D-HS90
UTS10080-H	100	64	109.4	7	45	11	34	-

1. "-H" indica que el modelo es de alta presión. Si el "H" no está incluido, entonces el modelo es de baja presión.

2. Al intercambiar el anillo "O", por favor contacte a NT TOOL para colocar la orden.

1. "-H" indicates the high-pressure type. If "H" is not included, then it is the low-pressure type.

2. When switching O-rings, please contact NT Tool to place an order.

BT
CAT
AHO
HSK-A/E/F/C
HSK-T
C

UTS

Máquinas
Especializadas
Specialized
Machine

Equipo
Relacionado
Related
Equipment

Taladro de
Biselado & de
Casquillo
Bush &
Chamfering
Drill

Milling Chuck

Collet Holder

"R" Zero Holder

Hydraulic
Chuck

Shrink Fit

Tapping Chuck

Anvils

**SISTEMAS DE HERRAMENTADO
DE LA SERIE DE MÁQUINAS
ESPECIALIZADAS**

SPECIALIZED MACHINE SERIES TOOLING SYSTEM

Portaherramienta de zanco recto para cambio rápido

Quick Change Stub Holder

Aplicación

Application

- Portaherramienta para barrenado y rimado. Acabado en fresa posible con el KH-E
Stub drilling and reaming. Endmilling possible with KH-E
- Para máquinas con propósitos especiales, líneas de transferencia, etcétera.
For special purpose machines, transfer lines etc.

Característica

Feature

El maquinado sin casquillos/guías
Bushingless machining

El uso de portaherramientas de zanco recto para perforación incrementa la rigidez.
Use of short stub drills increases rigidity.

Diseño de maquinado simple
Simple machine design

El maquinado sin casquillos reduce el costo del diseño y la fabricación de la máquina.
Bushingless machining reduce cost for machine design and manufacturing.

Reducción en el costo de la herramienta
Reduction of tool cost

La perforación con portaherramientas de zanco recto ofrece mucha rigidez y una larga vida de la herramienta.
Stub drills offer high rigidity and long tool life.

Fácil eliminación de las virutas
Easy disposal of chips

El diseño sencillo del portaherramienta de zanco recto permite quitar la viruta con facilidad.
The simple stub holder design allows for easy chip removal.

Agarre seguro de la broca
Secure gripping of drill

Las boquillas de alta precisión de NT garantizan una gran fuerza de agarre y una ubicación precisa de orificios.
NT's high precision collets assures maximum gripping power and precise hole location.

Disminución en el tiempo de preparación
Reduction of preparation time

Es sencillo insertar / extraer los portaherramientas de zanco recto con una sola mano.
La longitud de proyección de los portaherramientas de zanco recto puede ajustarse con el tornillo de preajuste.
Insertion / removal of the stub holders is easily achieved by a single hand operation.
The projection length of stub drill can be adjusted by the preset screw.

Inoxidable

No Rust

Tratamiento de superficie especial

- Libre de óxido bajo las condiciones normales de uso.
No hay pérdida de precisión a causa del óxido.
- Requiere de poco mantenimiento

Special Surface Treatment

- Rust-free under normal use conditions. No loss of precision due to rust.
- Minimum maintenance required.

Portaherramienta de zanco recto
Stub Holder
KH-E
KH-EC1



Portaherramienta de zanco recto
Stub Holder
KH-A
KH



Problemas con el estilo antiguo de barrenado

Problems with Old Style Drilling

- Los portaherramientas viejos suelen oxidarse con rapidez y requieren de mantenimiento.
Old holders tend to get rusty quickly, and require maintenance.
- Se necesita tener casquillos debido a la baja rigidez del taladro y del husillo.
Bushings are required due to low rigidity of drill and spindle.
- Usar casquillos y placas con escobillas limitan la eliminación de virutas. Se requiere de más tiempo para diseñar la máquina.
The use of bushings and bush plates limits chip disposal. Longer time is needed for machine design.
- Se requiere de taladros con zancos MT costosos para garantizar una buena precisión en el agarre.
Expensive MT shank drills are required to secure high gripping accuracy.
- Toma más tiempo reemplazar las herramientas.
It takes a longer to replace the tools.
- Las proyecciones largas de perforación reducen la precisión.
Longer drill projections reduces accuracy.

BT
CAT
AHO
HSK-A/E/F/C
HSK-T
C
UTS
Sistemas de
herramientado
de la serie
de máquinas
especializadas
Specialized
Machine
Equipo
Relacionado
Related
Equipment
Casquillos guía
y taladro de
biselado
Bush &
Chamfering
Drill

Stub Holder

Tapping Chuck

Tap Adapter

Adjustable
Adapter

Endmill Chuck

Straight Drill
Chuck

Floating Holder

KH-E

Quick Change Stub Holder

Características

Features

El acabado en fresa, algo que previamente no era disponible, ahora es posible.
Endmilling, which was not available before, becomes possible.

Alta rigidez

High Rigidity

Debido a la función de bloqueo incorporada, el portaherramienta no se sale del husillo, a pesar de las fuerzas de tracción.
Owing to the locking function incorporated, the holder doesn't come off spindle even though drawing force works.

Alta precisión

High Precision

Mientras se usa la boquilla de alta precisión, la excentricidad está disponible dentro de 10 micras en 4 x D (4X diá. del zanco de la herramienta. Distancia desde una punta del portaherramienta).

As the high precision collet is employed, the runout is available within 10 microns at 4 x D (4X tool shank dia. Distance from the holder nose).

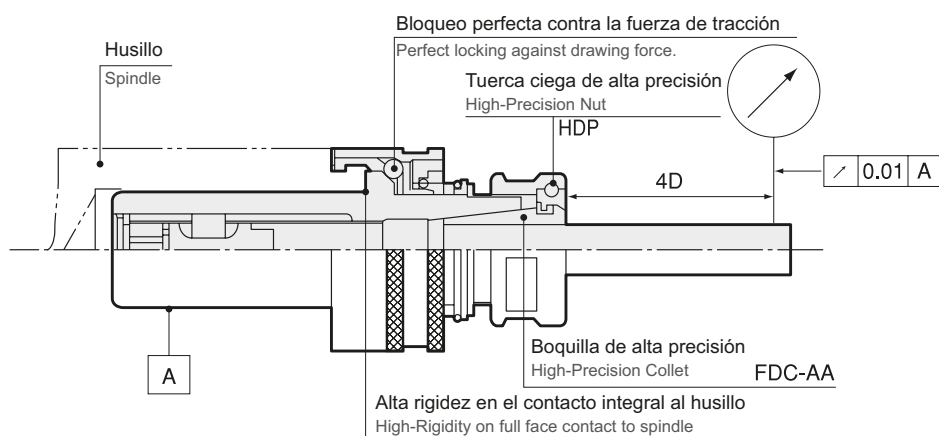

Diferencia significativa entre el portaherramienta de zanco recto KH-E y otros

Significant Difference between KH-E and other stub holders

El maquinado fuerte previene que la herramienta de corte se desprenda.
Strong chucking prevents pull out of cutting tool.

EL mecanismo de bloqueo detiene a la fuerza de extracción de las herramientas de corte espirales, como del acabado en fresa.

Locking mechanism stops pulling force caused by spiral cutting tools such as end mill.

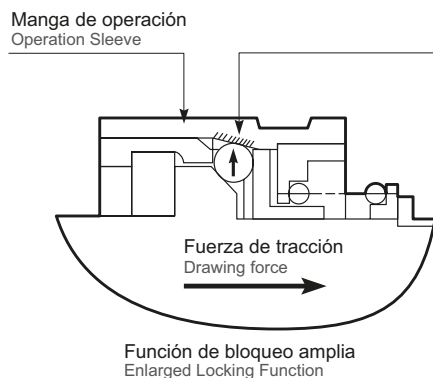

El zanco cónico con paso bajo en la funda de operación no permiten que el portaherramienta se desprenda gracias a las esferas de acero, que se mueven en dirección radial, por la fuerza de tracción están adheridas al zanco.

Low-pitched taper on operation sleeve does not allow the holder to come off because steel balls which move to radial direction by drawing force are stuck on the taper.

Nota

- Para el suministro de refrigerante a través del centro, elija los modelos KH-EC1 o KH-EC2 en la página 454 - 455.
For center-thru coolant feed, select KH-EC1 OR KH-EC2 models on page 454 - 455.

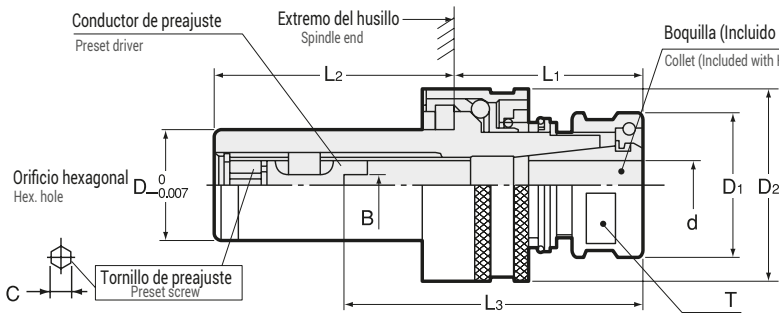

KH-E Conjunto de boquilla - Collet set

Portaherramienta Holder + Conductor de preajuste Preset Driver + Tuerca ciega Nut + Boquilla Collet

Código Code	Modelo Model	D	B	d Rango de sujeción Chucking range d	Conductor de preajuste Preset Driver	L3	D1	D2	L1	L2	C	kg	Boquilla Collet	Tuerca ciega Nut	Llave Inglesa Spanner
3050 12 # # # * * * *	KH-12E	12	0	0.5 ~ 6.0	KHS -00006	20 ~ 45	23	24.3	34	35	3	0.1	FDC-d07AA	HDP-07A	S-0
			2.4	3.1 ~ 5.0	KHS -02406	24 ~ 48									
			3.0	5.1 ~ 6.0	KHS -03006	25 ~ 48									
3050 14 # # # * * * *	KH-14E	14	0	0.5 ~ 7.0	KHS -00007	20 ~ 45	23	26.3	34	35	4	0.1	FDC-d07AA	HDP-07A	S-0
			2.4	3.1 ~ 5.0	KHS -02407	24 ~ 48									
			3.0	5.1 ~ 6.0	KHS -03007	25 ~ 48									
3050 16 # # # * * * *	KH-16E	16	0	2.6 ~ 9.0	KHS -00009	29 ~ 46	26	32	35	40	4	0.2	FDC-d09AA	HDP-09	S-1L
			2.4	3.1 ~ 5.0	KHS -02409	32 ~ 49									
			3.0	5.1 ~ 6.0	KHS -03009	34 ~ 51									
3050 19 # # # * * * *	KH-19E	19	0	2.6 ~ 9.0	KHS -00009	29 ~ 51	26	35	35	45	4	0.2	FDC-d09AA	HDP-09	S-1L
			2.4	3.1 ~ 5.0	KHS -02409	32 ~ 54									
			3.0	5.1 ~ 6.0	KHS -03009	34 ~ 56									
3050 20 # # # * * * *	KH-20E	20	0	2.6 ~ 9.0	KHS -00009	29 ~ 51	26	35	35	45	4	0.2	FDC-d09AA	HDP-09	S-1L
			2.4	3.1 ~ 5.0	KHS -02409	32 ~ 54									
			3.0	5.1 ~ 6.0	KHS -03009	34 ~ 56									
3050 22 # # # * * * *	KH-22E	22	0	2.6 ~ 12.0	KHS -00012	35 ~ 62	32	38	35	55	5	0.3	FDC-d12AA	HDP-12	S-3L
			2.4	3.1 ~ 5.0	KHS -02412	33 ~ 60									
			3.0	5.1 ~ 6.0	KHS -03012	33 ~ 60									
3050 24 # # # * * * *	KH-24E	24	0	2.6 ~ 12.0	KHS -00012	35 ~ 62	32	40	35	55	5	0.3	FDC-d12AA	HDP-12	S-3L
			2.4	3.1 ~ 5.0	KHS -02412	33 ~ 60									
			3.0	5.1 ~ 6.0	KHS -03012	33 ~ 60									
3050 25 # # # * * * *	KH-25E	25	0	3.6 ~ 16.0	KHS -00016	36 ~ 64(69)	36	44	35	60	6	0.4	FDC-d16AA	HDP-16	S-4L
			2.4	3.6 ~ 5.0	KHS -02416	39 ~ 67(72)									
			3.0	5.1 ~ 6.0	KHS -03016	39 ~ 67(72)									
3050 26 # # # * * * *	KH-26E	26	0	3.6 ~ 16.0	KHS -00016	36 ~ 64(69)	36	44	35	60	6	0.4	FDC-d16AA	HDP-16	S-4L
			2.4	3.6 ~ 5.0	KHS -02416	39 ~ 67(72)									
			3.0	5.1 ~ 6.0	KHS -03016	39 ~ 67(72)									
3050 28 # # # * * * *	KH-28E	28	0	6.1 ~ 9.0	KHS -04016	40 ~ 68(73)	36	47	35	65	6	0.5	FDC-d16AA	HDP-16	S-4L
			4.0	6.1 ~ 9.0	KHS -04016	40 ~ 68(73)									
			5.0	9.1 ~ 12.0	KHS -05016	41 ~ 69(74)									
3050 30 # # # * * * *	KH-30E	30	0	6.1 ~ 9.0	KHS -04016	40 ~ 68(73)	36	47	35	65	6	0.5	FDC-d16AA	HDP-16	S-4L
			4.0	6.1 ~ 9.0	KHS -04016	40 ~ 68(73)									
			5.0	9.1 ~ 12.0	KHS -05016	41 ~ 69(74)									
3050 32 # # # * * * *	KH-32E	32	0	3.6 ~ 22.0	KHS -00022	41 ~ 74	46	51	40	80	6	0.7	FDC-d22AA	HDP-22	S-5L
			2.4	3.6 ~ 5.0	KHS -02422	39 ~ 75									
			3.0	5.1 ~ 6.0	KHS -03022	39 ~ 75									
3050 35 # # # * * * *	KH-35E	35	0	6.1 ~ 9.0	KHS -04022	42 ~ 78	46	55	40	80	6	0.8	FDC-d22AA	HDP-22	S-5L
			4.0	6.1 ~ 9.0	KHS -04022	42 ~ 78									
			5.0	9.1 ~ 12.0	KHS -05022	48 ~ 84									
3050 36 # # # * * * *	KH-36E	36	0	6.1 ~ 9.0	KHS -04022	42 ~ 78	46	55	40	80	6	0.8	FDC-d22AA	HDP-22	S-5L
			4.0	6.1 ~ 9.0	KHS -04022	42 ~ 78									
			5.0	9.1 ~ 12.0	KHS -05022	48 ~ 84									
3050 48 # # # * * * *	KH-48E	48	0	20.1 ~ 32.0	KHS -00032	66 ~ 87	65	75	50	100	6	2.0	FDC-d32A	HDP-32	S-6
			8.0	20.1 ~ 32.0	KHS -08032	70 ~ 93									
			12.0	22.1 ~ 32.0	KHS -12032	78 ~ 109									

KHB-E

Cuerpo del Portaherramienta - Holder body

Portaherramienta
Holder

+

Conductor de
preajuste
Preset Driver

+

Tuerca ciega (sin
boquilla)
Nut (without collet)

Código Code	Modelo Model	B	L3	D _{0.07}	D1	D2	L1	L2	T	kg
3054 12 □□□ 000	/00006	0	20 ~ 45	12	23	24.3	34	35	-	0.1
	KHB -12E /02406	2.4	24 ~ 48							
	/03006	3	25 ~ 48							
3054 14 □□□ 000	/00007	0	20 ~ 45	14	23	26.3	34	35	-	0.1
	KHB -14E /02407	2.4	24 ~ 48							
	/03007	3	25 ~ 48							
	/04007	4	27 ~ 48							
3054 16 □□□ 000	/00009	0	29 ~ 46	16	26	32	35	40	24	0.2
	KHB -16E /02409	2.4	32 ~ 49							
	/03009	3	34 ~ 51							
	/04009	4	34 ~ 51							
3054 19 □□□ 000	KHB -19E /00009	0	29 ~ 51	19	26	35	35	45	24	0.2
	/02409	2.4	32 ~ 54							
3054 20 □□□ 000	KHB -20E /03009	3	34 ~ 56	20	26	35	35	45	24	0.2
		/04009	4							
3054 22 □□□ 000	/00012	0	35 ~ 62	22	32	38	35	55	30	0.3
	KHB -22E /02412	2.4	33 ~ 60							
	/03012	3	33 ~ 60							
3054 24 □□□ 000	/04012	4	37 ~ 64	24	32	40	35	55	30	0.3
	KHB -24E /05012	5	37 ~ 64							
3054 25 □□□ 000	KHB -25E /00016	0	36 ~ 64 (69)	25	36	44	35	60	33	0.4
	/02416	2.4	39 ~ 67 (72)							
3054 26 □□□ 000	KHB -26E /03016	3	39 ~ 67 (72)	26	36	44	35	60	33	0.4
3054 28 □□□ 000	KHB -28E /04016	4	40 ~ 68 (73)							
3054 30 □□□ 000	/05016	5	41 ~ 69 (74)	30	36	47	35	65	33	0.5
	KHB -30E /06016	6	44 ~ 72 (77)							
3054 32 □□□ 000	/00022	0	41 ~ 74	32	46	51	40	80	42	0.6
	KHB -32E /02422	2.4	39 ~ 75							
	/03022	3	39 ~ 75							
3054 35 □□□ 000	/04022	4	42 ~ 78	35	46	55	40	80	42	0.7
	KHB -35E /05022	5	48 ~ 84							
	/06022	6	54 ~ 90							
3054 36 □□□ 000	/08022	8	54 ~ 90	36	46	55	40	80	42	0.8
	KHB -36E									
3054 48 □□□ 000	/00032	0	66 ~ 87	48	65	75	50	100	-	1.8
	KHB -48E /08032	8	70 ~ 93							
	/12032	12	78 ~ 109							

- 1.La dimensión L3 entre parentésis representa la dimensión máx. del KH-28E y el KH-30E.
- 2.Favor de elegir el Conductor de preajuste de acuerdo con la medida de la espiga de la herramienta de corte (dirijase a la pág. 463)
- 3.La llave inglesa se vende por separado.
- 4.Dirijase a la pág. 464 para conocer las dimensiones del husillo.
 - 1.L3 dimension in bracket stands for max. dimension of KH-28E & KH-30E.
 - 2.Please select preset driver according to tang size of cutting tool. (Refer to P.463)
 - 3.Spanner is sold separately.
 - 4.Refer to P.464 for spindle dimension.



KH-E (Conjunto de boquilla - Collet set)

Ejemplo para Ordenar - Ordering Example

KH-20E / 04009 / 7.0

Conductor de preajuste
Preset driver

Diámetro Interno de Boquilla
Collet I.D.

KHB-E (Cuerpo de Portaherramienta - Holder body)

Ejemplo para Ordenar - Ordering Example

KHB-20E / 04009

Conductor de preajuste
Preset driver

KH-EC1

Quick Change Stub Holder (For High Coolant Pressure)

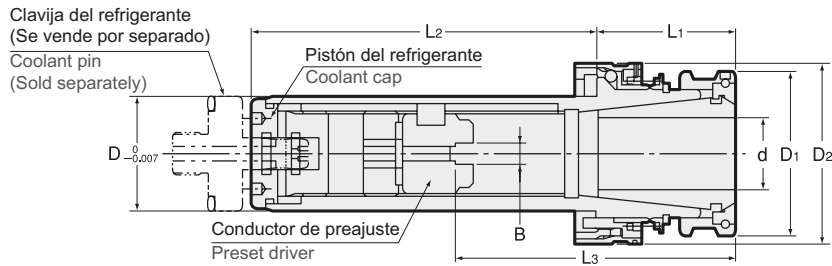

KHB-EC1

Cuerpo del Portaherramienta - Holder body



Código Code	Modelo Model	B	d D.I. Boquilla Collet I.D.	L3	D	D1	D2	L1	L2	kg	Refrigerante Máx. Max Coolant	Clavija del refrigerante Coolant pin	Boquilla Collet	
3055 14 ※※※ 000	KHB -14EC1	/00007	0	3.0 ~ 7.0	20 ~ 45	14	23	26.3	34	50	0.1	8MPa	KH-14EC-P	FDC-07-OH or C
		/02407	2.4	3.1 ~ 5.0	24 ~ 48									
		/03007	3.0	5.1 ~ 6.0	25 ~ 48									
		/04007	4.0	6.1 ~ 7.0	27 ~ 48									
3055 16 ※※※ 000	KHB -16EC1	/00009	0	3.0 ~ 9.0	29 ~ 47	16	26	32	35	55	0.2	8MPa	KH-16EC-P	FDC-09-OH or C
		/02409	2.4	3.1 ~ 5.0	32 ~ 50									
		/03009	3.0	5.1 ~ 6.0	34 ~ 52									
		/04009	4.0	6.1 ~ 9.0	34 ~ 52									
3055 19 ※※※ 000	KHB -19EC1	/00009	0	3.0 ~ 9.0	29 ~ 52	19	26	35	35	60	0.2	8MPa	KH-19EC-P	FDC-09-OH or C
		/02409	2.4	3.1 ~ 5.0	32 ~ 55									
		/03009	3.0	5.1 ~ 6.0	34 ~ 57									
3055 20 ※※※ 000	KHB -20EC1	/03009	3.0	5.1 ~ 6.0	34 ~ 57	20	26	35	35	60	0.2	8MPa	KH-20EC-P	FDC-09-OH or C
		/04009	4.0	6.1 ~ 9.0	34 ~ 57									
		/00012	0	3.0 ~ 12	35 ~ 62									
3055 22 ※※※ 000	KHB -22EC1	/02412	2.4	3.1 ~ 5.0	34 ~ 61	22	32	38	35	70	0.3	8MPa	KH-22EC-P	FDC-12-OH or C
		/03012	3.0	5.1 ~ 6.0	35 ~ 61									
		/04012	4.0	6.1 ~ 9.0	37 ~ 64									
3055 24 ※※※ 000	KHB -24EC1	/04012	4.0	6.1 ~ 9.0	37 ~ 64	24	32	40	35	70	0.4	8MPa	KH-24EC-P	FDC-12-OH or C
		/05012	5.0	9.1 ~ 12	37 ~ 64									
		/00016	0	6.0 ~ 16	36 ~ 64 (69)									
3055 25 ※※※ 000	KHB -25EC1	/00016	0	6.0 ~ 16	36 ~ 64 (69)	25	36	44	35	80	0.4	8MPa	KH-25EC-P	FDC-16-OH or C
		/03016	3.0	6.0	40 ~ 67 (72)									
		/04016	4.0	6.1 ~ 9.0	42 ~ 68 (73)									
3055 26 ※※※ 000	KHB -26EC1	/03016	3.0	6.0	40 ~ 67 (72)	26	36	44	35	80	0.4	8MPa	KH-26EC-P	FDC-16-OH or C
		/04016	4.0	6.1 ~ 9.0	42 ~ 68 (73)									
3055 28 ※※※ 000	KHB -28EC1	/04016	4.0	6.1 ~ 9.0	42 ~ 68 (73)	28	36	47	35	85	0.5	8MPa	KH-28EC-P	FDC-16-OH or C
		/05016	5.0	9.1 ~ 12	42 ~ 69 (74)									
3055 28 ※※※ 000	KHB -28EC1	/05016	5.0	9.1 ~ 12	42 ~ 69 (74)	30	36	47	35	85	0.6	8MPa	KH-30EC-P	FDC-16-OH or C
		/06016	6.0	12.1 ~ 16	44 ~ 72 (77)									
3055 30 ※※※ 000	KHB -30EC1	/06016	6.0	12.1 ~ 16	44 ~ 72 (77)	30	36	47	35	85	0.6	8MPa	KH-30EC-P	FDC-16-OH or C
		/00022	0	6.0 ~ 22	43 ~ 79									
3055 32 ※※※ 000	KHB -32EC1	/00022	0	6.0 ~ 22	43 ~ 79	32	46	51	40	100	0.7	8MPa	KH-32EC-P	FDC-22-OH or C
		/03022	3.0	6.0	47 ~ 82									
3055 32 ※※※ 000	KHB -32EC1	/03022	3.0	6.0	47 ~ 82	35	46	55	40	100	0.8	8MPa	KH-32EC-P	FDC-22-OH or C
		/04022	4.0	6.1 ~ 9.0	49 ~ 83									
		/05022	5.0	9.1 ~ 12	49 ~ 84									
3055 35 ※※※ 000	KHB -35EC1	/04022	4.0	6.1 ~ 9.0	49 ~ 83	35	46	55	40	100	0.8	8MPa	KH-35EC-P	FDC-22-OH or C
		/05022	5.0	9.1 ~ 12	49 ~ 84									
		/06022	6.0	12.1 ~ 16	54 ~ 90									
3055 35 ※※※ 000	KHB -35EC1	/06022	6.0	12.1 ~ 16	54 ~ 90	36	46	55	40	100	0.9	6MPa	KH-36EC-P	FDC-22-OH or C
		/08022	8.0	16.1 ~ 22	54 ~ 90									

Boquilla Collet Pág. 090 y 467	Llave Inglesa Spanner Pág. 469	Clavija del refrigerante Coolant Pin Pág. 456

- La dimensión L3 entre parentesis representa la dimensión máx. del KH-28EC1 y el KH-30EC1.
- La clavija del refrigerante, la boquilla y la llave inglesa se venden por separado.
- Después de quitar el pistón del refrigerante por la llave para la espiga ajustable (se vende por separado) la dimensión L3 puede ajustarse.
- Favor de elegir el conductor de preajuste según la medida de la espiga en la herramienta de corte (Dirijase a la pág. 463)
- Consulte la pág. 464 para conocer sobre la dimensión del husillo.
- L3 in bracket stands for KHB-28EC1 KHB-30EC1.
- Coolant pin, collet and spanner are sold separately.
- After removing coolant cap by adjustable pin wrench(sold separately), L3 dimension can be adjusted.
- Please select preset driver according to tang size of cutting tool. (Refer to P.463)
- Refer to P.464 for spindle dimension.

llave para la espiga ajustable (se vende por separado)
Adjustable pin wrench (sold separately)

Código Code	Modelo Model	Medida del portaherramienta Holder Size
0150 09300000	GWA1	KHB14 ~ KHB30
0150 09300040	GWA40	KHB32 ~ KHB36

Ejemplo para Ordenar - Ordering Example

KHB-20EC 1 / 03009

Tipo de presión alta del refrigerante
High coolant pressure type

Conductor de preajuste
Preset driver

KH-EC2

Quick Change Stub Holder (For Low Coolant Pressure)

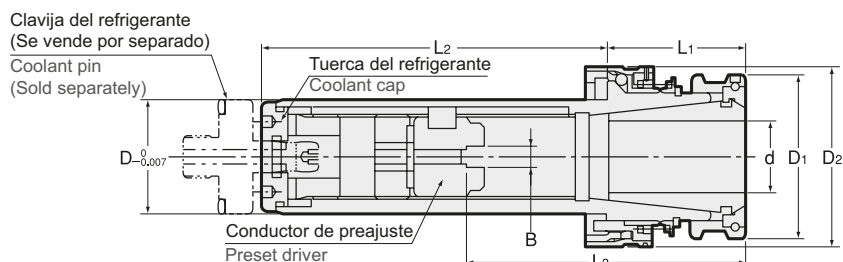

KHB-EC2 Cuerpo del Portaherramienta - Holder body

Portaherramienta Holder + Conductor de preajuste Preset Driver + Tuerca ciega Nut

Código Code	Modelo Model	B	d D. I, Boquilla Collet I.D.	L3	D	D1	D2	L1	L2	kg	Refrigerante Máx. Max. Coolant	Clavija del refrigerante Coolant pin	Boquilla Collet	
305614 *** 000	KHB -14EC2	/00007	0	3.0 ~ 7.0	20 ~ 45	14	23	26.3	34	50	0.1	5MPa	KH-14EC-P	FDC-07-OH or C
		/02407	2.4	3.1 ~ 5.0	24 ~ 48									
		/03007	3.0	5.1 ~ 6.0	25 ~ 48									
		/04007	4.0	6.1 ~ 7.0	27 ~ 48									
305616 *** 000	KHB -16EC2	/00009	0	3.0 ~ 9.0	29 ~ 47	16	26	32	35	55	0.2	5MPa	KH-16EC-P	FDC-09-OH or C
		/02409	2.4	3.1 ~ 5.0	32 ~ 50									
		/03009	3.0	5.1 ~ 6.0	34 ~ 52									
		/04009	4.0	6.1 ~ 9.0	34 ~ 52									
305619 *** 000	KHB -19EC2	/00009	0	3.0 ~ 9.0	29 ~ 52	19	26	35	35	60	0.2	5MPa	KH-19EC-P	FDC-09-OH or C
/02409	2.4	3.1 ~ 5.0	32 ~ 55											
305620 *** 000	KHB -20EC2	/03009	3.0	5.1 ~ 6.0	34 ~ 57	20	26	35	35	60	0.2	5MPa	KH-20EC-P	FDC-09-OH or C
		/04009	4.0	6.1 ~ 9.0	34 ~ 57									
305622 *** 000	KHB -22EC2	/00012	0	3.0 ~ 12	35 ~ 62	22	32	38	35	70	0.3	4MPa	KH-22EC-P	FDC-12-OH or C
		/02412	2.4	3.1 ~ 5.0	34 ~ 61									
		/03012	3.0	5.1 ~ 6.0	35 ~ 61									
305624 *** 000	KHB -24EC2	/04012	4.0	6.1 ~ 9.0	37 ~ 64	24	32	40	35	70	0.4	4MPa	KH-24EC-P	FDC-12-OH or C
		/05012	5.0	9.1 ~ 12	37 ~ 64									
305625 *** 000	KHB -25EC2	/00016	0	6.0 ~ 16	36 ~ 64 (69)	25	36	44	35	80	0.4	3MPa	KH-25EC-P	FDC-16-OH or C
305626 *** 000	KHB -26EC2	/03016	3.0	6.0	40 ~ 67 (72)	26	36	44	35	80	0.4	3MPa	KH-26EC-P	FDC-16-OH or C
305628 *** 000	KHB -28EC2	/04016	4.0	6.1 ~ 9.0	42 ~ 68 (73)	28	36	47	35	85	0.5	3MPa	KH-28EC-P	FDC-16-OH or C
305630 *** 000	KHB -30EC2	/05016	5.0	9.1 ~ 12	42 ~ 69 (74)	30	36	47	35	85	0.6	3MPa	KH-30EC-P	FDC-16-OH or C
305632 *** 000	KHB -32EC2	/00022	0	6.0 ~ 22	43 ~ 79	32	46	51	40	100	0.7	3MPa	KH-32EC-P	FDC-22-OH or C
		/03022	3.0	6.0	47 ~ 82									
305635 *** 000	KHB -35EC2	/04022	4.0	6.1 ~ 9.0	49 ~ 83	35	46	55	40	100	0.8	3MPa	KH-35EC-P	FDC-22-OH or C
		/05022	5.0	9.1 ~ 12	49 ~ 84									
305636 *** 000	KHB -36EC2	/06022	6.0	12.1 ~ 16	54 ~ 90	36	46	55	40	100	0.9	3MPa	KH-36EC-P	FDC-22-OH or C
		/08022	8.0	16.1 ~ 22	54 ~ 90									

Boquilla Collet
Pág. 090 y 467

Llave Inglesa Spanner
Pág. 469

Clavija del refrigerante Coolant Pin
Pág. 456

1. La dimensión L3 entre corchetes representa la dimensión máx. del KHB-28EC2 KHB-30EC2.
 2. La clavija del refrigerante, la boquilla y la llave inglesa se venden por separado.
 3. Favor de elegir el conductor de preajuste según la medida de la espiga en la herramienta de corte (Dirijase a la pág. 463)
Consulte la pág. 464 para conocer sobre la dimensión del husillo.
1. L3 in bracket stands for KHB-28EC2 KHB-30EC2.
 2. Coolant pin, collet and spanner are sold separately.
 3. Please select preset driver according to tang size of cuttingtool. (Refer to P.463)
Refer to P.464 for spindle dimension.

Llave para la espiga ajustable (se vende por separado) Adjustable pin wrench (sold separately)

Código Code	Modelo Model	Medida del portaherramienta Holder Size
0150 09300000	GWA1	KHB14 ~ KHB30
0150 09300040	GWA40	KHB32 ~ KHB36

Ejemplo para Ordenar - Ordering Example

KHB-20EC 2 / 03009
Tipo de baja presión de l refrigerante Low coolant pressure type / Conductor de preajuste Preset driver

Clavija del refrigerante
Coolant pin

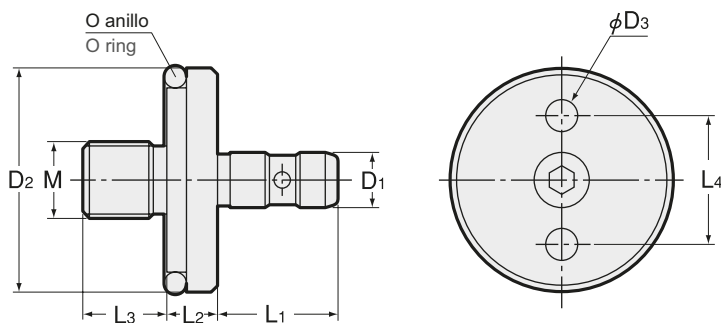

Código Code	Modelo Model	D1	D2	D3	L1	L2	L3	L4	kg	M	O anillo O ring
3055 00001402	KH14EC-P	5.7	13.9	3.5	15	8	13	9.6	0.01	M8 P=1	P-10A 1-B
3055 00001602	KH16EC-P	5.7	15.9	3.5	15	8	13	11	0.02	M8 P=1	P-12 1-B
3055 00001902	KH19EC-P	5.7	18.9	3.5	15	8	13	11	0.03	M8 P=1	P-15 1-B
3055 00002002	KH20EC-P	5.7	19.9	3.5	15	8	13	11	0.03	M8 P=1	P-16 1-B
3055 00002202	KH22EC-P	7.6	21.9	5.5	16.5	8	13	15.4	0.03	M10 P=1	P-18 1-B
3055 00002402	KH24EC-P	7.6	23.9	5.5	16.5	8	13	15.4	0.04	M10 P=1	P-20 1-B
3055 00002502	KH25EC-P	8.6	24.9	5.5	19	8	13	17	0.04	M12 P=1	P-21 1-B
3055 00002602	KH26EC-P	8.6	25.9	5.5	19	8	13	17	0.04	M12 P=1	P-22 1-B
3055 00002802	KH28EC-P	8.6	27.9	5.5	19	8	13	17	0.05	M12 P=1	P-22A 1-B
3055 00003002	KH30EC-P	8.6	29.9	5.5	19	8	13	17	0.05	M12 P=1	P-24 1-B
3055 00003202	KH32EC-P	8.6	31.9	5.5	19	8	13	20	0.06	M12 P=1	P-26 1-B
3055 00003502	KH35EC-P	8.6	34.9	5.5	19	8	13	20	0.06	M12 P=1	P-29 1-B
3055 00003602	KH36EC-P	8.6	35.9	5.5	19	8	13	20	0.06	M12 P=1	P-30 1-B

Llave para la clavija del refrigerante
Coolant pin wrench

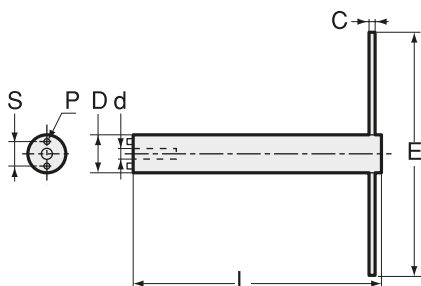

Modelo Model	Clavija del refrigerante Coolant pin	d	D	S	P	L	C	E	kg
HDMC -14G	KH14EC-P	6	13.5	9.6	3	120	6	120	
-16G	KH16EC-P KH19EC-P KH20EC-P	6	15.5	11	3	140	6	120	
-22G	KH22EC-P KH24EC-P	8	21.5	15.4	5	160	10	160	0.5
-25G	KH25EC-P KH26EC-P KH28EC-P KH30EC-P	9	24.5	17	5	180	10	160	0.7
-32G	KH32EC-P KH35EC-P KH36EC-P	9	31.5	20	5	200	12	200	1.4

La llave para la clavija del refrigerante es necesaria para reemplazar la clavija del refrigerante.

Coolant pin wrench is necessary to replace coolant pin.

Lineamientos de acabado en fresa con portaherramienta de zanco recto KH-E

Stub Holder KH-E Endmilling Guidelines

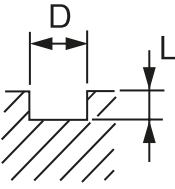
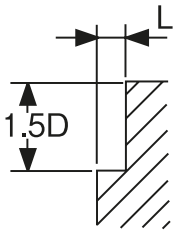
Forma Shape	Material Material	Diá. del cortador Cutter's dia	Rotación Rotation (min-1)	Suministro Feed (mm/min)	Longitud máx. de corte L Max. cutting length L			
					KH16E	KH22E	KH26E	KH35E
	Aluminio Aluminum (AC4C)	$\varnothing 6$	4,000	387	1D	1D	—	—
		$\varnothing 12$	3,150	400	—	1D	1D	—
		$\varnothing 16$	2,000	345	—	—	0.75D	0.75D
		$\varnothing 20$	1,000	315	—	—	—	0.5D
	Hierro fundido Cast Iron (FC25)	$\varnothing 6$	2,240	150	0.75D	1D	—	—
		$\varnothing 12$	1,000	190	—	0.75D	0.75D	—
		$\varnothing 16$	800	170	—	—	1D	0.75D
		$\varnothing 20$	630	160	—	—	—	0.5D
	Acero Steel (S45C)	$\varnothing 6$	1,000	48	1D	1D	—	—
		$\varnothing 12$	450	60	—	0.75D	1D	—
		$\varnothing 16$	355	60	—	—	0.5D	0.5D
		$\varnothing 20$	280	56	—	—	—	0.5D
	Aluminio Aluminum (AC4C)	$\varnothing 6$	9,000	1,000	0.3D	0.3D	—	—
		$\varnothing 12$	4,000	1,180	—	0.3D	0.3D	—
		$\varnothing 16$	3,150	1,060	—	—	0.3D	0.2D
		$\varnothing 20$	2,500	1,000	—	—	—	0.1D
	Hierro fundido Cast Iron (FC25)	$\varnothing 6$	2,650	355	0.1D	0.1D	—	—
		$\varnothing 12$	1,180	450	—	0.2D	0.2D	—
		$\varnothing 16$	950	400	—	—	0.2D	0.1D
		$\varnothing 20$	750	375	—	—	—	0.1D
	Acero Steel (S45C)	$\varnothing 6$	1,320	125	0.2D	0.2D	—	—
		$\varnothing 12$	600	160	—	0.2D	0.2D	—
		$\varnothing 16$	470	160	—	—	0.2D	0.1D
		$\varnothing 20$	375	150	—	—	—	0.1D

BT
CAT
AHO
HSK-A/E/F/C
HSK-T
C
UTS

Sistemas de
herramientado
de la serie
de máquinas
especializadas
Specialized
Machine

Equipo
Relacionado
Related
Equipment

Casquillos guía
y taladro de
biselado
Bush &
Chamfering
Drill

Stub Holder

Tapping Chuck

Tap Adapter

Adjustable
Adapter

Endmill Chuck

Straight Drill
Chuck

Floating Holder

KH-A

Quick Change Stub Holder

- Barrenado con portaherramientas de zanco recto para máquinas de propósitos especiales y máquinas transfer.
- Stub drilling for special purpose machines and transfer machines.

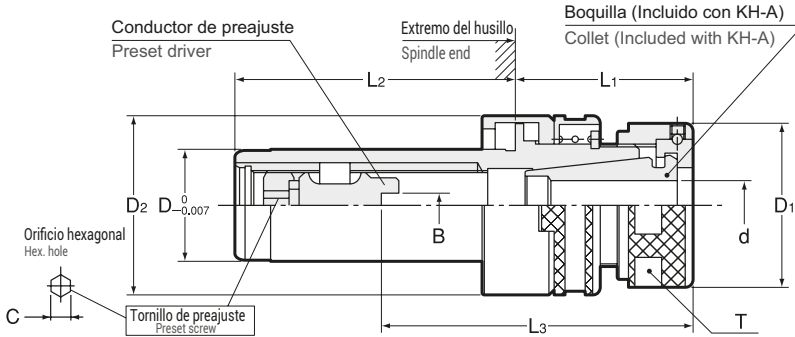

KH-A Conjunto de boquilla - Collet set



Stub Holder	Código Code	Modelo Model	D	B	d Rango de sujeción Chucking range d	Conductor de preajuste Preset Driver	L3	D1	D2	L1	L2	C	kg	Boquilla Collet	Tuerca ciega Nut	Llave Inglesa Spanner
Tapping Chuck	2340 121 □□※※※	KH-12AR	12	0	0.5 ~ 6.0	KHS -00006	23 ~ 45	19	20	34	35	3	0.1	FDC-d07A	KDP-1414	Llave con 17 mm de ancho (Flat 17mm width)
				2.4	3.1 ~ 5.0	KHS -02406	26 ~ 48									
				3.0	5.1 ~ 6.0	KHS -03006	26 ~ 48									
Tap Adapter	2340 141 □□※※※	KH-14AR	14	0	0.5 ~ 7.0	KHS -00007	23 ~ 45	19	24.3	34	35	4	0.1	FDC-d07A	KDP-1414	Llave con 17 mm de ancho (Flat 17mm width)
				2.4	3.1 ~ 5.0	KHS -02407	26 ~ 48									
				3.0	5.1 ~ 6.0	KHS -03007	26 ~ 48									
				4.0	6.1 ~ 7.0	KHS -04007	27 ~ 48									
Adjustable Adapter	2340 160 □□※※※	KH-16A	16	0	2.8 ~ 9.0	KHS -00009	28 ~ 45	26	29	35	40	4	0.2	EDC-d19	KDP-1916	S-1L
				2.4	3.1 ~ 5.0	KHS -02409	31 ~ 48									
				3.0	5.1 ~ 6.0	KHS -03009	33 ~ 50									
				4.0	6.1 ~ 9.0	KHS -04009	34 ~ 50									
Endmill Chuck	2340 190 □□※※※	KH-19A	19	0	2.8 ~ 9.0	KHS -00009	28 ~ 50	26	32	35	45	4	0.2	EDC-d19	KDP-1916	S-1L
				2.4	3.1 ~ 5.0	KHS -02409	31 ~ 53									
				3.0	5.1 ~ 6.0	KHS -03009	33 ~ 55									
Straight Drill Chuck	2340 200 □□※※※	KH-20A	20	0	2.8 ~ 9.0	KHS -00009	34 ~ 55	26	32	35	45	4	0.2	EDC-d19	KDP-1916	S-1L
				2.4	3.1 ~ 5.0	KHS -02409	31 ~ 53									
				3.0	5.1 ~ 6.0	KHS -03009	33 ~ 55									
Floating Holder	2340 220 □□※※※	KH-22A	22	0	2.8 ~ 12	KHS -00012	34 ~ 61	32	35	35	55	5	0.3	EDC-d24	KDP-2422	S-3L
				2.4	3.1 ~ 5.0	KHS -02412	32 ~ 59									
				3.0	5.1 ~ 6.0	KHS -03012	32 ~ 59									
	2340 240 □□※※※	KH-24A	24	4.0	6.1 ~ 9.0	KHS -04012	36 ~ 63	32	37	35	55	5	0.3	EDC-d24	KDP-2422	S-3L
				5.0	9.1 ~ 12	KHS -05012	39 ~ 63									
2340 250 □□※※※	KH-25A	25	0	4.0 ~ 16	KHS -00016	41 ~ 60 (65)	36	41	35	60	6	0.4	EDC-d28	KDP-2825	S-4L	
2340 260 □□※※※	KH-26A	26	2.4	4.0 ~ 5.0	KHS -02416	36 ~ 58 (63)	36	41	35	60	6	0.4	EDC-d28	KDP-2825	S-4L	
			3.0	5.1 ~ 6.0	KHS -03016	39 ~ 61 (66)										
2340 280 □□※※※	KH-28A	28	4.0	6.1 ~ 9.0	KHS -04016	42 ~ 64 (69)	36	44	35	65	6	0.5	EDC-d28	KDP-2825	S-4L	
			5.0	9.1 ~ 12	KHS -05016	47 ~ 69 (74)										
2340 300 □□※※※	KH-30A	30	6.0	12.1 ~ 16	KHS -06016	51 ~ 72 (77)	36	44	35	65	6	0.5	EDC-d28	KDP-2825	S-4L	
2340 320 □□※※※	KH-32A	32	0	4.0 ~ 22	KHS -00022	46 ~ 75	46	48	40	80	6	0.7	EDC-d36	KDP-3632	S-5L	
			2.4	4.0 ~ 5.0	KHS -02422	39 ~ 76										
			3.0	5.1 ~ 6.0	KHS -03022	39 ~ 76										
2340 350 □□※※※	KH-35A	35	4.0	6.1 ~ 9.0	KHS -04022	42 ~ 79	46	52	40	80	6	0.8	EDC-d36	KDP-3632	S-5L	
			5.0	9.1 ~ 12	KHS -05022	48 ~ 85										
			6.0	12.1 ~ 16	KHS -06022	54 ~ 91										
2340 360 □□※※※	KH-36A	36	8.0	16.1 ~ 22	KHS -08022	58 ~ 91	46	52	40	80	6	0.8	EDC-d36	KDP-3632	S-5L	
			12.0	22.1 ~ 32	KHS -12032	78 ~ 105										
2340 481 □□※※※	KH-48A	48	0	20.1 ~ 32	KHS -00032	66 ~ 83	65	70	45	100	6	1.8	FDC-d32B	HDP-32	S-6	
			8.0	20.1 ~ 22	KHS -08032	70 ~ 89										
			12.0	22.1 ~ 32	KHS -12032	78 ~ 105										

KHB-A Cuerpo del Portaherramienta - Holder body

Portaherramienta
Holder

+

Conductor de preajuste
Preset Driver

+

Tuerca ciega
Nut

Código Code	Modelo Model	B	L3	D	D1	D2	L1	L2	T	kg	
2340 121 □□□ 06	KHB -12AR	/00006	0	23 ~ 45	12	19	20	34	35	17	0.1
		/02406	2.4	26 ~ 48							
		/03006	3	26 ~ 48							
2340 141 □□□ 07	KHB -14AR	/00007	0	23 ~ 45	14	19	24.3	34	35	17	0.1
		/02407	2.4	26 ~ 48							
		/03007	3	26 ~ 48							
		/04007	4	27 ~ 48							
2340 160 □□□ 09	KHB -16A	/00009	0	28 ~ 45	16	26	29	35	40	24	0.15
		/02409	2.4	31 ~ 48							
		/03009	3	33 ~ 50							
		/04009	4	34 ~ 50							
2340 190 □□□ 09	KHB -19A	/00009	0	28 ~ 50	19	26	32	35	45	24	0.2
		/02409	2.4	31 ~ 53							
2340 200 □□□ 09	KHB -20A	/03009	3	33 ~ 55	20	26	32	35	45	24	0.2
		/04009	4	34 ~ 55							
2340 220 □□□ 12	KHB -22A	/00012	0	34 ~ 61	22	32	35	35	55	30	0.25
		/02412	2.4	32 ~ 59							
		/03012	3	32 ~ 59							
2340 240 □□□ 12	KHB -24A	/04012	4	36 ~ 63	24	32	37	35	55	30	0.3
		/05012	5	39 ~ 63							
2340 250 □□□ 16	KHB -25A	/00016	0	41 ~ 60(65)	25	36	41	35	60	33	0.35
		/02416	2.4	36 ~ 58(63)							
2340 260 □□□ 16	KHB -26A	/03016	3	39 ~ 61(66)	26	36	41	35	60	33	0.35
2340 280 □□□ 16	KHB -28A	/04016	4	42 ~ 64(69)	28	36	44	35	65	33	0.4
		/05016	5	47 ~ 69(74)							
2340 300 □□□ 16	KHB -30A	/06016	6	51 ~ 72(77)	30	36	44	35	65	33	0.45
2340 320 □□□ 22	KHB -32A	/00022	0	46 ~ 75	32	46	48	40	80	42	0.6
		/02422	2.4	39 ~ 76							
		/03022	3	39 ~ 76							
2340 350 □□□ 22	KHB -35A	/04022	4	42 ~ 79	35	46	52	40	80	42	0.7
		/05022	5	48 ~ 85							
2340 360 □□□ 22	KHB -36A	/06022	6	54 ~ 91	36	46	52	40	80	42	0.8
		/08022	8	58 ~ 91							
2340 480 □□□ 32	KHB -48A	/00032	0	66 ~ 83	48	65	70	45	100	-	1.6
		/08032	8	70 ~ 89							
		/12032	12	78 ~ 105							

- 1.La dimensión L3 entre paréntesis representa la dimensión máx. del KH-28E y el KH-30E.
- 2.Favor de elegir el Conductor de preajuste de acuerdo con la medida de la espiga de la herramienta de corte (diríjase a la pág. 463)
- 3.La llave inglesa se vende por separado.
- 4.Diríjase a la pág. 464 para conocer la dimensión del husillo.

- 1.L3 dimension in bracket stands for max. dimension of KH-28E & KH-30E.
- 2.Please select preset driver according to tang size of cutting tool. (Refer to P.463)
- 3.Spanner is sold separately.
- 4.Refer to P.464 for spindle dimension.

Boquilla
Collet

Pág. 467



Llave Inglesa
Spanner

Pág. 469



Conductos de preajuste
Preset Driver

Pág. 463

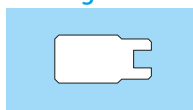

KH-A (Conjunto de boquilla - Collet set)

Ejemplo para Ordenar - Ordering Example

KH-20A / 04009 / 7.0
Conductor de preajuste / Diámetro Interno de Boquilla
Preset driver / Collet I.D.

KHB-A (Cuerpo de Portaherramienta - Holder body)

Ejemplo para Ordenar - Ordering Example

KHB-20A / 04009
Conductor de preajuste
Preset driver

KH-A-NL

Portaherramienta de zanco recto y cambio rápido para machuelo
Quick Change Stub Tapper

Aplicaciones Applications

- Diseñado para usarse en husillos KH-A
- Suministro del husillo: compatible con todos los tipos de suministro de las máquinas. Para suministros del husillo que no sean por suministro de inclinación (que no tengan función de "pitch fit") usar el machuelo KH-A-NL sin sobrecargar la función de tensión, es decir, que el ajuste de longitud de proyección no supere la mitad de su capacidad.
- Designed for use on KH-A spindle.
- Spindle Feed: All kinds of feed styles. For spindle feed other than pitch feed, use KH-A-NL in a condition where the tension feature always works a little. In this case, the length adjustment should be retained less than half.

Característica Feature

- Longitud de proyección corta. Machuelado estable.
- La longitud de proyección es ajustable.
- Compensación de la longitud.
- Cambio rápido
- Small projection length. Stable tapping.
- Projection length is adjustable
- Length compensation.
- Quick change

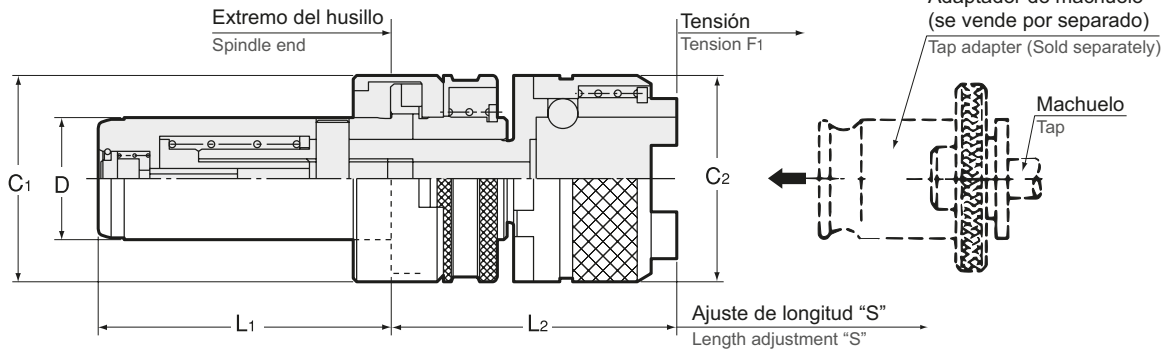

! Para conocer las medidas de machuelo adecuadas, favor de dirigirse a la tabla en la pág. 484-486.
For capable tap sizes, please refer to P. 484-486 chart.

Código Code	Modelo Model	Medida de machuelo Tap Size	Medida de adaptador Adapter size	D	C1	C2	L1	L2	S Max	F1	kg
2940 00014006	KH 14A-NL006	M3 ~ M8 (M10) U1/4 ~ U5/16 (U3/8)	0	14	24.3	23	35	50+S	6	6 - S	0.13
2940 00016008	KH 16A-NL008		0	16	29	23	40	47+S	8	8 - S	0.2
2940 00019110	KH 19A-NL110		1	19	32	32	45	45+S	10	10 - S	0.25
2940 00020110	KH 20A-NL110		1	20	32	32	45	45+S	10	10 - S	0.25
2940 00022110	KH 22A-NL110		1	22	35	32	55	45+S	10	10 - S	0.33
2940 00024110	KH 24A-NL110		1	24	37	32	55	45+S	10	10 - S	0.37
2940 00025115	KH 25A-NL115		1	25	41	32	60	45+S	15	15 - S	0.45
2940 00026115	KH 26A-NL115		1	26	41	32	60	45+S	15	15 - S	0.45
2940 00028215	KH 28A-NL215		2	28	44	50	65	60+S	15	15 - S	0.75
2940 00030215	KH 30A-NL215		2	30	44	50	65	60+S	15	15 - S	0.8
2940 00032220	KH 32A-NL220		2	32	48	50	80	60+S	20	20 - S	
2940 00035220	KH 35A-NL220		2	35	52	50	80	60+S	20	20 - S	
2940 00036220	KH 36A-NL220		2	36	52	50	80	60+S	20	20 - S	
2940 00048320	KH 48A-NL320		3	48	70	72	100	90+S	20	20 - S	

1. Las medidas del machuelo mostradas entre paréntesis son sólo para machueados ligeros.
2. El adaptador de machuelo se vende por separado.
3. Le sugerimos tener una brecha con libertad de 1mm. con la herramienta ya que la dimensión de L2 es dispersa.
4. Consulte la pág. 464 para conocer la dimensión del husillo.

1. Tap sizes in brackets are for light tapping only.
2. Tap adapter is sold separately.
3. We recommend you to have 1mm leeway in your tool layout, as L2 dimension is dispersed.
4. Refer to P.464 for spindle dimension.

Adaptador de machuelo
Tap Adapter
Pág. 480

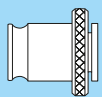

Ejemplo para Ordenar - Ordering Example

KH-14A - NL 0 06

Medida de adaptador

Compensación de la longitud (S Máx)

Adapter size

Length compensation (S Max)



Quick Change Stub Holder

Aplicaciones Applications

● Para aleación de aluminio y acero fundido (para acero fundido solo es posible barrenado). En caso de usar una medida de broca de $\phi 12$ o superior o trabajar en acero fundido con refrentado favor de contactar a NT Tool.

● Máquina de propósitos generales.
Para máquina de transferencia, etcétera.

● For aluminum alloy and cast iron. (For cast iron, drilling only) In case of using $\phi 12$ and above drill size or spot-facing cast iron, please contact NT Tool.

● Special purpose machine
For transfer machine, etc.

Característica Feature

● Para el procesamiento de la inclinación de husillo angosto

● For narrow spindle pitch processing.

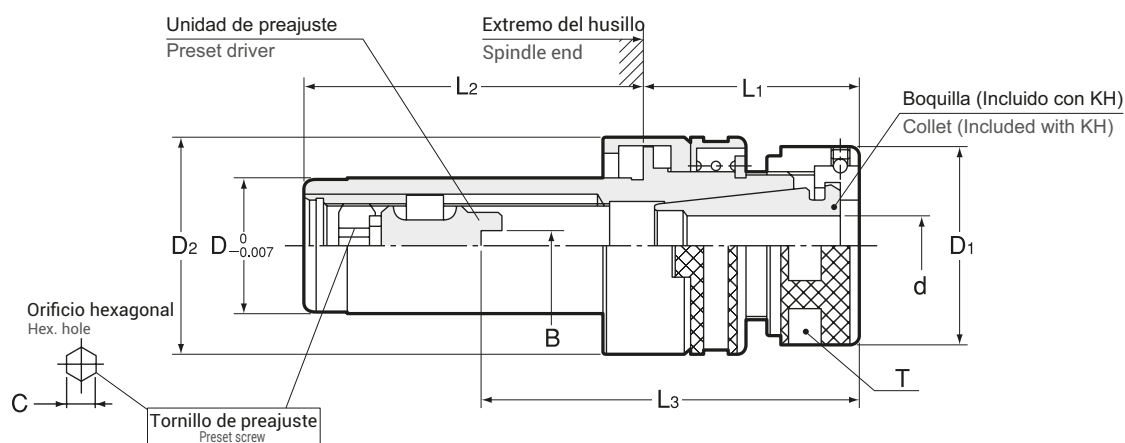

※ Incompatible con el KH-E y el KH-A

※ Incompatible with KH-E and KH-A.



Set de boquilla - Collet set



Código Code	Modelo Model	D	B	d Rango de sujeción Chucking range d	Unidad de preajuste Preset Driver	L3	D1	D2	L1	L2	T	C	kg	Boquilla Collet	Tuerca ciega Nut	Llave Inglesa Spanner
2300141 □□※※※	KH-14R	14	0	0.5 ~ 7.0	KHS -00007	23 ~ 45										
		2.4	3.1 ~ 5.0	KHS -02407	26 ~ 48	19	22	34	35	17	4	0.1	FDC-d07A	KDP-1414	Llave con 17 mm de ancho (Flat 17mm width)	
		3.0	5.1 ~ 6.0	KHS -03007	26 ~ 48											
		4.0	6.1 ~ 7.0	KHS -04007	27 ~ 48											
2300160 □□※※※	KH-16	16	0	2.8 ~ 9.0	KHS -00009	28 ~ 45										
		2.4	3.1 ~ 5.0	KHS -02409	31 ~ 48	26	26	35	40	24	4	0.15	EDC-d19	KDP-1916	S-1L	
		3.0	5.1 ~ 6.0	KHS -03009	33 ~ 50											
		4.0	6.1 ~ 9.0	KHS -04009	34 ~ 50											
2300190 □□※※※	KH-19	19	0	2.8 ~ 9.0	KHS -00009	28 ~ 50										
		2.4	3.1 ~ 5.0	KHS -02409	31 ~ 53	26	30	35	45	24	4		EDC-d19	KDP-1916	S-1L	
2300200 □□※※※	KH-20	20	0	5.1 ~ 6.0	KHS -03009	33 ~ 55										
		3.0	5.1 ~ 6.0	KHS -03009	33 ~ 55	26	30	35	45	24	4		EDC-d19	KDP-1916	S-1L	
2300220 □□※※※	KH-22	22	0	2.8 ~ 12	KHS -00012	34 ~ 61										
		2.4	3.1 ~ 5.0	KHS -02412	32 ~ 59	32	33	35	55	30	5	0.27	EDC-d24	KDP-2422	S-3L	
		3.0	5.1 ~ 6.0	KHS -03012	32 ~ 59											
		4.0	6.1 ~ 9.0	KHS -04012	36 ~ 63	32	35	35	55	30	5		EDC-d24	KDP-2422	S-3L	
2300240 □□※※※	KH-24	24	0	9.1 ~ 12	KHS -05012	39 ~ 63										
		5.0	9.1 ~ 12	KHS -05012	39 ~ 63											





Código Code	Modelo Model	B	L3	D	D1	D2	L1	L2	T	C	
2340 141 □□□ 07	KHB -14R	/00007	0	23 ~ 45	14	19	22	34	35	17	4
		/02407	2.4	26 ~ 48							
		/03007	3.0	26 ~ 48							
		/04007	4.0	27 ~ 48							
2340 160 □□□ 09	KHB -16	/00009	0	28 ~ 45	16	26	26	35	40	24	4
		/02409	2.4	31 ~ 48							
		/03009	3.0	33 ~ 50							
		/04009	4.0	34 ~ 50							
2340 190 □□□ 09	KHB -19	/00009	0	28 ~ 50	19	26	30	35	45	24	4
		/02409	2.4	31 ~ 53							
2340 200 □□□ 09	KHB -20	/03009	3.0	33 ~ 55	20	26	30	35	45	24	4
		/04009	4.0	34 ~ 55							
		/00012	0	34 ~ 61							
2340 220 □□□ 12	KHB -22	/02412	2.4	32 ~ 59	22	32	33	35	55	30	5
		/03012	3.0	32 ~ 59							
		/04012	4.0	36 ~ 63							
2340 240 □□□ 12	KHB -24	/05012	5.0	39 ~ 63	24	32	35	35	55	30	5

BT
 CAT
 AHO
 HSK-A/E/F/C
 HSK-T
 C
 UTS
 Sistemas de
 herramienta
 de la serie
 de máquinas
 especiales
 Specialized
 Machine
 Equipo
 Relacionado
 Related
 Equipment
 Casquillos guía
 y taladro de
 biselado
 Bush &
 Chamfering
 Drill

Stub Holder
 Tapping Chuck
 Tap Adapter
 Adjustable
 Adapter
 Endmill Chuck
 Straight Drill
 Chuck
 Floating Holder

Boquilla Collet Pág. 467 	Llave Inglesa Spanner Pág. 469 	Unidad de preajuste Preset Driver Pág. 463 
--	--	---

KH (Set con boquilla - Collet set)

Ejemplo para Ordenar - Ordering Example

KH-20 / 04009 / 7.0
 Unidad de preajuste Diámetro Interno de Boquilla
 Preset driver Collet I.D.

KHB (Cuerpo de Portaherramienta - Holder body)

Ejemplo para Ordenar - Ordering Example

KHB-20 / 04009
 Unidad de preajuste
 Preset driver

Accesorios
Accessories

Unidad de preajuste - Preset driver (For KH-E, KH-A, KH)

Tipo 1 sin espiga
Type1 without tang

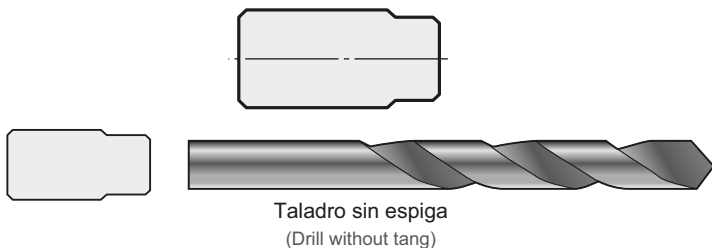

Tipo 2 con espiga
Type 2 with tang

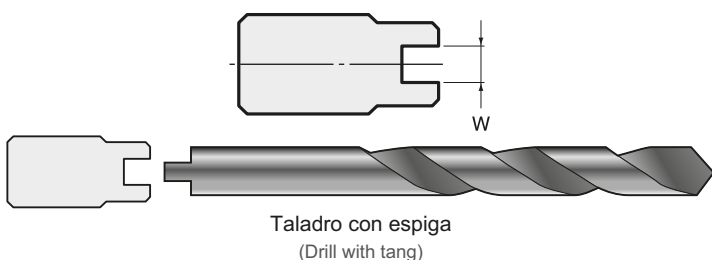

Modelo Model	Modelo de portaherramienta Holder model	Tipo Type	W ^{+0.4} / _{+0.3}
KHS	KH-12E KH-12AR	1	—
		2	2.4
		2	3
KHS	KH-14E KH-14AR KH-14R	1	—
		2	2.4
		2	3
		2	4
KHS	KH-16E,16A,16 KH-19E,19A,19 KH-20E,20A,20	1	—
		2	2.4
		2	3
		2	4
KHS	KH-22E,22A,22 KH-24E,24A,24	1	—
		2	2.4
		2	3
		2	4
		2	5
KHS	KH-25E,25A KH-26E,26A KH-28E,28A KH-30E,30A	1	—
		2	2.4
		2	3
		2	4
		2	5
		2	6
KHS	KH-32E,32A KH-35E,35A KH-36E,36A	1	—
		2	2.4
		2	3
		2	4
		2	5
		2	6
		2	8
KHS	KH-48E KH-48A	1	—
		2	8
		2	12

Unidad de preajuste - Preset driver (For KH-EC)

Tipo 1 sin espiga
Type1 without tang

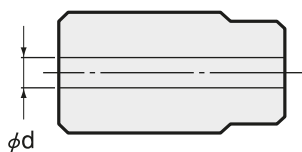

Tipo 2 con espiga
Type2 with tang

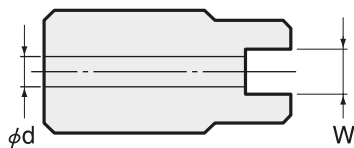

Modelo Model	Modelo de portaherramienta Holder model	Tipo Type	W ^{+0.4} / _{+0.3}	d	
KHS	KHB-14EC1,2	0007-OH	2	2.4	2.5
		02407-OH	2	2.4	2.5
		03007-OH	2	3	2.5
		04007-OH	2	4	2.5
KHS	KHB-16EC1,2 KHB-19EC1,2 KHB-20EC1,2	0009-OH	2	2.4	2.5
		02409-OH	2	2.4	2.5
		03009-OH	2	3	3
		04009-OH	2	4	3
KHS	KHB-22EC1,2 KHB-24EC1,2	0012-OH	1	—	2.5
		02412-OH	2	2.4	2.5
		03012-OH	2	3	3
		04012-OH	2	4	4
		05012-OH	2	5	5
KHS	KHB-25EC1,2 KHB-26EC1,2 KHB-28EC1,2 KHB-30EC1,2	0016-OH	1	—	2.5
		03016-OH	2	3	3
		04016-OH	2	4	4
		05016-OH	2	5	5
		06016-OH	2	6	6
		08016-OH	2	8	8
KHS	KHB-32EC1,2 KHB-35EC1,2 KHB-36EC1,2	0022-OH	1	—	2.5
		03022-OH	2	3	3
		04022-OH	2	4	4
		05022-OH	2	5	5
		06022-OH	2	6	6
08022-OH	2	8	8		

Dimensiones del husillo para los portaherramienta de zanco recto de cambio rápido

Spindle Dimensions For Quick Change Stub Holder

Dimensión para el husillo KH-E Dimension for KH-E spindle

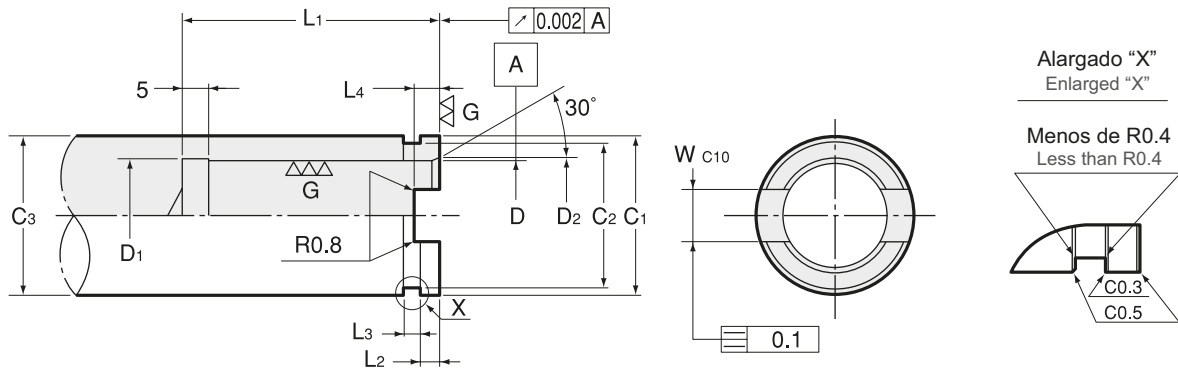

Alargado "X"
Enlarged "X"

Menos de R0.4
Less than R0.4

Todas las esquinas no especificadas se deben biselar a C0.5

- Material del extremo final del husillo: SCM415
- Tratamiento de calor: HV613 ~ 697
- Profundidad carburizada: 0.4 ~ 0.6

All corners not specified should be chamfered to C0.5.

- Material of spindle end : SCM415
- Heat treatment : HV613 ~ 697
- Carburized depth : 0.4 ~ 0.6

Medida Size	D +0.010 +0.005	D1	D2	C1 0 -0.1	C2 0 -0.1	C3	L1	L2 +0.1 0	L3	L4	W C10
12E	12	12.4	13.5	18	16.5	18 ó más (or more)	38	2.5	2.5	3.5	6
14E	14	14.4	15.5	22	20	20 ó más (or more)	38	2.5	2.5	3.5	8
16E	16	16.4	17.5	26.4	24	25 ó más (or more)	43	3.5	3.0	4.5	8
19E	19	19.4	20.5	29.4	27	28 ó más (or more)	48	3.5	3.0	4.5	9
20E	20	20.4	21.5	29.4	27	28 ó más (or more)	48	3.5	3.0	4.5	9
22E	22	22.4	23.5	32.4	30	32 ó más (or more)	58	3.5	3.0	4.5	10
24E	24	24.4	25.5	34.4	32	32 ó más (or more)	58	3.5	3.0	4.5	10
25E	25	25.4	26.5	37.4	35	35 ó más (or more)	63	3.5	3.0	4.5	10
26E	26	26.4	27.5	37.4	35	35 ó más (or more)	63	3.5	3.0	4.5	10
28E	28	28.4	29.5	40.4	38	40 ó más (or more)	68	3.5	3.0	4.5	10
30E	30	30.4	31.5	40.4	38	40 ó más (or more)	68	3.5	3.0	4.5	10
32E	32	32.4	33.5	43.8	41	45 ó más (or more)	83	3.5	3.0	4.5	10
35E	35	35.4	36.5	47.8	45	45 ó más (or more)	83	3.5	3.0	4.5	10
36E	36	36.4	37.5	47.8	45	45 ó más (or more)	83	3.5	3.0	4.5	10
48E	48	48.4	49.5	65.4	62	65 ó más (or more)	103	4.5	4.0	5.5	11

Dimensión para el husillo KH-EC Dimension for KH-EC spindle

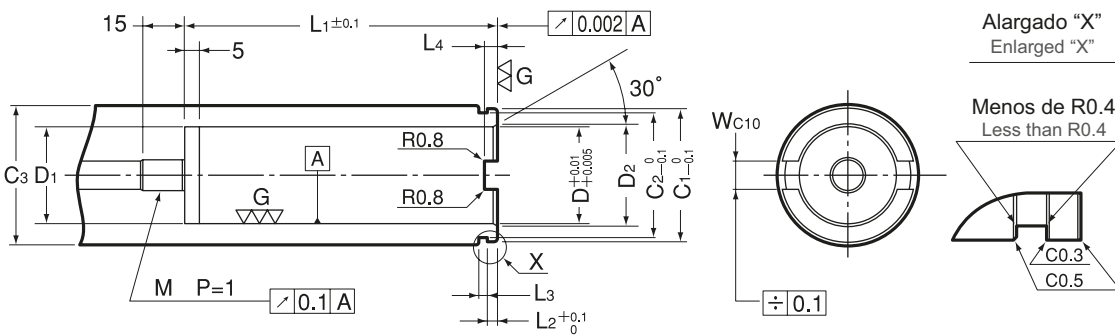

Alargado "X"
Enlarged "X"

Menos de R0.4
Less than R0.4

Todas las esquinas no especificadas se deben biselar a C0.5

- Material del extremo final del husillo: SCM415
- Tratamiento de calor: HV613 ~ 697
- Profundidad carburizada: 0.4 ~ 0.6

All corners not specified should be chamfered to C0.5.

- Material of spindle end : SCM415
- Heat treatment : HV613 ~ 697
- Carburized depth : 0.4 ~ 0.6

Medida Size	D +0.010 +0.005	D1	D2	C1 0 -0.1	C2 0 -0.1	C3	L1	L2 +0.1 0	L3	W C10	L4	M
14EC	14	14.4	15.5	22	20	20 ó más (or more)	60	2.5	2.5	8	3.5	M8 P=1
16EC	16	16.4	17.5	26.4	24	25 or more	65	3.5	3.0	8	4.5	M8 P=1
19EC	19	19.4	20.5	29.4	27	28 or more	70	3.5	3.0	9	4.5	M8 P=1
20EC	20	20.4	21.5	29.4	27	28 or more	70	3.5	3.0	9	4.5	M8 P=1
22EC	22	22.4	23.5	32.4	30	32 or more	80	3.5	3.0	10	4.5	M10 P=1
24EC	24	24.4	25.5	34.4	32	32 or more	80	3.5	3.0	10	4.5	M10 P=1
25EC	25	25.4	26.5	37.4	35	35 or more	91	3.5	3.0	10	4.5	M12 P=1
26EC	26	26.4	27.5	37.4	35	35 or more	91	3.5	3.0	10	4.5	M12 P=1
28EC	28	28.4	29.5	40.4	38	40 or more	96	3.5	3.0	10	4.5	M12 P=1
30EC	30	30.4	31.5	40.4	38	40 or more	96	3.5	3.0	10	4.5	M12 P=1
32EC	32	32.4	33.5	43.8	41	45 or more	111	3.5	3.0	10	4.5	M12 P=1
35EC	35	35.4	36.5	47.8	45	45 or more	111	3.5	3.0	10	4.5	M12 P=1
36EC	36	36.4	37.5	47.8	45	45 or more	111	3.5	3.0	10	4.5	M12 P=1

Dimensión para el husillo KH-A
Dimension for KH-A spindle

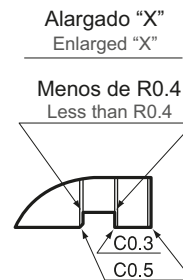
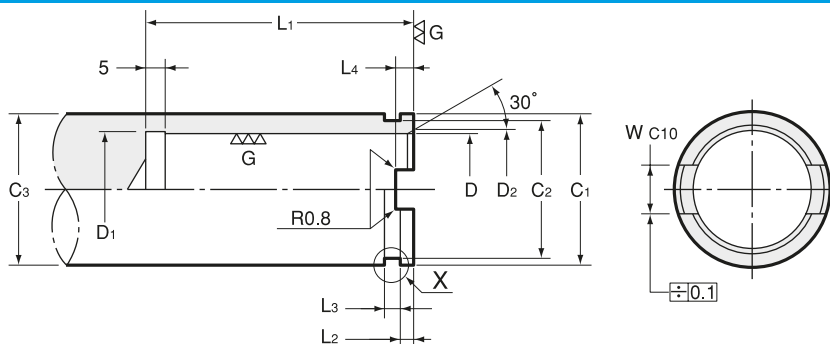

Medida Size	D +0.015 +0.005	D1	D2	C1 0 -0.1	C2 0 -0.1	C3	L1	L2 +0.1 0	L3	W C10	L4
12AR	12	12.4	13.5	18	16.5	18 ó más (or more)	38	2.5	2.5	6	3.5
14AR	14	14.4	15.5	22	20	20 ó más (or more)	38	2.5	2.5	8	3.5
16A	16	16.4	17.5	26.4	24	25 ó más (or more)	43	3.5	3.0	8	4.5
19A	19	19.4	20.5	29.4	27	28 ó más (or more)	48	3.5	3.0	9	4.5
20A	20	20.4	21.5	29.4	27	28 ó más (or more)	48	3.5	3.0	9	4.5
22A	22	22.4	23.5	32.4	30	32 ó más (or more)	58	3.5	3.0	10	4.5
24A	24	24.4	25.5	34.4	32	32 ó más (or more)	58	3.5	3.0	10	4.5
25A	25	25.4	26.5	37.4	35	35 ó más (or more)	63	3.5	3.0	10	4.5
26A	26	26.4	27.5	37.4	35	35 ó más (or more)	63	3.5	3.0	10	4.5
28A	28	28.4	29.5	40.4	38	40 ó más (or more)	68	3.5	3.0	10	4.5
30A	30	30.4	31.5	40.4	38	40 ó más (or more)	68	3.5	3.0	10	4.5
32A	32	32.4	33.5	43.8	41	45 ó más (or more)	83	3.5	3.0	10	4.5
35A	35	35.4	36.5	47.8	45	45 ó más (or more)	83	3.5	3.0	10	4.5
36A	36	36.4	37.5	47.8	45	45 ó más (or more)	83	3.5	3.0	10	4.5
48A	48	48.4	49.5	65.4	62	65 ó más (or more)	10	4.5	4.0	11	5.5

1. Dimensión del husillo únicamente para el KH-A, no para el KH.
 2. Todas las esquinas no especificadas se deben biselar a C0.5
- Material del extremo final del husillo: SCM415
 - Tratamiento de calor: HV613 ~ 697
 - Profundidad carburizada: 0.4 ~ 0.6

1. Spindle dimension for KH-A only, not for KH.
 2. All corners not specified should be chamfered to C0.5.
- Material of spindle end : SCM415
 - Heat treatment : HV613 ~ 697
 - Carburized depth : 0.4 ~ 0.6

Dimensión para el huso KH
Dimension for KH-spindle

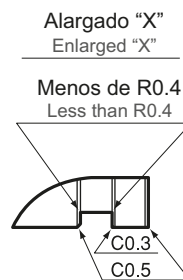
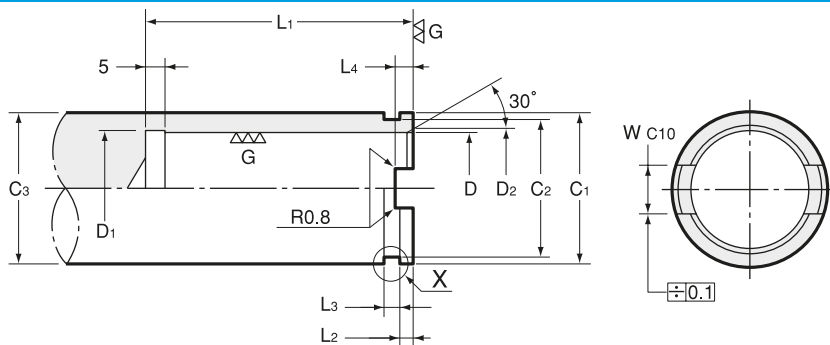

Medida Size	D +0.015 +0.005	D1	D2	C1 0 -0.1	C2 0 -0.1	C3	L1	L2 +0.1 0	L3	W C10	L4
14	14	14.4	15.5	19.8	18	20 ó más (or more)	38	2.5	2.5	8	3.5
16	16	16.4	17.5	23.8	21.4	25 or more	43	3.5	3.0	8	4.5
19	19	19.4	20.5	27.8	25.4	28 or more	48	3.5	3.0	9	4.5
20	20	20.4	21.5	27.8	25.4	28 or more	48	3.5	3.0	9	4.5
22	22	22.4	23.5	30.3	27.9	32 or more	58	3.5	3.0	10	4.5
24	24	24.4	25.5	32.3	29.9	35 or more	58	3.5	3.0	10	4.5

1. Dimensión del husillo únicamente para el KH, no para el KH-A.
 2. Todas las esquinas no especificadas se deben biselar a C0.5
- Material del extremo del husillo: SCM415
 - Tratamiento de calor: HV613 ~ 697
 - Profundidad carburizada: 0.4 ~ 0.6

1. Spindle dimension for KH only, not for KH-A.
 2. All corners not specified should be chamfered to C0.5.
- Material of spindle end : SCM415
 - Heat treatment : HV613 ~ 697
 - Carburized depth : 0.4 ~ 0.6

Dimensión del espaciador

Spacer Dimension

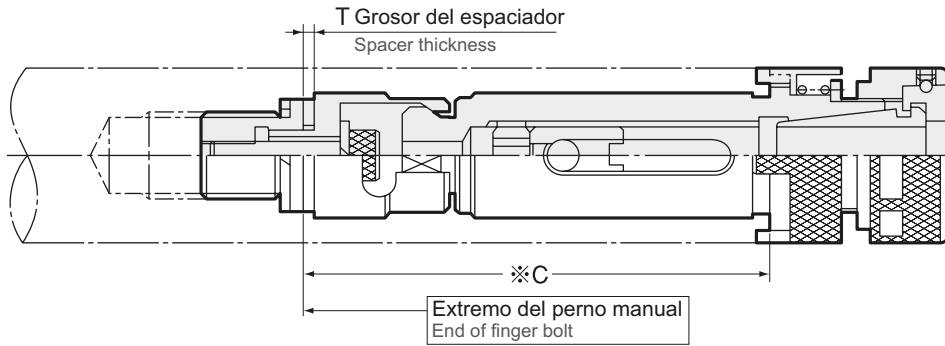

Modelo Model	Figura medida ※ C : Measured figure	T ±0.01
KD-14R2	58.26 ~ 58.41	0.83
	58.42 ~ 58.57	0.98
	58.58 ~ 58.73	1.13
KD-16	68.26 ~ 68.41	2.24
	68.42 ~ 68.57	2.39
	68.58 ~ 68.73	2.54
KD-19	78.26 ~ 78.41	2.24
	78.42 ~ 78.57	2.39
KD-20	78.58 ~ 78.73	2.54
	83.96 ~ 84.11	1.94
KD-22	84.12 ~ 84.27	2.09
	84.28 ~ 84.43	2.24
KD-24	99.26 ~ 99.41	3.24
	99.42 ~ 99.57	3.39
KD-25	99.58 ~ 99.73	3.54
	117.26 ~ 117.41	2.74
KD-26	117.42 ~ 117.57	2.89
	117.58 ~ 117.73	3.04
KD-28	139.26 ~ 139.41	2.74
	139.42 ~ 139.57	2.89
	139.58 ~ 139.73	3.04
KD-30	139.26 ~ 139.41	2.74
	139.42 ~ 139.57	2.89
	139.58 ~ 139.73	3.04

EDC、FDC-07A、FDC-32B

Boquilla - Collet

Diá. de zanco de cortador Cutter's shank dia.	Modelo - Model				Diá. de zanco de cortador Cutter's shank dia.	Model - Model FDC-07A
	EDC-19	EDC-24	EDC-28	EDC-36		
φ 2.8 ~ 3.0	EDC-0319	EDC-0324	—	—	φ 0.5 ~ 1.0	FDC-01007A
φ 3.0 ~ 3.3	EDC-03319	EDC-03324	—	—	φ 1.0 ~ 1.5	FDC-01507A
φ 3.3 ~ 3.6	EDC-03619	EDC-03624	—	—	φ 1.5 ~ 2.0	FDC-02007A
φ 3.6 ~ 3.9	EDC-03919	EDC-03924	—	—	φ 2.0 ~ 2.5	FDC-02507A
φ 3.9 ~ 4.2	EDC-04219	EDC-04224	EDC-04228	EDC-04236	φ 2.5 ~ 3.0	FDC-03007A
φ 4.2 ~ 4.5	EDC-04519	EDC-04524	EDC-04528	EDC-04536	φ 3.0 ~ 3.5	FDC-03507A
φ 4.5 ~ 5.0	EDC-0519	EDC-0524	EDC-0528	EDC-0536	φ 3.5 ~ 4.0	FDC-04007A
φ 5.0 ~ 5.5	EDC-05519	EDC-05524	EDC-05528	EDC-05536	φ 4.0 ~ 4.5	FDC-04507A
φ 5.5 ~ 6.0	EDC-0619	EDC-0624	EDC-0628	EDC-0636	φ 4.5 ~ 5.0	FDC-05007A
φ 6.0 ~ 6.5	EDC-06519	EDC-06524	EDC-06528	EDC-06536	φ 5.0 ~ 5.5	FDC-05507A
φ 6.5 ~ 7.0	EDC-0719	EDC-0724	EDC-0728	EDC-0736	φ 5.5 ~ 6.0	FDC-06007A
φ 7.0 ~ 7.5	EDC-07519	EDC-07524	EDC-07528	EDC-07536	φ 6.0 ~ 6.5	FDC-06507A
φ 7.5 ~ 8.0	EDC-0819	EDC-0824	EDC-0828	EDC-0836	φ 6.5 ~ 7.0	FDC-07007A
φ 8.0 ~ 8.5	EDC-08519	EDC-08524	EDC-08528	EDC-08536		
φ 8.5 ~ 9.0	EDC-0919	EDC-0924	EDC-0928	EDC-0936		
φ 9.0 ~ 9.5	—	EDC-09524	EDC-09528	EDC-09536		
φ 9.5 ~ 10.0	—	EDC-1024	EDC-1028	EDC-1036		
φ 10.0 ~ 10.5	—	EDC-10524	EDC-10528	EDC-10536		
φ 10.5 ~ 11.0	—	EDC-1124	EDC-1128	EDC-1136		
φ 11.0 ~ 11.5	—	EDC-11524	EDC-11528	EDC-11536		
φ 11.5 ~ 12.0	—	EDC-1224	EDC-1228	EDC-1236		
φ 12.0 ~ 12.5	—	—	EDC-12528	EDC-12536		
φ 12.5 ~ 13.0	—	—	EDC-1328	EDC-1336		
φ 13.0 ~ 13.5	—	—	EDC-13528	EDC-13536		
φ 13.5 ~ 14.0	—	—	EDC-1428	EDC-1436		
φ 14.0 ~ 14.5	—	—	EDC-14528	EDC-14536		
φ 14.5 ~ 15.0	—	—	EDC-1528	EDC-1536		
φ 15.0 ~ 15.5	—	—	EDC-15528	EDC-15536		
φ 15.5 ~ 16.0	—	—	EDC-1628	EDC-1636		
φ 16.0 ~ 16.5	—	—	—	EDC-16536		
φ 16.5 ~ 17.0	—	—	—	EDC-1736		
φ 17.0 ~ 17.5	—	—	—	EDC-17536		
φ 17.5 ~ 18.0	—	—	—	EDC-1836		
φ 18.0 ~ 18.5	—	—	—	EDC-18536		
φ 18.5 ~ 19.0	—	—	—	EDC-1936		
φ 19.0 ~ 19.5	—	—	—	EDC-19536		
φ 19.5 ~ 20.0	—	—	—	EDC-2036		
φ 20.0 ~ 20.5	—	—	—	EDC-20536		
φ 20.5 ~ 21.0	—	—	—	EDC-2136		
φ 21.0 ~ 21.5	—	—	—	EDC-21536		
φ 21.5 ~ 22.0	—	—	—	EDC-2236		

Diá. de zanco de cortador Cutter's shank dia.	Model - Model FDC-32B
φ 20.5 ~ 21.0	FDC-21032B
φ 21.0 ~ 21.5	FDC-21532B
φ 21.5 ~ 22.0	FDC-22032B
φ 22.0 ~ 22.5	FDC-22532B
φ 22.5 ~ 23.0	FDC-23032B
φ 23.0 ~ 23.5	FDC-23532B
φ 23.5 ~ 24.0	FDC-24032B
φ 24.0 ~ 24.5	FDC-24532B
φ 24.5 ~ 25.0	FDC-25032B
φ 25.0 ~ 25.5	FDC-25532B
φ 25.5 ~ 26.0	FDC-26032B
φ 26.0 ~ 26.5	FDC-26532B
φ 26.5 ~ 27.0	FDC-27032B
φ 27.0 ~ 27.5	FDC-27532B
φ 27.5 ~ 28.0	FDC-28032B
φ 28.0 ~ 28.5	FDC-28532B
φ 28.5 ~ 29.0	FDC-29032B
φ 29.0 ~ 29.5	FDC-29532B
φ 29.5 ~ 30.0	FDC-30032B
φ 30.0 ~ 30.5	FDC-30532B
φ 30.5 ~ 31.0	FDC-31032B
φ 31.0 ~ 31.5	FDC-31532B
φ 31.5 ~ 32.0	FDC-32032B

BT

CAT

AHO

HSK-A/E/F/C

HSK-T

C

UTS

Sistemas de
herramientado
de la serie
de máquinas
especiales
Specialized
Machine

Equipo
Relacionado
Related
Equipment

Casquillos guía
y taladro de
biselado
Bush &
Chamfering
Drill

Sub Holder

Tapping Chuck

Tap Adapter

Adjustable
Adapter

Endmill Chuck

Straight Drill
Chuck

Floating Holder

EDC

Ejemplo para Ordenar - Ordering Example

EDC - 065 19

Diá. Máximo de sujeción Series 19
Max. chucking dia. 19 Series

FDC-07A

Ejemplo para Ordenar - Ordering Example

FDC - 060 07 A

Diá. Máximo de sujeción Series 07 Precisión
Max. chucking dia. 07 Series Accuracy

FDC-32A

Ejemplo para Ordenar - Ordering Example

FDC - 310 32 B

Diá. Máximo de sujeción Series 32 Precisión
Max. chucking dia. 32 Series Accuracy

Dimensión de la boquilla EDC
EDC Collet Dimension

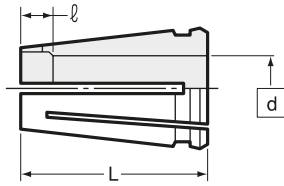

Boquilla Collet	EDC- \square d 19				EDC- \square d 24				EDC- \square d 28						EDC- \square d 36											
Tuerca ciega Nut	KDP-1916				KDP-2422				KDP-2825						KDP-3632											
L	25		20		25		30		25		40		30		25		45		40							
\square d, l	\square d	l	\square d	l	\square d	l	\square d	l	\square d	l	\square d	l	\square d	l	\square d	l	\square d	l	\square d	l						
	3.0	7.0	5.0	4.5	8.5	0	3.0	7.0	4.5	11.5	4.2	7.0	4.5	18.5	12.5	4.5	14.5	0	4.2	4.0	4.5	23.5	12.5	7.0	20.5	0
	3.3	7.0	5.5	4.0	9.0	0	3.3	7.0	5.0	9.5			5.0	16.5	13.0	4.0	15.0	0			5.0	21.5	13.0	6.5	21.0	0
	3.6	7.0	6.0	4.0			3.6	7.0	5.5	9.0			5.5	16.0	13.5	0	15.5	0			5.5	21.0	13.5	6.0	21.5	0
	3.9	7.0	6.5	4.0			3.9	7.0	6.0	8.5			6.0	13.0	14.0	0	16.0	0			6.0	17.0	14.0	6.0	22.0	0
	4.2	7.0	7.0	4.0			4.2	7.0	6.5	8.0			6.5	13.0							6.5	17.0	14.5	5.5		
	4.5	6.5	7.5	4.0					7.0	5.0			7.0	13.0							7.0	15.0	15.0	5.0		
			8.0	0					7.5	5.0			7.5	13.0							7.5	15.0	15.5	5.0		
									8.0	5.0			8.0	11.5							8.0	15.0	16.0	5.0		
									8.5	5.0			8.5	10.5							8.5	15.0	16.5	5.0		
									9.0	5.0			9.0	10.5							9.0	15.0	17.0	5.0		
									9.5	4.5			9.5	10.0							9.5	14.5	17.5	5.0		
									10.0	4.5			10.0	10.0							10.0	11.5	18.0	4.0		
									10.5	4.0			10.5	5.0							10.5	11.0	18.5	4.0		
									11.0	4.0			11.0	5.0							11.0	10.5	19.0	4.0		
									11.5	4.0			11.5	5.0							11.5	10.0	19.5	4.0		
									12.0	0			12.0	4.5							12.0	10.0	20.0	0		

Rangos de contracción permitida: 0.3 mm para diámetros de 4.5 d o menores.
0.5 mm para diámetros de 5.0 d o mayores.

Shrinkage Allowance : 0.3mm for d 4.5 or smaller.
0.5mm for d 5.0 or bigger.

Dimensión de la tuerca ciega KDP
KDP Nut Dimension

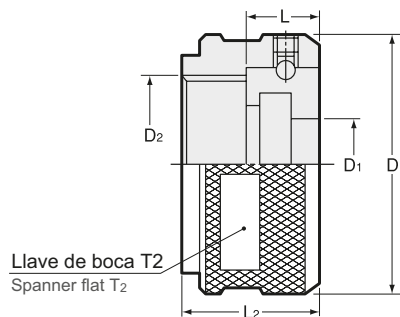

Código Code	Modelo Model	Boquilla Collet	D	D1	D2	L	L2	T2
0070 00001916	KDP -1916	EDC- \square d19	26	10	M19 P=1	6.7	14	24
0070 00002422	KDP -2422	EDC- \square d24	32	12.5	M24 P=1	7.2	15	30
0070 00002825	KDP -2825	EDC- \square d28	36	16.5	M28 P=1	7.5	15	33
0070 00003632	KDP -3632	EDC- \square d36	46	23	M36 P=1	10.0	18.5	42

Combinación de accesorios Accessories combination

Boquilla Collet		Tuerca ciega Nut		Llave Inglesa Spanner	
Código Code	Modelo Model	Código Code	Modelo Model	Código Code	Modelo Model
2480 0120 ※※ 07	FDC-07A	0070 01001407	KDP-1414	—	Llave con 17mm de ancho Flat 17mm width
0070 000190 ※※	EDC-19	0070 00001916	KDP-1916	0803 00000011	S-1L
0070 00024 ※※※	EDC-24	0070 00002422	KDP-2422	0803 00000013	S-3L
0070 00028 ※※※	EDC-28	0070 00002825	KDP-2825	0803 00000014	S-4L
0070 00036 ※※※	EDC-36	0070 00003632	KDP-3632	0803 00000015	S-5L
2480 003 ※※※ 32	FDC-32B	2544 00000032	HDP-32	0803 00000006	S-6

Llave Inglesa Spanner

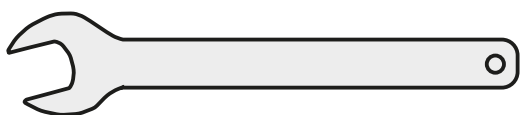

Usar llaves inglesas NT con los productos NT previene el apriete excesivo y la ruptura de las tuercas ciegas. Como las llaves planas inglesas NT se hicieron con las especificaciones de NT, una llave convencional podría no ajustarse adecuadamente en los productos NT.

Use of NT spanners on NT products prevent over-tightening and breakage.

As NT spanner flats are made to NT specifications, conventional spanner may not fit properly on NT products.

Inserción y extracción de la boquilla Collet insertion and removal

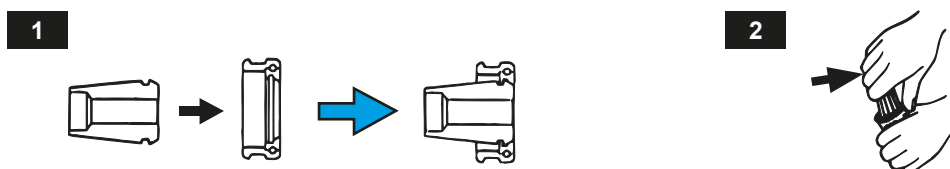

1. Para insertar

Coloque la boquilla EDC dentro del extremo roscado de la tuerca ciega KDP. Presione la parte trasera de la boquilla hacia abajo para que embone la boquilla dentro de la tuerca ciega KDP.

2. Para desmontar

Mientras sostiene firmemente con una mano la tuerca ciega KDP, sujete la boquilla EDC con la otra mano mientras empuja hacia un costado.

1. To insert

Place EDC collet into threaded end of KDP nut. Press down on rear of the collet to "clip" the collet into the nut.

2. To remove

While holding KDP nut firmly in one hand grasp EDC collet in the other while pushing sideways.

Dimensiones para la boquilla y la tuerca ciega
Dimension for Collet and Nut

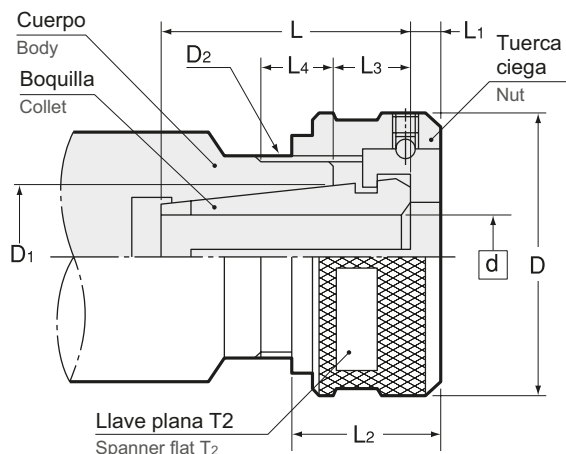

Boquilla Collet	Tuerca ciega Nut	Llave Inglesa Spanner	d	D	D1	D2	L	L1	L2	L3	L4 MIN	T2
EDC -d 19	KDP-1916	S-1L	2.8 ~ 9	26	13.73	M19 P=1	(25)	2.5	14	3.5 ~ 7.0	8	24
EDC -d 24	KDP-2422	S-3L	2.8 ~ 12	32	18.59	M24 P=1	(30)	3.0	15	3.5 ~ 7.0	8	30
EDC -d 28	KDP-2825	S-4L	3.9 ~ 16	36	22.3	M28 P=1	(40)	3.0	15	4.0 ~ 7.5	8	33
EDC -d 36	KDP-3632	S-5L	3.9 ~ 22	46	30.6	M36 P=1	(45)	4.3	18.5	5.5 ~ 9.0	10	42

La dimensión de "L" varia dependiendo de la medida de cada boquilla.
L dimension varies from size to size.

Dimensiones del cuerpo
Dimension for body

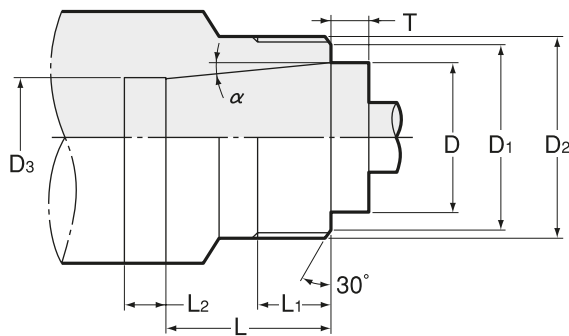

Boquilla Collet	Tuerca ciega Nut	D	T ±0.1	D1	D2	D3	L	L1 MIN	(L2)	α
EDC -d 19	KDP-1916	13.73	4.24	18	M19 P=1	(10.8)	21	8	(6.0)	5° 59'
EDC -d 24	KDP-2422	18.59	4.19	23	M24 P=1	(14.8)	26	8	(6.6)	5° 59'
EDC -d 28	KDP-2825	22.3	4.52	27	M28 P=1	(18.5)	35.5	8	(10)	5° 59'
EDC -d 36	KDP-3632	30.6	5	35	M36 P=1	(24.8)	39	10	(10)	5° 59'

Las dimensiones "D3" y "L2" son solamente como referencia y podrían cambiar dependiendo del diseño de la pieza.
Contáctenos para obtener el calibrador de ahusamiento.

D3 and L2 are for reference only and can be changed to your designing.
Contact us for taper gauge.

Sello contra polvo - Dust Seal

- Al instalar un sello de polvo en la tuerca, se previene el ingreso de virutas a la tuerca ciega. Para insertar el sello contra polvo, aplique un poco de adhesivo en la tuerca y presiona el sello contra polvo en la tuerca ciega para colocarlo en la posición correcta.
- By installing a dust seal into nut, chips are prevented from entering. To insert dust seal, apply some adhesive to nut and press down on the dust seal to snap it into place.

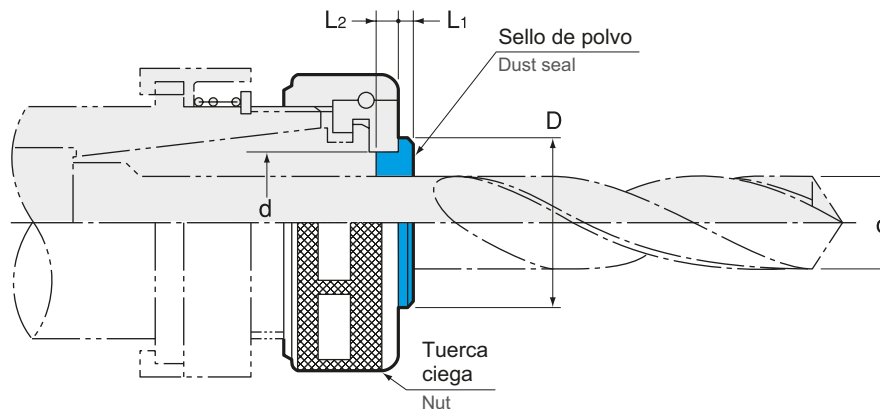

Aplicable únicamente en la serie KDP y en la tuerca ciega HDP32.
Applicable only for KDP series and HDP32 nut.

Código Code	Boquilla Collet	Tuerca ciega Nut	Boquilla Collet	d	D	d	L1	L2
0071 00009 ※※※	DS9-d	KDP-1916	EDC-19	2.8 ~ 9	15	10	1.5	2.3
0071 00012 ※※※	DS12-d	KDP-2422	EDC-24	2.8 ~ 11.5	18	12.5	1.5	2.7
0071 00016 ※※※	DS16-d	KDP-2825	EDC-28	4.0 ~ 15.5	22	16.5	2	2.7
0071 00022 ※※※	DS22-d	KDP-3632	EDC-36	4.0 ~ 22	30	23	2	4
0071 00032 ※※※	DS32-d	HDP-32	FDC-32B	20.0 ~ 32	40	33	2	4

- 1.El diámetro del zanco de una herramienta de corte se insertará en " ※※※ ". El código de producto del DS16-12.0 será 0071 00016120.
- 2.Al hacer su orden, favor de especificar el diámetro del zanco de la herramienta.

- 1.Shank diameter of a cutting tool will be inserted in " ※※※ ". Product code for DS16-12.0 will be 0071 00016120 .
- 2.When ordering, please specify tool shank diameter.

Ejemplo para Ordenar - Ordering Example

DS	16	-	12.0
Sello contra polvo	Máx. Diámetro Interno de boquilla		Diá. del zanco de la herramienta a utilizar
dust seal	Max. collet size		Tool shank dia. in use

Dimensión del zanco ajustable (estándar DIN)

Dimension for Adjustable Shank (DIN Standard)

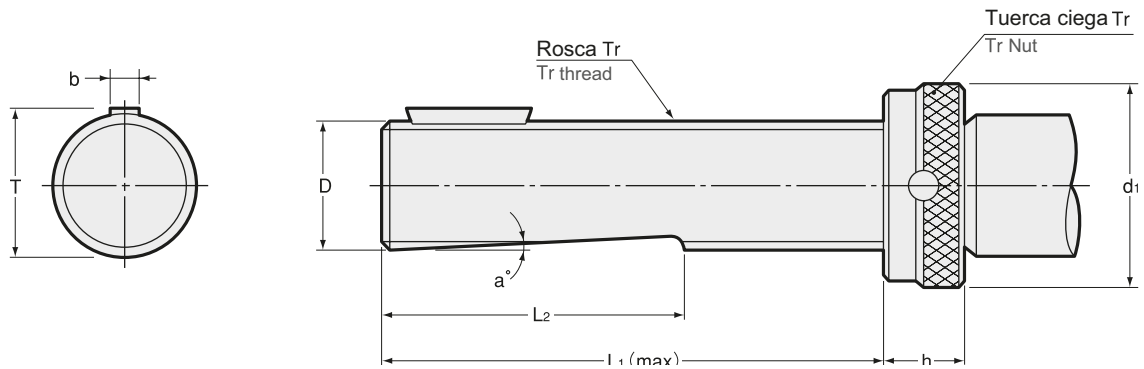

Medida de rosca Tr Tr thread size	D h6	d1	T	b h9	L1	L2	h	a°
Tr.16×1.5	16	25	17.1 ⁰ _{-0.25}	5	73	43	12	2
Tr.20×2	20	32	21.1 ⁰ _{-0.25}	5	76	46	12	2
Tr.28×2	28	40	29.5 ⁰ _{-0.25}	6	83	51	12	2
Tr.36×2	36	50	37.5 ⁰ _{-0.35}	8	104	65	14	2
Tr.48×2	48	67	49.9 ⁰ _{-0.35}	10	126	76	18	2

Dimensión del husillo DIN

DIN Spindle Dimension

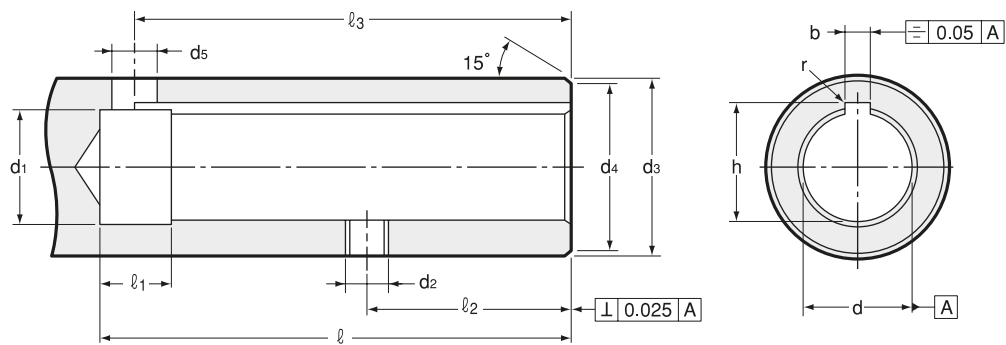

Medida Size	d H6	ℓ (min)	d1	d2	d3 g6	d4	d5	ℓ1	ℓ2 ±0.1	ℓ3	b	h +0.1 0	r
16	16	74	16.6	M6	25	24	6	8	34	70	5 ^{+0.145} _{+0.070}	17.3	0.2
20	20	77	20.6	M6	32	31	6	8	34	73	5 ^{+0.145} _{+0.070}	21.3	0.2
28	28	85	28.6	M8	40	39	8	10	38	80	6 ^{+0.145} _{+0.070}	29.7	0.4
36	36	106	36.8	M8	50	49	10	10	45	101	8 ^{+0.170} _{+0.080}	37.7	0.4
48	48	129	48.8	M10	67	66	12	12	57	123	10 ^{+0.170} _{+0.080}	50.1	0.4

Quick Change Stub Tapper

Aplicaciones Applications	Características Features
------------------------------	-----------------------------

- Suministro a través del husillo: Suministro de inclinación.
- Diseñado para usarse en máquinas de propósitos especiales, máquinas de transferencia, etc.
- Spindle Feed : Pitch Feed
- Designed for use on special-purpose machine, transfer machine etc.

- Una longitud de proyección adecuada y un zanco de diámetro pequeño hacen que su proceso de machueleado sea más estable.
- El diseño de un husillo simple hace más compacto su maquinado.
- El cojinete radial corrige las discrepancias de alineación entre el orificio, el diseño de un husillo simple hace más compacto su maquinado preperforado y el machuelo.
- Cambio rápido.
- Small shank and projection length makes your tapping job very stable.
- Simple spindle designing/machining makes your machine compact.
- Radial float corrects alignment discrepancies between pre-drilled hole and tap.
- Quick change

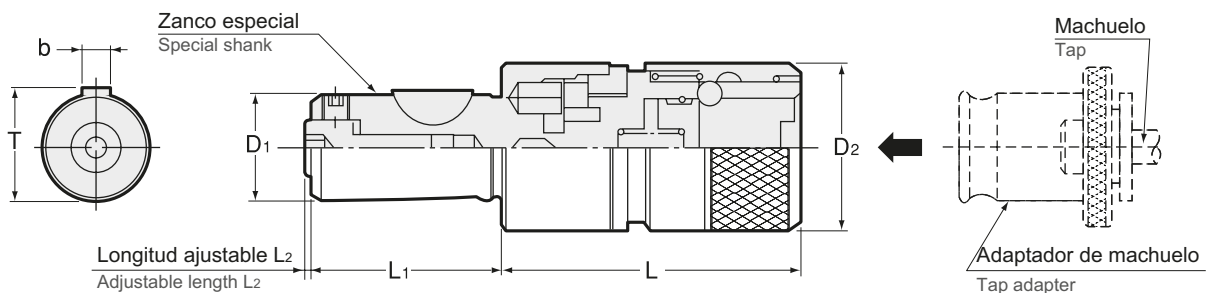

Para conocer las medidas adecuadas de machuelo, favor de dirigirse a la tabla en la pág. 484-486.
For capable tap sizes, please refer to P. 484-486 chart.

Código Code	Modelo Model	Medida de machuelo Tap Size	Medida de adaptador Adapter size	Flote radial Radial float	D1 h6	D2	L	L1 ±0.1	T	b	L2	kg
0831 00000000	KTP0	M3 ~ M8 (M10) U1/4 ~ U5/16 (U3/8)	0	0.25	16	23	54	31	17.1	5	0 ~ 2	0.2
0831 00000001	KTP1	M3 ~ M12 (M15) U1/4 ~ U7/16 (U9/16) Pipe(PT,PS,PF)1/8 ~ 1/4	1	0.5	20	32	58	37	21.1	5	0 ~ 2	0.4
0831 00000040	KTP40	M6 ~ M18 U1/4 ~ U3/4	40	0.75	28	40	78	49	29.5	6	0 ~ 2	0.8
0831 00000002	KTP2	M8 ~ M22 U3/8 ~ U7/8 Pipe(PT,PS,PF)1/8 ~ 1/2	2	1	28	50	85	49	29.5	6	0 ~ 2	1.2

1. La medida del machuelo indicada entre corchetes es sólo para machuelado ligero.
 2. El adaptador de machuelo se vende por separado.
1. Tap size in brackets are for light tapping only.
 2. Tap adapter is sold separately.

Adaptador de machuelo
Tap adapter

Pág. 480

Ejemplo para Ordenar - Ordering Example

KTP1

Medida de adaptador
Adapter size

Quick Change Stub Tapper

Aplicaciones Applications

- Suministro a través del husillo: todos los tipos de estilo de suministro. Para suministros del husillo que no sean por suministro de inclinación la compresión no debe activarse al machuelear.
- Diseñado para usarse en máquinas de propósitos especiales, máquinas transfer, máquinas roscadoras, etc.
- Spindle Feed : All kinds of feed styles. For spindle feeds other than pitch feed, compression should not be activated while tapping.
- Designed for use on special-purpose machine, transfer machine, tapping machine etc.

Características Features

- Una longitud de proyección adecuada y un zanco de diámetro pequeño, hacen que su proceso de machuleado sea más estable.
- El diseño de un husillo simple hace más compacto su maquinado.
- La compensación en la longitud permite que haya discrepancias de abastecimiento entre el husillo y el machuelo.
- Cambio rápido
- Small shank and projection length makes your tapping job very stable.
- Simple spindle designing/machining makes your machine compact.
- Length compensation allows for feed discrepancies between spindle and tap.
- Quick change

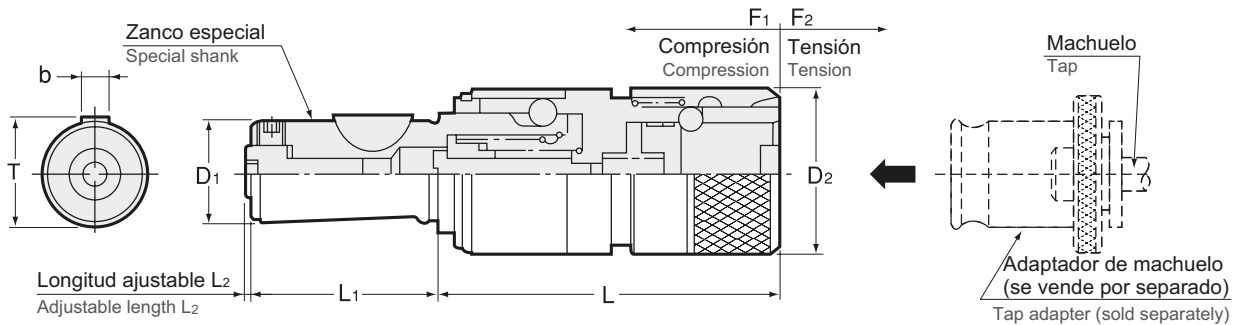

! Para conocer las medidas adecuadas del machuelo, favor de dirigirse a las tablas en las págs. 484-486.
For capable tap sizes, please refer to P. 484-486 chart.

Código Code	Modelo Model	Medida del machuelo Tap Size	Medida del adaptador Adapter size	Compensación axial Axial compensation		D1 h6	D2	L	L1 ±0.1	T	b	L2	kg
				F1 Compresión Compression	F2 Tensión Tension								
0832 0000013	KTL 013-3	M3 ~ M8 (M10) U1/4 ~ U5/16 (U3/8)	0	3	10	16	23	65	31	17.1	5	0 ~ 2	0.2
0832 00010010	010-0			0	10	16	23	65	31	17.1	5	0 ~ 2	0.2
0832 00000113	KTL 113-3	M3 ~ M12 (M15) U1/4 ~ U7/16 (U9/16)	1	3	10	20	32	70	37	21.1	5	0 ~ 2	0.4
0832 00010110	110-0	Pipe(PT,PS,PF)1/8 ~ 1/4		0	10	20	32	70	37	21.1	5	0 ~ 2	0.4
0832 00004015	KTL 4015-3	M6 ~ M18 U1/4 ~ U3/4	40	3	12	28	40	85	49	29.5	6	0 ~ 2	0.8
0832 00014012	4012-0			0	12	28	40	85	49	29.5	6	0 ~ 2	0.8
0832 00000215	KTL 215-3	M8 ~ M22 U3/8 ~ U7/8	2	3	12	28	50	95	49	29.5	6	0 ~ 2	1.2
0832 00010212	212-0	Pipe(PT,PS,PF)1/8 ~ 1/2		0	12	28	50	95	49	29.5	6	0 ~ 2	1.2

1. Las medidas del machuelo indicados entre paréntesis son sólo para machuelados ligeros.
2. En caso de que haya discrepancia en el alineamiento entre el orificio preperforado y el machuelo, use el KTLP.
3. El adaptador del machuelo se vende por separado.

1. Tap size in brackets are for light tapping only.
2. In case of alignment discrepancy between predrilled hole and tap, use KTLP.
3. Tap adapter is sold separately.

Adaptador de machuelo
Tap adapter

Pág. 480



Ejemplo para Ordenar - Ordering Example

KTL1 **13** - **3**

Medida de adaptador F1+F2=13 Compresión (F1)
Adapter size Compression(F1)

KTLP

Quick Change Stub Tapper

Aplicaciones Applications

- Diseñado para usarse en máquinas de propósitos especiales, máquina transfer, etc.
- Suministro del husillo: todos los tipos de estilo de suministro. Para suministros del husillo que no sean por suministro de inclinación use un portaherramienta de machuelado con tensión para que la compresión no funcione.
- Designed for use on special-purpose machine, transfer machine etc.
- Spindle Feed : All kinds of feed styles. For spindle feeds other than pitch feed, use a tapping chuck with tension so that compression does not work.

Características Features

- Una longitud de proyección adecuada y un zanco de diámetro pequeño hacen que su proceso de machueado sea más estable.
- El diseño de un husillo simple hace más compacto su maquinado.
- La compensación en la longitud permite que haya discrepancias de abastecimiento entre el husillo y el machuelo.
- Cambio rápido
- Small shank and projection length makes your tapping job very stable.
- Simple spindle designing/machining makes your machine compact.
- Length compensation allows for feed discrepancies between spindle and tap.
- Radial float corrects alignment discrepancies between pre-drilled hole and tap.
- Quick change

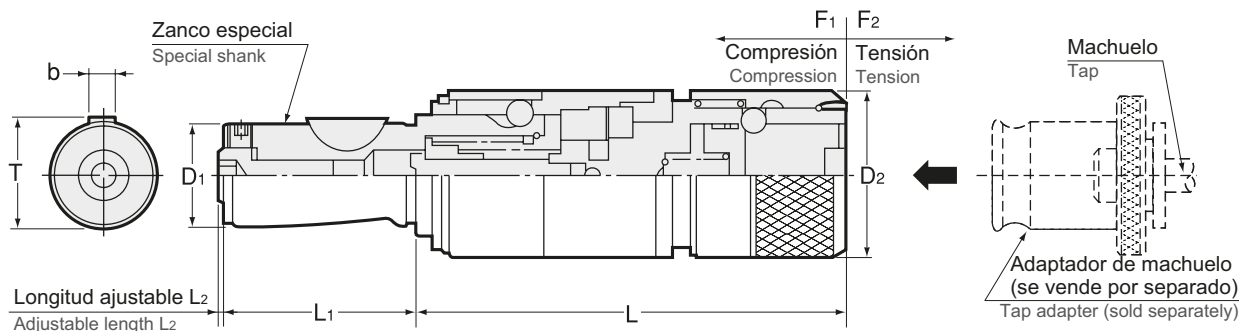

Para conocer las medidas adecuadas del machuelo, favor de dirigirse a las tablas en la pág. 484-486.
For capable tap sizes, please refer to P. 484-486 chart.

Código Code	Modelo Model	Medida de machuelo Tap Size	Medida del adaptador Adapter size	Flote radial Radial float	Compensación axial Axial compensation		D1 _{h6}	D2	L	L1 _{±0.1}	T	b	L2	kg
					F1 Compresión Compression	F2 Tensión Tension								
0833 00000013	KTLP 013-3	M3 ~ M8 (M10) U1/4 ~ U5/16 (U3/8)	0	0.25	3	10	16	23	83	31	17.1	5	0 ₂ ~ 2	0.3
0833 00010010	010-0			0.25	0	10	16	23	83	31	17.1	5	0 ₂ ~ 2	0.3
0833 00000113	KTLP 113-3	M3 ~ M12 (M15) U1/4 ~ U7/16 (U9/16)	1	0.5	3	10	20	32	85	37	21.1	5	0 ₂ ~ 2	0.5
0833 00010110	110-0	Pipe(PT,PS,PF)1/8 ~ 1/4		0.5	0	10	20	32	85	37	21.1	5	0 ₂ ~ 2	0.5
0833 00004015	KTLP 4015-3	M6 ~ M18 U1/4 ~ U3/4	40	0.75	3	12	28	40	109	49	29.5	6	0 ₂ ~ 2	1.0
0833 00014012	4012-0			0.75	0	12	28	40	109	49	29.5	6	0 ₂ ~ 2	1.0
0833 00000215	KTLP 215-3	M8 ~ M22 U3/8 ~ U7/8	2	1	3	12	28	50	119	49	29.5	6	0 ₂ ~ 2	1.6
0833 00010212	212-0	Pipe(PT,PS,PF)1/8 ~ 1/2		1	0	12	28	50	119	49	29.5	6	0 ₂ ~ 2	1.6

- Las medidas del machuelo indicadas entre paréntesis son sólo para machueados ligeros.
 - El adaptador de machuelo se vende por separado.
- Tap size in brackets are for light tapping only.
 - Tap adapter is sold separately.

Adaptador de machuelo
Tap adapter
Pág. 480

Ejemplo para Ordenar - Ordering Example

KTLP1 13 - 3

Medida de adaptador
Adapter size

F1+F2=13

Compresión (F1)
Compression(F1)



Dimensiones del husillo especial
Special Spindle Dimension

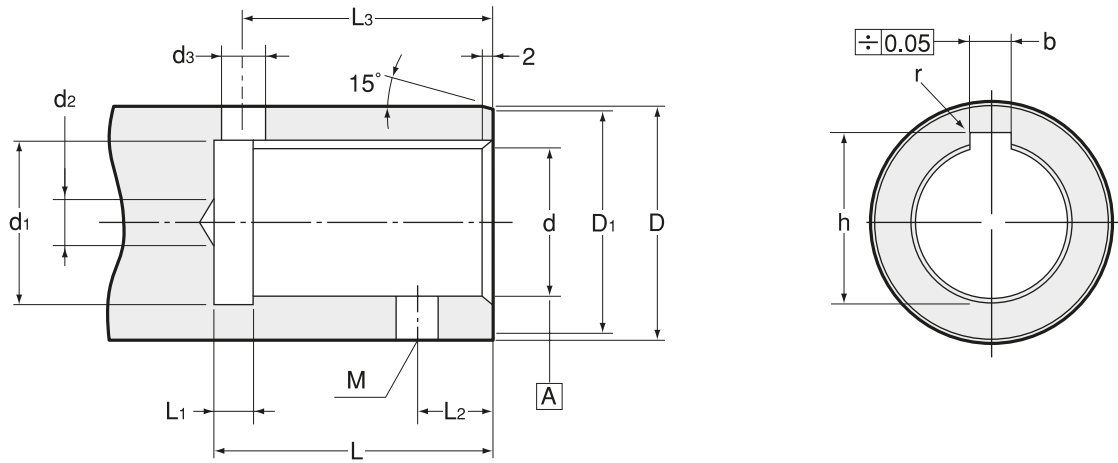

Para KTP, KTL, KTL P
For KTP, KTL, KTL P

Medida Size	d H6	L +0.5 0	d1	d2 (MAX)	D g6	D1	d3	L1	L2	M	L3	b +0.145 +0.07	h +0.1 +0	r
16	16	31	16.6	4	25	24	6	5	10	M6	27	5	17.3	0.2
20	20	37	20.6	6	32	31	6	5	10	M6	33	5	21.3	0.2
28	28	49	28.6	10	40	39	8	5	12	M8	44	6	29.7	0.4

BT
CAT
AHO
HSK-A/E/F/C
HSK-T
C
UTS

Sistemas de
herramientado
de la serie
de máquinas
especializadas
Specialized
Machine

Equipo
Relacionado
Related
Equipment

Casquillos guía
y taladro de
biselado
Bush &
Chamfering
Drill

Stub Holder

Tapping Chuck

Tap Adapter

Adjustable
Adapter

Endmill Chuck

Straight Drill
Chuck

Floating Holder

NOTAS

ADAPTADOR DE MACHUELO DE CAMBIO RÁPIDO

QUICK CHANGE TAP ADAPTER

4 modelos básicos Basic 4 Models

WE

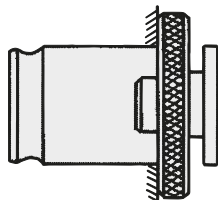

WE Cambio Rápido
Quick Change

WES · B

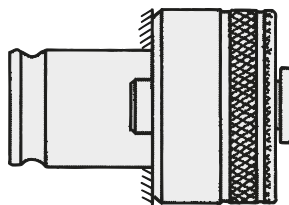

WE Cambio Rápido
Quick Change

S Torquímetro de Seguridad
Safety Torque

WEN

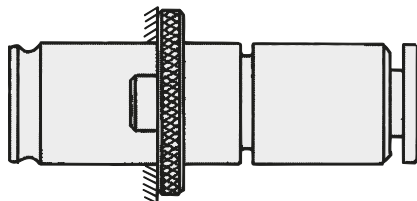

WE Cambio Rápido
Quick Change

N Ajuste Longitudinal
Length Adjustment

WESN · B

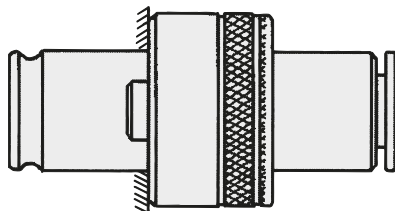

WE Cambio Rápido
Quick Change

S Torquímetro de Seguridad
Safety Torque

N Ajuste Longitudinal
Length Adjustment

Además de los 4 modelos básicos, hay una amplia variedad de modelos disponibles (medidas extendidas, medidas alargadas, tipo R para el zanco con machuelo corto, etcétera) disponibles.

In addition to the basic 4 models, wide variety of models (extended size, enlarged size, R type for short shank tap etc.) are available.

BT
CAT
AHO
HSK-A/E/F/C
HSK-T
C
UTS
Sistemas de
herramientado
de la serie
de máquinas
especializadas
Specialized
Machine

Equipo
Relacionado
Related
Equipment
Casquillos guía
y taladro de
biselado
Bush &
Chamfering
Drill

Stub Holder

Tapping Chuck

Tap Adapter

Adjustable
Adapter

Endmill Chuck

Straight Drill
Chuck

Floating Holder

WE : Cambio Rápido
WE : Quick Change

Portaherramienta y adaptador para machueado
Tapping chuck and tapping adapter

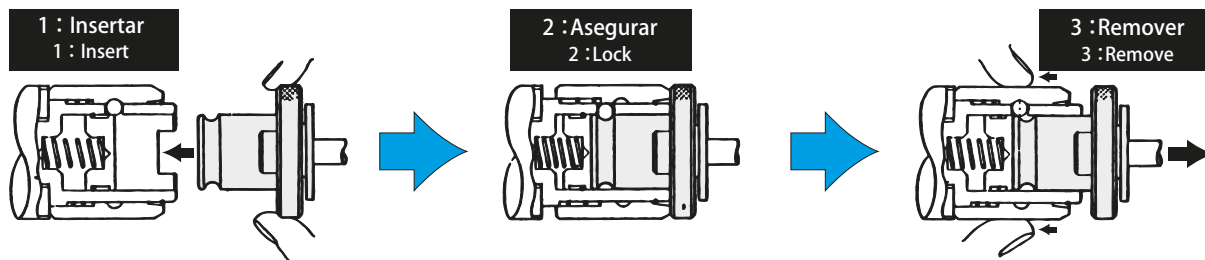

- 1: Simplemente inserte el adaptador para machuelo dentro del portaherramienta para machueado.
- 2: El portaherramienta de machueado y el adaptador para machuelo deben de estar conectados firmemente.
- 3: Mientras remueve el adaptador, presione hacia abajo la manga operacional del portaherramienta.

- 1: Simply insert tap adapter into tapping chuck.
- 2: Tapping chuck and tap adapter are connected firmly.
- 3: Push down on operation sleeve of tapping chuck while removing tap adapter.

Adaptador de machueado y machuelo
Tapping adapter and Tap

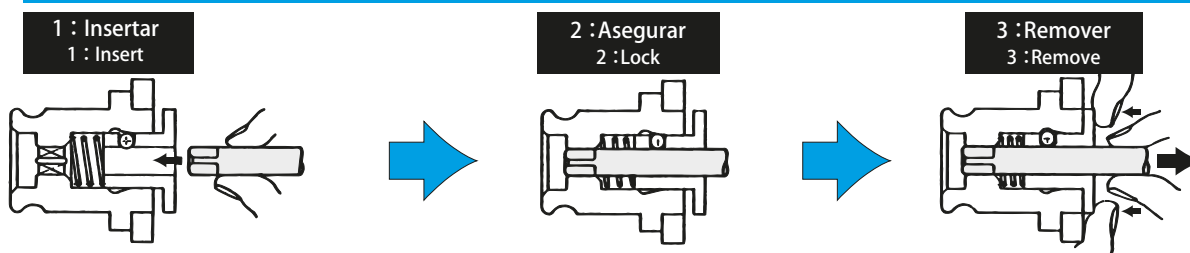

- 1: Inserte el machuelo hasta el fondo del adaptador de machuelo y gire el machuelo manualmente para conectarlos firmemente.
- 2: El machuelo y el adaptador deben de estar conectados con firmeza.
- 3: Para remover el machuelo, presione hacia abajo el casquillo esférico.

- 1: Insert tap into bottom of tap adapter, and rotate tap manually to connect them firmly.
- 2: Tap and adapter are connected firmly.
- 3: Push down on ball bush while removing tap.

S : Torquímetro de seguridad
S : Safety torque

El torquímetro de seguridad se activa para evitar que el machuelo se quiebre en caso de que se aplique más torque de lo fijado sobre el machuelo. (Úselo con un conjunto de machuelo y portaherramienta que tenga un mecanismo de compensación axial)

Safe torque device activates to prevent breakage tap when torque more than fixed amount is applied to tap. (Use with a tapper equipped with axial compensation mechanism)

Operación normal (mecanizado normal)
Normal operation (Normal machining)

Operación vacía (Torque de mecanizado anormal)
Empty operation (Abnormal machining torque)

Operación en reversa (el dispositivo de torque no se mueve en dirección reversa)
Reverse operation (Torque device doesn't move in the reverse direction)

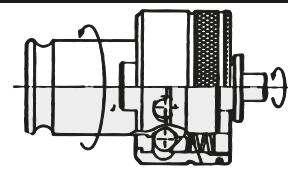
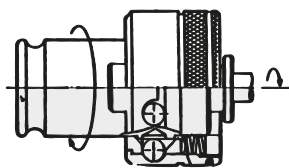
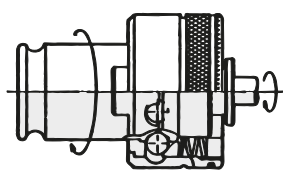

Favor de especificar cuando utilice un machuelo de rosca izquierda.

When using left handed tap adapter, please specify.

N : Ajuste longitudinal
N : Length adjustment

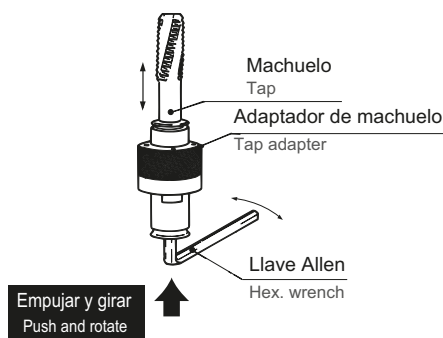

Inserte la llave Allen en la parte inferior del adaptador de machuelo y gírela para ajustar la longitud de la herramienta.
Insert hex. wrench into bottom of tap adapter and turn to adjust tool length.

El adaptador de machuelo con el mecanismo de ajuste longitudinal se recomienda utilizarce bajo las siguientes condiciones:

1. Ajuste longitudinal con el calibrador de premontaje.
 2. Cuando cambie la longitud del machuelo a causa del rectificado/reafilado.
 3. Cuando no desee usar la función N/C de compensación de la herramienta en la máquina.
- Tap adapter with tool adjustment mechanism can be recommended for following conditions.
1. Tool adjustment with presting gauge.
 2. When tap length changes due to re-grinding.
 3. When you do not want to use N/C machine tool compensation function.

BT
CAT
AHO
HSK-A/E/F/C
HSK-T
C
UTS
Sistemas de herramienta de la serie de máquinas especiales Specialized Machine
Equipo Relacionado Related Equipment
Casquillos guía y taladro de biselado Bush & Chamfering Drill
Stub Holder
Tapping Chuck
Tap Adapter
Adjustable Adapter
Endmill Chuck
Straight Drill Chuck
Floating Holder

Quick Change Tap Adapter

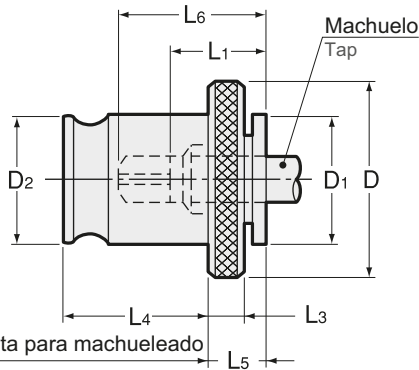

Portaherramienta para machueado

Tapping chuck

Aplicaciones Applications

- Para orificio de paso, orificio ciego, rosca derecha y rosca izquierda.
- For through hole, blind hole, right-hand thread and left-hand thread.

Características Features

- Cambio rápido
- ※ En caso de que tema quebrar el machuelo, elija un WES•B y un portaherramienta de machueado con un embrague de torque de seguridad.
- Quick Change
- ※ In case you are afraid of tap breakage, choose a WES•B and a tapping chuck with safety torque clutch.

! Para conocer qué medidas de machuelo pueden utilizarse con el adaptador, dirigirse a las tablas de las págs. 484-486.
For capable tap sizes, please refer to P. 484-486 chart.

Código Code	Modelo Model	Medida del machuelo Tap Size	Medida del portaherramienta Chuck size	D	D1	D2	L1	L3	L4	L5	kg
0210 0000 ※※※	WE0	M3 ~ M8 (M10) U1/4 ~ U5/16 (U3/8)	0	22	12.5	13	15	4	19.5	7	0.03
0210 0001 ※※※	WE1	M3 ~ M12 (M15) U1/4 ~ U7/16 (U9/16) Pipe(PT,PS,PF)1/8 ~ 1/4	1 32	30	19	19	17	4	21.5	7	0.06
0210 0004 ※※※	WE40	M6 ~ M18 U1/4 ~ U3/4	40	40	25	26	30	5	32	13	0.12
0210 0002 ※※※	WE2	M8 ~ M22 U3/8 ~ U7/8	2	48	30	31	30	5	35	11	0.25
0210 0003 ※※※	WE3	M26 ~ M38 U1 ~ U1 3/8	3	70	47	48	44	6	55.5	14	0.8
—	WE4	7/8 ~ 1-3/4 M22 ~ M48	4	90	60	60	71	13	63	42	

1. Las medidas de machuelo mostradas entre paréntesis son sólo para machueados ligeros.
2. Calcule la longitud de proyección del machuelo a partir de la dimensión L1.
3. Las dimensiones L1 y L6 varían junto con las medidas del machuelo. Siempre considere un margen de ± 1.5 mm.
4. Dirijase a la pág. 484 para conocer el diámetro del zanco del machuelo y las dimensiones del cuadro del machuelo.

1. Tap sizes in brackets are for light tapping only.
2. Calculate tap projection length from L1 dimension.
3. L1 and L6 dimensions fluctuate with tap sizes. Always take into account ± 1.5 mm allowance.
4. Refer to P.484 for tap shank dia. and square dimension.

Ejemplo para Ordenar - Ordering Example

WE1

M8J

Medida de adaptador
Adapter size

Medida de machuelo
Tap size

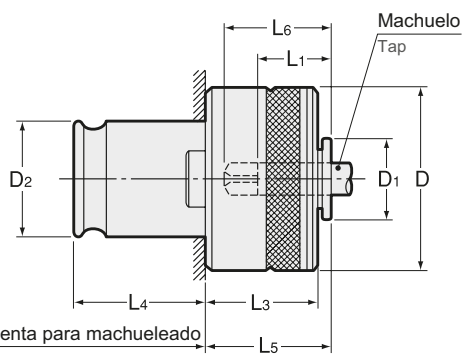

Aplicaciones

Applications

- Sólo para machuelo de rosca derecha. Orificio de paso y orificio ciego.
- For right-hand thread only. Through hole and blind hole.

Características

Features

- Cambio rápido
- El embrague de torque de seguridad actúa para evitar que el machuelo se quiebre cuando se aplique más torque que lo fijado sobre el machuelo. En este caso, un portaherramienta para machueado con un sistema de compresión debe utilizarse en conjunto.
- Quick Change
- Safety torque clutch actuates to prevent tap breakage when an excessive torque is applied to tap. In this case, a tapping chuck with compression device should be used together.



Para conocer qué medidas de machuelo pueden utilizarse con el adaptador, dirigirse a las tablas de las págs. 484-486.

For capable tap sizes, please refer to P. 484-486 chart.

Código Code	Modelo Model	Medida del machuelo Tap Size	Medida del portaherramienta Chuck size	D	D1	D2	L1	L3	L4	L5	kg
0210 06000 ※※※	WES0B	M3 ~ M8 (M10) U1/4 ~ U5/16 (U3/8)	0	23	12.5	13	15	20	19.5	21	0.06
0210 06001 ※※※	WES1B	M3 ~ M12 (M15) U1/4 ~ U7/16 (U9/16) Pipe(PT,PS,PF)1/8 ~ 1/4	1 32	32	19	19	17	25	21.5	25	0.15
0210 06040 ※※※	WES40B	M6 ~ M18 U1/4 ~ U3/4	40	40	25	26	30	27	32	30	0.3
0210 06002 ※※※	WES2B	M8 ~ M22 U3/8 ~ U7/8	2	50	30	31	30	31	35	33	0.6
0210 06003 ※※※	WES3B	M26 ~ M38 U1 ~ U1 3/8	3	72	47	48	44	41	55.5	45	1.5
—	WES4B	7/8 ~ 1-3/4 M22 ~ M48	4	95	60	60	71	61	63	68	

1. Las medidas del machuelo mostradas entre paréntesis son sólo para machueados ligeros.
2. Calcule la longitud de proyección del machuelo a partir de la dimensión L1.
3. El portaherramienta para machueado y el dispositivo de compresión deben utilizarse juntos.
4. Cuando use un machuelo para rosca de tubo especifique PT, PS o PF, ya que cada una de estas iniciales tiene un valor de torque de seguridad diferente.
5. Las dimensiones L1 y L6 varían junto con las medidas de machuelo. Siempre considere un margen de ± 1.5 mm.
6. Dirijase a la pág. 484 para conocer el diámetro del zanco del machuelo y las dimensiones del cuadro del machuelo.

1. Tap sizes in brackets are for light tapping only.
2. Calculate tap projection length from L1 dimension.
3. Tapping chuck with compression device should be used together.
4. Specify PT, PS or PF when using a pipe tap, as each of them has various safety torque value.
5. L1 and L6 dimensions fluctuate with tap sizes. Always take into account ± 1.5 mm allowance.
6. Refer to P.484 for tap shank dia. and square dimension.

Ejemplo para Ordenar - Ordering Example

WES1B

M8J

Medida de adaptador
Adapter size

Medida de machuelo
Tap size

Quick Change Tap Adapter

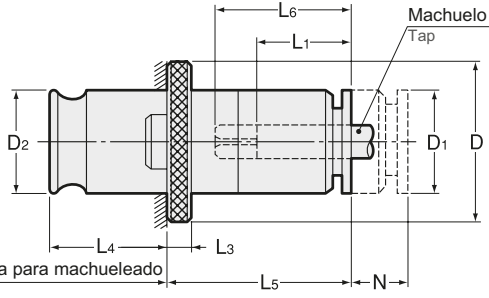

Portaherramienta para machueleado
Tapping chuck

Aplicaciones Applications

- Para orificio de paso, orificio ciego, rosca derecha y rosca izquierda.
- For through hole, blind hole, right-hand thread and left-hand thread.

Características Features

- Cambio Rápido
- El ajuste de longitud facilita el control de profundidad del machuelo para el rectificad.
- Quick Change
- Length adjustment facilitates your depth control of re-ground tap.

! Para conocer qué medidas de machuelo pueden utilizarse con el adaptador, dirigirse a las tablas de las págs. 484-486.
For capable tap sizes, please refer to P. 484-486 chart.

Código Code	Tipo Type	Medida del machuelo Tap Size	Medida del portaherramienta Chuck size	N	D	D1	D2	L1	L3	L4	L5
—	WEN0	M3 ~ M8(M10) U1/4 ~ U5/16 (U3/8)	0	8	22	13	13	15	4	19.5	29
—	WEN1	#0-12, 1/4 - 1/2 M3-M12	1	10	30	19	19	17	4	21.5	34
—	WEN2	5/16 - 7/8 M8-M20	2	15	48	30	31	30	5	35	60
—	WEN3	13/16 - 1-3/8 M14-M33	3	25	70	48	48	44	6	55.5	83

1. Las medidas de machuelo mostradas entre paréntesis son sólo para machueleados ligeros.
2. Calcule la longitud de proyección del machuelo a partir de la dimensión L1.
3. Las dimensiones L1 y L6 varían junto con las medidas del machuelo. Siempre considere un margen de ± 1.5 mm.
4. Diríjase a la pág. 484 para conocer el diámetro del zanco del machuelo y las dimensiones del cuadro del machuelo.

1. Tap sizes in brackets are for light tapping only.
2. Calculate tap projection length from L1 dimension.
3. L1 and L6 dimensions fluctuate with tap sizes. Always take into account ± 1.5mm allowance.
4. Refer to P.484 for tap shank dia. and square dimension.

Ejemplo para Ordenar - Ordering Example

WEN1	M11
Medida de adaptador Adapter size	Medida de machuelo Tap size

WESN • B

Quick Change Tap Adapter

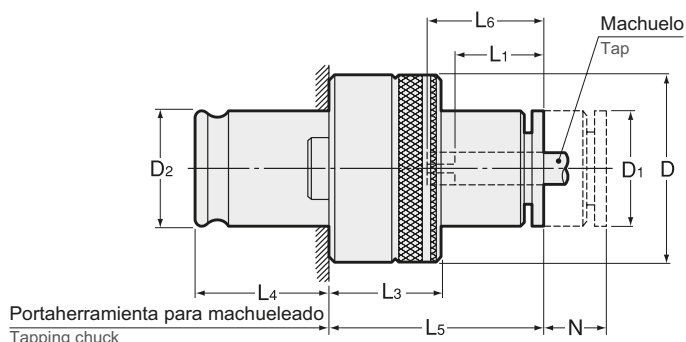

Aplicaciones

Applications

- Sólo para machuelo de rosca derecha. Orificio de paso y orificio ciego.
- For right-hand thread only. Through hole and blind hole.

Características

Features

- Cambio rápido
- El embrague de torque de seguridad actúa para evitar que el machuelo se quiebre cuando se aplique más torque que lo fijado sobre el machuelo. En este caso, un portaherramienta para machueleado con un sistema de compresión se deben usar juntos.
- El ajuste de longitud facilita el control de profundidad del machuelo para el rectificado.
- Quick Change
- Safety torque clutches actuate to prevent tap breakage when an excessive torque is applied to tap. In this case, a tapping chuck with compression device should be used together.
- Length Adjustment facilitates your depth control of re-ground tap.



Para conocer qué medidas de machuelo pueden utilizarse con el adaptador, dirigirse a las tablas de las págs. 448-450.

For capable tap sizes, please refer to P. 448-450 chart.

Código Code	Modelo Model	Medida del machuelo Tap Size	Medida del portaherramienta Chuck size	N Longitud ajustable Adjustable length	D	D1	D2	L1	L3	L4	L5	kg
0210 06100 ※※※	WESN0B	M3 ~ M8 (M10) U1/4 ~ U5/16 (U3/8)	0	8	23	13	13	15	20	19.5	28	0.1
0210 06101 ※※※	WESN1B	M3 ~ M12 (M15) U1/4 ~ U7/16 (U9/16) Pipe(PT,PS,PF)1/8 ~ 1/4	1 32	10	32	19	19	17	25	21.5	33	0.2
0210 06140 ※※※	WESN40B	M6 ~ M18 U1/4 ~ U3/4	40	15	40	25	26	30	27	32	53	0.4
0210 06102 ※※※	WESN2B	M8 ~ M22 U3/8 ~ U7/8	2	15	50	30	31	30	31	35	59	0.7
0210 06103 ※※※	WESN3B	M26 ~ M38 U1 ~ U1 3/8	3	25	72	48	48	44	41	55.5	82.5	2.1

1. Las medidas de machuelo mostradas entre paréntesis son sólo para machueleados ligeros.
2. Calcule la longitud de proyección del machuelo a partir de la dimensión L1.
3. El portaherramienta para machueleado y el dispositivo de compresión deben utilizarse juntos.
4. Cuando use un machuelo de tubo especifique PT, PS o PF, ya que cada una de estas iniciales tiene un valor de torque de seguridad diferente.
5. Las dimensiones L1 y L6 varían junto con las medidas de machuelo. Siempre considere un margen de ± 1.5 mm.
6. Dirijase a la pág. 484 para conocer el diámetro del zanco del machuelo y las dimensiones del cuadro del machuelo.

1. Tap sizes in brackets are for light tapping only.
2. Calculate tap projection length from L1 dimension.
3. Tapping chuck with compression device should be used together.
4. Specify PT, PS or PF when using a pipe tap, as each of them has various safety torque value.
5. L1 and L6 dimensions fluctuate with tap sizes. Always take into account ± 1.5 mm allowance.
6. Refer to P.484 for tap shank dia. and square dimension.

Ejemplo para Ordenar - Ordering Example

WESN2B

M12J

Medida de adaptador
Adapter size

Medida de machuelo
Tap size

WEC , WERC

Quick Change Tap Adapter (For Carbide Tap)

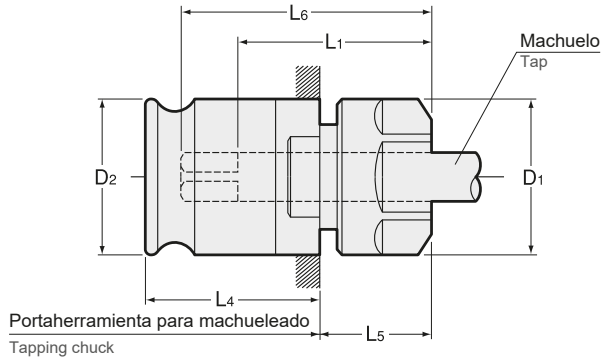

Aplicaciones Applications

- Todos los trabajos de machuelado deben utilizar machuelo de carburo.
- All tapping jobs by using carbide taps.

Características Feature

- El zanco del machuelo debe estar sujetado con firmeza por la boquilla.
- Tap shank is firmly clamped by collet.

La medida del machuelo esta basado en el antiguo estándar JIS.
Tap sizes are based on old JIS standard.

Código Code	Modelo Model	Medida de machuelo Tap Size	Medida del portaherramienta Chuck size	D1	D2	L1	L4	L5	Llave Inglesa Spanner	Torque de sujeción recomendado (N·m) Recommended clamping torque (N·m)	kg
3020 0000 ※※※	WEC0	M3 ~ M8 (M10) U1/4 ~ U5/16 (U3/8)	0	19	13	21.5	19.5	13.5	Llave con 17 mm de ancho Flat 17mm width	15 ~ 20	0.1
3020 0001 ※※※	WEC1	M4 ~ M10 U1/4 ~ U3/8	1 32	19	19	23.5	21.5	13.5	Llave con 17 mm de ancho Flat 17mm width	15 ~ 20	0.1
3020 0001 ※※※	WEC1	M11 ~ M12 U7/16 ~ U1/2 Pipe(PT,PS,PF)1/8	1 32	26	19	25	21.5	15	FK0025	30 ~ 35	0.1
3020 0002 ※※※	WEC2	M12	2	26	31	34	35	15	FK0025	30 ~ 35	0.3
3020 0002 ※※※	WEC2	M14 ~ M20 U9/16 ~ U3/4	2	34	31	35	35	16	FK0034	40 ~ 45	0.3
3020 01002 ※※※	WERC2	M7 ~ M12 U3/8 ~ U1/2 Pipe(PT,PS,PF)1/8	2	26	31	(26)	35	15	FK0025	30 ~ 35	
3020 01002 ※※※	WERC2	M14 ~ M16 U9/16	2	34	31	(29)	35	20.5	FK0034	40 ~ 45	

- Las medidas de machuelo mostradas entre paréntesis son sólo para machueledos ligeros.
 - Con respecto al tipo WERC, calcule la longitud de proyección del machuelo de la dimensión de L6 (pág. 484). Para el tipo WEC, calcular de la dimensión L1.
 - Las dimensiones L1 y L6 varían junto con las medidas del machuelo. Siempre considere un margen de ± 1.5 mm.
 - Diríjase a la pág. 484 para conocer el diámetro del zanco del machuelo y las dimensiones del cuadro del machuelo.
- Tap sizes in brackets are for light tapping only.
 - With regard to type WERC, calculate tap projection length from L6 dimension(P. 484). For type WEC, calculate from L1 dimension.
 - L1 and L6 dimensions fluctuate with tap sizes. Always take into account ± 1.5mm allowance.
 - Refer to P. 484 for tap shank dia. and square dimension.

Llave Inglesa
Spanner
Pág. 099



Ejemplo para Ordenar - Ordering Example

WEC1 M8J

Medida del adaptador Medida del machuelo

Adapter size

Tap size