

# *KSF High Precision Power Chucks*





## *Table of Contents*

Overview of Rapid Change .....	2
Overview of Precision Change .....	3
KSF/08RC Rapid Change Chucks .....	4
KSF/10RC Rapid Change Chucks .....	6
KSF/08QC Precision Change Chucks .....	8
KSF/10QC Precision Change Chucks .....	10
RC Rapid Change Top Jaws .....	12
QC Precision Change Top Jaws .....	13
RC Rapid Change Claw Top Jaws .....	14
RC Rapid Change Step Top Jaws .....	15
Chuck Lubricant .....	16
Grease Guns .....	16
Loading Rings .....	16
Spindle Data Sheet .....	17

## *Commitment to Service*

MicroCentric KSF High Precision Power Chucks are available from stock and can be adapted to any machine configuration. MicroCentric is not only committed to building the world's finest workholding products, but we also strive to provide our customers with unmatched service and support.

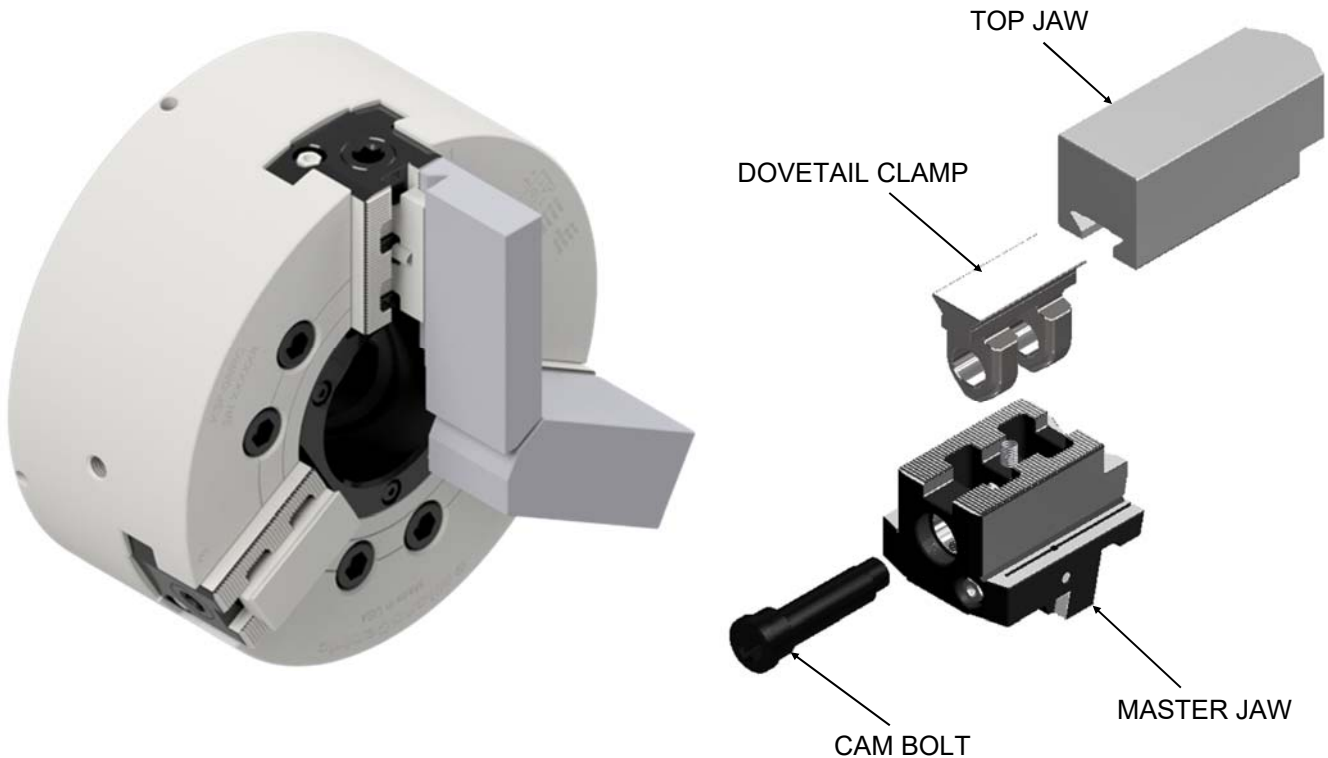

## *RC Rapid Change Jaw Locating System*

Patented RC Rapid Change jaw system only requires the top jaw to be changed, not the entire base jaw. A patented locking cam mechanism and dovetail clamp secures top jaw to the base jaw. Top jaws are located on the base jaws by  $1.5 \times 60^\circ$  serrations. This allows the top jaw to be adjusted radially increasing clamping range. Since RC top jaws are not mounted to the base jaws by cap screws so there are no counter bored holes which could interrupt the clamping diameter.

### *RC System Accuracies*

- .0004" (0.01mm) TIR max runout when top jaws are finished and replaced on same jaw location

### *RC System Design*

The RC top jaw is locked and released by a patented cam mechanism and dovetail clamp. The cam bolt is accessed on the outside surface of the base jaws. A specific torque must be applied to the cam bolt when locking the top jaw to the base jaw.

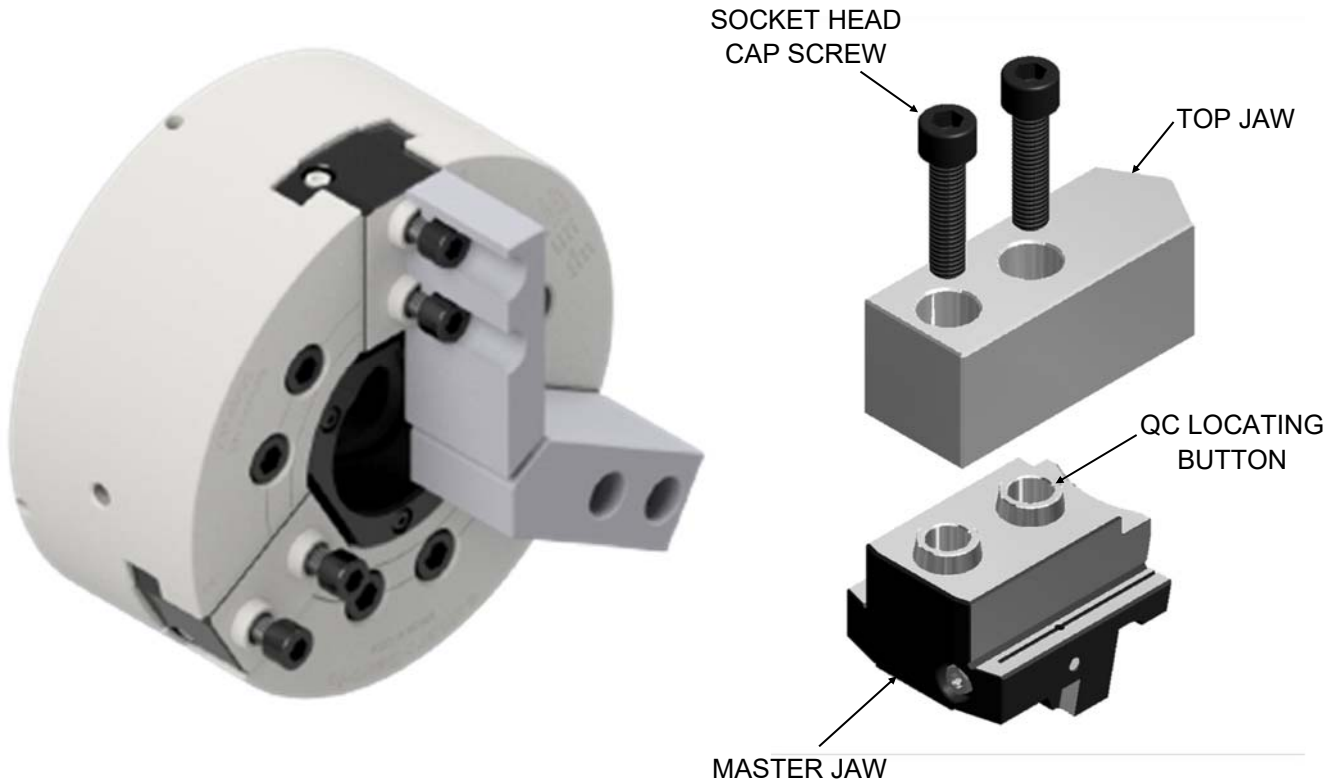

## *QC Precision Change Jaw Locating System*

Patented QC Precision Change jaw locating system reduces setup time by maintaining .0002" (0.005mm) runout after changing top jaws. MicroCentric's QC system reduces setup time by eliminating re-machining top jaws or stirring-in the chuck in order to maintain close workpiece concentricity. KSF/QC chucks are qualified so jaws can be changed between chucks and still maintain .0008" (0.02mm) TIR runout.

### *QC System Accuracies*

- .0002" (0.005mm) TIR max runout when top jaws finished and replaced on same chuck
- .0008" (.02mm) TIR max runout when top jaws finished on another QC chuck (same model)

### *QC System Design*

QC top jaws are located by two tapered buttons mounted in the master jaw. QC top jaws feature precision finished taper seats that are located by the tapered buttons. QC top jaws seat on the OD of the tapered buttons and the face of the master jaw, assuring high accuracy and rigidity.

## KSF-08/RC Rapid Change Chuck



### Features

- Patented RC Rapid Change Jaw System
- 8.25" (210mm) chuck diameter
- 2.598" (66mm) through hole
- Precision fit master jaws to minimize jaw lift
- Hardened chuck body, actuators, and master jaws, for long term accuracy and performance

### Repeating Accuracy

- .0004" (0.01mm) TIR

Chuck Model	KSF-08/RC
Jaw System	Rapid Change
Number of Jaws	3
Repeating Accuracy <sup>1</sup>	0.0004" 0.01mm
Through Hole Diameter	2.598" 66mm
Jaw Stroke (on diameter)	.299" 7.6mm
Actuator Stroke	.709" 18mm
Max Draw Tube Force	8,540 lbs 38 kN
Max Clamping Force	21,130 lbs 94 kN
Max Speed <sup>2</sup>	5,000 rpm
Chuck Weight <sup>3</sup>	52.0 lbs 23.6 kg
Moment of Inertia <sup>3</sup>	13.5 lb-ft <sup>2</sup> .57 kg-m <sup>2</sup>

1- Accuracy is the total indicator reading (radial and lateral runout) of a master gage measured 1.00" (25.4mm) from the top face of the standard top jaw at 1/2 max draw tube force.

2- With standard top jaws at max draw tube force.

3- With standard top jaws and A2-6 spindle mounting plate.

### Standard Accessories

- Blank draw tube adapter
- 1 set blank top jaws
- Chuck lubricant, and grease guns are sold separately.

### Threaded Draw Tube Adapters & Spindle Mounting Plates

- Threaded draw tube adapters are furnished on request
- A2-5, A2-6, A2-8 as well as other spindle mounting plates are available.

### KSF-08/RC Dimensions

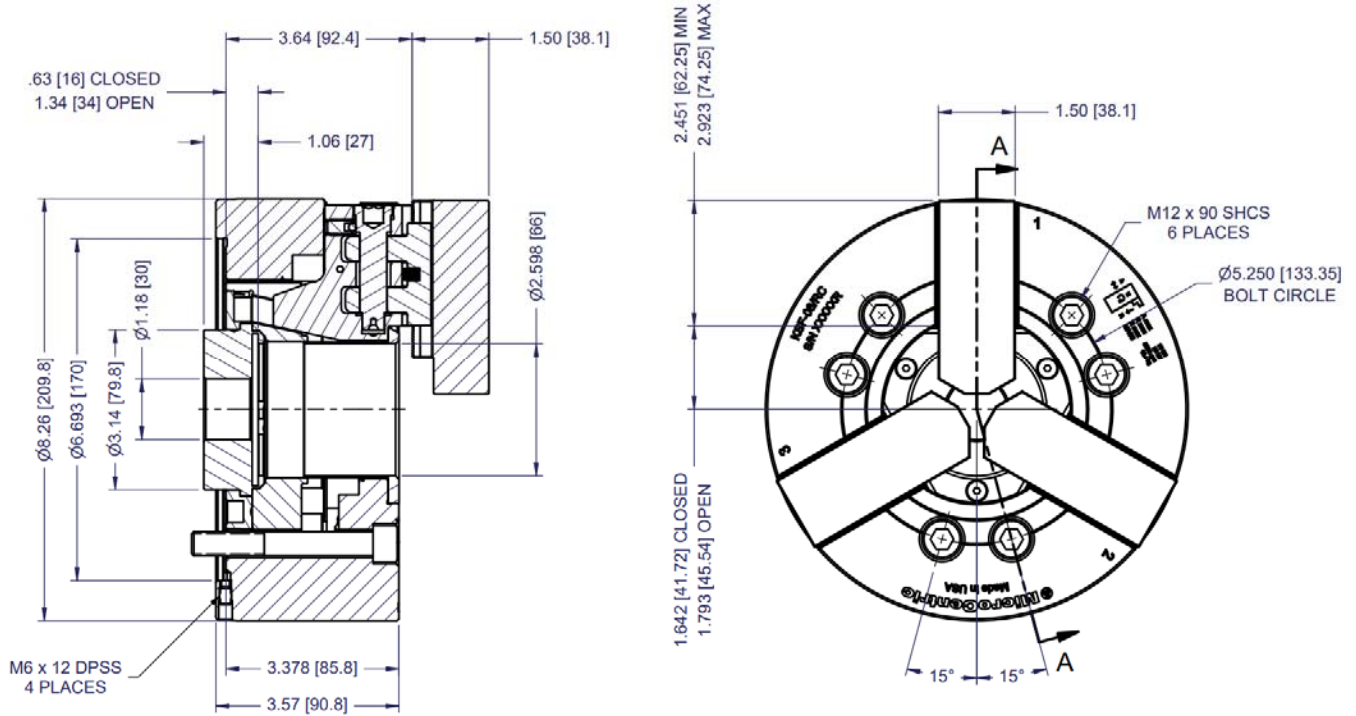

### KSF-08/RC/A6 Dimensions

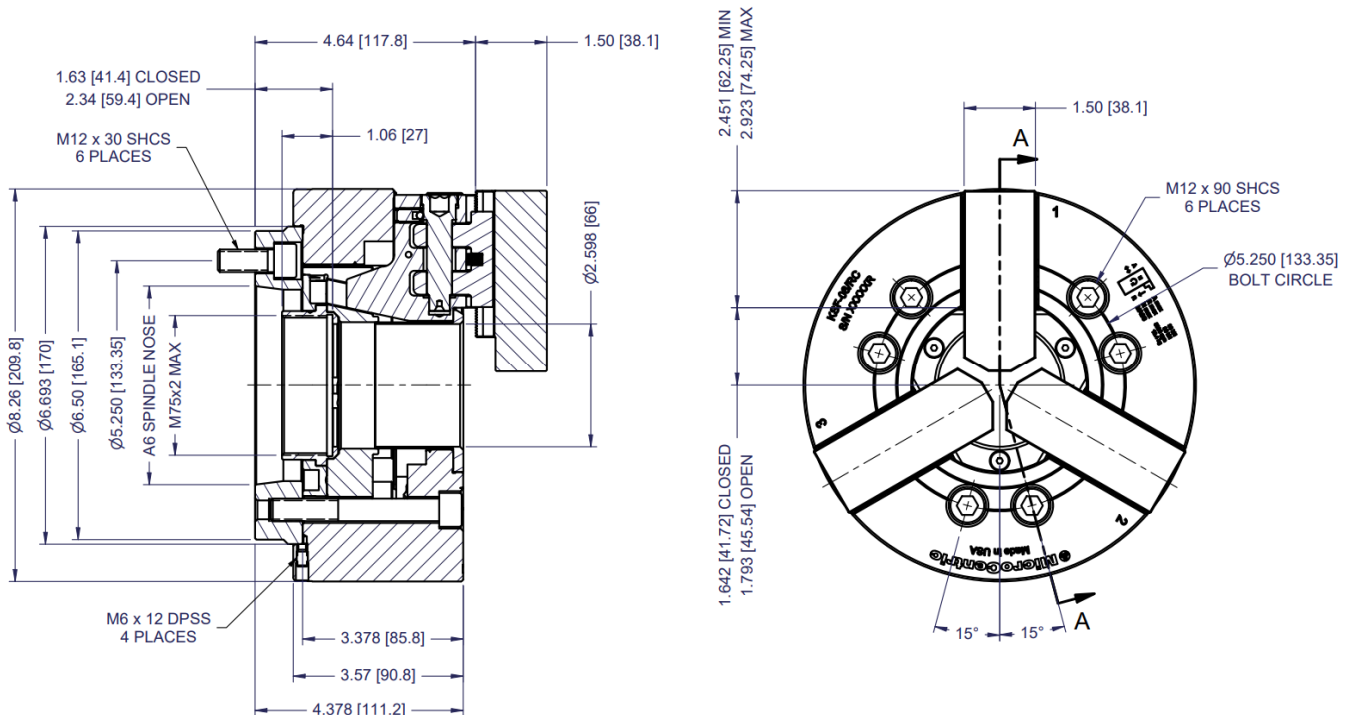

## KSF-10/RC Rapid Change Chuck



### Features

- Patented RC Rapid Change Jaw System
- 10.00" (254mm) chuck diameter
- 3.228" (82mm) through hole
- Precision fit master jaws to minimize jaw lift
- Hardened chuck body, actuators, and master jaws, for long term accuracy and performance

### Repeating Accuracy

- .0004" (0.01mm) TIR

Chuck Model	KSF-10/RC
Jaw System	Rapid Change
Number of Jaws	3
Repeating Accuracy <sup>1</sup>	.0004" .01mm
Through Hole Diameter	3.228" 82mm
Jaw Stroke (on diameter)	.335" 8.5mm
Actuator Stroke	.787" 20.0mm
Max Draw Bar Force	11,240 lbs 50 kN
Max Clamping Force	26,970 lbs 120 kN
Max Speed <sup>2</sup>	4,500 rpm
Chuck Weight <sup>3</sup>	88.2 lbs 40.0 kg
Moment of Inertia <sup>3</sup>	31.1 lb-ft <sup>2</sup> 1.31 kg-m <sup>2</sup>

1- Accuracy is the total indicator reading (radial and lateral runout) of a master gage measured 1.00" (25.4mm) from the top face of the standard top jaw at 1/2 max draw tube force.

2- With standard top jaws at max draw tube force.

3- With standard top jaws and A2-8 spindle mounting plate.

### Standard Accessories

- Blank draw tube adapter
- 1 set blank top jaws
- Chuck lubricant, and grease guns are sold separately.

### Threaded Draw Tube Adapters & Spindle Mounting Plates

- Threaded draw tube adapters are furnished on request
- A2-6, A2-8, A2-11 as well as other spindle mounting plates are available.



### KSF-10/RC Dimensions

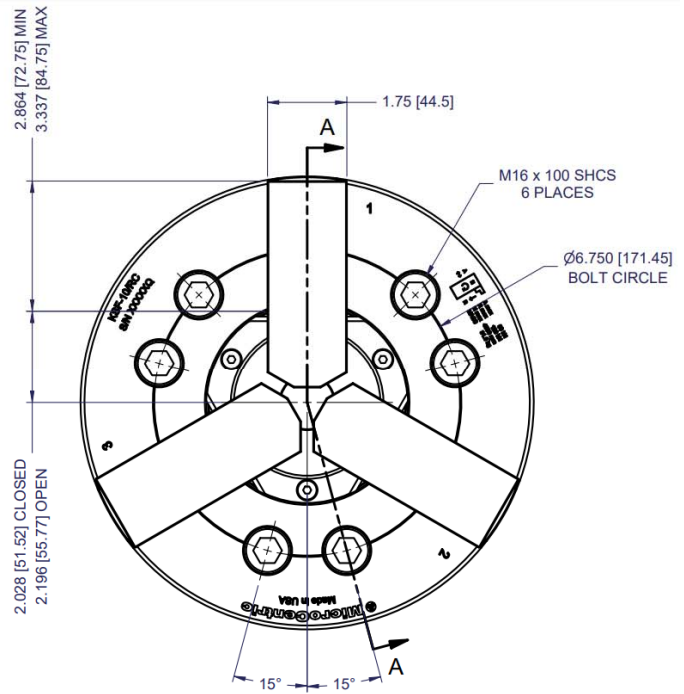
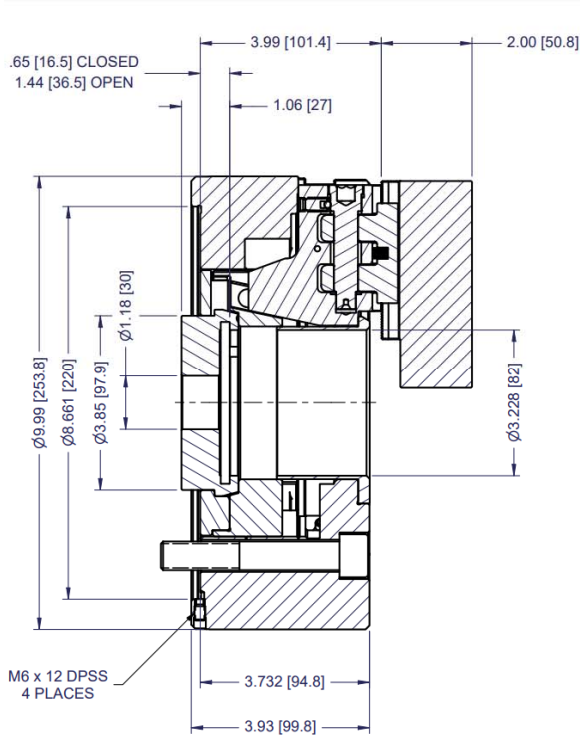

### KSF-10/RC/A8 Dimensions

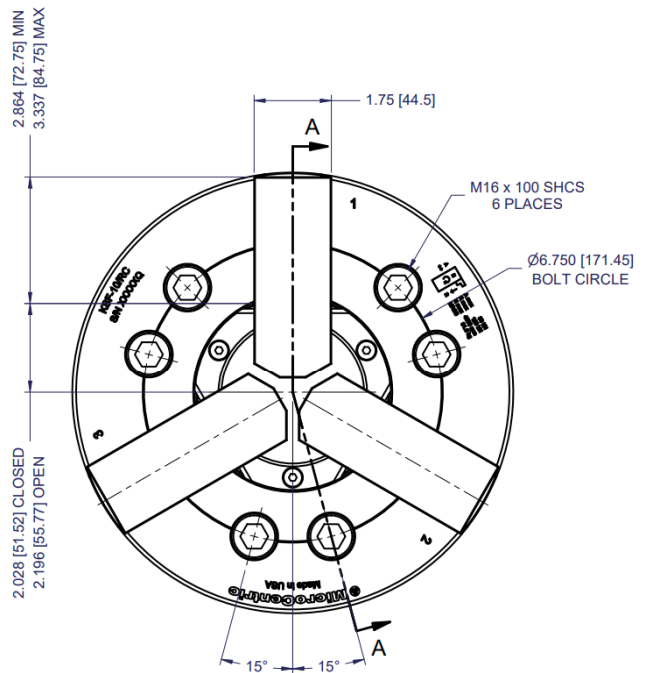
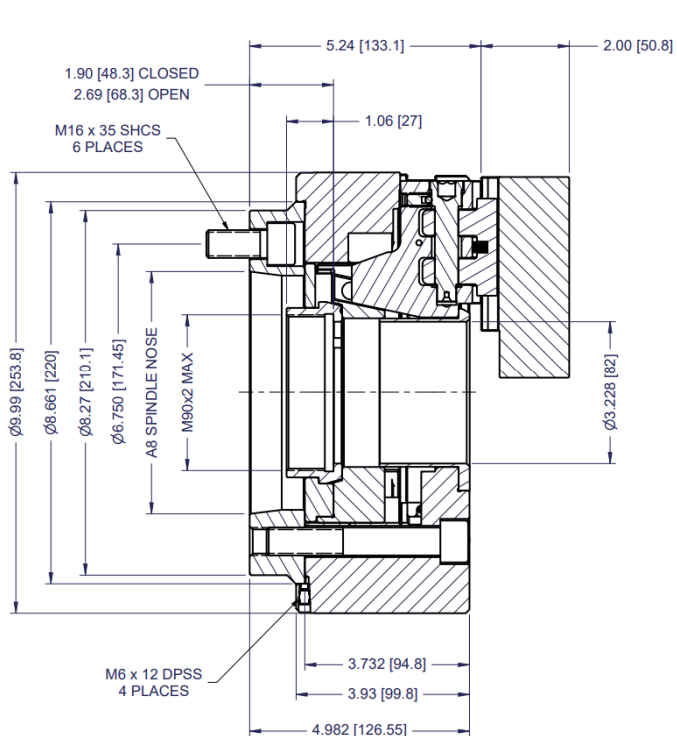

## KSF-08/QC Precision Change Chuck



### Features

- Patented QC Precision Change Jaw System
- 8.25" (210mm) chuck diameter
- 2.598" (66mm) through hole
- Precision fit master jaws to minimize jaw lift
- Hardened chuck body, actuators, and master jaws, for long term accuracy and performance

### Repeating Accuracy

- .0001" (0.0025mm) TIR

Chuck Model	KSF-08/QC
Jaw System	Precision Change
Number of Jaws	3
Repeating Accuracy <sup>1</sup>	0.0001" 0.0025mm
Through Hole Diameter	2.598" 66mm
Jaw Stroke (on diameter)	.299" 7.6mm
Actuator Stroke	.709" 18mm
Max Draw Tube Force	8,540 lbs 38 kN
Max Clamping Force	21,130 lbs 94 kN
Max Speed <sup>2</sup>	5,000 rpm
Chuck Weight <sup>3</sup>	52.0 lbs 23.6 kg
Moment of Inertia <sup>3</sup>	13.5 lb-ft <sup>2</sup> .57 kg-m <sup>2</sup>

1- Accuracy is the total indicator reading (radial and lateral runout) of a master gage measured 1.00" (25.4mm) from the top face of the standard top jaw at 1/2 max draw tube force.

2- With standard top jaws at max draw tube force.

3- With standard top jaws and A2-6 spindle mounting plate.

### Standard Accessories

- Blank draw tube adapter
- 1 set blank top jaws
- Chuck lubricant, and grease guns are sold separately.

### Threaded Draw Tube Adapters & Spindle Mounting Plates

- Threaded draw tube adapters are furnished on request
- A2-5, A2-6, A2-8 as well as other spindle mounting plates are available.

### KSF-08/QC Dimensions

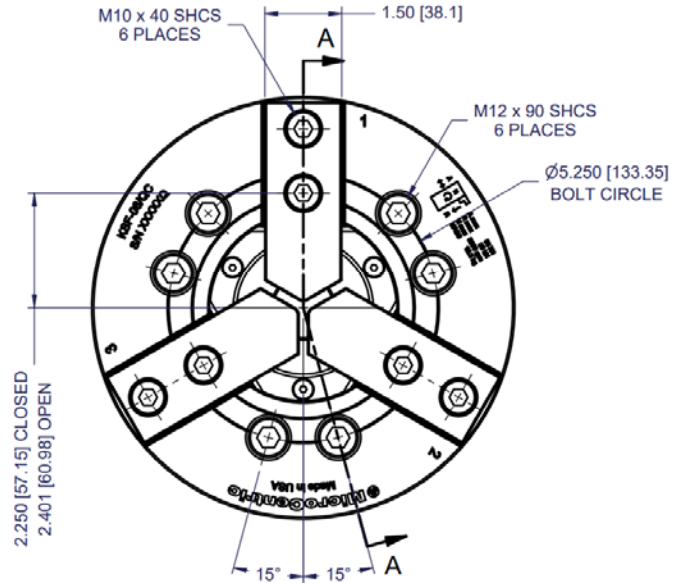
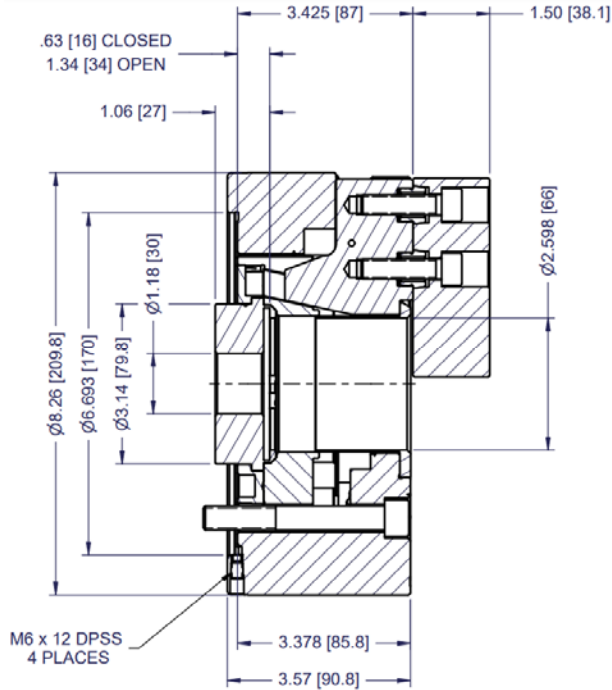

### KSF-08/QC/A6 Dimensions

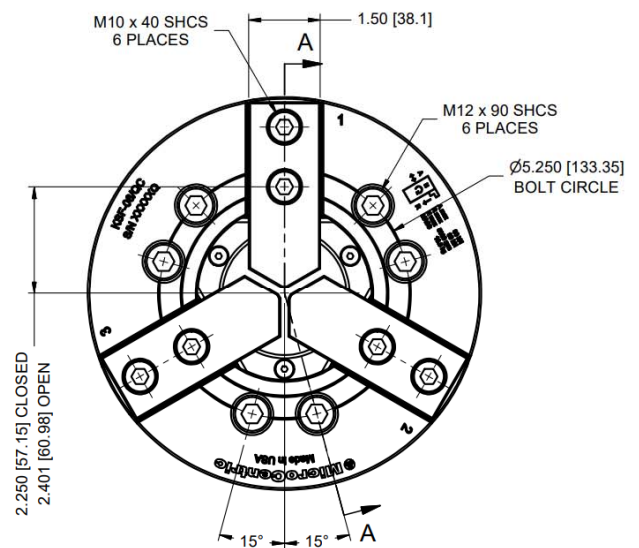
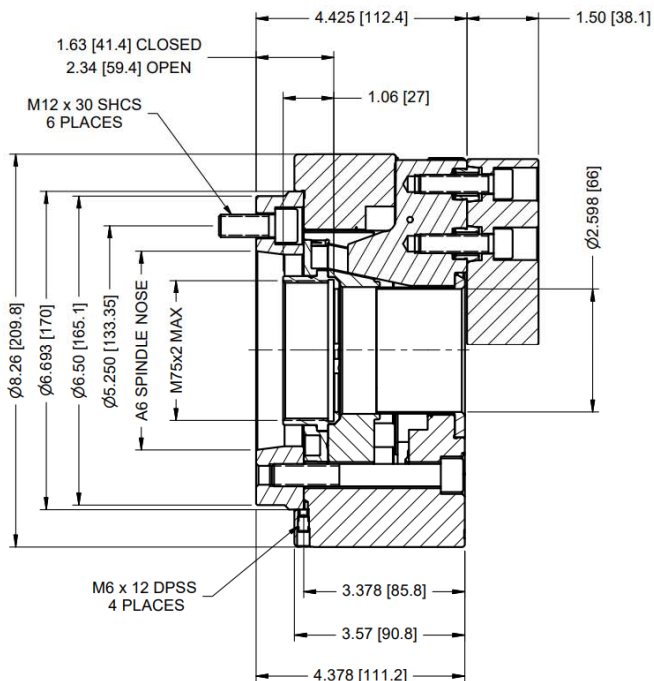

## KSF-10/QC Precision Change Chuck



### Features

- Patented QC Precision Change Jaw System
- 10.00" (254mm) chuck diameter
- 3.228" (82mm) through hole
- Precision fit master jaws to minimize jaw lift
- Hardened chuck body, actuators, and master jaws, for long term accuracy and performance

### Repeating Accuracy

- .0001" (0.0025mm) TIR

Chuck Model	KSF-10/RC
Jaw System	Rapid Change
Number of Jaws	3
Repeating Accuracy <sup>1</sup>	0.0001" 0.0025mm
Through Hole Diameter	3.228" 82mm
Jaw Stroke (on diameter)	.335" 8.5mm
Actuator Stroke	.787" 20mm
Max Draw Tube Force	11,240 lbs 50 kN
Max Clamping Force	26,970 lbs 120 kN
Max Speed <sup>2</sup>	4,500 rpm
Chuck Weight <sup>3</sup>	88.2 lbs 40.0 kg
Moment of Inertia <sup>3</sup>	31.1 lb-ft <sup>2</sup> 1.31 kg-m <sup>2</sup>

1- Accuracy is the total indicator reading (radial and lateral runout) of a master gage measured 1.00" (25.4mm) from the top face of the standard top jaw at 1/2 max draw tube force.

2- With standard top jaws at max draw tube force.

3- With standard top jaws and A2-8 spindle mounting plate.

### Standard Accessories

- Blank draw tube adapter
- 1 set blank top jaws
- Chuck lubricant, and grease guns are sold separately.

### Threaded Draw Tube Adapters & Spindle Mounting Plates

- Threaded draw tube adapters are furnished on request
- A2-6, A2-8, A2-11 as well as other spindle mounting plates are available.

## KSF-10/QC Dimensions

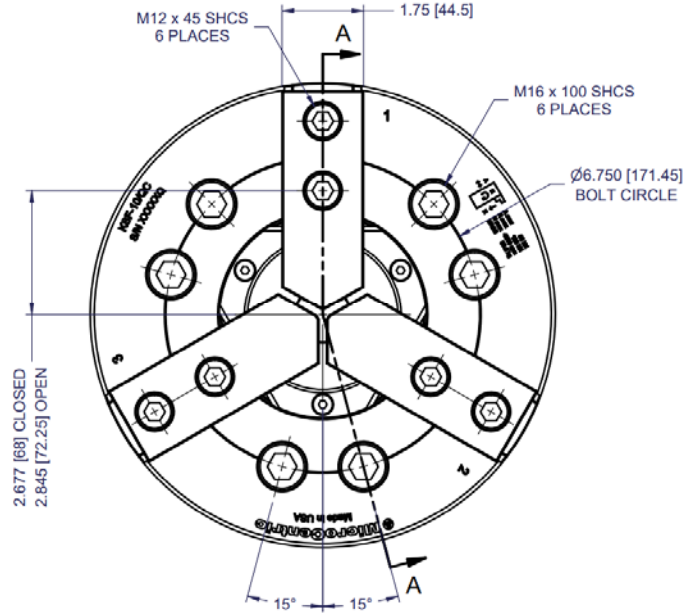
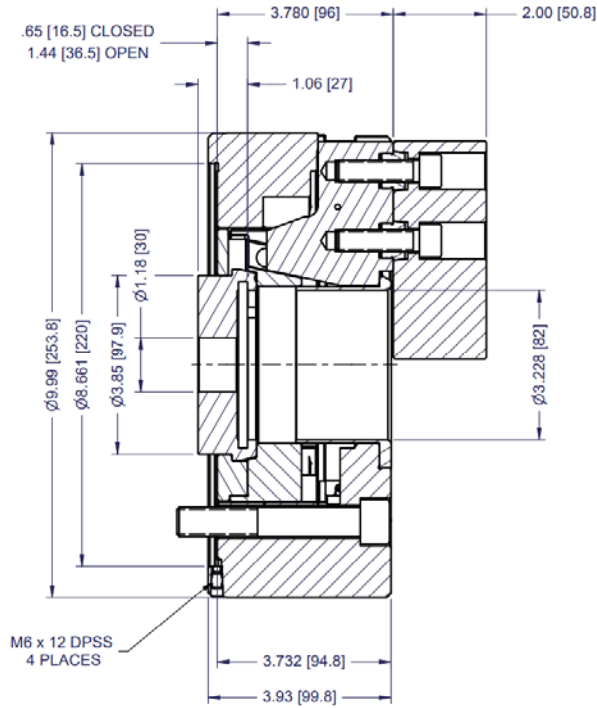

## KSF-10/QC/A8 Dimensions

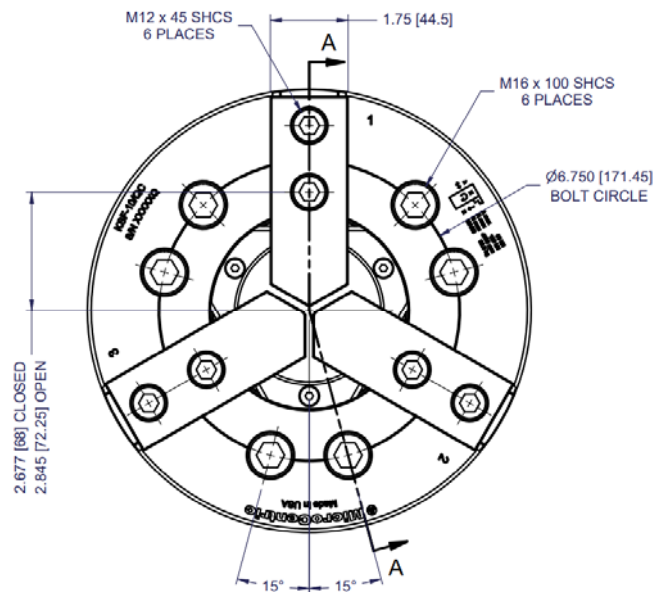
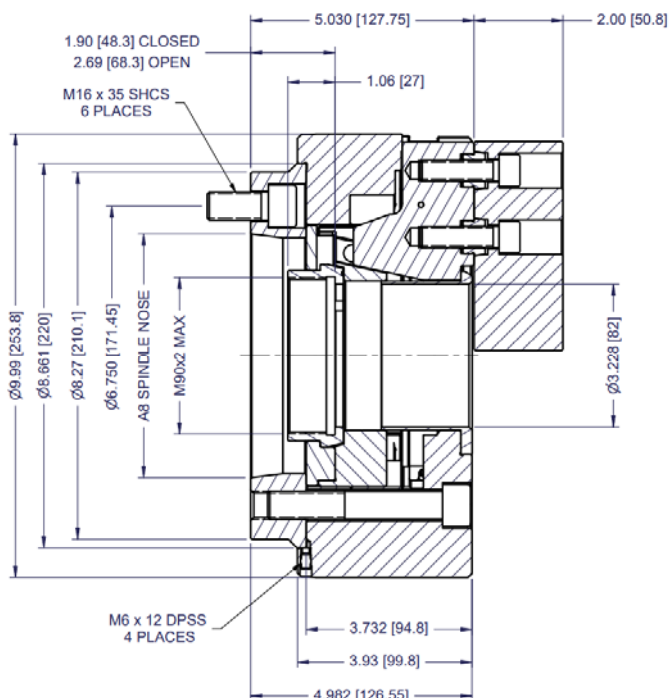

## RC Rapid Change Top Jaws

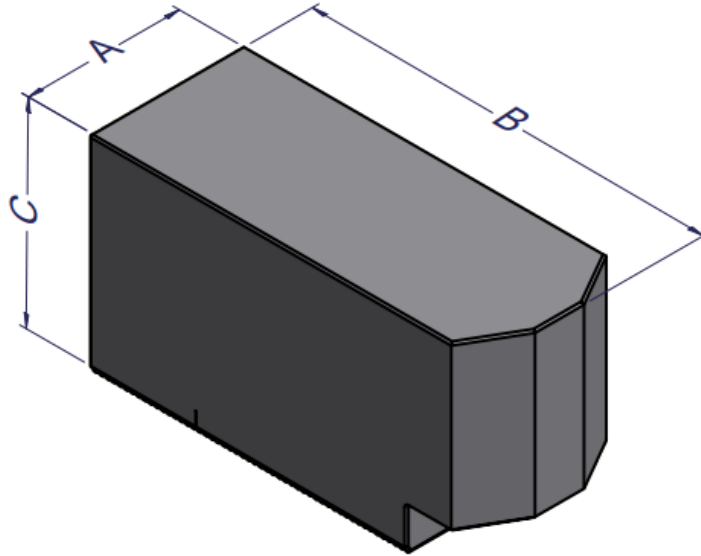

Chuck	Model	Material	A	B	C	Weight*
KSF-08	RK8-150S	1045	1.50"	3.80"	1.50"	2.0 lb
			38.1mm	96.5mm	38.1mm	0.9 kg
	RK8-200S	1045	1.50"	3.80"	2.00"	2.8 lb
			38.1mm	96.5mm	50.8mm	1.3 kg
	RK8-300S	1045	1.50"	3.80"	3.00"	4.4 lb
			38.1mm	96.5mm	76.2mm	2.0 kg
KSF-10	RK10-200S	1045	1.75"	4.57"	2.00"	3.9 lb
			44.5mm	116.1mm	50.8mm	1.8 kg
	RK10-300S	1045	1.75"	4.57"	3.00"	6.1 lb
			44.5mm	116.1mm	76.2mm	2.8 kg

## QC Precision Change Top Jaws

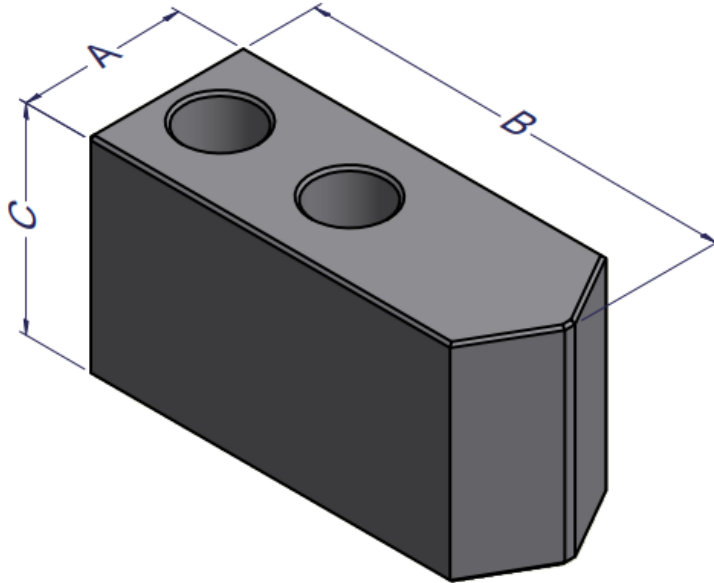

Chuck	Model	Material	A	B	C	Weight*
KSF-08	QK8-150S	A-2	1.50" 38.1mm	3.90" 99.1mm	1.50" 38.1mm	2.1 lb 1.0 kg
	QK8-200S	A-2	1.50" 38.1mm	3.90" 99.1mm	2.00" 50.8mm	2.8 lb 1.3 kg
	QK8-300S	A-2	1.50" 38.1mm	3.90" 99.1mm	3.00" 76.2mm	4.1 lb 1.9 kg
KSF-10	QK10-200S	A-2	1.75" 44.5mm	4.70" 119.4mm	2.00" 50.8mm	3.9 lb 1.8 kg
	QK10-300S	A-2	1.75" 44.5mm	4.70" 119.4mm	3.00" 76.2mm	6.9 lb 2.7 kg

Blank QC Top Jaws are made from A-2 tool steel. The tapered locating holes are precision jig bored for accurate location. QC jaws can be heat treated with minimal distortion to a hardness up to Rc 62. Special QC Top Jaws are quoted upon request.

QC jaw turning fixtures simulate the locating pattern of a QC chuck. They are used to rough machine Blank QC Top Jaws *off-line* to maximize a machine's production capacity. The clamping position of the jaw turning fixture is set in the middle of the chuck's stroke. Other positions are available upon request. See Page 16.

## RC Rapid Change Claw Top Jaws



Chuck	Model	Material	OD Clamp Range	ID Clamp Range	Weight
KSF-08	CLAW 1	4150	0.91-2.28"	8.86-10.47"	1.41 lb
			23-58mm	225-266mm	0.64 kg
	CLAW 2	4150	2.20-3.74"	7.36-8.98"	1.31 lb
			56-95mm	187-228mm	0.59 kg
CLAW 3	4150	3.62-5.16"	6.06-7.68"	1.23 lb	
		92-131mm	154-195mm	0.56 kg	
CLAW 4	4150	5.00-6.57"	4.69-6.26"	1.25 lb	
		127-167mm	119-159mm	0.57 kg	
KSF-10	CLAW 1	4150	0.91-2.76"	10.75-12.87"	2.21 lb
			23-70mm	273-327mm	1.00 kg
	CLAW 2	4150	2.68-4.69"	8.86-10.94"	2.04 lb
			68-119mm	225-278mm	0.93 kg
CLAW 3	4150	4.57-6.57"	7.13-9.21"	1.88 lb	
		116-167mm	181-234mm	0.85 kg	
CLAW 4	4150	6.42-8.50"	5.24-7.28"	1.81 lb	
		163-216mm	133-185mm	0.82 kg	

Rapid Change Claw Top Jaws are made from 4150 hardened Rc. 52-56.



## *RC Rapid Change Step Top Jaws*

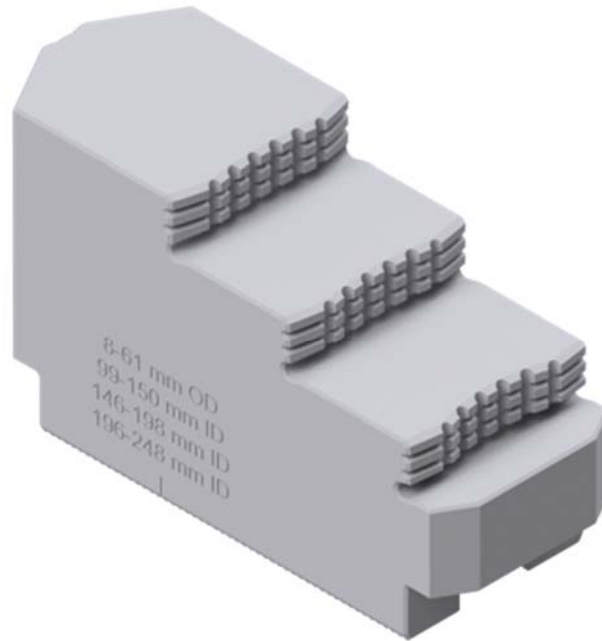

Chuck	Model	Material	OD Clamp Range	ID Clamp Range	Weight
KSF-08	STEP JAW	4150	0.32-7.28"	3.90-9.76"	2.60 lb
			8-185mm	99-248mm	1.18 kg
KSF-10	STEP JAW	4150	0.47-9.45"	3.78-10.59"	3.35 lb
			12-240mm	96-269mm	1.52 kg

Rapid Change Step Top Jaws are made from 4150 hardened Rc. 52-56.

## Chuck Lubricant



<i>Model</i>	<i>Quantity</i>	<i>Manufacturer</i>
<b>ALTEMP Q NB 50/080</b>	80 gram tube	Kluber
<b>ALTEMP Q NB 50/600</b>	600 gram cartridge	Kluber
<b>ALTEMP Q NB 50/750</b>	750 gram cartridge	Kluber

Kluber ALTEMP Q NB 50 is the recommended lubricant for KSF chucks. ALTEMP Q NB 50 is a white lubricating paste containing a mineral base oil, a barium complex soap and inorganic solid lubricants. This lubricant has been found to improve the sliding characteristics of moving chuck components and enabling constant clamping force. It prevents stick-slip and protects against fretting and tribo-corrosion in frictional or positive connections. ALTEMP Q NB 50 is resistant to oils and water soluble cutting fluids.

## Grease Guns



<i>Model</i>	<i>Capacity</i>	<i>Chuck Model</i>
<b>P-1</b>	14 oz (414 ml)	KSF Chucks

The P-1 is a lever operated cartridge style grease gun with a tip suited to the fittings on KSF chuck models

## Loading Rings



<i>Chuck Size</i>	<i>Model</i>	<i>Application</i>
<b>KSF-08</b>	CR-K8	OD Clamping
	LR-K8	ID Clamping
<b>KSF-10</b>	CR-K10	OD Clamping
	LR-K10	ID Clamping

Loading rings are used to set the chuck in a clamping position for machining top jaws. CR loading rings are a cam design which provide easy adjustment of the loading position for OD clamping. LR loading rings are used for ID clamping jaws.

# Spindle Data Sheet



Chuck Model		Date	
Serial No.		Ref. No.	

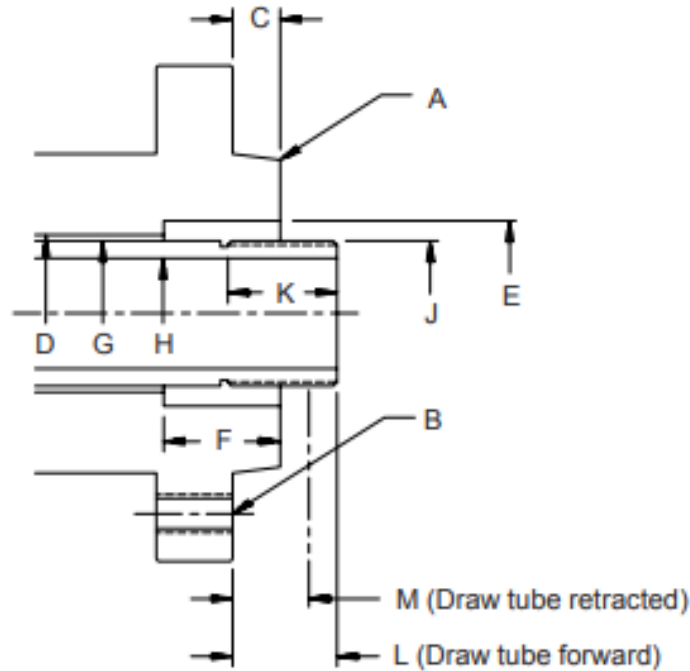

Machine Make	
Machine Model	
Machine Serial No.	
A* taper size	
B mounting thread	
C length of pilot	
D through hole diameter	
E ID counterbore or taper (if any)	
F depth of counterbore (if any)	
G OD of draw tube	
H ID of draw tube	
J thread (RH or LH / ID or OD)	
K length of thread	
L** forward position	
M retracted position	

\* For machines with a straight spindle pilot a detail drawing of the spindle must be submitted

\*\* Positive (+) indicates draw tube is in front of the spindle face (as shown)  
 Negative (-) indicates draw tube is behind the spindle face



Microcentric Corporation

25 South Terminal Drive, Plainview, NY 11803-2303 • USA

Tel: 516-349-7220 • Fax: 516-349-9354 • e-mail: [sales@MicroCentric.com](mailto:sales@MicroCentric.com)

**1-800-573-1139 • [www.microcentric.com](http://www.microcentric.com)**

Microcentric GmbH

Ringstrasse 134 • 70839 Gerlingen • Germany

Tel: 49-71156-17819-00 • e-mail: [info@MicroCentric.de](mailto:info@MicroCentric.de)

**[www.microcentric.de](http://www.microcentric.de)**