









Special tools

Drilling	<p>PCD tipped single flute/twin flute gundrills and form boring tools are also available.</p> 		<p>Step and form boring tools with indexable inserts.</p> 		<p>Type 158-00 Solid carbide twist drill (high performance twist drill) 4 margins / coolant fed</p> <p>diameter range: 3.000 - 14.000 mm</p> 	<p>Type 158-01 Solid carbide twist drill 2 margins / coolant fed (available on request)</p> <p>diameter range 3.000 - 14.000 mm</p> 
----------	--	--	--	--	---	---

Milling	<p>Type B200 Solid carbide drill DIN 1897 3-fluted 30° helix 140° drill point</p> <p>Ø 3.000 - 20.000 mm</p> 	<p>Type B300 Tap size end mill solid carbide DIN 8378 3-fluted 30° helix 90° countersink</p> <p>Ø 2.500 - 10.200 mm</p> 	<p>Type F005-01 Insert pocket end mill solid carbide 3-fluted</p> <p>Ø 1.800 - 25.000 mm</p> 	<p>Type F244...F251 Ball nose end mill solid carbide DIN 6527 + botek standard 2-fluted</p> <p>Ø 3.000 - 20.000 mm (25.000 mm)</p> 	<p>Type F341...F347 Ball nose end mill solid carbide DIN 6527 + botek standard 3-fluted 30° helix</p> <p>Ø 3.000 - 20.000 mm</p> 	<p>Type F440...F445 Ball nose end mill solid carbide DIN 6527 + botek standard 4-fluted</p> <p>Ø 3.000 - 20.000 mm (25.000 mm)</p> 	<p>Non standards also available. Please contact your botek representative.</p>
---------	---	--	---	---	---	---	---

Reaming	<p>Type 140 4 cutting edge counterboring tool with solid carbide tip</p> <p>diameter range: 6.000 - 40.000 mm</p> 	<p>Type 160 6 cutting edges counterboring tool with solid carbide tip</p> <p>diameter range: 6.000 - 40.000 mm</p> 	<p>Special tools on request.</p>
---------	--	---	---



Regrinding (single flute gundrills)

<p>Type PS Sharpening fixture single flute gundrills can be reground on any good tool grinding machine. drill-range: Ø 0.500 - 6.000 mm</p> 	<p>Type ZS Sharpening fixture single flute gundrills can be reground on any good tool grinding machine. drill-range: Ø 2.000 - 50.000 mm</p> 	<p>MS 01 Bench top grinding machine suitable for our sharpening fixtures.</p> 	<p>MS 12-2 Multi-station grinding machine for highly efficient grinding of large batches of tools with the same point geometry. The machine is suitable for tool diameters from 1.850 mm to 12.000 mm and tool lengths up to approx. 1000 mm.</p> 	<p>MS 12-3 Multi-station grinding machine for highly efficient grinding of large batches of tools with the same point geometry. The machine is suitable for tool diameters from 1.850 mm to 12.000 mm and tool lengths up to approx. 1000 mm.</p> 	<p>Additional accessories (grinding wheels, tool holders etc.) are also available.</p>
---	---	--	--	--	---

Axial-Pulsator

Coolant pressure gauging-kit

Drill Head Setting Gauge

<p>Axial-Pulsator The botek Axial-Pulsator has been developed to maximize the feed rate of straight fluted deep hole drilling tools when drilling steel and long chipping materials.</p> <p>botek's Axial-Pulsator achieves equal hole making quality (straightness, run out, concentricity and surface finish) as standard deep hole drilling tools with economic performance.</p> 	<p>Coolant pressure gauging-kit Coolant pressure gauging-kit for machining centres on deep hole drilling machines.</p> 	<p>Drill Head Setting Gauge Process reliable diameter setting of drill heads.</p> 
---	---	---

Express production line/Stock program

Express production line

Product range:

- Type 110 Single flute gundrills with brazed carbide tip
- Type 120 Twin fluted drills with brazed carbide tip
- Type 113 Single flute gundrills in solid carbide design
- Type 01 Single flute gundrills with indexable inserts and guide pads

Contact:

Andreas Lehmann (Lehmann@botek.de; F: +49 7123 3808-192)

Stock program:

- Type 110 Single flute gundrills with brazed carbide tip
- Type 113 Single flute gundrills in solid carbide design
- Type 113-HP Single flute gundrills in solid carbide design
- Type 01 Single flute gundrills with indexable inserts and guide pads

More information regarding our stock program please see our new homepage, www.botek.de.

Service

Customer testing in our research and development department:

- tool development specifically tailored to suit your application
- supportive when introducing the latest technology
- solving processing problems

Process layout: You submit us your drilling application and we will develop the whole process from engineering to finding the perfect tooling solution.

Process optimization: Our team of Application Engineers analyse and improve your process in your facility and coordinate all technical details.

Reduced manufacturing costs by:

- optimised cutting values
- improved tool life
- shortened auxiliary process time
- maximized process capacity is our goal.

The botek trial department assists you in all stages of the process with:

- Feasibility tests
- Optimization
- Instruction and training for your technicians

Regrinding:

botek offers prompt and cost effective in house regrinding service.

Coating:

botek offers prompt and cost effective in house coating service.

You can download our catalogs [HERE](#)

- Please see our application notes
- Our General Standard Terms and Conditions, which we assume as known, apply.
- We reserve the right to make modifications in the interests of technical improvement. Such modifications cannot, in principle, be accepted as justifiable grounds for complaint.
- Subject to change. The manufacturer accepts no responsibility for misprints and other errors.

botek®

DEEP HOLE DRILLING SYSTEMS
SOLID CARBIDE TOOLS

botekUSA

200 N Garden Avenue
Roselle, IL 60172

Phone (630) 893-5300

Fax (630) 893-5400

E-Mail Info@botekUSA.com

www.botekUSA.com

250 000 002/32-2018

botek®

DEEP HOLE DRILLING SYSTEMS
SOLID CARBIDE TOOLS

Product line botek

New:
Type 03









Single flute gundrills



Twin fluted drills

System BTA

System Ejector

<p>Type 113 Solid carbide gundrill kidney-shaped coolant channel</p> <p>diameter range: 0.500-12.000 mm</p> 	<p>Type 113-01 Solid carbide stepped drill kidney-shaped coolant channel</p> <p>diameter range: 1.500-... mm</p> 	<p>Type 113-HP Solid carbide gundrill New: High performance tool design alternative to carbide twist drills</p> <p>diameter range: 0.700 - 12.000 mm</p> 	<p>Type 113-HP-M Solid carbide gundrill New: High performance tool design for the usage with MQL</p> <p>diameter range: 2.000 - 12.000 mm</p> 	<p>Type 110 Single flute gundrill with brazed solid carbide tip kidney-shaped coolant channel</p> <p>1 coolant hole diameter range 1.850 - 7.059 mm 2 coolant holes diameter range 7.060 - 51.200 mm</p> 	<p>Type 111 Single flute gundrill drill head made of a steel body with inserted carbide cutting blade and bearing pads</p> <p>1 coolant hole diameter range 5.800 - 40.009 mm 2 coolant holes diameter range 40.010 - 60.009 mm</p> 	<p>Type 112 Single flute stepped gundrill with solid carbide tip (to produce precise stepped holes in one operation) Kidney-shaped coolant channel or 2 coolant holes depending on tool diameter</p> <p>diameter range: 2.000 - 51.200 mm</p> 
--	---	---	--	---	--	---

Type 113 / 110 / 112 also available cutting edge with PCD (from Ø 4.0 mm)

<p>Type 120 Twin fluted drills with solid carbide head, larger dia. on request</p> <p>diameter range: 6.000 - 26.500 mm</p> 	<p>Type 122 Twin fluted stepped solid drilling tool with solid carbide head</p> <p>diameter range: 4.510 - 26.500 mm</p> 	<p>Type 123 Solid carbide 2-fluted drill coolant fed double margin</p> <p>diameter range: 2.800 - 32.000 mm</p> 
--	---	--



<p>Type 17 Solid drill head regrindable, brazed carbide blade and guide pads, head to be brazed onto drill tube</p> <p>drilling range: 7.76 - 15.50 mm</p> 	<p>Type 18 Solid drill head regrindable, brazed carbide blade and guide pads, 1-start connection thread external</p> <p>drilling range: 12.21 - 15.50 mm</p> 	<p>Type 20 Solid drill head regrindable, brazed carbide blade and guide pads</p> <p>drilling range: 14.51 - 36.99 mm</p> 	<p>Type 11 Solid drill head with indexable inserts and guide pads, setting of drill diameter by stop plate</p> <p>drilling range: 14.55 - 36.99 mm</p> 	<p>Type 70B Solid drill head with indexable inserts and guide pads, diameter will be manufactured as per order</p> <p>drilling range: 25.00 - 64.99 mm</p> 
---	---	---	---	---

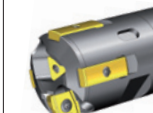

1-start connection thread internal

<p>Type 12 Solid drill head with indexable inserts and guide pads, setting of drill diameter by stop plate</p> <p>drilling range: 28.50 - 74.99 mm</p> 

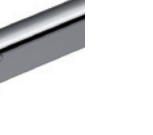
<p>Type 15 Solid drill head brazed type, disposable</p> <p>drilling range: 18.40 - 65.00 mm</p> 	<p>Type 60 Solid drill head with indexable inserts and guide pads, setting of drill diameter by stop plate</p> <p>drilling range: 18.40 - 36.20 mm</p> 	<p>Type 70E Solid drill head with indexable inserts and guide pads, diameter will be manufactured as per order</p> <p>drilling range: 25.00 - 64.99 mm</p> 
--	---	---

4-start connection thread external

<p>Type 01 Deep hole drilling tool with indexable inserts and guide pads, setting of drill diameter by stop plate</p> <p>diameter range: 12.000 - 43.99 mm</p> 	<p>Type 07 Deep hole drilling tool with indexable inserts and guide pads, diameter will be manufactured as per order</p> <p>diameter range: 25.00 - 50.99 mm</p> 	<p>Type 02 Deep hole drilling tool with indexable inserts and guide pads, setting of drill diameter by stop plate, larger dia. on request</p> <p>diameter range: 37.00 - 100.00 mm</p> 	<p>Type 07A Deep hole drilling tool with indexable inserts and guide pads, diameter will be manufactured as per order</p> <p>drilling range: 51.00 - 113.99 mm</p> 
---	---	---	---

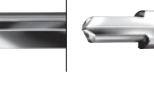
<p>Type 03 Twin fluted drills with indexable inserts and guide pads</p> <p>diameter range-Ø 10.00 - 22.49 mm</p> 	<p>Type 123-01 Solid carbide 2-fluted drill for taps, coolant fed, step angle 90°</p> <p>diameter range-Ø 2.800 - 32.000 mm</p> 	<p>Type 123-02 Solid carbide 2-fluted step drill for taps, coolant fed, step angle 180°</p> <p>diameter range-Ø 2.800 - 32.000 mm</p> 
---	--	--

Type 120/ 123 also available cutting edge with PCD





<p>Type 14 Solid drill head brazed type, disposable</p> <p>drilling range: 15.61 - 65.00 mm</p> 	<p>Type 61 Solid drill head with indexable inserts and guide pads, setting of drill diameter by stop plate</p> <p>drilling range: 15.65 - 36.20 mm</p> 	<p>Type 70A Solid drill head with indexable inserts and guide pads, diameter will be manufactured as per order</p> <p>drilling range: 25.00 - 64.99 mm</p> 	<p>Type 64 Solid drill head with indexable inserts and guide pads, setting of drill diameter by stop plate</p> <p>drilling range: 28.71 - 74.99 mm</p> 
--	---	---	---



4-start connection thread external

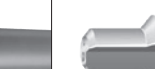

<p>Type 43B/A/F Solid drill head with indexable inserts and guide pads, setting of drill diameter by stop plate</p> <p>drilling range: 60.00 - 368.99 mm</p> 

<p>Type 62 Solid drill head with indexable inserts and guide pads, setting of drill diameter by stop plate</p> <p>drilling range: 28.71 - 74.99 mm</p> 	<p>Type 43E Solid drill head with indexable inserts and guide pads, setting of drill diameter by stop plate</p> <p>drilling range: 60.00 - 188.99 mm</p> 
---	---



4-start connection thread external

<p>Type 113-02 Single flute counterboring tool solid carbide</p> <p>diameter range: 0.500 - 10.000 mm</p> 	<p>Type 115 Single flute counterboring tool with solid carbide tip, chips forward (round tube)</p> <p>diameter range: 2.000 - 51.200 mm</p> 	<p>Type 115-01 Single flute stepped counterboring tool with solid carbide tip</p> <p>diameter range: 2.000 - 51.200 mm</p> 	<p>Type 115-03 Single flute counterboring tool with guiding pilot with solid carbide tip</p> <p>diameter range: 4.000 - 12.000 mm</p> 	<p>Type 115-04 Single flute counterboring tool with guiding pilot steel body with inserted carbide cutting blade and bearing pads</p> <p>diameter range: 12.001 - 60.006 mm</p> 
--	--	---	--	--

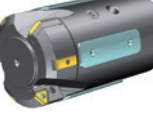
<p>Type 125 Twin fluted counterboring tool with solid carbide head</p> <p>diameter range: 4.000 - 40.000 mm</p> 	<p>Type 125-03 Twin fluted counterboring tool with guiding pilot with solid carbide tip and steel shank</p> <p>diameter range: 6.000 - 40.000 mm</p> 
--	---

<p>Type 13B/A Counterboring head 1-start or 4-start connection thread, without add. fibre guide pads for boring depth up to 30 x dia.</p> <p>drilling range Type 13B: 28.50 - 74.99 mm drilling range Type 13A: 28.71 - 74.99 mm</p> 	<p>Type 34/Type 54 Counterboring head 1-start or 4-start connection thread</p> <p>drilling range Type 34: 44.00 - 353.99 mm drilling range Type 54: 47.00 - 353.99 mm</p> 	<p>Type 35B/A/F Counterboring head 1-start or 4-start connection thread or flange mounting, large adjustment range</p> <p>drilling range: 61.00 - 498.99 mm</p> 	<p>Type 36/Type 56 Counterboring head multi-cutter 1-start or 4-start connection thread with indexable inserts and guide pads</p> <p>drilling range: 60.00 - 250.00 mm</p> 	<p>Type 33B/A/F Counterboring head multi-cutter 1-start or 4-start connection thread or flange mounting, large adjustment range</p> <p>drilling range: 159.00 - 498.99 mm</p> 
---	--	--	---	--

with add. fibre guide pads for boring depth up to 100 x dia.

<p>Type 38 Pull boring head 1-start connection thread internal</p> <p>drilling range: 20.00 - 222.99 mm</p> 	<p>Type 58 Pull boring head 4-start connection thread external</p> <p>drilling range: 20.00 - 222.99 mm</p> 
--	--



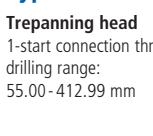
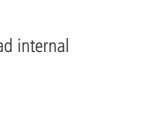

<p>Type 13E Counterboring head 4-start connection thread external, setting of drill diameter by stop plate</p> <p>drilling range: 28.71 - 74.99 mm</p> 	<p>Type 35E Counterboring head 4-start connection thread external, large adjustment range</p> <p>drilling range: 61.00 - 198.99 mm</p> 
---	---

without add. fibre guide pads for boring depth up to 30 x dia.

<p>Type 114 Trepanning gundrill carbide tip for producing annular drill holes diameter range: 11.000 - 50.000 mm</p> 	<p>Type 08 Trepanning tool diameter range 25.000 - 100.000 mm</p> 	<p>Type 09 Core Cutter diameter range 30.000 - 70.000 mm</p> 
---	--	---

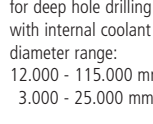

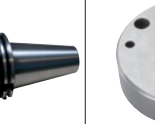

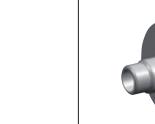
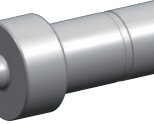
<p>Type 28 Trepanning head 1-start connection thread internal drilling range: 55.00 - 412.99 mm</p> 	<p>Type 48 Trepanning head 4-start connection thread external drilling range: 55.00 - 197.99 mm flange mounting drilling range: 198.00 - 412.99 mm</p> 
--	---

<p>Core cutter for cores up to max. Ø 60.00 mm</p> 

<p>Rotating coolant connector for deep hole drilling tools with internal coolant supply diameter range: 12.000 - 115.000 mm 3.000 - 25.000 mm</p> 	<p>Clamping cone 170-02</p> 	<p>Drill bush holder 170-03</p> 	<p>Drill bushings 170-04 according to DIN 179 extended, made of steel, hardened throughout</p> 	<p>Whippguide bushings with and without hole or formed type</p> 	<p>Sealing disc 170-07</p> 
--	--	--	---	--	---

<p>Type 25 Drill tube with 1-start connection thread external</p> 	<p>Type 45 Drill tube with 4-start connection thread internal</p> 	<p>Drill tube drivers (split style)</p> 	<p>Drill tube drivers (collet style)</p> 	<p>Vibration dampers</p> 
--	--	--	---	---



<p>Type 55 Drill tube (outer tube) with 4-start connection thread internal</p> 	<p>Type 55 Inner tube for all types of coolant connectors</p> 
---	--

<p>Type 153-02 Solid carbide pilot drill not coolant fed/point angle 140° 3 x D (drill flute length) diameter range: 1.000 - 26.000 mm</p> 	<p>Type 153-03 Solid carbide pilot drill coolant fed/point angle 140° 5 x D (drill flute length) diameter range: 3.000 - 26.000 mm</p> 	<p>Type 158-07 Solid carbide pilot drill not coolant fed/point angle 160° 3 x D (drill flute length) diameter range: 3.000 - 14.000 mm</p> 	<p>Type 158-08 Solid carbide pilot drill coolant fed/point angle 160° 5 x D (drill flute length) diameter range: 3.000 - 14.000 mm</p> 
---	---	---	---

Single flute and twin fluted gundrills are highly suitable for drilling on modern CNC machining centres.

<p>Pressure heads (BOZA) for rotating and non-rotating workpieces with clamping cones or face sealing</p> 	<p>Drill tube adaptor</p> 
--	--

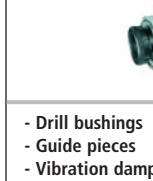
Tools for drilling system BTA are not recommended for use on machining centres.

<p>Rotating connector</p>  <ul style="list-style-type: none"> - Drill bushings - Guide pieces - Drill head setting gauges - Vibration dampers 	<p>Non-rotating connector</p>  <ul style="list-style-type: none"> - Drill head setting gauges - Grinding arbors
---	---

Tools for drilling system Ejector are highly suitable for drilling on modern CNC machining centres.