

ARCH[®]
Cutting Tools

INSERTS

THE COMPLETE TOOL MAKING AUTHORITY[®]

INSERTS

Our inserts are for a wide array of tools throughout our indexable milling, drilling, boring, and turning offering



Insert Speeds & Feeds

Material		TURNING		MILLING		DRILLING	
		SFM	Inch/ Rev	SFM	Inch/ Rev	SFM	Inch/ Rev
P	Mild Steel	490-1200	.004-.031	250-800	.003-.015	225-650	.0022-.006
	Annealed Alloy Steel	490-980		200-725		200-650	
	Hardened Alloy Steel	180-500		200-600		100-300	
	Cast Steel	180-650		200-600		150-550	
M	Stainless Steel	280-810	.004-.015	200-600	.003-.015	250-430	.002-.006
K	Low Cast Iron	590-1240	.004-.024	325-600	.004-.016	300-600	.0025-.009
	High Cast Iron	360-700		325-600		300-600	
	Cast Iron (CBN INSERTS)	400-600	.002-.020				
N	Alum. Alloy Un-heat Treated	850-1980	.004-.018	860-1800	.007-.018	600-1100	.0038-.011
	Alum. Alloy Heat Treated	550-1650		575-1230		315-790	
	Cast Alum. & Copper Alloy	360-950		280-930		250-760	
H	Hardened Material (CBN INSERTS)	450-950	.002-.011				
S	Heat Resistant Steels	100-300	.002-.006	100-300	.0024-.008	60-150	.0028-.008

Chipbreaker Designation

ISO	FINISHING	MEDIUM	ROUGHING
P	CX2, LX6, SP1, SP2, SX1, ZX3 CM1, CM3, CX2, LX6, ZM1	CX1, LX3, ZP1 CM1, CM2, LX3	CP2, LX2 LX2
M			
K	ZX3	ZK1, ZK2 CS1	
N	SX1, ZN1	CN1, LX2, LX3	
S	ZX3	ZK1, ZK2 CS1	

○ Good
◐ Better
● Best

*HIGH PERFORMANCE GRADES

Grade	Description	Steel	Stainless Steel	Cast Iron	Ferrite Materials	Heat-Resistant	Steel Hardened Metal
		P	M	K	N	S	H
UD51	General purpose TiN (CVD) coated steel grade - used for roughing and semi-finishing of carbon alloy and stainless steel.	●	○	○		◐	
UD52	Tough general purpose steel grade with multi-layer titanium aluminum nitride coating for alloy steel, aluminum alloys, austenitic stainless and carbon steels, copper alloys and exotic alloys.	●	○			●	
HP230*	Productive steel turning grade under stable conditions.	●	○	◐			
HP250*	Universal steel turning grade-The best in efficiency and productivity.	●	○	◐			
UD21	Multi-layer titanium aluminum nitride grade. Excellent for machining cast iron.		◐	●			
HM240*	Stainless steel turning grade. Finishing to light roughing.	○	●		○		
HM250*	Turning grade for wide application in the stainless steel range. Finishing to roughing.	◐	●			○	
HS220*	Excellent for heat resistance and titanium alloys		○			●	
UD2	Uncoated - Used to cut cast iron, aluminum, non-ferrous alloys, non-metals and most high temp alloys. Provides excellent wear resistance.			○	◐		
HN432*	Ideal grade for aluminum. Low tendency for adhesion.			◐	●		
UD22	TiN coated insert. Suitable for semi-finishing and finishing of high temp alloys. Intended for cast iron machining.			●		◐	
UD32	TiAlN coated insert. Used in high speed medium load applications of stainless steel and finishing to semi-finishing of high temperature alloys.	◐	●	○	○	●	
HK036*	Stability in a wide range of applications with long tool life. First choice for turning cast iron.			●			
UD5C	Uncoated cermet grade for semi-finishing and finishing applications at medium to high cutting speeds on carbon and alloyed steels. Also used on stainless. Normally used without coolant.		○	○			
UD5CT	TiAlN coated cermet grade performs extremely well for semi-finish and finish applications in alloyed steels, stainless and high carbon steels.	●	◐	◐			
UD1	Uncoated – Designed with a polished surface and large rake angle, Intended for machining aluminum and other non-ferrous alloys. Also works well for semi machining on cast iron.		◐		●		
HP470*	Suitable for demanding steel milling applications, interrupted cut.	●	◐				
HM470*	Stainless steel milling grade. PVD, TiAlN coating.	◐	●				
HS470*	First choice for milling heat-resistant alloys.		○			●	
HS480*	Extremely heat-resistant tough grade for milling titanium.					●	
HK430*	Milling grade for cast iron.			●			
HP600*	Super tough substrate with PVD coating. Excellent for drilling steel and stainless steel.	●	◐	○	○	○	
HK356*	Stable cutting performance for drilling cast iron. Suitable for aluminum. Recommended for mild structural steel, difficult chip controlled steel.	◐	●	●	◐	◐	
HN300*	Drilling Grade for Aluminum				●		
UD2CBN	A Polycrystalline Cubic Boron Nitride (PCBN) Insert for cast iron, gray cast iron, chilled cast, and powder metal with long tool life. Coolant not recommended for use.			●			◐
UD5CBN	A Polycrystalline Cubic Boron Nitride (PCBN) Insert for precision finishing of hardened steels 50-65 rockwell. Coolant not recommended for use.			◐			●
UD2PCD	Polycrystalline Diamond with Carbide Reinforced Diamond, Sharpness and Low Cutting Pressure allowing tight tolerances. Finishing of all non-ferrous metals and non-metals.				●		
UD25	Uncoated - Used to cut aluminum, brass, copper, nickel base alloys, titanium and non-ferrous materials.			○	○		
UD204	A PVD TiAlN coated fine grain substrate. Excellent for light to medium feeds on cast iron and semi-finishing to finishing of high temperature alloys. Excellent for high SFM.	◐		●		◐	
UD404	A PVD TiAlN coated tough general purpose grade. Well suited for milling alloy steels, stainless steel, high temperature alloy steels and hardened steels up to 60 Rc.	●	●	◐		●	
UD602	A CVD coating of Ti A12O3 & TiN on a tough substrate. It is suitable for light to heavy milling of alloy steel and non alloy steel, even under unfavorable condition.	◐	◐			◐	



ZX3



CDGW Flat Top



CDHB Flat Top

PRODUCT #	DESIGNATION	Grade															
		HP230	HP250	HM240	HM250	HS220	HN432	HK036	UD51	UD52	UD21	UD2	UD22	UD32	UD5C	UD5CT	UD1
913-000-133	CDGT 1.510.5-ZX3								•								
913-000-134										•							
913-000-132											•						
913-000-131												•					
913-000-135													•				
913-000-136														•		•	
913-000-139	CDGT 1.511-ZX3								•								
913-000-140										•							
913-000-138											•						
913-000-137												•					
913-000-141															•		
913-000-142															•		
913-000-145	CDGW 1.510								•								
913-000-146										•							
913-000-144											•						
913-000-143												•					
913-000-147													•				
913-000-148														•		•	
913-000-151	CDGW 1.510.5								•								
913-000-152										•							
913-000-150											•						
913-000-149												•					
913-000-153															•		
913-000-154															•		
913-000-157	CDGW 1.511								•								
913-000-158										•							
913-000-156											•						
913-000-155												•					
913-000-159															•		•
913-000-160															•		
913-000-163	CDHB 1.20.60								•								
913-000-164										•							
913-000-162											•						
913-000-161												•					
913-000-165															•		
913-000-166															•		
913-000-169	CDHB 1.20.60.5								•								
913-000-170										•							
913-000-168											•						
913-000-167												•					
913-000-171															•		
913-000-172															•		

PACKAGE SIZE OF 10



CM1



CN1



CX1



CX2



ZM1

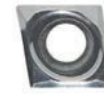

ZN1



ZX3

PRODUCT #	DESIGNATION	Grade															
		HP230	HP250	HM240	HM250	HS220	HN432	HK036	UD51	UD52	UD21	UD2	UD22	UD32	UD5C	UD5CT	UD1
914-000-001	CCGT 21.50-CM1			•													
914-000-004	CCGT 32.50.5-CM1			•													
914-000-005	CCGT 32.50-CM1			•													
914-000-002	CCGT 21.50-CN1						•										
914-000-003	CCGT 21.51-CN1						•										
914-000-006	CCGT 32.51-CN1						•										
914-000-007	CCGT 32.52-CN1						•										
914-000-010		•															
914-000-009					•												
914-000-011	CCMT 21.51-CX1		•														
914-000-008								•									
914-000-013			•														
914-000-012	CCMT 21.52-CX1				•												
914-000-018		•															
914-000-019			•														
914-000-017	CCMT 32.51-CX1				•												
914-000-016								•									
914-000-022		•															
914-000-023			•														
914-000-021	CCMT 32.52-CX1				•												
914-000-020								•									
914-000-026			•														
914-000-025	CCMT 431-CX1				•												
914-000-024								•									
914-000-028			•														
914-000-029	CCMT 432-CX1				•												
914-000-027								•									
914-000-015			•														
914-000-014	CCMT 32.50.5-CX2				•												
913-000-076	CCMT 21.51-ZM1												•				
913-000-083	CCMT 32.50.5-ZM1												•				
913-000-087	CCMT 32.51-ZM1												•				
913-000-091	CCMT 32.52-ZM1												•				
913-000-095	CCMT 431-ZM1												•				
913-000-099	CCMT 432-ZM1												•				
913-000-072	CCGX 21.50.5-ZN1																x
913-000-073	CCGX 21.51-ZN1																x
913-000-074	CCGX 32.51-ZN1																x
913-000-075	CCGX 32.52-ZN1																x
913-000-078								•									
913-000-079	CCMT 21.51-ZX3								•								
913-000-077										•							
913-000-081								•									
913-000-082	CCMT 21.52-ZX3								•								
913-000-080										•							
913-000-085								•									
913-000-086	CCMT 32.50.5-ZX3								•								
913-000-084										•							
913-000-089								•									
913-000-090	CCMT 32.51-ZX3								•								
913-000-088										•							
913-000-093								•									
913-000-094	CCMT 32.52-ZX3								•								
913-000-092										•							
913-000-097								•									
913-000-098	CCMT 431-ZX3								•								
913-000-096										•							
913-000-101								•									
913-000-102	CCMT 432-ZX3								•								
913-000-100										•							



LX6

PRODUCT #	DESIGNATION	Grade															
		HP230	HP250	HM240	HM250	HS220	HN432	HK036	UD51	UD52	UD21	UD2	UD22	UD32	UD5C	UD5CT	UD1
913-000-207	CPMT 1.81.20.5-LX6								•								
913-000-208										•							
913-000-206											•						
913-000-205												•					
913-000-209													•			•	
913-000-210																	•
913-000-213	CPMT 1.81.21-LX6								•								
913-000-214										•							
913-000-212											•						
913-000-211												•					
913-000-215																•	
913-000-216																	•
913-000-219	CPMT 21.50.5-LX6								•								
913-000-220										•							
913-000-218											•						
913-000-217												•					
913-000-221																•	
913-000-222																	•
913-000-225	CPMT 21.51-LX6								•								
913-000-226										•							
913-000-224											•						
913-000-223												•					
913-000-227																•	
913-000-228																	•
913-000-231	CPMT 21.52-LX6								•								
913-000-232										•							
913-000-230											•						
913-000-229												•					
913-000-233																•	
913-000-234																	•
913-000-237	CPMT 32.51-LX6								•								
913-000-238										•							
913-000-236											•						
913-000-235												•					
913-000-241	CPMT 32.52-LX6								•								
913-000-242										•							
913-000-240											•						
913-000-239												•					

PACKAGE SIZE OF 10



PRODUCT #	DESIGNATION	Grade															
		HP230	HP250	HM240	HM250	HS220	HN432	HK036	UD51	UD52	UD21	UD2	UD22	UD32	UD5C	UD5CT	UD1
914-000-049	DCGT 21.50-CM1			•													
914-000-052	DCGT 32.50-CM1			•													
914-000-050	DCGT 21.50-CN1						•										
914-000-051	DCGT 21.51-CN1						•										
914-000-053	DCGT 32.51-CN1						•										
914-000-054	DCGT 32.52-CN1						•										
914-000-059			•														
914-000-058	DCMT 21.51-CX1				•												
914-000-057							•										
914-000-061			•														
914-000-060	DCMT 21.52-CX1				•												
914-000-066		•															
914-000-067			•														
914-000-065	DCMT 32.51-CX1				•												
914-000-064							•										
914-000-070		•															
914-000-071	DCMT 32.52-CX1		•														
914-000-069					•												
914-000-068							•										
914-000-056			•														
914-000-055	DCMT 21.50.5-CX2				•												
914-000-063			•														
914-000-062	DCMT 32.50.5-CX2				•												
913-000-258								•									
913-000-259	DCMT 21.50.5-LX6								•								
913-000-257										•							
913-000-260	DCMT 21.50.5-ZM1												•				
913-000-261	DCMT 21.51-ZM1												•				
913-000-265	DCMT 32.51-ZM1												•				
913-000-269	DCMT 32.52-ZM1												•				
913-000-253	DCGX 21.50.5-ZN1																•
913-000-254	DCGX 21.51-ZN1																•
913-000-255	DCGX 32.51-ZN1																•
913-000-256	DCGX 32.52-ZN1																•
913-000-263								•									
913-000-264	DCMT 21.51-ZX3								•								
913-000-262										•							
913-000-267								•			•						
913-000-268	DCMT 32.51-ZX3								•								
913-000-266										•							
913-000-271								•									
913-000-272	DCMT 32.52-ZX3								•								
913-000-270										•							
913-000-302								•									
913-000-303									•								
913-000-300	DPMT 32.51-LX6									•							
913-000-299											•						
913-000-301												•					
913-000-307								•									
913-000-308									•								
913-000-305	DPMT 32.52-LX6									•							
913-000-304											•						
913-000-306												•					

PACKAGE SIZE OF 10



CN1



CX1



LX6



ZM1

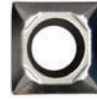

ZN1



ZX3



SCMW Flat Top

PRODUCT #	DESIGNATION	Grade															
		HP230	HP250	HM240	HM250	HS220	HN432	HK036	UD51	UD52	UD21	UD2	UD22	UD32	UD5C	UD5CT	UD1
914-000-130	SCGT 32.51-CN1						•										
914-000-133			•														
914-000-132	SCMT 32.51-CX1				•												
914-000-131								•									
914-000-136			•														
914-000-135	SCMT 32.52-CX1				•												
914-000-134								•									
914-000-138	SCMT 431-CX1		•														
914-000-137					•												
914-000-141			•														
914-000-140	SCMT 432-CX1				•												
914-000-139								•									
913-000-379									•								
913-000-380										•							
913-000-377	SCMT 21.51-LX6										•						
913-000-378												•					
913-000-381	SCMT 32.51-LX6											•					
913-000-385	SCMT 32.52-LX6											•					
913-000-382	SCMT 32.51-ZM1												•				
913-000-386	SCMT 32.52-ZM1												•				
913-000-374	SCGX 32.50.5-ZN1																•
913-000-375	SCGX 32.51-ZN1																•
913-000-376	SCGX 32.52-ZN1																•
913-000-383									•								
913-000-384	SCMT 32.51-ZX3									•							
913-000-387									•								
913-000-388	SCMT 32.52-ZX3									•							
913-000-389									•								
913-000-390	SCMT 431-ZX3									•							
913-000-391									•								
913-000-392	SCMT 432-ZX3									•							
913-000-396									•								
913-000-397										•							
913-000-394	SCMW 21.51										•						
913-000-393											•						
913-000-395												•					

PACKAGE SIZE OF 10



CX1



LX6



ZM1



ZN1



ZX3

PRODUCT #	DESIGNATION	Grade																
		HP230	HP250	HM240	HM250	HS220	HN432	HK036	UD51	UD52	UD21	UD2	UD22	UD32	UD5C	UD5CT	UD1	
914-000-151	TCMT 21.51-CX1		•															
914-000-150					•													
914-000-149								•										
914-000-154			•															
914-000-153	TCMT 21.52-CX1				•													
914-000-152								•										
914-000-157	TCMT 32.51-CX1		•															
914-000-156					•													
914-000-155								•										
914-000-160			•															
914-000-159	TCMT 32.52-CX1				•													
914-000-158								•										
913-000-437	TCMT 1.21.20.5-LX6								•									
913-000-438										•								
913-000-436												•						
913-000-439	TCMT 21.51-ZM1													•				
913-000-446	TCMT 32.51-ZM1													•				
913-000-451	TCMT 32.52-ZM1													•				
913-000-431	TCGX 21.50.5-ZN1																•	
913-000-432	TCGX 21.51-ZN1																•	
913-000-433	TCGX 21.52-ZN1																•	
913-000-434	TCGX 32.51-ZN1																•	
913-000-435	TCGX 32.52-ZN1																•	
913-000-441	TCMT 21.51-ZX3								•									
913-000-442										•								
913-000-440												•						
913-000-444										•								
913-000-445	TCMT 21.52-ZX3										•							
913-000-443													•					
913-000-449	TCMT 32.51-ZX3								•									
913-000-450										•								
913-000-447											•							
913-000-448													•					
913-000-454	TCMT 32.52-ZX3								•									
913-000-455										•								
913-000-452												•						
913-000-453													•					

PACKAGE SIZE OF 10



LX6

PRODUCT #	DESIGNATION	Grade																
		HP230	HP250	HM240	HM250	HS220	HN432	HK036	UD51	UD52	UD21	UD2	UD22	UD32	UD5C	UD5CT	UD1	
913-000-509	TPMT 21.51-LX6								•									
913-000-510										•								
913-000-508												•						
913-000-507													•					
913-000-513	TPMT 21.52-LX6								•									
913-000-514										•								
913-000-512												•						
913-000-511													•					
913-000-517	TPMT 32.51-LX6								•									
913-000-518										•								
913-000-516												•						
913-000-515													•					
913-000-521	TPMT 32.52-LX6								•									
913-000-522										•								
913-000-520												•						
913-000-519													•					



CP1



ZM1



ZX3

PRODUCT #	DESIGNATION	Grade															
		HP230	HP250	HM240	HM250	HS220	HN432	HK036	UD51	UD52	UD21	UD2	UD22	UD32	UD5C	UD5CT	UD1
914-000-175	VBMT 331-CP1		•														
914-000-176	VBMT 332-CP1		•														
913-000-539	VBMT 331-ZM1													•			
913-000-542	VBMT 332-ZM1													•			
913-000-535	VBMT 21.50.5-ZX3								•								
913-000-536										•							
913-000-537	VBMT 21.51-ZX3								•								
913-000-538										•							
913-000-540	VBMT 331-ZX3								•								
913-000-541										•							
913-000-543	VBMT 332-ZX3								•								
913-000-544										•							

PACKAGE SIZE OF 10



CX1



LX6



ZX3

PRODUCT #	DESIGNATION	Grade															
		HP230	HP250	HM240	HM250	HS220	HN432	HK036	UD51	UD52	UD21	UD2	UD22	UD32	UD5C	UD5CT	UD1
914-000-185	WCMT 21.51-CX1		•														
914-000-184					•												
914-000-187	WCMT 21.52-CX1		•														
914-000-186					•												
914-000-189	WCMT 32.51-CX1		•														
914-000-188					•												
914-000-191	WCMT 32.52-CX1		•														
914-000-190					•												
913-000-579	WCMT 21.51-LX6								•								
913-000-580										•							
913-000-578											•						
913-000-577												•					
913-000-583	WCMT 21.52-LX6								•								
913-000-584										•							
913-000-582											•						
913-000-581												•					
913-000-587	WCMT 32.51-LX6								•								
913-000-588										•							
913-000-586											•						
913-000-585												•					
913-000-591	WCMT 32.52-LX6								•								
913-000-592										•							
913-000-590											•						
913-000-589												•					
913-000-563	WCMT 1.210.5-ZX3								•								
913-000-564										•							
913-000-562											•						
913-000-561												•					
913-000-567	WCMT 1.211-ZX3								•								
913-000-568										•							
913-000-566											•						
913-000-565												•					
913-000-571	WCMT 1.51.50.5-ZX3								•								
913-000-572										•							
913-000-570											•						
913-000-569												•					
913-000-575	WCMT 1.51.51-ZX3								•								
913-000-576										•							
913-000-574											•						
913-000-573												•					

PACKAGE SIZE OF 10



PRODUCT #	DESIGNATION	Grade															
		HP230	HP250	HM240	HM250	HS220	HN432	HK036	UD51	UD52	UD21	UD2	UD22	UD32	UD5C	UD5CT	UD1
914-000-036	CNMG 321-CM2				•												
914-000-037	CNMG 322-CM2				•												
914-000-038	CNMG 431-CM2				•												
914-000-042	CNMG 432-CM2				•												
914-000-030	CNGP 431-CM3			•													
914-000-031	CNGP 432-CM3			•													
914-000-047	CNMG 543-CP2		•														
914-000-048	CNMG 643-CP2		•														
914-000-039	CNMG 431-CS1					•											
914-000-040	CNMG 431-CX1	•															
914-000-041				•													
914-000-044	CNMG 432-CX1	•															
914-000-045				•													
914-000-043									•								
914-000-046	CNMG 433-CX1							•									
913-000-177	CNMG 321-ZK1										•						
913-000-181	CNMG 322-ZK1										•						
913-000-185	CNMG 431-ZK1										•						
913-000-189	CNMG 432-ZK1										•						
913-000-193	CNMG 542-ZK1										•						
913-000-196	CNMG 543-ZK1										•						
913-000-199	CNMG 642-ZK1										•						
913-000-202	CNMG 643-ZK1										•						
913-000-178	CNMG 321-ZM1													•			
913-000-182	CNMG 322-ZM1													•			
913-000-186	CNMG 431-ZM1													•			
913-000-190	CNMG 432-ZM1													•			
913-000-179	CNMG 321-ZP1								•								
913-000-180											•						
913-000-183	CNMG 322-ZP1								•								
913-000-184											•						
913-000-187	CNMG 431-ZP1								•								
913-000-188											•						
913-000-191	CNMG 432-ZP1								•								
913-000-192											•						
913-000-194	CNMG 542-ZP1								•								
913-000-195											•						
913-000-197	CNMG 543-ZP1								•								
913-000-198											•						
913-000-200	CNMG 642-ZP1								•								
913-000-201											•						
913-000-203	CNMG 643-ZP1								•								
913-000-204											•						
914-000-032	CNMA 432								•								
914-000-033	CNMA 433								•								
914-000-034	CNMA 543								•								
914-000-035	CNMA 643								•								

PACKAGE SIZE OF 10



PRODUCT #	DESIGNATION	Grade															
		HP230	HP250	HM240	HM250	HS220	HN432	HK036	UD51	UD52	UD21	UD2	UD22	UD32	UD5C	UD5CT	UD1
914-000-075	DNMG 331-CM2				•												
914-000-077	DNMG 332-CM2				•												
914-000-079	DNMG 431-CM2				•												
914-000-081	DNMG 432-CM2				•												
914-000-072	DNGP 431-CM3			•													
914-000-076	DNMG 331-CX1		•														
914-000-078	DNMG 332-CX1		•														
914-000-080	DNMG 431-CX1		•														
914-000-082	DNMG 432-CX1		•														
913-000-294	DNMG 542-LX2							•									
913-000-295									•								
913-000-293	DNMG 543-LX2									•							
913-000-297									•								
913-000-298									•								
913-000-296											•						
913-000-277	DNMG 331-ZM1													•			
913-000-281	DNMG 332-ZM1													•			
913-000-285	DNMG 431-ZM1													•			
913-000-289	DNMG 432-ZM1													•			
913-000-278	DNMG 331-ZP1								•								
913-000-279											•						
913-000-282	DNMG 332-ZP1								•								
913-000-283											•						
913-000-286	DNMG 431-ZP1								•								
913-000-287											•						
913-000-290	DNMG 432-ZP1								•								
913-000-291											•						
913-000-280	DNMG 331-ZX2											•					
913-000-284	DNMG 332-ZX2											•					
913-000-288	DNMG 431-ZX2											•					
913-000-292	DNMG 432-ZX2											•					
914-000-073	DNMA 431								•								
914-000-074	DNMA 432								•								

PACKAGE SIZE OF 10



LX2



RNMA Flat Top

PRODUCT #	DESIGNATION	Grade															
		HP230	HP250	HM240	HM250	HS220	HN432	HK036	UD51	UD52	UD21	UD2	UD22	UD32	UD5C	UD5CT	UD1
913-000-363	RNMG 32-LX2								•								
913-000-364											•						
913-000-362	RNMG 43-LX2										•						
913-000-366												•					
913-000-367	RNMG 54-LX2											•					
913-000-365													•				
913-000-369	RNMG 64-LX2								•								
913-000-370											•						
913-000-368	RNMA 43												•				
913-000-372														•			
913-000-373	RNMA 43																
913-000-371																	
914-000-129									•								

PACKAGE SIZE OF 10



CP2



CS1



CX1



ZK1



ZM1



ZP1



ZX2



SNMA Flat Top

PRODUCT #	DESIGNATION	Grade															
		HP230	HP250	HM240	HM250	HS220	HN432	HK036	UD51	UD52	UD21	UD2	UD22	UD32	UD5C	UD5CT	UD1
914-000-147	SNMG 543-CP2		•														
914-000-148	SNMG 643-CP2		•														
914-000-144	SNMG 432-CS1					•											
914-000-146	SNMG 432-CX1		•														
914-000-145								•									
913-000-411	SNMG 643-ZK1										•						
913-000-414	SNMG 644-ZK1										•						
913-000-398	SNMG 431-ZM1													•			
913-000-402	SNMG 432-ZM1													•			
913-000-399	SNMG 431-ZP1								•								
913-000-400										•							
913-000-403	SNMG 432-ZP1								•								
913-000-404										•							
913-000-406	SNMG 542-ZP1								•								
913-000-407										•							
913-000-408	SNMG 543-ZP1								•								
913-000-409										•							
913-000-412	SNMG 643-ZP1								•								
913-000-413										•							
913-000-415	SNMG 644-ZP1								•								
913-000-416										•							
913-000-401	SNMG 431-ZX2										•						
913-000-405	SNMG 432-ZX2										•						
913-000-410	SNMG 543-ZX2										•						
914-000-142	SNMA 432							•									
914-000-143	SNMA 543							•									

PACKAGE SIZE OF 10



CM2



CS1



CX1



LX2



ZM1



ZP1



ZX2



TNMA Flat Top

PRODUCT #	DESIGNATION	Grade															
		HP230	HP250	HM240	HM250	HS220	HN432	HK036	UD51	UD52	UD21	UD2	UD22	UD32	UD5C	UD5CT	UD1
914-000-164	TNMG 331-CM2				•												
914-000-167	TNMG 332-CM2				•												
914-000-168	TNMG 332-CS1					•											
914-000-165	TNMG 331-CX1	•															
914-000-166			•														
914-000-170		•															
914-000-171	TNMG 332-CX1		•														
914-000-169								•									
914-000-172	TNMG 431-CX1		•														
914-000-174	TNMG 432-CX1		•														
914-000-173								•									
913-000-490									•								
913-000-491	TNMG 542-LX2									•							
913-000-489											•						
913-000-493									•								
913-000-494	TNMG 543-LX2									•							
913-000-492											•						
913-000-473	TNMG 331-ZM1											•					
913-000-477	TNMG 332-ZM1											•					
913-000-481	TNMG 431-ZM1											•					
913-000-485	TNMG 432-ZM1											•					
913-000-474	TNMG 331-ZP1								•								
913-000-475										•							
913-000-478	TNMG 332-ZP1								•								
913-000-479										•							
913-000-482	TNMG 431-ZP1								•								
913-000-483										•							
913-000-486	TNMG 432-ZP1								•								
913-000-487										•							
913-000-476	TNMG 331-ZX2										•						
913-000-480	TNMG 332-ZX2										•						
913-000-484	TNMG 431-ZX2										•						
913-000-488	TNMG 432-ZX2										•						
914-000-161	TNMA 332							•									
914-000-162	TNMA 432							•									
914-000-163	TNMA 543							•									

PACKAGE SIZE OF 10



PRODUCT #	DESIGNATION	Grade															
		HP230	HP250	HM240	HM250	HS220	HN432	HK036	UD51	UD52	UD21	UD2	UD22	UD32	UD5C	UD5CT	UD1
914-000-180	VNMG 332-CM2				•												
914-000-181	VNMG 332-CS1					•											
914-000-178	VNMG 331-CX1	•															
914-000-179			•														
914-000-182	VNMG 332-CX1	•															
914-000-183			•														
913-000-559	VNMG 432-LX3								•								
913-000-560										•							
913-000-558												•					
913-000-557													•				
913-000-549	VNMG 331-ZM1															•	
913-000-553	VNMG 332-ZM1															•	
913-000-551	VNMG 331-ZX2								•								
913-000-552										•							
913-000-550												•					
913-000-555									•								
913-000-556	VNMG 332-ZX2										•						
913-000-554	VNMG 332-ZX2											•					
913-000-554													•				
914-000-177	VNMA 332																•

PACKAGE SIZE OF 10



PRODUCT #	DESIGNATION	Grade															
		HP230	HP250	HM240	HM250	HS220	HN432	HK036	UD51	UD52	UD21	UD2	UD22	UD32	UD5C	UD5CT	UD1
914-000-199	WNMG 432-CM2				•												
914-000-200	WNMG 432-CS1					•											
914-000-193	WNMG 331-CX1	•															
914-000-194				•													
914-000-195	WNMG 332-CX1	•															
914-000-196				•													
914-000-197	WNMG 431-CX1	•															
914-000-198				•													
914-000-202	WNMG 432-CX1	•															
914-000-203				•													
914-000-201	WNMG 433-CX1								•								
914-000-204										•							
913-000-618	WNMG 331-ZM1																•
913-000-622	WNMG 332-ZM1																•
913-000-626	WNMG 431-ZM1																•
913-000-631	WNMG 432-ZM1																•
913-000-619	WNMG 331-ZP1								•								
913-000-620										•							
913-000-623	WNMG 332-ZP1								•								
913-000-624											•						
913-000-627	WNMG 431-ZP1								•								
913-000-628										•							
913-000-632	WNMG 432-ZP1								•								
913-000-633											•						
913-000-621	WNMG 331-ZX2																•
913-000-625	WNMG 332-ZX2																•
913-000-629	WNMG 431-ZX2																•
913-000-634	WNMG 432-ZX2																•
914-000-192	WNMA 432																•

PACKAGE SIZE OF 10



PRODUCT #	Designation	UD5CBN	UD2CBN	UD2PCD
913-000-062		•		
913-000-060	CCGW 21.51-1		•	
913-000-061				•
913-000-065		•		
913-000-063	CCGW 21.52-1		•	
913-000-064				•
913-000-068		•		
913-000-066	CCGW 32.51-2		•	
913-000-067				•
913-000-071		•		
913-000-069	CCGW 32.52-2		•	
913-000-070				•
913-000-174		•		
913-000-173	CNGA 431-2		•	
913-000-176		•		
913-000-175	CNGA 432-2		•	
913-000-248		•		
913-000-246	DCGW 21.51-1		•	
913-000-247				•
913-000-250		•		
913-000-249	DCGW 32.51-2		•	
913-000-252		•		
913-000-251	DCGW 32.52-2		•	
913-000-274		•		
913-000-273	DNGA 431-2		•	
913-000-276		•		
913-000-275	DNGA 432-2		•	

PACKAGE SIZE OF 1



PRODUCT #	Designation	UD51	UD25
913-000-460		•	
913-000-459	TDHB 1.280.750.1		•
913-000-462		•	
913-000-461	TDHB 1.280.750.5		•
913-000-464		•	
913-000-463	TDHB 1.280.751		•
913-000-495		•	
913-000-496	TPCB 220.5		•
913-000-498		•	
913-000-497	TPCB 221		•
913-000-500		•	
913-000-499	TPCB 222		•
913-000-501	TPCH 220.5-SP1	•	
913-000-502	TPCH 221-SP1	•	
913-000-456	TD 320.5	•	
913-000-457	TD 321	•	
913-000-458	TD 322	•	
913-000-504		•	
913-000-503	TPGH 321-SX1		•
913-000-506		•	
913-000-505	TPGH 322-SX1		•

PACKAGE SIZE OF 10



PRODUCT #	Designation	UD5CBN	UD2CBN	UD2PCD
913-000-420			•	
913-000-421	TCGW 21.51-1			•
913-000-424		•		
913-000-422	TCGW 21.52-1		•	
913-000-423				•
913-000-427		•		
913-000-425	TCGW 32.51-1		•	
913-000-426				•
913-000-430		•		
913-000-428	TCGW 32.52-1		•	
913-000-429				•
913-000-466		•		
913-000-465	TNGA 331-1		•	
913-000-468		•		
913-000-467	TNGA 332-1		•	
913-000-531	VBGW 21.51-1			•
913-000-532	VBGW 21.52-1			•
913-000-533	VBGW 331-1			•
913-000-534	VBGW 332-1			•
913-000-546		•		
913-000-545	VNGA 331-2		•	
913-000-548		•		
913-000-547	VNGA 332-2		•	

PACKAGE SIZE OF 1



PRODUCT #	Designation	UD51
913-000-637	WPGT 1.510-SP2	UD51
913-000-636	WPGT 1.510.5-SP2	
913-000-638	WPGT 1.511-SP2	
913-000-640	WPGT 21.50-SP2	
913-000-639	WPGT 21.50.5-SP2	
913-000-641	WPGT 21.51-SP2	
913-000-642	WPMT 32.51-SP2	
913-000-643	WPMT 32.52-SP2	

PACKAGE SIZE OF 10



CCGT



DCGT



PRODUCT #	Designation	UD2PCD
913-000-056	CCGT 21.51-CB-1 *	
913-000-057	CCGT 21.52-CB-1 *	
913-000-058	CCGT 32.51-CB-1 *	
913-000-059	CCGT 32.52-CB-1 *	
913-000-243	DCGT 21.51-CB-1 *	
913-000-244	DCGT 32.51-CB-1 *	
913-000-245	DCGT 32.52-CB-1 *	

PACKAGE SIZE OF 1

PRODUCT #	Designation	UD2PCD
913-000-529	VBGT 331-CB-1 *	
913-000-530	VBGT 332-CB-1 *	

PACKAGE SIZE OF 1

PRODUCT #	Designation	UD2PCD
913-000-417	TCGT 21.51-CB-1 *	
913-000-418	TCGT 32.51-CB-1 *	
913-000-419	TCGT 32.52-CB-1 *	

PACKAGE SIZE OF 1

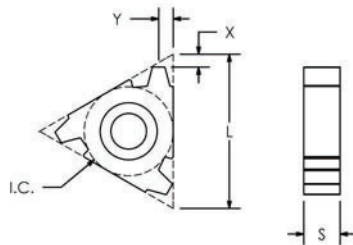

American Acme

PRODUCT #	Designation	PRODUCT #	Designation	I.C.	L	S	Pitch (tpi)	X	Y	Anvil Right	Anvil Left	UD51
	Right Hand		Left Hand									
913-000-017	3IR16ACME	913-000-005	3IL16ACME	3/8"	0.630	0.156	16	0.040	0.040	Y13	YE3	
913-000-018	3IR14ACME	913-000-006	3IL14ACME	3/8"	0.630	0.156	14	0.040	0.050	Y13	YE3	
913-000-019	3IR12ACME	913-000-007	3IL12ACME	3/8"	0.630	0.156	12	0.050	0.050	Y13	YE3	
913-000-020	3IR10ACME	913-000-008	3IL10ACME	3/8"	0.630	0.156	10	0.050	0.050	Y13	YE3	
913-000-021	3IR8ACME	913-000-009	3IL8ACME	3/8"	0.630	0.156	8	0.060	0.060	Y13	YE3	

PACKAGE SIZE OF 10

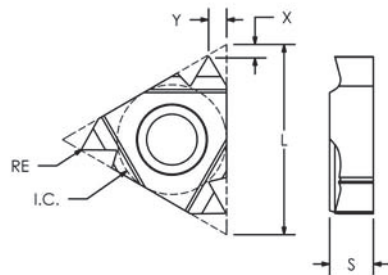

Partial Profile 60°

PRODUCT #	Designation	PRODUCT #	Designation	I.C.	L	S	Pitch (mm)	Pitch (tpi)	RE	X	Y	Anvil Right	Anvil Left	UD51
	Right Hand		Left Hand											
913-000-004	2JIRA60	913-000-002	2JILA60	1/4"	0.630	0.125	.7-1.5	36-18	0.004	0.040	0.045	Y13	YE3	
913-000-003	2JIR12UN	913-000-001	2JIL12UN	1/4"	0.630	0.125	1.0-2.0	28-12	0.004	0.030	0.035	Y13	YE3	
913-000-022	3IRA60	913-000-010	3ILA60	3/8"	0.630	0.156	.05-1.5	48-16	0.002	0.030	0.040	Y13	YE3	
913-000-023	3IRG60	913-000-011	3ILG60	3/8"	0.630	0.156	1.75-3.0	14-8	0.006	0.050	0.070	Y13	YE3	
913-000-024	3IRAG60	913-000-012	3ILAG60	3/8"	0.630	0.156	.05-3.0	48-8	0.002	0.050	0.070	Y13	YE3	
913-000-025	3JIRA60	N/A	N/A	3/8" SCB	0.630	0.156	.05-1.5	48-16	0.002	0.020	0.030	Y13	N/A	
913-000-026	3JIRG60	N/A	N/A	3/8" SCB	0.630	0.156	1.75-3.0	14-8	0.006	0.040	0.060	Y13	N/A	
913-000-027	3JIRAG60	N/A	N/A	3/8" SCB	0.630	0.156	.05-3.0	48-8	0.002	0.040	0.060	Y13	N/A	

PACKAGE SIZE OF 10

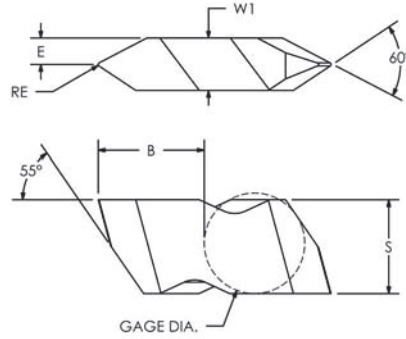

Top Notch Threading

PRODUCT #	Designation	PRODUCT #	Designation	S	W1	E	RE	Ext. TPI	Int. TPI	B	GAGE DIA.	UD51
	Right Hand		Left Hand									
913-000-332	NTP-2R	913-000-331	NTP-2L	0.219	0.150	0.075	.003/.005	8-36	1-20	0.266	0.187	
913-000-334	NTP-3R	913-000-333	NTP-3L	0.344	0.195	0.098	.005/.008	6-20	5-12	0.400	0.375	
913-000-336	NTP-4R	913-000-335	NTP-4L	0.453	0.255	0.128	.005/.008	4-20	4-12	0.629	0.375	

PACKAGE SIZE OF 1

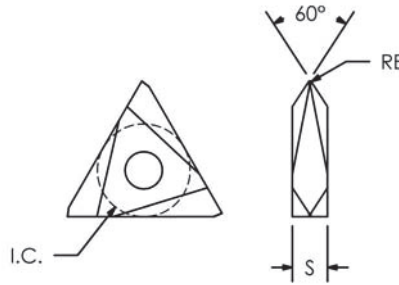

On Edge

PRODUCT #	Designation	I.C.	S	RE	TPI	UD51
	Right Hand					
913-000-469	TNMA-43NV	0.500	0.187	0.003/0.005	5-24	
913-000-470	TNMA-43NV .010	0.500	0.187	0.001	4-20	
913-000-471	TNMC-43NV	0.500	0.187	0.003/0.005	5-24	
913-000-472	TNMC-43NV .010	0.500	0.187	0.001	4-20	

PACKAGE SIZE OF 1

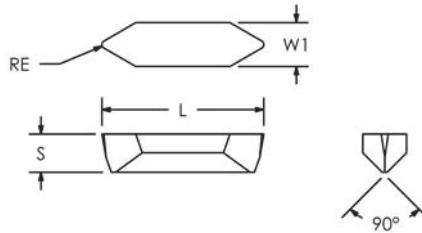

V-Bottom

PRODUCT #	Designation	W1	L	RE	S	TPI	UD51
	Right Hand						
913-000-523	V84-NV	0.250	1.000	0.006/.008	0.250	5-20	
913-000-524	V84-NV-.010R	0.250	1.000	0.010	0.250	4-20	
913-000-525	V84-NV-.020R	0.250	1.000	0.020	0.250	4-12	
913-000-526	V84-NV-.025R	0.250	1.000	0.025	0.250	4-8	
913-000-527	V84-NV-.038R	0.250	1.000	0.038	0.250	4-6	
913-000-528	V85-NV	0.312	1.000	0.006/0.008	0.250	5-20	

PACKAGE SIZE OF 1

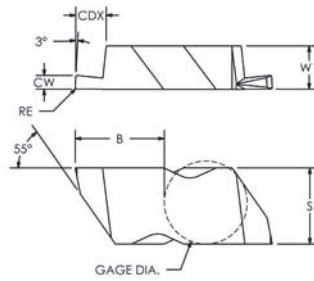

Top Notch Grooving

PRODUCT #	Designation	PRODUCT #	Designation	S	B	CDX	RE	W1	CW	GAGE DIA.	UD51
	Right Hand		Left Hand								
913-000-312	NG-2R W.031	913-000-309	NG-2L W.031	0.219	0.270	0.050	0.002 / 0.005	0.150	0.031	0.187	
913-000-313	NG-2R W.062	913-000-310	NG-2L W.062	0.219	0.270	0.110	0.005 / 0.010	0.150	0.062	0.187	
913-000-314	NG-2R W.094	913-000-311	NG-2L W.094	0.219	0.270	0.110	0.005 / 0.010	0.150	0.094	0.187	
913-000-318	NG-3R W.062	913-000-315	NG-3L W.062	0.344	0.405	0.120	0.005 / 0.010	0.195	0.062	0.375	
913-000-319	NG-3R W.094	913-000-316	NG-3L W.094	0.344	0.405	0.180	0.005 / 0.010	0.195	0.094	0.375	
913-000-320	NG-3R W.125	913-000-317	NG-3L W.125	0.344	0.405	0.180	0.005 / 0.010	0.195	0.125	0.375	
913-000-324	NG-4R W.125	913-000-321	NG-4L W.125	0.453	0.636	0.250	0.005 / 0.010	0.255	0.125	0.375	
913-000-325	NG-4R W.189	913-000-322	NG-4L W.189	0.453	0.636	0.250	0.020 / 0.025	0.255	0.189	0.375	
913-000-326	NG-4R W.250	913-000-323	NG-4L W.250	0.453	0.636	0.250	0.020 / 0.025	0.255	0.250	0.375	
913-000-327	NG-6R W.281	913-000-329	NG-6L W.281	0.453	0.636	0.250	0.030 / 0.035	0.383	0.281	0.375	
913-000-328	NG-6R W.375	913-000-330	NG-6L W.375	0.453	0.636	0.250	0.030 / 0.035	0.383	0.375	0.375	

PACKAGE SIZE OF 1

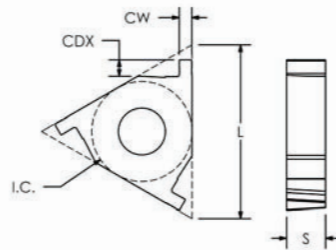

Grooving

PRODUCT #	Designation Right Hand	I.C.	S	CW	CDX	Anvil Right	UD51
913-000-013	3IR NG W.031	3/8"	0.156	0.031	0.050	YI3M-1.5N	
913-000-014	3IR NG W.047	3/8"	0.156	0.047	0.070	YI3M-1.5N	
913-000-015	3IR NG W.062	3/8"	0.156	0.062	0.080	YI3M-1.5N	
913-000-016	3IR NG W.093	3/8"	0.156	0.093	0.070	YI3	

PACKAGE SIZE OF 10

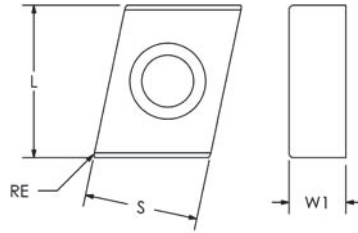

PRODUCT #	Designation Right Hand	PRODUCT #	Designation Left Hand	L	RE	S	W	UD501	UD502	UD201	UD202	UD207	UD101
913-000-111	CDE-323R02	913-000-103	CDE-323L02	0.500	0.015	0.375	0.1875				•		
913-000-112		913-000-104		0.500	0.015	0.375	0.1875					•	
913-000-113	CDE-323R05	913-000-105	CDE-323L05	0.500	0.031	0.375	0.1875						•
913-000-114		913-000-106		0.500	0.031	0.375	0.1875			•			
913-000-115		913-000-107		0.500	0.031	0.375	0.1875				•		
913-000-116		913-000-108		0.500	0.031	0.375	0.1875					•	
913-000-117		913-000-109		0.500	0.031	0.375	0.1875	•					
913-000-118		913-000-110		0.500	0.031	0.375	0.1875		•				
913-000-124	CDE-8X3R05	913-000-119	CDE-8X3L05	0.875	0.031	0.375	0.230						•
913-000-127		913-000-120		0.875	0.031	0.375	0.230				•		
913-000-128		913-000-121		0.875	0.031	0.375	0.230					•	
913-000-129		913-000-122		0.875	0.031	0.375	0.230	•					
913-000-130		913-000-123		0.875	0.031	0.375	0.230		•				

- Good
- ◐ Better
- Best

Grade	Description
UD501	TiN Coated Steel Milling Grade
UD502	TiAlN Coated Steel Milling Grade
UD201	TiN Coated Cast Iron Grade
UD202	TiAlN Coated Cast Iron Grade.
UD207	Supreme AlTiN Based Coated For High Wear Resistance
UD101	Coated Milling Insert for machining Aluminum. Excellent when machining all non-Ferrous Material.

	Steel	Stainless Steel	Cast Iron	Ferrite Materials	Heat-Resistant	Steel Hardened Metal
	P	M	K	N	S	H
UD501	●	○	○		◐	
UD502	●	○			●	
UD201		○	●			
UD202		○	●			
UD207		○	●		○	
UD101				●		



OD TURNING

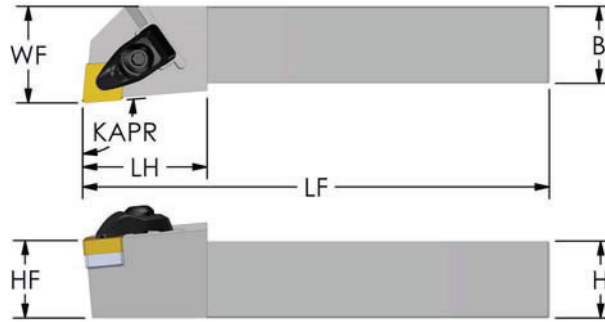

Negative 80° Diamond (KAPR: 95°)



PRODUCT # Left Hand	PRODUCT # Right hand	Designation	B	H	LF	LH	WF	HF	KAPR	Insert	Shim	Shim Screw	Clamp Assy
974-000-001	974-000-004	DCLNR/L 12-4B	0.750	0.750	4.500	1.300	1.000	0.750	95.0	CNMG 432	ICSN-433	PB4-SS	PB4-CA
974-000-002	974-000-005	DCLNR/L 16-4D	1.000	1.000	6.000	1.600	1.250	1.000	95.0	CNMG 432	ICSN-433	PB4-SS	PB4-CA
974-000-003	974-000-006	DCLNR/L 20-4D	1.250	1.250	6.000	1.600	1.500	1.250	95.0	CNMG 432	ICSN-433	PB4-SS	PB4-CA

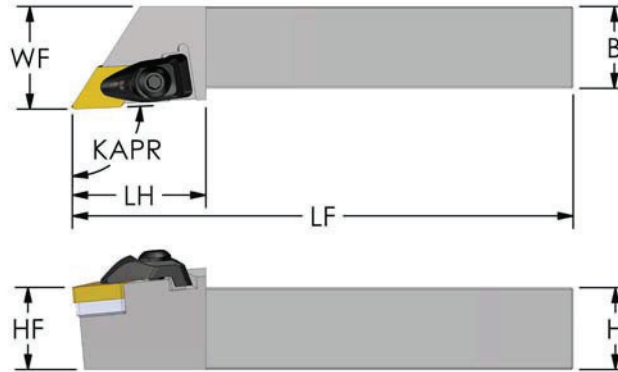

Negative 55° Diamond (KAPR: 93°)



PRODUCT # Left Hand	PRODUCT # Right hand	Designation	B	H	LF	LH	WF	HF	KAPR	Insert	Shim	Shim Screw	Clamp Assy
974-000-007	974-000-010	DDJNR/L 12-4B	0.750	0.750	4.500	1.770	1.000	0.750	93.0	DNMG 432	IDSN-433	PB4-SS	PB4-CA
974-000-008	974-000-011	DDJNR/L 16-4D	1.000	1.000	6.000	1.600	1.250	1.000	93.0	DNMG 432	IDSN-433	PB4-SS	PB4-CA
974-000-009	974-000-012	DDJNR/L 20-4D	1.250	1.250	6.000	1.600	1.500	1.250	93.0	DNMG 432	IDSN-433	PB4-SS	PB4-CA

PRODUCT #	Shim Seat
968-000-053	ICSN-433
968-000-054	ICSN-533
968-000-055	ICSN-633
968-000-063	ISSN-432
968-000-064	ISSN-433
968-000-065	ISSN-533
968-000-066	ISSN-633
968-000-056	IDSN-322
968-000-057	IDSN-433
968-000-058	IDSN-533
968-000-067	ITSN-323
968-000-068	ITSN-433

PRODUCT #	Shim Seat
968-000-069	ITSN-533
968-000-070	ITSN-636
968-000-071	IVSN-322
968-000-072	IVSN-432
968-000-073	IVSN-433
968-000-074	IWSN-322
968-000-075	IWSN-433
968-000-059	IRSN-32
968-000-060	IRSN-43
968-000-061	IRSN-53
968-000-062	IRSN-63

PACKAGE SIZE OF 10

PRODUCT #	Lock Pin
968-000-097	NL-33
968-000-098	NL-33L
968-000-099	NL-34
968-000-100	NL-34L
968-000-101	NL-44
968-000-102	NL-46
968-000-103	NL-56
968-000-104	NL-58
968-000-105	NL-68
968-000-106	NL-68L

PACKAGE SIZE OF 5

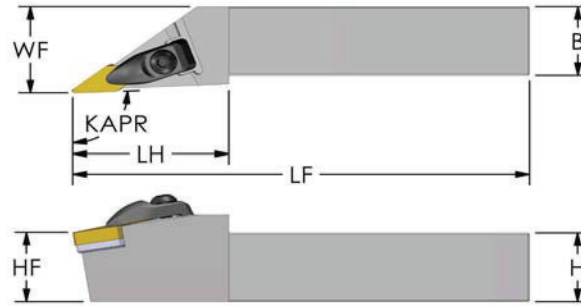

Negative 35° Diamond (KAPR: 93°)

PRODUCT # Left Hand	PRODUCT # Right hand	Designation	B	H	LF	LH	WF	HF	KAPR	Insert	Shim	Shim Screw	Clamp Assy
974-000-013	974-000-016	DVJNR/L 12-3B	0.750	0.750	4.500	1.770	1.000	0.750	93.0	VNMG 332	IVSN-322	PB3-SS	PB3L-CA
974-000-014	974-000-017	DVJNR/L 16-3D	1.000	1.000	6.000	1.600	1.250	1.000	93.0	VNMG 332	IVSN-322	PB3-SS	PB3L-CA
974-000-015	974-000-018	DVJNR/L 20-3D	1.250	1.250	6.000	1.600	1.500	1.250	93.0	VNMG 332	IVSN-322	PB3-SS	PB3L-CA

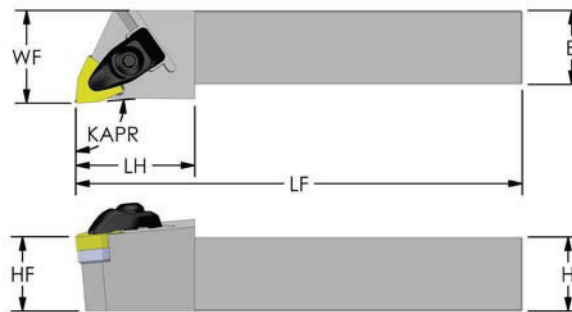

Negative Trigon (KAPR: 95°)

PRODUCT # Left Hand	PRODUCT # Right hand	Designation	B	H	LF	LH	WF	HF	KAPR	Insert	Shim	Shim Screw	Clamp Assy
974-000-019	974-000-022	DWLNR/L 12-4B	0.750	0.750	4.500	1.300	1.000	0.750	95.0	WNMG 432	IWSN-433	PB4-SS	PB4-CA
974-000-020	974-000-023	DWLNR/L 16-4D	1.000	1.000	6.000	1.600	1.250	1.000	95.0	WNMG 432	IWSN-433	PB4-SS	PB4-CA
974-000-021	974-000-024	DWLNR/L 20-4D	1.250	1.250	6.000	1.600	1.500	1.250	95.0	WNMG 432	IWSN-433	PB4-SS	PB4-CA

PRODUCT #	Clamp
968-000-016	CL-6
968-000-017	CL-7
968-000-020	CL-9
968-000-010	CL-12
968-000-011	CL-19
968-000-012	CL-20

PRODUCT #	Clamp
968-000-013	CL-21
968-000-014	CL-22
968-000-015	CL-30
968-000-018	CL-84
968-000-019	CL-85

PACKAGE SIZE OF 1

PRODUCT #	Clamp Screw
968-000-176	XNS-36
968-000-177	XNS-47
968-000-178	XNS-48
968-000-179	XNS-510
968-000-180	XNS-58
968-000-181	XNS-59

PACKAGE SIZE OF 5

ULTRA-DEX[®]

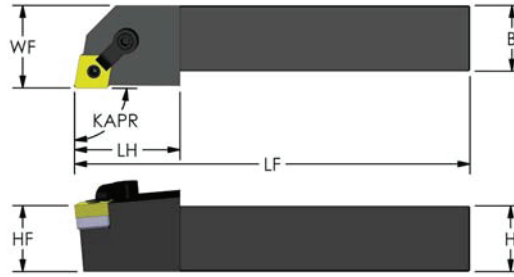

Negative 80° Diamond (KAPR: 90°)

PRODUCT # Left hand	PRODUCT # Right hand	Designation	B	H	LF	LH	WF	HF	KAPR	Insert	Shim	Lock Pin	Clamp	Screw
974-000-029	974-000-038	MCGNR/L 12-4B	0.750	0.750	4.500	1.300	1.000	0.750	90.0	CNMG 432	ICSN-433	NL-46	CL-20	XNS-48
974-000-030	974-000-039	MCGNR/L 16-4D	1.000	1.000	6.000	1.600	1.250	1.000	90.0	CNMG 432	ICSN-433	NL-46	CL-20	XNS-48
974-000-032	974-000-041	MCGNR/L 20-4D	1.250	1.250	6.000	1.600	1.500	1.250	90.0	CNMG 432	ICSN-433	NL-46	CL-20	XNS-48
974-000-035	974-000-044	MCGNR/L 24-4D	1.500	1.500	6.000	1.600	2.000	1.500	90.0	CNMG 432	ICSN-433	NL-46	CL-20	XNS-48
974-000-031	974-000-040	MCGNR/L 16-5D	1.000	1.000	6.000	1.600	1.250	1.000	90.0	CNMG 543	ICSN-533	NL-58	CL-12	XNS-510
974-000-033	974-000-042	MCGNR/L 20-5D	1.250	1.250	6.000	1.600	1.500	1.250	90.0	CNMG 543	ICSN-533	NL-58	CL-12	XNS-510
974-000-036	974-000-045	MCGNR/L 24-5D	1.500	1.500	6.000	1.600	2.000	1.500	90.0	CNMG 543	ICSN-533	NL-58	CL-12	XNS-510
974-000-034	974-000-043	MCGNR/L 20-6D	1.250	1.250	6.000	1.600	1.500	1.250	90.0	CNMG 643	ICSN-633	NL-68	CL-12	XNS-510
974-000-037	974-000-046	MCGNR/L 24-6D	1.500	1.500	6.000	1.600	2.000	1.500	90.0	CNMG 643	ICSN-633	NL-68	CL-12	XNS-510

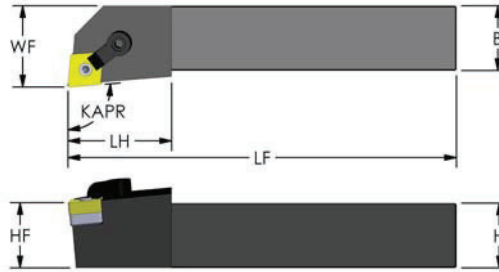

Negative 80° Diamond (KAPR: 95°)



PRODUCT # Left hand	PRODUCT # Right hand	Designation	B	H	LF	LH	WF	HF	KAPR	Insert	Shim	Lock Pin	Clamp	Screw
974-000-065	974-000-075	MCLNR/L 12-4B	0.750	0.750	4.500	1.300	1.000	0.750	95.0	CNMG 432	ICSN-433	NL-46	CL-20	XNS-48
974-000-066	974-000-076	MCLNR/L 16-4D	1.000	1.000	6.000	1.600	1.250	1.000	95.0	CNMG 432	ICSN-433	NL-46	CL-20	XNS-48
974-000-069	974-000-079	MCLNR/L 20-4D	1.250	1.250	6.000	1.600	1.500	1.250	95.0	CNMG 432	ICSN-433	NL-46	CL-20	XNS-48
974-000-067	974-000-077	MCLNR/L 16-5D	1.000	1.000	6.000	1.600	1.250	1.000	95.0	CNMG 543	ICSN-533	NL-58	CL-12	XNS-510
974-000-070	974-000-080	MCLNR/L 20-5D	1.250	1.250	6.000	1.600	1.570	1.250	95.0	CNMG 543	ICSN-533	NL-58	CL-12	XNS-510
974-000-072	974-000-082	MCLNR/L 24-5D	1.500	1.500	6.000	1.600	2.000	1.500	95.0	CNMG 543	ICSN-533	NL-58	CL-12	XNS-510
974-000-068	974-000-078	MCLNR/L 16-6D	1.000	1.000	6.000	1.600	1.250	1.000	95.0	CNMG 643	ICSN-633	NL-68	CL-12	XNS-510
974-000-071	974-000-081	MCLNR/L 20-6D	1.250	1.250	6.000	1.600	1.570	1.250	95.0	CNMG 643	ICSN-633	NL-68	CL-12	XNS-510
974-000-073	974-000-083	MCLNR/L 24-6D	1.500	1.500	6.000	1.600	2.000	1.500	95.0	CNMG 643	ICSN-633	NL-68	CL-12	XNS-510
974-000-074	974-000-084	MCLNR/L 24-6E	1.500	1.500	7.000	1.600	2.000	1.500	95.0	CNMG 643	ICSN-633	NL-68	CL-12	XNS-510

PRODUCT #	Shim Seat
968-000-053	ICSN-433
968-000-054	ICSN-533
968-000-055	ICSN-633
968-000-063	ISSN-432
968-000-064	ISSN-433
968-000-065	ISSN-533
968-000-066	ISSN-633
968-000-056	IDSN-322
968-000-057	IDSN-433
968-000-058	IDSN-533
968-000-067	ITSN-323
968-000-068	ITSN-433

PRODUCT #	Shim Seat
968-000-069	ITSN-533
968-000-070	ITSN-636
968-000-071	IVSN-322
968-000-072	IVSN-432
968-000-073	IVSN-433
968-000-074	IWSN-322
968-000-075	IWSN-433
968-000-059	IRSN-32
968-000-060	IRSN-43
968-000-061	IRSN-53
968-000-062	IRSN-63

PRODUCT #	Lock Pin
968-000-097	NL-33
968-000-098	NL-33L
968-000-099	NL-34
968-000-100	NL-34L
968-000-101	NL-44
968-000-102	NL-46
968-000-103	NL-56
968-000-104	NL-58
968-000-105	NL-68
968-000-106	NL-68L

PACKAGE SIZE OF 5

PACKAGE SIZE OF 10

ULTRA-DEX[®]

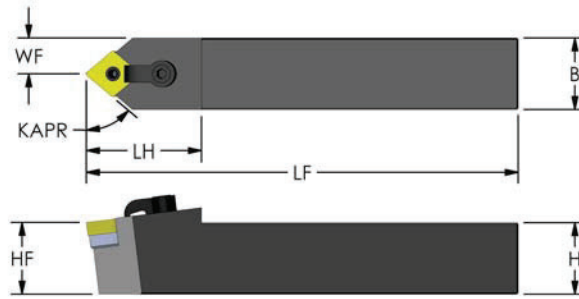

Negative 80° Diamond (KAPR: 50°)

PRODUCT #	Designation	B	H	LF	LH	WF	HF	KAPR	Insert	Shim	Lock Pin	Clamp	Screw
974-000-085	MCMNN 12-4B	0.750	0.750	4.500	1.300	0.3750	0.750	50.0	CNMG 432	ICSN-433	NL-46	CL-20	XNS-48
974-000-086	MCMNN 16-4D	1.000	1.000	6.000	1.600	0.5000	1.000	50.0	CNMG 432	ICSN-433	NL-46	CL-20	XNS-48
974-000-088	MCMNN 20-4D	1.250	1.250	6.000	1.600	0.5000	1.250	50.0	CNMG 432	ICSN-433	NL-46	CL-20	XNS-48
974-000-087	MCMNN 16-5D	1.000	1.000	6.000	1.600	0.6250	1.000	50.0	CNMG 543	ICSN-533	NL-58	CL-12	XNS-510
974-000-089	MCMNN 20-5D	1.250	1.250	6.000	1.600	0.6250	1.250	50.0	CNMG 543	ICSN-533	NL-58	CL-12	XNS-510
974-000-090	MCMNN 24-5D	1.500	1.500	6.000	1.600	0.7500	1.500	50.0	CNMG 543	ICSN-533	NL-58	CL-12	XNS-510
974-000-091	MCMNN 24-6D	1.500	1.500	6.000	2.050	0.7500	1.500	50.0	CNMG 643	ICSN-633	NL-68	CL-12	XNS-510
974-000-092	MCMNN 24-6E	1.500	1.500	7.000	2.050	0.7500	1.500	50.0	CNMG 643	ICSN-633	NL-68	CL-12	XNS-510

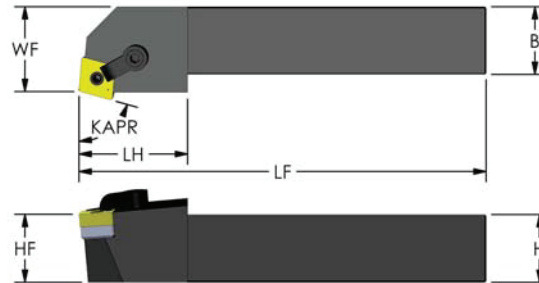

Negative 80° Diamond (KAPR: 75°)

PRODUCT # Left hand	PRODUCT # Right hand	Designation	B	H	LF	LH	WF	HF	KAPR	Insert	Shim	Lock Pin	Clamp	Screw
974-000-093	974-000-103	MCRNR/L 12-4B	0.750	0.750	4.500	1.300	0.750	0.750	75.0	CNMG 432	ICSN-433	NL-46	CL-20	XNS-48
974-000-094	974-000-104	MCRNR/L 16-4C	1.000	1.000	5.000	1.600	1.250	1.000	75.0	CNMG 432	ICSN-433	NL-46	CL-20	XNS-48
974-000-095	974-000-105	MCRNR/L 16-4D	1.000	1.000	6.000	1.600	1.250	1.000	75.0	CNMG 432	ICSN-433	NL-46	CL-20	XNS-48
974-000-098	974-000-108	MCRNR/L 20-4D	1.250	1.250	6.000	1.600	1.500	1.250	75.0	CNMG 432	ICSN-433	NL-46	CL-20	XNS-48
974-000-101	974-000-111	MCRNR/L 24-4D	1.500	1.500	6.000	1.600	2.000	1.500	75.0	CNMG 432	ICSN-433	NL-46	CL-20	XNS-48
974-000-096	974-000-106	MCRNR/L 16-5D	1.000	1.000	6.000	1.600	1.250	1.000	75.0	CNMG 543	ICSN-533	NL-58	CL-12	XNS-510
974-000-099	974-000-109	MCRNR/L 20-5D	1.250	1.250	6.000	1.600	1.500	1.250	75.0	CNMG 543	ICSN-533	NL-58	CL-12	XNS-510
974-000-097	974-000-107	MCRNR/L 16-6D	1.000	1.000	6.000	1.600	1.250	1.000	75.0	CNMG 643	ICSN-633	NL-68	CL-12	XNS-510
974-000-100	974-000-110	MCRNR/L 20-6D	1.250	1.250	6.000	1.600	1.500	1.250	75.0	CNMG 643	ICSN-633	NL-68	CL-12	XNS-510
974-000-102	974-000-112	MCRNR/L 24-6D	1.500	1.500	6.000	1.600	2.000	1.500	75.0	CNMG 643	ICSN-633	NL-68	CL-12	XNS-510

PRODUCT #	Clamp
968-000-016	CL-6
968-000-017	CL-7
968-000-020	CL-9
968-000-010	CL-12
968-000-011	CL-19
968-000-012	CL-20

PRODUCT #	Clamp
968-000-013	CL-21
968-000-014	CL-22
968-000-015	CL-30
968-000-018	CL-84
968-000-019	CL-85

PACKAGE SIZE OF 1

PRODUCT #	Clamp Screw
968-000-176	XNS-36
968-000-177	XNS-47
968-000-178	XNS-48
968-000-179	XNS-510
968-000-180	XNS-58
968-000-181	XNS-59

PACKAGE SIZE OF 5

ULTRA-DEX[®]

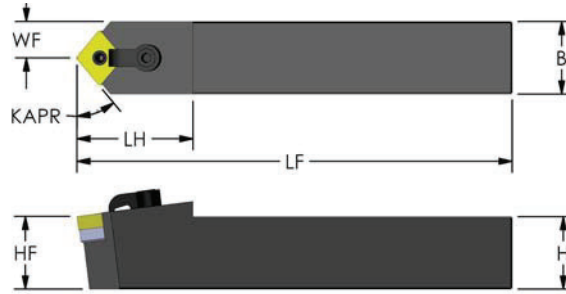

Negative 80° Diamond (KAPR: 40°)

PRODUCT #	Designation	B	H	LF	LH	HF	KAPR	Insert	Shim	Lock Pin	Clamp	Screw
974-000-113	MCYNN 12-4B	0.750	0.750	4.500	1.300	0.750	40.0	CNMG 432	ICSN-433	NL-46	CL-20	XNS-48
974-000-114	MCYNN 16-4D	1.000	1.000	6.000	1.600	1.000	40.0	CNMG 432	ICSN-433	NL-46	CL-20	XNS-48
974-000-117	MCYNN 20-4D	1.250	1.250	6.000	1.600	1.250	40.0	CNMG 432	ICSN-433	NL-46	CL-20	XNS-48
974-000-115	MCYNN 16-5D	1.000	1.000	6.000	1.600	1.000	40.0	CNMG 543	ICSN-533	NL-58	CL-12	XNS-510
974-000-118	MCYNN 20-5D	1.250	1.250	6.000	1.600	1.250	40.0	CNMG 543	ICSN-533	NL-58	CL-12	XNS-510
974-000-116	MCYNN 16-6D	1.000	1.000	6.000	2.050	1.000	40.0	CNMG 643	ICSN-633	NL-68	CL-12	XNS-510
974-000-119	MCYNN 20-6D	1.250	1.250	6.000	2.050	1.250	40.0	CNMG 643	ICSN-633	NL-68	CL-12	XNS-510
974-000-120	MCYNN 24-6D	1.500	1.500	6.000	2.050	1.500	40.0	CNMG 643	ICSN-633	NL-68	CL-12	XNS-510

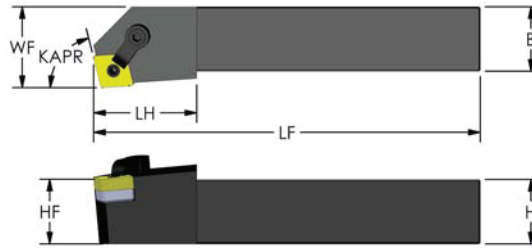

Negative 80° Diamond (KAPR: 75°)

PRODUCT # Left hand	PRODUCT # Right hand	Designation	B	H	LF	LH	WF	HF	KAPR	Insert	Shim	Lock Pin	Clamp	Screw
974-000-047	974-000-056	MCKNR/L 12-4B	0.750	0.750	4.500	1.300	1.000	0.750	75.0	CNMG 432	ICSN-433	NL-46	CL-20	XNS-48
974-000-048	974-000-057	MCKNR/L 16-4D	1.000	1.000	6.000	1.600	1.250	1.000	75.0	CNMG 432	ICSN-433	NL-46	CL-20	XNS-48
974-000-051	974-000-060	MCKNR/L 20-4D	1.250	1.250	6.000	1.600	1.500	1.250	75.0	CNMG 432	ICSN-433	NL-46	CL-20	XNS-48
974-000-049	974-000-058	MCKNR/L 16-5D	1.000	1.000	6.000	1.600	1.250	1.000	75.0	CNMG 543	ICSN-533	NL-58	CL-9	XNS-510
974-000-052	974-000-061	MCKNR/L 20-5D	1.250	1.250	6.000	1.600	1.500	1.250	75.0	CNMG 543	ICSN-533	NL-58	CL-9	XNS-510
974-000-050	974-000-059	MCKNR/L 16-6D	1.000	1.000	6.000	1.600	1.250	1.000	75.0	CNMG 643	ICSN-633	NL-68	CL-12	XNS-510
974-000-053	974-000-062	MCKNR/L 20-6D	1.250	1.250	6.000	1.600	1.500	1.250	75.0	CNMG 643	ICSN-633	NL-68	CL-12	XNS-510
974-000-054	974-000-063	MCKNR/L 24-6D	1.500	1.500	6.000	1.600	2.000	1.500	75.0	CNMG 643	ICSN-633	NL-68	CL-12	XNS-510
974-000-055	974-000-064	MCKNR/L 24-6E	1.500	1.500	7.000	1.600	2.000	1.500	75.0	CNMG 643	ICSN-633	NL-68	CL-12	XNS-510

PRODUCT #	Shim Seat
968-000-053	ICSN-433
968-000-054	ICSN-533
968-000-055	ICSN-633
968-000-063	ISSN-432
968-000-064	ISSN-433
968-000-065	ISSN-533
968-000-066	ISSN-633
968-000-056	IDSN-322
968-000-057	IDSN-433
968-000-058	IDSN-533
968-000-067	ITSN-323
968-000-068	ITSN-433

PRODUCT #	Shim Seat
968-000-069	ITSN-533
968-000-070	ITSN-636
968-000-071	IVSN-322
968-000-072	IVSN-432
968-000-073	IVSN-433
968-000-074	IWSN-322
968-000-075	IWSN-433
968-000-059	IRSN-32
968-000-060	IRSN-43
968-000-061	IRSN-53
968-000-062	IRSN-63

PRODUCT #	Lock Pin
968-000-097	NL-33
968-000-098	NL-33L
968-000-099	NL-34
968-000-100	NL-34L
968-000-101	NL-44
968-000-102	NL-46
968-000-103	NL-56
968-000-104	NL-58
968-000-105	NL-68
968-000-106	NL-68L

PACKAGE SIZE OF 5

PACKAGE SIZE OF 10

ULTRA-DEX[®]

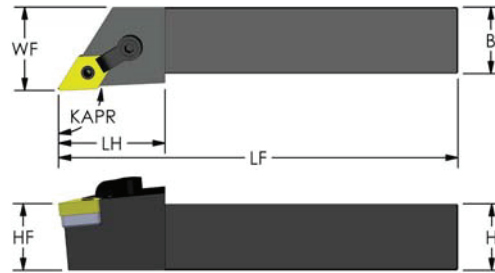

Negative 55° Diamond (KAPR: 93°)

PRODUCT # Left hand	PRODUCT # Right hand	Designation	B	H	LF	LH	WF	HF	KAPR	Insert	Shim	Lock Pin	Clamp	Screw	Price
974-000-121	974-000-128	MDJNR/L 12-4B	0.750	0.750	4.500	1.770	1.000	0.750	93.0	DNMG 432	IDSN-433	NL-46	CL-22	XNS-48	\$99.80
974-000-122	974-000-129	MDJNR/L 16-4D	1.000	1.000	6.000	1.600	1.250	1.000	93.0	DNMG 432	IDSN-433	NL-46	CL-22	XNS-48	\$112.40
974-000-124	974-000-131	MDJNR/L 20-4D	1.250	1.250	6.000	1.600	1.500	1.250	93.0	DNMG 432	IDSN-433	NL-46	CL-22	XNS-48	\$129.20
974-000-126	974-000-133	MDJNR/L 24-4D	1.500	1.500	6.000	1.600	2.000	1.500	93.0	DNMG 432	IDSN-433	NL-46	CL-22	XNS-48	\$135.50
974-000-123	974-000-130	MDJNR/L 16-5D	1.000	1.000	6.000	1.600	1.250	1.000	93.0	DNMG 543	IDSN-533	NL-58	CL-12	XNS-510	\$112.40
974-000-125	974-000-132	MDJNR/L 20-5D	1.250	1.250	6.000	1.600	1.500	1.250	93.0	DNMG 543	IDSN-533	NL-58	CL-12	XNS-510	\$129.20
974-000-127	974-000-134	MDJNR/L 24-5D	1.500	1.500	6.000	2.050	2.000	1.500	93.0	DNMG 543	IDSN-533	NL-58	CL-12	XNS-510	\$135.50

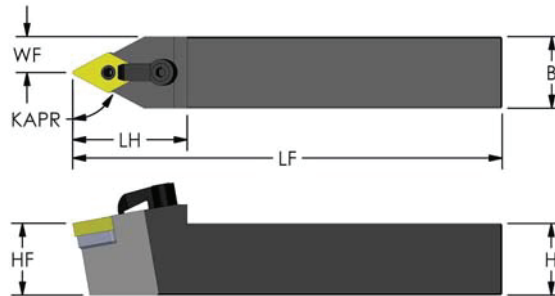

Negative 55° Diamond (KAPR: 62.5°)

PRODUCT #	Designation	B	H	LF	LH	WF	HF	KAPR	Insert	Shim	Lock Pin	Clamp	Screw	Price
974-000-135	MDPNN 12-4B	0.750	0.750	4.500	1.770	0.3750	0.750	62.5	DNMG 432	IDSN-433	NL-46	CL-22	XNS-48	\$109.20
974-000-136	MDPNN 16-4D	1.000	1.000	6.000	1.600	0.5000	1.000	62.5	DNMG 432	IDSN-433	NL-46	CL-22	XNS-48	\$113.40
974-000-138	MDPNN 20-4D	1.250	1.250	6.000	1.600	0.5000	1.250	62.5	DNMG 432	IDSN-433	NL-46	CL-22	XNS-48	\$126.00
974-000-137	MDPNN 16-5D	1.000	1.000	6.000	2.050	0.6250	1.000	62.5	DNMG 543	IDSN-533	NL-58	CL-12	XNS-510	\$113.40
974-000-139	MDPNN 20-5D	1.250	1.250	6.000	2.050	0.6250	1.250	62.5	DNMG 543	IDSN-533	NL-58	CL-12	XNS-510	\$126.00
974-000-140	MDPNN 24-5D	1.500	1.500	6.000	2.050	0.7500	1.500	62.5	DNMG 543	IDSN-533	NL-58	CL-12	XNS-510	\$135.50
974-000-141	MDPNN 24-5E	1.500	1.500	7.000	2.050	0.7500	1.500	62.5	DNMG 543	IDSN-533	NL-58	CL-12	XNS-510	\$135.50

PRODUCT #	Clamp	Price Each
968-000-016	CL-6	\$5.30
968-000-017	CL-7	\$5.30
968-000-020	CL-9	\$5.30
968-000-010	CL-12	\$5.30
968-000-011	CL-19	\$6.60
968-000-012	CL-20	\$5.30

PRODUCT #	Clamp	Price Each
968-000-013	CL-21	\$12.40
968-000-014	CL-22	\$12.60
968-000-015	CL-30	\$9.30
968-000-018	CL-84	\$28.40
968-000-019	CL-85	\$28.40

PRODUCT #	Clamp Screw	Price Each
968-000-176	XNS-36	\$2.20
968-000-177	XNS-47	\$2.20
968-000-178	XNS-48	\$2.20
968-000-179	XNS-510	\$2.20
968-000-180	XNS-58	\$2.20
968-000-181	XNS-59	\$2.20

PACKAGE SIZE OF 1

PACKAGE SIZE OF 5

ULTRA-DEX[®]

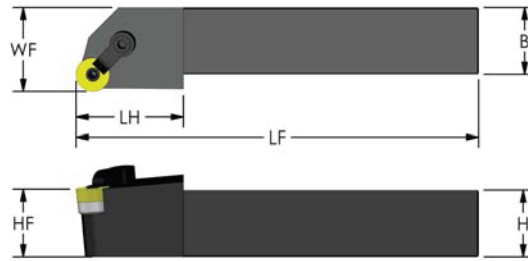

Negative Round (0° Lead)

PRODUCT # Left hand	PRODUCT # Right hand	Designation	B	H	LF	LH	WF	HF	Insert	Shim	Lock Pin	Clamp	Screw
974-000-142	974-000-151	MRGNR/L 12-3B	0.750	0.750	4.500	1.300	1.000	0.750	RNMG 32	IRSN-32	NL-34	CL-6	XNS-36
974-000-143	974-000-152	MRGNR/L 12-4B	0.750	0.750	4.500	1.300	1.000	0.750	RNMG 43	IRSN-43	NL-46	CL-20	XNS-48
974-000-144	974-000-153	MRGNR/L 16-4D	1.000	1.000	6.000	1.600	1.250	1.000	RNMG 43	IRSN-43	NL-46	CL-20	XNS-48
974-000-147	974-000-156	MRGNR/L 20-4D	1.250	1.250	6.000	1.600	1.500	1.250	RNMG 43	IRSN-43	NL-46	CL-20	XNS-48
974-000-145	974-000-154	MRGNR/L 16-5D	1.000	1.000	6.000	1.600	1.250	1.000	RNMG 54	IRSN-53	NL-58	CL-12	XNS-510
974-000-148	974-000-157	MRGNR/L 20-5D	1.250	1.250	6.000	1.600	1.500	1.250	RNMG 54	IRSN-53	NL-58	CL-12	XNS-510
974-000-146	974-000-155	MRGNR/L 16-6D	1.000	1.000	6.000	1.600	1.250	1.000	RNMG 64	IRSN-63	NL-68	CL-12	XNS-510
974-000-149	974-000-158	MRGNR/L 20-6D	1.250	1.250	6.000	1.600	1.500	1.250	RNMG 64	IRSN-63	NL-68	CL-12	XNS-510
974-000-150	974-000-159	MRGNR/L 24-6D	1.500	1.500	6.000	1.600	2.000	1.500	RNMG 64	IRSN-63	NL-68	CL-12	XNS-510

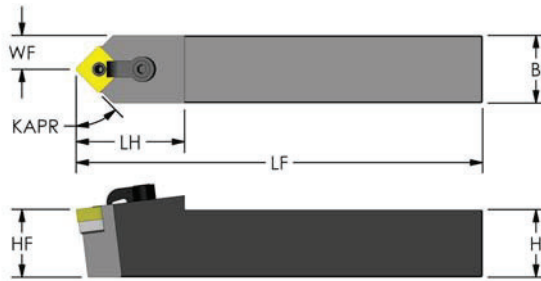

Negative Square (KAPR: 45°)

PRODUCT #	Designation	B	H	LF	LH	WF	HF	KAPR	Insert	Shim	Lock Pin	Clamp	Screw
974-000-160	MSDNN 12-4B	0.750	0.750	4.500	1.300	0.3750	0.750	45.0	SNMG 432	ISSN-433	NL-46	CL-20	XNS-48
974-000-161	MSDNN 16-4D	1.000	1.000	6.000	1.600	0.5000	1.000	45.0	SNMG 432	ISSN-433	NL-46	CL-20	XNS-48
974-000-162	MSDNN 16-5D	1.000	1.000	6.000	1.600	0.5000	1.000	45.0	SNMG 543	ISSN-533	NL-58	CL-12	XNS-510
974-000-163	MSDNN 20-5D	1.250	1.250	6.000	1.600	0.5000	1.250	45.0	SNMG 543	ISSN-533	NL-58	CL-12	XNS-510
974-000-164	MSDNN 16-6D	1.000	1.000	6.000	1.600	0.6250	1.000	45.0	SNMG 643	ISSN-633	NL-68	CL-12	XNS-510
974-000-165	MSDNN 20-6D	1.250	1.250	6.000	1.600	0.6250	1.250	45.0	SNMG 643	ISSN-633	NL-68	CL-12	XNS-510
974-000-166	MSDNN 24-6D	1.500	1.500	6.000	1.600	0.7500	1.500	45.0	SNMG 643	ISSN-633	NL-68	CL-12	XNS-510

PRODUCT #	Shim Seat
968-000-053	ICSN-433
968-000-054	ICSN-533
968-000-055	ICSN-633
968-000-063	ISSN-432
968-000-064	ISSN-433
968-000-065	ISSN-533
968-000-066	ISSN-633
968-000-056	IDSN-322
968-000-057	IDSN-433
968-000-058	IDSN-533
968-000-067	ITSN-323
968-000-068	ITSN-433

PRODUCT #	Shim Seat
968-000-069	ITSN-533
968-000-070	ITSN-636
968-000-071	IVSN-322
968-000-072	IVSN-432
968-000-073	IVSN-433
968-000-074	IWSN-322
968-000-075	IWSN-433
968-000-059	IRSN-32
968-000-060	IRSN-43
968-000-061	IRSN-53
968-000-062	IRSN-63

PRODUCT #	Lock Pin
968-000-097	NL-33
968-000-098	NL-33L
968-000-099	NL-34
968-000-100	NL-34L
968-000-101	NL-44
968-000-102	NL-46
968-000-103	NL-56
968-000-104	NL-58
968-000-105	NL-68
968-000-106	NL-68L

PACKAGE SIZE OF 5

PACKAGE SIZE OF 10

ULTRA-DEX[®]

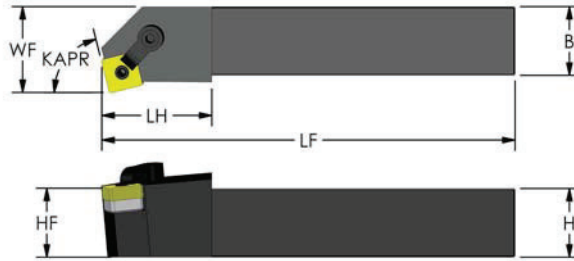

Negative Square (KAPR: 75°) End Cutting

PRODUCT # Left hand	PRODUCT # Right hand	Designation	B	H	LF	LH	WF	HF	KAPR	Insert	Shim	Lock Pin	Clamp	Screw
974-000-167	974-000-173	MSKNR/L 12-4B	0.750	0.750	4.500	1.300	1.000	0.750	75.0	SNMG 432	ISSN-433	NL-46	CL-20	XNS-48
974-000-168	974-000-174	MSKNR/L 16-4D	1.000	1.000	6.000	1.600	1.250	1.000	75.0	SNMG 432	ISSN-433	NL-46	CL-20	XNS-48
974-000-169	974-000-175	MSKNR/L 16-5D	1.000	1.000	6.000	1.600	1.250	1.000	75.0	SNMG 543	ISSN-533	NL-58	CL-12	XNS-510
974-000-170	974-000-176	MSKNR/L 20-5D	1.250	1.250	6.000	1.600	1.500	1.250	75.0	SNMG 543	ISSN-533	NL-58	CL-12	XNS-510
974-000-171	974-000-177	MSKNR/L 20-6D	1.250	1.250	6.000	1.600	1.500	1.250	75.0	SNMG 643	ISSN-633	NL-68	CL-12	XNS-510
974-000-172	974-000-178	MSKNR/L 24-6D	1.500	1.500	6.000	1.600	2.000	1.500	75.0	SNMG 643	ISSN-633	NL-68	CL-12	XNS-510

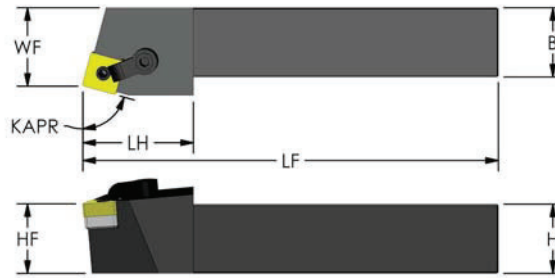

Negative Square (KAPR: 75°) Side Cutting

PRODUCT # Left hand	PRODUCT # Right hand	Designation	B	H	LF	LH	WF	HF	KAPR	Insert	Shim	Lock Pin	Clamp	Screw
974-000-179	974-000-187	MSRNR/L 12-4B	0.750	0.750	4.500	1.300	0.880	0.750	75.0	SNMG 432	ISSN-433	NL-46	CL-20	XNS-48
974-000-180	974-000-188	MSRNR/L 16-4D	1.000	1.000	6.000	1.600	1.130	1.000	75.0	SNMG 432	ISSN-433	NL-46	CL-20	XNS-48
974-000-181	974-000-189	MSRNR/L 20-4D	1.250	1.250	6.000	1.600	1.380	1.250	75.0	SNMG 432	ISSN-433	NL-46	CL-20	XNS-48
974-000-182	974-000-190	MSRNR/L 16-5D	1.000	1.000	6.000	1.600	1.103	1.000	75.0	SNMG 543	ISSN-533	NL-58	CL-12	XNS-510
974-000-183	974-000-191	MSRNR/L 20-5D	1.250	1.250	6.000	1.600	1.353	1.250	75.0	SNMG 543	ISSN-533	NL-58	CL-12	XNS-510
974-000-184	974-000-192	MSRNR/L 16-6D	1.000	1.000	6.000	1.600	1.071	1.000	75.0	SNMG 643	ISSN-633	NL-68	CL-12	XNS-510
974-000-185	974-000-193	MSRNR/L 20-6D	1.250	1.250	6.000	1.600	1.315	1.250	75.0	SNMG 643	ISSN-633	NL-68	CL-12	XNS-510
974-000-186	974-000-194	MSRNR/L 24-6D	1.500	1.500	6.000	1.600	1.821	1.500	75.0	SNMG 643	ISSN-633	NL-68	CL-12	XNS-510

PRODUCT #	Clamp
968-000-016	CL-6
968-000-017	CL-7
968-000-020	CL-9
968-000-010	CL-12
968-000-011	CL-19
968-000-012	CL-20

PRODUCT #	Clamp
968-000-013	CL-21
968-000-014	CL-22
968-000-015	CL-30
968-000-018	CL-84
968-000-019	CL-85

PACKAGE SIZE OF 1

PRODUCT #	Clamp Screw
968-000-176	XNS-36
968-000-177	XNS-47
968-000-178	XNS-48
968-000-179	XNS-510
968-000-180	XNS-58
968-000-181	XNS-59

PACKAGE SIZE OF 5

ULTRA-DEX[®]

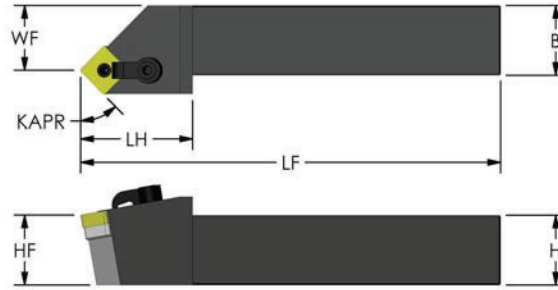

Negative Square (KAPR: 45°)



PRODUCT # Left hand	PRODUCT # Right hand	Designation	B	H	LF	LH	WF	HF	KAPR	Insert	Shim	Lock Pin	Clamp	Screw
974-000-195	974-000-201	MSSNR/L 12-4B	0.750	0.750	4.500	1.300	0.675	0.750	45.0	SNMG 432	ISSN-433	NL-46	CL-20	XNS-48
974-000-196	974-000-202	MSSNR/L 16-4D	1.000	1.000	6.000	1.600	0.925	1.000	45.0	SNMG 432	ISSN-433	NL-46	CL-20	XNS-48
974-000-197	974-000-203	MSSNR/L 16-5D	1.000	1.000	6.000	1.600	0.847	1.000	45.0	SNMG 543	ISSN-533	NL-58	CL-12	XNS-510
974-000-198	974-000-204	MSSNR/L 20-5D	1.250	1.250	6.000	1.600	1.097	1.250	45.0	SNMG 543	ISSN-533	NL-58	CL-12	XNS-510
974-000-199	974-000-205	MSSNR/L 20-6D	1.250	1.250	6.000	1.600	1.011	1.250	45.0	SNMG 643	ISSN-633	NL-68	CL-12	XNS-510
974-000-200	974-000-206	MSSNR/L 24-6D	1.500	1.500	6.000	1.600	1.511	1.500	45.0	SNMG 643	ISSN-633	NL-68	CL-12	XNS-510

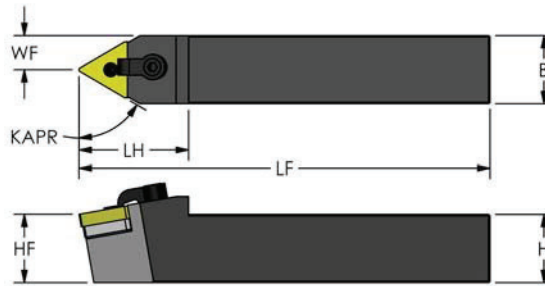

Negative Triangle (KAPR: 60°)



PRODUCT #	Designation	B	H	LF	LH	WF	HF	KAPR	Insert	Shim	Lock Pin	Clamp	Screw
974-000-219	MTENN 10-3B	0.625	0.625	4.500	1.120	0.3125	0.625	60.0	TNMG 332	ITSN-323	NL-34L	CL-6	XNS-36
974-000-220	MTENN 12-3B	0.750	0.750	4.500	1.300	0.3750	0.750	60.0	TNMG 332	ITSN-323	NL-34L	CL-6	XNS-36
974-000-221	MTENN 12-4B	0.750	0.750	4.500	1.770	0.3750	0.750	60.0	TNMG 432	ITSN-433	NL-46	CL-20	XNS-48
974-000-222	MTENN 16-4D	1.000	1.000	6.000	1.600	0.5000	1.000	60.0	TNMG 432	ITSN-433	NL-46	CL-20	XNS-48
974-000-223	MTENN 20-5D	1.250	1.250	6.000	1.600	0.6250	1.250	60.0	TNMG 543	ITSN-533	NL-58	CL-9	XNS-510
974-000-224	MTENN 24-5D	1.500	1.500	6.000	1.600	0.7500	1.500	60.0	TNMG 543	ITSN-533	NL-58	CL-9	XNS-510

PRODUCT #	Shim Seat
968-000-053	ICSN-433
968-000-054	ICSN-533
968-000-055	ICSN-633
968-000-063	ISSN-432
968-000-064	ISSN-433
968-000-065	ISSN-533
968-000-066	ISSN-633
968-000-056	IDSN-322
968-000-057	IDSN-433
968-000-058	IDSN-533
968-000-067	ITSN-323
968-000-068	ITSN-433

PRODUCT #	Shim Seat
968-000-069	ITSN-533
968-000-070	ITSN-636
968-000-071	IVSN-322
968-000-072	IVSN-432
968-000-073	IVSN-433
968-000-074	IWSN-322
968-000-075	IWSN-433
968-000-059	IRSN-32
968-000-060	IRSN-43
968-000-061	IRSN-53
968-000-062	IRSN-63

PACKAGE SIZE OF 10

PRODUCT #	Lock Pin
968-000-097	NL-33
968-000-098	NL-33L
968-000-099	NL-34
968-000-100	NL-34L
968-000-101	NL-44
968-000-102	NL-46
968-000-103	NL-56
968-000-104	NL-58
968-000-105	NL-68
968-000-106	NL-68L

PACKAGE SIZE OF 5

ULTRA-DEX[®]

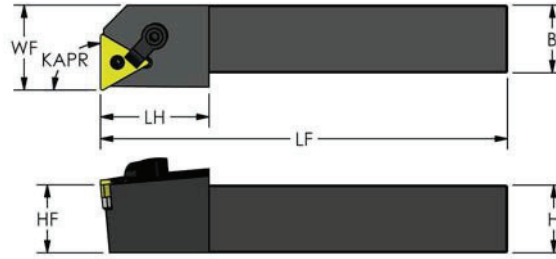

Negative Triangle (KAPR: 90°) End Cutting

PRODUCT # Left hand	PRODUCT # Right hand	Designation	B	H	LF	LH	WF	HF	KAPR	Insert	Shim	Lock Pin	Clamp	Screw
974-000-225	974-000-233	MTFNR/L 12-3B	0.750	0.750	4.500	1.300	1.000	0.750	90.0	TNMG 332	ITSN-323	NL-34L	CL-6	XNS-36
974-000-226	974-000-234	MTFNR/L 16-3D	1.000	1.000	6.000	1.600	1.250	1.000	90.0	TNMG 332	ITSN-323	NL-34L	CL-6	XNS-36
974-000-227	974-000-235	MTFNR/L 16-4D	1.000	1.000	6.000	1.600	1.250	1.000	90.0	TNMG 432	ITSN-433	NL-46	CL-20	XNS-48
974-000-228	974-000-236	MTFNR/L 20-4D	1.250	1.250	6.000	1.600	1.500	1.250	90.0	TNMG 432	ITSN-433	NL-46	CL-20	XNS-48
974-000-229	974-000-237	MTFNR/L 16-5D	1.000	1.000	6.000	1.600	1.250	1.000	90.0	TNMG 543	ITSN-533	NL-58	CL-12	XNS-510
974-000-230	974-000-238	MTFNR/L 20-5D	1.250	1.250	6.000	1.600	1.500	1.250	90.0	TNMG 543	ITSN-533	NL-58	CL-12	XNS-510
974-000-231	974-000-239	MTFNR/L 24-5D	1.500	1.500	6.000	1.600	2.000	1.500	90.0	TNMG 543	ITSN-533	NL-58	CL-12	XNS-510
974-000-232	974-000-240	MTFNR/L 24-6D	1.500	1.500	6.000	1.600	2.000	1.500	90.0	TNMG 663	ITSN-636	NL-68L	CL-12	XNS-510

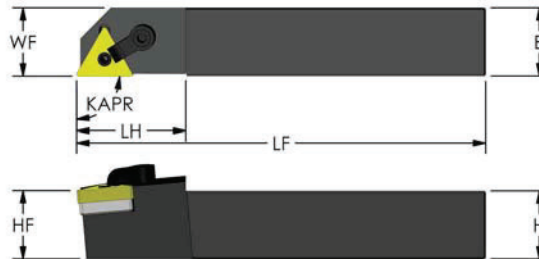

Negative Triangle (KAPR: 90°) Side Cutting

PRODUCT # Left hand	PRODUCT # Right hand	Designation	B	H	LF	LH	WF	HF	KAPR	Insert	Shim	Lock Pin	Clamp	Screw
974-000-207	974-000-213	MTANR/L 12-3B	0.750	0.750	4.500	1.300	0.750	0.750	90.0	TNMG 332	ITSN-323	NL-34L	CL-6	XNS-36
974-000-208	974-000-214	MTANR/L 16-3D	1.000	1.000	6.000	1.600	1.000	1.000	90.0	TNMG 332	ITSN-323	NL-34L	CL-6	XNS-36
974-000-209	974-000-215	MTANR/L 16-4D	1.000	1.000	6.000	1.600	1.000	1.000	90.0	TNMG 432	ITSN-433	NL-46	CL-20	XNS-48
974-000-210	974-000-216	MTANR/L 20-5D	1.250	1.250	6.000	1.600	1.250	1.250	90.0	TNMG 543	ITSN-533	NL-58	CL-12	XNS-510
974-000-211	974-000-217	MTANR/L 24-5D	1.500	1.500	6.000	1.600	1.500	1.500	90.0	TNMG 543	ITSN-533	NL-58	CL-12	XNS-510
974-000-212	974-000-218	MTANR/L 24-6D	1.500	1.500	6.000	1.600	1.500	1.500	90.0	TNMG 663	ITSN-636	NL-68L	CL-12	XNS-510

PRODUCT #	Clamp
968-000-016	CL-6
968-000-017	CL-7
968-000-020	CL-9
968-000-010	CL-12
968-000-011	CL-19
968-000-012	CL-20

PRODUCT #	Clamp
968-000-013	CL-21
968-000-014	CL-22
968-000-015	CL-30
968-000-018	CL-84
968-000-019	CL-85

PACKAGE SIZE OF 1

PRODUCT #	Clamp Screw
968-000-176	XNS-36
968-000-177	XNS-47
968-000-178	XNS-48
968-000-179	XNS-510
968-000-180	XNS-58
968-000-181	XNS-59

PACKAGE SIZE OF 5

ULTRA-DEX[®]

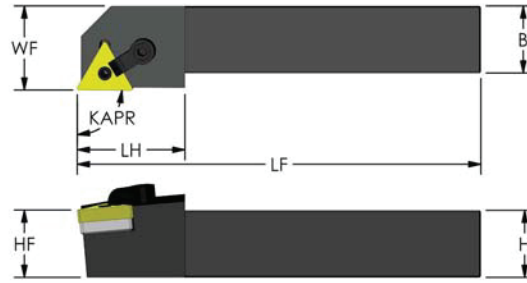

Negative Triangle (KAPR: 90°) Side Cutting

PRODUCT # Left hand	PRODUCT # Right hand	Designation	B	H	LF	LH	WF	HF	KAPR	Insert	Shim	Lock Pin	Clamp	Screw
974-000-241	974-000-251	MTGNR/L 10-3B	0.625	0.625	4.500	1.120	0.875	0.625	90.0	TNMG 332	ITSN-323	NL-34L	CL-6	XNS-36
974-000-242	974-000-252	MTGNR/L 12-3B	0.750	0.750	4.500	1.300	1.000	0.750	90.0	TNMG 332	ITSN-323	NL-34L	CL-6	XNS-36
974-000-243	974-000-253	MTGNR/L 16-3D	1.000	1.000	6.000	1.600	1.250	1.000	90.0	TNMG 332	ITSN-323	NL-34L	CL-6	XNS-36
974-000-244	974-000-254	MTGNR/L 16-4D	1.000	1.000	6.000	1.600	1.250	1.000	90.0	TNMG 432	ITSN-433	NL-46	CL-20	XNS-48
974-000-246	974-000-256	MTGNR/L 20-4D	1.250	1.250	6.000	1.600	1.500	1.250	90.0	TNMG 432	ITSN-433	NL-46	CL-20	XNS-48
974-000-248	974-000-258	MTGNR/L 24-4D	1.500	1.500	6.000	1.600	2.000	1.500	90.0	TNMG 432	ITSN-433	NL-46	CL-20	XNS-48
974-000-249	974-000-259	MTGNR/L 24-4E	1.500	1.500	7.000	1.600	2.000	1.500	90.0	TNMG 432	ITSN-433	NL-46	CL-20	XNS-48
974-000-245	974-000-255	MTGNR/L 16-5D	1.000	1.000	6.000	1.600	1.250	1.000	90.0	TNMG 543	ITSN-533	NL-58	CL-9	XNS-510
974-000-247	974-000-257	MTGNR/L 20-5D	1.250	1.250	6.000	1.600	1.500	1.250	90.0	TNMG 543	ITSN-533	NL-58	CL-9	XNS-510
974-000-250	974-000-260	MTGNR/L 24-5D	1.500	1.500	6.000	1.600	2.000	1.500	90.0	TNMG 543	ITSN-533	NL-58	CL-9	XNS-510

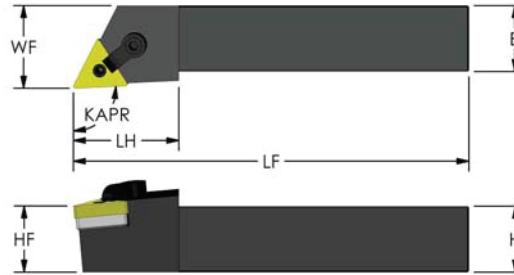

Negative Triangle (KAPR: 93°)

PRODUCT # Left hand	PRODUCT # Right hand	Designation	B	H	LF	LH	WF	HF	KAPR	Insert	Shim	Lock Pin	Clamp	Screw
974-000-261	974-000-269	MTJNR/L 12-3B	0.750	0.750	4.500	1.300	1.000	0.750	93.0	TNMG 332	ITSN-323	NL-34L	CL-6	XNS-36
974-000-262	974-000-270	MTJNR/L 16-3D	1.000	1.000	6.000	1.600	1.250	1.000	93.0	TNMG 332	ITSN-323	NL-34L	CL-6	XNS-36
974-000-263	974-000-271	MTJNR/L 16-4D	1.000	1.000	6.000	1.600	1.250	1.000	93.0	TNMG 432	ITSN-433	NL-46	CL-20	XNS-48
974-000-265	974-000-273	MTJNR/L 20-4D	1.250	1.250	6.000	1.600	1.500	1.250	93.0	TNMG 432	ITSN-433	NL-46	CL-20	XNS-48
974-000-264	974-000-272	MTJNR/L 16-5D	1.000	1.000	6.000	1.600	1.250	1.000	93.0	TNMG 543	ITSN-533	NL-58	CL-9	XNS-510
974-000-266	974-000-274	MTJNR/L 20-5D	1.250	1.250	6.000	1.600	1.500	1.250	93.0	TNMG 543	ITSN-533	NL-58	CL-9	XNS-510
974-000-267	974-000-275	MTJNR/L 24-5D	1.500	1.500	6.000	1.600	2.000	1.500	93.0	TNMG 543	ITSN-533	NL-58	CL-9	XNS-510
974-000-268	974-000-276	MTJNR/L 24-6D	1.500	1.500	6.000	1.600	2.000	1.500	93.0	TNMG 663	ITSN-636	NL-68L	CL-12	XNS-510

PRODUCT #	Shim Seat
968-000-053	ICSN-433
968-000-054	ICSN-533
968-000-055	ICSN-633
968-000-063	ISSN-432
968-000-064	ISSN-433
968-000-065	ISSN-533
968-000-066	ISSN-633
968-000-056	IDSN-322
968-000-057	IDSN-433
968-000-058	IDSN-533
968-000-067	ITSN-323
968-000-068	ITSN-433

PRODUCT #	Shim Seat
968-000-069	ITSN-533
968-000-070	ITSN-636
968-000-071	IVSN-322
968-000-072	IVSN-432
968-000-073	IVSN-433
968-000-074	IWSN-322
968-000-075	IWSN-433
968-000-059	IRSN-32
968-000-060	IRSN-43
968-000-061	IRSN-53
968-000-062	IRSN-63

PRODUCT #	Lock Pin
968-000-097	NL-33
968-000-098	NL-33L
968-000-099	NL-34
968-000-100	NL-34L
968-000-101	NL-44
968-000-102	NL-46
968-000-103	NL-56
968-000-104	NL-58
968-000-105	NL-68
968-000-106	NL-68L

PACKAGE SIZE OF 5

PACKAGE SIZE OF 10

ULTRA-DEX®

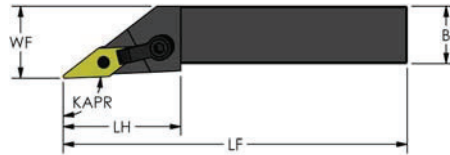

Negative 35° Diamond (KAPR: 93°)



PRODUCT # Left hand	PRODUCT # Right hand	Designation	B	H	LF	LH	WF	HF	KAPR	Insert	Shim	Lock Pin	Clamp	Screw
974-000-277	974-000-283	MVJNR/L 12-3B	0.750	0.750	4.500	1.770	1.000	0.750	93.0	VNMG 332	IVSN-322	NL-34L	CL-22	XNS-48
974-000-278	974-000-284	MVJNR/L 16-3D	1.000	1.000	6.000	1.600	1.250	1.000	93.0	VNMG 332	IVSN-322	NL-34L	CL-22	XNS-48
974-000-280	974-000-286	MVJNR/L 20-3D	1.250	1.250	6.000	1.600	1.500	1.250	93.0	VNMG 332	IVSN-322	NL-34L	CL-22	XNS-48
974-000-279	974-000-285	MVJNR/L 16-4D	1.000	1.000	6.000	2.050	1.250	1.000	93.0	VNMG 432	IVSN-432	NL-46	CL-30	XNS-510
974-000-281	974-000-287	MVJNR/L 20-4D	1.250	1.250	6.000	2.050	1.500	1.250	93.0	VNMG 432	IVSN-432	NL-46	CL-30	XNS-510
974-000-282	974-000-288	MVJNR/L 24-4D	1.500	1.500	6.000	2.050	2.000	1.500	93.0	VNMG 432	IVSN-432	NL-46	CL-30	XNS-510

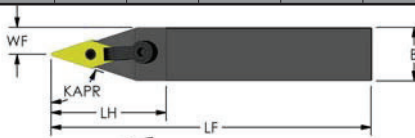

Negative 35° Diamond (KAPR: 72.5°)



PRODUCT #	Designation	B	H	LF	LH	WF	HF	KAPR	Insert	Shim	Lock Pin	Clamp	Screw
974-000-289	MVVNN 12-3B	0.750	0.750	4.500	1.770	0.3750	0.750	72.5	VNMG 332	IVSN-322	NL-34L	CL-30	XNS-510
974-000-290	MVVNN 16-3D	1.000	1.000	6.000	2.050	0.5000	1.000	72.5	VNMG 332	IVSN-322	NL-34L	CL-30	XNS-510
974-000-292	MVVNN 20-3D	1.250	1.250	6.000	2.050	0.5000	1.250	72.5	VNMG 332	IVSN-322	NL-34L	CL-30	XNS-510
974-000-294	MVVNN 24-3D	1.500	1.500	6.000	2.050	0.6250	1.500	72.5	VNMG 332	IVSN-322	NL-34L	CL-30	XNS-510
974-000-291	MVVNN 16-4D	1.000	1.000	6.000	2.050	0.6250	1.000	72.5	VNMG 432	IVSN-432	NL-46	CL-30	XNS-510
974-000-293	MVVNN 20-4D	1.250	1.250	6.000	2.050	0.7500	1.250	72.5	VNMG 432	IVSN-432	NL-46	CL-30	XNS-510
974-000-295	MVVNN 24-4D	1.500	1.500	6.000	2.050	0.7500	1.500	72.5	VNMG 432	IVSN-432	NL-46	CL-30	XNS-510

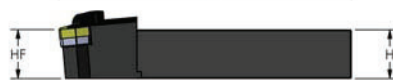
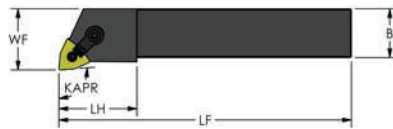

Negative Trigon (KAPR: 95°)



PRODUCT # Left hand	PRODUCT # Right hand	Designation	B	H	LF	LH	WF	HF	KAPR	Insert	Shim	Lock Pin	Clamp	Screw
974-000-296	974-000-301	MWLNR/L 12-3B	0.750	0.750	4.500	1.300	1.000	0.750	95.0	WNMG 332	IWSN-322	NL-34L	CL-6	XNS-36
974-000-297	974-000-302	MWLNR/L 12-4B	0.750	0.750	4.500	1.300	1.000	0.750	95.0	WNMG 432	IWSN-433	NL-46	CL-20	XNS-48
974-000-298	974-000-303	MWLNR/L 16-4D	1.000	1.000	6.000	1.600	1.250	1.000	95.0	WNMG 432	IWSN-433	NL-46	CL-20	XNS-48
974-000-299	974-000-304	MWLNR/L 20-4D	1.250	1.250	6.000	1.600	1.500	1.250	95.0	WNMG 432	IWSN-433	NL-46	CL-20	XNS-48
974-000-300	974-000-305	MWLNR/L 24-4D	1.500	1.500	6.000	1.600	2.000	1.500	95.0	WNMG 432	IWSN-433	NL-46	CL-20	XNS-48

PRODUCT #	Clamp
968-000-016	CL-6
968-000-017	CL-7
968-000-020	CL-9
968-000-010	CL-12
968-000-011	CL-19
968-000-012	CL-20

PRODUCT #	Clamp
968-000-013	CL-21
968-000-014	CL-22
968-000-015	CL-30
968-000-018	CL-84
968-000-019	CL-85

PRODUCT #	Clamp Screw
968-000-176	XNS-36
968-000-177	XNS-47
968-000-178	XNS-48
968-000-179	XNS-510
968-000-180	XNS-58
968-000-181	XNS-59

PACKAGE SIZE OF 1

PACKAGE SIZE OF 5

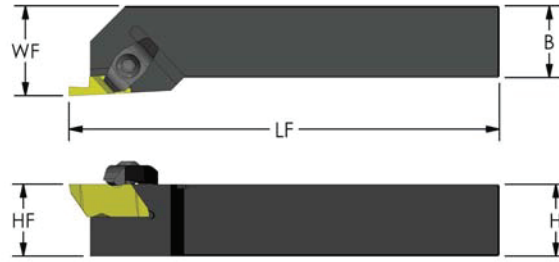

Threading/Grooving Top Notch

PRODUCT # Left hand	PRODUCT # Right hand	Designation	B	H	LF	WF	HF	Insert	RH Clamp	LH Clamp	Clamp Screw
974-000-306	974-000-310	NSR/L 12-3B	0.750	0.750	4.500	1.000	0.750	NG 3R/3L	CM-72	CM-73	10-32
974-000-307	974-000-311	NSR/L 12-4B	0.750	0.750	4.500	1.000	0.750	NG 4R/4L	CM-72	CM-73	10-32
974-000-308	974-000-312	NSR/L 16-3D	1.000	1.000	6.000	1.250	1.000	NG 3R/3L	CM-72	CM-73	10-32
974-000-309	974-000-313	NSR/L 16-4D	1.000	1.000	6.000	1.250	1.000	NG 4R/4L	CM-72	CM-73	10-32

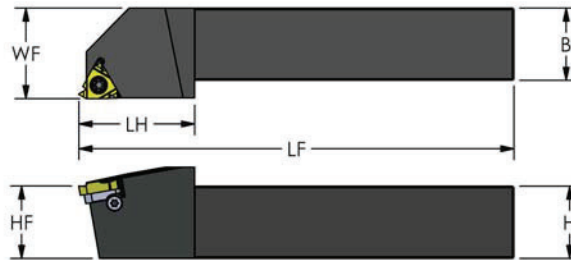

Threading/Grooving Laydown

PRODUCT # Left hand	PRODUCT # Right hand	Designation	B	H	LF	LH	WF	HF	Insert	Insert Screw	Anvil Screw	Anvil Right	Anvil Left
974-000-025	974-000-027	LSSR/L 12-3B	0.750	0.750	4.500	1.300	1.000	0.750	3 IL/IR	SA3T	SY3T	YE3	YI3
974-000-026	974-000-028	LSSR/L 16-3D	1.000	1.000	6.000	1.600	1.250	1.000	3 IL/IR	SA3T	SY3T	YE3	YI3

PRODUCT #	Clamp
968-000-016	CL-6
968-000-017	CL-7
968-000-020	CL-9
968-000-010	CL-12
968-000-011	CL-19
968-000-012	CL-20

PRODUCT #	Clamp
968-000-013	CL-21
968-000-014	CL-22
968-000-015	CL-30
968-000-018	CL-84
968-000-019	CL-85

PACKAGE SIZE OF 1

PRODUCT #	Anvil Screw
968-000-146	SY3T
968-000-147	SY4T
968-000-148	SY5T

PACKAGE SIZE OF 5

PRODUCT #	Insert Screw
968-000-124	SA3T
968-000-125	SA4T
968-000-126	SA5T

PACKAGE SIZE OF 5

ULTRA-DEX®

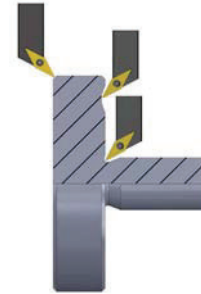

Positive 35° Diamond (KAPR: 117.5°)

PRODUCT # Left hand	PRODUCT # Right hand	Designation	B	H	LF	WF	HF	KAPR	Insert	Screw
974-000-314	974-000-317	SVTBR/L 12-2B	0.750	0.750	4.500	0.935	0.750	117.5	VBMT 21.51	MTS-2.5L
974-000-315	974-000-318	SVTBR/L 12-3B	0.750	0.750	4.500	1.050	0.750	117.5	VBMT 331	MTS-3.5L
974-000-316	974-000-319	SVTBR/L 16-3D	1.000	1.000	6.000	1.300	1.000	117.5	VBMT 331	MTS-3.5L

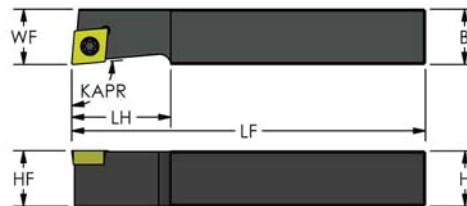

- Proper insert alignment for swiss processes
- Accepts standard ISO inserts
- Specials available upon request



Positive 80° Diamond (KAPR: 95°)

PRODUCT # Left hand	PRODUCT # Right hand	Designation	B	H	LF	LH	WF	HF	KAPR	Insert	Screw
960-000-003	960-000-007	SCLCR/L 1212-3A	12mm	12mm	100mm	22mm	22mm	12mm	95.0	CCMT 32.51	MTS-35
960-000-004	960-000-008	SCLCR/L 1616-3A	16mm	16mm	100mm	28mm	28mm	16mm	95.0	CCMT 32.51	MTS-35
960-000-001	960-000-005	SCLCR/L 08-3A	0.500	0.500	4.000	0.8650	0.865	0.500	95.0	CCMT 32.51	MTS-35
960-000-002	960-000-006	SCLCR/L 10-3A	0.625	0.625	4.000	1.1200	1.120	0.625	95.0	CCMT 32.51	MTS-35



Positive 55° Diamond (KAPR: 93°)

PRODUCT # Left hand	PRODUCT # Right hand	Designation	B	H	LF	LH	WF	HF	KAPR	Insert	Screw
960-000-011	960-000-015	SDJCR/L 1212-3A	12mm	12mm	100mm	22mm	22mm	12mm	93.0	DCMT 32.51	MTS-35
960-000-012	960-000-016	SDJCR/L 1616-3A	16mm	16mm	100mm	28mm	28mm	16mm	93.0	DCMT 32.51	MTS-35
960-000-009	960-000-013	SDJCR/L 08-3A	0.500	0.500	4.000	0.8650	0.865	0.500	93.0	DCMT 32.51	MTS-35
960-000-010	960-000-014	SDJCR/L 10-3A	0.625	0.625	4.000	1.1200	1.120	0.625	93.0	DCMT 32.51	MTS-35

PRODUCT #	Clamp Screw
968-000-176	XNS-36
968-000-177	XNS-47
968-000-178	XNS-48
968-000-179	XNS-510
968-000-180	XNS-58
968-000-181	XNS-59

PACKAGE SIZE OF 5

PRODUCT #	Anvil
968-000-185	YI3
968-000-182	YE3
968-000-187	YI4
968-000-186	YI3M-1.5N
968-000-183	YE4
968-000-188	YI5
968-000-184	YE5

PACKAGE SIZE OF 1

PRODUCT #	Insert Screws
968-000-086	MTS-183
968-000-087	MTS-184
968-000-088	MTS-2
968-000-091	MTS-224
968-000-092	MTS-255
968-000-094	MTS-35
968-000-090	MTS-2.5L
968-000-052	ETS 4-40

PACKAGE SIZE OF 5

ARCH[®]
Cutting Tools

ID TURNING

THE COMPLETE TOOL MAKING AUTHORITY[®]

STEEL BORING BARS

The economical choice
for general machining

Up to 4:1 Ratio

.156"-2" Diameters



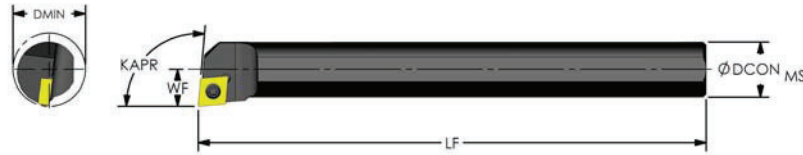

ULTRA-DEX[®]



Positive 80° Diamond (KAPR: 95°)

**4:1 Ratio
No Coolant**

PRODUCT # Left hand	PRODUCT # Right hand	Designation	DCON MS	LF	WF	DMIN	Insert	Insert Screw	Key
957-000-207	957-000-208	S02.5G SCLDR/L1.2 *	0.156	3.500	0.090	0.175	CDHB 1.20.60	MTS-182	T-6
957-000-211	957-000-212	S03G SCLDR/L1.2 *	0.187	3.500	0.102	0.205	CDHB 1.20.60	MTS-183	T-6
957-000-209	957-000-210	S03.5G SCLDR/L1.5 *	0.218	3.500	0.125	0.245	CDGW 1.510	MTS-184	T-6
957-000-214	957-000-216	S04G SCLDR/L1.5 *	0.250	3.500	0.172	0.312	CDGW 1.510	MTS-184	T-6
957-000-228	957-000-230	S05G SCLPR/L1.8 *	0.312	3.500	0.219	0.395	CPMT 1.81.20.5	MTS-224	T-7
957-000-248	957-000-250	S06K SCLPR/L2	0.375	5.000	0.250	0.460	CPMT 21.51	MTS-255	T-7
957-000-280	957-000-283	S08M SCLPR/L2	0.500	6.000	0.312	0.600	CPMT 21.51	MTS-255	T-7
957-000-317	957-000-319	S10Q SCLPR/L2	0.625	7.000	0.406	0.760	CPMT 21.51	MTS-255	T-7
957-000-282	957-000-285	S08M SCLPR/L3	0.500	6.000	0.344	0.625	CPMT 32.51	MTS-35	T-15
957-000-318	957-000-320	S10Q SCLPR/L3	0.625	7.000	0.406	0.760	CPMT 32.51	MTS-35	T-15
957-000-341	957-000-342	S12Q SCLPR/L3	0.750	7.000	0.500	0.920	CPMT 32.51	MTS-35	T-15
957-000-372	957-000-373	S16R SCLPR/L3	1.000	8.000	0.625	1.185	CPMT 32.51	MTS-35	T-15
957-000-244	957-000-246	S06K SCLCR/L2	0.375	5.000	0.250	0.460	CCMT 21.51	MTS-255	T-7
957-000-274	957-000-277	S08M SCLCR/L2	0.500	6.000	0.312	0.600	CCMT 21.51	MTS-255	T-7
957-000-313	957-000-315	S10Q SCLCR/L2	0.625	7.000	0.406	0.760	CCMT 21.51	MTS-255	T-7
957-000-276	957-000-279	S08M SCLCR/L3	0.500	6.000	0.344	0.625	CCMT 32.51	MTS-35	T-15
957-000-314	957-000-316	S10Q SCLCR/L3	0.625	7.000	0.406	0.760	CCMT 32.51	MTS-35	T-15
957-000-339	957-000-340	S12Q SCLCR/L3	0.750	7.000	0.500	0.920	CCMT 32.51	MTS-35	T-15
N/A	957-000-367	S12S SCLCR3	0.750	10.000	0.500	0.920	CCMT 32.51	MTS-35	T-15
957-000-370	957-000-371	S16R SCLCR/L3	1.000	8.000	0.625	1.185	CCMT 32.51	MTS-35	T-15
N/A	957-000-401	S16T SCLCR3	1.000	12.000	0.625	1.185	CCMT 32.51	MTS-35	T-15
957-000-425	957-000-427	S20U SCLCR/L3	1.250	14.000	0.765	1.465	CCMT 32.51	MTS-35	T-15
957-000-428	957-000-428	S20U SCLCR/L4	1.250	14.000	0.765	1.465	CCMT 432	MTS-4	T-20
957-000-440	957-000-441	S24U SCLCR/L4	1.500	14.000	0.890	1.730	CCMT 432	MTS-4	T-20

Minimum Clearance

No Coolant

PRODUCT # Left hand	PRODUCT # Right hand	Designation	DCON MS	LF	WF	DMIN	Insert	Insert Screw	Key
957-000-215	957-000-217	S04G SCLDR/L1.5-138 *	0.250	3.500	0.138	0.275	CDGW 1.510	MTS-184	T-6
957-000-229	957-000-231	S05G SCLPR/L1.8-167 *	0.312	3.500	0.167	0.340	CPMT 1.81.20.5	MTS-224	T-7
957-000-249	957-000-251	S06K SCLPR/L2-203	0.375	5.000	0.203	0.410	CPMT 21.51	MTS-255	T-7
957-000-281	957-000-284	S08M SCLPR/L2-281	0.500	6.000	0.281	0.560	CPMT 21.51	MTS-255	T-7
957-000-245	957-000-247	S06K SCLCR/L2-203	0.375	5.000	0.203	0.410	CCMT 21.51	MTS-255	T-7
957-000-275	957-000-278	S08M SCLCR/L2-281	0.500	6.000	0.281	0.560	CCMT 21.51	MTS-255	T-7

Minimum Clearance Bars are intended for light machining with minimum bore clearance. Max depth of cut .015" - .020"
*bars .312 and smaller do not have flats

PRODUCT #	Insert Screws
968-000-086	MTS-183
968-000-087	MTS-184
968-000-088	MTS-2
968-000-091	MTS-224
968-000-092	MTS-255
968-000-094	MTS-35
968-000-090	MTS-2.5L
968-000-052	ETS 4-40

PACKAGE SIZE OF 5

PRODUCT #	Key
968-000-156	T-6
968-000-158	T-7
968-000-149	T-10
968-000-151	T-15
968-000-153	T-20

PACKAGE SIZE OF 5

STEEL

ULTRA-DEX[®]

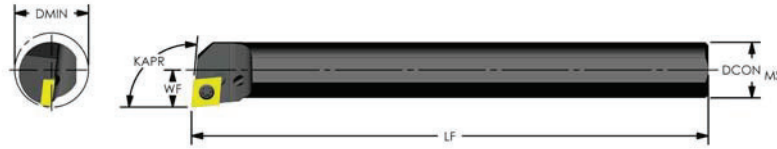

Positive 80° Diamond (KAPR: 95°)

4:1 Ratio
Coolant Thru

PRODUCT # Left hand	PRODUCT # Right hand	Designation	DCON MS	LF	WF	DMIN	Insert	Insert Screw	Key
957-000-001	957-000-003	A04G SCLDR/L1.5 *	0.250	3.500	0.172	0.312	CDGW 1.510	MTS-184	T-6
957-000-009	957-000-011	A05G SCLPR/L1.8 *	0.312	3.500	0.219	0.395	CPMT 1.81.20.5	MTS-224	T-7
957-000-023	957-000-025	A06K SCLPR/L2	0.375	5.000	0.250	0.460	CPMT 21.51	MTS-255	T-7
957-000-053	957-000-056	A08M SCLPR/L2	0.500	6.000	0.312	0.600	CPMT 21.51	MTS-255	T-7
957-000-087	957-000-089	A10Q SCLPR/L2	0.625	7.000	0.406	0.760	CPMT 21.51	MTS-255	T-7
957-000-055	957-000-058	A08M SCLPR/L3	0.500	6.000	0.344	0.625	CPMT 32.51	MTS-35	T-15
957-000-088	957-000-090	A10Q SCLPR/L3	0.625	7.000	0.406	0.760	CPMT 32.51	MTS-35	T-15
957-000-108	957-000-109	A12Q SCLPR/L3	0.750	7.000	0.500	0.920	CPMT 32.51	MTS-35	T-15
957-000-135	957-000-136	A16R SCLPR/L3	1.000	8.000	0.625	1.185	CPMT 32.51	MTS-35	T-15
957-000-019	957-000-021	A06K SCLCR/L2	0.375	5.000	0.250	0.460	CCMT 21.51	MTS-255	T-7
957-000-047	957-000-050	A08M SCLCR/L2	0.500	6.000	0.312	0.600	CCMT 21.51	MTS-255	T-7
957-000-083	957-000-085	A10Q SCLCR/L2	0.625	7.000	0.406	0.760	CCMT 21.51	MTS-255	T-7
957-000-049	957-000-052	A08M SCLCR/L3	0.500	6.000	0.344	0.625	CCMT 32.51	MTS-35	T-15
957-000-084	957-000-086	A10Q SCLCR/L3	0.625	7.000	0.406	0.760	CCMT 32.51	MTS-35	T-15
957-000-106	957-000-107	A12Q SCLCR/L3	0.750	7.000	0.500	0.920	CCMT 32.51	MTS-35	T-15
957-000-133	957-000-134	A16R SCLCR/L3	1.000	8.000	0.625	1.185	CCMT 32.51	MTS-35	T-15
957-000-182	957-000-184	A20U SCLCR/L3	1.250	14.000	0.765	1.465	CCMT 32.51	MTS-35	T-15
957-000-183	957-000-185	A20U SCLCR/L4	1.250	14.000	0.765	1.465	CCMT 432	MTS-4	T-20
957-000-198	957-000-199	A24U SCLCR/L4	1.500	14.000	0.890	1.730	CCMT 432	MTS-4	T-20

Minimum Clearance

Coolant Thru

PRODUCT # Left hand	PRODUCT # Right hand	Designation	DCON MS	LF	WF	DMIN	Insert	Insert Screw	Key
957-000-002	957-000-004	A04G SCLDR/L1.5-138 *	0.250	3.500	0.138	0.275	CDGW 1.510	MTS-184	T-6
957-000-010	957-000-012	A05G SCLPR/L1.8-167 *	0.312	3.500	0.167	0.340	CPMT 1.81.20.5	MTS-224	T-7
957-000-024	957-000-026	A06K SCLPR/L2-203	0.375	5.000	0.203	0.410	CPMT 21.51	MTS-255	T-7
957-000-054	957-000-057	A08M SCLPR/L2-281	0.500	6.000	0.281	0.560	CPMT 21.51	MTS-255	T-7
957-000-020	957-000-022	A06K SCLCR/L2-203	0.375	5.000	0.203	0.410	CCMT 21.51	MTS-255	T-7
957-000-048	957-000-051	A08M SCLCR/L2-281	0.500	6.000	0.281	0.560	CCMT 21.51	MTS-255	T-7

Minimum Clearance Bars are intended for light machining with minimum bore clearance. Max depth of cut .015" - .020"
*bars .312 and smaller do not have flats

PRODUCT #	Insert Screws
968-000-086	MTS-183
968-000-087	MTS-184
968-000-088	MTS-2
968-000-091	MTS-224
968-000-092	MTS-255
968-000-094	MTS-35
968-000-090	MTS-2.5L
968-000-052	ETS 4-40

PACKAGE SIZE OF 5

PRODUCT #	Key
968-000-156	T-6
968-000-158	T-7
968-000-149	T-10
968-000-151	T-15
968-000-153	T-20

PACKAGE SIZE OF 5

STEEL

ULTRA-DEX[®]

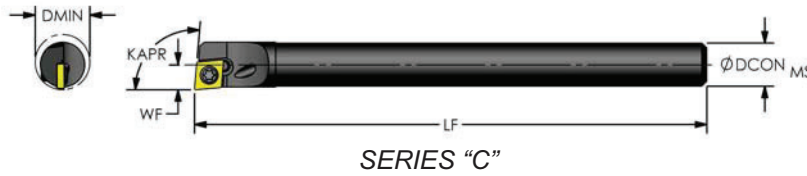

Positive 80° Diamond (KAPR: 95°)

4:1 Ratio
Coolant Thru

PRODUCT #	Designation	DCON MS	LF	WF	DMIN	KAPR	Insert	Insert Screw	Key
915-000-016	CSUD-180/187-2 1/2-5R *	0.187	2.500	0.104	0.208	95.0	CDHB 1.20.60.5	MTS-183	T-6
915-000-021	CSUD-187-2 1/2-5R *	0.187	2.500	0.116	0.230	95.0	CDHB 1.20.60.5	MTS-183	T-6
915-000-029	CSUD-250-3-5R *	0.250	3.000	0.145	0.285	95.0	CDHB 1.20.60.5	MTS-184	T-6

*bars do not have flats

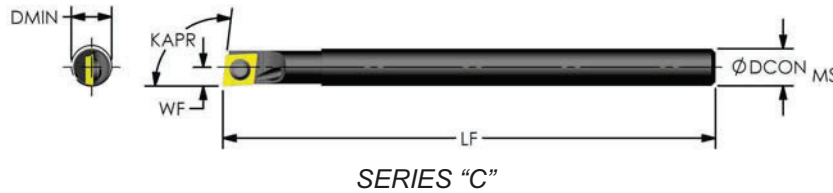

Positive 80° Diamond (KAPR: 97°)

4:1 Ratio
Coolant Thru

PRODUCT #	Designation	DCON MS	LF	WF	DMIN	KAPR	Insert	Insert Screw	Key
915-000-015	CSUD-165/187-2 1/2-7R *	0.187	2.500	0.095	0.180	97.0	CDHB 1.20.60.5	MTS-183	T-6

*bars do not have flats

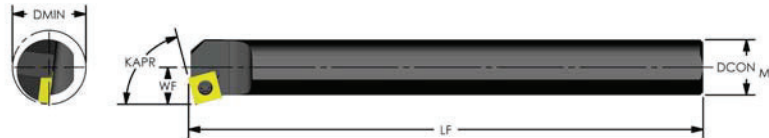

Positive 90° Square (KAPR: 75°)

4:1 Ratio
No Coolant

PRODUCT #	Designation	DCON MS	LF	WF	DMIN	KAPR	Insert	Insert Screw	Key
957-000-255	S06K SSKCR2	0.375	5.000	0.250	0.460	75.0	SCMT 21.51	MTS-255	T-7
957-000-292	S08M SSKCR3	0.500	6.000	0.344	0.625	75.0	SCMT 32.51	MTS-35	T-15
957-000-325	S10Q SSKCR3	0.625	7.000	0.406	0.760	75.0	SCMT 32.51	MTS-35	T-15
957-000-350	S12Q SSKCR3	0.750	7.000	0.500	0.920	75.0	SCMT 32.51	MTS-35	T-15
957-000-379	S16R SSKCR4	1.000	8.000	0.625	1.185	75.0	SCMT 432	MTS-4	T-20

PRODUCT #	Insert Screws
968-000-086	MTS-183
968-000-087	MTS-184
968-000-088	MTS-2
968-000-091	MTS-224
968-000-092	MTS-255
968-000-094	MTS-35
968-000-090	MTS-2.5L
968-000-052	ETS 4-40

PACKAGE SIZE OF 5

PRODUCT #	Key
968-000-156	T-6
968-000-158	T-7
968-000-149	T-10
968-000-151	T-15
968-000-153	T-20

PACKAGE SIZE OF 5

STEEL

ULTRA-DEX[®]

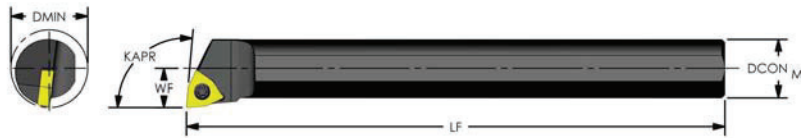

Positive Trigon (95° KAPR)

4:1 Ratio
No Coolant

PRODUCT # Left hand	PRODUCT # Right hand	Designation	DCON MS	LF	WF	DMIN	KAPR	Insert	Insert Screw	Key
N/A	957-000-213	S03G SWLCR1.2 *	0.187	3.500	0.102	0.205	95.0	WCMT 1.210.5	MTS-183	T-6
N/A	957-000-226	S04G SWLCR1.2 *	0.250	3.500	0.172	0.312	95.0	WCMT 1.210.5	MTS-184	T-6
N/A	957-000-240	S05G SWLCR1.5 *	0.312	3.500	0.219	0.395	95.0	WCMT 1.51.50.5	MTS-2	T-6
957-000-268	957-000-270	S06K SWLCR/L2	0.375	5.000	0.250	0.460	95.0	WCMT 21.51	MTS-255	T-7
957-000-305	957-000-307	S08M SWLCR/L2	0.500	6.000	0.312	0.600	95.0	WCMT 21.51	MTS-255	T-7
957-000-333	957-000-335	S10Q SWLCR/L2	0.625	7.000	0.406	0.760	95.0	WCMT 21.51	MTS-255	T-7
957-000-334	957-000-336	S10Q SWLCR/L3	0.625	7.000	0.406	0.760	95.0	WCMT 32.51	MTS-35	T-15
957-000-359	957-000-360	S12Q SWLCR/L3	0.750	7.000	0.500	0.920	95.0	WCMT 32.51	MTS-35	T-15
957-000-386	957-000-387	S16R SWLCR/L3	1.000	8.000	0.625	1.185	95.0	WCMT 32.51	MTS-35	T-15

Minimum Clearance

No Coolant

PRODUCT # Left hand	PRODUCT # Right hand	Designation	DCON MS	LF	WF	DMIN	KAPR	Insert	Insert Screw	Key
N/A	957-000-227	S04G SWLCR1.2-138 *	0.250	3.500	0.138	0.275	95.0	WCMT 1.210.5	MTS-184	T-6
N/A	957-000-241	S05G SWLCR1.5-167 *	0.312	3.500	0.167	0.342	95.0	WCMT 1.51.50.5	MTS-2	T-6
957-000-269	957-000-271	S06K SWLCR/L2-203	0.375	5.000	0.203	0.410	95.0	WCMT 21.51	MTS-255	T-7
957-000-306	957-000-308	S08M SWLCR/L2-281	0.500	6.000	0.281	0.560	95.0	WCMT 21.51	MTS-255	T-7

Minimum Clearance Bars are intended for light machining with minimum bore clearance. Max depth of cut .015" - .020"
*bars .312 and smaller do not have flats



Positive Trigon (95° KAPR)

4:1 Ratio
Coolant Thru

PRODUCT # Left hand	PRODUCT # Right hand	Designation	DCON MS	LF	WF	DMIN	KAPR	Insert	Insert Screw	Key
957-000-042	957-000-044	A06K SWLCR/L2	0.375	5.000	0.250	0.460	95.0	WCMT 21.51	MTS-255	T-7
957-000-076	957-000-078	A08M SWLCR/L2	0.500	6.000	0.312	0.600	95.0	WCMT 21.51	MTS-255	T-7
957-000-100	957-000-102	A10Q SWLCR/L2	0.625	7.000	0.406	0.760	95.0	WCMT 21.51	MTS-255	T-7
957-000-101	957-000-103	A10Q SWLCR/L3	0.625	7.000	0.406	0.760	95.0	WCMT 32.51	MTS-35	T-15
957-000-123	957-000-124	A12Q SWLCR/L3	0.750	7.000	0.500	0.920	95.0	WCMT 32.51	MTS-35	T-15
957-000-147	957-000-148	A16R SWLCR/L3	1.000	8.000	0.625	1.185	95.0	WCMT 32.51	MTS-35	T-15

Minimum Clearance

Coolant Thru

PRODUCT # Left hand	PRODUCT # Right hand	Designation	DCON MS	LF	WF	DMIN	KAPR	Insert	Insert Screw	Key
957-000-043	957-000-045	A06K SWLCR/L2-203	0.375	5.000	0.203	0.410	95.0	WCMT 21.51	MTS-255	T-7
957-000-077	957-000-079	A08M SWLCR/L2-281	0.500	6.000	0.281	0.560	95.0	WCMT 21.51	MTS-255	T-7

Minimum Clearance Bars are intended for light machining with minimum bore clearance. Max depth of cut .015" - .020"
*bars .312 and smaller do not have flats

PRODUCT #	Insert Screws
968-000-086	MTS-183
968-000-087	MTS-184
968-000-088	MTS-2
968-000-091	MTS-224
968-000-092	MTS-255
968-000-094	MTS-35
968-000-090	MTS-2.5L
968-000-052	ETS 4-40

PRODUCT #	Key
968-000-156	T-6
968-000-158	T-7
968-000-149	T-10
968-000-151	T-15
968-000-153	T-20

PACKAGE SIZE OF 5

PACKAGE SIZE OF 5

STEEL

ULTRA-DEX®

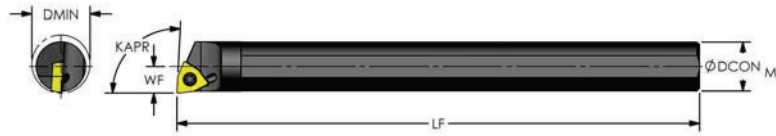

Positive Trigon (KAPR: 93°) SERIES "G, Q, S"

4:1 Ratio
Coolant Thru

PRODUCT # Left hand	PRODUCT # Right hand	Designation	DCON MS	LF	WF	DMIN	KAPR	Insert	Insert Screw	Key
915-000-059	915-000-060	GSUDW-187-4-3R/L	0.187	4.000	0.126	0.260	93.0	WPGT 1.511	MTS-184	T-6
915-000-061	915-000-062	GSUDW-250-4-3R/L	0.250	4.000	0.143	0.285	93.0	WPGT 1.511	MTS-184	T-6
915-000-063	915-000-064	GSUDW-312-4-3R/L	0.312	4.000	0.174	0.347	93.0	WPGT 1.511	MTS-184	T-6
915-000-082	915-000-083	QSUDW-375-5-3R/L	0.375	5.000	0.211	0.415	93.0	WPGT 21.50	MTS-255	T-7
915-000-084	915-000-085	QSUDW-500-6-3R/L	0.500	6.000	0.273	0.540	93.0	WPGT 21.50	MTS-255	T-7
915-000-101	915-000-102	SSUDW-625-7-3R/L	0.625	7.000	0.345	0.675	93.0	WPMT 32.51	MTS-35	T-15
915-000-103	915-000-104	SSUDW-750-8-3R/L	0.750	8.000	0.407	0.800	93.0	WPMT 32.51	MTS-35	T-15

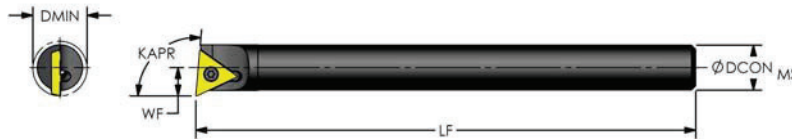

Positive Triangle (KAPR: 90°) SERIES "F, Q, S"

4:1 Ratio
Coolant Thru

PRODUCT #	Designation	DCON MS	LF	WF	DMIN	KAPR	Insert	Insert Screw	Key
915-000-047	FSUD-250-4-0R *	0.250	4.000	0.156	0.300	90.0	TDHB 1.280.750.5	MTS-224	T-7
915-000-077	QSUD-375-5-0R *	0.375	5.000	0.221	0.438	90.0	TPCB 220.5	ETS 4-40	T-10
915-000-094	SSUD-500-6-0R *	0.500	6.000	0.339	0.668	90.0	TD 320.5	ETS 4-40	T-10
915-000-097	SSUD-625-7-0R *	0.625	7.000	0.393	0.731	90.0	TD 320.5	ETS 4-40	T-10

* bars do not have flats



Positive Triangle (KAPR: 95°) SERIES "F, Q, S"

4:1 Ratio
Coolant Thru

PRODUCT # Left hand	PRODUCT # Right hand	Designation	DCON MS	LF	WF	DMIN	KAPR	Insert	Insert Screw	Key
N/A	915-000-040	FSUD-187-3 1/2-5R *	0.187	3.500	0.123	0.275	95.0	TDHB 1.280.750.5	MTS-224	T-7
N/A	915-000-048	FSUD-250-4-5R *	0.250	4.000	0.156	0.300	95.0	TDHB 1.280.750.5	MTS-224	T-7
N/A	915-000-052	FSUD-312-4-5R *	0.312	4.000	0.187	0.360	95.0	TDHB 1.280.750.5	MTS-224	T-7
915-000-078	915-000-079	QSUD-375-5-5R/L *	0.375	5.000	0.221	0.438	95.0	TPCB 220.5	ETS 4-40	T-10
N/A	915-000-080	QSUD-500-6-5R *	0.500	6.000	0.296	0.563	95.0	TPCB 220.5	ETS 4-40	T-10
N/A	915-000-095	SSUD-500-6-5R *	0.500	6.000	0.339	0.668	95.0	TD 320.5	ETS 4-40	T-10
N/A	915-000-096	SSUD-625-4-5R *	0.625	4.000	0.393	0.731	95.0	TD 320.5	ETS 4-40	T-10
N/A	915-000-098	SSUD-625-7-5R *	0.625	7.000	0.393	0.731	95.0	TD 320.5	ETS 4-40	T-10
N/A	915-000-099	SSUD-750-4-5R *	0.750	4.000	0.460	0.855	95.0	TD 320.5	ETS 4-40	T-10
N/A	915-000-100	SSUD-750-8-5R *	0.750	8.000	0.460	0.855	95.0	TD 320.5	ETS 4-40	T-10
N/A	915-000-092	SSUD-1000-10-5R *	1.000	10.000	0.585	1.105	95.0	TD 320.5	ETS 4-40	T-10
N/A	915-000-093	SSUD-1250-12-5R *	1.250	12.000	0.710	1.355	95.0	TD 320.5	ETS 4-40	T-10

* bars do not have flats

STEEL

ULTRA-DEX[®]

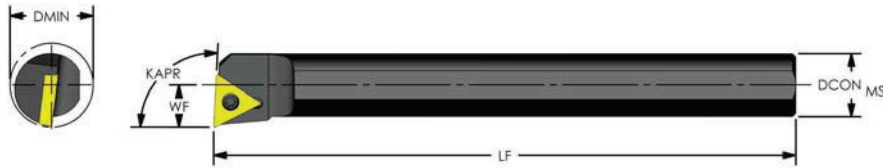

Positive Triangle (KAPR: 93°)

4:1 Ratio
No Coolant

PRODUCT # Left hand	PRODUCT # Right hand	Designation	DCON MS	LF	WF	DMIN	KAPR	Insert	Insert Screw	Key
957-000-222	957-000-224	S04G STUCR/L1.2 *	0.250	3.500	0.172	0.312	93.0	TCMT 1.21.20.5	MTS-184	T-6
957-000-236	957-000-238	S05G STUCR/L1.2 *	0.312	3.500	0.219	0.395	93.0	TCMT 1.21.20.5	MTS-184	T-6
957-000-260	957-000-262	S06K STUCR/L2	0.375	5.000	0.250	0.460	93.0	TCMT 21.51	MTS-255	T-7
957-000-297	957-000-299	S08M STUCR/L2	0.500	6.000	0.312	0.600	93.0	TCMT 21.51	MTS-255	T-7
957-000-328	957-000-329	S10Q STUCR/L2	0.625	7.000	0.406	0.760	93.0	TCMT 21.51	MTS-255	T-7
957-000-353	957-000-354	S12Q STUCR/L3	0.750	7.000	0.500	0.920	93.0	TCMT 32.51	MTS-35	T-15
957-000-382	957-000-383	S16R STUCR/L3	1.000	8.000	0.625	1.185	93.0	TCMT 32.51	MTS-35	T-15
957-000-266	957-000-264	S06K STUPR/L2	0.375	5.000	0.250	0.460	93.0	TPMT 21.51	MTS-255	T-7
957-000-301	957-000-303	S08M STUPR/L2	0.500	6.000	0.312	0.600	93.0	TPMT 21.51	MTS-255	T-7
957-000-330	957-000-331	S10Q STUPR/L2	0.625	7.000	0.406	0.760	93.0	TPMT 21.51	MTS-255	T-7
957-000-355	957-000-356	S12Q STUPR/L3	0.750	7.000	0.500	0.920	93.0	TPMT 32.51	MTS-35	T-15
957-000-384	957-000-385	S16R STUPR/L3	1.000	8.000	0.625	1.185	93.0	TPMT 32.51	MTS-35	T-15

Minimum Clearance

No Coolant

PRODUCT # Left hand	PRODUCT # Right hand	Designation	DCON MS	LF	WF	DMIN	KAPR	Insert	Insert Screw	Key
957-000-223	957-000-225	S04G STUCR/L1.2-138 *	0.250	3.500	0.138	0.275	93.0	TCMT 1.21.20.5	MTS-184	T-6
957-000-237	957-000-239	S05G STUCR/L1.2-167 *	0.312	3.500	0.167	0.340	93.0	TCMT 1.21.20.5	MTS-184	T-6
957-000-261	957-000-263	S06K STUCR/L2-203	0.375	5.000	0.203	0.410	93.0	TCMT 21.51	MTS-255	T-7
957-000-298	957-000-300	S08M STUCR/L2-281	0.500	6.000	0.281	0.560	93.0	TCMT 21.51	MTS-255	T-7
957-000-265	957-000-267	S06K STUPR/L2-203	0.375	5.000	0.203	0.410	93.0	TPMT 21.51	MTS-255	T-7
957-000-302	957-000-304	S08M STUPR/L2-281	0.500	6.000	0.281	0.560	93.0	TPMT 21.51	MTS-255	T-7

Minimum Clearance Bars are intended for light machining with minimum bore clearance. Max depth of cut .015" - .020"
*bars .312 and smaller do not have flats

PRODUCT #	Insert Screws
968-000-086	MTS-183
968-000-087	MTS-184
968-000-088	MTS-2
968-000-091	MTS-224
968-000-092	MTS-255
968-000-094	MTS-35
968-000-090	MTS-2.5L
968-000-052	ETS 4-40

PACKAGE SIZE OF 5

PRODUCT #	Key
968-000-156	T-6
968-000-158	T-7
968-000-149	T-10
968-000-151	T-15
968-000-153	T-20

PACKAGE SIZE OF 5

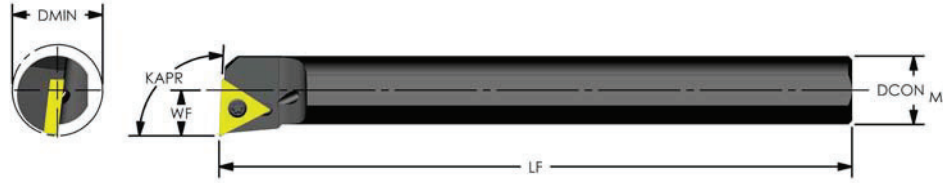

Positive Triangle (KAPR: 93°)

4:1 Ratio
Coolant Thru

PRODUCT # Left hand	PRODUCT # Right hand	Designation	DCON MS	LF	WF	DMIN	KAPR	Insert	Insert Screw	Key
957-000-005	957-000-007	A04G STUCR/L1.2 *	0.250	3.500	0.172	0.312	93.0	TCMT 1.21.20.5	MTS-184	T-6
957-000-013	957-000-015	A05G STUCR/L1.2 *	0.312	3.500	0.219	0.395	93.0	TCMT 1.21.20.5	MTS-184	T-6
957-000-033	957-000-035	A06K STUCR/L2	0.375	5.000	0.250	0.460	93.0	TCMT 21.51	MTS-255	T-7
957-000-067	957-000-069	A08M STUCR/L2	0.500	6.000	0.312	0.600	93.0	TCMT 21.51	MTS-255	T-7
957-000-097	957-000-096	A10Q STUCR/L2	0.625	7.000	0.406	0.760	93.0	TCMT 21.51	MTS-255	T-7
957-000-120	957-000-119	A12Q STUCR/L3	0.750	7.000	0.500	0.920	93.0	TCMT 32.51	MTS-35	T-15
957-000-143	957-000-144	A16R STUCR/L3	1.000	8.000	0.625	1.185	93.0	TCMT 32.51	MTS-35	T-15
957-000-037	957-000-039	A06K STUPR/L2	0.375	5.000	0.250	0.460	93.0	TPMT 21.51	MTS-255	T-7
957-000-071	957-000-073	A08M STUPR/L2	0.500	6.000	0.312	0.600	93.0	TPMT 21.51	MTS-255	T-7
957-000-097	957-000-098	A10Q STUPR/L2	0.625	7.000	0.406	0.760	93.0	TPMT 21.51	MTS-255	T-7
957-000-119	957-000-120	A12Q STUPR/L3	0.750	7.000	0.500	0.920	93.0	TPMT 32.51	MTS-35	T-15
957-000-145	957-000-146	A16R STUPR/L3	1.000	8.000	0.625	1.185	93.0	TPMT 32.51	MTS-35	T-15

Minimum Clearance

Coolant Thru

PRODUCT # Left hand	PRODUCT # Right hand	Designation	DCON MS	LF	WF	DMIN	KAPR	Insert	Insert Screw	Key
957-000-006	957-000-008	A04G STUCR/L1.2-138 *	0.250	3.500	0.138	0.275	93.0	TCMT 1.21.20.5	MTS-184	T-6
957-000-014	957-000-016	A05G STUCR/L1.2-167 *	0.312	3.500	0.167	0.340	93.0	TCMT 1.21.20.5	MTS-184	T-6
957-000-034	957-000-036	A06K STUCR/L2-203	0.375	5.000	0.203	0.410	93.0	TCMT 21.51	MTS-255	T-7
957-000-068	957-000-070	A08M STUCR/L2-281	0.500	6.000	0.281	0.560	93.0	TCMT 21.51	MTS-255	T-7
957-000-038	957-000-040	A06K STUPR/L2-203	0.375	5.000	0.203	0.410	93.0	TPMT 21.51	MTS-255	T-7
957-000-072	957-000-074	A08M STUPR/L2-281	0.500	6.000	0.281	0.560	93.0	TPMT 21.51	MTS-255	T-7

Minimum Clearance Bars are intended for light machining with minimum bore clearance. Max depth of cut .015" - .020"
*bars .312 and smaller do not have flats

PRODUCT #	Insert Screws
968-000-086	MTS-183
968-000-087	MTS-184
968-000-088	MTS-2
968-000-091	MTS-224
968-000-092	MTS-255
968-000-094	MTS-35
968-000-090	MTS-2.5L
968-000-052	ETS 4-40

PACKAGE SIZE OF 5

PRODUCT #	Key
968-000-156	T-6
968-000-158	T-7
968-000-149	T-10
968-000-151	T-15
968-000-153	T-20

PACKAGE SIZE OF 5

ULTRA-DEX[®]

STEEL

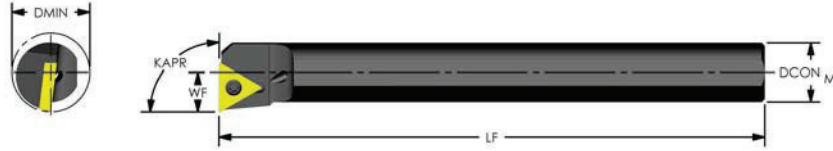

Positive Triangle (KAPR: 90°)

4:1 Ratio
No Coolant

PRODUCT # Left hand	PRODUCT # Right hand	Designation	DCON MS	LF	WF	DMIN	KAPR	Insert	Insert Screw	Key
957-000-218	957-000-220	S04G STFCR/L1.2 *	0.250	3.500	0.172	0.312	90.0	TCMT 1.21.20.5	MTS-184	T-6
957-000-232	957-000-234	S05G STFCR/L1.2 *	0.312	3.500	0.219	0.395	90.0	TCMT 1.21.20.5	MTS-184	T-6
N/A	957-000-256	S06K STFCR2	0.375	5.000	0.250	0.460	90.0	TCMT 21.51	MTS-255	T-7
N/A	957-000-293	S08M STFCR2	0.500	6.000	0.312	0.600	90.0	TCMT 21.51	MTS-255	T-7
N/A	957-000-326	S10Q STFCR2	0.625	7.000	0.406	0.760	90.0	TCMT 21.51	MTS-255	T-7
N/A	957-000-351	S12Q STFCR3	0.750	7.000	0.500	0.920	90.0	TCMT 32.51	MTS-35	T-15
N/A	957-000-380	S16R STFCR3	1.000	8.000	0.625	1.185	90.0	TCMT 32.51	MTS-35	T-15
N/A	957-000-258	S06K STFPR2	0.375	5.000	0.250	0.460	90.0	TPMT 21.51	MTS-255	T-7
N/A	957-000-295	S08M STFPR2	0.500	6.000	0.312	0.600	90.0	TPMT 21.51	MTS-255	T-7
N/A	957-000-327	S10Q STFPR2	0.625	7.000	0.406	0.760	90.0	TPMT 21.51	MTS-255	T-7
N/A	957-000-352	S12Q STFPR3	0.750	7.000	0.500	0.920	90.0	TPMT 32.51	MTS-35	T-15
N/A	957-000-381	S16R STFPR3	1.000	8.000	0.625	1.185	90.0	TPMT 32.51	MTS-35	T-15

Minimum Clearance

No Coolant

PRODUCT # Left hand	PRODUCT # Right hand	Designation	DCON MS	LF	WF	DMIN	KAPR	Insert	Insert Screw	Key
957-000-219	957-000-221	S04G STFCR/L1.2-138 *	0.250	3.500	0.138	0.275	90.0	TCMT 1.21.20.5	MTS-184	T-6
957-000-233	957-000-235	S05G STFCR/L1.2-167 *	0.312	3.500	0.167	0.340	90.0	TCMT 1.21.20.5	MTS-184	T-6
N/A	957-000-257	S06K STFCR2-203	0.375	5.000	0.203	0.410	90.0	TCMT 21.51	MTS-255	T-7
N/A	957-000-294	S08M STFCR2-281	0.500	6.000	0.281	0.560	90.0	TCMT 21.51	MTS-255	T-7
N/A	957-000-259	S06K STFPR2-203	0.375	5.000	0.203	0.410	90.0	TPMT 21.51	MTS-255	T-7
N/A	957-000-296	S08M STFPR2-281	0.500	6.000	0.281	0.560	90.0	TPMT 21.51	MTS-255	T-7

Minimum Clearance Bars are intended for light machining with minimum bore clearance. Max depth of cut .015" - .020"
*bars .312 and smaller do not have flats

PRODUCT #	Insert Screws
968-000-086	MTS-183
968-000-087	MTS-184
968-000-088	MTS-2
968-000-091	MTS-224
968-000-092	MTS-255
968-000-094	MTS-35
968-000-090	MTS-2.5L
968-000-052	ETS 4-40

PACKAGE SIZE OF 5

PRODUCT #	Key
968-000-156	T-6
968-000-158	T-7
968-000-149	T-10
968-000-151	T-15
968-000-153	T-20

PACKAGE SIZE OF 5

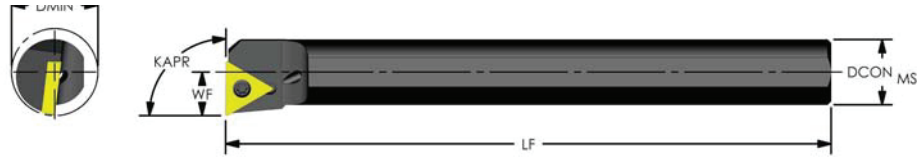

Positive Triangle (KAPR: 90°)

4:1 Ratio
Coolant Thru

PRODUCT #	Designation	DCON MS	LF	WF	DMIN	KAPR	Insert	Insert Screw	Key
957-000-029	A06K STFCR2	0.375	5.000	0.250	0.460	90.0	TCMT 21.51	MTS-255	T-7
957-000-063	A08M STFCR2	0.500	6.000	0.312	0.600	90.0	TCMT 21.51	MTS-255	T-7
957-000-093	A10Q STFCR2	0.625	7.000	0.406	0.760	90.0	TCMT 21.51	MTS-255	T-7
957-000-116	A12Q STFCR3	0.750	7.000	0.500	0.920	90.0	TCMT 32.51	MTS-35	T-15
957-000-141	A16R STFCR3	1.000	8.000	0.625	1.185	90.0	TCMT 32.51	MTS-35	T-15
957-000-031	A06K STFPR2	0.375	5.000	0.250	0.460	90.0	TPMT 21.51	MTS-255	T-7
957-000-063	A08M STFPR2	0.500	6.000	0.312	0.600	90.0	TPMT 21.51	MTS-255	T-7
957-000-094	A10Q STFPR2	0.625	7.000	0.406	0.760	90.0	TPMT 21.51	MTS-255	T-7
957-000-117	A12Q STFPR3	0.750	7.000	0.500	0.920	90.0	TPMT 32.51	MTS-35	T-15
957-000-142	A16R STFPR3	1.000	8.000	0.625	1.185	90.0	TPMT 32.51	MTS-35	T-15

Minimum Clearance

Coolant Thru

PRODUCT #	Designation	DCON MS	LF	WF	DMIN	KAPR	Insert	Insert Screw	Key
957-000-030	A06K STFCR2-203	0.375	5.000	0.203	0.410	90.0	TCMT 21.51	MTS-255	T-7
957-000-064	A08M STFCR2-281	0.500	6.000	0.281	0.560	90.0	TCMT 21.51	MTS-255	T-7
957-000-032	A06K STFPR2-203	0.375	5.000	0.203	0.410	90.0	TPMT 21.51	MTS-255	T-7
957-000-066	A08M STFPR2-281	0.500	6.000	0.281	0.560	90.0	TPMT 21.51	MTS-255	T-7

Minimum Clearance Bars are intended for light machining with minimum bore clearance. Max depth of cut .015" - .020"
*bars .312 and smaller do not have flats

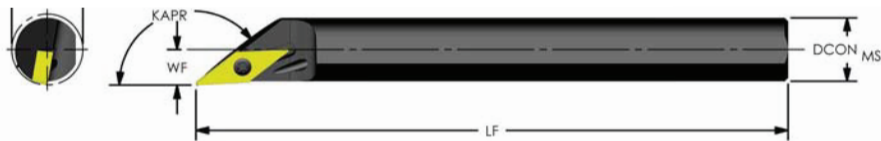

Positive 35° Diamond (KAPR: 142°) Profiling

4:1 Ratio
Coolant Thru

PRODUCT #	Designation	DCON MS	LF	WF	DMIN	KAPR	Insert	Insert Screw	Key
957-000-041	A06K SVJBR2	0.375	5.000	0.223	0.445	142.0	VBMT 21.51	MTS-2.5L	T-7
957-000-075	A08M SVJBR2	0.500	6.000	0.285	0.570	142.0	VBMT 21.51	MTS-2.5L	T-7
957-000-099	A10Q SVJBR2	0.625	7.000	0.348	0.700	142.0	VBMT 21.51	MTS-2.5L	T-7
957-000-122	A12Q SVJBR3	0.750	7.000	0.421	0.840	142.0	VBMT 331	MTS-3.5L	T-15

ULTRA-DEX[®]

STEEL



Positive 55° Diamond (KAPR: 93°) Profiling

4:1 Ratio
No Coolant

PRODUCT # Left hand	PRODUCT # Right hand	Designation	DCON MS	LF	WF	DMIN	KAPR	Insert	Insert Screw	Key
957-000-253	957-000-254	S06K SDUCR/L2	0.375	5.000	0.375	0.585	93.0	DCMT 21.51	MTS-255	T-7
957-000-288	957-000-289	S08M SDUCR/L2	0.500	6.000	0.437	0.720	93.0	DCMT 21.51	MTS-255	T-7
957-000-323	957-000-324	S10Q SDUCR/L2	0.625	7.000	0.500	0.850	93.0	DCMT 21.51	MTS-255	T-7
957-000-344	957-000-345	S12Q SDUCR/L3	0.750	7.000	0.625	1.050	93.0	DCMT 32.51	MTS-35	T-15
957-000-376	957-000-375	S16R SDUCR/L3	1.000	8.000	0.750	1.310	93.0	DCMT 32.51	MTS-35	T-15
957-000-346	957-000-347	S12Q SDUPR/L3	0.750	7.000	0.625	1.050	93.0	DPMT 32.51	MTS-35	T-15
957-000-377	957-000-378	S16R SDUPR/L3	1.000	8.000	0.750	1.310	93.0	DPMT 32.51	MTS-35	T-15



Positive 55° Diamond (KAPR: 93°) Profiling

Coolant Thru

PRODUCT # Left hand	PRODUCT # Right hand	Designation	DCON MS	LF	WF	DMIN	KAPR	Insert	Insert Screw	Key
957-000-027	957-000-028	A06K SDUCR/L2	0.375	5.000	0.375	0.585	93.0	DCMT 21.51	MTS-255	T-7
957-000-059	957-000-060	A08M SDUCR/L2	0.500	6.000	0.437	0.720	93.0	DCMT 21.51	MTS-255	T-7
957-000-091	957-000-092	A10Q SDUCR/L2	0.625	7.000	0.500	0.850	93.0	DCMT 21.51	MTS-255	T-7
957-000-110	957-000-111	A12Q SDUCR/L3	0.750	7.000	0.625	1.050	93.0	DCMT 32.51	MTS-35	T-15
957-000-137	957-000-138	A16R SDUCR/L3	1.000	8.000	0.750	1.310	93.0	DCMT 32.51	MTS-35	T-15
957-000-112	957-000-113	A12Q SDUPR/L3	0.750	7.000	0.625	1.050	93.0	DPMT 32.51	MTS-35	T-15
957-000-139	957-000-140	A16R SDUPR/L3	1.000	8.000	0.750	1.310	93.0	DPMT 32.51	MTS-35	T-15

PRODUCT #	Insert Screws
968-000-086	MTS-183
968-000-087	MTS-184
968-000-088	MTS-2
968-000-091	MTS-224
968-000-092	MTS-255
968-000-094	MTS-35
968-000-090	MTS-2.5L
968-000-052	ETS 4-40

PACKAGE SIZE OF 5

PRODUCT #	Key
968-000-156	T-6
968-000-158	T-7
968-000-149	T-10
968-000-151	T-15
968-000-153	T-20

PACKAGE SIZE OF 5

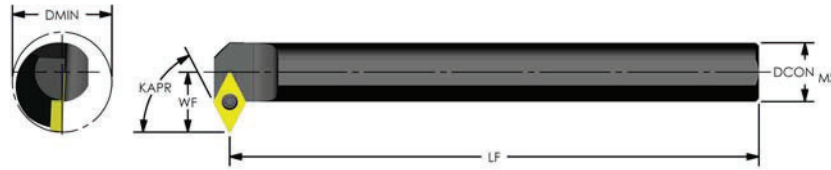

Positive 55° Diamond (KAPR: 62.5°) Profiling

4:1 Ratio
No Coolant

PRODUCT #	Designation	DCON MS	LF	WF	DMIN	KAPR	Insert	Insert Screw	Key
957-000-286	S08M SDNCR2	0.500	6.000	0.508	0.780	62.5	DCMT 21.51	MTS-255	T-7
957-000-321	S10Q SDNCR2	0.625	6.860	0.562	0.920	62.5	DCMT 21.51	MTS-255	T-7
957-000-343	S12Q SDNCR3	0.750	6.800	0.765	1.190	62.5	DCMT 32.51	MTS-35	T-15
957-000-374	S16R SDNCR3	1.000	7.800	0.890	1.450	62.5	DCMT 32.51	MTS-35	T-15

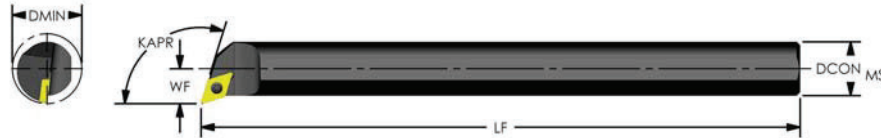

Positive 55° Diamond (KAPR: 107.5°) Profiling

4:1 Ratio
No Coolant

PRODUCT #	Designation	DCON MS	LF	WF	DMIN	KAPR	Insert	Insert Screw	Key
957-000-252	S06K SDQCR2	0.375	5.000	0.281	0.490	107.5	DCMT 21.51	MTS-255	T-7
957-000-287	S08M SDQCR2	0.500	6.000	0.341	0.620	107.5	DCMT 21.51	MTS-255	T-7
957-000-322	S10Q SDQCR2	0.625	7.000	0.406	0.760	107.5	DCMT 21.51	MTS-255	T-7

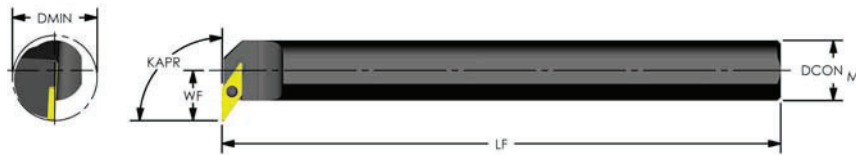

Positive 35° Diamond (KAPR: 90°) Profiling

4:1 Ratio
No Coolant

PRODUCT #	Designation	DCON MS	LF	WF	DMIN	KAPR	Insert	Insert Screw	Key
957-000-332	S10Q SVFBR2	0.625	7.000	0.500	0.850	90.0	VBMT 21.51	MTS-2.5L	T-7
957-000-357	S12Q SVFBR2	0.750	7.000	0.625	1.050	90.0	VBMT 21.51	MTS-2.5L	T-7
957-000-404	S16X SVFBR3	1.000	9.000	0.750	1.310	90.0	VBMT 331	MTS-3.5L	T-15

PRODUCT #	Insert Screws
968-000-086	MTS-183
968-000-087	MTS-184
968-000-088	MTS-2
968-000-091	MTS-224
968-000-092	MTS-255
968-000-094	MTS-35
968-000-090	MTS-2.5L
968-000-052	ETS 4-40

PACKAGE SIZE OF 5

PRODUCT #	Key
968-000-156	T-6
968-000-158	T-7
968-000-149	T-10
968-000-151	T-15
968-000-153	T-20

PACKAGE SIZE OF 5

ULTRA-DEX[®]

STEEL

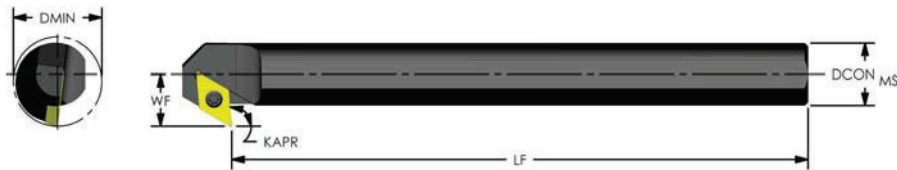

Positive 55° Diamond (KAPR: 95°) Back Facing

4:1 Ratio
No Coolant

PRODUCT # Left hand	PRODUCT # Right hand	Designation	DCON MS	LF	WF	DMIN	KAPR	Insert	Insert Screw	Key
957-000-242	957-000-243	S06J SDXCR/L2	0.375	4.500	0.375	0.585	95.0	DCMT 21.51	MTS-255	T-7
957-000-290	957-000-291	S08M SDXCR/L2	0.500	6.000	0.437	0.720	95.0	DCMT 21.51	MTS-255	T-7
957-000-309	957-000-310	S10M SDXCR/L2	0.625	6.000	0.500	0.850	95.0	DCMT 21.51	MTS-255	T-7
957-000-348	957-000-349	S12Q SDXCR/L3	0.750	7.000	0.625	1.050	95.0	DCMT 32.51	MTS-35	T-15
957-000-402	957-000-403	S16X SDXCR/L3	1.000	9.000	0.750	1.310	95.0	DCMT 32.51	MTS-35	T-15

Coolant Thru

PRODUCT # Left hand	PRODUCT # Right hand	Designation	DCON MS	LF	WF	DMIN	KAPR	Insert	Insert Screw	Key
957-000-017	957-000-018	A06J SDXCR/L2	0.375	4.500	0.375	0.585	95.0	DCMT 21.51	MTS-255	T-7
957-000-061	957-000-062	A08M SDXCR/L2	0.500	6.000	0.437	0.720	95.0	DCMT 21.51	MTS-255	T-7
957-000-080	957-000-081	A10M SDXCR/L2	0.625	6.000	0.500	0.850	95.0	DCMT 21.51	MTS-255	T-7
957-000-114	957-000-115	A12Q SDXCR/L3	0.750	7.000	0.625	1.050	95.0	DCMT 32.51	MTS-35	T-15
957-000-162	957-000-163	A16X SDXCR/L3	1.000	9.000	0.750	1.310	95.0	DCMT 32.51	MTS-35	T-15

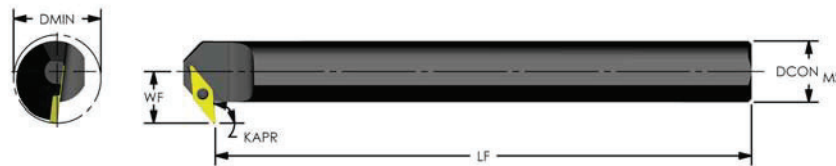

Positive 35° Diamond (KAPR: 95°) Back Facing

4:1 Ratio
No Coolant

PRODUCT #	Designation	DCON MS	LF	WF	DMIN	KAPR	Insert	Insert Screw	Key
957-000-358	S12Q SVXBR2	0.750	6.600	0.625	1.050	95.0	VBMT 21.51	MTS-2.5L	T-7
957-000-405	S16X SVXBR3	1.000	9.000	0.875	1.435	95.0	VBMT 331	MTS-3.5L	T-15

PRODUCT #	Insert Screws
968-000-086	MTS-183
968-000-087	MTS-184
968-000-088	MTS-2
968-000-091	MTS-224
968-000-092	MTS-255
968-000-094	MTS-35
968-000-090	MTS-2.5L
968-000-052	ETS 4-40

PACKAGE SIZE OF 5

PRODUCT #	Key
968-000-156	T-6
968-000-158	T-7
968-000-149	T-10
968-000-151	T-15
968-000-153	T-20

PACKAGE SIZE OF 5

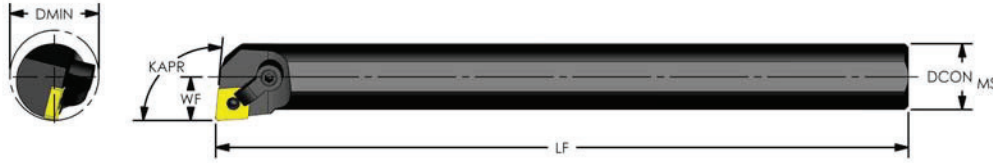

Negative 80° Diamond (KAPR: 95°)

**4:1 Ratio
No Coolant**

PRODUCT # Left hand	PRODUCT # Right hand	Designation	DCON MS	LF	WF	DMIN	KAPR	Insert	Shim Seat	Clamp	Clamp Screw	Lock Pin
957-000-361	957-000-362	S12R MCLNR/L3	0.750	8.000	0.500	0.920	95.0	CNMG 322	N/A	CL-7	XNS-36	NL-33
957-000-388	957-000-390	S16S MCLNR/L3	1.000	10.000	0.640	1.200	95.0	CNMG 322	N/A	CL-7	XNS-36	NL-33
957-000-389	957-000-391	S16S MCLNR/L4	1.000	10.000	0.640	1.200	95.0	CNMG 432	N/A	CL-20	XNS-47	NL-44
957-000-406	957-000-407	S20S MCLNR/L4	1.250	10.000	0.765	1.470	95.0	CNMG 432	ICSN-433	CL-20	XNS-47	NL-46
957-000-419	957-000-420	S20U MCLNR/L4	1.250	14.000	0.765	1.470	95.0	CNMG 432	ICSN-433	CL-20	XNS-47	NL-46
957-000-429	957-000-430	S24U MCLNR/L4	1.500	14.000	.890	1.730	95.0	CNMG 432	ICSN-433	CL-20	XNS-47	NL-46
957-000-442	957-000-443	S32V MCLNR/L4	2.000	16.000	1.281	2.400	95.0	CNMG 432	ICSN-433	CL-20	XNS-47	NL-46

Coolant Thru

PRODUCT # Left hand	PRODUCT # Right hand	Designation	DCON MS	LF	WF	DMIN	KAPR	Insert	Shim Seat	Clamp	Clamp Screw	Lock Pin
957-000-125	957-000-126	A12R MCLNR/L3	0.750	8.000	0.500	0.920	95.0	CNMG 322	N/A	CL-7	XNS-36	NL-33
957-000-151	957-000-153	A16S MCLNR/L3	1.000	10.000	0.640	1.200	95.0	CNMG 322	N/A	CL-7	XNS-36	NL-33
957-000-152	957-000-154	A16S MCLNR/L4	1.000	10.000	0.640	1.200	95.0	CNMG 432	N/A	CL-20	XNS-47	NL-44
957-000-164	957-000-165	A20S MCLNR/L4	1.250	10.000	0.765	1.470	95.0	CNMG 432	ICSN-433	CL-20	XNS-47	NL-46
957-000-178	957-000-179	A20U MCLNR/L4	1.250	14.000	0.765	1.470	95.0	CNMG 432	ICSN-433	CL-20	XNS-47	NL-46
957-000-189	957-000-190	A24U MCLNR/L4	1.500	14.000	0.890	1.730	95.0	CNMG 432	ICSN-433	CL-20	XNS-47	NL-46
957-000-200	957-000-201	A32V MCLNR/L4	2.000	16.000	1.281	2.400	95.0	CNMG 432	ICSN-433	CL-20	XNS-47	NL-46

PRODUCT #	Shim Seat
968-000-053	ICSN-433
968-000-054	ICSN-533
968-000-055	ICSN-633
968-000-063	ISSN-432
968-000-064	ISSN-433
968-000-065	ISSN-533
968-000-066	ISSN-633
968-000-056	IDSN-322
968-000-057	IDSN-433
968-000-058	IDSN-533
968-000-067	ITSN-323
968-000-068	ITSN-433

PACKAGE SIZE OF 10

PRODUCT #	Shim Seat
968-000-069	ITSN-533
968-000-070	ITSN-636
968-000-071	IVSN-322
968-000-072	IVSN-432
968-000-073	IVSN-433
968-000-074	IWSN-322
968-000-075	IWSN-433
968-000-059	IRSN-32
968-000-060	IRSN-43
968-000-061	IRSN-53
968-000-062	IRSN-63

PACKAGE SIZE OF 10

PRODUCT #	Lock Pin
968-000-097	NL-33
968-000-098	NL-33L
968-000-099	NL-34
968-000-100	NL-34L
968-000-101	NL-44
968-000-102	NL-46
968-000-103	NL-56
968-000-104	NL-58
968-000-105	NL-68
968-000-106	NL-68L

PACKAGE SIZE OF 5

ULTRA-DEX[®]

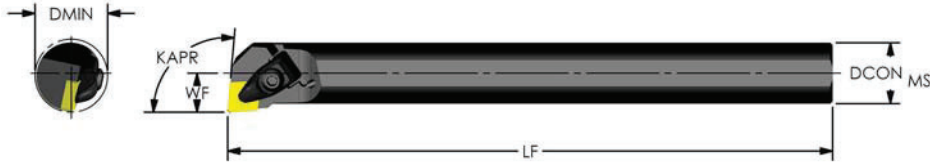

Negative 80° Diamond (KAPR: 95°)

4:1 Ratio
Coolant Thru

PRODUCT #	Designation	DCON MS	LF	WF	DMIN	Insert	Shim	Shim Screw	Clamp Assy.
957-000-149	A16S DCLNR4	1.000	10.000	0.640	1.200	CNMG 432	N/A	N/A	PB4-CA
957-000-176	A20U DCLNR4	1.250	14.000	0.765	1.470	CNMG 432	ICSN 433	PB4-SS	PB4-CA
957-000-186	A24U DCLNR4	1.500	14.000	0.890	1.730	CNMG 432	ICSN 433	PB4-SS	PB4-CA

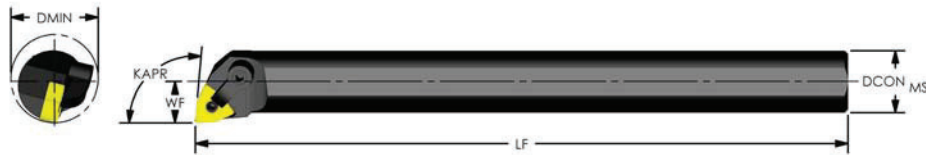

Negative Trigon (KAPR: 95°)

4:1 Ratio
No Coolant

PRODUCT # Left hand	PRODUCT # Right hand	Designation	DCON MS	LF	WF	DMIN	KAPR	Insert	Shim Seat	Clamp	Clamp Screw	Lock Pin
957-000-365	957-000-366	S12R MWLNR/L3	0.750	8.000	0.500	0.920	95.0	WNMG 332	N/A	CL-7	XNS-36	NL-33L
957-000-397	957-000-399	S16S MWLNR/L3	1.000	10.000	0.640	1.200	95.0	WNMG 332	N/A	CL-7	XNS-36	NL-33L
957-000-398	957-000-400	S16S MWLNR/L4	1.000	10.000	0.640	1.200	95.0	WNMG 432	N/A	CL-20	XNS-47	NL-44
957-000-410	957-000-411	S20S MWLNR/L4	1.250	10.000	0.765	1.470	95.0	WNMG 432	IWSN-433	CL-20	XNS-47	NL-46
957-000-423	957-000-424	S20U MWLNR/L4	1.250	14.000	0.765	1.470	95.0	WNMG 432	IWSN-433	CL-20	XNS-47	NL-46
957-000-438	957-000-439	S24U MWLNR/L4	1.500	14.000	0.890	1.730	95.0	WNMG 432	IWSN-433	CL-20	XNS-47	NL-46
957-000-444	957-000-445	S32V MWLNR/L4	2.000	16.000	1.281	2.400	95.0	WNMG 432	IWSN-433	CL-20	XNS-47	NL-46

Coolant Thru

PRODUCT # Left hand	PRODUCT # Right hand	Designation	DCON MS	LF	WF	DMIN	KAPR	Insert	Shim Seat	Clamp	Clamp Screw	Lock Pin
957-000-129	957-000-130	A12R MWLNR/L3	0.750	8.000	0.500	0.920	95.0	WNMG 332	N/A	CL-7	XNS-36	NL-33L
957-000-158	957-000-160	A16S MWLNR/L3	1.000	10.000	0.640	1.200	95.0	WNMG 332	N/A	CL-7	XNS-36	NL-33L
957-000-159	957-000-161	A16S MWLNR/L4	1.000	10.000	0.640	1.200	95.0	WNMG 432	N/A	CL-20	XNS-47	NL-44
957-000-166	957-000-167	A20S MWLNR/L4	1.250	10.000	0.765	1.470	95.0	WNMG 432	IWSN-433	CL-20	XNS-47	NL-46
957-000-180	957-000-181	A20U MWLNR/L4	1.250	14.000	0.765	1.470	95.0	WNMG 432	IWSN-433	CL-20	XNS-47	NL-46
957-000-196	957-000-197	A24U MWLNR/L4	1.500	14.000	0.890	1.730	95.0	WNMG 432	IWSN-433	CL-20	XNS-47	NL-46
957-000-202	957-000-203	A32V MWLNR/L4	2.000	16.000	1.281	2.400	95.0	WNMG 432	IWSN-433	CL-20	XNS-47	NL-46

PRODUCT #	Clamp
968-000-016	CL-6
968-000-017	CL-7
968-000-020	CL-9
968-000-010	CL-12
968-000-011	CL-19
968-000-012	CL-20

PACKAGE SIZE OF 1

PRODUCT #	Clamp
968-000-013	CL-21
968-000-014	CL-22
968-000-015	CL-30
968-000-018	CL-84
968-000-019	CL-85

PACKAGE SIZE OF 1

PRODUCT #	Clamp Screw
968-000-176	XNS-36
968-000-177	XNS-47
968-000-178	XNS-48
968-000-179	XNS-510
968-000-180	XNS-58
968-000-181	XNS-59

PACKAGE SIZE OF 5

STEEL

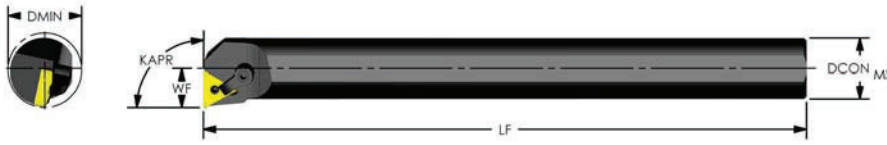

Negative Triangle (KAPR: 90°)

4:1 Ratio
No Coolant

PRODUCT #	Designation	DCON MS	LF	WF	DMIN	KAPR	Insert	Shim Seat	Clamp	Clamp Screw	Lock Pin
957-000-394	S16S MTFNR3	1.000	10.000	0.640	1.200	90.0	TNMG 332		CL-7	XNS-36	NL-33L
957-000-408	S20S MTFNR3	1.250	10.000	0.765	1.470	90.0	TNMG 332	ITSN-23	CL-7	XNS-36	NL-34L
957-000-421	S20U MTFNR3	1.250	14.000	0.765	1.470	90.0	TNMG 332	ITSN-323	CL-7	XNS-36	NL-34L
957-000-435	S24U MTFNR4	1.500	14.000	0.890	1.730	90.0	TNMG 432	ITSN-433	CL-20	XNS-47	NL-46

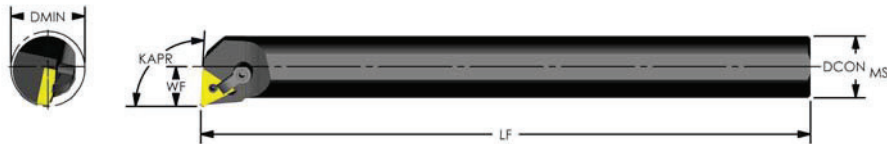

Negative Triangle (KAPR: 93°)

4:1 Ratio
No Coolant

PRODUCT #	Designation	DCON MS	LF	WF	DMIN	KAPR	Insert	Shim Seat	Clamp	Clamp Screw	Lock Pin
957-000-395	S16S MTUNR3	1.000	10.000	0.640	1.200	93.0	TNMG 332	N/A	CL-7	XNS-36	NL-33L
957-000-409	S20S MTUNR3	1.250	10.000	0.765	1.470	93.0	TNMG 332	ITSN-323	CL-7	XNS-36	NL-34L
957-000-422	S20U MTUNR3	1.250	14.000	0.765	1.470	93.0	TNMG 332	ITSN-323	CL-7	XNS-36	NL-34L
957-000-436	S24U MTUNR4	1.500	14.000	0.890	1.730	93.0	TNMG 432	ITSN-433	CL-20	XNS-47	NL-46

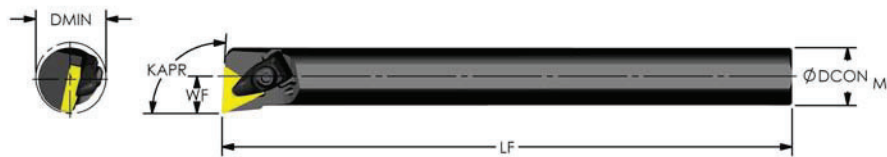

Negative Triangle (KAPR: 93°)

4:1 Ratio
Coolant Thru

PRODUCT #	Designation	DCON MS	LF	WF	DMIN	KAPR	Insert	Shim	Shim Screw	Clamp Assy.
957-000-150	A16S DTUNR4	1.000	10.000	0.640	1.200	93.0	TNMG 432	N/A	N/A	PB4-CA
957-000-177	A20U DTUNR4	1.250	14.000	0.765	1.470	93.0	TNMG 432	ITSN-433	PB4-SS	PB4-CA
957-000-188	A24U DTUNR4	1.500	14.000	0.890	1.730	93.0	TNMG 432	ITSN-433	PB4-SS	PB4-CA

PRODUCT #	Shim Seat
968-000-053	ICSN-433
968-000-054	ICSN-533
968-000-055	ICSN-633
968-000-063	ISSN-432
968-000-064	ISSN-433
968-000-065	ISSN-533
968-000-066	ISSN-633
968-000-056	IDSN-322
968-000-057	IDSN-433
968-000-058	IDSN-533
968-000-067	ITSN-323
968-000-068	ITSN-433

PACKAGE SIZE OF 10

PRODUCT #	Shim Seat
968-000-069	ITSN-533
968-000-070	ITSN-636
968-000-071	IVSN-322
968-000-072	IVSN-432
968-000-073	IVSN-433
968-000-074	IWSN-322
968-000-075	IWSN-433
968-000-059	IRSN-32
968-000-060	IRSN-43
968-000-061	IRSN-53
968-000-062	IRSN-63

PACKAGE SIZE OF 10

PRODUCT #	Lock Pin
968-000-097	NL-33
968-000-098	NL-33L
968-000-099	NL-34
968-000-100	NL-34L
968-000-101	NL-44
968-000-102	NL-46
968-000-103	NL-56
968-000-104	NL-58
968-000-105	NL-68
968-000-106	NL-68L

PACKAGE SIZE OF 5

ULTRA-DEX[®]

STEEL

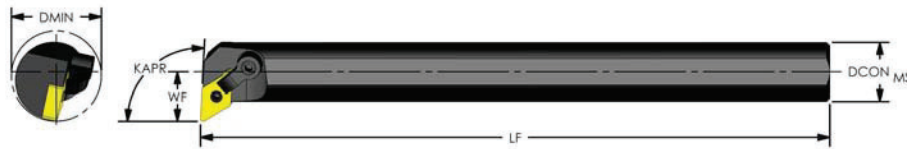

Negative 55° Diamond (KAPR: 93°) Profiling

4:1 Ratio
No Coolant

PRODUCT # Left hand	PRODUCT # Right hand	Designation	DCON MS	LF	WF	DMIN	KAPR	Insert	Shim Seat	Clamp	Clamp Screw	Lock Pin
957-000-363	957-000-364	S12R MDUNR/L3	0.750	8.000	0.625	1.050	93.0	DNMG 432	N/A	CL-7	XNS-36	NL-33L
957-000-392	957-000-393	S16S MDUNR/L3	1.000	10.000	0.750	1.310	93.0	DNMG 432	N/A	CL-7	XNS-36	NL-33L
957-000-414	957-000-416	S20T MDUNR/L3	1.250	12.000	1.000	1.700	93.0	DNMG 432	IDSN-322	CL-7	XNS-36	NL-34L
957-000-415	957-000-417	S20T MDUNR/L4	1.250	12.000	1.000	1.700	93.0	DNMG 432	IDSN-433	CL-22	XNS-48	NL-46
957-000-433	957-000-434	S24U MDUNR/L4	1.500	14.000	1.125	1.960	93.0	DNMG 432	IDSN-433	CL-22	XNS-48	NL-46

Coolant Thru

PRODUCT # Left hand	PRODUCT # Right hand	Designation	DCON MS	LF	WF	DMIN	KAPR	Insert	Shim Seat	Clamp	Clamp Screw	Lock Pin
957-000-127	957-000-128	A12R MDUNR/L3	0.750	8.000	0.625	1.050	93.0	DNMG 332	N/A	CL-7	XNS-36	NL-33L
957-000-155	957-000-156	A16S MDUNR/L3	1.000	10.000	0.750	1.310	93.0	DNMG 332	N/A	CL-7	XNS-36	NL-33L
957-000-171	957-000-173	A20T MDUNR/L3	1.250	12.000	1.000	1.700	93.0	DNMG 332	IDSN-322	CL-7	XNS-36	NL-34L
957-000-172	957-000-174	A20T MDUNR/L4	1.250	12.000	1.000	1.700	93.0	DNMG 432	IDSN-433	CL-22	XNS-48	NL-46
957-000-193	957-000-194	A24U MDUNR/L4	1.500	14.000	1.125	1.960	93.0	DNMG 432	IDSN-433	CL-22	XNS-48	NL-46

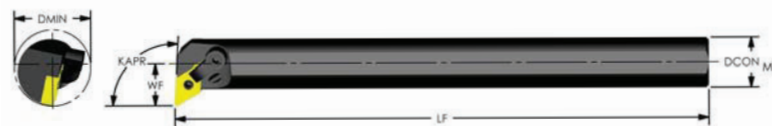

Negative 55° Diamond (KAPR: 93°)

4:1 Ratio
Coolant Thru

PRODUCT #	Designation	DCON MS	LF	WF	DMIN	KAPR	Insert	Shim	Shim Screw	Clamp Assy.
957-000-168	A20T DDUNR4	1.250	12	1.000	1.700	93.0	DNMG 432	IDSN 433	PB4-SS	PB4-CA
957-000-187	A24U DDUNR4	1.500	14	1.125	1.965	93.0	DNMG 432	IDSN 433	PB4-SS	PB4-CA

PRODUCT #	Shim Screw
968-000-109	PB3-SS
968-000-111	PB4-SS

PACKAGE SIZE OF 5

PRODUCT #	Clamp Assy.
968-000-107	PB3-CA
968-000-110	PB4-CA

PACKAGE SIZE OF 1

PRODUCT #	Clamp
968-000-016	CL-6
968-000-017	CL-7
968-000-020	CL-9
968-000-010	CL-12
968-000-011	CL-19
968-000-012	CL-20

PACKAGE SIZE OF 1

PRODUCT #	Clamp
968-000-013	CL-21
968-000-014	CL-22
968-000-015	CL-30
968-000-018	CL-84
968-000-019	CL-85

PACKAGE SIZE OF 1

PRODUCT #	Clamp Screw
968-000-176	XNS-36
968-000-177	XNS-47
968-000-178	XNS-48
968-000-179	XNS-510
968-000-180	XNS-58
968-000-181	XNS-59

PACKAGE SIZE OF 5

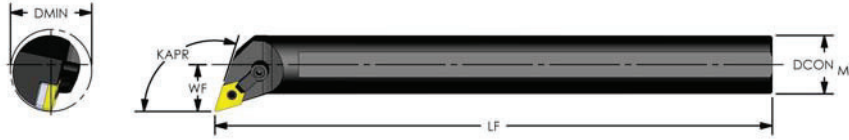

Negative 55° Diamond (KAPR: 72.5°) Profiling

4:1 Ratio
No Coolant

PRODUCT # Left hand	PRODUCT # Right hand	Designation	DCON MS	LF	WF	DMIN	KAPR	Insert	Shim Seat	Clamp	Clamp Screw	Lock Pin
957-000-412	957-000-413	S20T MDQNR/L4	1.250	12.000	1.000	1.700	72.5	DNMG 432	IDSN-433	CL-22	XNS-48	NL-46
957-000-431	957-000-432	S24U MDQNR/L4	1.500	14.000	1.125	1.960	72.5	DNMG 432	IDSN-433	CL-22	XNS-48	NL-46

Coolant Thru

PRODUCT # Left hand	PRODUCT # Right hand	Designation	DCON MS	LF	WF	DMIN	KAPR	Insert	Shim Seat	Clamp	Clamp Screw	Lock Pin
957-000-169	957-000-170	A20T MDQNR/L4	1.250	12.000	1.000	1.700	72.5	DNMG 432	IDSN-433	CL-22	XNS-48	NL-46
957-000-191	957-000-192	A24U MDQNR/L4	1.500	14.000	1.125	1.960	72.5	DNMG 432	IDSN-433	CL-22	XNS-48	NL-46

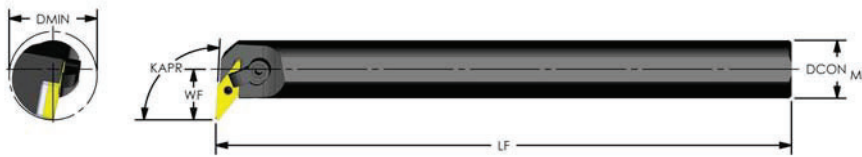

Negative 35° Diamond (KAPR: 93°) Profiling

4:1 Ratio
No Coolant

PRODUCT # Right hand	Designation	DCON MS	LF	WF	DMIN	KAPR	Insert	Shim Seat	Clamp	Clamp Screw	Lock Pin
957-000-396	S16S MVUNR3	1.000	10.000	.875	1.435	93.0	VNMG 332	IVSN-322	CL-20	XNS-47	NL-34L
957-000-418	S20T MVUNR3	1.250	12.000	1.000	1.705	93.0	VNMG 332	IVSN-322	CL-20	XNS-47	NL-34L
957-000-437	S24U MVUNR3	1.500	14.000	1.120	1.960	93.0	VNMG 332	IVSN-322	CL-20	XNS-47	NL-34L

Coolant Thru

PRODUCT # Right hand	Designation	DCON MS	LF	WF	DMIN	KAPR	Insert	Shim Seat	Clamp	Clamp Screw	Lock Pin
957-000-157	A16S MVUNR3	1.000	10.000	0.875	1.435	93.0	VNMG 332	IVSN-322	CL-20	XNS-47	NL-34L
957-000-175	A20T MVUNR3	1.250	12.000	1.000	1.705	93.0	VNMG 332	IVSN-322	CL-20	XNS-47	NL-34L
957-000-195	A24U MVUNR3	1.500	14.000	1.120	1.960	93.0	VNMG 332	IVSN-322	CL-20	XNS-47	NL-34L

PRODUCT #	Shim Seat
968-000-053	ICSN-433
968-000-054	ICSN-533
968-000-055	ICSN-633
968-000-063	ISSN-432
968-000-064	ISSN-433
968-000-065	ISSN-533
968-000-066	ISSN-633
968-000-056	IDSN-322
968-000-057	IDSN-433
968-000-058	IDSN-533
968-000-067	ITSN-323
968-000-068	ITSN-433

PACKAGE SIZE OF 10

PRODUCT #	Shim Seat
968-000-069	ITSN-533
968-000-070	ITSN-636
968-000-071	IVSN-322
968-000-072	IVSN-432
968-000-073	IVSN-433
968-000-074	IWSN-322
968-000-075	IWSN-433
968-000-059	IRSN-32
968-000-060	IRSN-43
968-000-061	IRSN-53
968-000-062	IRSN-63

PACKAGE SIZE OF 10

PRODUCT #	Lock Pin
968-000-097	NL-33
968-000-098	NL-33L
968-000-099	NL-34
968-000-100	NL-34L
968-000-101	NL-44
968-000-102	NL-46
968-000-103	NL-56
968-000-104	NL-58
968-000-105	NL-68
968-000-106	NL-68L

PACKAGE SIZE OF 5

ULTRA-DEX[®]

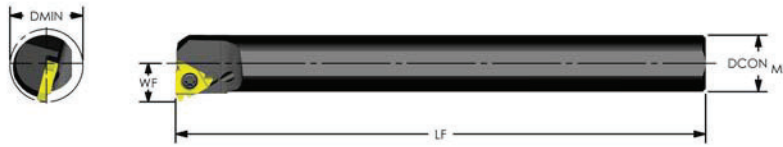

Threading/Grooving Laydown

4:1 Ratio
Coolant Thru

PRODUCT #	Designation Right Hand	DCON MS	LF	WF	L	DMIN	Insert	Insert Screw	Anvil Screw	Anvil
957-000-046	A08M LSER2	0.500	6.000	0.308	N/A	0.588	2IR	SR34505	N/A	N/A
957-000-082	A10Q LSER2	0.625	7.000	0.371	N/A	0.721	2IR	SR34505	N/A	N/A
957-000-105	A12Q LSER3	0.750	7.000	0.510	N/A	0.935	3IR	MTS-35	N/A	N/A
957-000-132	A16R LSER3	1.000	8.000	0.650	N/A	1.210	3IR	SA3T	SY3T	Y13

PRODUCT #	Designation Left Hand	DCON MS	LF	WF	L	DMIN	Insert	Insert Screw	Anvil Screw	Anvil
957-000-104	A12Q LSEL3	0.750	7.000	0.510	N/A	0.935	3IL	MTS-35	N/A	N/A
957-000-131	A16R LSEL3	1.000	8.000	0.650	N/A	1.210	3IL	SA3T	SY3T	YE3

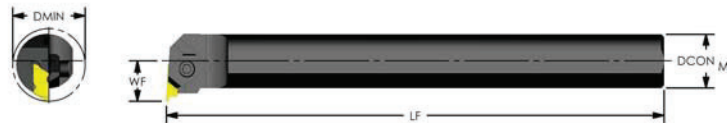

Threading/Grooving Top Notch

4:1 Ratio
No Coolant

PRODUCT #	Designation Right Hand	DCON MS	LF	WF	DMIN	Insert	Clamp	Clamp Screw
957-000-273	S08M NER2	0.500	6.000	0.437	0.730	NG 2L	CM-147	6-32
957-000-312	S10Q NER2	0.625	7.000	0.500	1.000	N/A	CM-75	6-32
957-000-338	S12Q NER2	0.750	7.000	0.562	1.120	N/A	CM-75	6-32
957-000-369	S16R NER3	1.000	8.000	0.688	1.250	NG 3L	CM-73	10-32

PRODUCT #	Designation Left Hand	DCON MS	LF	WF	DMIN	Insert	Clamp	Clamp Screw
957-000-272	S08M NEL2	0.500	6.000	0.437	0.730	NG 2R	CM-146	6-32
957-000-311	S10Q NEL2	0.625	7.000	0.500	1.000	NG 2R	CM-74	6-32
957-000-337	S12Q NEL2	0.750	7.000	0.562	1.120	NG 2R	CM-74	6-32
957-000-368	S16R NEL3	1.000	8.000	0.688	1.250	NG 3R	CM-72	10-32

PRODUCT #	Clamp
968-000-016	CL-6
968-000-017	CL-7
968-000-020	CL-9
968-000-010	CL-12
968-000-011	CL-19
968-000-012	CL-20

PACKAGE SIZE OF 1

PRODUCT #	Clamp
968-000-013	CL-21
968-000-014	CL-22
968-000-015	CL-30
968-000-018	CL-84
968-000-019	CL-85

PACKAGE SIZE OF 1

PRODUCT #	Anvil
968-000-185	Y13
968-000-182	YE3
968-000-187	Y14
968-000-186	Y13M-1.5N
968-000-183	YE4
968-000-188	Y15
968-000-184	YE5

PACKAGE SIZE OF 1

PRODUCT #	Anvil Screw
968-000-146	SY3T
968-000-147	SY4T
968-000-148	SY5T

PACKAGE SIZE OF 5

PRODUCT #	Insert Screw
968-000-124	SA3T
968-000-125	SA4T
968-000-126	SA5T

PACKAGE SIZE OF 5

STEEL

957-000-204



Coolant Thru

- (1) A06K SCLCR2 (3/8" Bar)
- (1) A08M SCLCR2 (1/2" Bar)
- (1) A10Q SCLCR2 (5/8" Bar)
- (5) CCMT 21.51 ZX3-UD51

957-000-205



Coolant Thru

- (1) A10Q SCLCR3 (5/8" Bar)
- (1) A12Q SCLCR3 (3/4" Bar)
- (1) A16R SCLCR3 (1" Bar)
- (5) CCMT 32.51 ZX3-UD51

957-000-206



No Coolant

- (1) S03G SCLDR1.2
- (1) S03.5G SCLDR1.5
- (1) S04G SCLDR1.5
- (1) S05G SCLPR1.8
- (2) CDHB 1.20.60 UD51
- (2) CDGW 1.510 UD51
- (2) CPMT 1.81.20.5 LX6-UD52

PRODUCT #	PRODUCT KITS
957-000-204	PDBK-356
957-000-205	PDBK-671
957-000-206	PDBK-MINI

ULTRA-DEX[®]

STEEL

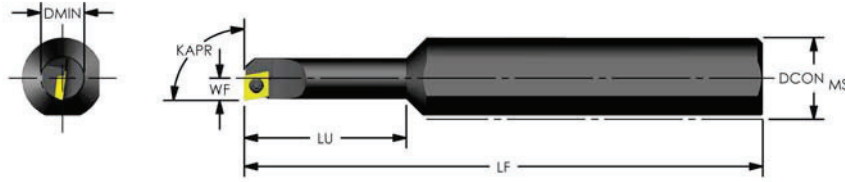

Positive 80° Diamond (KAPR: 90°) Reduced Neck

No Coolant

PRODUCT #	Designation	DCON MS	LF	LU	WF	DMIN	KAPR	Insert	Insert Screw	Key
957-000-450	SCFDR2-5	0.625	4.000	0.500	0.138	0.276	90.0	CDGW 1.510	MTS-184	T-6
957-000-446	SCFDR2-15	0.625	4.000	1.000	0.138	0.276	90.0	CDGW 1.510	MTS-184	T-6
957-000-447	SCFDR2-25	0.625	4.000	0.750	0.167	0.334	90.0	CDGW 1.510	MTS-184	T-6
957-000-448	SCFDR2-35	0.625	4.000	1.250	0.167	0.334	90.0	CDGW 1.510	MTS-184	T-6
957-000-449	SCFDR2-45	0.625	4.000	1.000	0.203	0.450	90.0	CDGW 1.510	MTS-184	T-6
957-000-451	SCFDR2-55	0.625	4.000	1.500	0.203	0.450	90.0	CDGW 1.510	MTS-184	T-6

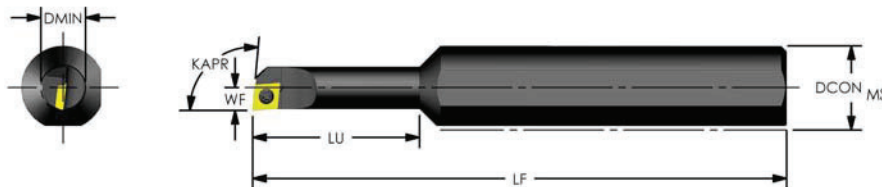

Positive 80° Diamond (KAPR: 95°) Reduced Neck

No Coolant

PRODUCT #	Designation	DCON MS	LF	LU	WF	DMIN	KAPR	Insert	Insert Screw	Key
957-000-456	SCLDR2-5	0.625	4.000	0.500	0.138	0.276	95.0	CDGW 1.510	MTS-184	T-6
957-000-452	SCLDR2-15	0.625	4.000	1.000	0.138	0.276	95.0	CDGW 1.510	MTS-184	T-6
957-000-453	SCLDR2-25	0.625	4.000	0.750	0.167	0.334	95.0	CDGW 1.510	MTS-184	T-6
957-000-454	SCLDR2-35	0.625	4.000	1.250	0.167	0.334	95.0	CDGW 1.510	MTS-184	T-6
957-000-455	SCLDR2-45	0.625	4.000	1.000	0.203	0.450	95.0	CDGW 1.510	MTS-184	T-6
957-000-457	SCLDR2-55	0.625	4.000	1.500	0.203	0.450	95.0	CDGW 1.510	MTS-184	T-6

PRODUCT #	Insert Screws
968-000-086	MTS-183
968-000-087	MTS-184
968-000-088	MTS-2
968-000-091	MTS-224
968-000-092	MTS-255
968-000-094	MTS-35
968-000-090	MTS-2.5L
968-000-052	ETS 4-40

PACKAGE SIZE OF 5

PRODUCT #	Key
968-000-156	T-6
968-000-158	T-7
968-000-149	T-10
968-000-151	T-15
968-000-153	T-20

PACKAGE SIZE OF 5

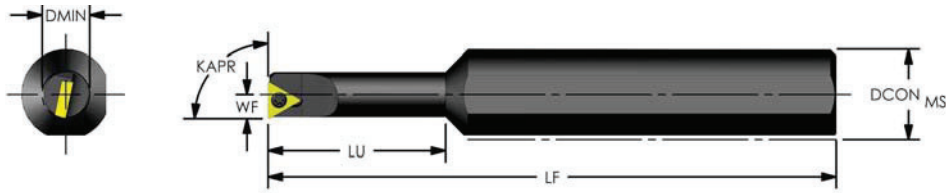

Positive Triangle (KAPR: 90°) Reduced Neck

No Coolant

PRODUCT #	Designation	DCON MS	LF	LU	WF	DMIN	KAPR	Insert	Insert Screw	Key
957-000-462	STFCR2-5	0.625	4.000	0.500	0.138	0.276	90.0	TCMT 1.21.20.5	MTS-184	T-6
957-000-458	STFCR2-15	0.625	4.000	1.000	0.138	0.276	90.0	TCMT 1.21.20.5	MTS-184	T-6
957-000-459	STFCR2-25	0.625	4.000	0.750	0.167	0.334	90.0	TCMT 1.21.20.5	MTS-184	T-6
957-000-460	STFCR2-35	0.625	4.000	1.250	0.167	0.334	90.0	TCMT 1.21.20.5	MTS-184	T-6
957-000-461	STFCR2-45	0.625	4.000	1.000	0.203	0.450	90.0	TCMT 1.21.20.5	MTS-184	T-6
957-000-463	STFCR2-55	0.625	4.000	1.500	0.203	0.450	90.0	TCMT 1.21.20.5	MTS-184	T-6

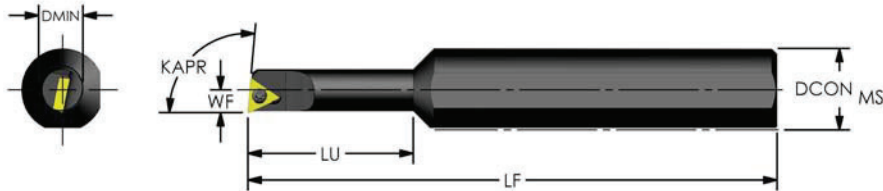

Positive Triangle (KAPR: 95°) Reduced Neck

No Coolant

PRODUCT #	Designation	DCON MS	LF	LU	WF	DMIN	KAPR	Insert	Insert Screw	Key
957-000-468	STLCR2-5	0.625	4.000	0.500	0.138	0.276	95.0	TCMT 1.21.20.5	MTS-184	T-6
957-000-464	STLCR2-15	0.625	4.000	1.000	0.138	0.276	95.0	TCMT 1.21.20.5	MTS-184	T-6
957-000-465	STLCR2-25	0.625	4.000	0.750	0.167	0.334	95.0	TCMT 1.21.20.5	MTS-184	T-6
957-000-466	STLCR2-35	0.625	4.000	1.250	0.167	0.334	95.0	TCMT 1.21.20.5	MTS-184	T-6
957-000-467	STLCR2-45	0.625	4.000	1.000	0.203	0.450	95.0	TCMT 1.21.20.5	MTS-184	T-6
957-000-469	STLCR2-55	0.625	4.000	1.500	0.203	0.450	95.0	TCMT 1.21.20.5	MTS-184	T-6

PRODUCT #	Insert Screws
968-000-086	MTS-183
968-000-087	MTS-184
968-000-088	MTS-2
968-000-091	MTS-224
968-000-092	MTS-255
968-000-094	MTS-35
968-000-090	MTS-2.5L
968-000-052	ETS 4-40

PACKAGE SIZE OF 5

PRODUCT #	Key
968-000-156	T-6
968-000-158	T-7
968-000-149	T-10
968-000-151	T-15
968-000-153	T-20

PACKAGE SIZE OF 5

ULTRA-DEX[®]

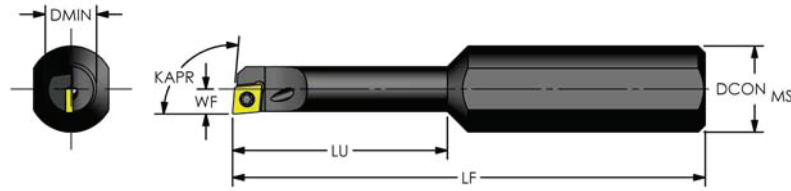

Positive 80° Diamond (KAPR: 95°) Reduced Neck **SERIES "C"**

Coolant Thru

PRODUCT #	Designation	DCON MS	KAPR	LF	LU	WF	DMIN	KAPR	Insert	Insert Screw	Key
915-000-017	CSUD-180/375-1/2-5R	0.375	0.180	2.500	0.500	0.104	0.208	95.0	CDHB 1.20.60.5	MTS-183	T-6
915-000-018	CSUD-180/375-1-5R	0.375	0.180	2.500	1.000	0.104	0.208	95.0	CDHB 1.20.60.5	MTS-183	T-6
915-000-022	CSUD-203/375-1/2-5R	0.375	0.203	2.500	0.500	0.116	0.230	95.0	CDHB 1.20.60.5	MTS-183	T-6
915-000-023	CSUD-203/375-1-5R	0.375	0.203	2.500	1.000	0.116	0.230	95.0	CDHB 1.20.60.5	MTS-183	T-6
915-000-026	CSUD-250/375-11/4-5R	0.375	0.250	2.500	1.250	0.145	0.285	95.0	CDHB 1.20.60.5	MTS-183	T-6
915-000-019	CSUD-180/500-1/2-5R	0.500	0.180	2.750	0.500	0.104	0.208	95.0	CDHB 1.20.60.5	MTS-183	T-6
915-000-020	CSUD-180/500-1-5R	0.500	0.180	2.750	1.000	0.104	0.208	95.0	CDHB 1.20.60.5	MTS-183	T-6
915-000-024	CSUD-203/500-1/2-5R	0.500	0.203	2.750	0.500	0.116	0.230	95.0	CDHB 1.20.60.5	MTS-183	T-6
915-000-025	CSUD-203/500-1-5R	0.500	0.203	2.750	1.000	0.116	0.230	95.0	CDHB 1.20.60.5	MTS-183	T-6
915-000-028	CSUD-250/500-3/4-5R	0.500	0.250	2.750	0.750	0.145	0.285	95.0	CDHB 1.20.60.5	MTS-184	T-6
915-000-027	CSUD-250/500-11/4-5R	0.500	0.250	2.750	1.250	0.145	0.285	95.0	CDHB 1.20.60.5	MTS-184	T-6

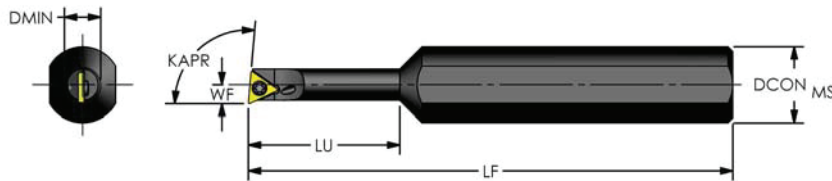

Positive Triangle (KAPR: 95°) Reduced Neck **SERIES "F, Q"**

Coolant Thru

PRODUCT #	Designation	DCON MS	KAPR	LF	LU	WF	DMIN	KAPR	Insert	Insert Screw	Key
915-000-041	FSUD-203/500-1/2-5R	0.500	0.203	3.000	0.500	0.126	0.275	95.0	TDHB 1.280.750.5	MTS-224	T-7
915-000-042	FSUD-203/500-1-5R	0.500	0.203	3.000	1.000	0.126	0.275	95.0	TDHB 1.280.750.5	MTS-224	T-7
915-000-044	FSUD-250/500-3/4-5R	0.500	0.259	3.000	0.750	0.156	0.300	95.0	TDHB 1.280.750.5	MTS-224	T-7
915-000-050	FSUD-312/500-1-5R	0.500	0.321	3.000	1.000	0.187	0.360	95.0	TDHB 1.280.750.5	MTS-224	T-7
915-000-049	FSUD-312/500-11/2-5R	0.500	0.321	3.000	1.500	0.187	0.360	95.0	TDHB 1.280.750.5	MTS-224	T-7
915-000-043	FSUD-203/625-1/2-5R	0.625	0.203	4.000	0.500	0.126	0.275	95.0	TDHB 1.280.750.5	MTS-224	T-7
915-000-046	FSUD-250/625-3/4-5R	0.625	0.259	4.000	0.750	0.156	0.300	95.0	TDHB 1.280.750.5	MTS-224	T-7
915-000-045	FSUD-250/625-11/4-5R	0.625	0.259	4.000	1.250	0.156	0.300	95.0	TDHB 1.280.750.5	MTS-224	T-7
915-000-051	FSUD-312/625-1-5R	0.625	0.321	4.000	1.000	0.187	0.360	95.0	TDHB 1.280.750.5	MTS-224	T-7
915-000-072	QSUD-375/500-11/8-5R	0.500	0.390	3.750	1.125	0.221	0.438	95.0	TPCB 220.5	ETS 4-40	T-10
915-000-073	QSUD-375/500-17/8-5R	0.500	0.390	3.750	1.875	0.221	0.438	95.0	TPCB 220.5	ETS 4-40	T-10
915-000-074	QSUD-375/625-11/8-5R	0.625	0.390	4.250	1.125	0.221	0.438	95.0	TPCB 220.5	ETS 4-40	T-10
915-000-075	QSUD-375/625-17/8-5R	0.625	0.390	4.250	1.875	0.221	0.438	95.0	TPCB 220.5	ETS 4-40	T-10
915-000-076	QSUD-375/750-11/2-5R	0.750	0.390	4.000	1.500	0.221	0.438	95.0	TPCB 220.5	ETS 4-40	T-10
915-000-081	QSUD-625/750-21/2-5R	0.750	0.635	4.500	2.500	0.353	0.688	95.0	TPCB 220.5	ETS 4-40	T-10

PRODUCT #	Insert Screws
968-000-086	MTS-183
968-000-087	MTS-184
968-000-088	MTS-2
968-000-091	MTS-224
968-000-092	MTS-255
968-000-094	MTS-35
968-000-090	MTS-2.5L
968-000-052	ETS 4-40

PRODUCT #	Key
968-000-156	T-6
968-000-158	T-7
968-000-149	T-10
968-000-151	T-15
968-000-153	T-20

PACKAGE SIZE OF 5

PACKAGE SIZE OF 5

STEEL

CARBIDE BORING BARS

Maximum rigidity and
efficiency for use in
tougher applications

Up to 8:1 Ratio

.156"-1.5" Diameters



CARBIDE

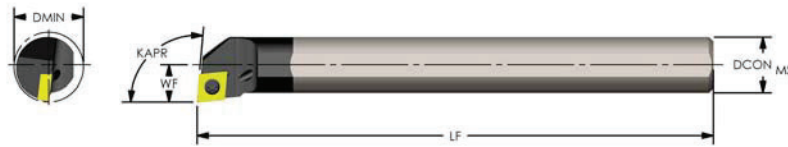

Positive 80° Diamond (KAPR: 95°)

8:1 Ratio
Coolant Thru

PRODUCT # Left hand	PRODUCT # Right hand	Designation	DCON MS (mm)	LF (mm)	WF (mm)	DMIN (mm)	KAPR	Insert	Insert Screw	Key
920-000-428	920-000-429	M-E06H SCLDR/L04*	6.00	100.00	3.50	7.00	95.0	CDGW 1.510	MTS-184	T-6
920-000-432	920-000-433	M-E08K SCLCR/L06*	8.00	125.00	6.00	11.00	95.0	CCMT 21.51	MTS-255	T-7
920-000-436	920-000-437	M-E10M SCLCR/L06	10.00	150.00	7.00	13.00	95.0	CCMT 21.51	MTS-255	T-7
920-000-442	920-000-443	M-E12Q SCLCR/L06	12.00	180.00	9.00	16.00	95.0	CCMT 21.51	MTS-255	T-7
920-000-448	920-000-449	M-E16R SCLCR/L09	16.00	200.00	11.00	20.00	95.0	CCMT 32.51	MTS-35	T-15
920-000-454	920-000-455	M-E20S SCLCR/L09	20.00	250.00	13.00	25.00	95.0	CCMT 32.51	MTS-35	T-15
920-000-460	920-000-461	M-E25T SCLCR/L09	25.00	300.00	17.00	32.00	95.0	CCMT 32.51	MTS-35	T-15

*bars 8mm and smaller do not have flats

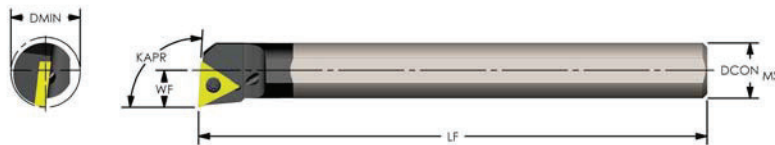

Positive Triangle (KAPR: 93°)

8:1 Ratio
Coolant Thru

PRODUCT # Left hand	PRODUCT # Right hand	Designation	DCON MS (mm)	LF (mm)	WF (mm)	DMIN (mm)	KAPR	Insert	Insert Screw	Key
920-000-430	920-000-431	M-E06H STUCR/L06*	6.00	100.00	3.50	7.00	93.0	TCMT 1.21.20.5	MTS-184	T-6
920-000-434	920-000-435	M-E08K STUCR/L06*	8.00	125.00	6.00	11.00	93.0	TCMT 1.21.20.5	MTS-184	T-6
920-000-440	920-000-441	M-E10M STUCR/L11	10.00	150.00	7.00	13.00	93.0	TCMT 21.51	MTS-255	T-7
920-000-446	920-000-447	M-E12Q STUCR/L11	12.00	180.00	9.00	16.00	93.0	TCMT 21.51	MTS-255	T-7
920-000-452	920-000-453	M-E16R STUCR/L11	16.00	200.00	11.00	20.00	93.0	TCMT 21.51	MTS-255	T-7
920-000-458	920-000-459	M-E20S STUCR/L16	20.00	250.00	13.00	25.00	93.0	TCMT 32.51	MTS-35	T-15
920-000-464	920-000-465	M-E25T STUCR/L16	25.00	300.00	17.00	32.00	93.0	TCMT 32.51	MTS-35	T-15

*bars 8mm and smaller do not have flats

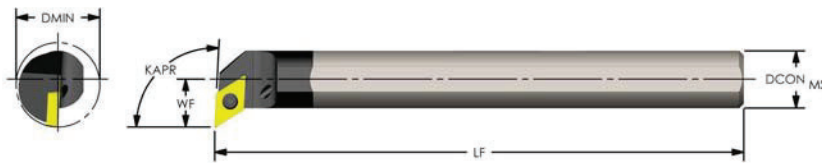

Positive 55° Diamond (KAPR: 93°) Profiling

8:1 Ratio
Coolant Thru

PRODUCT # Left hand	PRODUCT # Right hand	Designation	DCON MS (mm)	LF (mm)	WF (mm)	DMIN (mm)	KAPR	Insert	Insert Screw	Key
920-000-438	920-000-439	M-E10M SDUCR/L07	10.00	150.00	9.00	15.00	93.0	DCMT 21.51	MTS-255	T-7
920-000-444	920-000-445	M-E12Q SDUCR/L07	12.00	180.00	11.00	18.00	93.0	DCMT 21.51	MTS-255	T-7
920-000-450	920-000-451	M-E16R SDUCR/L07	16.00	200.00	13.00	22.00	93.0	DCMT 21.51	MTS-255	T-7
920-000-456	920-000-457	M-E20S SDUCR/L11	20.00	250.00	15.00	27.00	93.0	DCMT 32.51	MTS-35	T-15
920-000-462	920-000-463	M-E25T SDUCR/L11	25.00	300.00	18.00	33.00	93.0	DCMT 32.51	MTS-35	T-15



by **Ultra-Dex**

CARBIDE

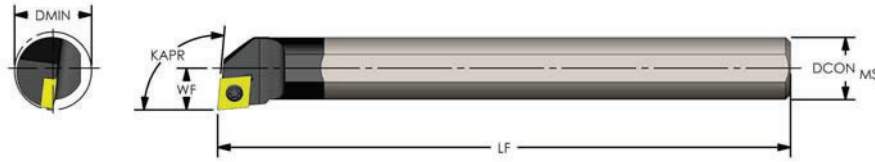

Positive 80° Diamond (KAPR: 95°)

**8:1 Ratio
No Coolant**

PRODUCT # Left hand	PRODUCT # Right hand	Designation	DCON MS	LF	WF	DMIN	KAPR	Insert	Insert Screw	Key
920-000-001	920-000-002	C02.5G SCLDR/L1.2*	0.156	3.500	0.090	0.175	95.0	CDHB 1.20.60	MTS-183	T-6
920-000-005	920-000-006	C03H SCLDR/L1.2*	0.187	4.000	0.102	0.205	95.0	CDHB 1.20.60	MTS-183	T-6
920-000-003	920-000-004	C03.5H SCLDR/L1.5*	0.218	4.000	0.125	0.245	95.0	CDGW 1.510	MTS-184	T-6
920-000-008	920-000-010	C04H SCLDR/L1.5*	0.250	4.000	0.172	0.312	95.0	CDGW 1.510	MTS-184	T-6
920-000-018	920-000-020	C05K SCLPR/L1.8*	0.312	5.000	0.219	0.395	95.0	CPMT 1.81.20.5	MTS-224	T-7
920-000-032	920-000-034	C06M SCLPR/L2	0.375	6.000	0.250	0.460	95.0	CPMT 21.51	MTS-255	T-7
920-000-062	920-000-065	C08J SCLPR/L2	0.500	4.500	0.312	0.600	95.0	CPMT 21.51	MTS-255	T-7
920-000-094	920-000-097	C08R SCLPR/L2	0.500	8.000	0.312	0.600	95.0	CPMT 21.51	MTS-255	T-7
920-000-064	920-000-067	C08J SCLPR/L3	0.500	4.500	0.344	0.625	95.0	CPMT 32.51	MTS-35	T-15
920-000-096	920-000-099	C08R SCLPR/L3	0.500	8.000	0.344	0.625	95.0	CPMT 32.51	MTS-35	T-15
920-000-028	920-000-030	C06M SCLCR/L2	0.375	6.000	0.250	0.460	95.0	CCMT 21.51	MTS-255	T-7
920-000-056	920-000-059	C08J SCLCR/L2	0.500	4.500	0.312	0.600	95.0	CCMT 21.51	MTS-255	T-7
920-000-088	920-000-091	C08R SCLCR/L2	0.500	8.000	0.312	0.600	95.0	CCMT 21.51	MTS-255	T-7
920-000-058	920-000-061	C08J SCLCR/L3	0.500	4.500	0.344	0.625	95.0	CCMT 32.51	MTS-35	T-15
920-000-090	920-000-093	C08R SCLCR/L3	0.500	8.000	0.344	0.625	95.0	CCMT 32.51	MTS-35	T-15

Minimum Clearance

No Coolant

PRODUCT # Left hand	PRODUCT # Right hand	Designation	DCON MS	LF	WF	DMIN	KAPR	Insert	Insert Screw	Key
920-000-009	920-000-011	C04H SCLDR/L1.5-138 *	0.250	4.000	0.138	0.275	95.0	CDGW 1.510	MTS-184	T-6
920-000-019	920-000-021	C05K SCLPR/L1.8-167 *	0.312	5.000	0.167	0.340	95.0	CPMT 1.81.20.5	MTS-224	T-7
920-000-033	920-000-035	C06M SCLPR/L2-203	0.375	6.000	0.203	0.410	95.0	CPMT 21.51	MTS-255	T-7
920-000-063	920-000-066	C08J SCLPR/L2-281	0.500	4.500	0.281	0.560	95.0	CPMT 21.51	MTS-255	T-7
920-000-095	920-000-098	C08R SCLPR/L2-281	0.500	8.000	0.281	0.560	95.0	CPMT 21.51	MTS-255	T-7
920-000-029	920-000-031	C06M SCLCR/L2-203	0.375	6.000	0.203	0.410	95.0	CCMT 21.51	MTS-255	T-7
920-000-057	920-000-060	C08J SCLCR/L2-281	0.500	4.500	0.281	0.560	95.0	CCMT 21.51	MTS-255	T-7
920-000-089	920-000-092	C08R SCLCR/L2-281	0.500	8.000	0.281	0.560	95.0	CCMT 21.51	MTS-255	T-7

Minimum Clearance Bars are intended for light machining with minimum bore clearance. Max depth of cut .015" - .020"
*bars .312 and smaller do not have flats

PRODUCT #	Insert Screws
968-000-086	MTS-183
968-000-087	MTS-184
968-000-088	MTS-2
968-000-091	MTS-224
968-000-092	MTS-255
968-000-094	MTS-35
968-000-090	MTS-2.5L
968-000-052	ETS 4-40

PACKAGE SIZE OF 5

PRODUCT #	Key
968-000-156	T-6
968-000-158	T-7
968-000-149	T-10
968-000-151	T-15
968-000-153	T-20

PACKAGE SIZE OF 5

USE THE RIGHT SET SCREW FLAT POINT, NOT CUP POINT

CARBIDE

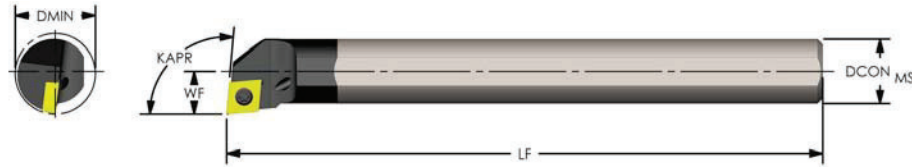

Positive 80° Diamond (KAPR: 95°)

8:1 Ratio
Coolant Thru

PRODUCT # Left hand	PRODUCT # Right hand	Designation	DCON MS	LF	WF	DMIN	KAPR	Insert	Insert Screw	Key
920-000-120	920-000-121	E02.5G SCLDR/L1.2 *	0.156	3.500	0.090	0.175	95.0	CDHB 1.20.60	MTS-183	T-6
920-000-124	920-000-125	E03H SCLDR/L1.2 *	0.187	4.000	0.102	0.205	95.0	CDHB 1.20.60	MTS-183	T-6
920-000-122	920-000-123	E03.5H SCLDR/L1.5 *	0.218	4.000	0.125	0.245	95.0	CDGW 1.510	MTS-184	T-6
920-000-127	920-000-129	E04H SCLDR/L1.5 *	0.250	4.000	0.172	0.312	95.0	CDGW 1.510	MTS-184	T-6
920-000-137	920-000-139	E05K SCLPR/L1.8 *	0.312	5.000	0.219	0.395	95.0	CPMT 1.81.20.5	MTS 224	T-7
920-000-151	920-000-153	E06M SCLPR/L2	0.375	6.000	0.250	0.460	95.0	CPMT 21.51	MTS-255	T-7
920-000-183	920-000-186	E08J SCLPR/L2	0.500	4.500	0.312	0.600	95.0	CPMT 21.51	MTS-255	T-7
920-000-219	920-000-222	E08R SCLPR/L2	0.500	8.000	0.312	0.600	95.0	CPMT 21.51	MTS-255	T-7
920-000-254	920-000-256	E10Q SCLPR/L2	0.625	7.000	0.406	0.770	95.0	CPMT 21.51	MTS-255	T-7
920-000-279	920-000-281	E10S SCLPR/L2	0.625	10.000	0.406	0.770	95.0	CPMT 21.51	MTS-255	T-7
920-000-185	920-000-188	E08J SCLPR/L3	0.500	4.500	0.344	0.625	95.0	CPMT 32.51	MTS-35	T-15
920-000-221	920-000-224	E08R SCLPR/L3	0.500	8.000	0.344	0.625	95.0	CPMT 32.51	MTS-35	T-15
920-000-255	920-000-257	E10Q SCLPR/L3	0.625	7.000	0.406	0.760	95.0	CPMT 32.51	MTS-35	T-15
920-000-280	920-000-282	E10S SCLPR/L3	0.625	10.000	0.406	0.760	95.0	CPMT 32.51	MTS-35	T-15
920-000-307	920-000-309	E12Q SCLPR/L3	0.750	7.000	0.500	0.920	95.0	CPMT 32.51	MTS-35	T-15
920-000-334	920-000-335	E12S SCLPR/L3	0.750	10.000	0.500	0.920	95.0	CPMT 32.51	MTS-35	T-15
920-000-364	920-000-365	E16R SCLPR/L3	1.000	8.000	0.625	1.185	95.0	CPMT 32.51	MTS-35	T-15
920-000-394	920-000-395	E16T SCLPR/L3	1.000	12.000	0.625	1.185	95.0	CPMT 32.51	MTS-35	T-15

Minimum Clearance

Coolant Thru

PRODUCT # Left hand	PRODUCT # Right hand	Designation	DCON MS	LF	WF	DMIN	KAPR	Insert	Insert Screw	Key
920-000-128	920-000-130	E04H SCLDR/L1.5-138 *	0.250	4.000	0.138	0.270	95.0	CDGW 1.510	MTS-184	T-6
920-000-138	920-000-140	E05K SCLPR/L1.8-167 *	0.312	5.000	0.167	0.340	95.0	CPMT 1.81.20.5	MTS 224	T-7
920-000-152	920-000-154	E06M SCLPR/L2-203	0.375	6.000	0.203	0.410	95.0	CPMT 21.51	MTS-255	T-7
920-000-184	920-000-187	E08J SCLPR/L2-281	0.500	4.500	0.281	0.560	95.0	CPMT 21.51	MTS-255	T-7
920-000-220	920-000-223	E08R SCLPR/L2-281	0.500	8.000	0.281	0.560	95.0	CPMT 21.51	MTS-255	T-7

Minimum Clearance Bars are intended for light machining with minimum bore clearance. Max depth of cut .015" - .020"
*bars .312 and smaller do not have flats

PRODUCT #	Insert Screws
968-000-086	MTS-183
968-000-087	MTS-184
968-000-088	MTS-2
968-000-091	MTS-224
968-000-092	MTS-255
968-000-094	MTS-35
968-000-090	MTS-2.5L
968-000-052	ETS 4-40

PRODUCT #	Key
968-000-156	T-6
968-000-158	T-7
968-000-149	T-10
968-000-151	T-15
968-000-153	T-20

PACKAGE SIZE OF 5

PACKAGE SIZE OF 5



by **Ultra-Dex**

CARBIDE

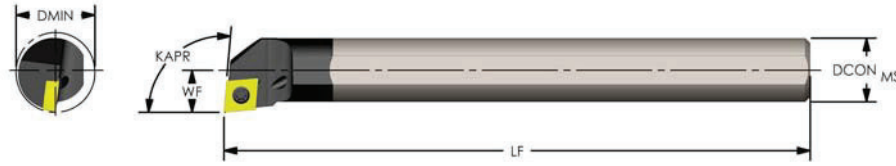

Positive 80° Diamond (KAPR: 95°)

Coolant Thru

PRODUCT # Left hand	PRODUCT # Right hand	Designation	DCON MS	LF	WF	DMIN	KAPR	Insert	Insert Screw	Key
920-000-147	920-000-149	E06M SCLCR/L2	0.375	6.000	0.250	0.460	95.0	CCMT 21.51	MTS-255	T-7
920-000-177	920-000-180	E08J SCLCR/L2	0.500	4.500	0.312	0.600	95.0	CCMT 21.51	MTS-255	T-7
920-000-213	920-000-216	E08R SCLCR/L2	0.500	8.000	0.312	0.600	95.0	CCMT 21.51	MTS-255	T-7
920-000-250	920-000-252	E10Q SCLCR/L2	0.625	7.000	0.406	0.760	95.0	CCMT 21.51	MTS-255	T-7
920-000-275	920-000-277	E10S SCLCR/L2	0.625	10.00	0.406	0.760	95.0	CCMT 21.51	MTS-255	T-7
920-000-179	920-000-182	E08J SCLCR/L3	0.500	4.500	0.344	0.625	95.0	CCMT 32.51	MTS-35	T-15
920-000-215	920-000-218	E08R SCLCR/L3	0.500	8.000	0.344	0.625	95.0	CCMT 32.51	MTS-35	T-15
920-000-251	920-000-253	E10Q SCLCR/L3	0.625	7.000	0.406	0.760	95.0	CCMT 32.51	MTS-35	T-15
920-000-276	920-000-278	E10S SCLCR/L3	0.625	10.00	0.406	0.760	95.0	CCMT 32.51	MTS-35	T-15
920-000-306	920-000-307	E12Q SCLCR/L3	0.750	7.000	0.500	0.920	95.0	CCMT 32.51	MTS-35	T-15
920-000-332	920-000-333	E12S SCLCR/L3	0.750	10.00	0.500	0.920	95.0	CCMT 32.51	MTS-35	T-15
920-000-362	920-000-363	E16R SCLCR/L3	1.000	8.000	0.625	1.185	95.0	CCMT 32.51	MTS-35	T-15
920-000-392	920-000-393	E16T SCLCR/L3	1.000	12.00	0.625	1.185	95.0	CCMT 32.51	MTS-35	T-15
920-000-417	920-000-419	E20U SCLCR/L3	1.250	14.00	0.765	1.465	95.0	CCMT 32.51	MTS-35	T-15
920-000-418	920-000-420	E20U SCLCR/L4	1.250	14.00	0.765	1.465	95.0	CCMT 432	MTS-4	T-20
920-000-426	920-000-427	E24U SCLCR/L4	1.500	14.00	0.890	1.730	95.0	CCMT 432	MTS-4	T-20

Minimum Clearance

Coolant Thru

PRODUCT # Left hand	PRODUCT # Right hand	Designation	DCON MS	LF	WF	DMIN	KAPR	Insert	Insert Screw	Key
920-000-148	920-000-150	E06M SCLCR/L2-203	0.375	6.000	0.203	0.410	95.0	CCMT 21.51	MTS-255	T-7
920-000-178	920-000-181	E08J SCLCR/L2-281	0.500	4.500	0.281	0.560	95.0	CCMT 21.51	MTS-255	T-7
920-000-214	920-000-217	E08R SCLCR/L2-281	0.500	8.000	0.281	0.560	95.0	CCMT 21.51	MTS-255	T-7

Minimum Clearance Bars are intended for light machining with minimum bore clearance. Max depth of cut .015" - .020"

USE THE RIGHT SET SCREW FLAT POINT, NOT CUP POINT

PRODUCT #	Insert Screws
968-000-086	MTS-183
968-000-087	MTS-184
968-000-088	MTS-2
968-000-091	MTS-224
968-000-092	MTS-255
968-000-094	MTS-35
968-000-090	MTS-2.5L
968-000-052	ETS 4-40

PACKAGE SIZE OF 5

PRODUCT #	Key
968-000-156	T-6
968-000-158	T-7
968-000-149	T-10
968-000-151	T-15
968-000-153	T-20

PACKAGE SIZE OF 5

CARBIDE



Positive 80° Diamond (KAPR: 97°) SERIES "C"

8:1 Ratio
Coolant Thru

PRODUCT #	Designation	DCON MS	LF	WF	DMIN	KAPR	Insert	Insert Screw	Key
915-000-001	CCUD-165/156-6-7R *	0.156	6.000	0.095	0.180	97.0	CDHB 1.20.60.5	MTS-183	T-6

* bars .312 and smaller do not have flats

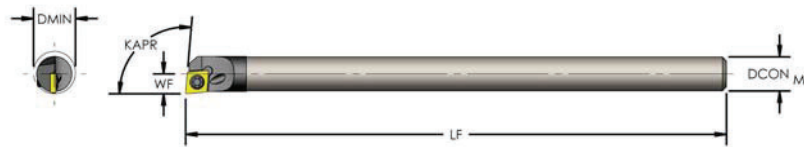

Positive 80° Diamond (KAPR: 95°) SERIES "C"

8:1 Ratio
Coolant Thru

PRODUCT #	Designation	DCON MS	LF	WF	DMIN	KAPR	Insert	Insert Screw	Key
915-000-002	CCUD-180/187-4-5R *	0.187	4.000	0.104	0.208	95.0	CDHB 1.20.60.5	MTS-183	T-6
915-000-003	CCUD-180/187-6-5R *	0.187	6.000	0.104	0.208	95.0	CDHB 1.20.60.5	MTS-183	T-6
915-000-006	CCUD-187-4-5R *	0.187	4.000	0.111	0.222	95.0	CDHB 1.20.60.5	MTS-183	T-6
915-000-007	CCUD-187-6-5R *	0.187	6.000	0.111	0.222	95.0	CDHB 1.20.60.5	MTS-183	T-6
915-000-011	CCUD-250-4-5R *	0.250	4.000	0.145	0.285	95.0	CDHB 1.20.60.5	MTS-184	T-6
915-000-013	CCUD-250-6-5R *	0.250	6.000	0.145	0.285	95.0	CDHB 1.20.60.5	MTS-184	T-6
915-000-014	CCUD-312-5-5R *	0.312	5.000	0.185	0.360	95.0	CDHB 1.20.60.5	MTS-184	T-6
915-000-012	CCUD-250-4-5R-1.5 *	0.250	4.000	0.145	0.285	95.0	CDGW 1.510	MTS-184	T-6

* bars .312 and smaller do not have flats

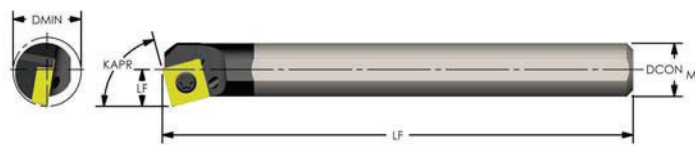

Positive Square (KAPR: 75°)

8:1 Ratio
Coolant Thru

PRODUCT #	Designation	DCON MS	LF	WF	DMIN	KAPR	Insert	Insert Screw	Key
920-000-230	E08R SSKCR3	0.500	8.000	0.344	0.625	75.0	SCMT 32.51	MTS-35	T-15
920-000-288	E10S SSKCR3	0.625	10.00	0.406	0.760	75.0	SCMT 32.51	MTS-35	T-15

USE THE RIGHT SET SCREW FLAT POINT, NOT CUP POINT

PRODUCT #	Insert Screws
968-000-086	MTS-183
968-000-087	MTS-184
968-000-088	MTS-2
968-000-091	MTS-224
968-000-092	MTS-255
968-000-094	MTS-35
968-000-090	MTS-2.5L
968-000-052	ETS 4-40

PACKAGE SIZE OF 5

PRODUCT #	Key
968-000-156	T-6
968-000-158	T-7
968-000-149	T-10
968-000-151	T-15
968-000-153	T-20

PACKAGE SIZE OF 5



by **Ultra-Dex**

CARBIDE

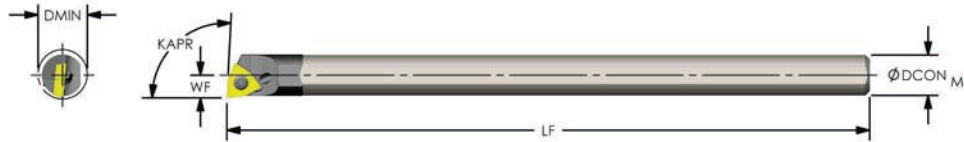

Positive Trigon (KAPR: 93°) SERIES "G, Q, S"

**8:1 Ratio
Coolant Thru**

PRODUCT # Left hand	PRODUCT # Right hand	Designation	DCON MS	LF	WF	DMIN	KAPR	Insert	Insert Screw	Key
915-000-053	915-000-054	GCUDW-187-6-3R/L	0.187	6.000	0.126	0.260	93.0	WPGT 1.511	MTS-184	T-6
915-000-055	915-000-056	GCUDW-250-6-3R/L	0.250	6.000	0.143	0.285	93.0	WPGT 1.511	MTS-184	T-6
915-000-057	915-000-058	GCUDW-312-6-3R/L	0.312	6.000	0.174	0.374	93.0	WPGT 1.511	MTS-184	T-6
915-000-068	915-000-069	QCUDW-375-6-3R/L	0.375	6.000	0.211	0.415	93.0	WPGT 21.50	MTS-255	T-7
915-000-070	915-000-071	QCUDW-500-8-3R/L	0.500	8.000	0.273	0.540	93.0	WPGT 21.50	MTS-255	T-7
N/A	915-000-090	SCUDW-625-10-3R	0.625	10.000	0.345	0.675	93.0	WPMT 32.51	MTS-35	T-15
N/A	915-000-091	SCUDW-750-10-3R	0.750	10.000	0.407	0.800	93.0	WPMT 32.51	MTS-35	T-15

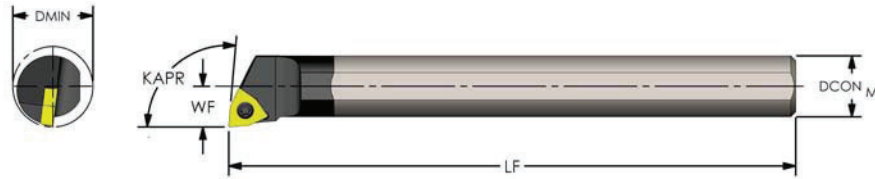

Positive Trigon (KAPR: 95°)

**8:1 Ratio
No Coolant**

PRODUCT # Left hand	PRODUCT # Right hand	Designation	DCON MS	LF	WF	DMIN	KAPR	Insert	Insert Screw	Key
N/A	920-000-007	C03H SWLCR1.2 *	0.187	4.000	0.102	0.205	95.0	WCMT 1.210.5	MTS-183	T-6
N/A	920-000-016	C04H SWLCR1.2 *	0.250	4.000	0.172	0.312	95.0	WCMT 1.210.5	MTS-184	T-6
N/A	920-000-026	C05K SWLCR1.5 *	0.312	5.000	0.219	0.395	95.0	WCMT 1.51.50.5	MTS-2	T-6
920-000-052	920-000-054	C06M SWLCR/L2	0.375	6.000	0.250	0.460	95.0	WCMT 21.51	MTS-255	T-7
920-000-084	920-000-086	C08J SWLCR/L2	0.500	4.500	0.312	0.600	95.0	WCMT 21.51	MTS-255	T-7
920-000-116	920-000-118	C08R SWLCR/L2	0.500	8.000	0.312	0.600	95.0	WCMT 21.51	MTS-255	T-7

Minimum Clearance

No Coolant

PRODUCT # Left hand	PRODUCT # Right hand	Designation	DCON MS	LF	WF	DMIN	KAPR	Insert	Insert Screw	Key
N/A	920-000-017	C04H SWLCR1.2-138 *	0.250	4.000	0.138	0.275	95.0	WCMT 1.210.5	MTS-184	T-6
N/A	920-000-027	C05K SWLCR1.5-167 *	0.312	5.000	0.167	0.345	95.0	WCMT 1.51.50.5	MTS-2	T-6
920-000-053	920-000-055	C06M SWLCR/L2-203	0.375	6.000	0.203	0.400	95.0	WCMT 21.51	MTS-255	T-7
920-000-085	920-000-087	C08J SWLCR/L2-281	0.500	4.500	0.281	0.560	95.0	WCMT 21.51	MTS-255	T-7
920-000-117	920-000-119	C08R SWLCR/L2-281	0.500	8.000	0.281	0.560	95.0	WCMT 21.51	MTS-255	T-7

Minimum Clearance Bars are intended for light machining with minimum bore clearance Max depth of cut .015" - .020"
* bars .312 and smaller do not have flats

USE THE RIGHT SET SCREW FLAT POINT, NOT CUP POINT

CARBIDE

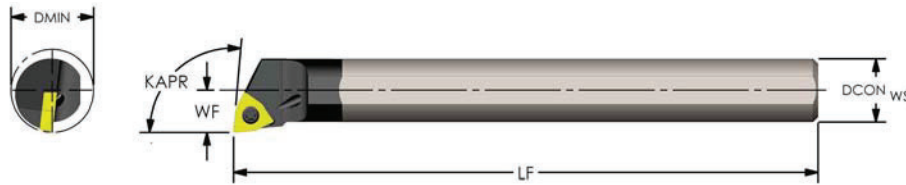

Positive Trigon (KAPR: 95°)

8:1 Ratio
Coolant Thru

PRODUCT # Left hand	PRODUCT # Right hand	Designation	DCON MS	LF	WF	DMIN	KAPR	Insert	Insert Screw	Key
N/A	920-000-126	E03H SWLCR1.2 *	0.187	4.000	0.102	0.205	95.0	WCMT 1.210.5	MTS-183	T-6
N/A	920-000-135	E04H SWLCR1.2 *	0.250	4.000	0.172	0.395	95.0	WCMT 1.210.5	MTS-184	T-6
N/A	920-000-145	E05K SWLCR1.5 *	0.312	5.000	0.219	0.410	95.0	WCMT1.51.50.5	MTS-2	T-6
920-000-173	920-000-175	E06M SWLCR/L2	0.375	6.000	0.250	0.460	95.0	WCMT 21.51	MTS-255	T-7
920-000-205	920-000-207	E08J SWLCR/L2	0.500	4.500	0.312	0.600	95.0	WCMT 21.51	MTS-255	T-7
920-000-244	920-000-246	E08R SWLCR/L2	0.500	8.000	0.312	0.600	95.0	WCMT 21.51	MTS-255	T-7
920-000-269	920-000-271	E10Q SWLCR/L2	0.625	7.000	0.406	0.760	95.0	WCMT 21.51	MTS-255	T-7
920-000-296	920-000-298	E10S SWLCR/L2	0.625	10.000	0.406	0.760	95.0	WCMT 21.51	MTS-255	T-7
920-000-270	920-000-272	E10Q SWLCR/L3	0.625	7.000	0.406	0.760	95.0	WCMT 32.51	MTS-35	T-15
920-000-297	920-000-299	E10S SWLCR/L3	0.625	10.000	0.406	0.760	95.0	WCMT 32.51	MTS-35	T-15
920-000-322	920-000-323	E12Q SWLCR/L3	0.750	7.000	0.500	0.920	95.0	WCMT 32.51	MTS-35	T-15
920-000-350	920-000-351	E12S SWLCR/L3	0.750	10.000	0.500	0.920	95.0	WCMT 32.51	MTS-35	T-15
920-000-378	920-000-379	E16R SWLCR/L3	1.000	8.000	0.625	1.185	95.0	WCMT 32.51	MTS-35	T-15
920-000-408	920-000-409	E16T SWLCR/L3	1.000	12.000	0.625	1.185	95.0	WCMT 32.51	MTS-35	T-15

Minimum Clearance

Coolant Thru

PRODUCT # Left hand	PRODUCT # Right hand	Designation	DCON MS	LF	WF	DMIN	KAPR	Insert	Insert Screw	Key
N/A	920-000-136	E04H SWLCR1.2-138 *	0.250	4.000	0.138	0.275	95.0	WCMT 1.210.5	MTS-184	T-6
N/A	920-000-146	E05K SWLCR1.5-167 *	0.312	5.000	0.167	0.345	95.0	WCMT 1.51.50.5	MTS-2	T-6
920-000-174	920-000-176	E06M SWLCR/L2-203	0.375	6.000	0.203	0.410	95.0	WCMT 21.51	MTS-255	T-7
920-000-206	920-000-208	E08J SWLCR/L2-281	0.500	4.500	0.281	0.560	95.0	WCMT 21.51	MTS-255	T-7
920-000-245	920-000-247	E08R SWLCR/L2-281	0.500	8.000	0.281	0.560	95.0	WCMT 21.51	MTS-255	T-7

Minimum Clearance Bars are intended for light machining with minimum bore clearance Max depth of cut .015" - .020"
* bars .312 and smaller do not have flats

USE THE RIGHT SET SCREW FLAT POINT, NOT CUP POINT

PRODUCT #	Insert Screws
968-000-086	MTS-183
968-000-087	MTS-184
968-000-088	MTS-2
968-000-091	MTS-224
968-000-092	MTS-255
968-000-094	MTS-35
968-000-090	MTS-2.5L
968-000-052	ETS 4-40

PACKAGE SIZE OF 5

PRODUCT #	Key
968-000-156	T-6
968-000-158	T-7
968-000-149	T-10
968-000-151	T-15
968-000-153	T-20

PACKAGE SIZE OF 5



CARBIDE

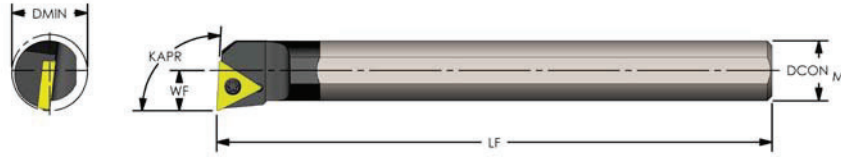

Positive Triangle (KAPR: 93°)

**8:1 Ratio
No Coolant**

PRODUCT # Left hand	PRODUCT # Right hand	Designation	DCON MS	LF	WF	DMIN	KAPR	Insert	Insert Screw	Key
920-000-012	920-000-014	C04H STUCR/L1.2 *	0.250	4.000	0.172	0.312	93.0	TCMT 1.21.20.5	MTS-184	T-6
920-000-022	920-000-024	C05K STUCR/L1.2 *	0.312	5.000	0.219	0.395	93.0	TCMT 1.21.20.5	MTS-184	T-6
920-000-044	920-000-046	C06M STUCR/L2	0.375	6.000	0.250	0.460	93.0	TCMT 21.51	MTS-255	T-7
920-000-076	920-000-078	C08J STUCR/L2	0.500	4.500	0.312	0.600	93.0	TCMT 21.51	MTS-255	T-7
920-000-108	920-000-110	C08R STUCR/L2	0.500	8.000	0.312	0.600	93.0	TCMT 21.51	MTS-255	T-7
920-000-048	920-000-050	C06M STUPR/L2	0.375	6.000	0.250	0.460	93.0	TPMT 21.51	MTS-255	T-7
920-000-080	920-000-082	C08J STUPR/L2	0.500	4.500	0.312	0.600	93.0	TPMT 21.51	MTS-255	T-7
920-000-112	920-000-114	C08R STUPR/L2	0.500	8.000	0.312	0.600	93.0	TPMT 21.51	MTS-255	T-7

Minimum Clearance

No Coolant

PRODUCT # Left hand	PRODUCT # Right hand	Designation	DCON MS	LF	WF	DMIN	KAPR	Insert	Insert Screw	Key
920-000-013	920-000-015	C04H STUCR/L1.2-138 *	0.250	4.000	0.138	0.275	93.0	TCMT 1.21.20.5	MTS-184	T-6
920-000-023	920-000-025	C05K STUCR/L1.2-167 *	0.312	5.000	0.167	0.340	93.0	TCMT 1.21.20.5	MTS-184	T-6
920-000-045	920-000-047	C06M STUCR/L2-203	0.375	6.000	0.203	0.410	93.0	TCMT 21.51	MTS-255	T-7
920-000-077	920-000-079	C08J STUCR/L2-281	0.500	4.500	0.281	0.560	93.0	TCMT 21.51	MTS-255	T-7
920-000-109	920-000-111	C08R STUCR/L2-281	0.500	8.000	0.281	0.570	93.0	TCMT 21.51	MTS-255	T-7
920-000-049	920-000-051	C06M STUPR/L2-203	0.375	6.000	0.203	0.410	93.0	TPMT 21.51	MTS-255	T-7
920-000-081	920-000-083	C08J STUPR/L2-281	0.500	4.500	0.281	0.560	93.0	TPMT 21.51	MTS-255	T-7
920-000-113	920-000-115	C08R STUPR/L2-281	0.500	8.000	0.281	0.560	93.0	TPMT 21.51	MTS-255	T-7

Minimum Clearance Bars are intended for light machining with minimum bore clearance Max depth of cut .015" - .020"
* bars .312 and smaller do not have flats

USE THE RIGHT SET SCREW FLAT POINT, NOT CUP POINT

PRODUCT #	Insert Screws
968-000-086	MTS-183
968-000-087	MTS-184
968-000-088	MTS-2
968-000-091	MTS-224
968-000-092	MTS-255
968-000-094	MTS-35
968-000-090	MTS-2.5L
968-000-052	ETS 4-40

PACKAGE SIZE OF 5

PRODUCT #	Key
968-000-156	T-6
968-000-158	T-7
968-000-149	T-10
968-000-151	T-15
968-000-153	T-20

PACKAGE SIZE OF 5

CARBIDE

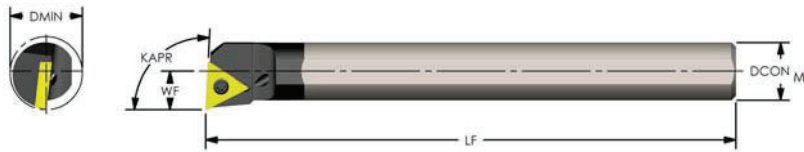

Positive Triangle (KAPR: 93°)

8:1 Ratio

Coolant Thru

PRODUCT # Left hand	PRODUCT # Right hand	Designation	DCON MS	LF	WF	DMIN	KAPR	Insert	Insert Screw	Key
920-000-131	920-000-133	E04H STUCR/L1.2 *	0.250	4.000	0.172	0.312	93.0	TCMT 1.21.20.5	MTS-184	T-6
920-000-141	920-000-143	E05K STUCR/L1.2 *	0.312	5.000	0.219	0.395	93.0	TCMT 1.21.20.5	MTS-184	T-6
920-000-164	920-000-166	E06M STUCR/L2	0.375	6.000	0.250	0.460	93.0	TCMT 21.51	MTS-255	T-7
920-000-197	920-000-199	E08J STUCR/L2	0.500	4.500	0.312	0.600	93.0	TCMT 21.51	MTS-255	T-7
920-000-235	920-000-237	E08R STUCR/L2	0.500	8.000	0.312	0.600	93.0	TCMT 21.51	MTS-255	T-7
920-000-265	920-000-266	E10Q STUCR/L2	0.625	7.000	0.406	0.760	93.0	TCMT 21.51	MTS-255	T-7
920-000-291	920-000-292	E10S STUCR/L2	0.625	10.000	0.406	0.760	93.0	TCMT 21.51	MTS-255	T-7
920-000-318	920-000-319	E12Q STUCR/L3	0.750	7.000	0.500	0.920	93.0	TCMT 32.51	MTS-35	T-15
920-000-345	920-000-346	E12S STUCR/L3	0.750	10.000	0.500	0.920	93.0	TCMT 32.51	MTS-35	T-15
920-000-374	920-000-375	E16R STUCR/L3	1.000	8.000	0.625	1.185	93.0	TCMT 32.51	MTS-35	T-15
920-000-404	920-000-405	E16T STUCR/L3	1.000	12.000	0.625	1.185	93.0	TCMT 32.51	MTS-35	T-15
920-000-168	920-000-170	E06M STUPR/L2	0.375	6.000	0.250	0.460	93.0	TPMT 21.51	MTS-255	T-7
920-000-201	920-000-203	E08J STUPR/L2	0.500	4.500	0.312	0.600	93.0	TPMT 21.51	MTS-255	T-7
920-000-239	920-000-241	E08R STUPR/L2	0.500	8.000	0.312	0.600	93.0	TPMT 21.51	MTS-255	T-7
920-000-267	920-000-268	E10Q STUPR/L2	0.625	7.000	0.406	0.760	93.0	TPMT 21.51	MTS-255	T-7
920-000-293	920-000-294	E10S STUPR/L2	0.625	10.000	0.406	0.760	93.0	TPMT 21.51	MTS-255	T-7
920-000-320	920-000-321	E12Q STUPR/L3	0.750	7.000	0.500	0.920	93.0	TPMT 32.51	MTS-35	T-15
920-000-347	920-000-348	E12S STUPR/L3	0.750	10.000	0.500	0.920	93.0	TPMT 32.51	MTS-35	T-15
920-000-376	920-000-377	E16R STUPR/L3	1.000	8.000	0.625	1.185	93.0	TPMT 32.51	MTS-35	T-15
920-000-406	920-000-407	E16T STUPR/L3	1.000	12.000	0.625	1.185	93.0	TPMT 32.51	MTS-35	T-15

Minimum Clearance

Coolant Thru

PRODUCT # Left hand	PRODUCT # Right hand	Designation	DCON MS	LF	WF	DMIN	KAPR	Insert	Insert Screw	Key
920-000-132	920-000-134	E04H STUCR/L1.2-138 *	0.250	4.000	0.138	0.275	93.0	TCMT 1.21.20.5	MTS-184	T-6
920-000-142	920-000-144	E05K STUCR/L1.2-167 *	0.312	5.000	0.167	0.340	93.0	TCMT 1.21.20.5	MTS-184	T-6
920-000-165	920-000-167	E06M STUCR/L2-203	0.375	6.000	0.203	0.410	93.0	TCMT 21.51	MTS-255	T-7
920-000-198	920-000-200	E08J STUCR/L2-281	0.500	4.500	0.281	0.560	93.0	TCMT 21.51	MTS-255	T-7
920-000-236	920-000-238	E08R STUCR/L2-281	0.500	8.000	0.281	0.560	93.0	TCMT 21.51	MTS-255	T-7
920-000-169	920-000-170	E06M STUPR/L2-203	0.375	6.000	0.203	0.410	93.0	TPMT 21.51	MTS-255	T-7
920-000-202	920-000-204	E08J STUPR/L2-281	0.500	4.500	0.281	0.560	93.0	TPMT 21.51	MTS-255	T-7
920-000-240	920-000-242	E08R STUPR/L2-281	0.500	8.000	0.281	0.560	93.0	TPMT 21.51	MTS-255	T-7

Minimum Clearance Bars are intended for light machining with minimum bore clearance Max depth of cut .015" - .020"
* bars .312 and smaller do not have flats

USE THE RIGHT SET SCREW FLAT POINT, NOT CUP POINT



CARBIDE

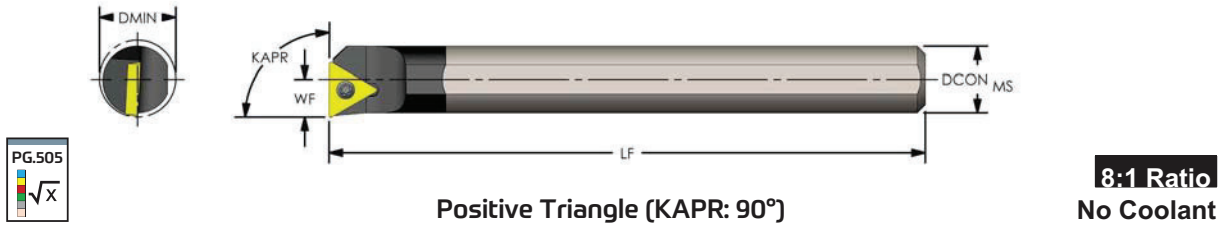

Positive Triangle (KAPR: 90°)

8:1 Ratio
No Coolant

PRODUCT #	Designation	DCON MS	LF	WF	DMIN	KAPR	Insert	Insert Screw	Key
920-000-042	C06M STFPR2	0.375	6.000	0.250	0.460	90.0	TPMT 21.51	MTS-255	T-7
920-000-074	C08J STFPR2	0.500	4.500	0.312	0.600	90.0	TPMT 21.51	MTS-255	T-7
920-000-106	C08R STFPR2	0.500	8.000	0.312	0.600	90.0	TPMT 21.51	MTS-255	T-7
920-000-040	C06M STFPCR2	.375	6.000	0.250	0.460	90.0	TCMT 21.51	MTS-255	T-7
920-000-072	C08J STFPCR2	0.500	4.500	0.312	0.600	90.0	TCMT 21.51	MTS-255	T-7
920-000-104	C08R STFPCR2	0.500	8.000	0.312	0.600	90.0	TCMT 21.51	MTS-255	T-7

Minimum Clearance

No Coolant

PRODUCT #	Designation	DCON MS	LF	WF	DMIN	KAPR	Insert	Insert Screw	Key
920-000-043	C06M STFPR2-203	0.375	6.000	0.203	0.410	90.0	TPMT 21.51	MTS-255	T-7
920-000-075	C08J STFPR2-281	0.500	4.500	0.281	0.560	90.0	TPMT 21.51	MTS-255	T-7
920-000-107	C08R STFPR2-281	0.500	8.000	0.281	0.560	90.0	TPMT 21.51	MTS-255	T-7
920-000-041	C06M STFPCR2-203	0.375	6.000	0.203	0.410	90.0	TCMT 21.51	MTS-255	T-7
920-000-073	C08J STFPCR2-281	0.500	4.500	0.281	0.560	90.0	TCMT 21.51	MTS-255	T-7
920-000-105	C08R STFPCR2-281	0.500	8.000	0.281	0.560	90.0	TCMT 21.51	MTS-255	T-7

Minimum Clearance Bars are intended for light machining with minimum bore clearance. Max depth of cut .015" - .020"

USE THE RIGHT SET SCREW FLAT POINT, NOT CUP POINT

PRODUCT #	Insert Screws
968-000-086	MTS-183
968-000-087	MTS-184
968-000-088	MTS-2
968-000-091	MTS-224
968-000-092	MTS-255
968-000-094	MTS-35
968-000-090	MTS-2.5L
968-000-052	ETS 4-40

PACKAGE SIZE OF 5

PRODUCT #	Key
968-000-156	T-6
968-000-158	T-7
968-000-149	T-10
968-000-151	T-15
968-000-153	T-20

PACKAGE SIZE OF 5

CARBIDE

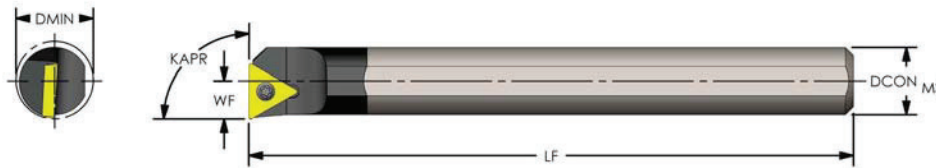

Positive Triangle (KAPR: 90°)

8:1 Ratio
Coolant Thru

PRODUCT #	Designation	DCON MS	LF	WF	DMIN	KAPR	Insert	Insert Screw	Key
920-000-162	E06M STFPR2	0.375	6.000	0.250	0.460	90.0	TPMT 21.51	MTS-255	T-7
920-000-195	E08J STFPR2	0.500	4.500	0.312	0.600	90.0	TPMT 21.51	MTS-255	T-7
920-000-233	E08R STFPR2	0.500	8.000	0.312	0.600	90.0	TPMT 21.51	MTS-255	T-7
920-000-264	E10Q STFPR2	0.625	7.000	0.406	0.760	90.0	TPMT 21.51	MTS-255	T-7
920-000-290	E10S STFPR2	0.625	10.000	0.406	0.760	90.0	TPMT 21.51	MTS-255	T-7
920-000-317	E12Q STFPR3	0.750	7.000	0.500	0.920	90.0	TPMT 32.51	MTS-35	T-15
920-000-344	E12S STFPR3	0.750	10.000	0.500	0.920	90.0	TPMT 32.51	MTS-35	T-15
920-000-373	E16R STFPR3	1.000	8.000	0.625	1.185	90.0	TPMT 32.51	MTS-35	T-15
920-000-403	E16T STFPR3	1.000	12.000	0.625	1.185	90.0	TPMT 32.51	MTS-35	T-15
920-000-160	E06M STFPCR2	0.375	6.000	0.250	0.460	90.0	TCMT 21.51	MTS-255	T-7
920-000-193	E08J STFPCR2	0.500	4.500	0.312	0.600	90.0	TCMT 21.51	MTS-255	T-7
920-000-231	E08R STFPCR2	0.500	8.000	0.312	0.600	90.0	TCMT 21.51	MTS-255	T-7
920-000-263	E10Q STFPCR2	0.625	7.000	0.406	0.760	90.0	TCMT 21.51	MTS-255	T-7
920-000-289	E10S STFPCR2	0.625	10.000	0.406	0.760	90.0	TCMT 21.51	MTS-255	T-7
920-000-316	E12Q STFPCR3	0.750	7.000	0.500	0.920	90.0	TCMT 32.51	MTS-35	T-15
920-000-343	E12S STFPCR3	0.750	10.000	0.500	0.920	90.0	TCMT 32.51	MTS-35	T-15
920-000-372	E16R STFPCR3	1.000	8.000	0.625	1.185	90.0	TCMT 32.51	MTS-35	T-15
920-000-402	E16T STFPCR3	1.000	12.000	0.625	1.185	90.0	TCMT 32.51	MTS-35	T-15

Minimum Clearance

Coolant Thru

PRODUCT #	Designation	DCON MS	LF	WF	DMIN	KAPR	Insert	Insert Screw	Key
920-000-163	E06M STFPR2-203	0.375	6.000	0.203	0.410	90.0	TPMT 21.51	MTS-255	T-7
920-000-196	E08J STFPR2-281	0.500	4.500	0.281	0.560	90.0	TPMT 21.51	MTS-255	T-7
920-000-234	E08R STFPR2-281	0.500	8.000	0.281	0.560	90.0	TPMT 21.51	MTS-255	T-7
920-000-161	E06M STFPCR2-203	0.375	6.000	0.203	0.410	90.0	TCMT 21.51	MTS-255	T-7
920-000-194	E08J STFPCR2-281	0.500	4.500	0.281	0.560	90.0	TCMT 21.51	MTS-255	T-7
920-000-232	E08R STFPCR2-281	0.500	8.000	0.281	0.560	90.0	TCMT 21.51	MTS-255	T-7

Minimum Clearance Bars are intended for light machining with minimum bore clearance. Max depth of cut .015" - .020"

USE THE RIGHT SET SCREW FLAT POINT, NOT CUP POINT



CARBIDE

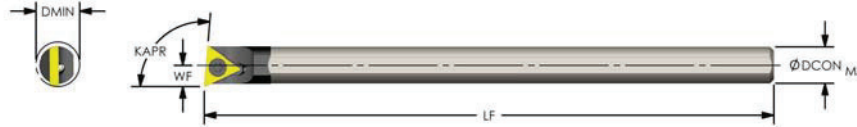

Positive Triangle (KAPR: 95°) SERIES "F, Q, S"

8:1 Ratio
Coolant Thru

PRODUCT #	Designation	DCON MS	LF	WF	DMIN	KAPR	Insert	Insert Screw	Key
915-000-030	FCUD-187-4-5R *	0.187	4.000	0.126	0.275	95.0	TDHB 1.280.750.5	MTS-224	T-7
915-000-031	FCUD-187-6-5R *	0.187	6.000	0.126	0.275	95.0	TDHB 1.280.750.5	MTS-224	T-7
915-000-034	FCUD-250-4-5R *	0.250	4.000	0.156	0.300	95.0	TDHB 1.280.750.5	MTS-224	T-7
915-000-035	FCUD-250-6-5R *	0.250	6.000	0.156	0.300	95.0	TDHB 1.280.750.5	MTS-224	T-7
915-000-038	FCUD-312-4-5R *	0.312	4.000	0.187	0.360	95.0	TDHB 1.280.750.5	MTS-224	T-7
915-000-039	FCUD-312-6-5R *	0.312	6.000	0.187	0.360	95.0	TDHB 1.280.750.5	MTS-224	T-7
915-000-066	QCUD-375-6-5R	0.375	6.000	0.228	0.438	95.0	TPCB 220.5	ETS 4-40	T-10
915-000-065	QCUD-375-10-5R	0.375	10.000	0.228	0.438	95.0	TPCB 220.5	ETS 4-40	T-10
915-000-067	QCUD-500-8-5R	0.500	8.000	0.296	0.563	95.0	TPCB 220.5	ETS 4-40	T-10
915-000-088	SCUD-625-6-5R	0.625	6.000	0.393	0.731	95.0	TD 320.5	ETS 4-40	T-10
915-000-087	SCUD-625-10-5R	0.625	10.000	0.393	0.731	95.0	TD 320.5	ETS 4-40	T-10
915-000-089	SCUD-750-10-5R	0.750	10.000	0.460	0.855	95.0	TD 320.5	ETS 4-40	T-10
915-000-086	SCUD-1000-12-5R	1.000	12.000	0.585	1.105	95.0	TD 320.5	ETS 4-40	T-10

*bars .312 and smaller do not have flats

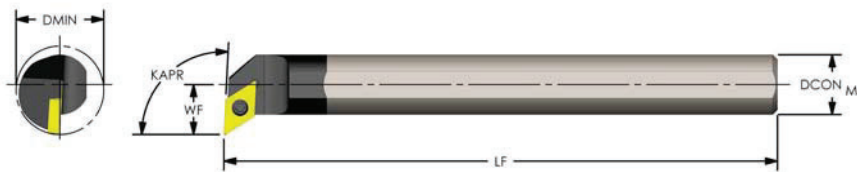

Positive 55° Diamond (KAPR: 93°) Profiling

8:1 Ratio
No Coolant

PRODUCT # Left hand	PRODUCT # Right hand	Designation	DCON MS	LF	WF	DMIN	KAPR	Insert	Insert Screw	Key
920-000-036	920-000-037	C06M SDUCR/L2	0.375	6.000	0.375	0.585	93.0	DCMT 21.51	MTS-255	T-7
920-000-068	920-000-069	C08J SDUCR/L2	0.500	4.500	0.437	0.720	93.0	DCMT 21.51	MTS-255	T-7
920-000-100	920-000-101	C08R SDUCR/L2	0.500	8.000	0.437	0.720	93.0	DCMT 21.51	MTS-255	T-7

USE THE RIGHT SET SCREW FLAT POINT, NOT CUP POINT

PRODUCT #	Insert Screws
968-000-086	MTS-183
968-000-087	MTS-184
968-000-088	MTS-2
968-000-091	MTS-224
968-000-092	MTS-255
968-000-094	MTS-35
968-000-090	MTS-2.5L
968-000-052	ETS 4-40

PACKAGE SIZE OF 5

PRODUCT #	Key
968-000-156	T-6
968-000-158	T-7
968-000-149	T-10
968-000-151	T-15
968-000-153	T-20

PACKAGE SIZE OF 5



Positive 55° Diamond (KAPR: 93°) Profiling

Coolant Thru

PRODUCT # Left hand	PRODUCT # Right hand	Designation	DCON MS	LF	WF	DMIN	KAPR	Insert	Insert Screw	Key
920-000-156	920-000-157	E06M SDUCR/L2	0.375	6.000	0.375	0.585	93.0	DCMT 21.51	MTS-255	T-7
920-000-189	920-000-190	E08J SDUCR/L2	0.500	4.500	0.437	0.720	93.0	DCMT 21.51	MTS-255	T-7
920-000-226	920-000-227	E08R SDUCR/L2	0.500	8.000	0.437	0.720	93.0	DCMT 21.51	MTS-255	T-7
920-000-259	920-000-260	E10Q SDUCR/L2	0.625	7.000	0.500	0.850	93.0	DCMT 21.51	MTS-255	T-7
920-000-284	920-000-285	E10S SDUCR/L2	0.625	10.000	0.500	0.850	93.0	DCMT 21.51	MTS-255	T-7
920-000-310	920-000-311	E12Q SDUCR/L3	0.750	7.000	0.625	1.050	93.0	DCMT 32.51	MTS-35	T-15
920-000-337	920-000-338	E12S SDUCR/L3	0.750	10.000	0.625	1.050	93.0	DCMT 32.51	MTS-35	T-15
920-000-366	920-000-367	E16R SDUCR/L3	1.000	8.000	0.750	1.310	93.0	DCMT 32.51	MTS-35	T-15
920-000-396	920-000-397	E16T SDUCR/L3	1.000	12.000	0.750	1.310	93.0	DCMT 32.51	MTS-35	T-15
920-000-312	920-000-313	E12Q SDUPR/L3	0.750	7.000	0.625	1.050	93.0	DPMT 32.51	MTS-35	T-15
920-000-339	920-000-340	E12S SDUPR/L3	0.750	10.000	0.625	1.050	93.0	DPMT 32.51	MTS-35	T-15
920-000-368	920-000-369	E16R SDUPR/L3	1.000	8.000	0.750	1.310	93.0	DPMT 32.51	MTS-35	T-15
920-000-398	920-000-399	E16T SDUPR/L3	1.000	12.000	0.750	1.310	93.0	DPMT 32.51	MTS-35	T-15

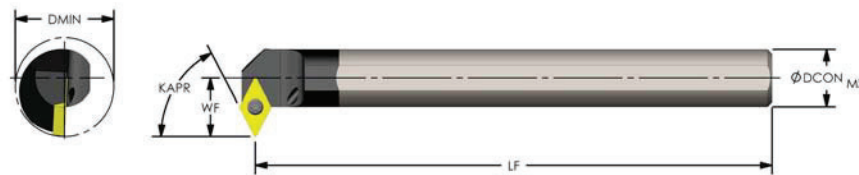

Positive 55° Diamond (KAPR: 62.5°) Profiling

8:1 Ratio
Coolant Thru

PRODUCT #	Designation	DCON MS	LF	WF	DMIN	KAPR	Insert	Insert Screw	Key
920-000-258	E10Q SDNCR2	0.625	6.86	.562	0.920	62.5	DCMT 21.51	MTS-255	T-7
920-000-336	E12S SDNCR3	0.750	9.80	0.765	1.190	62.5	DCMT 32.51	MTS-35	T-15

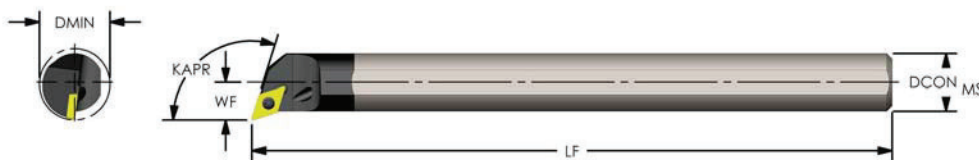

Positive 55° Diamond (KAPR: 107.5°) Profiling

8:1 Ratio
Coolant Thru

PRODUCT #	Designation	DCON MS	LF	WF	DMIN	KAPR	Insert	Insert Screw	Key
920-000-155	E06M SDQCR2	0.375	6.000	0.281	0.490	107.5	DCMT 21.51	MTS-255	T-7
920-000-225	E08R SDQCR2	0.500	8.000	0.341	0.620	107.5	DCMT 21.51	MTS-255	T-7
920-000-283	E10S SDQCR2	0.625	10.000	0.406	0.760	107.5	DCMT 21.51	MTS-255	T-7

USE THE RIGHT SET SCREW FLAT POINT, NOT CUP POINT



by **Ultra-Dex**

CARBIDE

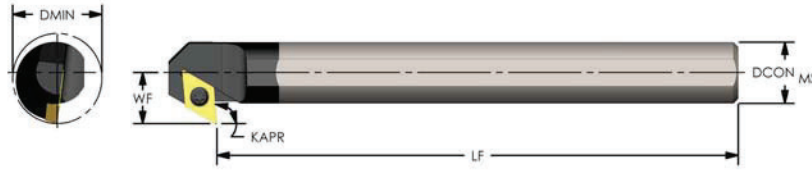

Positive 55° Diamond (KAPR: 95°) Back Facing

**8:1 Ratio
No Coolant**

PRODUCT # Left hand	PRODUCT # Right hand	Designation	DCON MS	LF	WF	DMIN	KAPR	Insert	Insert Screw	Key
920-000-038	920-000-039	C06M SDXCR/L2	0.375	6.000	0.375	0.585	95.0	DCMT 21.51	MTS-255	T-7
920-000-070	920-000-071	C08J SDXCR/L2	0.500	4.500	0.437	0.720	95.0	DCMT 21.51	MTS-255	T-7
920-000-102	920-000-103	C08R SDXCR/L2	0.500	8.000	0.437	0.720	95.0	DCMT 21.51	MTS-255	T-7

Coolant Thru

PRODUCT # Left hand	PRODUCT # Right hand	Designation	DCON MS	LF	WF	DMIN	KAPR	Insert	Insert Screw	Key
920-000-158	920-000-159	E06M SDXCR/L2	0.375	6.000	0.375	0.585	95.0	DCMT 21.51	MTS-255	T-7
920-000-191	920-000-192	E08J SDXCR/L2	0.500	4.500	0.437	0.720	95.0	DCMT 21.51	MTS-255	T-7
920-000-228	920-000-229	E08R SDXCR/L2	0.500	8.000	0.437	0.720	95.0	DCMT 21.51	MTS-255	T-7
920-000-261	920-000-262	E10Q SDXCR/L2	0.625	7.000	0.500	0.850	95.0	DCMT 21.51	MTS-255	T-7
920-000-286	920-000-287	E10S SDXCR/L2	0.625	10.000	0.500	0.850	95.0	DCMT 21.51	MTS-255	T-7
920-000-314	920-000-315	E12Q SDXCR/L3	0.750	7.000	0.625	1.050	95.0	DCMT 32.51	MTS-35	T-15
920-000-341	920-000-342	E12S SDXCR/L3	0.750	10.000	0.625	1.050	95.0	DCMT 32.51	MTS-35	T-15
920-000-370	920-000-371	E16R SDXCR/L3	1.000	8.000	0.750	1.310	95.0	DCMT 32.51	MTS-35	T-15
920-000-400	920-000-401	E16T SDXCR/L3	1.000	12.000	0.750	1.310	95.0	DCMT 32.51	MTS-35	T-15

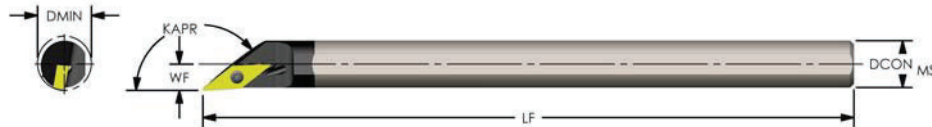

Positive 35° Diamond (KAPR: 142°) Profiling

**8:1 Ratio
Coolant Thru**

PRODUCT #	Designation	DCON MS	LF	WF	DMIN	KAPR	Insert	Insert Screw	Key
920-000-172	E06M SVJBR2	0.375	6.000	0.223	0.445	142.0	VBMT 21.51	MTS-2.5L	T-7
920-000-243	E08R SVJBR2	0.500	8.000	0.285	0.570	142.0	VBMT 21.51	MTS-2.5L	T-7
920-000-295	E10S SVJBR2	0.625	10.000	0.348	0.700	142.0	VBMT 21.51	MTS-2.5L	T-7
920-000-349	E12S SVJBR3	0.750	10.000	0.421	0.840	142.0	VBMT 331	MTS-3.5L	T-15

PRODUCT #	Insert Screws
968-000-086	MTS-183
968-000-087	MTS-184
968-000-088	MTS-2
968-000-091	MTS-224
968-000-092	MTS-255
968-000-094	MTS-35
968-000-090	MTS-2.5L
968-000-052	ETS 4-40

PRODUCT #	Key
968-000-156	T-6
968-000-158	T-7
968-000-149	T-10
968-000-151	T-15
968-000-153	T-20

PACKAGE SIZE OF 5

PACKAGE SIZE OF 5

CARBIDE

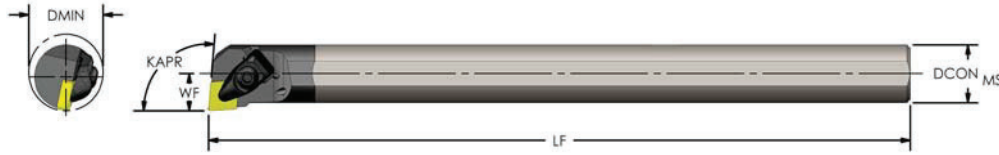

Negative 80° Diamond (KAPR: 95°) Shank

8:1 Ratio
Coolant Thru

PRODUCT #	Designation	DCON MS	LF	WF	DMIN	KAPR	Insert	Shim	Shim Screw	Clamp Assy.
920-000-380	E16T DCLNR4	1.000	12.000	0.640	1.200	95.0	CNMG 432	N/A	N/A	PB4-CA
920-000-410	E20U DCLNR4	1.250	14.000	0.765	1.470	95.0	CNMG 432	ICSN 433	PB4-SS	PB4-CA

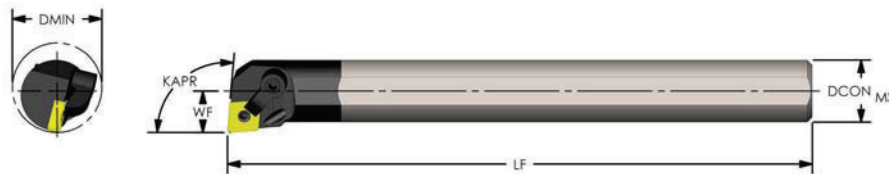

Negative 80° Diamond (KAPR: 95°)

8:1 Ratio
Coolant Thru

PRODUCT # Left hand	PRODUCT # Right hand	Designation	DCON MS	LF	WF	DMIN	KAPR	Insert	Shim Seat	Clamp	Clamp Screw	Lock Pin
920-000-302	920-000-303	E12Q MCLNR/L3	0.750	7.000	0.500	0.920	95.0	CNMG 322	N/A	CL-7	XNS-36	NL-33
920-000-326	920-000-327	E12S MCLNR/L3	0.750	10.000	0.500	0.920	95.0	CNMG 322	N/A	CL-7	XNS-36	NL-33
920-000-354	920-000-355	E16R MCLNR/L3	1.000	8.000	0.640	1.200	95.0	CNMG 322	N/A	CL-7	XNS-36	NL-33
920-000-383	920-000-384	E16T MCLNR/L3	1.000	12.000	0.640	1.200	95.0	CNMG 322	N/A	CL-7	XNS-36	NL-33
920-000-355	920-000-356	E16R MCLNR/L4	1.000	8.000	0.640	1.200	95.0	CNMG 432	N/A	CL-20	XNS-47	NL-44
920-000-384	920-000-385	E16T MCLNR/L4	1.000	12.000	0.640	1.200	95.0	CNMG 432	N/A	CL-20	XNS-47	NL-44
920-000-412	920-000-413	E20U MCLNR/L4	1.250	14.000	0.765	1.470	95.0	CNMG 432	ICSN-433	CL-20	XNS-47	NL-46
920-000-421	920-000-422	E24U MCLNR/L4	1.500	14.000	0.890	1.730	95.0	CNMG 432	ICSN-433	CL-20	XNS-47	NL-46

USE THE RIGHT SET SCREW FLAT POINT, NOT CUP POINT

PRODUCT #	Clamp
968-000-016	CL-6
968-000-017	CL-7
968-000-020	CL-9
968-000-010	CL-12
968-000-011	CL-19
968-000-012	CL-20

PRODUCT #	Clamp
968-000-013	CL-21
968-000-014	CL-22
968-000-015	CL-30
968-000-018	CL-84
968-000-019	CL-85

PACKAGE SIZE OF 1

PRODUCT #	Clamp Screw
968-000-176	XNS-36
968-000-177	XNS-47
968-000-178	XNS-48
968-000-179	XNS-510
968-000-180	XNS-58
968-000-181	XNS-59

PACKAGE SIZE OF 5

PRODUCT #	Shim Screw
968-000-109	PB3-SS
968-000-111	PB4-SS

PACKAGE SIZE OF 5

PRODUCT #	Clamp Assy.
968-000-107	PB3-CA
968-000-110	PB4-CA

PACKAGE SIZE OF 1



CARBIDE

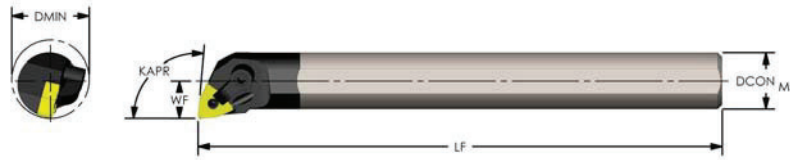

Negative Trigon (KAPR: 95°)

8:1 Ratio
Coolant Thru

PRODUCT # Left hand	PRODUCT # Right hand	Designation	DCON MS	LF	WF	DMIN	KAPR	Insert	Shim Seat	Clamp	Clamp Screw	Lock Pin
920-000-304	920-000-305	E12Q MWLNR/L3	0.750	7.000	0.500	0.920	95.0	WNMG 332	N/A	CL-7	XNS-36	NL-33L
920-000-328	920-000-329	E12S MWLNR/L3	0.750	10.000	0.500	0.920	95.0	WNMG 332	N/A	CL-7	XNS-36	NL-33L
920-000-358	920-000-360	E16R MWLNR/L3	1.000	8.000	0.640	1.200	95.0	WNMG 332	N/A	CL-7	XNS-36	NL-33L
920-000-388	920-000-390	E16T MWLNR/L3	1.000	12.000	0.640	1.200	95.0	WNMG 332	N/A	CL-7	XNS-36	NL-33L
920-000-359	920-000-361	E16R MWLNR/L4	1.000	8.000	0.640	1.200	95.0	WNMG 432	N/A	CL-20	XNS-47	NL-44
920-000-389	920-000-391	E16T MWLNR/L4	1.000	12.000	0.640	1.200	95.0	WNMG 432	N/A	CL-20	XNS-47	NL-44
920-000-415	920-000-416	E20U MWLNR/L4	1.250	14.000	0.765	1.470	95.0	WNMG 432	IWSN-433	CL-20	XNS-47	NL-46
920-000-424	920-000-425	E24U MWLNR/L4	1.500	14.000	0.890	1.730	95.0	WNMG 432	IWSN-433	CL-20	XNS-47	NL-46

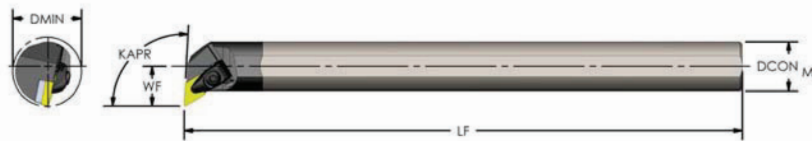

Negative 55° Diamond (KAPR: 93°) Shank

8:1 Ratio
Coolant Thru

PRODUCT #	Designation	DCON MS	LF	WF	DMIN	KAPR	Insert	Shim	Shim Screw	Clamp Assy.
920-000-411	E20U DDUNR4	1.250	14.000	1.000	1.700	93.0	DNMG 432	IDSN 433	PB4-SS	PB4-CA

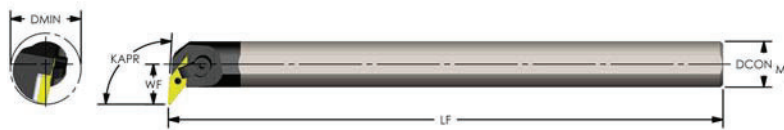

Negative 35° Diamond (KAPR: 93°) Profiling

8:1 Ratio
No Coolant

PRODUCT #	Designation	DCON MS	LF	WF	DMIN	KAPR	Insert	Shim Seat	Clamp	Clamp Screw	Lock Pin
920-000-387	E16T MVUNR3	1.000	12.000	0.875	1.435	93.0	VNMG 332	IVSN-322	CL-20	XNS-47	NL-34L
920-000-414	E20U MVUNR3	1.250	14.000	1.000	1.705	93.0	VNMG 332	IVSN-322	CL-20	XNS-47	NL-34L
920-000-423	E24U MVUNR3	1.500	14.000	1.120	1.960	93.0	VNMG 332	IVSN-322	CL-20	XNS-47	NL-34L

PRODUCT #	Shim Seat
968-000-053	ICSN-433
968-000-054	ICSN-533
968-000-055	ICSN-633
968-000-063	ISSN-432
968-000-064	ISSN-433
968-000-065	ISSN-533
968-000-066	ISSN-633
968-000-056	IDSN-322
968-000-057	IDSN-433
968-000-058	IDSN-533
968-000-067	ITSN-323
968-000-068	ITSN-433

PRODUCT #	Shim Seat
968-000-069	ITSN-533
968-000-070	ITSN-636
968-000-071	IVSN-322
968-000-072	IVSN-432
968-000-073	IVSN-433
968-000-074	IWSN-322
968-000-075	IWSN-433
968-000-059	IRSN-32
968-000-060	IRSN-43
968-000-061	IRSN-53
968-000-062	IRSN-63

PACKAGE SIZE OF 10

PRODUCT #	Lock Pin
968-000-097	NL-33
968-000-098	NL-33L
968-000-099	NL-34
968-000-100	NL-34L
968-000-101	NL-44
968-000-102	NL-46
968-000-103	NL-56
968-000-104	NL-58
968-000-105	NL-68
968-000-106	NL-68L

PACKAGE SIZE OF 5

PRODUCT #	Shim Screw
968-000-109	PB3-SS
968-000-111	PB4-SS

PACKAGE SIZE OF 5

PRODUCT #	Clamp Assy.
968-000-107	PB3-CA
968-000-110	PB4-CA

PACKAGE SIZE OF 1

CARBIDE

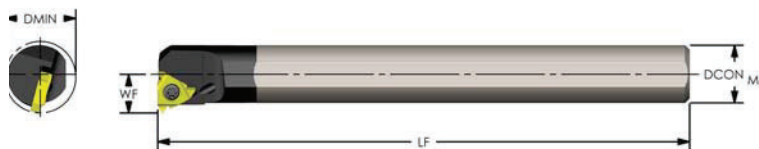

Threading/Grooving Laydown

8:1 Ratio
Coolant Thru

PRODUCT #	Designation Right Hand	DCON MS	LF	WF	DMIN	Insert	Insert Screw	Anvil Screw	Anvil
920-000-210	E08R LSER2	0.500	8.000	0.308	0.588	2IR	SR34505L	N/A	N/A
920-000-249	E10Q LSER2	0.625	7.000	0.371	0.721	2IR	SR34505L	N/A	N/A
920-000-301	E12Q LSER3	0.750	7.000	0.510	0.935	3IR	MTS-35	N/A	N/A
920-000-325	E12S LSER3	0.750	10.000	0.510	0.935	3IR	MTS-35	N/A	N/A
920-000-353	E16R LSER3	1.000	8.000	0.650	1.210	3IR	SA3T	SY3T	YI3
920-000-381	E16T LSER3	1.000	12.000	0.650	1.210	3IR	SA3T	SY3T	YI3

PRODUCT #	Designation Left Hand	DCON MS	LF	WF	DMIN	Insert	Insert Screw	Anvil Screw	Anvil
920-000-209	E08R LSEL2	0.500	8.000	0.308	0.588	2IL	SR34505L	N/A	N/A
920-000-248	E10Q LSEL2	0.625	7.000	0.371	0.721	2IL	SR34505L	N/A	N/A
920-000-300	E12Q LSEL3	0.750	7.000	0.510	0.935	3IL	MTS-35	N/A	N/A
920-000-324	E12S LSEL3	0.750	10.000	0.510	0.935	3IL	MTS-35	N/A	N/A
920-000-352	E16R LSEL3	1.000	8.000	0.650	1.210	3IL	SA3T	SY3T	YE3
920-000-382	E16T LSEL3	1.000	12.000	0.650	1.210	3IL	SA3T	SY3T	YE3

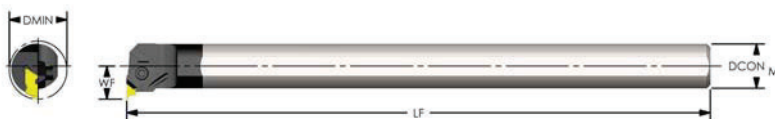

Threading/Grooving Top Notch

8:1 Ratio
Coolant Thru

PRODUCT #	Designation Right Hand	DCON MS	LF	WF	DMIN	Insert	Clamp	Clamp Screw
920-000-212	E08R NER2	0.500	8.000	0.437	0.730	NG 2L	CM-147	6-32
920-000-274	E10S NER2	0.625	10.000	0.500	1.000	NG 2L	CM-75	6-32
920-000-331	E12S NER2	0.750	10.000	0.562	1.120	NG 2L	CM-75	6-32

PRODUCT #	Designation Left Hand	DCON MS	LF	WF	DMIN	Insert	Clamp	Clamp Screw
920-000-211	E08R NEL2	0.500	8.000	0.437	0.730	NG 2R	CM-146	6-32
920-000-273	E10S NEL2	0.625	10.000	0.500	1.000	NG 2R	CM-74	6-32
920-000-330	E12S NEL2	0.750	10.000	0.562	1.120	NG 2R	CM-74	6-32

PRODUCT #	Clamp
968-000-016	CL-6
968-000-017	CL-7
968-000-020	CL-9
968-000-010	CL-12
968-000-011	CL-19
968-000-012	CL-20

PRODUCT #	Clamp
968-000-013	CL-21
968-000-014	CL-22
968-000-015	CL-30
968-000-018	CL-84
968-000-019	CL-85

PACKAGE SIZE OF 1

PRODUCT #	Anvil
968-000-185	YI3
968-000-182	YE3
968-000-187	YI4
968-000-186	YI3M-1.5N
968-000-183	YE4
968-000-188	YI5
968-000-184	YE5

PACKAGE SIZE OF 1

PRODUCT #	Anvil Screw
968-000-146	SY3T
968-000-147	SY4T
968-000-148	SY5T

PACKAGE SIZE OF 5

PRODUCT #	Insert Screw
968-000-124	SA3T
968-000-125	SA4T
968-000-126	SA5T

PACKAGE SIZE OF 5



CARBIDE

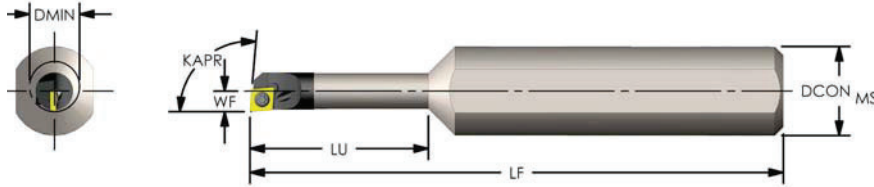

Positive 80° Diamond (KAPR: 95°) Reduced Neck SERIES "C"

Coolant Thru

PRODUCT #	Designation	DCON MS	KAPR	LF	LU	WF	DMIN	KAPR	Insert	Insert Screw	Key	Price
915-000-004	CCUD-180/500-7/8-5R	0.500	0.189	2.380	0.875	0.104	0.208	95.0	CDHB 1.20.60.5	MTS-183	T-6	\$299.10
915-000-008	CCUD-203/500-1-5R	0.500	0.210	2.500	1.000	0.119	0.230	95.0	CDHB 1.20.60.5	MTS-183	T-6	\$299.10
915-000-005	CCUD-180/625-7/8-5R	0.625	0.189	3.000	0.875	0.104	0.208	95.0	CDHB 1.20.60.5	MTS-183	T-6	\$331.60
915-000-009	CCUD-203/625-1-5R	0.625	0.210	3.500	1.000	0.119	0.230	95.0	CDHB 1.20.60.5	MTS-183	T-6	\$299.10
915-000-010	CCUD-250/625-1 1/4-5R	0.625	0.260	3.000	1.250	0.145	0.285	95.0	CDHB 1.20.60.5	MTS-184	T-6	\$320.40

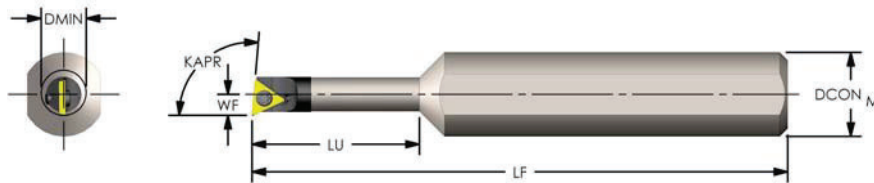

Positive Triangle (KAPR: 95°) Reduced Neck SERIES "F"

Coolant Thru

PRODUCT #	Designation	DCON MS	KAPR	LF	LU	WF	DMIN	KAPR	Insert	Insert Screw	Key	Price
915-000-032	FCUD-250/500-1 1/4-5R	0.500	0.260	2.750	1.250	0.156	0.300	95.0	TDHB 1.280.750.5	MTS-224	T-7	\$284.50
915-000-036	FCUD-312/500-3 1/8-5R	0.500	0.322	4.630	3.125	0.187	0.360	95.0	TDHB 1.280.750.5	MTS-224	T-7	\$290.10
915-000-033	FCUD-250/625-1 1/4-5R	0.625	0.260	4.000	1.250	0.156	0.300	95.0	TDHB 1.280.750.5	MTS-224	T-7	\$299.10
915-000-037	FCUD-312/625-1 1/2-5R	0.625	0.322	4.000	1.500	0.187	0.360	95.0	TDHB 1.280.750.5	MTS-224	T-7	\$299.10

PRODUCT #	Insert Screws	Price Each
968-000-086	MTS-183	\$3.20
968-000-087	MTS-184	\$3.20
968-000-088	MTS-2	\$2.90
968-000-091	MTS-224	\$3.20
968-000-092	MTS-255	\$3.20
968-000-094	MTS-35	\$3.20
968-000-090	MTS-2.5L	\$2.90
968-000-052	ETS 4-40	\$3.20

PACKAGE SIZE OF 5

PRODUCT #	Key	Price Each
968-000-156	T-6	\$4.20
968-000-158	T-7	\$3.80
968-000-149	T-10	\$6.50
968-000-151	T-15	\$3.80
968-000-153	T-20	\$4.00

PACKAGE SIZE OF 5

USE THE RIGHT SET SCREW FLAT POINT, NOT CUP POINT



Coated &
Uncoated

Positive 80° Diamond

8:1 Ratio
No Coolant

PRODUCT #	Designation	DMIN	LU	DCON MS	LF	GRADE
951-000-037	UD125-020-75R	0.020	0.075	0.125	1.500	UD5
951-000-038		0.020	0.075	0.125	1.500	UD51
951-000-039		0.020	0.075	0.125	1.500	UD52
951-000-040	UD125-030-100R	0.030	0.100	0.125	1.500	UD5
951-000-041		0.030	0.100	0.125	1.500	UD51
951-000-042		0.030	0.100	0.125	1.500	UD52
951-000-043	UD125-040-150R	0.040	0.150	0.125	1.500	UD5
951-000-044		0.040	0.150	0.125	1.500	UD51
951-000-045		0.040	0.150	0.125	1.500	UD52
951-000-046	UD125-050-150R	0.050	0.150	0.125	1.500	UD5
951-000-047		0.050	0.150	0.125	1.500	UD51
951-000-048		0.050	0.150	0.125	1.500	UD52
951-000-001	UD125-060-188R	0.060	0.188	0.125	1.500	UD5
951-000-002		0.060	0.188	0.125	1.500	UD51
951-000-003		0.060	0.188	0.125	1.500	UD52
951-000-004	UD125-080-375R	0.080	0.375	0.125	1.500	UD5
951-000-005		0.080	0.375	0.125	1.500	UD51
951-000-006		0.080	0.375	0.125	1.500	UD52
951-000-007	UD125-090-500R	0.090	0.500	0.125	1.500	UD5
951-000-008		0.090	0.500	0.125	1.500	UD51
951-000-009		0.090	0.500	0.125	1.500	UD52
951-000-010	UD125-120-625R	0.120	0.625	0.125	1.500	UD5
951-000-011		0.120	0.625	0.125	1.500	UD51
951-000-012		0.120	0.625	0.125	1.500	UD52
951-000-013	UD188-150-750R	0.150	0.750	0.188	2.000	UD5
951-000-014		0.150	0.750	0.188	2.000	UD51
951-000-015		0.150	0.750	0.188	2.000	UD52
951-000-016	UD188-180-1.00R	0.180	1.000	0.188	2.000	UD5
951-000-017		0.180	1.000	0.188	2.000	UD51
951-000-018		0.180	1.000	0.188	2.000	UD52
951-000-019	UD250-210-1.25R	0.210	1.250	0.250	2.500	UD5
951-000-020		0.210	1.250	0.250	2.500	UD51
951-000-021		0.210	1.250	0.250	2.500	UD52
951-000-022	UD250-240-1.25R	0.240	1.250	0.250	2.500	UD5
951-000-023		0.240	1.250	0.250	2.500	UD51
951-000-024		0.240	1.250	0.250	2.500	UD52
951-000-025	UD312-270-1.25R	0.270	1.250	0.312	2.500	UD5
951-000-026		0.270	1.250	0.312	2.500	UD51
951-000-027		0.270	1.250	0.312	2.500	UD52
951-000-028	UD312-300-1.25R	0.300	1.250	0.312	2.500	UD5
951-000-029		0.300	1.250	0.312	2.500	UD51
951-000-030		0.300	1.250	0.312	2.500	UD52
951-000-031	UD375-330-1.50R	0.330	1.500	0.375	2.500	UD5
951-000-032		0.330	1.500	0.375	2.500	UD51
951-000-033		0.330	1.500	0.375	2.500	UD52
951-000-034	UD375-360-1.50R	0.360	1.500	0.375	2.500	UD5
951-000-035		0.360	1.500	0.375	2.500	UD51
951-000-036		0.360	1.500	0.375	2.500	UD52

The following services are for **Carbide** bars only:

Cut-Off Service	Extra-Flat Service
up to 3/8" diameter	up to 5/16" diameter
1/2" diameter	3/8" - 1/2" diameter
5/8" diameter	5/8" - 3/4" diameter
3/4" diameter	1" - 2" diameter
1" diameter	
1 1/4" diameter	
1 1/2" diameter	
1 3/4" diameter	
2" diameter	

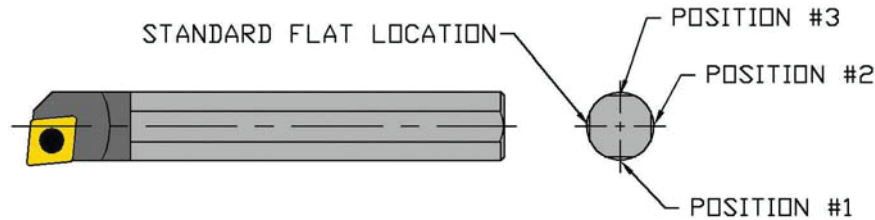

Ordering is easy, Use part # "Cut-Off" and specify the length in the item description
Use part # "Extra-Flat" and specify the location in the item description

Have us braze on a steel coolant adapter to any **Carbide** Boring Bar 1/2" or larger!



Comes with 1/16-27 NPT (or) 1/8-27 NPT
Plastic loc-line NOT included

Item Designations:
Coolant Adapter - 1/16
Coolant Adapter - 1/8

Designation Depends on the Diameter of the Bar:
Coolant Adapter-1/16 for 1/2" Diameter Bars
Coolant Adapter-1/8 for 5/8" Diameter Bars and Larger

HEAVY METAL BORING BARS

Vibration dampening
to help reduce chatter
in your application

- Machine deeper bores
- Achieve better precision and finish

Up to 6:1 Ratio

.187”-.750” Diameters



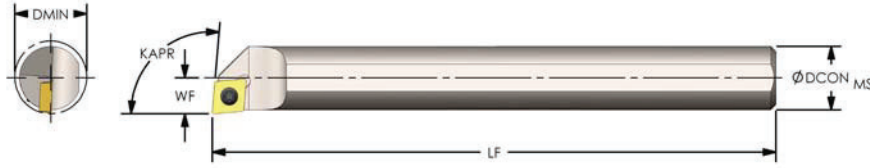

Positive 80° Diamond (KAPR: 95°)

6:1 Ratio
No Coolant

PRODUCT # Left hand	PRODUCT # Right hand	Designation	DCON MS	LF	WF	DMIN	KAPR	Insert	Insert Screw	Key
940-000-097	940-000-098	J03F SCLDR/L1.2 *	0.187	3.000	0.102	0.205	95.0	CDHB 1.20.60	MTS-183	T-6
940-000-100	940-000-101	J04F SCLDR/L1.5-138 * ■	0.250	3.000	0.138	0.275	95.0	CDGW 1.510	MTS-184	T-6
940-000-105	940-000-106	J05H SCLPR/L1.8-167 * ■	0.312	4.000	0.167	0.340	95.0	CPMT 1.81.20.5	MTS-224	T-7

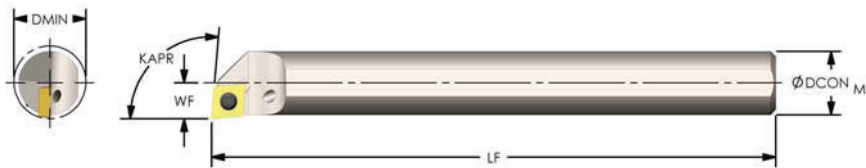

Positive 80° Diamond (KAPR: 95°)

Coolant Thru

PRODUCT # Left hand	PRODUCT # Right hand	Designation	DCON MS	LF	WF	DMIN	KAPR	Insert	Insert Screw	Key
940-000-003	940-000-004	HM06J SCLPR/L2-203 ■	0.375	4.500	0.203	0.410	95.0	CPMT 21.51	MTS-255	T-7
940-000-015	940-000-016	HM06Q SCLPR/L2-203 ■	0.375	7.000	0.203	0.410	95.0	CPMT 21.51	MTS-255	T-7
940-000-027	940-000-028	HM08J SCLPR/L2-281 ■	0.500	4.500	0.281	0.560	95.0	CPMT 21.51	MTS-255	T-7
940-000-037	940-000-038	HM08Q SCLPR/L2-281 ■	0.500	7.000	0.281	0.560	95.0	CPMT 21.51	MTS-255	T-7
940-000-049	940-000-051	HM10J SCLPR/L2	0.625	4.500	0.406	0.760	95.0	CPMT 21.51	MTS-255	T-7
940-000-065	940-000-067	HM10Q SCLPR/L2	0.625	7.000	0.406	0.760	95.0	CPMT 21.51	MTS-255	T-7
940-000-050	940-000-052	HM10J SCLPR/L3	0.625	4.500	0.406	0.760	95.0	CPMT 32.51	MTS-35	T-15
940-000-066	940-000-067	HM10Q SCLPR/L3	0.625	7.000	0.406	0.760	95.0	CPMT 32.51	MTS-35	T-15
940-000-079	940-000-080	HM12J SCLPR/L3	0.750	4.500	0.500	0.920	95.0	CPMT 32.51	MTS-35	T-15
940-000-089	940-000-090	HM12Q SCLPR/L3	0.750	7.000	0.500	0.920	95.0	CPMT 32.51	MTS-35	T-15
940-000-001	940-000-002	HM06J SCLCR/L2-203 ■	0.375	4.500	0.203	0.410	95.0	CCMT 21.51	MTS-255	T-7
940-000-013	940-000-014	HM06Q SCLCR/L2-203 ■	0.375	7.000	0.203	0.410	95.0	CCMT 21.51	MTS-255	T-7
940-000-025	940-000-026	HM08J SCLCR/L2-281 ■	0.500	4.500	0.281	0.560	95.0	CCMT 21.51	MTS-255	T-7
940-000-035	940-000-036	HM08Q SCLCR/L2-281 ■	0.500	7.000	0.281	0.560	95.0	CCMT 21.51	MTS-255	T-7
940-000-045	940-000-047	HM10J SCLCR/L2	0.625	4.500	0.406	0.760	95.0	CCMT 21.51	MTS-255	T-7
940-000-061	940-000-063	HM10Q SCLCR/L2	0.625	7.000	0.406	0.760	95.0	CCMT 21.51	MTS-255	T-7
940-000-046	940-000-048	HM10J SCLCR/L3	0.625	4.500	0.406	0.760	95.0	CCMT 32.51	MTS-35	T-15
940-000-062	940-000-064	HM10Q SCLCR/L3	0.625	7.000	0.406	0.760	95.0	CCMT 32.51	MTS-35	T-15
940-000-077	940-000-078	HM12J SCLCR/L3	0.750	4.500	0.500	0.920	95.0	CCMT 32.51	MTS-35	T-15
940-000-087	940-000-088	HM12Q SCLCR/L3	0.750	7.000	0.500	0.920	95.0	CCMT 32.51	MTS-35	T-15

■ Minimum Clearance Bars are intended for light machining with minimum bore clearance. Max depth of cut .015" - .020"
*bars .312 and smaller do not have flats

HEAVY METAL

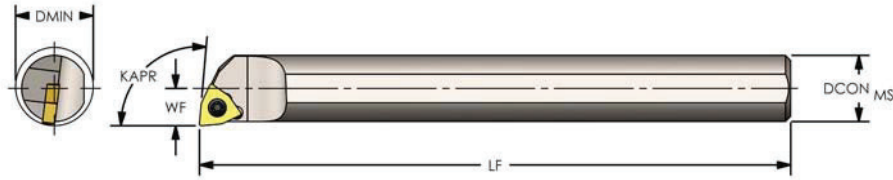

Positive Trigon (KAPR: 95°)

6:1 Ratio
No Coolant

PRODUCT # Right hand	Designation	DCON MS	LF	WF	DMIN	KAPR	Insert	Insert Screw	Key
940-000-099	J03F SWLCR1.2 *	0.187	3.000	0.102	0.205	95.0	WCMT 1.210.5	MTS-183	T-6
940-000-104	J04F SWLCR1.2-138 * ■	0.250	3.000	0.138	0.275	95.0	WCMT 1.210.5	MTS-184	T-6
940-000-109	J05H SWLCR1.5-167 * ■	0.312	4.000	0.167	0.342	95.0	WCMT 1.51.50.5	MTS-2	T-6

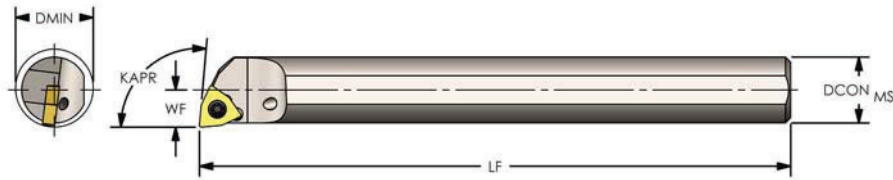

Positive Trigon (KAPR: 95°)

Coolant Thru

PRODUCT # Left hand	PRODUCT # Right hand	Designation	DCON MS	LF	WF	DMIN	KAPR	Insert	Insert Screw	Key
940-000-011	940-000-012	HM06J SWLCR/L2-203 ■	0.375	4.500	0.203	0.410	95.0	WCMT 21.51	MTS-255	T-7
940-000-023	940-000-024	HM06Q SWLCR/L2-203 ■	0.375	7.000	0.203	0.410	95.0	WCMT 21.51	MTS-255	T-7
940-000-033	940-000-034	HM08J SWLCR/L2-281 ■	0.500	4.500	0.281	0.560	95.0	WCMT 21.51	MTS-255	T-7
940-000-043	940-000-044	HM08Q SWLCR/L2-281 ■	0.500	7.000	0.281	0.560	95.0	WCMT 21.51	MTS-255	T-7
940-000-057	940-000-059	HM10J SWLCR/L2	0.625	4.500	0.406	0.760	95.0	WCMT 21.51	MTS-255	T-7
940-000-073	940-000-075	HM10Q SWLCR/L2	0.625	7.000	0.406	0.760	95.0	WCMT 21.51	MTS-255	T-7
940-000-058	940-000-060	HM10J SWLCR/L3	0.625	4.500	0.406	0.760	95.0	WCMT 32.51	MTS-35	T-15
940-000-074	940-000-076	HM10Q SWLCR/L3	0.625	7.000	0.406	0.760	95.0	WCMT 32.51	MTS-35	T-15
940-000-085	940-000-086	HM12J SWLCR/L3	0.750	4.500	0.500	0.920	95.0	WCMT 32.51	MTS-35	T-15
940-000-095	940-000-096	HM12Q SWLCR/L3	0.750	7.000	0.500	0.920	95.0	WCMT 32.51	MTS-35	T-15

■ Minimum Clearance Bars are intended for light machining with minimum bore clearance. Max depth of cut .015" - .020"
*bars .312 and smaller do not have flats

PRODUCT #	Insert Screws
968-000-086	MTS-183
968-000-087	MTS-184
968-000-088	MTS-2
968-000-091	MTS-224
968-000-092	MTS-255
968-000-094	MTS-35
968-000-090	MTS-2.5L
968-000-052	ETS 4-40

PACKAGE SIZE OF 5

PRODUCT #	Key
968-000-156	T-6
968-000-158	T-7
968-000-149	T-10
968-000-151	T-15
968-000-153	T-20

PACKAGE SIZE OF 5

HEAVY METAL

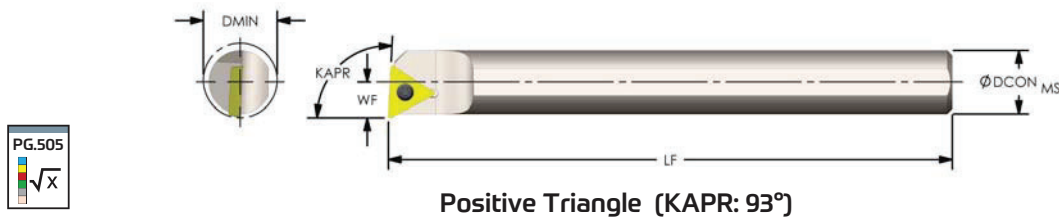

Positive Triangle (KAPR: 93°)

6:1 Ratio
No Coolant

PRODUCT # Left hand	PRODUCT # Right hand	Designation	DCON MS	LF	WF	DMIN	KAPR	Insert	Insert Screw	Key
940-000-102	940-000-103	J04F STUCR/L1.2-138 * ■	0.250	3.000	0.138	0.275	93.0	TCMT 1.21.20.5	MTS-184	T-6
940-000-107	940-000-108	J05H STUCR/L1.2-167 * ■	0.312	4.000	0.167	0.340	93.0	TCMT 1.21.20.5	MTS-184	T-6

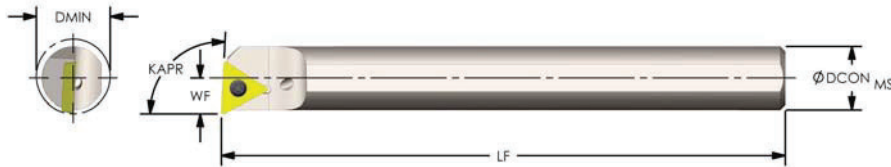

Positive Triangle (KAPR: 93°)

Coolant Thru

PRODUCT # Left hand	PRODUCT # Right hand	Designation	DCON MS	LF	WF	DMIN	KAPR	Insert	Insert Screw	Key
940-000-005	940-000-007	HM06J STUCR/L1.2-203 ■	0.375	4.500	0.203	0.410	93.0	TCMT 1.21.20.5	MTS-184	T-6
940-000-017	940-000-019	HM06Q STUCR/L1.2-203 ■	0.375	7.000	0.203	0.410	93.0	TCMT 1.21.20.5	MTS-184	T-6
940-000-009	940-000-010	HM06J STUPR/L2-203 ■	0.375	4.500	0.203	0.410	93.0	TPMT 21.51	MTS-255	T-7
940-000-021	940-000-022	HM06Q STUPR/L2-203 ■	0.375	7.000	0.203	0.410	93.0	TPMT 21.51	MTS-255	T-7
940-000-031	940-000-032	HM08J STUPR/L2-281 ■	0.500	4.500	0.281	0.560	93.0	TPMT 21.51	MTS-255	T-7
940-000-041	940-000-042	HM08Q STUPR/L2-281 ■	0.500	7.000	0.281	0.560	93.0	TPMT 21.51	MTS-255	T-7
940-000-055	940-000-056	HM10J STUPR/L2	0.625	4.500	0.406	0.760	93.0	TPMT 21.51	MTS-255	T-7
940-000-071	940-000-072	HM10Q STUPR/L2	0.625	7.000	0.406	0.760	93.0	TPMT 21.51	MTS-255	T-7
940-000-083	940-000-084	HM12J STUPR/L3	0.750	4.500	0.500	0.920	93.0	TPMT 32.51	MTS-35	T-15
940-000-093	940-000-094	HM12Q STUPR/L3	0.750	7.000	0.500	0.920	93.0	TPMT 32.51	MTS-35	T-15
940-000-006	940-000-008	HM06J STUCR/L2-203 ■	0.375	4.500	0.203	0.410	93.0	TCMT 21.51	MTS-255	T-7
940-000-018	940-000-020	HM06Q STUCR/L2-203 ■	0.375	7.000	0.203	0.410	93.0	TCMT 21.51	MTS-255	T-7
940-000-029	940-000-030	HM08J STUCR/L2-281 ■	0.500	4.500	0.281	0.560	93.0	TCMT 21.51	MTS-255	T-7
940-000-039	940-000-040	HM08Q STUCR/L2-281 ■	0.500	7.000	0.281	0.560	93.0	TCMT 21.51	MTS-255	T-7
940-000-053	940-000-054	HM10J STUCR/L2	0.625	4.500	0.406	0.760	93.0	TCMT 21.51	MTS-255	T-7
940-000-069	940-000-070	HM10Q STUCR/L2	0.625	7.000	0.406	0.760	93.0	TCMT 21.51	MTS-255	T-7
940-000-081	940-000-082	HM12J STUCR/L3	0.750	4.500	0.500	0.920	93.0	TCMT 32.51	MTS-35	T-15
940-000-091	940-000-092	HM12Q STUCR/L3	0.750	7.000	0.500	0.920	93.0	TCMT 32.51	MTS-35	T-15

■ Minimum Clearance Bars are intended for light machining with minimum bore clearance. Max depth of cut .015" - .020"
*bars .312 and smaller do not have flats

PRODUCT #	Insert Screws
968-000-086	MTS-183
968-000-087	MTS-184
968-000-088	MTS-2
968-000-091	MTS-224
968-000-092	MTS-255
968-000-094	MTS-35
968-000-090	MTS-2.5L
968-000-052	ETS 4-40

PRODUCT #	Key
968-000-156	T-6
968-000-158	T-7
968-000-149	T-10
968-000-151	T-15
968-000-153	T-20

PACKAGE SIZE OF 5

PACKAGE SIZE OF 5

MODULAR BORING BARS

Endless possibilities and the convenience of one bar with 28 different insert style configurations

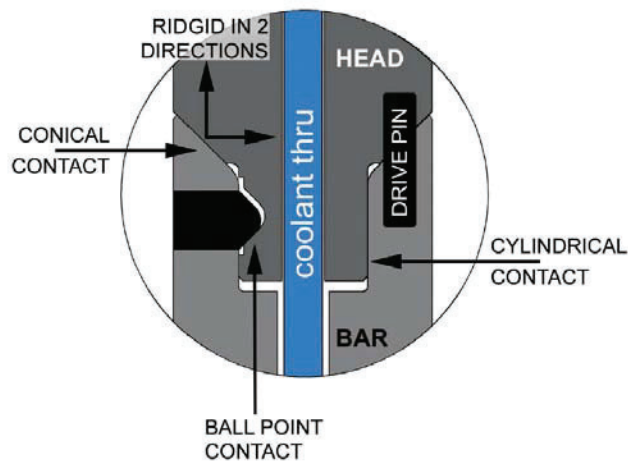

ULTRA-DEX[®]



4:1 Ratio

STEEL SHANK

Coolant Thru

PRODUCT #	Designation	DCONMS	LF	DCONWS	Insert
944-000-019	MBS 1295	0.750	9.500	0.750	MH12S
944-000-020	MBS 1612	1.000	11.500	1.000	MH16S
944-000-021	MBS 2014	1.250	14.000	1.250	MH20S
944-000-022	MBS 2414	1.500	14.000	1.500	MH24S
944-000-023	MBS 2816	1.750	16.000	1.750	MH28S
944-000-024	MBS 3210	2.000	10.000	2.000	MH32S
944-000-025	MBS 3220	2.000	20.000	2.000	MH32S
944-000-026	MBS 4012*	2.500	12.000	2.000	MH32S
944-000-027	MBS 4024*	2.500	24.000	2.000	MH32S
944-000-028	MBS 4828*	3.000	28.000	2.000	MH32S

*2.5" and 3" bars take 2" heads

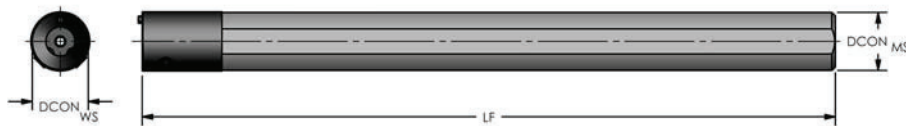

8:1 Ratio

CARBIDE SHANK

Coolant Thru

PRODUCT #	Designation	DCONMS	LF	DCONWS	Insert
944-000-002	MB 1295	0.750	9.500	0.750	MH12S
944-000-001	MB 1220M	20mm	241mm	0.750	MH12S
944-000-003	MB 1612	1.000	11.500	1.000	MH16S
944-000-004	MB 2014	1.250	14.000	1.250	MH20S
944-000-005	MB 2414	1.500	14.000	1.500	MH24S
944-000-006	MB 2816	1.750	16.000	1.750	MH28S
944-000-007	MB 3220	2.000	20.000	2.000	MH32S
944-000-026	MBS 4012*	2.500	12.000	2.000	MH32S
944-000-027	MBS 4024*	2.500	24.000	2.000	MH32S
944-000-028	MBS 4828*	3.000	28.000	2.000	MH32S

PRODUCT #	Set Screws	Price Each
968-000-076	MH12S	\$1.80
968-000-077	MH16S	\$2.10
968-000-078	MH20S	\$2.50
968-000-079	MH24S	\$2.50
968-000-080	MH28S	\$3.20
968-000-081	MH32S	\$3.60

PACKAGE SIZE OF 2

MODULAR

ULTRA-DEX[®]

MODULAR

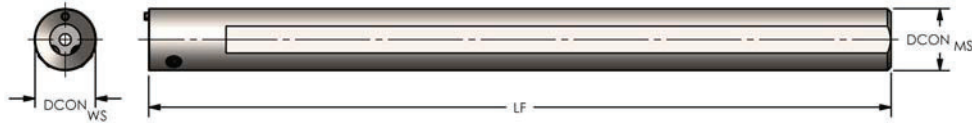

HEAVY METAL SHANK

6:1 Ratio
Coolant Thru

PRODUCT #	Designation	DCONMS	LF	DCONWS	Insert
944-000-008	MBH 1212	0.750	12.000	0.750	MH12S
944-000-009	MBH 1612	1.000	12.000	1.000	MH16S
944-000-010	MBH 2012	1.250	12.000	1.250	MH20S
944-000-011	MBH 2412	1.500	12.000	1.500	MH24S
944-000-012	MBH 2414	1.500	14.000	1.500	MH24S
944-000-013	MBH 2812	1.750	12.000	1.750	MH28S
944-000-014	MBH 2816 *	1.750	16.000	1.750	MH28S
944-000-015	MBH 3212	2.000	12.000	2.000	MH32S
944-000-016	MBH 3218 *	2.000	18.000	2.000	MH32S
944-000-017	MBH 4024 **	2.500	24.000	2.000	MH32S
944-000-018	MBH 4828 **	3.000	28.000	2.000	MH32S

*non-stock item; call for delivery

**2.5" and 3" bars take 2" heads

PRODUCT #	Set Screws
968-000-076	MH12S
968-000-077	MH16S
968-000-078	MH20S
968-000-079	MH24S
968-000-080	MH28S
968-000-081	MH32S

PACKAGE SIZE OF 2

ULTRA-DEX[®]

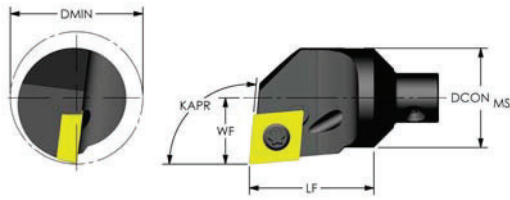

Positive 80° Diamond (KAPR: 95°)



Coolant Thru

PRODUCT # Left hand	PRODUCT # Right hand	Designation	DCON MS	LF	WF	DMIN	KAPR	Insert	Insert Screw	Key
945-000-017	945-000-018	MH12 SCLCR/L3	0.750	0.940	0.500	0.920	95.0	CCMT 32.51	MTS-35	T-15
945-000-065	945-000-066	MH16 SCLCR/L3	1.000	1.000	0.625	1.185	95.0	CCMT 32.51	MTS-35	T-15
945-000-019	945-000-020	MH12 SCLPR/L3	0.750	0.940	0.500	0.920	95.0	CPMT 32.51	MTS-35	T-15
945-000-067	945-000-068	MH16 SCLPR/L3	1.000	1.000	0.625	1.185	95.0	CPMT 32.51	MTS-35	T-15
N/A	945-000-120	MH20 SCLCR4	1.250	1.300	0.765	1.465	95.0	CCMT 432	MTS-4	T-20
N/A	945-000-156	MH24 SCLCR4	1.500	1.520	0.890	1.730	95.0	CCMT 432	MTS-4	T-20
N/A	945-000-190	MH28 SCLCR4	1.750	1.770	1.015	2.000	95.0	CCMT 432	MTS-4	T-20
N/A	912-000-157	MH32 SCLCR4	2.000	2.030	1.281	2.400	95.0	CCMT 432	MTS-4	T-20

MODULAR

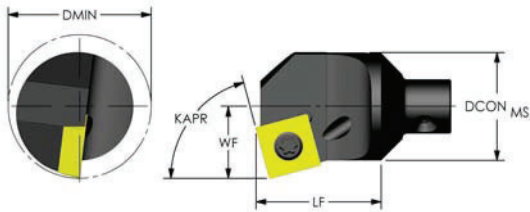

Positive Square (KAPR: 75°)



Coolant Thru

PRODUCT #	Designation	DCON MS	LF	WF	DMIN	KAPR	Insert	Insert Screw	Key
945-000-028	MH12 SSKCR3	0.750	0.875	0.500	0.920	75.0	SCMT 32.51	MTS-35	T-15
945-000-078	MH16 SSKCR4	1.000	0.935	0.625	1.185	75.0	SCMT 432	MTS-4	T-20

PRODUCT #	Insert Screws
968-000-086	MTS-183
968-000-087	MTS-184
968-000-088	MTS-2
968-000-091	MTS-224
968-000-092	MTS-255
968-000-094	MTS-35
968-000-090	MTS-2.5L
968-000-052	ETS 4-40

PACKAGE SIZE OF 5

PRODUCT #	Key
968-000-156	T-6
968-000-158	T-7
968-000-149	T-10
968-000-151	T-15
968-000-153	T-20

PACKAGE SIZE OF 5

ULTRA-DEX[®]

MODULAR

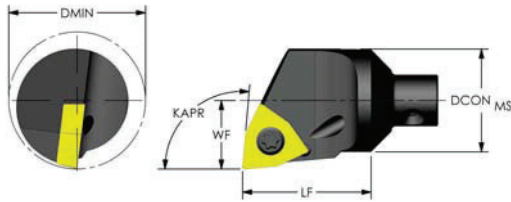

Positive Trigon (KAPR: 95°)



Coolant Thru

PRODUCT # Left hand	PRODUCT # Right hand	Designation	DCON MS	LF	WF	DMIN	KAPR	Insert	Insert Screw	Key
945-000-037	945-000-038	MH12 SWLCR/L3	0.750	0.940	0.500	0.920	95.0	WCMT 32.51	MTS-35	T-15
945-000-087	945-000-088	MH16 SWLCR/L3	1.000	1.000	0.625	1.185	95.0	WCMT 32.51	MTS-35	T-15

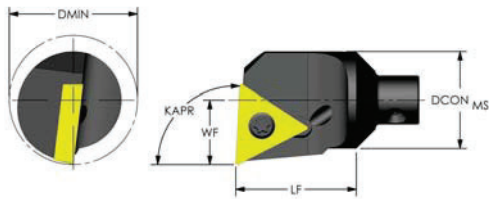

Positive Triangle (KAPR: 93°)



Coolant Thru

PRODUCT # Left hand	PRODUCT # Right hand	Designation	DCON MS	LF	WF	DMIN	KAPR	Insert	Insert Screw	Key
945-000-031	945-000-032	MH12 STUCR/L3	0.750	0.940	0.500	0.920	95.0	TCMT 32.51	MTS-35	T-15
945-000-081	945-000-082	MH16 STUCR/L3	1.000	1.000	0.625	1.185	95.0	TCMT 32.51	MTS-35	T-15

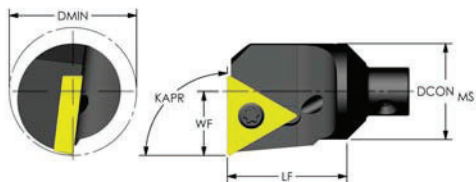

Positive Triangle (KAPR: 90°)



Coolant Thru

PRODUCT # Left hand	PRODUCT # Right hand	Designation	DCON MS	LF	WF	DMIN	KAPR	Insert	Insert Screw	Key
945-000-029	945-000-030	MH12 STFCL/L3	0.750	0.940	0.500	0.920	90.0	TCMT 32.51	MTS-35	T-15
945-000-079	945-000-080	MH16 STFCL/L3	1.000	1.000	.625	1.185	90.0	TCMT 32.51	MTS-35	T-15

PRODUCT #	Insert Screws
968-000-086	MTS-183
968-000-087	MTS-184
968-000-088	MTS-2
968-000-091	MTS-224
968-000-092	MTS-255
968-000-094	MTS-35
968-000-090	MTS-2.5L
968-000-052	ETS 4-40

PACKAGE SIZE OF 5

PRODUCT #	Key
968-000-156	T-6
968-000-158	T-7
968-000-149	T-10
968-000-151	T-15
968-000-153	T-20

PACKAGE SIZE OF 5

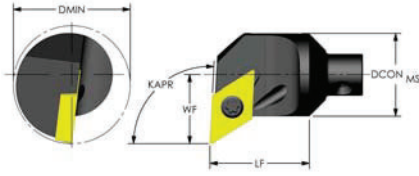

Positive 55° Diamond (KAPR: 95°) Profiling

Coolant Thru

PRODUCT # Left hand	PRODUCT # Right hand	Designation	DCON MS	LF	WF	DMIN	KAPR	Insert	Insert Screw	Key
945-000-024	945-000-025	MH12 SDUCR/L3	0.750	0.940	0.625	1.050	95.0	DCMT 32.51	MTS-35	T-15
945-000-072	945-000-073	MH16 SDUCR/L3	1.000	1.000	0.750	1.310	95.0	DCMT 32.51	MTS-35	T-15
N/A	945-000-123	MH20 SDUCR3-8	1.250	1.300	0.800	1.500	95.0	DCMT 32.51	MTS-35	T-15
945-000-121	945-000-122	MH20 SDUCR/L3	1.250	1.300	1.000	1.700	95.0	DCMT 32.51	MTS-35	T-15
945-000-157	945-000-158	MH24 SDUCR/L3	1.500	1.520	1.120	1.960	95.0	DCMT 32.51	MTS-35	T-15
945-000-191	945-000-192	MH28 SDUCR/L3	1.750	1.770	1.250	2.230	95.0	DCMT 32.51	MTS-35	T-15
945-000-226	945-000-227	MH32 SDUCR/L3	2.000	2.030	1.375	2.500	95.0	DCMT 32.51	MTS-35	T-15

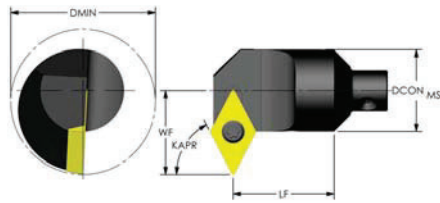

Positive 55° Diamond (KAPR: 62.5°) Profiling

Coolant Thru

PRODUCT #	Designation	DCON MS	LF	WF	DMIN	KAPR	Insert	Insert Screw	Key
945-000-021	MH12 SDNCR3	0.750	0.940	0.765	1.190	62.5	DCMT 32.51	MTS-35	T-15
945-000-069	MH16 SDNCR3	1.000	1.000	0.890	1.450	62.5	DCMT 32.51	MTS-35	T-15

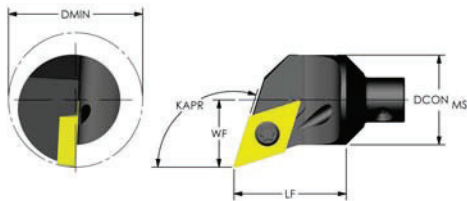

Positive 55° Diamond (KAPR: 107.5°) Profiling

Coolant Thru

PRODUCT # Left hand	PRODUCT # Right hand	Designation	DCON MS	LF	WF	DMIN	KAPR	Insert	Insert Screw	Key
945-000-022	945-000-023	MH12 SDQCR/L3	0.750	0.940	0.562	1.000	107.5	DCMT 32.51	MTS-35	T-15
945-000-070	945-000-071	MH16 SDQCR/L3	1.000	1.000	0.625	1.185	107.5	DCMT 32.51	MTS-35	T-15

PRODUCT #	Insert Screws
968-000-086	MTS-183
968-000-087	MTS-184
968-000-088	MTS-2
968-000-091	MTS-224
968-000-092	MTS-255
968-000-094	MTS-35
968-000-090	MTS-2.5L
968-000-052	ETS 4-40

PACKAGE SIZE OF 5

PRODUCT #	Key
968-000-156	T-6
968-000-158	T-7
968-000-149	T-10
968-000-151	T-15
968-000-153	T-20

PACKAGE SIZE OF 5

ULTRA-DEX[®]

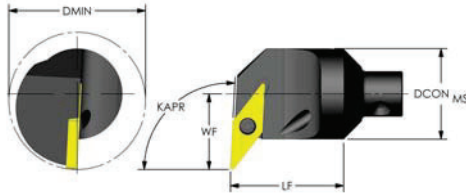

Positive 35° Diamond (KAPR: 93°) Profiling

Coolant Thru

PRODUCT # Left hand	PRODUCT # Right hand	Designation	DCON MS	LF	WF	DMIN	KAPR	Insert	Insert Screw	Key
945-000-035	945-000-036	MH12 SVUBR/L2	0.750	0.940	0.625	1.045	93.0	VBMT 21.51	MTS-2.5L	T-7
945-000-085	945-000-086	MH16 SVUBR/L3	1.000	1.000	0.875	1.435	93.0	VBMT 331	MTS-3.5L	T-15

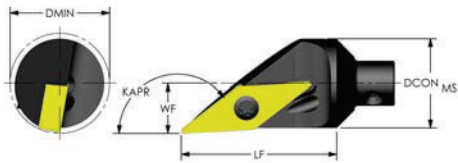

Positive 35° Diamond (KAPR: 142°) Profiling

Coolant Thru

PRODUCT # Left hand	PRODUCT # Right hand	Designation	DCON MS	LF	WF	DMIN	KAPR	Insert	Insert Screw	Key
945-000-033	945-000-034	MH12 SVJBR/L3	0.750	1.315	0.421	0.840	142.0	VBMT 331	MTS-3.5L	T-15
945-000-083	945-000-084	MH16 SVJBR/L3	1.000	1.375	0.546	1.110	142.0	VBMT 331	MTS-3.5L	T-15
945-000-124	945-000-125	MH20 SVJBR/L3	1.250	1.675	0.671	1.700	142.0	VBMT 331	MTS-3.5L	T-15
945-000-161	945-000-162	MH24 SVJBR/L3	1.500	1.895	0.796	1.960	142.0	VBMT 331	MTS-3.5L	T-15
945-000-193	945-000-194	MH28 SVJBR/L3	1.750	2.145	0.921	2.230	142.0	VBMT 331	MTS-3.5L	T-15
945-000-228	945-000-229	MH32 SVJBR/L3	2.000	2.405	1.046	2.500	142.0	VBMT 331	MTS-3.5L	T-15

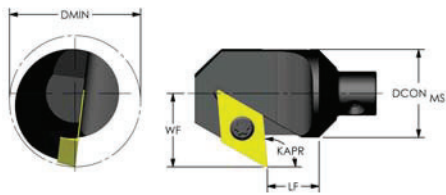

Positive 55° Diamond (KAPR: 95°) Back Facing

Coolant Thru

PRODUCT # Left hand	PRODUCT # Right hand	Designation	DCON MS	LF	WF	DMIN	KAPR	Insert	Insert Screw	Key
945-000-026	945-000-027	MH12 SDXCR/L3	0.750	0.440	0.625	1.050	95.0	DCMT 32.51	MTS-35	T-15
945-000-074	945-000-075	MH16 SDXCR/L3	1.000	0.525	0.750	1.310	95.0	DCMT 32.51	MTS-35	T-15

PRODUCT #	Insert Screws
968-000-086	MTS-183
968-000-087	MTS-184
968-000-088	MTS-2
968-000-091	MTS-224
968-000-092	MTS-255
968-000-094	MTS-35
968-000-090	MTS-2.5L
968-000-052	ETS 4-40

PACKAGE SIZE OF 5

PRODUCT #	Key
968-000-156	T-6
968-000-158	T-7
968-000-149	T-10
968-000-151	T-15
968-000-153	T-20

PACKAGE SIZE OF 5

PRODUCT #	Insert Screws
968-000-093	MTS-3.5L
968-000-095	MTS-4
968-000-096	MTS-526

PACKAGE SIZE OF 1

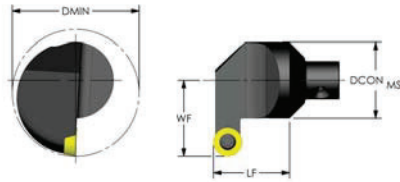

Positive Round

Coolant Thru

PRODUCT # Left hand	PRODUCT # Right hand	Designation	DCON MS	LF	WF	DMIN	Insert	Screw
945-000-076	945-000-077	MH16 SRNCR/L3	1.000	1.000	1.000	1.560	RCMT 32.5	MTS-35
945-000-159	945-000-160	MH24 SRNCR/L4	1.500	1.520	1.250	2.090	RCMT 43	MTS-4

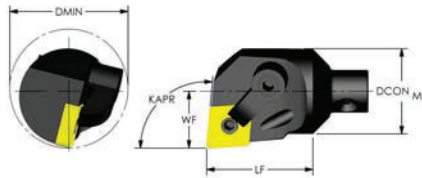

Negative 80° Diamond (KAPR: 95°)

Coolant Thru

PRODUCT # Left hand	PRODUCT # Right hand	Designation	DCON MS	LF	WF	DMIN	KAPR	Insert	Shim	Clamp	Clamp Screw	Lock Pin
945-000-005	945-000-006	MH12 MCLNR/L3	0.750	0.940	0.500	0.920	95.0	CNMG 322	N/A	CL-7	XNS-36	NL-33
945-000-044	945-000-046	MH16 MCLNR/L3	1.000	1.000	0.640	1.200	95.0	CNMG 322	N/A	CL-7	XNS-36	NL-33
945-000-045	945-000-047	MH16 MCLNR/L4	1.000	1.000	0.640	1.200	95.0	CNMG 432	N/A	CL-20	XNS-47	NL-44
945-000-096	945-000-097	MH20 MCLNR/L4	1.250	1.300	0.765	1.470	95.0	CNMG 432	ICSN-433	CL-20	XNS-47	NL-46
945-000-133	945-000-134	MH24 MCLNR/L4	1.500	1.520	.890	1.730	95.0	CNMG 432	ICSN-433	CL-20	XNS-47	NL-46
945-000-170	945-000-171	MH28 MCLNR/L4	1.750	1.770	1.015	1.995	95.0	CNMG 432	ICSN-433	CL-20	XNS-47	NL-46
945-000-200	945-000-202	MH32 MCLNR/L4	2.000	2.030	1.281	2.400	95.0	CNMG 432	ICSN-433	CL-20	XNS-47	NL-46
945-000-203	945-000-205	MH32 MCLNR/L5	2.000	2.030	1.281	2.400	95.0	CNMG 543	ICSN-533	CL-12	XNS-510	NL-58

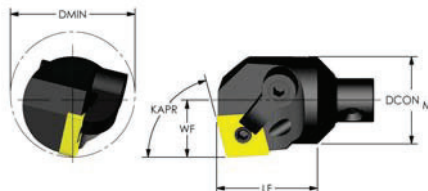

Negative 80° Diamond (KAPR: 75°)

Coolant Thru

PRODUCT # Left hand	PRODUCT # Right hand	Designation	DCON MS	LF	WF	DMIN	KAPR	Insert	Shim	Clamp	Clamp Screw	Lock Pin
945-000-003	945-000-004	MH12 MCKNR/L3	0.750	0.875	0.490	0.910	80.0	CNMG 322	N/A	CL-7	XNS-36	NL-33
945-000-042	945-000-043	MH16 MCKNR/L3	1.000	0.935	0.630	1.190	80.0	CNMG 322	N/A	CL-7	XNS-36	NL-33
945-000-094	945-000-096	MH20 MCKNR/L4	1.250	1.210	0.755	1.455	80.0	CNMG 432	ICSN-433	CL-20	XNS-47	NL-46
945-000-131	945-000-132	MH24 MCKNR/L4	1.500	1.430	0.880	1.720	80.0	CNMG 432	ICSN-433	CL-20	XNS-47	NL-46
945-000-168	945-000-169	MH28 MCKNR/L4	1.750	1.680	1.005	1.985	80.0	CNMG 432	ICSN-433	CL-20	XNS-47	NL-46
945-000-200	945-000-201	MH32 MCKNR/L4	2.000	1.940	1.271	2.390	80.0	CNMG 432	ICSN-433	CL-20	XNS-47	NL-46

PRODUCT #	Clamp Screw
968-000-176	XNS-36
968-000-177	XNS-47
968-000-178	XNS-48
968-000-179	XNS-510
968-000-180	XNS-58
968-000-181	XNS-59

PACKAGE SIZE OF 5

PRODUCT #	Lock Pin
968-000-097	NL-33
968-000-098	NL-33L
968-000-099	NL-34
968-000-100	NL-34L
968-000-101	NL-44
968-000-102	NL-46
968-000-103	NL-56
968-000-104	NL-58
968-000-105	NL-68
968-000-106	NL-68L

PACKAGE SIZE OF 5

ULTRA-DEX[®]

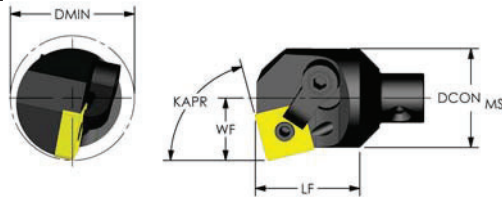

Negative Square (KAPR: 75°)

Coolant Thru

PRODUCT #	Designation	DCON MS	LF	WF	DMIN	KAPR	Insert	Shim	Clamp	Clamp Screw	Lock Pin
945-000-050	MH16 MSKNR4	1.000	1.060	0.630	1.190	75.0	SNMG 432	N/A	CL-20	XNS-47	NL-44
945-000-105	MH20 MSKNR4	1.250	1.210	0.755	1.455	75.0	SNMG 432	ISSN-432	CL-20	XNS-47	NL-46
945-000-141	MH24 MSKNR4	1.500	1.430	0.880	1.720	75.0	SNMG 432	ISSN-432	CL-20	XNS-47	NL-46
945-000-212	MH32 MSKNR4	2.000	1.680	1.271	2.390	75.0	SNMG 432	ISSN-432	CL-20	XNS-47	NL-46

MODULAR

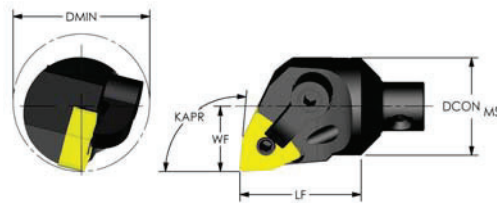

Negative Trigon (KAPR: 95°)

Coolant Thru

PRODUCT # Left hand	PRODUCT # Right hand	Designation	DCON MS	LF	WF	DMIN	KAPR	Insert	Shim	Clamp	Clamp Screw	Lock Pin
945-000-013	945-000-014	MH12 MWLNR/L3	0.750	0.940	0.500	0.920	95.0	WNMG 332	N/A	CL-7	XNS-36	NL-33L
945-000-057	945-000-058	MH16 MWLNR/L3	1.000	1.000	0.640	1.200	95.0	WNMG 332	N/A	CL-7	XNS-36	NL-33L
945-000-058	945-000-060	MH16 MWLNR/L4	1.000	1.000	0.640	1.240	95.0	WNMG 432	N/A	CL-20	XNS-47	NL-44
945-000-116	945-000-117	MH20 MWLNR/L4	1.250	1.300	0.765	1.470	95.0	WNMG 432	IWSN-433	CL-20	XNS-47	NL-46
945-000-152	945-000-153	MH24 MWLNR/L4	1.500	1.520	.890	1.730	95.0	WNMG 432	IWSN-433	CL-20	XNS-47	NL-46
945-000-186	945-000-187	MH28 MWLNR/L4	1.750	1.770	1.015	1.995	95.0	WNMG 432	IWSN-433	CL-20	XNS-47	NL-46
945-000-221	945-000-222	MH32 MWLNR/L4	2.000	2.030	1.281	2.400	95.0	WNMG 432	IWSN-433	CL-20	XNS-47	NL-46

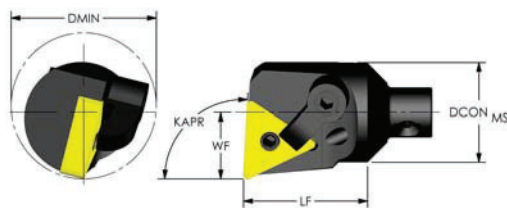

Negative Triangle (KAPR: 93°)

Coolant Thru

PRODUCT # Left hand	PRODUCT # Right hand	Designation	DCON MS	LF	WF	DMIN	KAPR	Insert	Shim	Clamp	Clamp Screw	Lock Pin
945-000-011	945-000-012	MH12 MTUNR/L3	0.750	0.940	0.500	0.920	93.0	TNMG 332	N/A	CL-7	XNS-36	NL-33L
945-000-053	945-000-054	MH16 MTUNR/L3	1.000	1.000	0.640	1.200	93.0	TNMG 332	N/A	CL-7	XNS-36	NL-33L
945-000-110	945-000-112	MH20 MTUNR/L3	1.250	1.300	0.765	1.470	93.0	TNMG 332	ITSN-323	CL-7	XNS-36	NL-34L
945-000-146	945-000-148	MH24 MTUNR/L3	1.500	1.520	0.890	1.470	93.0	TNMG 332	ITSN-323	CL-7	XNS-36	NL-34L
945-000-111	945-000-113	MH20 MTUNR/L4	1.250	1.300	0.765	1.730	93.0	TNMG 432	ITSN-433	CL-20	XNS-47	NL-46
945-000-147	945-000-149	MH24 MTUNR/L4	1.500	1.520	0.890	1.730	93.0	TNMG 432	ITSN-433	CL-20	XNS-47	NL-46
945-000-180	945-000-181	MH28 MTUNR/L4	1.750	1.770	1.015	1.995	93.0	TNMG 432	ITSN-433	CL-20	XNS-47	NL-46
945-000-215	945-000-216	MH32 MTUNR/L4	2.000	2.030	1.281	2.400	93.0	TNMG 432	ITSN-433	CL-20	XNS-47	NL-46

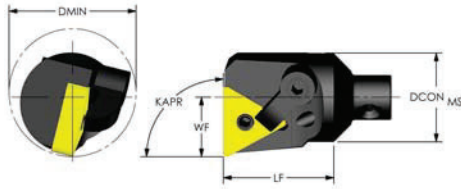

Negative Triangle (KAPR: 90°)



Coolant Thru

PRODUCT # Left hand	PRODUCT # Right hand	Designation	DCON MS	LF	WF	DMIN	KAPR	Insert	Shim	Clamp	Clamp Screw	Lock Pin
945-000-009	945-000-010	MH12 MTFNR/L3	0.750	0.940	0.500	0.920	90.0	TNMG 332	N/A	CL-7	XNS-36	NL-33L
945-000-051	945-000-052	MH16 MTFNR/L3	1.000	1.000	0.640	1.200	90.0	TNMG 332	N/A	CL-7	XNS-36	NL-33L
945-000-106	945-000-108	MH20 MTFNR/L3	1.250	1.300	0.765	1.470	90.0	TNMG 332	ITSN-323	CL-7	XNS-36	NL-34L
945-000-142	945-000-144	MH24 MTFNR/L3	1.500	1.520	0.890	1.730	90.0	TNMG 332	ITSN-323	CL-7	XNS-36	NL-34L
945-000-107	945-000-109	MH20 MTFNR/L4	1.250	1.300	0.765	1.470	90.0	TNMG 432	ITSN-433	CL-20	XNS-47	NL-46
945-000-143	945-000-145	MH24 MTFNR/L4	1.500	1.520	0.890	1.730	90.0	TNMG 432	ITSN-433	CL-20	XNS-47	NL-46
945-000-178	945-000-179	MH28 MTFNR/L4	1.750	1.770	1.015	1.995	90.0	TNMG 432	ITSN-433	CL-20	XNS-47	NL-46
945-000-213	945-000-214	MH32 MTFNR/L4	2.000	2.030	1.281	2.400	90.0	TNMG 432	ITSN-433	CL-20	XNS-47	NL-46

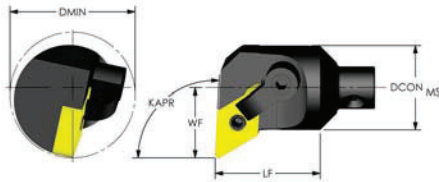

Negative 55° Diamond (KAPR: 93°) Profiling



Coolant Thru

PRODUCT # Left hand	PRODUCT # Right hand	Designation	DCON MS	LF	WF	DMIN	KAPR	Insert	Shim	Clamp	Clamp Screw	Lock Pin
945-000-007	945-000-008	MH12 MDUNR/L3	0.750	0.940	0.625	1.050	93.0	DNMG 332	N/A	CL-7	XNS-36	NL-33L
945-000-048	945-000-049	MH16 MDUNR/L3	1.000	1.000	0.750	1.310	93.0	DNMG 332	N/A	CL-7	XNS-36	NL-33L
N/A	945-000-102	MH20 MDUNR4-7	1.250	1.300	0.775	1.475	93.0	DNMG 432	IDSN-433	CL-22	XNS-48	NL-46
945-000-100	945-000-101	MH20 MDUNR/L4	1.250	1.300	1.000	1.700	93.0	DNMG 432	IDSN-433	CL-22	XNS-48	NL-46
945-000-137	945-000-138	MH24 MDUNR/L4	1.500	1.520	1.120	1.960	93.0	DNMG 432	IDSN-433	CL-22	XNS-48	NL-46
945-000-174	945-000-175	MH28 MDUNR/L4	1.750	1.770	1.250	2.250	93.0	DNMG 432	IDSN-433	CL-22	XNS-48	NL-46
945-000-208	945-000-209	MH32 MDUNR/L4	2.000	2.030	1.375	2.500	93.0	DNMG 432	IDSN-433	CL-22	XNS-48	NL-46

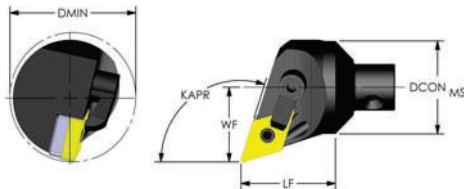

Negative 55° Diamond (KAPR: 107.5°) Profiling



Coolant Thru

PRODUCT # Left hand	PRODUCT # Right hand	Designation	DCON MS	LF	WF	DMIN	KAPR	Insert	Shim	Clamp	Clamp Screw	Lock Pin
945-000-098	945-000-099	MH20 MDQNR/L4	1.250	1.300	1.000	1.700	107.5	DNMG 432	IDSN-433	CL-22	XNS-48	NL-46
945-000-135	945-000-136	MH24 MDQNR/L4	1.500	1.520	1.120	1.960	107.5	DNMG 432	IDSN-433	CL-22	XNS-48	NL-46
945-000-172	945-000-173	MH28 MDQNR/L4	1.750	1.770	1.250	2.250	107.5	DNMG 432	IDSN-433	CL-22	XNS-48	NL-46
945-000-206	945-000-207	MH32 MDQNR/L4	2.000	2.030	1.281	2.400	107.5	DNMG 432	IDSN-433	CL-22	XNS-48	NL-46

ULTRA-DEX[®]

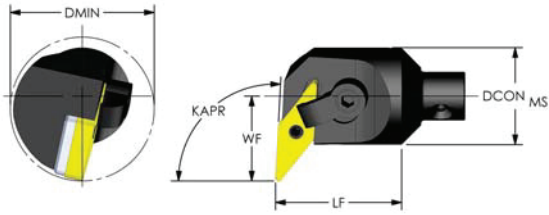

Negative 35° Diamond (KAPR: 93°) Profiling

Coolant Thru

PRODUCT # Left hand	PRODUCT # Right hand	Designation	DCON MS	LF	WF	DMIN	KAPR	Insert	Shim	Clamp	Clamp Screw	Lock Pin
945-000-055	945-000-056	MH16 MVUNR/L3	1.000	1.300	0.875	1.435	93.0	VNMG 332	IVSN-322	CL-20	XNS-47	NL- 34L
945-000-114	945-000-115	MH20 MVUNR/L3	1.250	1.300	1.000	1.700	93.0	VNMG 332	IVSN-322	CL-20	XNS-47	NL- 34L
945-000-150	945-000-151	MH24 MVUNR/L3	1.500	1.520	1.120	2.000	93.0	VNMG 332	IVSN-322	CL-20	XNS-47	NL -34L
945-000-182	945-000-181	MH28 MVUNR/L3	1.750	1.770	1.250	2.250	93.0	VNMG 332	IVSN-322	CL-20	XNS-47	NL -34L
945-000-217	945-000-216	MH32 MVUNR/L3	2.000	2.030	1.375	2.500	93.0	VNMG 332	IVSN-322	CL-20	XNS-47	NL-34L
945-000-183	945-000-185	MH28 MVUNR/L4	1.750	1.770	1.250	2.250	93.0	VNMG 432	IVSN-432	CL-22	XNS-48	NL-46
945-000-218	945-000-220	MH32 MVUNR/L4	2.000	2.030	1.375	2.500	93.0	VNMG 432	IVSN-432	CL-22	XNS-48	NL-46

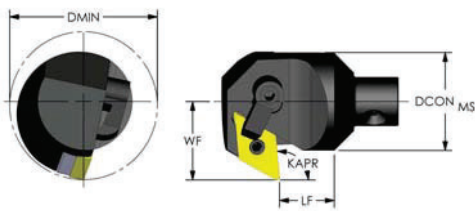

Negative 55° Diamond (KAPR: 95°) Back Facing

Coolant Thru

PRODUCT # Left hand	PRODUCT # Right hand	Designation	DCON MS	LF	WF	DMIN	KAPR	Insert	Shim	Clamp	Clamp Screw	Lock Pin
945-000-103	945-000-104	MH20 MDXNR/L4	1.250	0.700	1.000	1.700	95.0	DNMG 432	IDSN-433	CL-22	XNS-48	NL-46
945-000-139	945-000-140	MH24 MDXNR/L4	1.500	0.650	1.120	1.960	95.0	DNMG 432	IDSN-433	CL-22	XNS-48	NL-46
945-000-176	945-000-177	MH28 MDXNR/L4	1.750	0.780	1.250	2.250	95.0	DNMG 432	IDSN-433	CL-22	XNS-48	NL-46
945-000-210	945-000-211	MH32 MDXNR/L4	2.000	0.780	1.500	2.620	95.0	DNMG 432	IDSN-433	CL-22	XNS-48	NL-46

PRODUCT #	Clamp
968-000-016	CL-6
968-000-017	CL-7
968-000-020	CL-9
968-000-010	CL-12
968-000-011	CL-19
968-000-012	CL-20

PACKAGE SIZE OF 1

PRODUCT #	Clamp
968-000-013	CL-21
968-000-014	CL-22
968-000-015	CL-30
968-000-018	CL-84
968-000-019	CL-85

PACKAGE SIZE OF 1

PRODUCT #	Clamp Screw
968-000-176	XNS-36
968-000-177	XNS-47
968-000-178	XNS-48
968-000-179	XNS-510
968-000-180	XNS-58
968-000-181	XNS-59

PACKAGE SIZE OF 5

PRODUCT #	Lock Pin
968-000-097	NL-33
968-000-098	NL-33L
968-000-099	NL-34
968-000-100	NL-34L
968-000-101	NL-44
968-000-102	NL-46
968-000-103	NL-56
968-000-104	NL-58
968-000-105	NL-68
968-000-106	NL-68L

PACKAGE SIZE OF 5

MODULAR

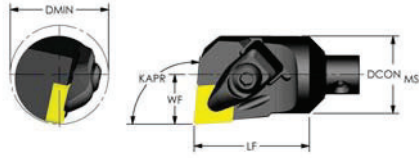

PULLBACK Clamp Negative 80° Diamond (KAPR: 95°)

Coolant Thru

PRODUCT #	Designation	DCON MS	LF	WF	DMIN	KAPR	Insert	Shim	Shim Screw	Clamp Assy.
945-000-039	MH16 DCLNR4	1.000	1.500	0.640	1.200	95.0	CNMG 432	N/A	N/A	PB4-CA
945-000-089	MH20 DCLNR4	1.250	1.500	0.765	1.470	95.0	CNMG 432	ICSN-433	PB4-SS	PB4-CA
945-000-126	MH24 DCLNR4	1.500	1.520	.890	1.730	95.0	CNMG 432	ICSN-433	PB4-SS	PB4-CA
945-000-163	MH28 DCLNR4	1.750	1.770	1.015	1.995	95.0	CNMG 432	ICSN-433	PB4-SS	PB4-CA
945-000-195	MH32 DCLNR4	2.000	2.030	1.281	2.400	95.0	CNMG 432	ICSN-433	PB4-SS	PB4-CA

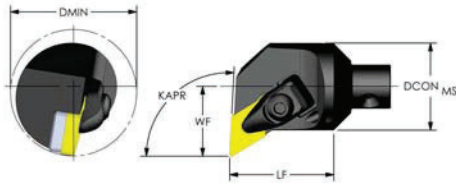

PULLBACK Clamp Negative 55° Diamond (KAPR: 93°)

Coolant Thru

PRODUCT #	Designation	DCON MS	LF	WF	DMIN	KAPR	Insert	Shim	Shim Screw	Clamp Assy.
945-000-090	MH20 DDUNR4	1.250	1.500	1.000	1.700	93.0	DNMG 432	IDSN-433	PB4-SS	PB4-CA
945-000-127	MH24 DDUNR4	1.500	1.520	1.120	1.960	93.0	DNMG 432	IDSN-433	PB4-SS	PB4-CA
945-000-164	MH28 DDUNR4	1.750	1.770	1.250	2.250	93.0	DNMG 432	IDSN-433	PB4-SS	PB4-CA
945-000-196	MH32 DDUNR4	2.000	2.030	1.375	2.500	93.0	DNMG 432	IDSN-433	PB4-SS	PB4-CA

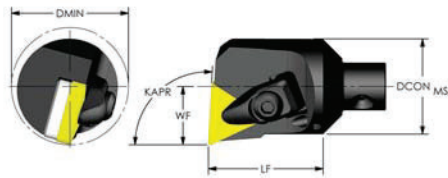

PULLBACK Clamp Negative Triangle (KAPR: 93°)

Coolant Thru

PRODUCT #	Designation	DCON MS	LF	WF	DMIN	KAPR	Insert	Shim	Shim Screw	Clamp Assy.
945-000-091	MH20 DTUNR4	1.250	1.500	0.765	1.470	93.0	TNMG 432	ITSN-433	PB4-SS	PB4-CA
945-000-128	MH24 DTUNR4	1.500	1.520	.890	1.730	93.0	TNMG 432	ITSN-433	PB4-SS	PB4-CA
945-000-165	MH28 DTUNR4	1.750	1.770	1.015	1.995	93.0	TNMG 432	ITSN-433	PB4-SS	PB4-CA
945-000-197	MH32 DTUNR4	2.000	2.030	1.281	2.400	93.0	TNMG 432	ITSN-433	PB4-SS	PB4-CA

PRODUCT #	Shim Screw
968-000-109	PB3-SS
968-000-111	PB4-SS

PACKAGE SIZE OF 5

PRODUCT #	Clamp Assy.
968-000-107	PB3-CA
968-000-110	PB4-CA

PACKAGE SIZE OF 1

ULTRA-DEX[®]

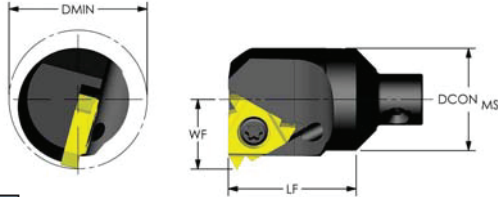

Threading / Grooving Laydown



Coolant Thru

PRODUCT #	Designation Right hand	DCON MS	LF	WF	DMIN	Insert	Insert Screw	Anvil Screw	Anvil
945-000-002	MH12 LSER3	0.750	0.940	0.510	0.930	3IR	MTS-35	N/A	N/A
945-000-041	MH16 LSER3	1.000	1.000	0.650	1.210	3IR	SA3T	SY3T	YI3
945-000-093	MH20 LSER3	1.250	1.300	0.770	1.470	3IR	SA3T	SY3T	YI3
945-000-130	MH24 LSER3	1.500	1.520	0.900	1.740	3IR	SA3T	SY3T	YI3
945-000-167	MH28 LSER3	1.750	1.770	1.090	2.070	3IR	SA3T	SY3T	YI3
945-000-199	MH32 LSER3	2.000	2.030	1.281	2.400	3IR	SA3T	SY3T	YI3

PRODUCT #	Designation Left hand	DCON MS	LF	WF	DMIN	Insert	Insert Screw	Anvil Screw	Anvil
945-000-001	MH12 LSEL3	0.750	0.940	0.510	0.930	3IL	MTS-35	N/A	N/A
945-000-040	MH16 LSEL3	1.000	1.000	0.650	1.210	3IL	SA3T	SY3T	YE3
945-000-092	MH20 LSEL3	1.250	1.300	0.770	1.470	3IL	SA3T	SY3T	YE3
945-000-129	MH24 LSEL3	1.500	1.520	0.900	1.740	3IL	SA3T	SY3T	YE3
945-000-166	MH28 LSEL3	1.750	1.770	1.090	2.070	3IL	SA3T	SY3T	YE3
945-000-198	MH32 LSEL3	2.000	2.030	1.281	2.400	3IL	SA3T	SY3T	YE3

PRODUCT #	Clamp
968-000-016	CL-6
968-000-017	CL-7
968-000-020	CL-9
968-000-010	CL-12
968-000-011	CL-19
968-000-012	CL-20

PACKAGE SIZE OF 1

PRODUCT #	Clamp
968-000-013	CL-21
968-000-014	CL-22
968-000-015	CL-30
968-000-018	CL-84
968-000-019	CL-85

PACKAGE SIZE OF 1

PRODUCT #	Anvil
968-000-185	YI3
968-000-182	YE3
968-000-187	YI4
968-000-186	YI3M-1.5N
968-000-183	YE4
968-000-188	YI5
968-000-184	YE5

PACKAGE SIZE OF 1

PRODUCT #	Anvil Screw
968-000-146	SY3T
968-000-147	SY4T
968-000-148	SY5T

PACKAGE SIZE OF 5

PRODUCT #	Insert Screw
968-000-124	SA3T
968-000-125	SA4T
968-000-126	SA5T

PACKAGE SIZE OF 5

MODULAR

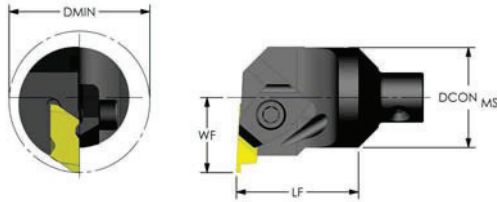

Threading / Grooving Top Notch



Coolant Thru

PRODUCT # Right hand	Designation	DCON MS	LF	WF	DMIN	Insert	Clamp	Clamp Screw
945-000-016	MH12 NER2	0.750	0.920	0.562	1.120	NG 2L	CM-75	6-32
945-000-063	MH16 NER2	1.000	1.180	0.688	1.380	NG 2L	CM-75	6-32
945-000-064	MH16 NER3	1.000	1.180	0.688	1.380	NG 3L	CM-73	10-32
945-000-119	MH20 NER3	1.250	1.300	0.875	1.750	NG 3L	CM-73	10-32
945-000-155	MH24 NER3	1.500	1.520	1.000	2.000	NG 3L	CM-73	10-32
945-000-189	MH28 NER3	1.750	1.770	1.125	2.250	NG 3L	CM-73	10-32
945-000-224	MH32 NER3	2.000	2.030	1.250	2.500	NG 3L	CM-73	10-32

PRODUCT # Left hand	Designation	DCON MS	LF	WF	DMIN	Insert	Clamp	Clamp Screw
945-000-015	MH12 NEL2	0.750	0.920	0.562	1.120	NG 2R	CM-74	6-32
945-000-061	MH16 NEL2	1.000	1.180	0.688	1.380	NG 2R	CM-74	6-32
945-000-062	MH16 NEL3	1.000	1.180	0.688	1.380	NG 3R	CM-72	10-32
945-000-118	MH20 NEL3	1.250	1.300	0.875	1.750	NG 3R	CM-72	10-32
945-000-154	MH24 NEL3	1.500	1.520	1.000	2.000	NG 3R	CM-72	10-32
945-000-188	MH28 NEL3	1.750	1.770	1.125	2.250	NG 3R	CM-72	10-32
945-000-223	MH32 NEL3	2.000	2.030	1.250	2.500	NG 3R	CM-72	10-32

PRODUCT #	Clamp
968-000-025	CM-72
968-000-026	CM-73
968-000-027	CM-74
968-000-028	CM-75
968-000-021	CM-120
968-000-022	CM-121
968-000-023	CM-146
968-000-024	CM-147

PACKAGE SIZE OF 1

PRODUCT #	Clamp Screw
968-000-005	6-32
968-000-003	10-32
968-000-096	MTS-526

PACKAGE SIZE OF 5

MODULAR

STEALTH™ BORING BARS

Tunable Internal Damping Technology



5:1 Up To
14:1 Ratio

0.500" - 4.00" Diameters



Product Highlights:

Tunable Internal Damping Technology provides optimal dynamic stability yielding significant increases in machining performance. Most importantly, the bars pay for themselves quickly by increasing speed and precision. Additionally, you can leave Stealth Tooling "CFT" in the machine and use it for deep or shallow bore applications, thus reducing changeover and setup time.

- Fully tunable boring bar (arrives pre-tuned)
- Labeled dial for ease of tuning
- Quick setup flat located on connection end of bar
- Solves difficult deep boring applications
- Improved surface finish
- Increase output by more aggressive cutting
- Increase tool life from reduced vibration
- Multiple head configurations

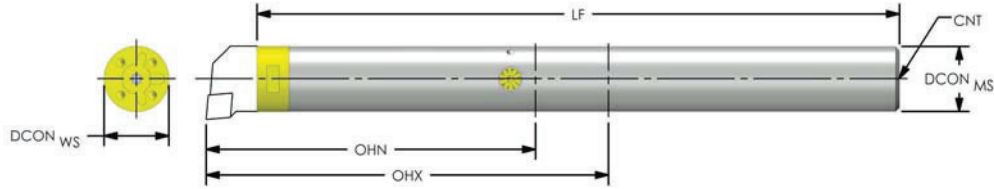

5:1 Ratio

Modular Stealth™ Bars

Coolant Thru

PRODUCT #	Designation	DCON MS	DCON WS	LF	OHN	OHX	Head Bolts	CNT
910-000-013	CFT B1500-9	1.500	1.500	9.000	7.000	7.500	10-24 HB	1/8-27 NPT
910-000-018	CFT B2000-12	2.000	2.000	12.000	7.500	10.000	1/4-20 HB	1/8-27 NPT
910-000-023	CFT B2500-16	2.500	2.500	16.000	8.000	12.500	5/16-18 HB	1/8-27 NPT

7:1 Ratio

910-000-001	CFT B1000-10	1.000	1.000	10.000	5.000	7.000	8-32 HB	1/8-27 NPT
910-000-005	CFT B1250-12	1.250	1.250	12.000	6.250	8.750	10-24 HB	1/8-27 NPT
910-000-009	CFT B1500-15	1.500	1.500	15.000	7.500	10.500	10-24 HB	1/8-27 NPT
910-000-014	CFT B1750-18	1.750	1.750	18.000	8.750	12.250	1/4-20 HB	1/8-27 NPT
910-000-019	CFT B2000-20	2.000	2.000	20.000	10.000	14.000	1/4-20 HB	1/8-27 NPT
910-000-024	CFT B2500-27	2.500	2.500	27.000	12.500	17.500	5/16-18 HB	1/4-18 NPT
910-000-028	CFT B3000-31	3.000	2.500	31.000	15.000	21.000	5/16-18 HB	1/4-18 NPT

10:1 Ratio

910-000-002	CFT B1000-14	1.000	1.000	14.000	7.000	10.000	8-32 HB	1/8-27 NPT
910-000-006	CFT B1250-16	1.250	1.250	16.000	8.750	12.500	10-24 HB	1/8-27 NPT
910-000-010	CFT B1500-19	1.500	1.500	19.000	10.500	15.000	10-24 HB	1/8-27 NPT
910-000-015	CFT B1750-23	1.750	1.750	23.000	12.250	17.500	1/4-20 HB	1/8-27 NPT
910-000-020	CFT B2000-26	2.000	2.000	26.000	14.000	20.000	1/4-20 HB	1/8-27 NPT
910-000-025	CFT B2500-33	2.500	2.500	33.000	17.500	25.000	5/16-18 HB	1/4-18 NPT
910-000-029	CFT B3000-40	3.000	2.500	40.000	21.000	30.000	5/16-18 HB	1/4-18 NPT
910-000-034	CFT B4000-50	4.000	2.500	50.000	28.000	40.000	5/16-18 HB	1/4-18 NPT

12:1 Ratio

910-000-003	CFT B1000-16	1.000	1.000	16.000	10.875	12.000	8-32 HB	N/A
910-000-058	CFT B1250-18	1.250	1.250	18.000	13.785	15.000	10-24 HB	N/A
910-000-011	CFT B1500-22	1.500	1.500	22.000	16.375	18.000	10-24 HB	N/A
910-000-016	CFT B1750-25	1.750	1.750	25.000	18.060	21.000	1/4-20 HB	N/A
910-000-021	CFT B2000-29	2.000	2.000	29.000	19.375	24.000	1/4-20 HB	N/A

14:1 Ratio

910-000-004	CFT B1000-18	1.000	1.000	18.000	10.875	12.000	8-32 HB	N/A
910-000-008	CFT B1250-21	1.250	1.250	21.000	13.875	15.000	10-24 HB	N/A
910-000-012	CFT B1500-25	1.500	1.500	25.000	16.375	18.000	10-24 HB	N/A
910-000-017	CFT B1750-29	1.750	1.750	29.000	18.060	21.000	1/4-20 HB	N/A
910-000-022	CFT B2000-33	2.000	2.000	33.000	19.375	24.000	1/4-20 HB	N/A

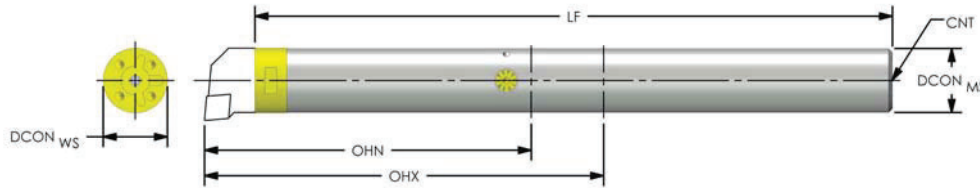

7:1 Ratio

Modular Stealth™ Bars

Coolant Thru

PRODUCT #	Designation	DCON MS	DCON WS	LF	OHN	OHX	Head Bolts	CNT
910-000-077	CFT B25MM-250	25mm	1.000	250mm	127mm	175mm	8-32 HB	1/8-27 NPT
910-000-079	CFT B32MM-320	32mm	1.250	320mm	159mm	224mm	10-24 HB	1/8-27 NPT
910-000-083	CFT B40MM-400	40mm	1.500	400mm	190mm	280mm	10-24 HB	1/8-27 NPT
910-000-087	CFT B50MM-500	50mm	2.000	500mm	254mm	350mm	1/4-20 HB	1/8-27 NPT
910-000-091	CFT B60MM-600	60mm	2.000	600mm	320mm	420mm	1/4-20 HB	1/8-27 NPT

10:1 Ratio

910-000-078	CFT B25MM-325	25mm	1.000	325mm	178mm	250mm	8-32 HB	1/8-27 NPT
910-000-080	CFT B32MM-416	32mm	1.250	416mm	223mm	320mm	10-24 HB	1/8-27 NPT
910-000-084	CFT B40MM-520	40mm	1.500	520mm	266mm	400mm	10-24 HB	1/8-27 NPT
910-000-088	CFT B50MM-650	50mm	2.000	650mm	356mm	500mm	1/4-20 HB	1/8-27 NPT
910-000-092	CFT B60MM-780	60mm	2.000	780mm	445mm	600mm	1/4-20 HB	1/8-27 NPT

12:1 Ratio

910-000-081	CFT B32MM-480	32mm	1.250	480mm	352mm	384mm	10-24 HB	N/A
910-000-085	CFT B40MM-600	40mm	1.500	600mm	416mm	480mm	10-24 HB	N/A
910-000-089	CFT B50MM-750	50mm	2.000	750mm	492mm	600mm	1/4-20 HB	N/A

14:1 Ratio

910-000-082	CFT B32MM-544	32mm	1.250	544mm	352mm	448mm	10-24 HB	N/A
910-000-086	CFT B40MM-680	40mm	1.500	680mm	416mm	560mm	10-24 HB	N/A
910-000-090	CFT B50MM-850	50mm	2.000	850mm	492mm	788mm	1/4-20 HB	N/A

PRODUCT #	Head Bolts
968-000-006	8-32 HB
968-000-002	10-24 HB
968-000-001	1/4-20 HB
968-000-004	5/16-18 HB

PACKAGE SIZE OF 1

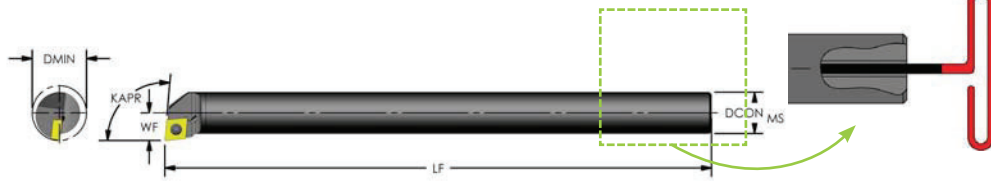

Tuneable from the end with supplied T-Handle Hex Wrench.

8:1 Ratio
Coolant Thru

SOLID Positive 80° Diamond (KAPR: 95°)

PRODUCT #	Designation	DCON MS	LF	WF	DMIN	KAPR	Insert	Insert Screw	Key
910-000-045	D08R SCLCR2	0.500	8.000	0.281	0.580	95.0	CCMT 21.51	MTS-255	T-7
910-000-047	D10X SCLCR3	0.625	9.000	0.406	0.770	95.0	CCMT 32.51	MTS-35	T-15
910-000-050	D12S SCLCR3	0.750	10.000	0.500	0.930	95.0	CCMT 32.51	MTS-35	T-15

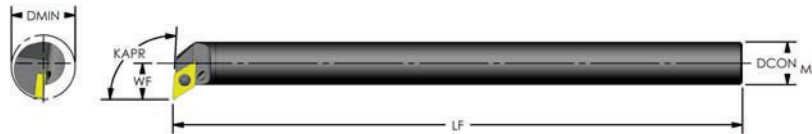

Tuneable from the end with supplied T-Handle Hex Wrench.

8:1 Ratio
Coolant Thru

SOLID Positive 55° Diamond (KAPR: 93°)

PRODUCT #	Designation	DCON MS	LF	WF	DMIN	KAPR	Insert	Insert Screw	Key
910-000-046	D08R SDUCR2	0.500	8.000	0.437	0.730	93.0	DCMT 21.51	MTS-255	T-7
910-000-048	D10X SDUCR2	0.625	9.000	0.500	0.850	93.0	DCMT 21.51	MTS-255	T-7
910-000-051	D12S SDUCR3	0.750	10.000	0.625	1.050	93.0	DCMT 32.51	MTS-35	T-15

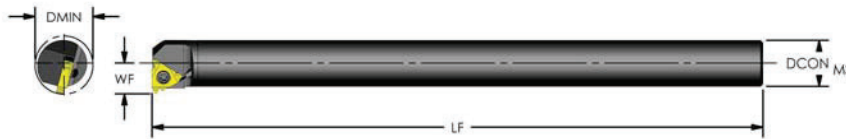

Tuneable from the end with supplied T-Handle Hex Wrench.

8:1 Ratio
Coolant Thru

SOLID Threading/Grooving Laydown

PRODUCT #	Designation	DCON MS	LF	WF	DMIN	Insert	Insert Screw
910-000-049	D12S LSER3	0.750	10.000	0.510	0.935	3IR	MTS-35

PRODUCT #	Insert Screws
968-000-086	MTS-183
968-000-087	MTS-184
968-000-088	MTS-2
968-000-091	MTS-224
968-000-092	MTS-255
968-000-094	MTS-35
968-000-090	MTS-2.5L
968-000-052	ETS 4-40

PACKAGE SIZE OF 5

PRODUCT #	Key
968-000-156	T-6
968-000-158	T-7
968-000-149	T-10
968-000-151	T-15
968-000-153	T-20

PACKAGE SIZE OF 5

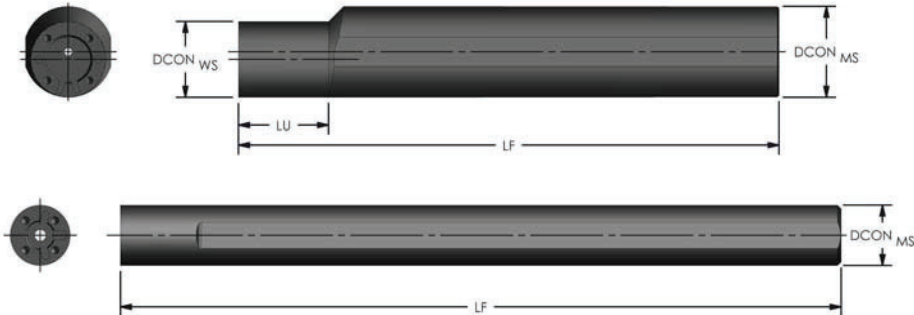

STEEL SHANK

4:1 Ratio
Coolant Thru

PRODUCT #	Designation	DCON MS	DCON WS	LU	LF	Head Bolts
911-000-001	A1000-12	1.000	N/A	N/A	12.000	8-32
911-000-002	A1250-14	1.250	N/A	N/A	14.000	10-24
911-000-003	A1500-14	1.500	N/A	N/A	14.000	10-24
911-000-004	A1750-16	1.750	N/A	N/A	16.000	1/4-20
911-000-026	A2000-10	2.000	N/A	N/A	10.000	1/4-20
911-000-005	A2000-20	2.000	N/A	N/A	20.000	1/4-20
911-000-006	A2500-12	2.500	N/A	N/A	12.000	5/16-18
911-000-007	A2500-24	2.500	N/A	N/A	24.000	5/16-18
911-000-008	A3000-18 *	3.000	2.000	3.000	18.000	5/16-18

* 3" bar takes 2.5" head

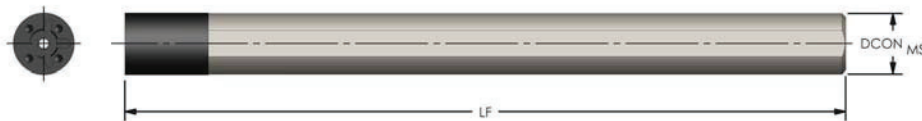

CARBIDE SHANK

8:1 Ratio
Coolant Thru

PRODUCT #	Designation	DCONMS	LF	Head Bolts
911-000-016	E1000-12	1.000	12.000	8-32
911-000-017	E1250-14	1.250	14.000	10-24
911-000-018	E1500-14	1.500	14.000	10-24
911-000-019	E1750-16	1.750	16.000	1/4-20
911-000-020	E2000-20	2.000	20.000	1/4-20

PRODUCT #	Head Bolts
968-000-006	8-32 HB
968-000-002	10-24 HB
968-000-001	1/4-20 HB
968-000-004	5/16-18 HB

PACKAGE SIZE OF 1

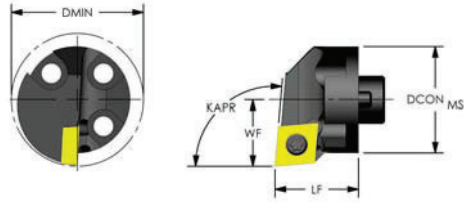

Positive 80° Diamond (KAPR: 93°)

Coolant Thru

PRODUCT # Left hand	PRODUCT # Right hand	Designation	DCON MS	LF	WF	DMIN	KAPR	Insert	Insert Screw	Key
912-000-014	912-000-015	MH16 SCLCR/L3-CFT	1.000	0.790	0.625	1.200	93.0	CCMT 32.51	MTS-35	T-15
912-000-041	912-000-042	MH20 SCLCR/L3-CFT	1.250	1.250	0.765	1.470	93.0	CCMT 32.51	MTS-35	T-15
912-000-074	912-000-075	MH24 SCLCR/L3-CFT	1.500	1.250	0.890	1.760	93.0	CCMT 32.51	MTS-35	T-15
912-000-110	912-000-111	MH28 SCLCR/L3-CFT	1.750	1.250	1.015	2.030	93.0	CCMT 32.51	MTS-35	T-15
N/A	912-000-076	MH24 SCLCR4-CFT	1.500	1.250	0.890	1.760	93.0	CCMT 432	MTS-4	T-20
N/A	912-000-112	MH28 SCLCR4-CFT	1.750	1.250	1.015	2.030	93.0	CCMT 432	MTS-4	T-20
912-000-156	912-000-157	MH32 SCLCR/L4-CFT	2.000	1.625	1.281	2.400	93.0	CCMT 432	MTS-4	T-20
912-000-195	912-000-196	MH40 SCLCR/L4-CFT	2.500	1.625	1.500	2.800	93.0	CCMT 432	MTS-4	T-20

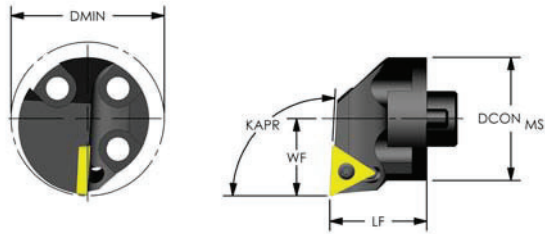

Positive Triangle (KAPR: 93°)

Coolant Thru

PRODUCT # Left hand	PRODUCT # Right hand	Designation	DCON MS	LF	WF	DMIN	KAPR	Insert	Insert Screw	Key
912-000-020	912-000-021	MH16 STUCR/L2-CFT	1.000	0.790	0.625	1.200	93.0	TCMT 21.51	MTS-255	T-7
912-000-047	912-000-048	MH20 STUCR/L3-CFT	1.250	1.250	0.765	1.470	93.0	TCMT 32.51	MTS-35	T-15
912-000-081	912-000-082	MH24 STUCR/L3-CFT	1.500	1.250	0.890	1.760	93.0	TCMT 32.51	MTS-35	T-15
912-000-117	912-000-118	MH28 STUCR/L3-CFT	1.750	1.250	1.015	2.030	93.0	TCMT 32.51	MTS-35	T-15
912-000-162	912-000-163	MH32 STUCR/L3-CFT	2.000	1.625	1.281	2.400	93.0	TCMT 32.51	MTS-35	T-15
912-000-201	912-000-202	MH40 STUCR/L3-CFT	2.500	1.625	1.500	2.800	93.0	TCMT 32.51	MTS-35	T-15

PRODUCT #	Insert Screws
968-000-086	MTS-183
968-000-087	MTS-184
968-000-088	MTS-2
968-000-091	MTS-224
968-000-092	MTS-255
968-000-094	MTS-35
968-000-090	MTS-2.5L
968-000-052	ETS 4-40

PACKAGE SIZE OF 5

PRODUCT #	Key
968-000-156	T-6
968-000-158	T-7
968-000-149	T-10
968-000-151	T-15
968-000-153	T-20

PACKAGE SIZE OF 5

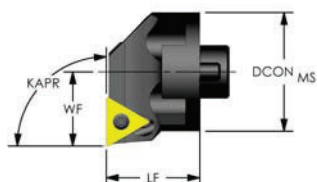
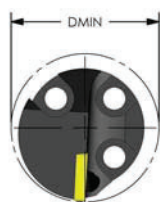

Positive Triangle (KAPR: 90°)



Coolant Thru

PRODUCT # Left hand	PRODUCT # Right hand	Designation	DCON MS	LF	WF	DMIN	KAPR	Insert	Insert Screw	Key
912-000-018	912-000-019	MH16 STFCLR/L2-CFT	1.000	0.790	0.625	1.200	90.0	TCMT 21.51	MTS-255	T-7
912-000-045	912-000-046	MH20 STFCLR/L3-CFT	1.250	1.250	0.765	1.470	90.0	TCMT 32.51	MTS-35	T-15
912-000-079	912-000-080	MH24 STFCLR/L3-CFT	1.500	1.250	0.890	1.760	90.0	TCMT 32.51	MTS-35	T-15
912-000-115	912-000-116	MH28 STFCLR/L3-CFT	1.750	1.250	1.015	2.030	90.0	TCMT 32.51	MTS-35	T-15
912-000-160	912-000-161	MH32 STFCLR/L3-CFT	2.000	1.625	1.281	2.400	90.0	TCMT 32.51	MTS-35	T-15
912-000-199	912-000-200	MH40 STFCLR/L3-CFT	2.500	1.625	1.500	2.800	90.0	TCMT 32.51	MTS-35	T-15

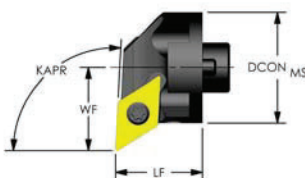
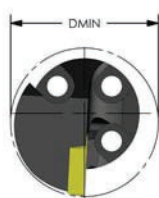

Positive 55° Diamond (KAPR: 93°) Profiling



Coolant Thru

PRODUCT # Left hand	PRODUCT # Right hand	Designation	DCON MS	LF	WF	DMIN	KAPR	Insert	Insert Screw	Key
912-000-016	912-000-017	MH16 SDUCR/L3-CFT	1.000	0.790	0.750	1.300	93.0	DCMT 32.51	MTS-35	T-15
912-000-043	912-000-044	MH20 SDUCR/L3-CFT	1.250	1.250	1.000	1.675	93.0	DCMT 32.51	MTS-35	T-15
912-000-077	912-000-078	MH24 SDUCR/L3-CFT	1.500	1.250	1.120	1.920	93.0	DCMT 32.51	MTS-35	T-15
912-000-113	912-000-114	MH28 SDUCR/L3-CFT	1.750	1.250	1.250	2.175	93.0	DCMT 32.51	MTS-35	T-15
912-000-158	912-000-159	MH32 SDUCR/L3-CFT	2.000	1.625	1.375	2.425	93.0	DCMT 32.51	MTS-35	T-15
912-000-197	912-000-198	MH40 SDUCR/L3-CFT	2.500	1.625	1.500	2.800	93.0	DCMT 32.51	MTS-35	T-15

PRODUCT #	Insert Screws
968-000-086	MTS-183
968-000-087	MTS-184
968-000-088	MTS-2
968-000-091	MTS-224
968-000-092	MTS-255
968-000-094	MTS-35
968-000-090	MTS-2.5L
968-000-052	ETS 4-40

PACKAGE SIZE OF 5

PRODUCT #	Key
968-000-156	T-6
968-000-158	T-7
968-000-149	T-10
968-000-151	T-15
968-000-153	T-20

PACKAGE SIZE OF 5

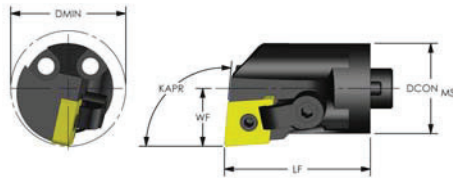

Negative 80° Diamond (KAPR: 95°)

Coolant Thru

PRODUCT # Left hand	PRODUCT # Right hand	Designation	DCON MS	LF	WF	DMIN	KAPR	Insert	Shim	Clamp	Clamp Screw	Lock Pin
912-000-003	912-000-004	MH16 MCLNR/L4-CFT	1.000	1.625	0.640	1.200	95.0	CNMG 432	N/A	CL-20	XNS-47	NL-44
912-000-024	912-000-025	MH20 MCLNR/L4-CFT	1.250	1.625	0.765	1.470	95.0	CNMG 432	ICSN-433	CL-20	XNS-47	NL-46
912-000-053	912-000-055	MH24 MCLNR/L4-CFT	1.500	1.625	0.890	1.760	95.0	CNMG 432	ICSN-433	CL-20	XNS-47	NL-46
912-000-087	912-000-088	MH28 MCLNR/L4-CFT	1.750	1.625	1.015	2.010	95.0	CNMG 432	ICSN-433	CL-20	XNS-47	NL-46
912-000-125	912-000-128	MH32 MCLNR/L4-CFT	2.000	1.625	1.281	2.400	95.0	CNMG 432	ICSN-433	CL-20	XNS-47	NL-46
912-000-166	912-000-169	MH40 MCLNR/L4-CFT	2.500	1.625	1.531	2.980	95.0	CNMG 432	ICSN-433	CL-20	XNS-47	NL-46
912-000-054	912-000-056	MH24 MCLNR/L5-CFT	1.250	1.625	0.890	1.760	95.0	CNMG 543	N/A	CL-20	XNS-47	NL-56
912-000-126	912-000-129	MH32 MCLNR/L5-CFT	2.000	1.625	1.281	2.400	95.0	CNMG 543	ICSN-533	CL-12	XNS-510	NL-58
912-000-167	912-000-170	MH40 MCLNR/L5-CFT	2.500	1.625	1.531	2.980	95.0	CNMG 543	ICSN-533	CL-12	XNS-510	NL-58
912-000-127	912-000-130	MH32 MCLNR/L6-CFT	2.000	1.625	1.281	2.400	95.0	CNMG 643	ICSN-633	CL-12	XNS-59	NL-68
912-000-168	912-000-171	MH40 MCLNR/L6-CFT	2.500	1.625	1.531	3.030	95.0	CNMG 643	ICSN-633	CL-12	XNS-59	NL-68

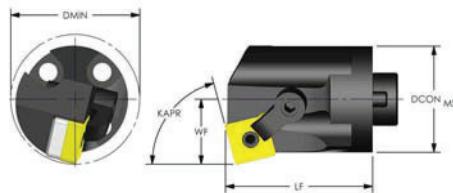

Negative Square (KAPR: 75°)

Coolant Thru

PRODUCT # Left hand	PRODUCT # Right hand	Designation	DCON MS	LF	WF	DMIN	KAPR	Insert	Shim	Clamp	Clamp Screw	Lock Pin
912-000-030	912-000-031	MH20 MSKNR/L4-CFT	1.250	1.744	0.765	1.470	75.0	SNMG 432	ISSN-433	CL-20	XNS-47	NL-46
912-000-061	912-000-062	MH24 MSKNR/L4-CFT	1.500	1.744	0.890	1.760	75.0	SNMG 432	ISSN-433	CL-20	XNS-47	NL-46
912-000-093	912-000-094	MH28 MSKNR/L4-CFT	1.750	1.744	1.015	2.010	75.0	SNMG 432	ISSN-433	CL-20	XNS-47	NL-46
912-000-135	912-000-138	MH32 MSKNR/L4-CFT	2.000	1.744	1.281	2.400	75.0	SNMG 432	ISSN-433	CL-20	XNS-47	NL-46
912-000-176	912-000-179	MH40 MSKNR/L4-CFT	2.500	1.804	1.531	3.030	75.0	SNMG 432	ISSN-433	CL-20	XNS-47	NL-46
912-000-136	912-000-139	MH32 MSKNR/L5-CFT	2.000	1.744	1.281	2.400	75.0	SNMG 543	ISSN-533	CL-12	XNS-510	NL-58
912-000-177	912-000-180	MH40 MSKNR/L5-CFT	2.500	1.804	1.531	3.030	75.0	SNMG 543	ISSN-533	CL-12	XNS-510	NL-58
912-000-137	912-000-138	MH32 MSKNR/L6-CFT	2.000	1.744	1.281	2.400	75.0	SNMG 643	ISSN-633	CL-12	XNS-510	NL-68
912-000-178	912-000-181	MH40 MSKNR/L6-CFT	2.500	1.804	1.531	3.030	75.0	SNMG 643	ISSN-633	CL-12	XNS-510	NL-68

PRODUCT #	Clamp
968-000-016	CL-6
968-000-017	CL-7
968-000-020	CL-9
968-000-010	CL-12
968-000-011	CL-19
968-000-012	CL-20

PACKAGE SIZE OF 1

PRODUCT #	Clamp
968-000-013	CL-21
968-000-014	CL-22
968-000-015	CL-30
968-000-018	CL-84
968-000-019	CL-85

PACKAGE SIZE OF 1

PRODUCT #	Clamp Screw
968-000-176	XNS-36
968-000-177	XNS-47
968-000-178	XNS-48
968-000-179	XNS-510
968-000-180	XNS-58
968-000-181	XNS-59

PACKAGE SIZE OF 5

PRODUCT #	Lock Pin
968-000-097	NL-33
968-000-098	NL-33L
968-000-099	NL-34
968-000-100	NL-34L
968-000-101	NL-44
968-000-102	NL-46
968-000-103	NL-56
968-000-104	NL-58
968-000-105	NL-68
968-000-106	NL-68L

PACKAGE SIZE OF 5

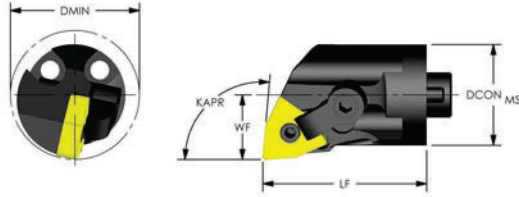

Negative Trigon (KAPR: 95°)

Coolant Thru



PRODUCT # Left hand	PRODUCT # Right hand	Designation	DCON MS	LF	WF	DMIN	KAPR	Insert	Shim	Clamp	Clamp Screw	Lock Pin
912-000-012	912-000-013	MH16 MWLNR/L4-CFT	1.000	1.625	0.640	1.200	95.0	WNMG 432	N/A	CL-20	XNS-47	NL-44
912-000-037	912-000-038	MH20 MWLNR/L4-CFT	1.250	1.625	0.765	1.470	95.0	WNMG 432	IWSN-433	CL-20	XNS-47	NL-46
912-000-070	912-000-071	MH24 MWLNR/L4-CFT	1.500	1.625	0.890	1.760	95.0	WNMG 432	IWSN-433	CL-20	XNS-47	NL-46
912-000-102	912-000-103	MH28 MWLNR/L4-CFT	1.750	1.625	1.015	2.010	95.0	WNMG 432	IWSN-433	CL-20	XNS-47	NL-46
912-000-148	912-000-149	MH32 MWLNR/L4-CFT	2.000	1.625	1.281	2.400	95.0	WNMG 432	IWSN-433	CL-20	XNS-47	NL-46
912-000-189	912-000-190	MH40 MWLNR/L4-CFT	2.500	1.625	1.500	2.980	95.0	WNMG 432	IWSN-433	CL-20	XNS-47	NL-46

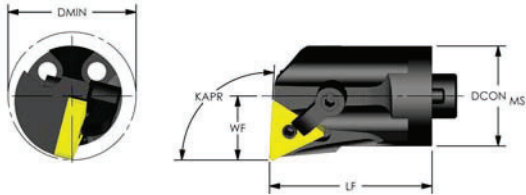

Negative Triangle (KAPR: 93°)

Coolant Thru



PRODUCT #	Designation	DCON MS	LF	WF	DMIN	KAPR	Insert	Shim	Clamp	Clamp Screw	Lock Pin
912-000-007	MH16 MTUNR3-CFT	1.000	1.625	0.640	1.200	93.0	TNMG 332	N/A	CL-7	XNS-36	NL-33L
912-000-032	MH20 MTUNR3-CFT	1.250	1.625	0.765	1.470	93.0	TNMG 332	ITSN-323	CL-7	XNS-36	NL-34L
912-000-065	MH24 MTUNR4-CFT	1.500	1.625	0.890	1.760	93.0	TNMG 432	ITSN-433	CL-20	XNS-47	NL-46
912-000-097	MH28 MTUNR4-CFT	1.750	1.625	1.015	2.010	93.0	TNMG 432	ITSN-433	CL-20	XNS-47	NL-46
912-000-143	MH32 MTUNR4-CFT	2.000	1.625	1.281	2.400	93.0	TNMG 432	ITSN-433	CL-20	XNS-47	NL-46
912-000-182	MH40 MTUNR4-CFT	2.500	1.625	1.531	2.900	93.0	TNMG 432	ITSN-433	CL-20	XNS-47	NL-46

PRODUCT #	Clamp
968-000-016	CL-6
968-000-017	CL-7
968-000-020	CL-9
968-000-010	CL-12
968-000-011	CL-19
968-000-012	CL-20

PACKAGE SIZE OF 1

PRODUCT #	Clamp
968-000-013	CL-21
968-000-014	CL-22
968-000-015	CL-30
968-000-018	CL-84
968-000-019	CL-85

PACKAGE SIZE OF 1

PRODUCT #	Clamp Screw
968-000-176	XNS-36
968-000-177	XNS-47
968-000-178	XNS-48
968-000-179	XNS-510
968-000-180	XNS-58
968-000-181	XNS-59

PACKAGE SIZE OF 5

PRODUCT #	Lock Pin
968-000-097	NL-33
968-000-098	NL-33L
968-000-099	NL-34
968-000-100	NL-34L
968-000-101	NL-44
968-000-102	NL-46
968-000-103	NL-56
968-000-104	NL-58
968-000-105	NL-68
968-000-106	NL-68L

PACKAGE SIZE OF 5

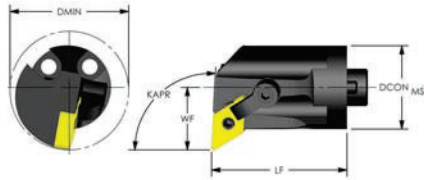

Negative 55° Diamond (KAPR: 93°)



Coolant Thru

PRODUCT # Left hand	PRODUCT # Right hand	Designation	DCON MS	LF	WF	DMIN	KAPR	Insert	Shim	Clamp	Clamp Screw	Lock Pin
912-000-005	912-000-006	MH16 MDUNR/L3-CFT	1.000	1.625	0.750	1.300	93.0	DNMG 332	N/A	CL-7	XNS-36	NL-33L
912-000-026	912-000-027	MH20 MDUNR/L3-CFT	1.250	1.625	1.000	1.705	93.0	DNMG 332	IDSN-322	CL-7	XNS-36	NL-34L
912-000-057	912-000-059	MH24 MDUNR/L3-CFT	1.500	1.625	1.125	2.000	93.0	DNMG 332	IDSN-322	CL-7	XNS-36	NL-34L
912-000-089	912-000-091	MH28 MDUNR/L3-CFT	1.750	1.625	1.250	2.250	93.0	DNMG 332	IDSN-322	CL-7	XNS-36	NL-34L
912-000-131	912-000-133	MH32 MDUNR/L3-CFT	2.000	1.625	1.375	2.500	93.0	DNMG 332	IDSN-322	CL-7	XNS-36	NL-34L
912-000-172	912-000-174	MH40 MDUNR/L3-CFT	2.500	1.625	1.500	2.950	93.0	DNMG 332	IDSN-322	CL-7	XNS-36	NL-34L
912-000-027	912-000-029	MH20 MDUNR/L4-CFT	1.250	1.625	1.000	1.705	93.0	DNMG 432	IDSN-433	CL-20	XNS-48	NL-46
912-000-058	912-000-060	MH24 MDUNR/L4-CFT	1.500	1.625	1.125	2.000	93.0	DNMG 432	IDSN-433	CL-22	XNS-48	NL-46
912-000-090	912-000-092	MH28 MDUNR/L4-CFT	1.750	1.625	1.250	2.250	93.0	DNMG 432	IDSN-433	CL-22	XNS-48	NL-46
912-000-132	912-000-134	MH32 MDUNR/L4-CFT	2.000	1.625	1.375	2.500	93.0	DNMG 432	IDSN-433	CL-22	XNS-48	NL-46
912-000-173	912-000-175	MH40 MDUNR/L4-CFT	2.500	1.625	1.500	2.950	93.0	DNMG 432	IDSN-433	CL-22	XNS-48	NL-46

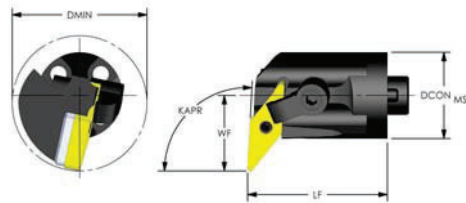

Negative 35° Diamond (KAPR: 93°)



Coolant Thru

PRODUCT # Left hand	PRODUCT # Right hand	Designation	DCON MS	LF	WF	DMIN	KAPR	Insert	Shim	Clamp	Clamp Screw	Lock Pin
912-000-008	912-000-009	MH16 MVUNR/L3-CFT	1.000	1.625	0.875	1.435	93.0	VNMG 332	IVSN-322	CL-20	XNS-47	NL-34L
912-000-033	912-000-034	MH20 MVUNR/L3-CFT	1.250	1.625	1.000	1.705	93.0	VNMG 332	IVSN-322	CL-20	XNS-47	NL-34L
912-000-066	912-000-067	MH24 MVUNR/L3-CFT	1.500	1.625	1.125	2.000	93.0	VNMG 332	IVSN-322	CL-20	XNS-47	NL-34L
912-000-098	912-000-099	MH28 MVUNR/L3-CFT	1.750	1.625	1.250	2.250	93.0	VNMG 332	IVSN-322	CL-20	XNS-47	NL-34L
912-000-144	912-000-145	MH32 MVUNR/L3-CFT	2.000	1.625	1.375	2.500	93.0	VNMG 332	IVSN-322	CL-20	XNS-47	NL-34L
912-000-183	912-000-185	MH40 MVUNR/L3-CFT	2.500	1.625	1.750	3.250	93.0	VNMG 332	IVSN-322	CL-20	XNS-47	NL-34L
912-000-184	912-000-186	MH40 MVUNR/L4-CFT	2.500	1.625	1.750	3.250	93.0	VNMG 432	IVSN-432	CL-22	XNS-48	NL-46

PRODUCT #	Clamp
968-000-016	CL-6
968-000-017	CL-7
968-000-020	CL-9
968-000-010	CL-12
968-000-011	CL-19
968-000-012	CL-20

PACKAGE SIZE OF 1

PRODUCT #	Clamp
968-000-013	CL-21
968-000-014	CL-22
968-000-015	CL-30
968-000-018	CL-84
968-000-019	CL-85

PACKAGE SIZE OF 1

PRODUCT #	Clamp Screw
968-000-176	XNS-36
968-000-177	XNS-47
968-000-178	XNS-48
968-000-179	XNS-510
968-000-180	XNS-58
968-000-181	XNS-59

PACKAGE SIZE OF 5

PRODUCT #	Lock Pin
968-000-097	NL-33
968-000-098	NL-33L
968-000-099	NL-34
968-000-100	NL-34L
968-000-101	NL-44
968-000-102	NL-46
968-000-103	NL-56
968-000-104	NL-58
968-000-105	NL-68
968-000-106	NL-68L

PACKAGE SIZE OF 5

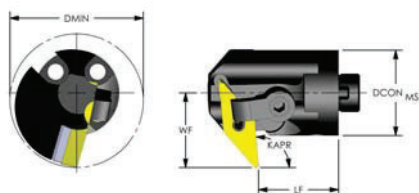

**Negative 35° Diamond (KAPR: 95°)
Back Facing**



Coolant Thru

PRODUCT # Left hand	PRODUCT # Right hand	Designation	DCON MS	LF	WF	DMIN	KAPR	Insert	Shim	Clamp	Clamp Screw	Lock Pin
912-000-010	912-000-011	MH16 MVXNR/L3-CFT	1.000	0.940	0.875	1.435	95.0	VNMG 332	IVSN-322	CL-20	XNS-47	NL-34L
912-000-035	912-000-036	MH20 MVXNR/L3-CFT	1.250	1.000	1.000	1.705	95.0	VNMG 332	IVSN-322	CL-20	XNS-47	NL-34L
912-000-068	912-000-069	MH24 MVXNR/L3-CFT	1.500	1.120	1.125	2.000	95.0	VNMG 332	IVSN-322	CL-20	XNS-47	NL-34L
912-000-100	912-000-101	MH28 MVXNR/L3-CFT	1.750	1.120	1.250	2.250	95.0	VNMG 332	IVSN-322	CL-20	XNS-47	NL-34L
912-000-146	912-000-147	MH32 MVXNR/L3-CFT	2.000	1.120	1.375	2.500	95.0	VNMG 332	IVSN-322	CL-20	XNS-47	NL-34L
912-000-187	912-000-188	MH40 MVXNR/L3-CFT	2.500	1.120	1.750	3.250	95.0	VNMG 332	IVSN-322	CL-20	XNS-47	NL-34L



Threading / Grooving Laydown



Coolant Thru

PRODUCT #	Designation Right hand	DCON MS	LF	WF	DMIN	Insert	Insert Screw	Anvil Screw	Anvil
912-000-002	MH16 LSER3-CFT	1.000	1.625	0.650	1.200	3IR	SA3T	SY3T	YI3
912-000-023	MH20 LSER3-CFT	1.250	1.625	0.770	1.450	3IR	SA3T	SY3T	YI3
912-000-051	MH24 LSER3-CFT	1.500	1.625	0.900	1.650	3IR	SA3T	SY3T	YI3
912-000-085	MH28 LSER3-CFT	1.750	1.625	1.090	2.020	3IR	SA3T	SY3T	YI3
912-000-122	MH32 LSER3-CFT	2.000	1.625	1.281	2.400	3IR	SA3T	SY3T	YI3
912-000-052	MH24 LSER4-CFT	1.500	1.625	0.978	1.782	4IR	SA4T	SY4T	YI4
912-000-084	MH28 LSER4-CFT	1.750	1.625	1.090	2.020	4IR	SA4T	SY4T	YI4
912-000-123	MH32 LSER4-CFT	2.000	1.625	1.281	2.400	4IR	SA4T	SY4T	YI4
912-000-124	MH32 LSER5-CFT	2.000	1.625	1.281	2.400	5IR	SA5T	SY5T	YI5
912-000-165	MH40 LSER5-CFT	2.500	1.625	1.530	2.800	5IR	SA5T	SY5T	YI5

PRODUCT #	Designation Left hand	DCON MS	LF	WF	DMIN	Insert	Insert Screw	Anvil Screw	Anvil
912-000-001	MH16 LSEL3-CFT	1.000	1.625	0.650	1.200	3IL	SA3T	SY3T	YE3
912-000-022	MH20 LSEL3-CFT	1.250	1.625	0.770	1.450	3IL	SA3T	SY3T	YE3
912-000-049	MH24 LSEL3-CFT	1.500	1.625	0.900	1.650	3IL	SA3T	SY3T	YE3
912-000-083	MH28 LSEL3-CFT	1.750	1.625	1.090	2.020	3IL	SA3T	SY3T	YE3
912-000-119	MH32 LSEL3-CFT	2.000	1.625	1.281	2.400	3IL	SA3T	SY3T	YE3
912-000-051	MH24 LSEL4-CFT	1.500	1.625	0.978	1.782	4IL	SA4T	SY4T	YE4
912-000-086	MH28 LSEL4-CFT	1.750	1.625	1.090	2.020	4IL	SA4T	SY4T	YE4
912-000-120	MH32 LSEL4-CFT	2.000	1.625	1.281	2.400	4IL	SA4T	SY4T	YE4
912-000-121	MH32 LSEL5-CFT	2.000	1.625	1.281	2.400	5IL	SA5T	SY5T	YE5
912-000-164	MH40 LSEL5-CFT	2.500	1.625	1.530	2.800	5IL	SA5T	SY5T	YE5

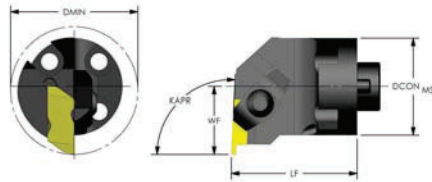

Threading / Grooving Top Notch



Coolant Thru

PRODUCT #	Designation Right Hand	DCON MS	LF	WF	DMIN	Insert	Clamp	Screw
912-000-040	MH20 NER3-CFT	1.250	1.625	0.875	1.750	NG 3L	CM-73	10-32
912-000-073	MH24 NER3-CFT	1.500	1.625	1.000	2.000	NG 3L	CM-73	10-32
912-000-107	MH28 NER3-CFT	1.750	1.625	1.125	2.250	NG 3L	CM-73	10-32
912-000-153	MH32 NER3-CFT	2.000	1.625	1.250	2.410	NG 3L	CM-73	10-32
912-000-108	MH28 NER4-CFT	1.750	1.625	1.250	2.500	NG 4L	CM-73	10-32
912-000-154	MH32 NER4-CFT	2.000	1.625	1.375	2.750	NG 4L	CM-73	10-32
912-000-193	MH40 NER4-CFT	2.500	1.625	1.625	3.250	NG 4L	CM-73	10-32
912-000-109	MH28 NER6-CFT	1.750	1.625	1.250	2.500	NG 6L	CM-121	10-32
912-000-155	MH32 NER6-CFT	2.000	1.625	1.375	2.750	NG 6L	CM-121	10-32
912-000-194	MH40 NER6-CFT	2.500	1.625	1.625	3.250	NG 6L	CM-121	10-32

PRODUCT #	Clamp
968-000-025	CM-72
968-000-026	CM-73
968-000-027	CM-74
968-000-028	CM-75
968-000-021	CM-120
968-000-022	CM-121
968-000-023	CM-146
968-000-024	CM-147

PACKAGE SIZE OF 1

PRODUCT #	Clamp Screw
968-000-005	6-32
968-000-003	10-32
968-000-096	MTS-526

PACKAGE SIZE OF 5

PRODUCT #	Designation Left hand	DCON MS	LF	WF	DMIN	Insert	Clamp	Screw
912-000-039	MH20 NEL3-CFT	1.250	1.625	.875	1.750	NG 3R	CM-72	10-32
912-000-072	MH24 NEL3-CFT	1.500	1.625	1.000	2.000	NG 3R	CM-72	10-32
912-000-104	MH28 NEL3-CFT	1.750	1.625	1.125	2.250	NG 3R	CM-72	10-32
912-000-150	MH32 NEL3-CFT	2.000	1.625	1.250	2.410	NG 3R	CM-72	10-32
912-000-105	MH28 NEL4-CFT	1.750	1.625	1.250	2.500	NG 4R	CM-72	10-32
912-000-151	MH32 NEL4-CFT	2.000	1.625	1.375	2.750	NG 4R	CM-72	10-32
912-000-191	MH40 NEL4-CFT	2.500	1.625	1.625	3.250	NG 4R	CM-72	10-32
912-000-106	MH28 NEL6-CFT	1.750	1.625	1.250	2.500	NG 6R	CM-120	10-32
912-000-152	MH32 NEL6-CFT	2.000	1.625	1.375	2.750	NG 6R	CM-120	10-32
912-000-192	MH40 NEL6-CFT	2.500	1.625	1.625	3.250	NG 6R	CM-120	10-32

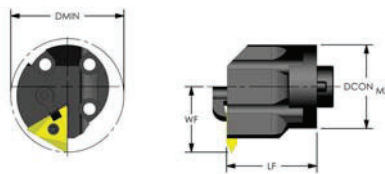

Threading / Grooving On Edge



Coolant Thru

PRODUCT # Left hand	PRODUCT # Right hand	Designation	DCON MS	LF	WF	DMIN	Insert	Clamp	Screw	Lock Pin
912-000-063	912-000-064	MH24 MTHOR/L4-CFT	1.500	1.625	1.173	2.625	TNMA 43	CL-7	XNS-36	NL-44
912-000-095	912-000-096	MH28 MTHOR/L4-CFT	1.750	1.625	1.298	2.750	TNMA 43	CL-7	XNS-36	NL-44
912-000-141	912-000-142	MH32 MTHOR/L4-CFT	2.000	1.625	1.423	2.875	TNMA 43	CL-7	XNS-36	NL-44

PRODUCT #	Clamp Screw
968-000-176	XNS-36
968-000-177	XNS-47
968-000-178	XNS-48
968-000-179	XNS-510
968-000-180	XNS-58
968-000-181	XNS-59

PACKAGE SIZE OF 5

PRODUCT #	Lock Pin
968-000-097	NL-33
968-000-098	NL-33L
968-000-099	NL-34
968-000-100	NL-34L
968-000-101	NL-44
968-000-102	NL-46
968-000-103	NL-56
968-000-104	NL-58
968-000-105	NL-68
968-000-106	NL-68L

PACKAGE SIZE OF 5

PRODUCT #	Clamp
968-000-016	CL-6
968-000-017	CL-7
968-000-020	CL-9
968-000-010	CL-12
968-000-011	CL-19
968-000-012	CL-20

PACKAGE SIZE OF 1



STEEL SHANK

4:1 Ratio
Coolant Thru

PRODUCT #	Designation	DCON MS	DCON WS	LU	LF	Head Bolts
911-000-009	AS1000-12	1.000	25mm	N/A	12.000	8-32
911-000-010	AS1250-14	1.250	32mm	N/A	14.000	10-24
911-000-011	AS1500-14	1.500	32mm	0.250	14.000	10-24
911-000-012	AS1750-16	1.750	40mm	0.250	16.000	1/4-20
911-000-013	AS2000-20	2.000	40mm	0.250	20.000	1/4-20
911-000-014	AS2500-12	2.500	40mm	0.250	12.000	1/4-20
911-000-015	AS2500-24	2.500	40mm	0.250	24.000	1/4-20

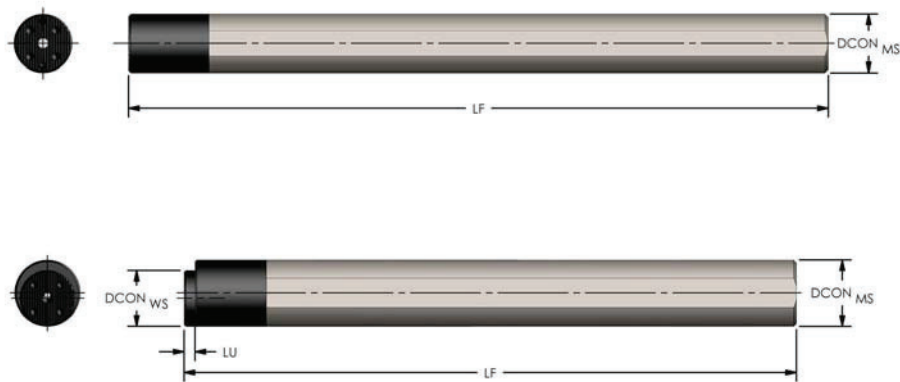

CARBIDE SHANK

8:1 Ratio
Coolant Thru

PRODUCT #	Designation	DCON MS	DCON WS	LU	LF	Head Bolts
911-000-021	ES1000-12	1.000	25mm	N/A	12.000	8-32
911-000-022	ES1250-14	1.250	32mm	N/A	14.000	10-24
911-000-023	ES1500-14	1.500	32mm	0.250	14.000	10-24
911-000-024	ES1750-16	1.750	40mm	0.250	16.000	1/4-20
911-000-025	ES2000-20	2.000	40mm	0.250	20.000	1/4-20

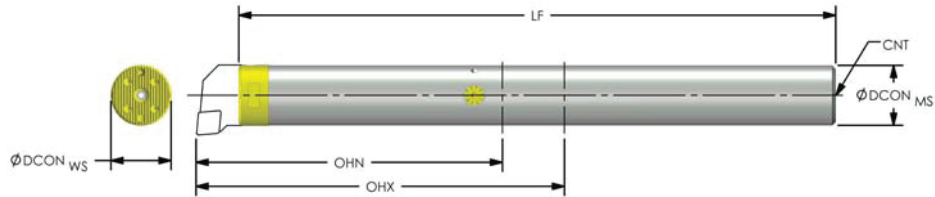

MODULAR STEALTH BARS

Coolant Thru

5:1 Ratio

PRODUCT #	Designation	DCON MS	DCON WS	LF	OHN	OHX	Head Bolts	CNT
910-000-064	SCFT B1500-9	1.500	32mm	9.000	7.000	7.500	10-24 HB	1/8-27 NPT
910-000-069	SCFT B2000-12	2.000	40mm	12.000	7.500	10.000	1/4-20 HB	1/8-27 NPT
910-000-074	SCFT B2500-16	2.500	40mm	16.000	8.000	12.500	1/4-20 HB	1/8-27 NPT

7:1 Ratio

910-000-052	SCFT B1000-10	1.000	25mm	10.000	5.000	7.000	8-32 HB	1/8-27 NPT
910-000-056	SCFT B1250-12	1.250	32mm	12.000	6.250	8.750	10-24 HB	1/8-27 NPT
910-000-060	SCFT B1500-15	1.500	32mm	15.000	7.500	10.500	10-24 HB	1/8-27 NPT
910-000-065	SCFT B1750-18	1.750	40mm	18.000	8.750	12.250	1/4-20 HB	1/8-27 NPT
910-000-070	SCFT B2000-20	2.000	40mm	20.000	10.000	14.000	1/4-20 HB	1/8-27 NPT
910-000-075	SCFT B2500-27	2.500	40mm	27.000	12.500	17.500	1/4-20 HB	1/4-18 NPT

10:1 Ratio

910-000-053	SCFT B1000-14	1.000	25mm	14.000	7.000	10.000	8-32 HB	1/8-27 NPT
910-000-057	SCFT B1250-16	1.250	32mm	16.000	8.750	12.500	10-24 HB	1/8-27 NPT
910-000-061	SCFT B1500-19	1.500	32mm	19.000	10.500	15.000	10-24 HB	1/8-27 NPT
910-000-066	SCFT B1750-23	1.750	40mm	23.000	12.250	17.500	1/4-20 HB	1/8-27 NPT
910-000-071	SCFT B2000-26	2.000	40mm	26.000	14.000	20.000	1/4-20 HB	1/8-27 NPT
910-000-076	SCFT B2500-33	2.500	40mm	33.000	17.500	25.000	1/4-20 HB	1/4-18 NPT

12:1 Ratio

910-000-054	SCFT B1000-16	1.000	25mm	16.000	10.875	12.000	8-32 HB	N/A
910-000-058	SCFT B1250-18	1.250	32mm	18.000	13.785	15.000	10-24 HB	N/A
910-000-062	SCFT B1500-22	1.500	32mm	22.000	16.375	18.000	10-24 HB	N/A
910-000-067	SCFT B1750-25	1.750	40mm	25.000	18.060	21.000	1/4-20 HB	N/A
910-000-072	SCFT B2000-29	2.000	40mm	29.000	19.375	24.000	1/4-20 HB	N/A

14:1 Ratio

910-000-055	SCFT B1000-18	1.000	25mm	18.000	10.875	12.000	8-32 HB	N/A
910-000-059	SCFT B1250-21	1.250	32mm	21.000	13.875	15.000	10-24 HB	N/A
910-000-063	SCFT B1500-25	1.500	32mm	25.000	16.375	18.000	10-24 HB	N/A
910-000-068	SCFT B1750-29	1.750	40mm	29.000	18.060	21.000	1/4-20 HB	N/A
910-000-073	SCFT B2000-33	2.000	40mm	33.000	19.375	24.000	1/4-20 HB	N/A

PRODUCT #	Head Bolts
968-000-006	8-32 HB
968-000-002	10-24 HB
968-000-001	1/4-20 HB
968-000-004	5/16-18 HB

PACKAGE SIZE OF 1

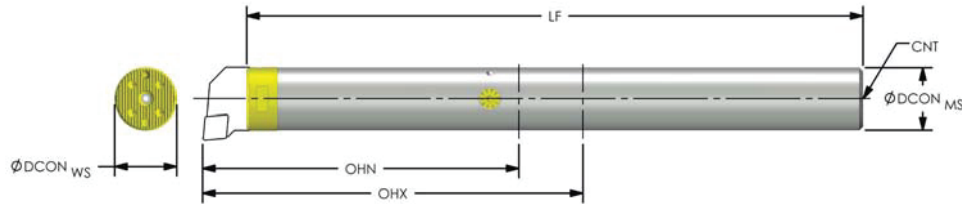

7:1 Ratio

MODULAR STEALTH BARS

Coolant Thru

PRODUCT #	Designation	DCON MS	DCON WS	LF	OHN	OHX	Head Bolts	CNT
910-000-077	SCFT B25MM-250	25mm	25mm	250mm	127mm	175mm	8-32 HB	1/8-27 NPT
910-000-079	SCFT B32MM-320	32mm	32mm	320mm	159mm	224mm	10-24 HB	1/8-27 NPT
910-000-083	SCFT B40MM-400	40mm	40mm	400mm	190mm	280mm	1/4-20 HB	1/8-27 NPT
910-000-087	SCFT B50MM-500	50mm	40mm	500mm	254mm	350mm	1/4-20 HB	1/8-27 NPT
910-000-091	SCFT B60MM-600	60mm	40mm	600mm	320mm	420mm	1/4-20 HB	1/8-27 NPT

10:1 Ratio

910-000-078	SCFT B25MM-325	25mm	25mm	325mm	178mm	250mm	8-32 HB	1/8-27 NPT
910-000-080	SCFT B32MM-416	32mm	32mm	416mm	223mm	320mm	10-24 HB	1/8-27 NPT
910-000-084	SCFT B40MM-520	40mm	40mm	520mm	266mm	400mm	1/4-20 HB	1/8-27 NPT
910-000-088	SCFT B50MM-650	50mm	40mm	650mm	356mm	500mm	1/4-20 HB	1/8-27 NPT
910-000-092	SCFT B60MM-780	60mm	40mm	780mm	445mm	600mm	1/4-20 HB	1/8-27 NPT

12:1 Ratio

910-000-081	SCFT B32MM-480	32mm	32mm	480mm	352mm	384mm	10-24 HB	N/A
910-000-085	SCFT B40MM-600	40mm	40mm	600mm	416mm	480mm	1/4-20 HB	N/A
910-000-089	SCFT B50MM-750	50mm	40mm	750mm	492mm	600mm	1/4-20 HB	N/A

14:1 Ratio

910-000-082	SCFT B32MM-544	32mm	32mm	544mm	352mm	448mm	10-24 HB	N/A
910-000-086	SCFT B40MM-680	40mm	40mm	680mm	416mm	560mm	1/4-20 HB	N/A
910-000-090	SCFT B50MM-850	50mm	40mm	850mm	492mm	788mm	1/4-20 HB	N/A

PRODUCT #	Head Bolts
968-000-006	8-32 HB
968-000-002	10-24 HB
968-000-001	1/4-20 HB
968-000-004	5/16-18 HB

PACKAGE SIZE OF 1

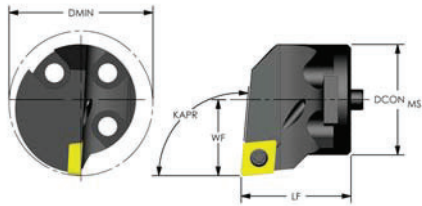

Positive 80° Diamond (KAPR:95°)



Coolant Thru

PRODUCT # Left hand	PRODUCT # Right hand	Designation	DCON MS	Coupling Size	LF	WF	DMIN	KAPR	Insert	Insert Screw	Key
912-000-205	912-000-206	SH16 SCLCR/L3	0.984	25mm	0.787	0.669	1.260	95.0	CCMT 32.52	MTS-35	T-15
912-000-233	912-000-234	SH20 SCLCR/L3	1.260	32mm	1.260	0.866	1.575	95.0	CCMT 32.52	MTS-35	T-15
912-000-263	912-000-264	SH24 SCLCR/L4	1.575	40mm	1.496	1.063	1.968	95.0	CCMT 432	MTS-4	T-20

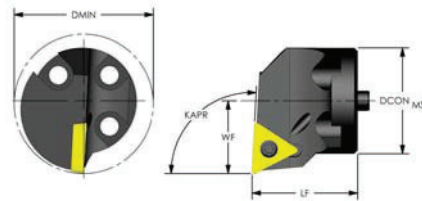

Positive Triangle (KAPR:93°)



Coolant Thru

PRODUCT # Left hand	PRODUCT # Right hand	Designation	DCON MS	Coupling Size	LF	WF	DMIN	KAPR	Insert	Insert Screw	Key
912-000-215	912-000-216	SH16 STUCR/L2	0.984	25mm	0.787	0.669	1.260	93.0	TCMT 21.51	MTS-255	T-7
912-000-243	912-000-244	SH20 STUCR/L3	1.260	32mm	1.260	0.866	1.575	93.0	TCMT 32.52	MTS-35	T-15
912-000-273	912-000-274	SH24 STUCR/L3	1.575	40mm	1.496	1.063	1.968	93.0	TCMT 32.52	MTS-35	T-15

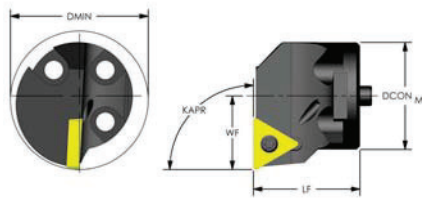

Positive Triangle (KAPR:90°)



Coolant Thru

PRODUCT # Left hand	PRODUCT # Right hand	Designation	DCON MS	Coupling Size	LF	WF	DMIN	KAPR	Insert	Insert Screw	Key
912-000-213	912-000-214	SH16 STFCR/L2	0.984	25mm	0.787	0.669	1.260	90.0	TCMT 21.51	MTS-255	T-7
912-000-241	912-000-242	SH20 STFCR/L3	1.260	32mm	1.260	0.866	1.575	90.0	TCMT 32.52	MTS-35	T-15
912-000-271	912-000-272	SH24 STFCR/L3	1.575	40mm	1.496	1.063	1.968	90.0	TCMT 32.52	MTS-35	T-15

PRODUCT #	Insert Screws
968-000-086	MTS-183
968-000-087	MTS-184
968-000-088	MTS-2
968-000-091	MTS-224
968-000-092	MTS-255
968-000-094	MTS-35
968-000-090	MTS-2.5L
968-000-052	ETS 4-40

PACKAGE SIZE OF 5

PRODUCT #	Key
968-000-156	T-6
968-000-158	T-7
968-000-149	T-10
968-000-151	T-15
968-000-153	T-20

PACKAGE SIZE OF 5

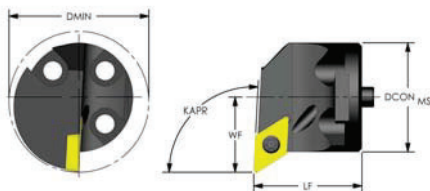

Positive 55° Diamond (KAPR: 93°) Profiling



Coolant Thru

PRODUCT # Left hand	PRODUCT # Right hand	Designation	DCON MS	Coupling Size	LF	WF	DMIN	KAPR	Insert	Insert Screw	Key
912-000-209	912-000-210	SH16 SDUCR/L3	0.984	25mm	0.787	0.669	1.260	93.0	DCMT 32.52	MTS-35	T-15
912-000-237	912-000-238	SH20 SDUCR/L3	1.260	32mm	1.260	0.866	1.575	93.0	DCMT 32.52	MTS-35	T-15
912-000-267	912-000-268	SH24 SDUCR/L3	1.575	40mm	1.260	1.063	1.968	93.0	DCMT 32.52	MTS-35	T-15

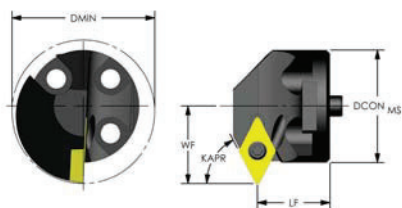

Positive 55° Diamond (KAPR: 62.5°) Profiling



Coolant Thru

PRODUCT # Left hand	PRODUCT # Right hand	Designation	DCON MS	Coupling Size	LF	WF	DMIN	KAPR	Insert	Insert Screw	Key
912-000-207	912-000-208	SH16 SDNCR/L2	0.984	25mm	0.591	0.709	1.299	62.5	DCMT 21.51	MTS-255	T-7
912-000-235	912-000-236	SH20 SDNCR/L3	1.260	32mm	0.787	0.866	1.575	62.5	DCMT 32.52	MTS-35	T-15
912-000-265	912-000-266	SH24 SDNCR/L3	1.575	40mm	0.787	1.063	1.968	62.5	DCMT 32.52	MTS-35	T-15

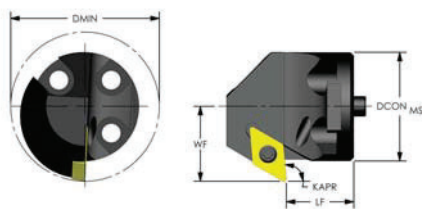

Positive 55° Diamond (KAPR: 95°) Back Facing



Coolant Thru

PRODUCT # Left hand	PRODUCT # Right hand	Designation	DCON MS	Coupling Size	LF	WF	DMIN	KAPR	Insert	Insert Screw	Key
912-000-211	912-000-212	SH16 SDXCR/L2	0.984	25mm	0.591	0.709	1.299	95.0	DCMT 21.51	MTS-255	T-7
912-000-239	912-000-240	SH20 SDXCR/L3	1.260	32mm	0.787	0.866	1.575	95.0	DCMT 32.52	MTS-35	T-15
912-000-269	912-000-270	SH24 SDXCR/L3	1.575	40mm	0.787	1.063	1.968	95.0	DCMT 32.52	MTS-35	T-15

PRODUCT #	Insert Screws
968-000-086	MTS-183
968-000-087	MTS-184
968-000-088	MTS-2
968-000-091	MTS-224
968-000-092	MTS-255
968-000-094	MTS-35
968-000-090	MTS-2.5L
968-000-052	ETS 4-40

PACKAGE SIZE OF 5

PRODUCT #	Key
968-000-156	T-6
968-000-158	T-7
968-000-149	T-10
968-000-151	T-15
968-000-153	T-20

PACKAGE SIZE OF 5

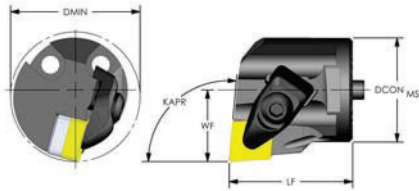

PULLBACK Clamp Negative 80° Diamond (KAPR 95° Lead)

Coolant Thru

PRODUCT # Left Hand	PRODUCT # Right Hand	Designation	DCON MS	Coupling Size	LF	WF	DMIN	KAPR	Insert	Shim Seat	Shim Screw	Clamp Assy.
912-000-217	912-000-218	SH20 DCLNR/L4	1.260	32mm	1.496	0.866	1.575	95.0	CNMG 432	ICSN-433	PB4-SS	PB4-CA
912-000-245	912-000-246	SH24 DCLNR/L4	1.575	40mm	1.496	1.063	1.968	95.0	CNMG 432	ICSN-433	PB4-SS	PB4-CA

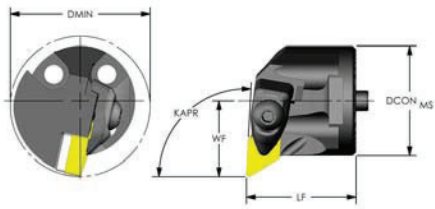

PULLBACK Clamp Negative 55° Diamond (KAPR: 93°)

Coolant Thru

PRODUCT # Left Hand	PRODUCT # Right Hand	Designation	DCON MS	Coupling Size	LF	WF	DMIN	KAPR	Insert	Shim Seat	Shim Screw	Clamp Assy.
912-000-219	912-000-220	SH20 DDUNR/L3	1.260	32mm	1.260	0.866	1.575	93.0	DNMG 332	IDSN-322	PB3-SS	PB3-CA
912-000-247	912-000-248	SH24 DDUNR/L4	1.575	40mm	1.260	1.063	1.968	93.0	DNMG 432	IDSN-433	PB4-SS	PB4-CA

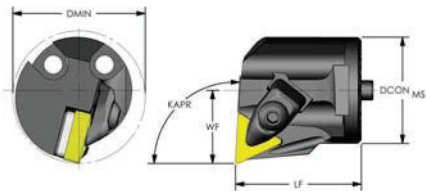

PULLBACK Clamp Negative Triangle (KAPR: 93°)

Coolant Thru

PRODUCT # Left Hand	PRODUCT # Right Hand	Designation	DCON MS	Coupling Size	LF	WF	DMIN	Insert	Shim Seat	Shim Screw	Clamp Assy.
912-000-223	912-000-224	SH20 DTUNR/L3	1.260	32mm	1.496	0.866	1.575	TNMG 332	ITSN-323	PB3-SS	PB3-CA
912-000-251	912-000-252	SH24 DTUNR/L3	1.575	40mm	1.496	1.063	1.968	TNMG 332	ITSN-323	PB3-SS	PB3-CA

PRODUCT #	Shim Seat
968-000-053	ICSN-433
968-000-054	ICSN-533
968-000-055	ICSN-633
968-000-063	ISSN-432
968-000-064	ISSN-433
968-000-065	ISSN-533
968-000-066	ISSN-633
968-000-056	IDSN-322
968-000-057	IDSN-433
968-000-058	IDSN-533
968-000-067	ITSN-323
968-000-068	ITSN-433

PACKAGE SIZE OF 10

PRODUCT #	Shim Seat
968-000-069	ITSN-533
968-000-070	ITSN-636
968-000-071	IVSN-322
968-000-072	IVSN-432
968-000-073	IVSN-433
968-000-074	IWSN-322
968-000-075	IWSN-433
968-000-059	IRSN-32
968-000-060	IRSN-43
968-000-061	IRSN-53
968-000-062	IRSN-63

PACKAGE SIZE OF 10

PRODUCT #	Shim Screw
968-000-109	PB3-SS
968-000-111	PB4-SS

PACKAGE SIZE OF 5

PRODUCT #	Clamp Assy.
968-000-107	PB3-CA
968-000-110	PB4-CA

PACKAGE SIZE OF 1

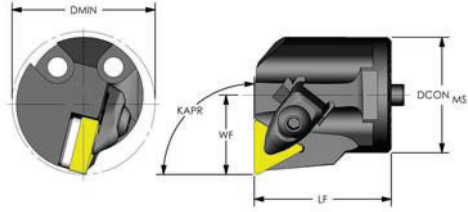

PULLBACK Clamp Negative Triangle (KAPR: 90°)



Coolant Thru

PRODUCT # Left Hand	PRODUCT # Right Hand	Designation	DCON MS	Coupling Size	LF	WF	DMIN	KAPR	Insert	Shim Seat	Shim Screw	Clamp Assy.
912-000-221	912-000-222	SH20 DTFNR/L3	1.260	32mm	1.496	0.866	1.575	90.0	TNMG 332	ITSN-323	PB3-SS	PB3-CA
912-000-249	912-000-250	SH24 DTFNR/L3	1.575	40mm	1.496	1.063	1.968	90.0	TNMG 332	ITSN-323	PB3-SS	PB3-CA

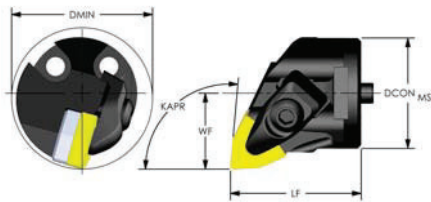

PULLBACK Clamp Negative Trigon (KAPR: 95°)



Coolant Thru

PRODUCT # Left Hand	PRODUCT # Right Hand	Designation	DCON MS	Coupling Size	LF	WF	DMIN	KAPR	Insert	Shim Seat	Shim Screw	Clamp Assy.
912-000-225	912-000-226	SH20 DWLNR/L4	1.260	32mm	1.496	0.866	1.575	95.0	WNMG 432	IWSN-433	PB4-SS	PB4-CA
912-000-253	912-000-254	SH24 DWLNR/L4	1.575	40mm	1.496	1.063	1.968	95.0	WNMG 432	IWSN-433	PB4-SS	PB4-CA

PRODUCT #	Shim Seat
968-000-053	ICSN-433
968-000-054	ICSN-533
968-000-055	ICSN-633
968-000-063	ISSN-432
968-000-064	ISSN-433
968-000-065	ISSN-533
968-000-066	ISSN-633
968-000-056	IDSN-322
968-000-057	IDSN-433
968-000-058	IDSN-533
968-000-067	ITSN-323
968-000-068	ITSN-433

PACKAGE SIZE OF 10

PRODUCT #	Shim Seat
968-000-069	ITSN-533
968-000-070	ITSN-636
968-000-071	IVSN-322
968-000-072	IVSN-432
968-000-073	IVSN-433
968-000-074	IWSN-322
968-000-075	IWSN-433
968-000-059	IRSN-32
968-000-060	IRSN-43
968-000-061	IRSN-53
968-000-062	IRSN-63

PACKAGE SIZE OF 10

PRODUCT #	Shim Screw
968-000-109	PB3-SS
968-000-111	PB4-SS

PACKAGE SIZE OF 5

PRODUCT #	Clamp Assy.
968-000-107	PB3-CA
968-000-110	PB4-CA

PACKAGE SIZE OF 1

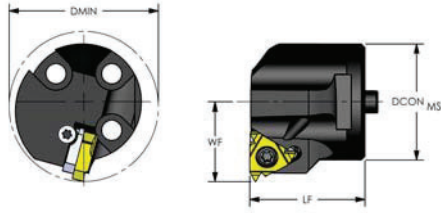

Threading / Grooving Laydown



Coolant Thru

PRODUCT #	Designation Right Hand	DCON MS	Coupling Size	LF	WF	DMIN	Insert	Insert Screw	Anvil Screw	Anvil
912-000-204	SH16 LSER3	.984	25mm	0.984	0.669	1.260	3IR	SA3T	SY3T	YI3
912-000-229	SH20 LSER3	1.260	32mm	1.260	0.866	1.575	3IR	SA3T	SY3T	YI3
912-000-257	SH24 LSER3	1.575	40mm	1.496	1.063	1.968	3IR	SA3T	SY3T	YI3
912-000-230	SH20 LSER4	1.260	32mm	1.260	0.866	1.575	4IR	SA4T	SY4T	YI4
912-000-258	SH24 LSER4	1.575	40mm	1.496	1.063	1.968	4IR	SA4T	SY4T	YI4

PRODUCT #	Designation Left Hand	DCON MS	Coupling Size	LF	WF	DMIN	Insert	Insert Screw	Anvil Screw	Anvil
912-000-203	SH16 LSEL3	.984	25mm	0.984	0.669	1.260	3IL	SA3T	SY3T	YE3
912-000-227	SH20 LSEL3	1.260	32mm	1.260	0.866	1.575	3IL	SA3T	SY3T	YE3
912-000-255	SH24 LSEL3	1.575	40mm	1.496	1.063	1.968	3IL	SA3T	SY3T	YE3
912-000-228	SH20 LSEL4	1.260	32mm	1.260	0.866	1.575	4IL	SA4T	SY4T	YE4
912-000-256	SH24 LSEL4	1.575	40mm	1.496	1.063	1.968	4IL	SA4T	SY4T	YE4

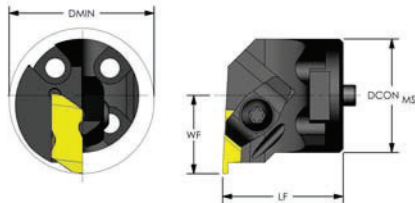

Threading / Grooving Top Notch



Coolant Thru

PRODUCT #	Designation Right Hand	DCON MS	Coupling Size	LF	WF	DMIN	Insert	Clamp	Screw
912-000-232	SH20 NER3	1.260	32mm	1.340	0.866	1.730	NG 3L	CM-73	10-32
912-000-261	SH24 NER3	1.575	40mm	1.575	1.102	2.210	NG 3L	CM-73	10-32
912-000-262	SH24 NER4	1.575	40mm	1.575	1.102	2.210	NG 4L	CM-73	10-32

PRODUCT #	Designation Left Hand	DCON MS	Coupling Size	LF	WF	DMIN	Insert	Clamp	Screw
912-000-231	SH20 NEL3	1.260	32mm	1.340	0.866	1.730	NG 3R	CM-72	10-32
912-000-259	SH24 NEL3	1.575	40mm	1.575	1.102	2.210	NG 3R	CM-72	10-32
912-000-260	SH24 NEL4	1.575	40mm	1.575	1.102	2.210	NG 4R	CM-72	10-32

PRODUCT #	Clamp
968-000-016	CL-6
968-000-017	CL-7
968-000-020	CL-9
968-000-010	CL-12
968-000-011	CL-19
968-000-012	CL-20

PACKAGE SIZE OF 1

PRODUCT #	Clamp
968-000-013	CL-21
968-000-014	CL-22
968-000-015	CL-30
968-000-018	CL-84
968-000-019	CL-85

PACKAGE SIZE OF 1

PRODUCT #	Anvil
968-000-185	YI3
968-000-182	YE3
968-000-187	YI4
968-000-186	YI3M-1.5N
968-000-183	YE4
968-000-188	YI5
968-000-184	YE5

PACKAGE SIZE OF 1

PRODUCT #	Anvil Screw
968-000-146	SY3T
968-000-147	SY4T
968-000-148	SY5T

PACKAGE SIZE OF 5

PRODUCT #	Insert Screw
968-000-124	SA3T
968-000-125	SA4T
968-000-126	SA5T

PACKAGE SIZE OF 5

Choosing the largest possible bar size with the shortest overhang will provide rigidity to minimize vibrations.

Make sure to allow clearance for chips.

5:1 Stealth bars are recommended for grooving and threading where forces are higher than in turning.

Proper clamping of the bar is crucial to performance.
(set screws should not come in contact with the bar)

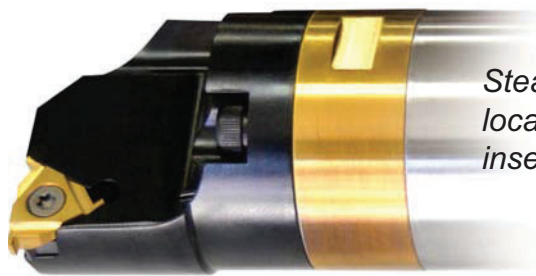

Stealth bars Ø1.0," and larger have a flat located on the gold ring to indicate the insert on the centerline.

Overhang is measured from cutting edge to face of boring bar holder.
Bars should not be extended past the specified diameter to length ratio.
The Bars can be modified to reduce overall length .

To compensate for bar deflection due to extended overhangs, rotating the insert above center line will help.

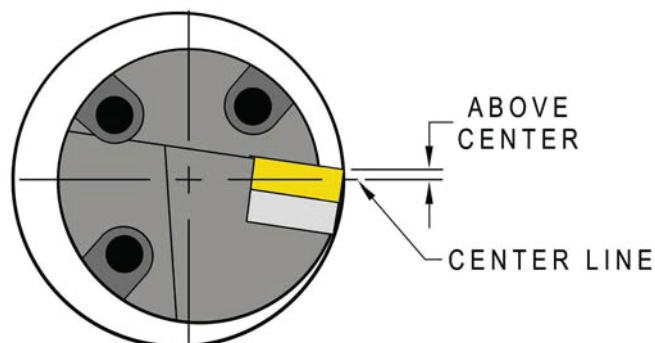

Split Collar System

To assure the best rigidity of the boring bar, the Split Collar System is the best holder. This process is achieved by locking the bar 360° on the diameter.



Split Bushing System

If set screws are to be used, a split bushing must be placed on the bar before placing in the machine. Set screws will contact the bushing and tighten around the bar.



Set Screw Lock System

Do not lock in the boring bar with set screws. This creates very poor rigidity when there is one point of contact.

For Bars $\varnothing.75''$ and Smaller

1. Make a test cut with the bar.
2. Insert supplied T-handle wrench into the end of the bar.
3. If the pitch of the chatter was high, tighten the adjust screw 1/16 turn.(+)
4. If the pitch of the chatter was low, loosen the adjust screw 1/16turn.(-)
5. Make a test cut with the bar.
6. Repeat step 3 until the desired performance is achieved.

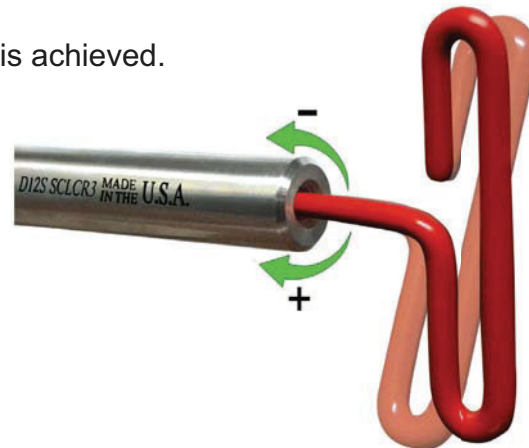

For Bars $\varnothing 1.0''$ and Above

1. Make a test cut with the bar.
2. Loosen lock screw two complete turns in the negative direction.
3. If the pitch of the chatter was high, tighten the adjust screw 1/2 digit.(+)
4. If the pitch of the chatter was low, loosen the adjust screw 1/2 digit.(-)
5. Make a test cut with the bar.
6. Repeat step 3 until the desired performance is achieved.
7. Tighten lock screw. DO NOT over tighten lock screw.



HANGOUT SPECS

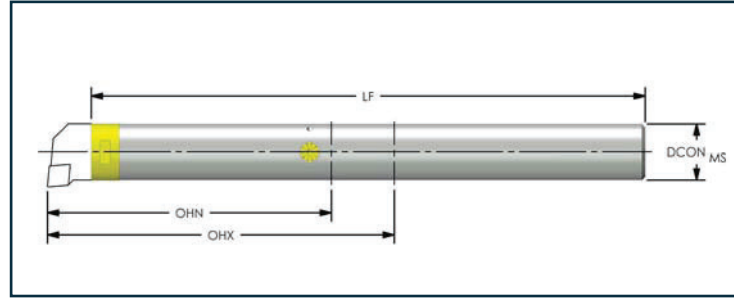

5:1 Ratio

DCONms	OHN	OHX	LF	Weight (LBS)
1.000	5.750	7.50	9.00	4.5
2.000	6.375	10.00	12.00	10.7
2.500	6.750	12.50	16.00	22.8
1.000	5.000	7.00	10.00	2.2
1.250	5.000	8.75	12.00	4.1
1.500	5.750	10.50	15.00	7.5
1.750	6.000	12.25	18.00	11.3
2.000	6.375	14.00	20.00	18.0
2.500	6.750	17.50	27.00	42.0
3.000	12.500	21.00	31.00	63.0
1.000	6.000	10.00	14.00	3.1
1.250	6.750	12.50	16.00	5.7
1.500	9.000	15.00	19.00	11.0
1.750	10.625	17.50	23.00	17.0
2.000	12.375	20.00	26.00	25.0
2.500	15.875	25.00	33.00	42.0
3.000	19.375	30.00	40.00	88.0
4.000	26.375	40.00	50.00	182.0

7:1 Ratio

10:1 Ratio

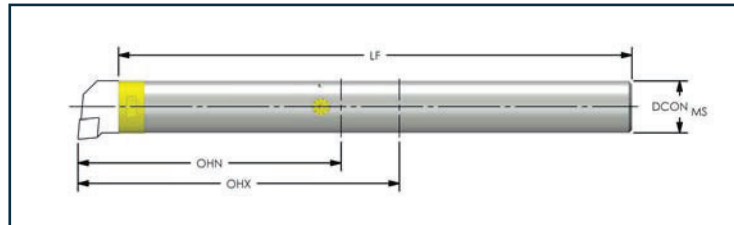

HANGOUT SPECS

CARBIDE REINFORCED

12:1 Ratio

DCONms	OHN	OHX	LF	Weight (LBS)
1.000	9.250	12.00	16.00	5.9
1.250	12.160	15.00	18.00	9.0
1.500	14.750	18.00	22.00	16.4
1.750	16.435	21.00	25.00	25.4
2.000	17.750	24.00	29.00	37.7
1.000	9.250	14.00	18.00	6.9
1.250	12.160	17.50	22.00	10.9
1.500	14.750	21.00	25.00	18.6
1.750	16.435	24.50	29.00	31.0
2.000	17.750	28.00	33.00	44.2